

Received September 4, 2019, accepted September 17, 2019, date of publication September 19, 2019, date of current version October 1, 2019.

Digital Object Identifier 10.1109/ACCESS.2019.2942562

# A Ku-Band Microwave Wireless Energy Transmission System Based on Rectifier Diode

BIAO HU<sup>1</sup>, YIHONG ZHOU<sup>1</sup>, HAO LI<sup>1</sup>, HAIYANG WANG<sup>1</sup>, TIANMING LI<sup>1</sup>, MOHAMED HELAOUI<sup>2</sup>, AND FADHEL M. GHANNOUCHI<sup>2</sup>, (Fellow, IEEE)

<sup>1</sup>School of Electronic Science and Engineering, University of Electronic Science and Technology of China, Chengdu 610054, China

<sup>2</sup>Department of Electrical and Computer Engineering, University of Calgary, Calgary, AB T2N1N4, Canada

Corresponding author: Biao Hu (hubiao@uestc.edu.cn)

This work was supported in part by the National Natural Science Foundation of China under Grant 61601384 and Grant 61671132, and in part by the Project of Sichuan Science and Technology Program in China under Grant M112017GZ0444.

**ABSTRACT** This paper demonstrates a Ku-band medium and long distance microwave wireless energy transmission system based on the rectifier diode. The transmitting compact Cassegrain antenna with an aperture of 1.5m forms a more centralized and uniform  $2m \times 2m$  field zone, which has more than 80% transmission efficiency. According to the distribution of receiving field, the multiple ways synthesizers connected to rectangular patch arrays are designed. And the results predict that the receiving efficiency of the antenna is directly related to the performance of the system, which reaches 50%, not including the possible insert loss. Besides, the Ku-band rectifying circuit is optimized and measured, and the comparing results show that the practical rectifier diode can obtain more than 40% conversion efficiency at the operating frequency of 12.75GHz. Finally, the microwave wireless energy transmission system is designed, and it finally obtains 4% DC-DC conversion efficiency at a distance of 60m, which is likely to be used in unmanned aerial vehicle hovering charging system, robot charging while working, isolated island wireless power supplying and wireless charging of various sensors.

**INDEX TERMS** Wireless energy transmission, Cassegrain antenna, array antenna, rectenna, rectifier diode.

## I. INTRODUCTION

Medium and long distance microwave wireless power transferring and energy harvesting solutions have attracted more and more attention to providing autonomy to a wide variety of sensors and devices, such as unmanned aerial vehicle hovering charging, isolated island energy supply, space solar power station and so on [1], [2]. Microwave is generated and captured by antennas and transformed into DC power by rectifying structures, whose use is more adapted in the case of medium and long distance microwave wireless transmission. The above rectifiers can be done using two different approaches. The first is based on the high-efficiency beam-wave interaction in the cyclotron wave rectifier, which is a more extensive power energy transmission system with many sophisticated ancillary facilities [3]. The second method adopts rectifier diode with small single-transistor power, through power synthesis which can offer the advantage of

allowing medium to long distance power transfer with relatively compact emitter and receiver sizes [4], [5].

Based on the rectifier diode, the France National Scientific Research Center has built the world's first practical microwave wireless transmission system, and successfully achieved the experimental verification of point to point radio power transmission. Although its transmission distance exceeded 100 meters, the project was last interrupted due to the low transmission efficiency below 1% and high cost [6], [7]. Researchers at the Japanese Mitsubishi successfully lit the LED light on the receiving device 500 meters away in microwave form, which is the longest transmission distance and the most extensive transmission power microwave wireless energy transmission experiment. However, because the antennas used in the above research institutes are huge and the overall transmission efficiency is low, they are only a kind of theoretical validation experiments [8], [9]. In recent years, the University of Electronic Science and Technology of China has conducted studies on microwave wireless energy transmission, particularly the design and exploration of the high-efficiency rectifier diode

The associate editor coordinating the review of this manuscript and approving it for publication was Ahmed F. Zobaa .

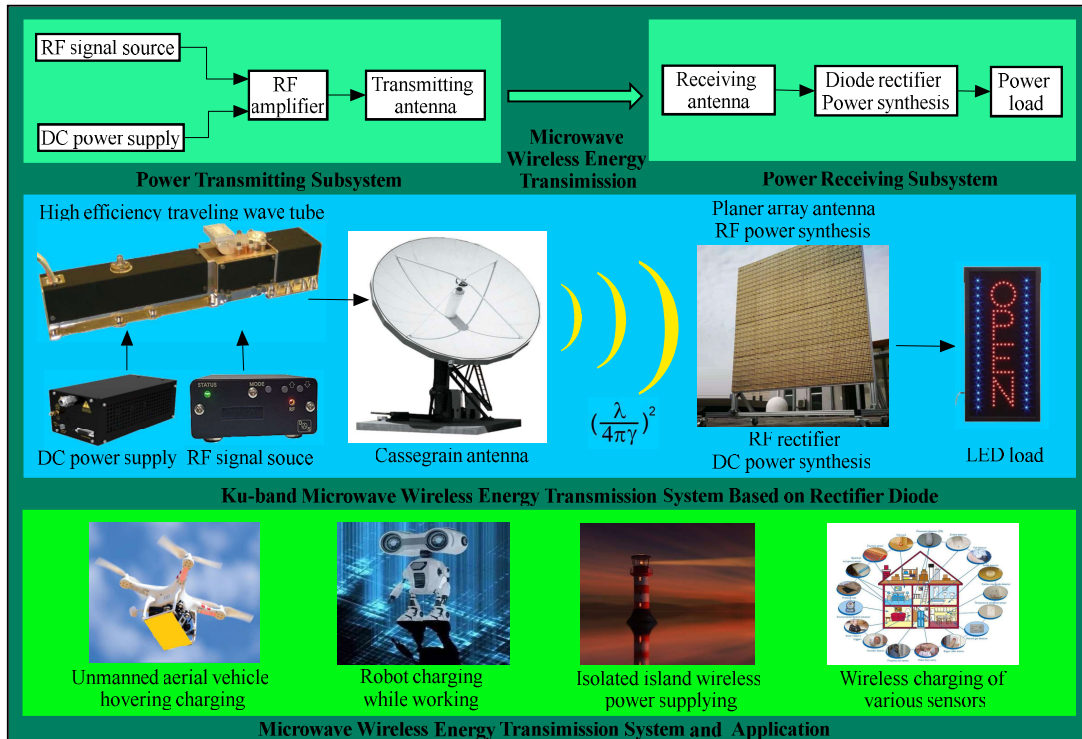

FIGURE 1. Functional block diagram and application of medium to long distance microwave wireless energy transmission system.

and the novel transmitting and receiving antenna. The objective of the paper is to present a Ku-band medium to long distance wireless energy transmission system based on rectifier diode, which is likely to be used in unmanned aerial vehicle hovering charging system [10], robot charging while working [11], isolated island wireless power supplying [12] and wireless charging of various sensors [13], [14].

## II. DESIGN OF MICROWAVE WIRELESS ENERGY TRANSMISSION SYSTEM

The composition of the microwave wireless energy transmission system is showing in Fig. 1, which includes the power transmitting subsystem and the power receiving subsystem. In order to miniaturize the microwave wireless energy transmission and make full use of the practical high-efficiency microwave generator, the operating frequency chooses at 12.75GHz. In the power transmitting subsystem, the microwave generator adopts the traveling wave tube, which is compact and high efficiency, and it can output 150W microwave power with 60% conversion efficiency at the system operating frequency. Then the output power is transmitted by a Cassegrain antenna. Due to the reflection of the main plane and secondary plane, it is easy to optimize the distribution of the main plane interface field and improve the utilization coefficient. The used novel transmitting antenna here radiates the power uniformly through free space to the rectenna. In the power receiving subsystem, the planar array antenna is used to receive the transmitted power, whose array elements can be distinguished and designed according to the

magnitude of the power density at the receiving plane. Owing to the antenna's low unit received power and the rectifier's small single-transistor power, the microwave power should be synthesis and rectification. Last, the DC power of the rectifiers should also be synthesis with an efficient manner, which can be parallel or serial connections under the same magnitude.

### A. CASSEGRAIN ANTENNA

The configuration of the Cassegrain antenna system designed in the microwave wireless energy transmission system is as shown in Fig. 2, which includes the rotational symmetric parabolic main-reflector, the hyperbolic sub-reflector, and the feed horn, and also operates at the designed frequency ( $f = 12.75GHz$ ) [15]. Correspondingly, the rotational symmetric parabolic reflector has a focal point  $F_1$  and an aperture of  $D$ . The hyperbolic sub-reflector with  $F_1$  and  $F_2$  as its focal points shares the same focal axis and focal point with the parabolic main-reflector as in Fig. 2. The horn feed is placing at the virtual point  $F_2$  of the hyperbolic reflector. According to geometric characteristics of the parabola and hyperbola, the microwave beams originated from the feed horn are reflected by the sub-reflector, and are then reflected by the main reflector, and finally, all the microwave beams reach the aperture of the Cassegrain antenna system. In the system, all the microwave beams propagate with the same route length and reach the aperture in the same phase. According to the requirements of mechanical structure, cross polarization and the length of the feedline, there are four

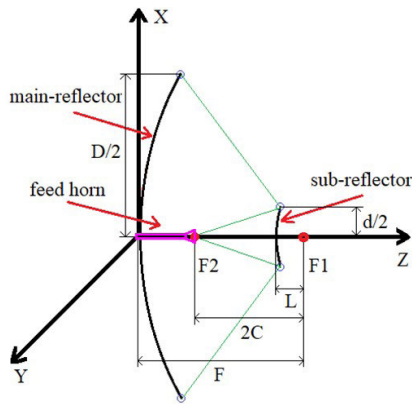

FIGURE 2. Geometry of the Cassegrain antenna system.

parameters  $D$ ,  $F$ ,  $C$  and  $L$  need to be determined, and in the letter the following values are selected:  $F = 0.75m$ ,  $C = 0.25m$ ,  $L = 0.125m$  and  $D = 1.5m$ . The feed horn adopts the Gauss horn with an aperture of 60mm, and when the edge feeding level is  $-12dB$ , the beam width of the Gauss horn is about 37.8 degrees, which is fully suitable for illuminating the hyperbolical sub-reflector surface in the Cassegrain antenna system.

In the microwave wireless transmission system, the design principle of the Cassegrain antenna system is that the output microwave beams are concentrating and the field distribution is flat with the highest efficiency as soon as possible within the designed receiving plane zone and distance, and here the designed receiving plane zone is  $2m \times 2m$  and the designed distance is 60m. The simulation and optimization are completing by using the FEKO software for obtaining the performance of the Cassegrain antenna system [16], and the normalized near radiation field amplitude along  $X$  and  $Y$  axis are shown in Fig. 3 within the designed distance and zone at the designed frequency.

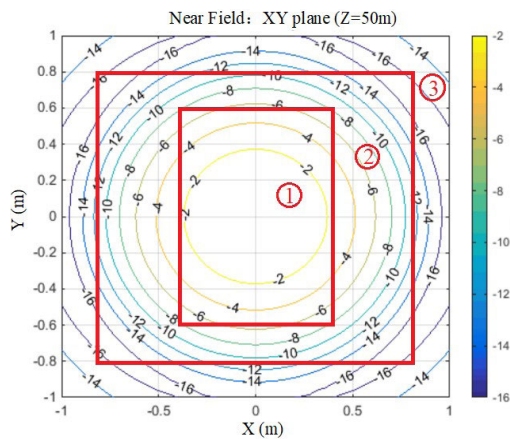

FIGURE 3. The distributions of the near radiation field at the designed distance.

The simulation result shows that the distributions of the near radiation field are significant differences at the plane of the receiving rectenna. Also due to the determinate single

receiving array unit with the same area, the output power of the single receiving array unit is proportional to the distribution of the near radiation field. In order to make full use of the performance of rectifier diode, these received single powers should be synthesized to a consistent level, and then be pumped into the rectifying diodes. In the microwave wireless energy transmission system, to reduce the difficulty and complexity of the design, the receiving plane would be divided into three regions, like the areas red marked ①, ② and ③ in the figure, and correspondingly the four ways, the eight ways and the sixteen ways power synthesizer should be designed to realize the same output power and make full use of the following rectifier. In conclusion, the Cassegrain antenna system with an aperture of 1.5m can transfer the energy to form a more centralized and uniform  $2m \times 2m$  receiving zone at 60m distance, which has a more than 80% transmission efficiency.

B. RECTENNA ARRAY

In the receiving sub-system, the rectenna adopts rectangular patches sequentially printed on the top surface of a single-layer dielectric substrate [17], [18], the relative permittivity of which is  $\epsilon_r = 2.2$  with a thickness  $h$  is 10mil. The elements are arranged in a rectangular lattice with a periodicity of 17.36mm in  $X$ -axis and 16.75mm in  $Y$ -axis. The topological structure of the proposed element shows in Fig. 4. In this configuration, the rectangular patches are used to resonance at the designed frequency, and the feed is placed in the center of the patch concerning its width  $W$ . The patch is fed along the direction of the resonance, that is parallel to its length  $L$ . The microstrip line feeds the patch, and the line is inset at the patch edge. The amount of inset  $l$  in the element is chosen to match the patch impedance with that of the feed line [19], [20]. The microstrip line feeding is perhaps the simplest and costs the least, especially which can make for a wholly printed structure [21], [22].

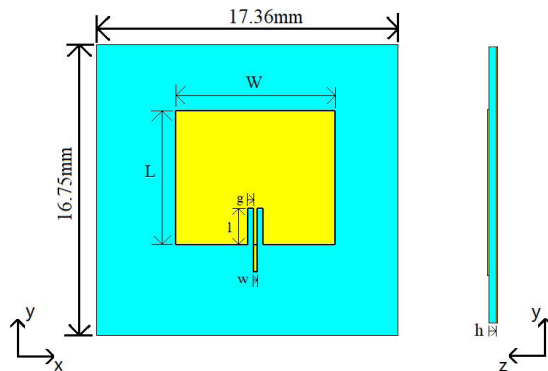

FIGURE 4. Geometry of the proposed element.

After completing the single element geometry, to increase the receiving power level at the input of the rectifier, and to be able to improve the efficiency of the rectifier, the proposed  $2 \times 2$ ,  $2 \times 4$  and  $4 \times 4$  rectangular patch antenna arrays are simulated and optimized using the high-frequency

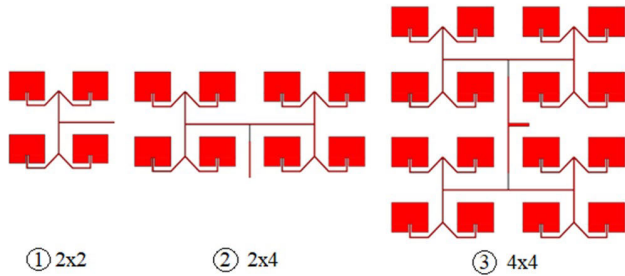

FIGURE 5. The final layout of the  $2 \times 2$ ,  $2 \times 4$  and  $4 \times 4$  rectangular patch antenna arrays and power synthesizers.

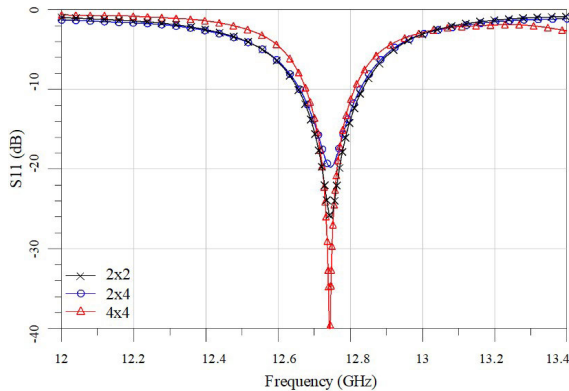
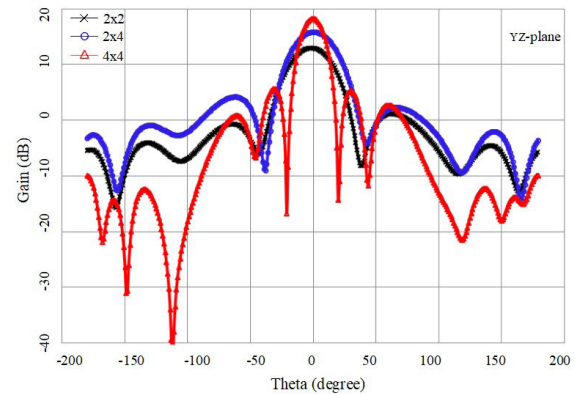

FIGURE 6. The result of the antenna array impedances matching characteristics.

structure simulator HFSS [23]. The layout of the final validated antennas structure presents in Fig. 5, which consists of the rectangular patch antenna arrays and the multiple ways power synthesizers (Four ways, eight ways, and sixteen ways synthesizers).

The simulated impedance matching characteristics ( $S_{11}$ ) as a function of frequency for  $2 \times 2$ ,  $2 \times 4$  and  $4 \times 4$  rectangular patch antenna arrays and power synthesizers are described in Fig. 6, and the results show that these antenna impedances are matched well at the designed frequency.

The simulated antenna radiation pattern of the  $2 \times 2$ ,  $2 \times 4$  and  $4 \times 4$  rectangular patch antenna arrays and power synthesizers in the XZ and YZ planes are compared in Fig. 7 (a) and (b). The results display that these antenna radiation patterns are rotationally symmetric in different planes, especially in the main lobe area, and all the peak sidelobe levels in the two planes are 15dB below the main beam levels. Furthermore, the peak gains of the  $2 \times 2$ ,  $2 \times 4$  and  $4 \times 4$  rectangular patch antenna arrays and power synthesizers are about 13.5dBi, 15.5dBi and 18.5dBi, whose gain is different by 3dB but half the area in turn. Therefore, wherever these patch antenna arrays and power synthesizers with the same area are on, they can achieve the same total gains, and then their output powers and efficiencies are just determined by the distribution of the receiving aperture field. Numbers of experimental results show that the efficiency of the receiving antenna is directly related to the performance of the wireless energy transmission system [4], [8], [9], and the same conclusion reproduces in our design. The results indicate that



(a)

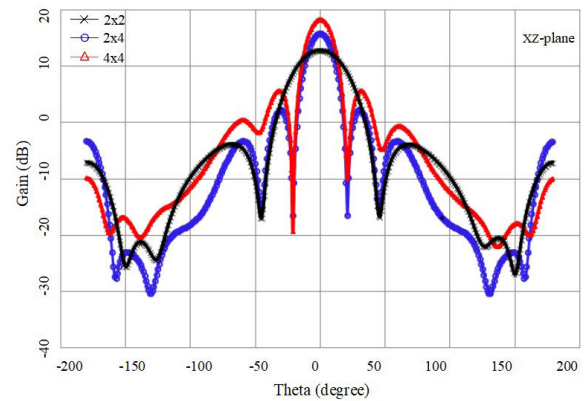

(b)

FIGURE 7. The simulated results of the gain pattern of the  $2 \times 2$ ,  $2 \times 4$  and  $4 \times 4$  rectangular patch antenna arrays and power synthesizers in the XZ plane (a) and YZ plane (b).

the receiving antenna has about 50% simulated conversion efficiency, and the measured efficiency would further reduce due to the practical insertion loss of the substrate.

### C. RECTIFIER CIRCUIT

The above rectenna receives the incident RF power under the form of the microwave and then is transformed in DC power by the diode-based rectifier. The rectifying circuit mainly consists of the matching and filtering network, the rectifying diode, the DC filtering network, and the resistive load [24], [25]. Correspondingly, the matching and filtering network ensures the impedance adaptation between the antenna and the diode rectifier for optimal power transfer and filters the higher order harmonics from reradiation [26], [27]. In the Ku-band microwave wireless energy transmission system, the topology of the rectifier circuit indicates in Fig. 8, which has minimum conduction loss and higher efficiency. The rectifying diode adopts the zero-bias Schottky diode MA4E1317 from MACOM with low series resistance, low junction capacitance and high breakdown voltage. The working rectifier frequency can operate up to 80GHz including the designed frequency, and under the magnitude of the receiving field the rectifier can be fully utilized with higher efficiency. Besides, this type of rectifier diode has been successfully

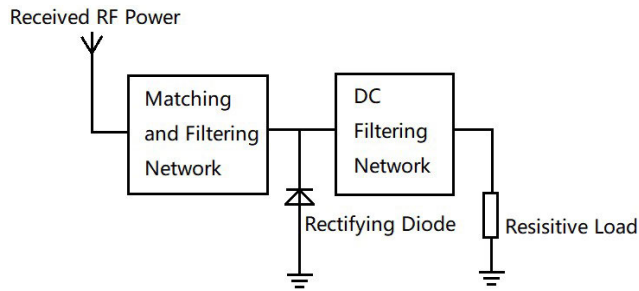

FIGURE 8. The topology of the rectifier circuit.

applied in some practical works such as in [23], [27]. The output DC filtering network effectively passes the output DC voltage and blocks the higher order harmonics. Then a resistive load places in the output terminals, which is matching the rectifier circuit and measuring the output DC power.

The high-efficiency rectifier circuit has been designed and optimized using the Advanced Design System, and fabricated on the same substrate as the above receiving rectenna [28], [29]. In the modeling process, the spice-compatible equivalent-circuit mode of the rectifier diode is adopted in the design, and the main parameters of junction capacitance, series resistance, forward voltage, reverse breakdown voltage, etc. are necessary. The fabricated prototype of the implemented rectifier presents in Fig. 9, whose operating frequency is 12.75 GHz, and they were tested stand-alone (The RF power level is directly supplied by a power source through an SMA cable) as well as connected to an external antenna.

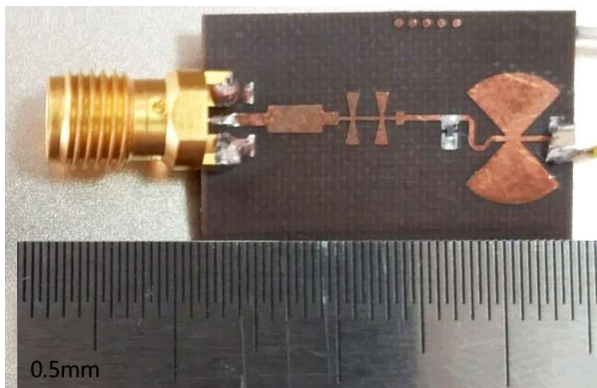

FIGURE 9. The fabricated prototypes of the implemented rectifier.

According to the magnitude of the receiving field and the optimum working interval of input power in the rectifier, the output DC power and conversion efficiency of the rectifier versus the input power (From 5dBm to 20dBm) are simulated and measured. In a wide load resistance range (From 100Ω to 200Ω ), the rectifier can obtain higher conversion efficiency. More precisely, through the comparison of experiment and simulation, the rectifier can reach the best conversion efficiency and output power at 12.57GHz with the optimal load ( $R_{load} = 150\Omega$ ) shown in Fig. 10. The results display that the characteristic change of the simulated is the same trend

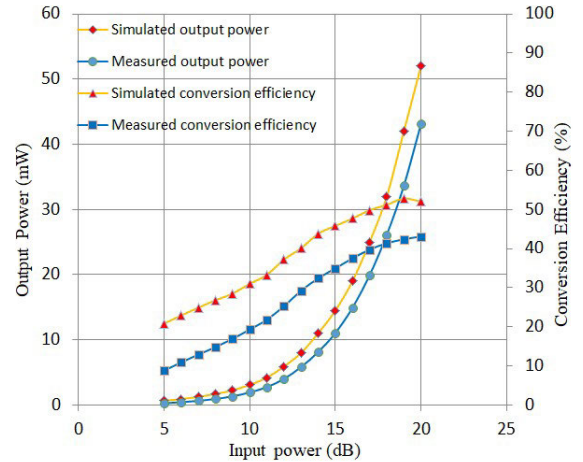

FIGURE 10. The simulated and measured output power and conversion efficiency of the rectifier at the operating frequency( $f = 12.75\text{GHz}$ ) on the optimal load ( $R_{load} = 150\Omega$ ).

as that of the measured, and the detailed analysis is that the difference between them prompts by the machining precision and dielectric insertion loss. Practically, the load resistance of the final rectifier array antenna needs to be re-optimized after DC power synthesis. In conclusion, the rectifier can achieve more than 40% conversion efficiency with the output voltage level of about 2V when the input power is between 17dBm and 20dBm, and the rectifier on the rectenna is willing to work in this ideal region with better conversion efficiency.

#### D. THE EXPERIMENT OF THE MICROWAVE WIRELESS ENERGY TRANSMISSION SYSTEM

After rectification, the straightforward combination at the DC of the signal received and converted by each antenna should be deployed [4], [30]. The main advantage of such a choice represents by its simplicity. Indeed, the antenna deployment, interconnection, and calibration are significantly simplified compared with a phased array antenna. Because the received combination signal is non-coherent, and a similar architecture through different series/parallel connection schemes has been considered to produce a high-voltage output, which can obtain a high combination efficiency of more than 94%.

Finally, the Ku-band medium and long distance microwave wireless energy transmission system based on the rectifier diode is demountable, as shown in the view of the experimental setup (Fig. 11). All the assemblies of the power transmitting subsystem and the power receiving subsystem align along the axial direction (the same direction that the microwave travels). Comparing with the conventional antenna system, this novel microwave wireless energy transmission antenna system pays more attention to the acquisition of the total energy, which is very sensitive to the distance and location of the antennas due to the directionality of the antenna and the constant magnitude of the receiving field. In the microwave wireless energy system, the microwave generator adopts the traveling wave tube, which should be supplied by 250W DC source power and can output 150W



**FIGURE 11.** The Ku-band medium and long distance microwave wireless energy transmission system based on rectifier diode.

microwave power at 12.75GHz. When the transmission distance is at 60m, the highest receiving DC power occurs at 12.75GHz, which is the same as the rectifying circuit. In order to achieve the highest efficiency, a DC high-voltage output (50V) is designed, and the measured receiving power is about 10W, corresponding with 4% DC-DC conversion efficiency. In brief, the most advantage of this system is the pursuit of the highest total system efficiency. In the literatures, most of the rectifier systems focus on the characteristics of some of their components. Only the experiments of the France National Scientific Research Center, the Japanese Mitsubishi and so on show the overall system efficiency, which are relatively low. Comparatively speaking, the system in this paper has much room for improvement in the transmission distance.

### III. CONCLUSION

This paper demonstrates a Ku-band medium and long distance microwave wireless energy transmission system based on rectifier diode, and the design and exploration of the high-efficiency rectifier diode and the novel transmitting and receiving antennas are analyzed in detail. Respectively, the Ku-band rectifying circuit is optimized and measured, and the comparing results show that the designed practical rectifier diode can obtain more than 40% conversion efficiency at the operating frequency of 12.75GHz. Also, the transmitting and receiving antennas are Cassegrain antenna and planar array antenna, respectively. The Cassegrain antenna system with an aperture of 1.5m can transfer the energy to form a more centralized and uniform  $2m \times 2m$  receiving zone at 60m distance, which has a more than 80% transmission efficiency. The receiving antenna adopts rectangular patches arrays, and according to the distribution of the near-far field at the receiving plane, multiple ways synthesizers are connected and simulated. The results predict that the efficiency of the receiving antenna is directly related to the performance of the system, which reaches 50%, not including the possible insert loss. Finally, the Ku-band medium to long distance microwave wireless energy transmission system based on the

rectifier diode is carried out. The experiment results show that the system can obtain 4% DC-DC conversion efficiency at a distance of 60m, which is likely to be used in unmanned aerial vehicle hovering charging system, robot charging while working, isolated island wireless power supplying and wireless charging of various sensors, but the compact and efficiency improvement would be the obstacle in the practical application, and it is also the further research objective and direction.

### ACKNOWLEDGMENT

The authors would like to thank Dr. Shengen Li in the Crossed Field Device Laboratory, Beijing Vacuum Electronics Research Institute, and Dr. Keying Li in 39th Research Institute of China Electronic Technology Corporation.

### REFERENCES

- [1] T. Mitani, "Demonstration experiment of microwave power and information transmission from an airship," in *Proc. 2nd Int. Symp. Radio Syst. Space Plasma*, 2010, pp. 157–160.
- [2] N. Shinohara, "Rectennas for microwave power transmission," *IEICE Electron. Exp.*, vol. 10, pp. 1–13 Nov. 2013.
- [3] X. Zhao, X. Tuo, Q. Ge, and Y. Peng, "Research on the high power cyclotron-wave rectifier," *Phys. Plasmas*, vol. 24, Jul. 2017, Art. no. 073117.
- [4] B. Massa, G. Oliveri, P. Rocca, and F. Viani, "Array designs for long-distance wireless power transmission: State-of-the-art and innovative solutions," *Proc. IEEE*, vol. 101, no. 6, pp. 1464–1481, Jun. 2013.
- [5] Y. Li, Z. He, Z. Gao, Y. Zhuang, C. Shi, and N. Ei-Sheimy, "Toward robust crowdsourcing-based localization: A fingerprinting accuracy indicator enhanced wireless/magnetic/inertial integration approach," *IEEE Internet Things J.*, vol. 6, no. 2, pp. 3585–3600, Apr. 2018.
- [6] S. S. Mohammed, K. Ramasamy, and T. Shanmuganatham, "Wireless power transmission—A next generation power transmission system," *Int. J. Comput. Appl.*, vol. 1, no. 13, pp. 100–103, Feb. 2010.
- [7] G. Pignolet, "Antenna designs for wireless power transportation : The ground Bassin case study in reunion island," in *Proc. Int. Symp. Antennas Propag.*, Sep. 1996, pp. 397–400.
- [8] A. Celeste, J.-D. L. S. Luk, and J. P. Chabriat, "The Grand-Bassin case study: Technical aspects," *Proc. Space Power Syst. Energy Space for Humanity*, 1997, pp. 255–258.
- [9] M. Furukawa, T. Minegishi, T. Ogawa, Y. Sato, P. Wang, H. Tonomura, M. Teramoto, and N. Shinohara, "Wireless power transmission to 10 kW output 2.4 GHz-band rectenna array for electric trucks application," *IEICE, Tokyo, Japan, Tech. Rep. WPT2012-7*, 2013, pp. 36–39.
- [10] J. W. Zhang, Y. Huang, and P. Cao, "An investigation of wideband rectennas for wireless energy harvesting," *Wireless Eng. Technol.*, vol. 5, pp. 107–116, Oct. 2014.
- [11] M. Balakrishnan, S. Gowthaman, S. P. J. Kumaran, and G. R. Sabhapathy, "A smart spy robot charged and controlled by wireless systems," in *Proc. Int. Conf. Innov. Inf., Embedded Commun. Syst. (ICIECS)*, Mar. 2015, pp. 1–4.
- [12] A. Khemar, A. Kacha, H. Takhedmit, and G. Abib, "Design and experiments of a dual-band rectenna for ambient RF energy harvesting in urban environments," *IET Microw. Antennas Propag.*, vol. 12, no. 1, pp. 49–55, Jan. 2018.
- [13] R. Correia, N. B. Carvalho, and S. Kawasaki, "Continuously power delivering for passive backscatter wireless sensor networks," *IEEE Trans. Microw. Theory Techn.*, vol. 64, no. 11, pp. 3723–3731, Nov. 2016.
- [14] M. Palandoken and C. Gocen, "A modified Hilbert fractal resonator based rectenna design for GSM 900 band RF energy harvesting applications," *Int. J. RF Microw. Comput. Aided Eng.*, vol. 29, no. 1, 2019, Art. no. e21643.
- [15] J. Wang, J. X. Ge, Y. Zhou, H. Xia, and X. Z. Yang, "Design of a high-isolation 35/94-GHz dual-frequency orthogonal-polarization cassegrain antenna," *IEEE Antennas Wireless Propag. Lett.*, vol. 16, pp. 1297–1300, 2017.
- [16] J. Zhao, H. Li, X. Yang, T. Li, Y. Zhou, B. Hu, H. Wang, H. Zou, and Q. Liu, "Novel mode-conversion method based on single-layer metasurface," *IEEE Trans. Antennas Propag.*, vol. 66, no. 11, pp. 6420–6424, Nov. 2018.

- [17] B. J. Delong, A. Kiourti, and J. L. Volakis, "A radiating near-field patch rectenna for wireless power transfer to medical implants at 2.4 GHz," *IEEE J. Electromagn., RF, Microw. Med. Biol.*, vol. 2, no. 1, pp. 64–69, Mar. 2018.
- [18] Q. Awais, Y. Jin, H. T. Chattha, M. Jamil, H. Qiang, and B. A. Khawaja, "A compact rectenna system with high conversion efficiency for wireless energy harvesting," *IEEE Access*, vol. 6, pp. 35857–35866, 2018.
- [19] S. Ahmed, M. N. Husain, Z. Zakaria, M. S. I. Zin, and A. Alhagazi, "Rectenna designs for RF energy harvesting system: A review," *Int. J. Commun. Antenna Propag.*, vol. 6, no. 2, pp. 82–91, Apr. 2016.
- [20] J. Zbitou, M. Latrach, and S. Toutain, "Hybrid rectenna and monolithic integrated zero-bias microwave rectifier," *IEEE Trans. Microw. Theory Techn.*, vol. 54, no. 1, pp. 147–152, Jan. 2006.
- [21] C. Liu, F. Tan, H. Zhang, and Q. He, "A novel single-diode microwave rectifier with a series band-stop structure," *IEEE Trans. Microw. Theory Techn.*, vol. 65, no. 2, pp. 600–606, Feb. 2017.
- [22] S. Malisuwan, N. Tiannara, and N. Suriyakrai, "Design of antennas for a rectenna system of wireless power transfer in the LTE/WLAN frequency band," *J. Clean Energy Technol.*, vol. 5, no. 1, pp. 42–46, Jan. 2017.
- [23] S. Ladan, A. B. Guntupalli, and K. Wu, "A high-efficiency 24 GHz rectenna development towards millimeter-wave energy harvesting and wireless power transmission," *IEEE Trans. Circuits Syst. I, Reg. Papers*, vol. 61, no. 12, pp. 3358–3366, Dec. 2014.
- [24] M. Wang, L. Yang, Y. Fan, M. Shen, Y. Li, and Y. Shi, "A compact omnidirectional dual-circinial rectenna for 2.45 GHz wireless power transfer," *Int. J. RF Microw. Comput.-Aided Eng.*, vol. 29, no. 1, 2019, Art. no. e21625.
- [25] X. Hu, T. Liu, Z. Liu, W. Wang, and F. M. Ghannouchi, "A novel single feedback architecture with time-interleaved sampling for multi-band DPD," *IEEE Commun. Lett.*, vol. 23, no. 6, pp. 1033–1036, Jun. 2019.
- [26] A. Nimo, D. Grgić, and L. M. Reindl, "Optimization of passive low power wireless electromagnetic energy harvesters," *Sensors*, vol. 12, no. 10, pp. 13636–13663, Oct. 2012.
- [27] H. Mei, X. Yang, B. Han, and G. Tan, "High-efficiency microstrip rectenna for microwave power transmission at Ka band with low cost," *IET Microw., Antennas Propag.*, vol. 10, no. 15, pp. 1648–1655, Dec. 2016.
- [28] D. Kumar and R. Veeramani, "Harvesting microwave signal power from the ambient environment," *Int. J. Commun. Comput. Technol.*, vol. 4, pp. 76–81, Dec. 2016.
- [29] D. H. Chuc and B. B. Duong, "Design and fabrication of rectifying antenna circuit for wireless power transmission system operating at ISM band," *Int. J. Elect. Comput. Eng.*, vol. 6, pp. 1522–1528, Aug. 2016.
- [30] T. Soyata, L. Copeland, and W. Heinzelman, "RF energy harvesting for embedded systems: A survey of tradeoffs and methodology," *IEEE Circuits Syst. Mag.*, vol. 16, no. 1, pp. 22–57, 1st Quart., 2016.



**BIAO HU** received the Ph.D. degree in physical electronics from the University of Electronic Science and Technology of China (UESTC), Chengdu, China, in 2014, where he is currently with the School of Electronic Science and Engineering.

From 2019 to 2020, he was a Senior Visiting Fellow with the University of Calgary, AB, Canada. His current research interests include the microwave wireless energy transmission and high

power microwave components.



**YIHONG ZHOU** received the Ph.D. degree in physical electronics from the University of Electronic Science and Technology of China (UESTC), Chengdu, China, in 2010, where he is currently with the School of Electronic Science and Engineering.

From 2014 to 2015, he was a Senior Visiting Fellow with the National University of Singapore, Singapore. His current research interests include the microwave/millimeter wave integrated circuits and antennas.



**HAO LI** received the Ph.D. degree in physical electronics from the University of Electronic Science and Technology of China (UESTC), Chengdu, China, in 2009, where he is currently with the School of Electronic Science and Engineering.

From 2015 to 2016, he was a Senior Visiting Fellow with Clemson University, Clemson, SC, USA. His current research interests include the high power microwave components, antennas, and numerical simulations in electromagnetic engineering.

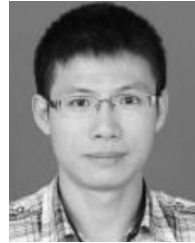

**HAIYANG WANG** received the Ph.D. degree in physical electronics from the University of Electronic Science and Technology of China (UESTC), Chengdu, China, in 2009, where he is currently with the School of Electronic Science and Engineering.

From 2013 to 2014, he was a Senior Visiting Fellow with the University of Houston, TX, USA. His current research interests include the high power microwave source devices and electromagnetic compatibility.



**TIANMING LI** received the Ph.D. degree in physical electronics from the University of Electronic Science and Technology of China (UESTC), Chengdu, China, in 2005, where he is currently with the School of Electronic Science and Engineering.

From 2011 to 2012, he was a Senior Visiting Fellow with the College of William and Mary, Williamsburg, USA. His current research interests include the high power microwave technique and its applications.



**MOHAMED HELAOUI** received the Ph.D. degree in electrical engineering from the University of Calgary, AB, Canada, in 2008, where he is currently a Professor with the Department of Electrical and Computer Engineering.

He has authored or coauthored over 150 publications, one book, three book chapters, and 11 patents applications. His current research interests include digital signal processing, power efficiency enhancement for wireless transmitters,

efficient and broadband power amplifiers, monolithic microwave integrated circuit power amplifiers for wireless and satellite communications, advanced transceiver design for software-defined radio, and millimeter-wave applications. He is the Chair of the IEEE local COM/MTT/AP joint chapter in the Southern Alberta Section.



**FADHEL M. GHANNOUCHI** is currently a Professor, the Alberta Innovate Strategic Chair of the Intelligent RF Technology, the Canada Research Chair of Green Radio Systems, and the Director of the iRadio Laboratory, University of Calgary, AB, Canada. He is also a Part-Time 1000 Talent Professor with the Department of Electronic Engineering, Tsinghua University, Beijing, China. His research interests include microwave, wireless, and optical communications. He is a Fellow of

the Institution of Engineering and Technology, the Canadian Academy of Engineering, the Engineering Institute of Canada, and the Academy of Science and Royal Society of Canada.

...