

Integrated access and backhaul

A NEW TYPE OF WIRELESS BACKHAUL IN 5G

5G New Radio introduces a new type of wireless backhaul known as integrated access and backhaul that is of particular interest for dense deployment of street-level radio nodes.

**HENRIK RONKAINEN,
JONAS EDSTAM,
ANDERS ERICSSON,
CHRISTER ÖSTBERG**

The combination of millimeter wave (mmWave) spectrum – which is becoming available globally for 5G – with other spectrum assets below 6GHz results in high speeds and capacities. The mmWave radio resources can only provide limited coverage, though, which makes it reasonable to expect a fairly low level of utilization. As a result, there is an opportunity to use an innovative type of wireless backhaul in 5G – integrated access and backhaul (IAB) – to densify networks with multi-band radio sites at street level.

■ Transport networks play a vital role in RANs by connecting all the pieces. The use of dark fiber for 5G transport is of growing importance [1], and wireless backhaul is an essential complement for sites where fiber is either not available or too costly. In fact, microwave backhaul has been the dominant global backhaul media for over

two decades and will remain a highly attractive complement to fiber for 5G transport [2].

Network densification using street-site deployments comes with new challenges, however. The allowed space and weight for equipment is limited. The installation, integration and operation must be simplified with a high degree of automation to achieve cost-efficient deployment of RAN and transport. This calls for a new type of wireless backhaul that is fully integrated with 5G New Radio (NR) access. This is where IAB enters the frame.

More than 10GHz of total bandwidth in the mmWave frequency range of 24.25GHz to 71GHz was globally identified for 5G at the ITU World Radio Conference 2019. Already today, 5GHz of mmWave bandwidth is available in the US. The best overall performance at the lowest total cost of ownership is achieved by using mmWave in combination with spectrum assets below 6GHz [1].

These assets will be deployed on macro sites (rooftops, towers) and street sites (poles, walls, strands) in urban areas with high demands on capacity and speed, as well as in suburban areas with fiber-like fixed wireless access (FWA) services [3]. IAB could provide fast deployment of mmWave backhaul for new multiband street sites, with an easy migration to fiber-based backhaul if, and when, needed.

Using radio-access technology to provide backhaul

Access spectrum has historically been too valuable and limited to use for backhauling. Its rare use today is for LTE solutions that provide a single backhaul hop using a separate frequency band from access, as shown in section A of *Figure 1*. This approach uses a fixed wireless terminal (FWT) to provide connectivity to a separate backhaul core instance. The instance could either be in the core for radio access or distributed closer to the radio nodes to support lower latency inter-site connectivity. It is also possible to use 5G NR to provide such separate access and backhaul solutions.

A solution more like IAB was studied for LTE in 3GPP release 10 in 2011, also known as LTE relaying [4], but it never gained any commercial interest. However, with the wide mmWave bandwidths now becoming available, there is considerable interest in an IAB solution for 5G NR.

The work on IAB has been going on in the 3GPP since 2017, and it is currently being standardized for release 16, targeting completion during 2020 [5, 6]. IAB can provide flexible and scalable multi-hop backhauling, using the same or different frequency bands for access and backhaul, as shown in section B of *Figure 1*.

The backhaul is efficiently forwarded across the wirelessly interconnected radio nodes, with the backhaul links terminated by an IAB mobile termination (IAB-MT) function. The IAB-MT could either use a separate antenna or share the access antenna of the base station (virtual IAB-MT). The latter provides the ultimate level of integration, as well as utilizing the high-performance base station antennas for backhaul over longer distances.

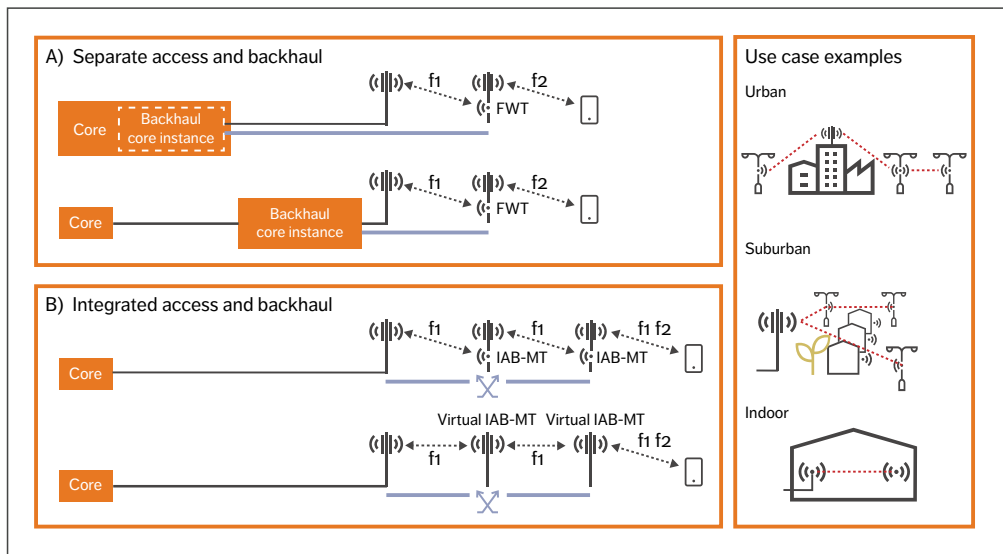

Figure 1 Solutions using radio-access technology to provide backhaul

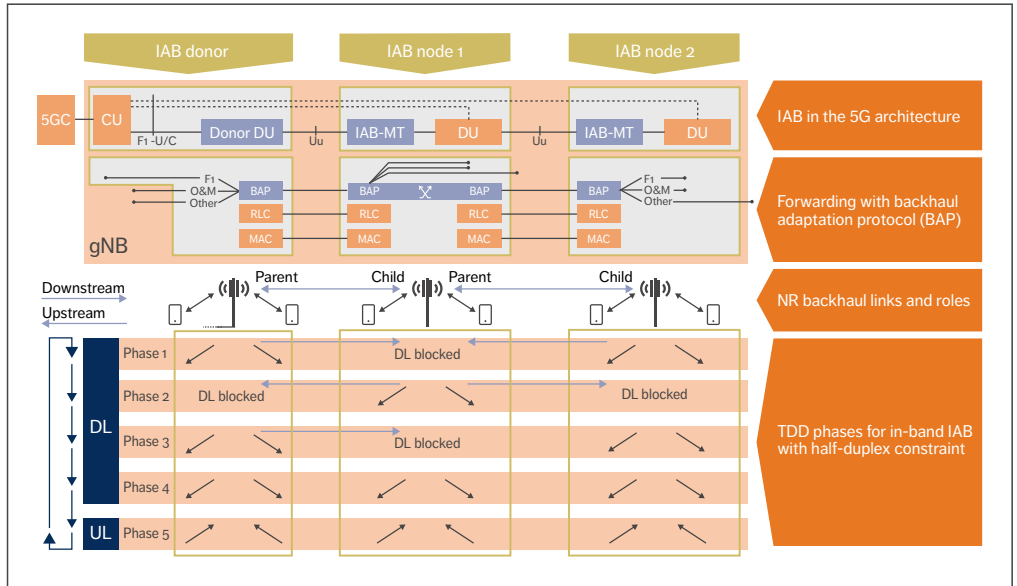

Figure 2 The 3GPP IAB concept

The IAB concept is defined by the 3GPP to be flexible and scalable to support other use cases beyond the initial market interest, such as low-power indoor radio nodes. There is also research on future advanced enhancement and optimizations for more visionary IAB use.

The 3GPP concept of integrated access and backhaul

IAB is defined to reuse existing 5G NR functions and interfaces, as well as to minimize impact on the core network. The architecture is scalable, so that the number of backhaul hops is only limited by network performance. From a transport perspective, IAB provides generic IP connectivity to enable an easy upgrade to fiber transport when needed.

In the 5G network, the gNB base station provides NR protocol terminations to the user equipment (UE) and is connected to the 5G Core (5GC) network. As defined in 3GPP TS 38.401 [7], the gNB is a logical node, which may be split into one central

unit (CU) and one or more distributed units (DU). The CU hosts the higher layer protocols to the UE and terminates the control plane and user plane interfaces to the 5GC. The CU controls the DU nodes over the F1 interface(s), where the DU node hosts the lower layers for the NR Uu interface to the UE.

As illustrated in Figure 2, the CU/DU split architecture is used for IAB and enables efficient multi-hop support. The architecture eliminates the backhaul core instance at every IAB node shown in Figure 1A and related overhead due to tunnels inside tunnels, which would become severe for large multi-hop chains.

As the time-critical functionality is located in each DU, the F1 interface is well suited for a non-ideal backhaul such as IAB. The IAB donor is a logical node that provides the NR-based wireless backhaul and consists of a CU and wire-connected donor DU(s). The IAB nodes, which may serve multiple radio sectors, are wireless backhauled to the IAB donor and consist of a DU and an IAB-MT.

All IAB-nodes and donor DU(s) that use the same CU are part of one gNB, in accordance with the CU/DU split architecture. Hence, the wireless backhaul is isolated inside the gNB, and any internal topology, routing or backhaul changes can be made without impacting the 5GC or neighboring gNBs. A similar situation is valid for the UEs, for which the IAB node appears as a normal base station, supporting both NR standalone and non-standalone mode.

As shown in Figure 2, the NR backhaul link is between a “parent” on the network side and a “child” at the other end. The DU at the parent schedules the backhaul downstream and upstream traffic to/from the IAB-MT at the child, supporting a limited subset of the NR UE functionality. This includes lower protocol layer functionality to the parent as well as Radio Resource Control and non-access stratum functionality to the IAB donor CU and 5GC.

The backhaul adaptation protocol (BAP) [11] enables efficient IP data forwarding across the IAB interconnected radio nodes, where the BAP data is carried by backhaul Radio Link Control (RLC) channels on each NR backhaul link. Multiple channels can be configured to enable traffic prioritization and QoS enforcement and, based on these properties, the BAP entity in each node maps protocol data units to the appropriate backhaul RLC channel.

Hop-by-hop forwarding, from the IAB donor to the destination IAB node, is based on the BAP routing identity set by the IAB donor. Any IP traffic can be forwarded over the BAP, such as F1 and operation and maintenance (O&M) of the IAB nodes, as well as connectivity of any other equipment at the IAB-node site, as shown in Figure 2.

Physical layer aspects

The IAB feature is intended to support out-of-band and in-band backhauling, where the latter means usage of the same carrier frequencies for both the NR backhaul links and the access links. In-band operation comes with a half-duplex constraint, implying that the IAB-MT part of an IAB node cannot receive while its collocated DU is transmitting and vice versa to avoid intra-site interference. A strict time-domain separation

is therefore required between transmission and reception phases within each IAB node.

IAB is expected to be of most benefit in mmWave spectrum, where TDD [8] is used and operators typically have large bandwidth. A TDD network is typically configured with a (often regulated) pattern for the time domain allocation of downlink (DL) and uplink (UL) resources, and an additional level of pattern must be used to support combined access and backhaul traffic. This is illustrated in the example in Figure 2, with five different repeated IAB time phases for node-local TDD states, where phases 1-4 are mapped to the DL and phase 5 to the UL.

●● IAB IS EXPECTED TO BE OF MOST BENEFIT IN MMWAVE SPECTRUM ●●

The mix and duration of different phases can be flexible depending on the scenario, access/backhaul link performance, load and so on. Due to the half-duplex constraint, there will be time periods in which the nodes are blocked from transmission in a normal DL slot, effectively reducing the peak rate for an IAB node compared with a similar node with wired (non-limited) backhaul. This occurs whenever there is a transmission over the NR backhaul link, as the receiving end of the link will not operate according to the overall TDD pattern. In the example in Figure 2, the backhaul transmission occurs in phases 1-3, and the normal DL operation is blocked for the receiving nodes (in all sectors) during these phases.

The parent node schedules all traffic over the backhaul link (phases 1-3) in the same way as for UE scheduling, where frequency division multiplexing or space division multiplexing can be used to separate simultaneous transmissions.

Deployment constraints for integrated access and backhaul

From a 3GPP architecture perspective, the IAB feature is flexible, supporting multi-hop and a variety of topologies. However, there are other aspects that

restrict the size of the IAB network topology, where in-band operation (sharing spectrum for both backhaul and access) is an essential reason for these limitations. Larger IAB topologies might also require complex control functions. But since IAB is a complement to fiber, the size of most IAB networks is expected to be small.

In a multi-DU network, the first backhaul hop must carry the backhaul bandwidth not only for the first IAB node, but also for all other IAB nodes further down in the hop chain. Deploying multi-hop networks will therefore eventually lead to backhaul-limited nodes due to congestion in the first hop. Increasing the number of hops will also increase the end-to-end latency and raise the complexity for scheduling and routing to satisfy QoS.

The 3GPP gNB synchronization requirements apply also for IAB nodes that may be fulfilled with a node-local synchronization solution based on the Global Navigation Satellite System. In some situations, this is neither wanted nor feasible. Over-the-air synchronization is therefore an alternative option, using periodic parent-transmitted reference symbols as the synchronization source for the receiving child node. This scheme implies that the clock accuracy at the donor DU must be better than the 3GPP requirement, as the synchronization budget is shared/ aggregated for all nodes using this donor DU. There are therefore several practical reasons to limit the number of hops and not deploy oversized IAB topologies.

Regardless of topology, there are also general radio aspects to consider. The 3GPP specifies radio interface requirements for the IAB-MT [8], with two categories to distinguish different use cases and characteristics. One category is for wide-area usage with planned site deployment, such as backhaul of street sites; the other is for local-area usage with site deployments that may not be preplanned.

The wide-area category enables an integrated solution for the access and backhaul links, where the IAB node can benefit from using the full base station capabilities – such as advanced antenna systems (AAS) [9] and high output power – to provide good backhaul link performance and relatively large distance between parent and child nodes.

Wide-area and local-area IAB-MT are intended for different deployment scenarios and use differing TDD patterns. In Figure 2, all backhaul link traffic is scheduled during DL timeslots but an alternative TDD scheme may be applied where the UL timeslots are used for upstream backhaul. The latter scheme is restricted in terms of output power, making it more suitable for local-area deployments.

The IAB backhaul links give rise to a semi-synchronous TDD operation, for which the regulatory framework for local coordination between operators is not yet in place in all countries [10]. As illustrated by the TDD phases in Figure 2, during certain time slots the IAB node will operate in an inverted mode with respect to the general TDD pattern. This means that a node may be in receiving mode during a DL slot for backhaul link reception and thus suffer from neighbor node interference, both within the same channel as well as between channels in the same frequency band.

Even though the backhaul link is more robust against interference due to good link budget, measures such as isolation between nodes (separation distance, for example) or coordinated TDD patterns may still be required to avoid excessive interference.

THE SIZE OF MOST IAB NETWORKS IS EXPECTED TO BE SMALL

Integrated access and backhaul from a backhaul perspective

Traditional backhaul is a service provided by the transport network domain to the radio-access nodes. For IAB, a segment of the backhaul is embedded in the RAN domain, sharing common radio resources. The backhaul transport cannot be dimensioned on an individual node basis, as the IAB donor terminates the “common backhaul” for all underlying IAB nodes extending the radio access to UEs through a network of backhaul and access links.

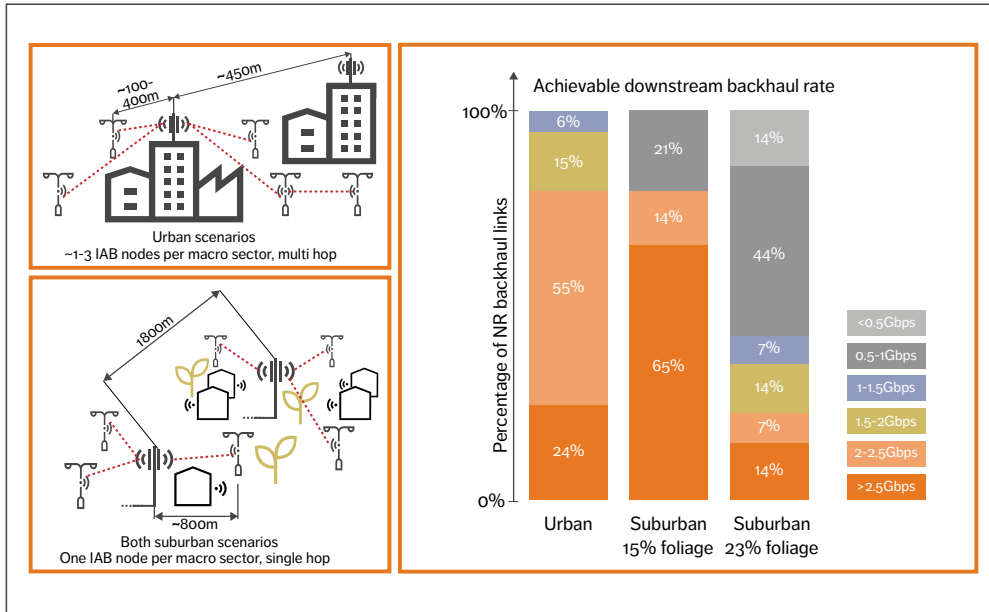

Figure 3 Simulated IAB performance for three scenarios

Instead, the backhaul dimensioning for IAB systems needs to be an integrated part of RAN dimensioning, considering the shared radio resources for backhaul and access. From a transport network perspective, the IAB nodes appear as extensions of the IAB donor. The same IP assignment methods can be used for IAB nodes as for fiber-connected radio nodes, which facilitate an easy upgrade to fiber transport when needed.

IAB can also provide IP connectivity for other equipment at the IAB node site, as shown in Figure 2. The transport performance requirements to the IAB donor are affected by the connected IAB nodes. The busy hour data traffic is funneled through the IAB donor and increases with each connected IAB node. The latency and synchronization requirements for the transport are also affected, as each IAB backhaul hop adds latency and timing error. These aspects will also limit the size of the IAB topology.

The role of integrated access and backhaul in network evolution

Densification of current networks will mainly take place in urban and dense suburban environments. As one part of assessing the role of IAB, we have performed radio network simulations of such scenarios, as illustrated in Figure 3.

When providing broadband to a home, FWA is a good alternative to fiber in many cases, as it lowers the barrier to entry and supports faster deployment [3]. In cases where the traffic demands require densification – in dense suburban areas in the US, for example – the use of wireless backhaul can further add to these advantages.

We studied FWA using IAB in simulations of two US suburban neighborhoods in the San Francisco Bay Area, with the level of foliage as the main difference: 15 and 23 percent respectively. As a reference, our estimates indicate that about half of the dense suburban areas in the US have a foliage level lower than 15 percent.

Both areas had a macro grid, with an inter-site distance of 1,800m and three sectors per site. In order to serve households with an average data consumption of 1,000GB per month, a densification was made where each macro sector provided backhaul to a street site with a single hop of about 800m, as shown in Figure 3.

All sites were deployed with 40MHz on mid band for access and 800MHz on mmWave for access and backhaul. The locations of the new street sites were chosen to secure good backhaul links from the macro sites as well as good access coverage to the homes. An ideal position can be a utility pole in line-of-sight (LOS) of the macro site with a surrounding area with few or no obstacles. Moreover, the risk of future infrastructure changes blocking the backhaul link should be considered.

In the area with less foliage, the street sites off-load the macro sites by serving around 40 percent of the households. About 80 percent of the backhaul links have a downstream rate above 2Gbps, as shown in Figure 3. Over 200 households per square kilometer could be served without IAB causing any traffic limitation, even during peak hours.

In the area with more foliage, the propagation conditions are worse both for access and backhaul. Therefore, additional street sites may be needed to meet the required capacity, which will affect the business case. It was more challenging to find street site locations with good access as well as backhaul. Around 60 percent of the backhaul links have a downstream rate below 1Gbps, which means the backhaul will consume a large part of the common

access and backhaul radio resources. Fiber backhaul is therefore recommended for such sites. For the remaining 40 percent of the sites, IAB could be a viable option, despite the amount of foliage.

In a simulation of urban London, a densification with street sites is required to extend coverage and improve mobile broadband capacity both indoors and outdoors. All sites use mid band and mmWave for access, and the mmWave is also used for backhauling between street sites and macro sites. The backhaul topology was a tree structure with one to four hops, where most sites only had a single hop.

The simulations show that the need for an LOS backhaul link is less critical in urban environments than in suburban ones, thanks to strong reflections in the city environment, making it relatively easy to find locations with good signal strength.

Furthermore, the backhaul links are shorter in an urban environment, and the impact of foliage is typically less significant due to fewer trees. Figure 3 shows the achievable downstream backhaul link rates for the urban case, which are all above 1Gbps. Eighty percent are above 2Gbps. The densified network provides excellent coverage and capacity for both outdoor and indoor users, even though IAB consumes part of the spectrum.

For both suburban and urban scenarios, these simulations show that IAB is an attractive complement to fiber, with the ability to provide backhaul in the early years until traffic growth requires all radio resources to be used for access. Depending on the subscriber distribution, IAB may not even need to be replaced by fiber at some sites.

Terms and abbreviations

5GC – 5G Core | **AAS** – Advanced Antenna System | **BAP** – Backhaul Adaptation Protocol | **CU** – Central Unit | **DL** – Downlink | **DU** – Distributed Unit | **F1** – Interface CU–DU | **FWA** – Fixed Wireless Access | **FWT** – Fixed Wireless Terminal | **gNB** – gNodeB | **IAB** – Integrated Access and Backhaul | **LOS** – Line-of-Sight | **MAC** – Medium Access Control | **mmWave** – Millimeter Wave | **MT** – Mobile Termination | **NR** – New Radio | **O&M** – Operation and Maintenance | **PoC** – Proof of Concept | **RLC** – Radio Link Control | **TDD** – Time Division Duplex | **UE** – User Equipment | **UL** – Uplink | **Uu** – radio interface between RAN and UE

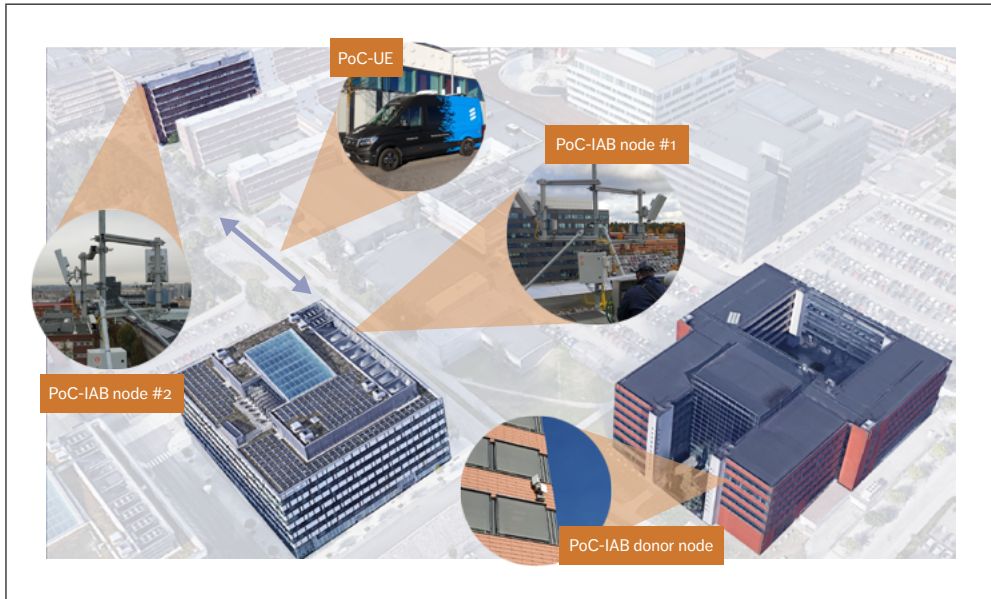

Figure 4 Deployment of the IAB testbed in Stockholm

As the backhaul link uses parts of the available spectrum resources, the typical rates for users in cells served by donors or IAB nodes will be lower than if all nodes are fiber connected. Still, with the small scale network topologies used in the simulations, we achieve peak user throughputs far above 1Gbps.

Proof of concept

In order to properly assess IAB-specific performance aspects, Ericsson has developed an IAB proof of concept (PoC) testbed in an authentic environment. At the Ericsson site in Stockholm we have set up a two-hop IAB deployment using two-sector IAB nodes with either 28GHz or 39GHz AAS radios with 100MHz bandwidth, as shown in *Figure 4*.

The IAB nodes are in the wide-area category with NR backhaul links using DL slots for all transmitted data. Initial test results are aligned with expectations and show backhaul bitrates near the predicted and end-to-end peak rates independent of hop level.

Conclusion

The massive amount of mmWave spectrum that is becoming available globally will spark a wide variety of innovative 5G use cases. Integrated access and backhaul (IAB) is one such innovation that could enhance 5G New Radio to support not only access but also wireless backhaul.

Our radio network simulations show that IAB could serve as a versatile backhaul option for street sites in urban and suburban areas, using small-scale star and tree backhaul topologies. It could also be useful for temporary deployments for special events or emergency situations.

Point-to-point microwave backhaul will remain an essential complement to fiber for 5G transport for traditional macro sites, while IAB is a promising advanced concept that may become as important for wireless backhaul of street sites.

References

1. Ericsson Technology Review, 5G New Radio RAN and transport choices that minimize TCO, November 7, 2019, Eriksson, A.C; Forsman, M; Ronkainen, H; Willars, P; Östberg, C, available at: <https://www.ericsson.com/en/reports-and-papers/ericsson-technology-review/articles/5g-nr-ran-and-transport-choices-that-minimize-tco>
2. Ericsson Microwave Outlook 2018 report, available at: <https://www.ericsson.com/en/reports-and-papers/microwave-outlook/reports/2018>
3. Ericsson Mobility Report, Making fixed wireless access a reality, November 2018, available at: <https://www.ericsson.com/en/mobility-report/articles/fixed-wireless-access>
4. 3GPP TR 36.806, Relay architectures for E-UTRA (LTE-Advanced), available at: <https://www.3gpp.org/dynareport/36806.htm>
5. IEEE, Ericsson Research, Integrated Access Backhauled Networks, Teyeb, O; Muhammad, A; Mildh, G; Dahlman, E; Barac, F; Makki, B, available at: <https://arxiv.org/ftp/arxiv/papers/1906/1906.09298.pdf>
6. Ericsson Technology Review, 5G evolution: 3GPP releases 16 & 17 overview, March 9, 2020, Peisa, J; Persson, P; Parkvall, S; Dahlman, E; Grøvlén, A; Hoymann, C; Gerstenberger, D, available at: <https://www.ericsson.com/en/reports-and-papers/ericsson-technology-review/articles/5g-nr-evolution>
7. 3GPP TS 38.401, NG-RAN; Architecture description, available at: <https://www.3gpp.org/dynareport/38401.htm>
8. 3GPP TS 38.174, Integrated access and backhaul radio transmission and reception, available at: <https://www.3gpp.org/dynareport/38174.htm>
9. Ericsson white paper, Advanced antenna systems for 5G networks, von Butovitsch, P; Astely, D; Friberg, C; Furuskär, A; Göransson, B; Hogan, B; Karlsson, J; Larsson, E, available at: <https://www.ericsson.com/en/reports-and-papers/white-papers/advanced-antenna-systems-for-5g-networks>
10. ECC Report 307, Toolbox for the most appropriate synchronisation regulatory framework including coexistence of MFCN in 24.25-27.5 GHz in unsynchronised and semi-synchronised mode, March 6, 2020, available at: <https://www.ecodocdb.dk/download/58715ebf-a1e3/ECC%20Report%20307.pdf>
11. 3GPP TS 38.340, NR; Backhaul Adaptation Protocol, available at: <https://www.3gpp.org/dynareport/38340.htm>

Further reading

- » Ericsson, Building 5G networks, available at: <https://www.ericsson.com/en/5g/5g-networks>
- » Ericsson, Microwave backhaul, available at: <https://www.ericsson.com/en/networks/trending/hot-topics/microwave-backhaul>
- » Ericsson, Fixed wireless access, available at: <https://www.ericsson.com/en/networks/offerings/fixed-wireless-access>
- » Ericsson, 5G access, available at: <https://www.ericsson.com/en/networks/offerings/5g>

THE AUTHORS



Henrik Ronkainen

◆ joined Ericsson in 1989 to work with software development in telecom control systems and later became a software and system architect for the 2G and 3G RAN systems. With the introduction of High Speed Downlink Packet Access, he worked as a system architect for 3G and 4G UE modems. Ronkainen currently serves as a system designer at Business Area Networks, where his work focuses on analysis and solutions related to the architecture, deployment and functionality required by 5G RAN. He holds a B.Sc. in electrical engineering from Lund University in Sweden.

Jonas Edstam

◆ joined Ericsson in 1995 and currently works with portfolio management at Business Unit Networks. He is also an expert on wireless backhaul, with more than

25 years of experience in this area. Throughout his career, he has served in various leading roles, working on a wide range of topics.



His current focus is on 5G NR and the strategic evolution of mobile networks and fixed wireless applications. Edstam holds a Ph.D. in physics from Chalmers University of Technology in Gothenburg, Sweden.



Anders Ericsson

◆ joined Ericsson in 1999 and currently works as a system designer at Business Area Networks. During his time at Ericsson, he has worked at Ericsson Research

and in system management, as well as heading up the Algorithm and Simulations department at Ericsson Mobile Platforms/ST-Ericsson. Ericsson holds a Licentiate Eng. in automatic control and an M.Sc. in applied physics and electrical engineering from Linköping University, Sweden.



Christer Östberg

◆ is an expert in the physical layer of radio access at Business Area Networks, where he is currently focusing on analysis and solutions related to the architecture, deployment and functionality required by 5G RAN. After first joining Ericsson in 1997 to work with algorithm development, he later became a system architect responsible for the modem parts of 3G and 4G UE platforms. Östberg holds an M.Sc. in electrical engineering from Lund University.

The authors would like to thank

Anders Furuskär,
Jialu Lun,
Birgitta Olin,
Per Skillermark,
Johan Söder,
Allan Tart and
Sten Wallin for
their contributions
to this article.