

Development and testing of a prototype of a dental extraction trainer with real-time feedback on forces, torques, and angular velocity

Maaïke G. Beuling, Tom C.T. van Riet, Jan van Frankenhuyzen, Reinier van Antwerpen, Bas de Blocq van Scheltinga, Arnout H.H. Dourleijn, Dzan Ireiz, Sander Streefkerk, Jonathan C. van Zanten, Jan de Lange, Jens Kober, Dimitra Dodou

Abstract— The need for a training modality for tooth extraction procedures is increasing, as dental students do not feel properly trained. In this study, a prototype of a training setup is designed, in which extraction procedures can be performed on jaw models and cadaveric jaws. The prototype was designed in a way that it can give real-time feedback on the applied forces in all three dimensions (buccal/lingual, mesial/distal, and apical/coronal), torques, and angular velocity. To evaluate the prototype, a series of experimental extractions on epoxy models, conserved jaws, and fresh frozen jaws were performed. Extraction duration (s), angular velocity (degrees/s), average force (N), average torque (Nm), linear impulse (Ns), and angular impulse (Nms) were shown in real-time to the user and used to evaluate the prototype. In total, 342 (92.9%) successful extractions were performed using the prototype (n= 113 epoxy factory-made, n=187 epoxy re-used, n=17 conserved, n=25 fresh frozen). No significant differences were found between the conserved and the fresh frozen jaws. The fresh frozen extraction duration, linear impulse, and angular impulse differed significantly from the corresponding values obtained for the epoxy models. Extractions were successfully performed, and the applied forces, torques, and angular velocity were recorded and shown as real-time feedback using the prototype of the dental extraction trainer. The feedback of the prototype is considered reliable.

Clinical Relevance— The prototype of the presented dental trainer might be of potential added value in dental education for teaching extraction skills.

I. INTRODUCTION

For almost all dental procedures, valuable preclinical teaching tools are available to prepare students for the clinical phase. These modern teaching tools range from basic phantom heads to advanced simulators [1]. For example, dental students can practice their preparation skills on a simulation device such as the ‘Simodont’ for restorative dentistry [2]. Also, augmented virtual reality shows potential to be used in preclinical dentistry [3]. Preclinical training is inseparable from dental care training and improves patient safety [4].

Even though there has been much development in dental education in the last decades, the way tooth extraction techniques are taught has not changed much [5]. Some preclinical models are available but are not widely used [5]. A questionnaire among European dental students showed they do

not always consider preclinical models as a useful preparation, and current education is not well appreciated [5]. On top of that, students report that they do not feel properly trained in tooth extraction, whilst this should be considered a basic skill in which every dentist must gain sufficient competency according to European standards [5-6].

Dental graduates who are not confident doing tooth extractions might be one of the causes of increased referrals to oral and maxillofacial surgeons (OMF). A study at a Dutch OMF department found an increase of more than 50% for non-surgical extractions between 1996 (16.5%) and 2014 (36.9%). This increase in referrals might negatively affect healthcare costs [7].

Recent efforts in studying tooth removal delivered new insights into these complex procedures [8]. In this study, a prototype of a dental extraction trainer is presented specifically to train tooth extraction techniques. A jaw mount is designed that can fixate both preclinical models and cadaveric jaws. The trainer is also able to supply the student with real-time feedback on the forces, torques, and angular velocity. The aim of this study was to evaluate the prototype of this dental extraction trainer so that it can be further optimized for dental education. The design is critically evaluated, and the results of a series of experiments on epoxy models, conserved human jaws, and fresh frozen jaws are discussed.

II. MATERIAL AND METHODS

A. Design of the Training Prototype

The designed setup consisted of a jaw mount with a built-in six-degrees-of-freedom force-torque sensor, a motion tracking system and a system which collected and displayed the generated data. The different components of the device will be explained in the following sections. The prototype was designed considering: rigid fixation of different materials (human and epoxy models), no restriction of the user’s hand movements, an ergonomic position of the user, and ease of use.

j.delange}@amsterdamumc.nl

Jan van Frankenhuyzen, Reinier van Antwerpen, Bas de Blocq van Scheltinga, Arnout H.H. Dourleijn, Dzan Ireiz, Sander Streefkerk, Jonathan C. van Zanten, Jens Kober, Dimitra Dodou are with the faculty of 3mE of Delft University of Technology, Mekelweg 2, 2628 CD, Delft {j.kober, d.dodou}@tudelft.nl

*Research supported by Innovation Impuls 2021, AmsterdamUMC, projectname ‘onderwijsvernieuwing vernieuwing op het gebied van extractieleer’ (in english: ‘education development of exodontia’)

Maaïke G. Beuling, Tom C.T. van Riet, Jan de Lange are with the department of Oral and Maxillofacial Surgery of the Amsterdam University Medical Center and the Academic Centre for Dentistry Amsterdam (ACTA), Meibergdreef 9, 1105 AZ, Amsterdam {m.g.beuling, t.c.vanriet,

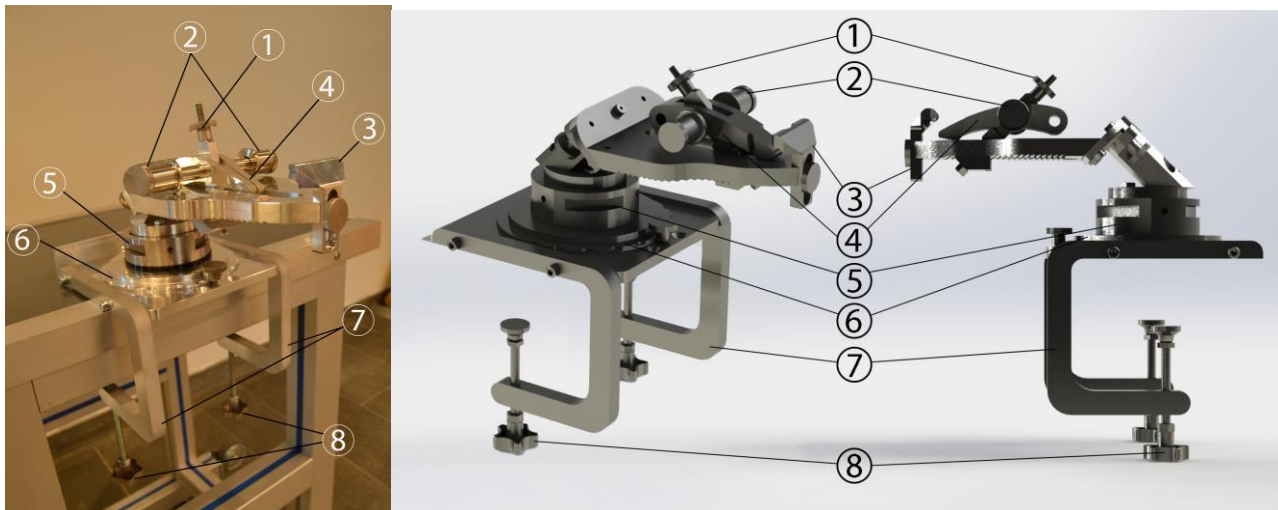

Figure 1: Jaw mount. (1) palatal mount clamping bolt, (2) axle boxes, (3) chin mount, (4) palatal mount, (5) six degrees-of-freedom force/torque sensor, (6) rotatable base (7) table mount claws, (8) table mount adjustment screws

1) Jaw Mount

Fig. 1 shows the design of the jaw mount. The jaw mount was designed to fixate both lower and upper jaws, as well as cadaveric human jaws and epoxy jaws. The jaw mount was rotatable, so a clinical representative upper and lower jaw position could be reached. In addition, a rotation around its axis on a base plate facilitated an ergonomic stance. The fixation of the different jaw types was made possible by using different clamps—all provided in one system. The system was built in such a way that the range of motion of the fixed jaw is reduced to a minimum because rigid fixation is necessary for reliable measurement of the applied forces.

2) Force Torque Sensor

A six-degrees-of-freedom (DoF) force-torque sensor (Schunk FT3176, ATI industrial automation 16 bit Delta transducer) was used to record forces and torques in three dimensions at 20 Hz. The sensor was located within the jaw mount. Because each tooth has a different location relatively to the sensor, translation and transformation of the recorded data are required. Torques and forces exerted on the sensor were translated to the ones exerted on the dental elements via rotation and translation matrices, as well as the absolute location of the dental element. The different locations of each element of the plastic teeth relatively to the position of the force-torque sensor were determined once, as they have a standard location. The location of each element of the human material was measured on a case-to-case basis, as the location differs for each tooth. The location was determined 2 mm from the incisal edge or the occlusal surface.

3) Motion Tracking System

The motion tracking system provided information about the angular velocity of the hand and, therefore, the forceps. The motion tracking system consisted of a gyroscope and accelerometer (ARCELI GY-521 MPU-6050) attached to the user's hand. The generated data of the accelerometer and gyroscope was passed

through an Arduino minicomputer (ATMEGA328P, Arduino Nano) to the computer to provide direct insight. The motion tracking system was also able to provide information about the direction of the movement. However, these recorded movements could not be translated into clinically relevant movements, as they are relative to the initial position of the hand, which differs between extractions. Therefore, the motion tracking was only used to calculate the angular velocity.

4) Data Collection

The data were collected using Python 3.7 [9]. The data were directly translated, so the system delivers real-time feedback to the user both during and after the tooth extraction via a graphical user interface (GUI). During a tooth extraction, the real-time recording, as well as the last 5 s of the three clinically most important forces/torques and rotations (i.e., the coronal/apical force and the buccal/lingual and twisting torques) were shown. After the extraction was finished, the data were saved to a .csv file, and a graphical overview of all measured forces and rotations during the procedure was shown on the GUI. An example of the provided feedback is shown in Fig. 2.

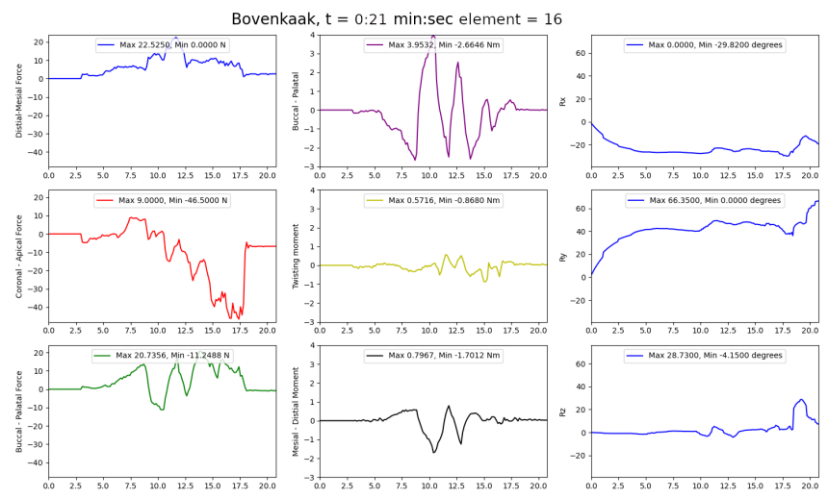

Figure 2. Example of the graphical user interface during the extraction of element 16

B. Details of the Experiments

Experiments were performed on extraction models (Frasaco A-E K extraction model, Frasaco GmbH, Tettngang, Germany) consisting of 32 plastic teeth in cast aluminium and embedded in resistant epoxy. A distinction was made between ‘first use’ or factory-prepared models (noted as factory-made epoxy) and re-used models (noted as re-used epoxy) in which the epoxy was renewed according to the included manual. The prototype was also tested with cadaver jaws to investigate whether it is suitable to fixate cadaver material. Both fresh frozen and conserved jaws were used. Clinical findings in terms of brittleness, representativeness, and forces necessary for the removal of the teeth for both samples were noted to see if this could be objectified in the data analysis. Samples were obtained through the body donation program from the Department of Medical Biology, Section Clinical Anatomy and Embryology, Amsterdam UMC at the Academic Medical Center in The Netherlands. The bodies from which the samples were taken were donated to science in accordance with Dutch legislation and the regulations of the medical ethical committee of the Amsterdam UMC at the location Academic Medical Center. In total, four sets (i.e., upper and lower) of factory-made epoxy jaws, six sets of re-used epoxy jaws, one set of human conserved and one set of human fresh frozen jaws were used. Two surgeons (authors TvR and JdL) performed all the extractions to reduce inter-operator variability.

All types of elements were included. Of all included extraction procedures, information about the material and element type (using the FDI World Dental Federation notation/ISO 3950 notation) was manually registered. The recorded data of the extraction procedure included the extraction duration, the applied forces and torques, and the angular velocity. The extraction duration was measured in seconds (s) and was defined as the time between the first and the last measured force change. The forces were recorded in Newton (N) and the torques in Newton meter (Nm). Forces and torques were translated to buccal/lingual, coronal/apical, and mesial/distal directions. The angular velocity was recorded in degrees per second (deg/s).

Attempts where the tooth fractured, the surgeon experienced a large amount of slippage of the forceps (extraction failure), or the software or hardware malfunctioned were determined as unsuccessful. These were excluded for statistical analyses, and the reason for exclusion was noted.

C. Data Processing and Statistical Analyses

The raw data was processed using Python 3.7, NumPy and Pandas [9-11]. The data was manually trimmed to exclude the periods before the start and after the end of the actual experiment (Fig. 3). The following variables were calculated and analyzed: average force (N), average torque (Nm), linear impulse (Ns), angular impulse (Nms), and average angular velocity (deg/s). The linear impulse represents the sum of all delivered forces, and the angular impulse represents the sum of all delivered torques. The average forces, torques, and angular velocity were based on the measured forces, torques, and angular velocity in all three dimensions. Results in the directions (buccal/lingual, apical/coronal, and distal/mesial) of the forces and torques are not presented in this paper for readability. Statistical analyses were computed using SPSS (SPSS version 27, IBM Inc, Phoenix USA) for Windows. Of

the different types of materials, fresh frozen was considered the golden standard. Accordingly, the factory-made epoxy, re-used epoxy, and conserved cadaver jaws were compared with the fresh frozen jaws using the independent-samples t-test. p-values < 0.05 were considered statistically significant.

III. RESULTS

A. Base characteristics of the Experiments

In total, 368 procedures were started in 12 sets of upper and lower jaws. Of these, 342 experiments were successful (92.9%). Table I shows the characteristics of the dataset, as well as reasons for failure. Five out of the six tooth fractures occurred in the extractions of the conserved jaw. The conserved upper jaw had to be re-fixated after force had been applied to one of the molars. Seven out of the eight extraction failures were caused by excessive slippage of the forceps. One extraction failure was caused by dysfunction of the epoxy material, as there was no resistance of the material on the element extracted. Causes of software or hardware malfunction varied, from incorrectly saved data to disconnection of one of the sensors during the procedure.

TABLE I. CHARACTERISTICS OF THE DATASET

Material type	Element group	Number of total extraction attempts	Successful extractions (number and %)	Unsuccessful extractions		
				Tooth fracture	Software/Hardware failure	Extraction failure
Fresh Frozen	Incisor	8	8 (100%)			
	Cuspid	2	2 (100%)			
	Premolar	8	7 (87.5%)			1
	Molar	8	8 (100%)			
	Total	26	25 (96.1%)			1
Conserved	Incisor	8	8 (100%)			
	Cuspid	4	4 (100%)			
	Premolar	5	4 (80%)	1		
	Molar	5	1 (20%)	4		
	Total	22	17 (77.3%)	5		
Epoxy (factory-made)	Incisor	32	26 (81.3%)	1	3	2
	Cuspid	16	12 (75%)		2	2
	Premolar	32	29 (90.6%)		3	
	Molar	48	46 (95.8%)		2	
	Total	128	113 (88.3%)	1	10	4
Epoxy (re-used)	Incisor	48	46 (95.8%)			2
	Cuspid	24	24 (100%)			
	Premolar	48	48 (100%)			
	Molar	72	69 (95.8%)		2	1
	Total	192	187 (97.4%)		2	3
Total		368	342 (92.9%)	6	12	8

B. Analysis of Forces, Torques, and Angular Velocity

Table II shows the mean, standard deviations and ranges of the recorded data. Teeth in both epoxy groups (factory-made: mean = 9.39 s, SD = 5.66 s; re-used: mean = 6.79 s, SD = 4.22 s) were removed significantly faster compared to fresh frozen teeth (mean = 16.01 s, SD = 8.83 s). The minimum values

TABLE II. FRESH FROZEN COMPARED TO CONSERVED, FACTORY-MADE EPOXY, AND RE-USED EPOXY * < 0.05 , ** < 0.01 , *** < 0.001

	<i>n</i>		Extraction duration [s]	Average angular velocity [deg/s]	Average force [N]	Average torque [Nm]	Linear impulse [Ns]	Angular impulse [Nms]
Fresh frozen	25	Mean	16.01	5.15	4.32	0.27	443.40	30.03
		<i>SD</i>	8.83	1.79	1.39	0.15	318.44	29.43
		Range	5.18–38.19	2.02–9.12	2.09–7.48	0.09–0.68	102.50–1208.93	5.86–120.36
Conserved	17	Mean	13.12	4.90	5.12	0.33	458.91	29.79
		<i>SD</i>	9.16	1.23	2.61	0.15	470.43	29.54
		Range	5.19–36.03	3.02–6.96	2.40–10.94	0.14–0.69	86.38–1780.47	5.86–104.75
vs. fresh frozen		<i>p</i> -value	0.312	0.620	0.259	0.197	0.899	0.979
Factory-made	113	Mean	9.39	5.75	4.27	0.23	247.37	14.26
		<i>SD</i>	5.66	2.41	1.48	0.09	171.76	12.17
		Range	1.70–30.61	2.40–16.85	1.59–9.44	0.04–0.43	41.08–874.77	1.24–58.57
vs. fresh frozen		<i>p</i> -value	0.001**	0.236	0.878	0.287	0.006**	0.014*
Re-used	187	Mean	6.79	5.33	3.72	0.17	153.46	7.61
		<i>SD</i>	4.22	1.84	1.44	0.07	107.36	7.83
		Range	1.05–31.73	1.11–14.84	1.34–10.22	0.05–0.50	12.84–610.68	0.47–72.66
vs. fresh frozen		<i>p</i> -value	< 0.001 ***	0.631	0.052	0.005**	< 0.001 ***	< 0.001 ***

found in the epoxy groups were 1.7 s and 1.05 s, showing the relative ease of some experiments with the epoxy jaws.

Whilst the average forces and torques in factory-made epoxy (force: mean = 4.27 N, SD = 1.48 N; torque: mean = 0.23 Nm, SD = 0.09 Nm) were comparable to fresh frozen material (force: mean = 4.32 N, SD 1.39 N), average forces and torques were markedly lower in re-used epoxy (force: mean = 3.72 N, SD = 1.44 N; torques: mean = 0.17 Nm, SD = 0.07 Nm). Linear impulse and angular impulse were significantly lower compared to fresh frozen in both factory-made and re-used epoxy. The total force was 65% lower in the re-used epoxy extractions (linear impulse: mean = 153.46 Ns,

SD = 107.36 Ns) than for the extractions of the fresh frozen teeth (linear impulse: mean = 443.40 Ns, SD = 318.44 Ns). The average angular velocity did not vary significantly between epoxy and fresh frozen material, although the range was much smaller in human material cases. Maximum recorded angular velocities were over 50% higher in the epoxy models. No significant effects were found between the fresh frozen and the conserved jaws for any of the recorded variables.

Fig. 3 shows the total linear and angular impulse for all successfully extracted elements. No distinction was made between upper and lower jaws and left and right elements,

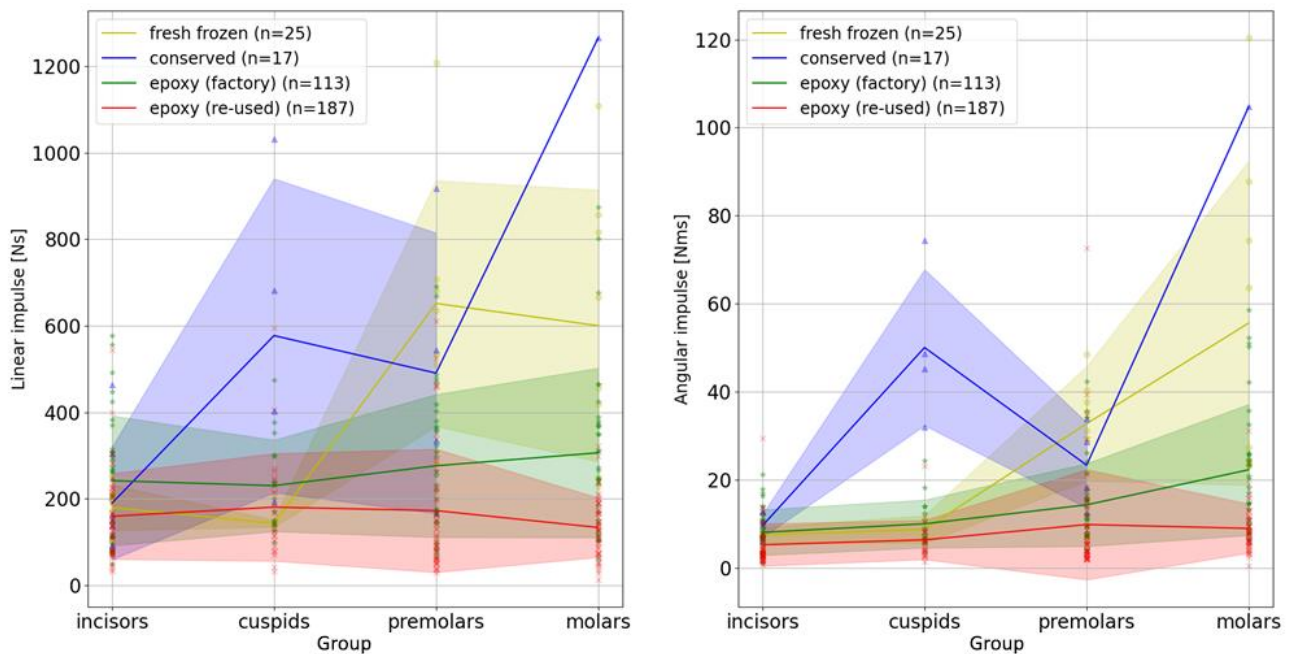

Figure 3. Linear [Ns] and angular impulse [Nms] per element group. Markers denote single measurements, the lines denote the mean, and the shaded areas denote the standard deviation (SD).

resulting in four teeth groups (incisors, cuspids, premolars, and molars) shown on the x-axis. It can be seen that the forces and torques needed for extractions of elements from the epoxy jaws were relatively similar for all elements. For the human (conserved and fresh frozen) elements, large variability in the total needed forces and torques was observed.

IV. DISCUSSION

The aim of this study was to evaluate a prototype of a training setup for tooth extraction. A prototype of a dental trainer was presented, which provides the user with (real-time) feedback on the applied forces and torques in all three dimensions and the angular velocity. The setup was designed to rigidly fixate both human jaws and epoxy models. 92.9% of all experiments were recorded successfully. During the extractions, the surgeon was allowed to move freely, and the setup was adjustable in such a way that an ergonomic pose could be adopted.

Based on their prior clinical experience, the two surgeons involved in the study reported a subjective difference in terms of extraction difficulty between different kinds of extractions. The experiment setup allowed investigating whether these subjective ideas could be objectified. Firstly, the clinical experience of the surgeons suggested that extractions on epoxy models were 'easier' compared to the more clinical representative fresh frozen models. This remark is well in line with our results, in which the extraction duration on re-used epoxy models was 50% lower than that for fresh frozen tooth extractions. In some cases, plastic teeth were removed within 2 s. Moreover, the sum of forces and torques necessary for fresh frozen tooth extractions, especially for the molars and premolars, were significantly higher than the corresponding values for the epoxy models. Also, the variability of the average force was smaller for epoxy jaws as compared to the human jaws, which can be explained by the factors influencing the procedures in human jaws, such as periodontal health and differences in root length, shape, and configuration (Fig. 4). These findings are consistent with Hanson et al. [12], in which students were asked about the difference in extraction between Thiel-embalmed cadavers and the same epoxy models as those used in our study. 73% of the students agreed that the cadaveric extraction was more difficult than the extractions in epoxy models [12].

Another subjective difference reported by the two surgeons in our study was between conserved and fresh frozen jaws. Specifically, conserved teeth were perceived as stiffer or more brittle, requiring lengthier extractions and higher extraction forces compared to fresh frozen ones. These perceived differences were not supported by the data presented in Table II, where forces and torques did not differ significantly, which might have to do with the (very) small sample size and the fact that the teeth eligible for inclusion in our analysis were positioned more anteriorly in the conserved group than in the fresh frozen group. On the other hand, Table I shows that a lot more failures (i.e., all tooth fractures) were present in the conserved group, which is well in line with the above-mentioned self-reported clinical experience and would potentially make conserved jaws a less ideal group for tooth removal education.

Lastly, the measured angular velocity did not differ between the different types of material, likely because the surgeons were experienced. The angular velocity might still be interesting for the training setup because it can potentially differentiate between students and more experienced surgeons.

Compared with other studies, this was the first dental trainer that provided real-time feedback during an extraction procedure. This makes it difficult to compare it to previous work. In a recent study [13], forces exerted by clinicians with different levels of experience were evaluated in a laboratory setting. The average force applied on the simulator in all three dimensions ranged from 18.3 N to 20.7 N between the different groups of clinical experience. These forces are much higher compared to our results. The discrepancy can be caused by the difference in study design (*ex vivo* versus *in vitro*) but also because forces in [13] were simulated on a mandibular first molar only, instead of an average of all teeth as in the present study.

There are some improvements necessary, in terms of both hardware and software. In terms of software, the current way feedback is provided might not be easy to interpret for dental students. It is necessary to develop an intuitive interface for the future training setup to adequately provide dental students with feedback in the form of visual or auditory signals, for example. Moreover, the dataset needs to be expanded to make it more generalizable. In terms of hardware, rigidly fixating the conserved upper jaw initially failed. The needed re-fixation of the conserved upper jaw might have been the consequence of the high force needed to extract the molars. The design of the two clamping arms should be improved to increase the shear resistance in the final version of the setup.

In conclusion, a prototype for a training modality for tooth extraction removal was presented and tested. The setup functions well in terms of the rigid fixation of plastic and cadaver material. The outcomes seem reliable and in line with subjective differences between epoxy and cadaver jaws based on the clinical experience of the surgeons. However, further development and testing of the training modality are necessary to optimize the setup for dental students and evaluate whether it is a useful training tool to improve their tooth extraction skills.

REFERENCES

- [1] Fugill M. Defining the purpose of phantom head. *Eur J Dent Educ*. 2013 Feb;17(1):e1-4. doi: 10.1111/eje.12008. Epub 2012 Oct 24. PMID: 23279394.
- [2] de Boer IR, Bakker DR, Wesselink PR, Vervoom JM. De Simodont in het onderwijs [The Simodont in dental education]. *Ned Tijdschr Tandheelkd*. 2012 Jun;119(6):294-300. Dutch. doi: 10.5177/ntvt.2012.06.12105. PMID: 22812267.
- [3] Plessas A. Computerized Virtual Reality Simulation in Preclinical Dentistry: Can a Computerized Simulator Replace the Conventional Phantom Heads and Human Instruction? *Simul Healthc*. 2017 Oct;12(5):332-338. doi: 10.1097/SIH.0000000000000250. PMID: 28697057.
- [4] Buchanan JA. Use of simulation technology in dental education. *J Dent Educ*. 2001 Nov;65(11):1225-31. PMID: 11765868.
- [5] Brand HS, van der Cammen CCJ, Roorda SME, Baart JA. Tooth extraction education at dental schools across Europe. *BDJ Open*. 2015 Oct 23;1:15002. doi: 10.1038/bdjopen.2015.2. PMID: 29607056; PMCID: PMC5842824.
- [6] Cowpe J, Plasschaert A, Harzer W, Vinkka-Puhakka H, Walmsley AD. Profile and competences for the graduating European dentist -

update 2009. Eur J Dent Educ. 2010 Nov;14(4):193-202. doi: 10.1111/j.1600-0579.2009.00609.x. PMID: 20946246.

- [7] Onclin P, van Minnen B, Stegenga B. Recente toename van reguliere extracties in mka-chirurgie onderzocht [Recent increase in simple extractions in OMF-surgeries in the Netherlands studied]. Ned Tijdschr Tandheelkd. 2016 Jul-Aug;123(7-8):365-72. Dutch. doi: 10.5177/ntvt.2016.07/08.16140. PMID: 27430040.
- [8] van Riet TCT, de Graaf WM, van Antwerpen R, van Frankenhuyzen J, de Lange J, Kober J. Robot Technology in Analyzing Tooth Removal - a Proof of Concept. Annu Int Conf IEEE Eng Med Biol Soc. 2020 Jul;2020:4721-4727. doi: 10.1109/EMBC44109.2020.9176405. PMID: 33019046.
- [9] G. van Rossum, Python tutorial, Technical Report CS-R9526, Centrum voor Wiskunde en Informatica (CWI), Amsterdam, May 1995."
- [10] Harris, C.R., Millman, K.J., van der Walt, S.J. et al. Array programming with NumPy. Nature 585, 357–362 (2020). DOI: 10.1038/s41586-020-2649-2.
- [11] McKinney. Data structures for statistical computing in python, , Proceedings of the 9th Python in Science Conference, Volume 445, 2010.
- [12] Hanson C, Wilkinson T, Macluskey M. Do dental undergraduates think that Thiel-embalmed cadavers are a more realistic model for teaching exodontia? Eur J Dent Educ. 2018 Feb;22(1):e14-e18. doi: 10.1111/eje.12250. Epub 2016 Dec 20. PMID: 27995728.
- [13] Keisuke Sugahara, Hiroki Bessho, Akihiro Nishiyama. The utility of custom-developed tooth extraction simulator – A comparative analysis from beginner to trainer. J Oral and Maxillofacial Surgery. 2021 Jan;33(1): doi.org/10.1016/j.ajoms.2020.08.010.