

Monitoring and Control of COVID Vaccine Storage Temperature Using IoT and Machine Learning

Royam Jain

Department of Electrical Engineering
Maulana Azad National Institute of Technology
Bhopal, India
jainroyamraj@gmail.com

Suresh Kumar Gawre

Department of Electrical Engineering
Maulana Azad National Institute of Technology
Bhopal, India
sgawre28@gmail.com

Abstract- Corona virus (COVID-19) is an infectious disease caused by the SARS-CoV-2 virus. Till now, vaccination is the most effective way of fighting this pandemic of COVID-19. This paper proposes a system which will monitor and control the temperature of the vaccine storage rooms. Here an Internet of things and Machine Learning system has been developed which will measure the real time temperature of the room and will control the temperature automatically. It will try to keep the temperature in the given region, it will predict the temperature of next twenty minutes with the help of Machine learning algorithm-linear regression, it will watch for an anomaly using Z-score analysis, it will also watch if the temperature crosses upper or lower threshold. If any of the above abnormality is detected, we will get notified online through a message, the system will maintain the temperature and the workers will also get alarmed by a led and a buzzer which will work different for each significant case.

Keywords- Internet of things, Machine Learning, COVID-19, Transmitter/Receiver, Pulse Width Modulation, Virtual Machine, Universal Asynchronous Receiver/Transmitter.

I. INTRODUCTION

Coronavirus (SARS-CoV2) originated from Wuhan, China. It spread rapidly across the world resulting in death of millions and destroying economy of most of the countries. But only some time ago, scientists developed vaccines as a precaution because no cure can be made for these kinds of viruses. Currently vaccination is the major medical precaution we can take. So, it is mandatory to protect these and to store them at standard temperature otherwise, the vaccines could get damaged and can cause a negative effect on the person and might even cause death. With the knowledge of the IoT [1][2] a system is created that will help us achieving that goal. Here, Arduino Uno has been used which is the brains of the hardware system, a LM 35 temperature sensor, a three led and buzzer warning system which will warn the workers working so that they themselves can take suitable actions as fast as possible, a cooling fan which will control the temperature, a Telegram messaging service which sends the message to the desired person(s) whenever required, and Bolt Wi-Fi module which is the heart of the WI-FI communication, sending and receiving data over WI-FI. A virtual Linux server on VMware using Ubuntu is used which will do all the necessary server-side work of our system. This paper contains the following sections: -Section II talks about the previous researches and work done, Section III describes the internet-based technologies which are used, Section IV includes the methodology and calculation techniques used, Section V gives the information of the hardware components used, Section VI gives the details of construction of the project and explains the working, Section VII deals with the data monitoring and analysis of the system through graphs and Section VII concludes.

II. STUDY OF RELATED WORK

IoT is a vast field of technology and when coupled with ML, it gets even bigger. When these two work together, fascinating systems can be made which comforts human work. Till date, many systems are made using these technologies to help us in this pandemic situation.

In research [3], patient's health is taken into consideration. As we know the costs of Covid19 tests are really high and unaffordable to many people. So, a IoT health monitoring cloud-based system is developed for covid patients. This system will monitor heart rate, blood oxygen level, temperature and blood pressure of patient. This system takes patient's health in concern and the fact that patient need not to go at the dispensary for doing expensive test. This system will give us the real-time details of patient's body. Hence patient's only need to concern a doctor if the data is not good.

In paper [4], respiratory disease is taken into consideration. A system is developed such that it will monitor the person's heart rate by using a pulse sensor and monitoring it through IoT and Arduino UNO. In [5], authors developed a system to measure the oxygen level of an individual. In [6], researchers have taken economy in consideration and developed an Economical Pulse Oximeter using IoT for patients.

According to the Storage Handling Toolkit of U.S. Department of Health and Services, there should be a system for monitoring and controlling the vaccine storage room temperature. So, this paper takes into consideration the fact that the vaccines also need to be monitored because they also play a vital role in fighting this pandemic. It is important that the rooms have proper storage and monitoring equipment that is set up correctly, use modern technologies and is cost effective. This system protects patients from inadvertently receiving compromised vaccine.

III. INTERNET BASED TECHNOLOGIES USED

A. Internet of Things:

The term Internet of Things was founded in 1999, first proposed by Kevin Ashton for linking objects with internet. In these past years, IoT has developed a lot helping in our lives to make it easier. It is still developing and will be of great significance in future [7]. Using IoT in this system will give a strong benefit over controlling the system [8]. The system will be fully automated. The information of system that is the temperature, is used to make predictions to have a more advanced system.

B. Cloud:

Cloud Computing refers to computing power without any direct management by user and providing on demand availability of Computing resources especially data storage and. Multiple clouds can be used for one system. Cloud has many features and services which can be used to our benefit.

Cloud can provide us with many features like server computing, storage of data (Database), huge network connectivity, deploying of web applications, security.

C. Application Programming Interface:

If we want different applications to communicate with each other, this technology comes into play. One of the many purposes of this project is to send SMS/notification whenever there is an abnormality so in this case, API service of Telegram is used. API service of Bolt Cloud is also used to deploy the code to our Wi-Fi module. Whenever there is an abnormality, Telegram can be accessed via bot and send a SMS about the status of the temperature.

D. Machine Learning:

Machine learning helps us in predicting the future. We take some data from daily routines and make predictions based on this data. Now predictions can't be 100% accurate but we can have an idea of future. But more the data, more precise prediction. Here, regression is used for predicting the temperature rise in the room. Python libraries are used for that. Machine learning is very useful and powerful technique as it predicts the future and tells us if there is going to be an abnormality or not so that prior actions can be taken accordingly to stop any kind of damage.

E. VMware:

A virtual computer system is known as a "virtual machine" (VM): It contains a container for different virtual machines in one machine. Basically, we can mimic some other operating system on our machine. If we have windows installed, we can run MacOS or Linux in the same machine using concept of Virtual Machines. Each VM is completely independent of the other machines. Here, software called VMware is used to run a Linux virtual server on pc and run the python program on it to fetch data and do the calculations on it and send the responses to WI-FI module through cloud.

F. Telegram:

Telegram is a mobile and desktop messaging app which is cloud-based with security and speed. It provides a facility for its users to create a custom bot which can be used for different purposes. Here, the messaging service of Telegram is used. A custom bot is created on it in a custom channel. The bot will send an automated message through the channel to all the people in it whenever an abnormality is triggered. Fig. 1 shows the basic infrastructure of how IoT works through the internet.

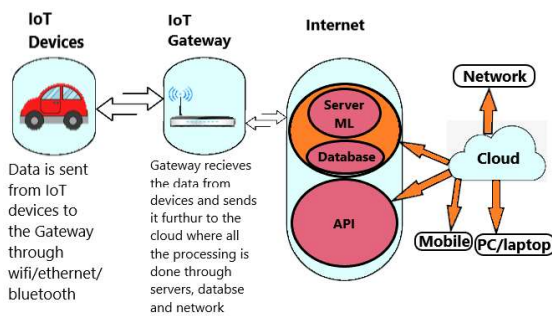

Fig. 1. IoT infrastructure over the internet

IV. PROPOSED METHODOLOGY

Let's discuss how the whole system will function. The basic idea is measuring temperature and giving alerts in case there is some abnormality. For measuring the temperature, LM 35 sensor is used. It will measure the temperature in the form of voltage and will send it to Wi-Fi module's analog pin which in turn will send it to cloud. Now the data is in the cloud, it can be accessed by using a server/virtual server. Here, VMware is used to create a virtual Linux server. From this server, the data from cloud is taken and processed. Every data is used in making predictions. All the calculations are done here, on server. There is an ML algorithm implementation in the server which is responsible for making future predictions of temperature of next 20 minutes. The equation which it uses is a simple linear equation which is

$$Y = \alpha * X + \beta \quad (1)$$

where α and β represent slope and y-intercept respectively of the algorithm and will change according to the data and Y is the predicted quantity. It is implemented by taking assistance of a python library called sklearn. This library is useful for ML implementations. An anomaly is detected when a data is not expected to be observed, or which varies significantly with our previous data. It is calculated by Z-score analysis. So, Z-score works in following way, first, mean of the data is calculated using the formula

$$mean = (\sum_{i=1}^n x_i) / n \quad (2)$$

where n is the number of observations made and x_i represents the data. Then after, using the above calculated mean, variance (var) is calculated as

$$var = \sum_{x=1}^n (x - mean)^2 \quad (3)$$

After calculating variance, the next value to calculate is z score which is calculated as

$$z = f * \sqrt{var / frame_{size}} \quad (4)$$

Here, f if the multiplying factor which decides how much of the area will be considered as normal. Increasing value of f will result in increasing the range of normality and vice versa. The frame size is the number of data to be consider while calculating the z.

After this, upper and lower bounds are calculated as

$$low_{bound} = last_{reading} - z \quad (5)$$

$$high_{bound} = last_{reading} + z \quad (6)$$

These signifies the maximum and minimum values that can be taken without detecting an anomaly. If the next observation after the last_reading crosses low or high bounds, then that will be considered as an anomaly.

After the server has done calculations and predictions are made, the outcome of calculations done is sent as suitable codes to the Wi-Fi module using Bolt cloud as the Wi-Fi module is connected to the cloud by default. Below given Table 1 maps the code with its message.

Table 1 – CODES WITH RESPECTIVE MEANING

<i>Message Code</i>	<i>Significance</i>
0	Normal
1	Predicted temperature is high
2	Predicted temperature is low
3	Anomaly is detected-high
4	Anomaly is detected-low
5	Crossed threshold-high
6	Crossed threshold-low

The appropriate code is sent to the Arduino board using the serial port UART communication through Wi-Fi module's TX/RX pins. The code in Arduino is programmed to receive codes and give responses accordingly.

V. HARDWARE IMPLEMENTATION

A. Arduino Uno:

Arduino microcontroller makes it easier to prototype electronics circuits which require perfect timing, analog readings, and writings. And can also read sensor's values quiet precisely. It can be programmed by embedded C programming. Here Arduino Uno is used which is based on ATmega328P microprocessor. It has 8 digital pins, 6 PWM pins, and 6 analog pins and TX and RX pins which are going to be used [9]. These pins use UART communication protocol through a serial port.

B. WI-FI module:

The wi-fi module going to be used is Bolt Wi-Fi module [10]. It has 5 digital pins, 1 analog pin, and TX and RX pins which will be used to communicate with Arduino Uno through serial port. This module uses ESP8266 Wi-Fi chip as its heart. This module is small and compact and uses Bolt cloud as its cloud to upload and receive data.

C. Temperature Sensor:

The most important concern in this system is measuring temperature, so LM 35 temperature sensor is used [11]. It has three pins, one for power (+), one for ground (-) and the middle one for voltage. It gives output as a number which can be converted into temperature by using a simple formula as

$$temperature = \frac{sensor_input}{10.24} \quad (7)$$

Readings will be picked up from it and will be passed to the cloud for further calculations and inspections.

D. Buzzer:

Here used is a piezo buzzer as indications or alarm to any abnormality, if found. So, by chance if the workers missed the sight of led glowing, they could hear the different sounds of buzzer and make out what is the problem. Different tones for each case have been used.

E. LED:

We all are familiar with LEDs. LEDs are also used as indicator, as in case if workers could not listen to the buzzer sound. Three LEDs are used here each for different purpose which will be discussed further.

F. BC 547:

The buzzer used here has the minimum operating voltage of 5v, but Arduino Uno digital pins gives 3.3V. So,

a BC 547 npn bipolar junction transistor has been used to trigger the buzzer whenever required. This transistor got three pins. The basic concept of this transistor is it allows current to flow through the side pins (emitter and collector) if significant (little current is required) current is given as input to the base (middle/base pin).

G. Cooling Fan:

A cooling fan is used in different systems for cooling the areas which get heated the most. For example, the processors and graphic cards in the pc require cooling due to their excessive heating. So, here it is used for cooling the rooms. The speed of the fan is adjusted by the PWM concept in Arduino board. Different speeds will be used for different scenarios which will be discussed further.

Following Table 2 gives a brief detail about the looking, name and usage of the hardware used in proposed method:

Table 2 – BRIEF TABLE OF ALL HARDWARE USED

<i>Component</i>	<i>Application</i>
Arduino Uno with ATmega 328P microcontroller	Used for controlling the hardware circuit
Bolt Wi-Fi module with ESP8266 Wi-Fi chip	Used in connecting through the internet
LM 35 temperature sensor	Used to measure the temperature of the room
Piezo buzzer (5V)	Used as an alarm for workers
LED x 3 (red, yellow, green)	Used as an indicator for workers
BC 547 transistor	Used for triggering the buzzer
Cooling fan (5V)	Used for cooling purpose

VI. CONSTRUCTION AND WORKING

A. Construction:

- 1) First connect the Wi-Fi module's analog pin A0 to the output (middle/base) pin of LM 35, the positive to the 3.3V pin, and negative to the ground pin with WI-FI module. There is a python program running on the virtual server that will fetch the data whenever required. The server notification system can be tested with a temporary program that sends notification whenever the sensor value crosses threshold. Below given Fig.2 is a screenshot of the running code of Linux server on VMware where is it visible that whenever the value crosses the predefined threshold, it sends a message to alert the person(s).

```

mro@test:~/projects$ sudo python3 main.py
50
55
56
78
96
96
94
98
450
899
Sending message to alert...
    
```

Fig. 2. Screenshot of working code on VMware

- 2) Now make the connection between WI-FI module and Arduino using the TX/RX pins. Connect TX of Arduino to RX of module and RX of Arduino to TX of module. This way they can communicate through serial port as shown in figure 3. Also, common the ground for both.
- 3) Now make connections of the Arduino board with the actuators used, that are, buzzer, BC 547 cooling fan and three LEDs. The positive pin of BC 547 is connected to the +5V pin of Arduino, signal pin is connected to the digital pin 2 of Arduino. The Buzzer positive is connected to the negative of BC 547 so that it can be triggered. And the negative of buzzer is connected to the common ground. There are three LEDs, red, yellow and green. They are connected to digital pin 13, 12 and 8 respectively of Arduino board and the ground of all three are connected to the common ground via resistor which will limit the current through LEDs. The cooling fan has three terminals, power, ground and signal. The power is connected to the +5V, the ground to the common ground and the signal to the PWM pin 6 of arduino board. The arduino and wi-fi module can be powered by same power source. Following Fig. 3 is the connection diagram of whole system. It shows how the hardware components are connected to each other and with arduino board and Wi-Fi module.

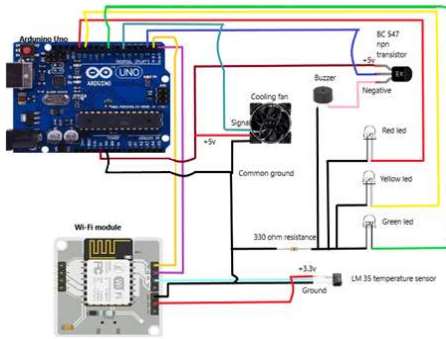

Fig. 3. Connection diagram of the proposed method

B. Working:

Below Fig. 4 is the flow diagram of how the system will function. It depicts the process of how the conditions will work throughout the system: -

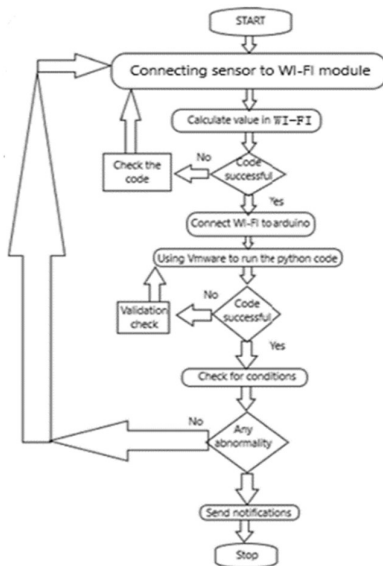

Fig. 4. Flow diagram of system

- 1) First, the LM 35 temperature sensor gives the output through the middle pin to the analog pin A0 of Wi-Fi module. It does not give the actual temperature value but what it gives is a value between 0 to 1023. This is basically the ratio of the voltage, which is applied to it, it is needed to convert it into temperature by a simple formula given in any datasheet.
- 2) Now, this data is accessed from the cloud through a server (virtual in this case). There this data is used for calculations. When the server has enough amount of data, it starts making predictions using ML and check for anomalies. A simple linear regression on the previous 50 data is applied and the temperature for next 20 minutes is predicted. Also, the Z-score analysis on the data is applied to find anomaly and the thresholds are also checked.
- 3) After calculations, the desired code number is sent from the server to the cloud to the Wi-Fi module. The Wi-Fi module then send it to the Arduino board using the TX pin and the Arduino receives it by using RX pin.
- 4) The following cases are taken into consideration and their responses are mentioned:
 - a. If temperature is normal, then buzzer will make no sound, the green led will normally blink and the fan will operate at 50% of the full speed.
 - b. If the ML algorithm predicts that the temperature will be crossed in next 20 minutes, then:
 1. If the minimum temperature is going to be crossed, then the yellow led will blink and the buzzer will buzz at an interval of 1200ms, and the fan will start to operate at 20% speed.
 2. If the maximum temperature is going to be crossed, then the yellow led will blink and the buzzer will buzz at an interval of 1200ms, and the fan will start to operate at 80% speed
 - c. If the Z-score analysis detects an anomaly, there can be two cases:
 1. If the anomaly temperature is detected high, then the red led will glow continuously, the buzzer will buzz continuously, and the fan will operate at 100% speed.
 2. If the anomaly temperature is detected low, then also the red led will glow continuously, the buzzer will buzz continuously but the fan will operate at 0% speed.
 - d. The temperature can cross the threshold in two ways:
 1. If the temperature crosses higher threshold, then the LED will blink at 200ms interval, buzzer will buzz at the same rate as led and the fan will operate at 100% speed to control the temperature.
 2. If the temperature crosses lower threshold, then the LED will blink at 200ms interval, buzzer will buzz at the same rate as led and the fan will operate at 0% speed to control the temperature.
 - e. A message will be sent on telegram by the bot created if any of the abnormality is reported.
 - f. Further actions can be taken by the workers and the individual sitting at the office/home or anywhere in the world to maintain the right temperature of the rooms so that vaccines can be kept safe.

VII. RESULTS AND ANALYSIS

Data analysis is present here with graphs:

A. Normal graph:

The following graph, Fig. 5, shows the data plotting when everything is fine, in normal conditions. It can be observed that temperature is between the thresholds and no anomaly is observed.

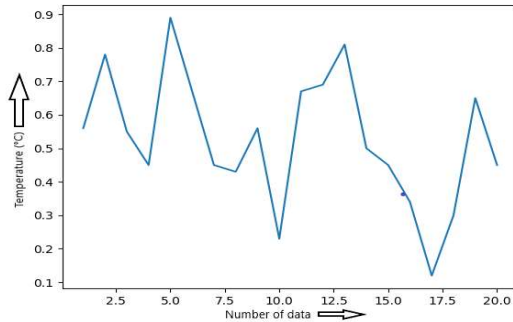

Fig. 5. Normal data plotted

B. Prediction graph:

The following graph, Fig. 6, gives the information and plot of the ML algorithm. It shows us the plot of the predicted data for the next 20 minutes. It will change every time as the data X, the slope α and the intercept β from (1) will change momentarily.

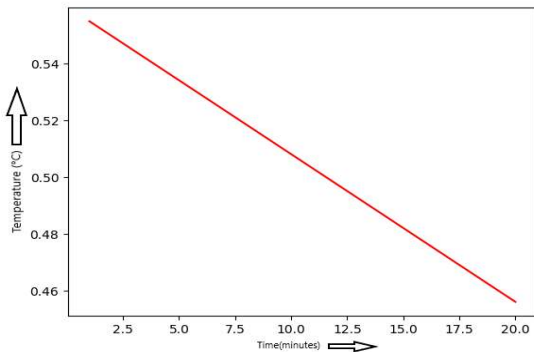

Fig. 6. Graph of predicted temperature of 20 minutes

C. Prediction V/S Normal:

The following graph, Fig. 7, gives a clear comparison between the normal(current) data and the predicted data. We can easily spot out the difference. The red line represents predicted data, and the blue line represents normal data.

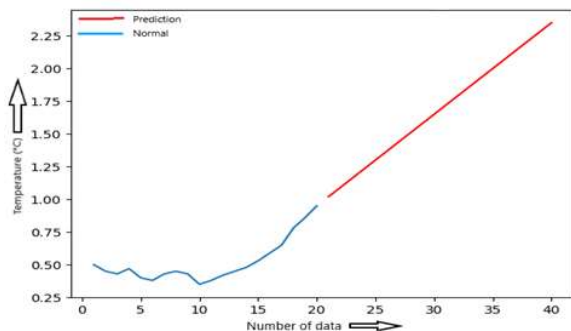

Fig. 7. Comparison of Normal data vs predicted data

D. Anomaly Detection

The following graph, Fig. 8, is shown catching an anomaly. It can be noted that a spike is shown at a point. That resembles an anomaly. A message will be sent to the dedicated people.

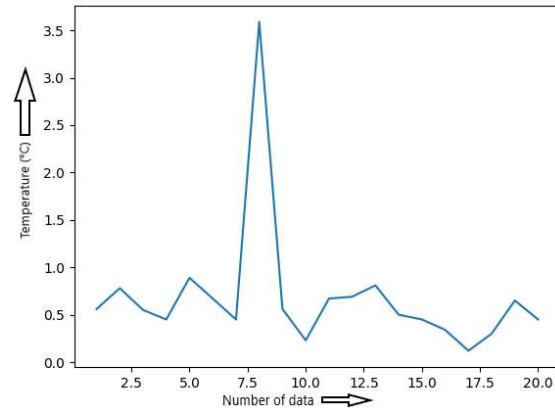

Fig. 8. A point is captured where anomaly is detected

A message will be sent over telegram by a bot created specifically for this purpose. Below is a picture, Fig. 9, which is a screenshot of a message that is received when the ML algorithm predicts the temperature is going to be increased.



Fig. 9. Temperature rise alert

Another type of message that will be received is shown in Fig. 10. Whenever an anomaly is detected, a message will be received giving the information about this abnormality.



Fig. 10. Temperature threshold alert message

VIII. CONCLUSION

This covid-19 pandemic has affected millions lives, and we need to fight. The vaccination is the most effective way to fight. This project is proposed by keeping the present requirements and needs in mind. Some issues faced were that how would workers know that the temperature is not correct because till the time they will get notified by the facility incharges, it might be late. This was resolved by adding an LED and buzzer system.

The researchers in [3][4][5][6] worked on the perspective of patient's health. In [12], authors have developed a system for vaccine storage using thermoelectric devices in the insulation of the boxes, but the system lacks the monitoring of temperature. This issue is solved here in this proposed work. This paper is focused on the vaccine's protection and importance which is equally important as

patient's health. Every storage room store a large number of vaccines from which thousands of people can be vaccinated and the vaccines provided by the government should be utilized properly. So, with this paper we proposed a system which will keep vaccines safe in these hard times.

For the future perspective, this model can be upgraded. The algorithms can be made more precise by diving deep into the ML world. The system can be totally independent if it uses solar power. Further, it can be designed in more effective way on large scale by using Raspberry Pi or other updated Embedded Systems. A custom dashboard can be made out by using web development tools like HTML, CSS, JavaScript, ReactJs, NodeJS, Django, Flask etc so we can monitor and can also control our system from anywhere in the world by using a graphical interface which is quite easier and eye-pleasing.

REFERENCES

- [1] X. Chen, L. Sun, H. Zhu, Y. Zhen and H. Chen, "Application of Internet of Things in Power-Line Monitoring," 2012 International Conference on Cyber-Enabled Distributed Computing and Knowledge Discovery, 2012, pp. 423-426, doi: 10.1109/CyberC.2012.77.
- [2] Byeongkwan Kang, Sunghoi Park, Tacklim Lee and Sehyun Park, "IoT-based monitoring system using tri-level context making model for smart home services," 2015 IEEE International Conference on Consumer Electronics (ICCE), 2015, pp. 198-199, doi: 10.1109/ICCE.2015.7066379.
- [3] T. H. Hafsiya and B. Rose, "An IoT-Cloud Based Health Monitoring Wearable Device For Covid Patients," 2021 7th International Conference on Advanced Computing and Communication Systems (ICACCS), 2021, pp. 266-269, doi: 10.1109/ICACCS51430.2021.9441717.
- [4] H. K. Pendurthi, S. S. Kanneganti, J. Godavarthi, S. Kavitha and H. S. Gokarakonda, "Heart Pulse Monitoring and Notification System using Arduino," 2021 International Conference on Artificial Intelligence and Smart Systems (ICAIS), 2021, pp. 1271-1278, doi: 10.1109/ICAIS50930.2021.9395825.
- [5] R. Saha et al., "Internet-of-Things Framework for Oxygen Saturation Monitoring in COVID-19 Environment," in IEEE Internet of Things Journal, doi: 10.1109/JIOT.2021.3098158.
- [6] R. Shinde, M. S. Alam, M. Choi and N. Kim, "Economical and Wearable Pulse Oximeter using IoT," 2021 16th International Conference on Computer Science & Education (ICCSE), 2021, pp. 168-171, doi: 10.1109/ICCSE51940.2021.9569303.
- [7] F. K. Syed, A. Paul, A. Kumar and J. Cherukuri, "Low-cost IoT+ML design for smart farming with multiple applications," 2019 10th International Conference on Computing, Communication and Networking Technologies (ICCCNT), 2019, pp. 1-5, doi: 10.1109/ICCCNT45670.2019.8944791.
- [8] S. Constantin et al., "GPRS Based System for Atmospheric Pollution Monitoring and Warning," 2006 IEEE International Conference on Automation, Quality and Testing, Robotics, 2006, pp. 193-198, doi: 10.1109/AQTR.2006.254630.
- [9] A. Mishra, D. K. Patel, T. Singh, A. Singh and S. k. gawre, "Garbage management with Smart trash using IoT," 2020 IEEE International Students' Conference on Electrical, Electronics and Computer Science (SCEECS), 2020, pp. 1-6, doi: 10.1109/SCEECS48394.2020.98.
- [10] R. K. Megalingam, G. Kishore Indukuri, D. S. Krishna Reddy, E. Dilip Vignesh and V. K. Yarasuri, "Irrigation Monitoring and Prediction System Using Machine Learning," 2020 International Conference for Emerging Technology (INCET), 2020, pp. 1-5, doi: 10.1109/INCET49848.2020.9153993.
- [11] A. Kekre and S. K. Gawre, "Solar photovoltaic remote monitoring system using IOT," 2017 International Conference on Recent Innovations in Signal processing and Embedded Systems (RISE), 2017, pp. 619-623, doi: 10.1109/RISE.2017.8378227.
- [12] J. C. Ordonez and C. Ordonez, "Thermoelectric insulation for cold temperature vaccine storage," 2021 IEEE Conference on Technologies for Sustainability (SusTech), 2021, pp. 1-5, doi: 10.1109/SusTech51236.2021.9467454.