

# A Survey of the Functional Splits Proposed for 5G Mobile Crosshaul Networks

Line M. P. Larsen<sup>1</sup>, Aleksandra Checko, and Henrik L. Christiansen<sup>2</sup>

**Abstract**—Pacing the way toward 5G has lead researchers and industry in the direction of centralized processing known from Cloud-Radio Access Networks (C-RAN). In C-RAN research, a variety of different functional splits is presented by different names and focusing on different directions. The functional split determines how many base station functions to leave locally, close to the user, with the benefit of relaxing fronthaul network bitrate and delay requirements, and how many functions to centralize with the possibility of achieving greater processing benefits. This paper presents for the first time a comprehensive overview systematizing the different work directions for both research and industry, while providing a detailed description of each functional split option and an assessment of the advantages and disadvantages. This paper gives an overview of where the most effort has been directed in terms of functional splits, and where there is room for further studies. The standardization currently taking place is also considered and mapped into the research directions. It is investigated how the fronthaul network will be affected by the choice of functional split, both in terms of bitrates and latency, and as the different functional splits provide different advantages and disadvantages, the option of flexible functional splits is also looked into.

**Index Terms**—Functional split, crosshaul, X-haul, C-RAN, fronthaul, standardization, industry, network architecture.

## I. INTRODUCTION

SINCE the first generation of mobile networks were introduced in the 1980's the popularity of mobile phones have increased to incredible heights. This has led to an industry where the network operators constantly need to renew their networks in order to keep up with the customers' demands, but still need to keep the costs down in order to offer competitive prizes. In 3G mobile networks the idea of separating the BS into two units, the Remote Radio Head (RRH) and Baseband Unit (BBU), was introduced. The RRH contained only the radio functions and was located close to the antenna in the cell site tower, where the BBU contained all baseband processing functions. Each RRH and BBU pair were connected using a new network segment called the fronthaul

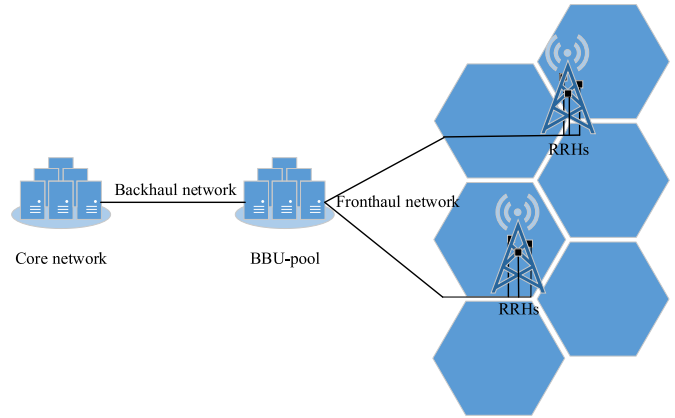

Fig. 1. Network overview of C-RAN architecture illustrating BBU-pool, RRH and the fronthaul network.

network. The fronthaul network was most often a point to point connection, and the radio signals were transmitted using either the Common Public Radio Interface (CPRI) [1], Open Base Station Architecture Initiative (OBSAI) [2] or Open Radio Interface (ORI) [3] protocol. 4G networks introduced the concept of C-RAN, where the BBUs were centralized in a strategically good location, the BBU-pool, minimizing the site rental costs and the Operation and Maintenance (OAM) efforts. The architecture is illustrated in figure 1, showing sites with RRHs connected to the BBU-pool via the fronthaul network. BBU-pool virtualization introduced the concept of shared processing, it was now possible to share the available processing resources amongst several sites and allocate extra processing efforts when needed in different areas. The network became adaptable to the non-uniform patterns of users' daily movements such as going from a residential area to a business area in the morning, and back again in the evening, referred to as the tidal-effect [4]. C-RAN selling points include:

- Exploring the so called tidal-effect: By sharing baseband resources between office and residential areas a multiplexing gain on BBUs can be achieved [4].
- Simpler implementation and easy maintenance of on-site RRHs [4].
- High speed X2 interface connecting the BBUs in the BBU-pool leading to:
  - Improved Spectral efficiency and better conditions for interference coordination techniques [5].

Manuscript received March 12, 2018; revised July 6, 2018 and August 20, 2018; accepted August 27, 2018. Date of publication October 2, 2018; date of current version February 22, 2019. This work was supported by the Eurostars "Fronthaul for C-RAN" Project funded by Innovation Fund Denmark. (Corresponding author: Line M. P. Larsen.)

L. M. P. Larsen and H. L. Christiansen are with the Department of Photonics Engineering, Technical University of Denmark, 2800 Kongens Lyngby, Denmark (e-mail: lmp@fotonik.dtu.dk; hlch@fotonik.dtu.dk).

A. Checko is with the Systems Engineering Department, MTI Radiocomp, 3400 Hillerød, Denmark (e-mail: aleksandra.checko@mtigroup.com). Digital Object Identifier 10.1109/COMST.2018.2868805

- Efficient implementation of Self-Organizing Networks (SON) [5].
- Faster handovers between cells in the same BBU-pool [6].
- Processing powers can be dynamically directed to services or areas where they are needed [7].
- Scalability to add/remove services as required [7].

These arguments imply why C-RAN technologies are important in current and future mobile networks. C-RAN is identified as one of the enablers of 5G RANs [8], [9] which is referred to as New Radio (NR) [10]. However, C-RAN has a major problem: the capacity demand on the fronthaul network is extremely high and this leaves room for improvement. Using an example from [4] considering 20 MHz LTE with 2 antennas, the bitrate is 2.5 Gbps for one RRH-BBU connection. In NR the traffic is growing to volumes where capacity demanding fronthaul bitrates are non-affordable. Therefore researchers are looking into new possibilities for lowering the bitrate on the fronthaul link, while still keeping as many benefits as possible from the traditional concept of C-RAN. One possibility is to include more functions locally at the sites and process the signal more before it is transmitted. But the question is, how many functions should be left locally? A functional split determines the amount of functions left locally at the antenna site, and the amount of functions centralized at a high processing powered datacenter. A number of different functional splits are currently being investigated to be used for NR. In NR the radio processing- and baseband- functions from the 3<sup>rd</sup> Generation Partnership Project (3GPP) protocol stack are split up into a Distributed Unit (DU) and a Centralized Unit (CU). Figure 2 illustrates the LTE protocol stack for reference, as the NR protocol stack has not yet been announced. In figure 2, the processing functions closest to the antenna ports are located in the bottom, and moving upwards the signal is going through more and more processing before it is sent into the fronthaul network. 3GPP has in [10] proposed eight functional split options including several sub-options. The red lines within figure 2 illustrate different options for functional splits, and the functions below the red line will be the functions implemented in the DU, where the functions above the red line will be performed in the CU. The functions left in the DU are very close to the users as they will be located at the antenna mast, the functions located in the CU will benefit from processing centralization, and high processing powers within a datacenter referred to as the CU-pool. The more functions located in the DU, the more processing has already been done before data is transmitted on the fronthaul network, and the lower bitrate on the fronthaul network. The fronthaul network and backhaul network form together the crosshaul [11] / xhaul [12] network, the future transport network for NR traffic.

This paper investigates the functional splits proposed by 3GPP [10] and considers the LTE network to state examples. The LTE protocol stack and the location of the functional splits are further discussed in Section II. Section III presents a survey of the functional splits proposed by 3GPP including flexible functional splits. An overview of the current standardization impacts and the different working groups and projects

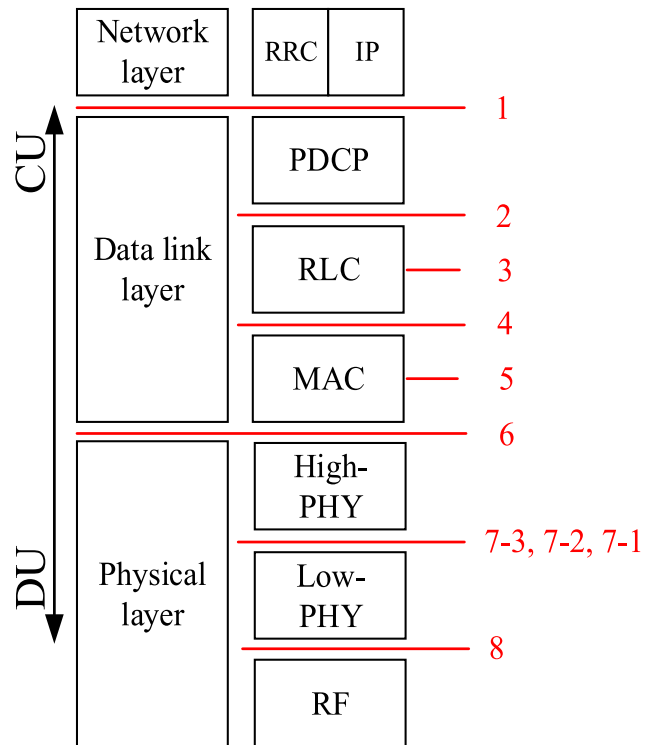

Fig. 2. The LTE protocol stack with layers and sublayers, including the numbered functional split options proposed by 3GPP [10].

currently working in this area is outlined in Section IV. In Section V is the chosen functional splits' impact on the fronthaul network considered. The different functional splits are discussed in Section VI, and the paper is concluded in Section VII.

## II. PROTOCOL STACK OVERVIEW

The description of the functional splits follows the LTE protocol stack known from the traditional BSs. The lower part of this protocol stack includes three layers; lowest is the physical layer, then follows the data link layer and on top is the network layer. The functions implemented in the different layers are illustrated in figure 2. These layers, together with the consequences of placing a functional split between specific elements, are introduced in the following sections.

### A. The Physical Layer

The physical layer handles the conversion from digital bits to outgoing radio waves in the Downlink (DL) direction and reverse for the Uplink (UL) direction. The fronthaul bitrates for the functional splits in the physical layer depends on how many users are present in the current cell, as each user occupy a certain amount of symbols in one subframe. The number of occupied symbols per second can be calculated as:

$$\#subcarriers * \#symbolsperframe * 1000 * \#antennas \quad (1)$$

The functional splits in the physical layer have the centralization benefits that features such as carrier aggregation,

Multiple Input Multiple Output (MIMO) and Coordinated Multipoint (CoMP) are efficiently supported [13]. CoMP has been seen as one of the important 5G technology candidates to improve system performance. CoMP can be divided into two classes: Medium Access Control (MAC) layer coordination and physical layer coordination. Joint reception (JR) and joint transmission (JT) are the physical layer coordinated technologies [12]. The functional splits in the physical layer require coordination from higher layers and therefore the latency requirements are very strict [13]. According to [14], the Hybrid ARQ (HARQ) process located in the MAC, requires a round trip time of 5 ms, this corresponds to a maximum 40 km fiber distance between the CU and DU [15]. Reference [16] lists a set of 3GPP timing requirements, where the requirements for frames and subframes in the physical layer are fixed in the range of ms. Reference [7] describes the one way latencies, which are described as ideal or in worst case near ideal in the physical layer splits. All split options in the physical layer are robust over non-ideal transmission conditions and during mobility, because the Automatic Repeat Request (ARQ) is centralized in the CU [10].

Figure 3 illustrates the physical layer and all the processes located within it in relation to the LTE protocol stack. At left is the LTE protocol stack illustrated and shows the focused area marked in blue. The figure illustrates the exact location of the functional splits in the physical layer from [10]. The figure is read as; the location of each functional split from 3GPP is marked by a red line and a red numbering. Split option 8 is the one with fewest functions implemented in the DU, and this split is found in the bottom of the figure right after the RF block. The figure illustrates very comprehensively all functions within the physical layer in the DL direction and further also, marked by arrows, the data that is transmitted between each function, i.e., when placing a random functional split in the figure, one can read what datatype will be transmitted on the fronthaul link. On top is the link to the MAC in the data link layer where transport blocks are transmitted between the physical layer and the data link layer.

As can be seen in figure 3: The functions in the physical layer block will transform the transport blocks received from the MAC layer into IQ symbols ready for the RF block. In this process, a Cyclic Redundancy Check (CRC) code is attached to each frame. The transport blocks are encoded and segmented into block segments, sending coded blocks through rate matching. The resulting code words are then scrambled, inverting the coded bits in each code word [17]. Then the coded bits are modulated into symbols, and the signal gets reduced depending on the order of modulation, determining how many bits are mapped to each symbol. In the layer mapper the symbols created in the modulation are mapped into one or several transmission layers [17]. Then the symbols on each layer are precoded for transmission on the antenna ports [17]. In the resource element mapper the symbols are converted into subcarriers by mapping the symbols to resource elements [17]. The next process handles the beamforming and port expansion. Then the subcarriers go through the inverse Fast Fourier Transform (iFFT) where they are converted from the frequency

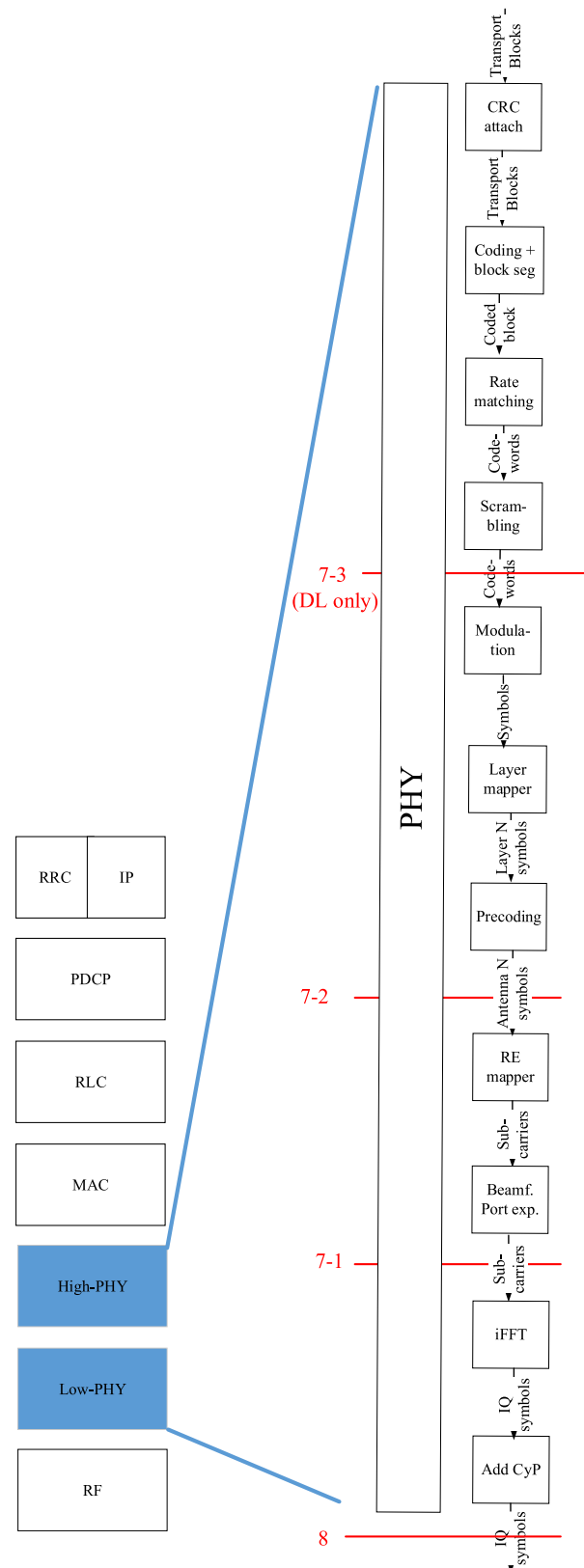

Fig. 3. Functional splits in the Physical layer illustrating the exact location of the functional splits proposed by 3GPP [10] marked by red lines.

domain into IQ symbols in the time domain. At last the Cyclic Prefix (CyP) is added to distinguish the frames from another.

**B. The Data Link Layer**

The data link layer is divided into three sublayers: Packet Data Convergence Protocol (PDCP), Radio Link Control (RLC) and Media Access Control (MAC). The Data Link layer receives, in the DL direction, radio bearers from the network layer and transmits transport blocks to the physical layer. In the PDCP there is one PDCP entity per radio bearer received. In the RLC there is one RLC entity per radio bearer received. In the MAC, the data from different radio bearers is multiplexed therefore there is only one MAC entity assigned per user [18]. Reference [16] lists a set of 3GPP timing requirements, where the requirements for the MAC is within the range of ms and the RLC processes are within the range of hundreds of ms. The PDCP timer is infinite.

The MAC performs multiplexing of RLC data from logical channels into transport blocks to be sent to the physical layer and scheduling [5]. The MAC scheduler is responsible for routing data in the network. The MAC scheduler must execute a certain set of actions every Transmission Time Interval (TTI), this requires very low latency and execution jitter [19]. The MAC instructs the RLC in the size of packets it shall receive and thereby assuring a specific Quality of Service (QoS) for each radio bearer [18]. The MAC handles the scheduling of the available resources, in [20] it is stated that including the MAC in the CU-pool can limit the performance of CoMP functions. CoMP has been viewed as one of the important 5G technology candidates to improve system performance, which can be divided into two classes: MAC coordination and physical layer coordination. Collaborative schedule (CS) is one of the MAC coordinated mechanisms [12]. The HARQ process and other timing critical functions are located in the lower MAC, therefore the splits from 1 to 5 have relaxed latency requirements on the fronthaul link, where splits 6 to 8 have very strict fronthaul latency requirements. According to [5] then having the MAC centralized in the CU-pool will enable LTE in unlicensed bands.

The RLC communicates with the PDCP through a service access point, and with the MAC via logical channels [18]. The RLC reformats Protocol Data Units (PDUs) received from the PDCP into sizes indicated by the MAC, and reorders the PDUs if they are received out of sequence [18]. The RLC is also responsible for ARQ retransmissions using protocols that makes the transmission more robust [21].

The PDCP is responsible for header compression, security functions including ciphering and verification, handovers, discard of user plane data due to timeout [18]. According to [5] having the PDCP centralized in the CU-pool will configure the 5G enabler of multiple Radio Access Technologies (RATs) being integrated.

Figure 4 illustrates the Data Link Layer and all the processes located within it in relation to the LTE protocol stack. At left is the LTE protocol stack illustrated and shows the focused area marked in blue. In the bottom of the figure transport blocks goes out from the MAC to the physical layer. And in the top comes in PDCP Service Data Units (SDUs) from the RRC in the network layer. The figure illustrates the exact location of the functional splits 1 to 6 from [10]. Like figure 3,

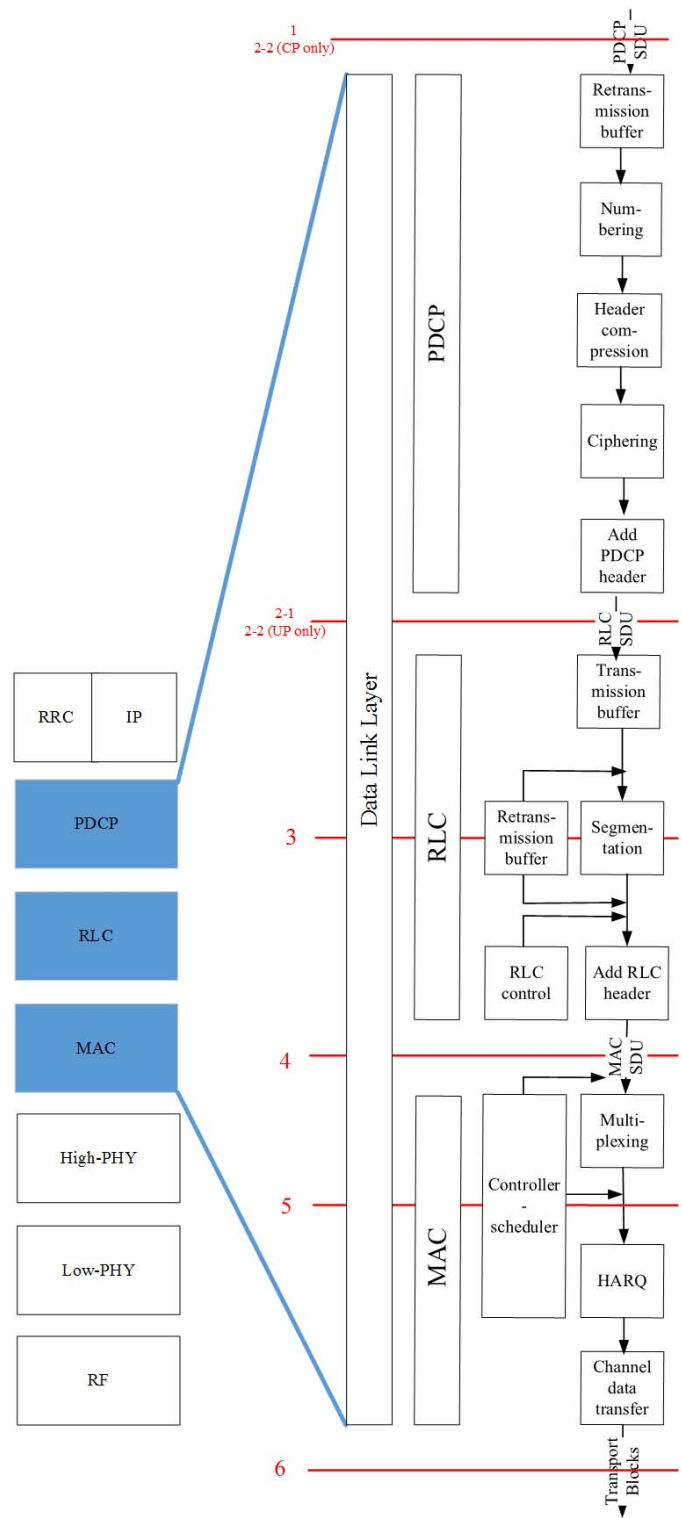

Fig. 4. Functional splits in the Data Link layer illustrating the exact location of the functional splits proposed by 3GPP [10] marked by red lines. Split 2-2 is a special case having one split for the Control Plane (CP) and another one for the User Plane (UP).

figure 4 is read as; the location of each functional split from 3GPP are marked by a red line and a red numbering to the left. Functions on top of each split are those centralized in the CU and functions below each split are those handled in the DU.

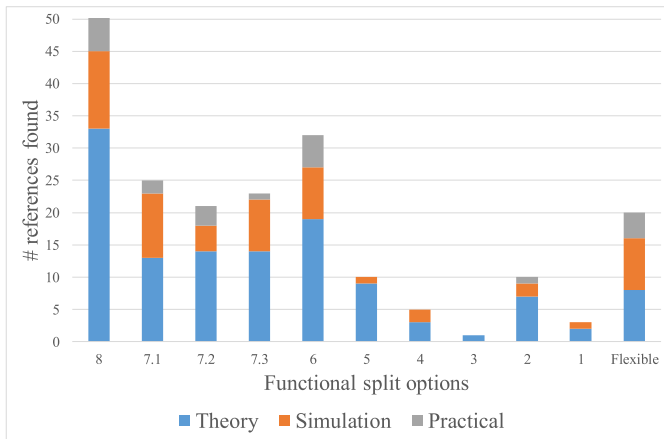

Fig. 5. Overview of the number of references in the survey, divided into theoretical papers, simulations and practical “real-life” measurements for each functional split.

### C. The Network Layer

The network layer handles data from both the Control Plane (CP) and the User Plane (UP). In the CP of the LTE protocol stack, is the Radio Resource Control (RRC) located in the network layer. In the UP, the IP protocol is used. The RRC and the network layer are connected to the datalink layer using radio bearers [22]. The RRC protocol supports a number of functions such as system information, connection control, measurement configuration and inter-RAT mobility [22]. Reference [16] lists a set of 3GPP timing requirements, where the requirements for the RRC is within the range of seconds.

## III. FUNCTIONAL SPLITS SURVEY

The possibility of splitting up the BS functions in other ways than the traditional RRH-BBU split has been investigated in several papers. The majority of existing papers focuses only on one or a few functional splits, where this paper will aim to establish an overview on all the different options that are currently considered, including flexible functional splits. This section provides an overview of the different functional splits and correlate them with the literature found in each area. Figure 5 presents an overview of the references in this survey illustrated by the amount of references presented for each functional split, divided into theory, simulation and practical work. The figure clearly states, how most of the work that has been done, has been within the splits in the physical layer, splits 6 to 8. Many papers concerning simulations of the splits 6 to 8 exists, but there appears to be an uninvestigated hole in terms of simulations of the lower numbered splits. Practical experiments have, as far as this survey shows, mostly been conducted on the splits from 6 to 8 and the flexible functional splits. This shows a huge gap in the literature as practical experiments are an important part of the development process.

Figure 6 shows the DL and UL fronthaul bitrates for the different functional splits when operating with a 20 MHz LTE carrier using 2 DL antennas and 64 Quadrature Amplitude

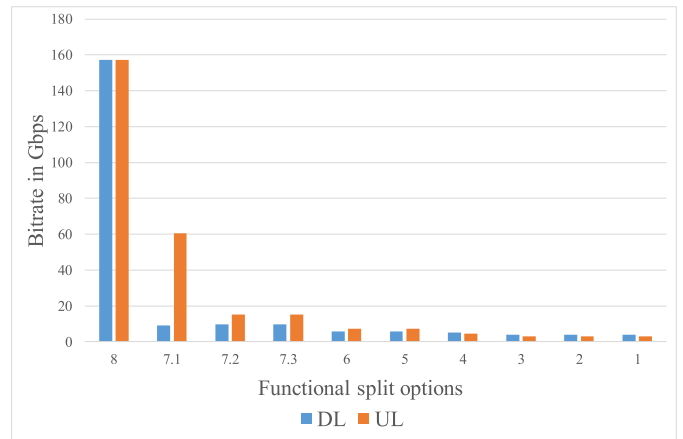

Fig. 6. Fronthaul bitrates, as per 3GPP [9] UL and DL for each functional split.

Modulation (QAM). The figure shows a full load of the entire carrier, which will always be in use for splits 8 and 7-1, but for splits 1 to 7-2 this is just the highest possible peak on the fronthaul link, as the bitrate will vary with the user load.

### A. Method of the Survey

This survey compares all functional splits proposed in [10] introduced in order with the most simple DU first, split 8, the traditional RRH-BBU split, going downwards in the numbering ending with the most complex DU in split 1. For each split all covered references are presented in three categories: References from theoretical surveys, references from simulations and references from practical experiments. State of the art is that the concept of C-RAN have been thoroughly looked into within the recent years, especially the traditional RRH-BBU split which has been known for many years. This paper will not look into all papers presenting the traditional RRH-BBU split, but present a few examples as comprehensive surveys already exists in this area.

The different functional splits will be compared in several ways. First of all it is evaluated which functions are local in the DU and which are centralized in the CU, and what each of the exact separations means for the behavior and use of the network. It is also considered how the performed simulations and practical measurements have contributed to the theory. Each split is also presented in terms of advantages, disadvantages and use cases. Finally a method for calculating the bitrate on the fronthaul link is included in the comparison. The method included follows the one proposed by 3GPP in [23], further options for bitrate calculations on the fronthaul link can be referred to [7].

To be able to calculate the bitrate on the fronthaul link, a few terms and their acronyms needs to be specified. The sample rate (SR) describing the number of samples per second, the bitwidth (BTW) which is the number of I and Q bits, the number of antenna ports (AP) defining how many antennas are connected to the DU, the number of subcarriers (SC), the number of symbols (SY), the number of layers (LA), the number of layers for control signaling (CLA), the peak rate (PR)

TABLE I  
SPLIT OPTION 8 REFERENCES

Theoretical surveys: [4], [5], [12], [19], [24], [25], [26], [27], [28], [29], [30], [31], [32], [33], [34], [35], [36], [37], [38], [39], [40], [41], [42], [43], [44], [45], [46], [47], [48], [49], [50], [51], [52]
Simulations: [53], [54], [55], [56], [57], [58], [59], [60], [61], [62], [63], [64]
Practical experiments: [65], [66], [67], [68], [69], [70], [71], [72]

measured in Mbps, the schedule/control signaling rate (CR) measured in Mbps, the bandwidth (BW) and the bandwidth for control signals (CBW).

### B. Option 8: RF/PHY

3GPPs split option 8 is what has already been introduced as the traditional RRH-BBU split. This split has been known for several years and the literature in this area is very comprehensive. Therefore, several directions within using this split is investigated focusing on the CPRI transport interface: both the traditional CPRI transport, the option of transporting CPRI over the Ethernet network and the option of compressing the CPRI signal are considered. Below a few selected examples of references are presented, as all contributions would include the entire literature on C-RAN.

In this functional split, only the Radio Frequency (RF) sampler and the upconverter are left in the DU, resulting in a very simple DU which supports different RATs [10]. The remaining functions are centralized, meaning the largest possible amount of functions can share the processing resources. This leads to efficient support of many functions for example CoMP or mobility and efficient resource management as most of the protocol stack is centralized [10]. This option may be more robust over non-ideal transmission conditions and during mobility, because the ARQ is centralized in the CU [10]. Many of the advantages of this functional split option have already been mentioned in the introduction.

On the fronthaul link connecting the DU and CU raw IQ samples are encapsulated in a protocol and transmitted continuously establishing a point to point connection between the DU and CU. These raw IQ samples require a protocol to encapsulate them when being transmitted over the fronthaul interface, this protocol can for example be OBSAI or ORI. A widely used interface is CPRI described in [1]. Some parts of the CPRI protocol are left vendor proprietary, and this makes interoperability of equipment from different vendors challenging. CPRI is a constant bitrate fronthaul interface, based on the time division multiplexing protocol by carrying out the framing in regular intervals. This protocol is specifically designed for transport of sampled radio waveforms. Using split option 8, the bitrate on the fronthaul link is constant, very high and scales with the number of antennas, which

is not very scalable for massive MIMO scenarios. To achieve the required flexibility and cost efficiency, several different line bitrates are defined for CPRI, these are described as different options [1]. The DL fronthaul bitrate for split option 8 is defined by 3GPP in [23] as:

$$FH \text{ bitrate} = SR * BTW * AP * 5 \quad (2)$$

The UL fronthaul bitrate for split option 8 is defined by 3GPP in [23] as:

$$FH \text{ bitrate} = SR * BTW * AP * 5 \quad (3)$$

The large gap between fronthaul bitrates using different functional splits is illustrated in figure 6. For a scenario using 100 MHz bandwidth and 32 antenna ports the bitrate will be 157.3 Gbps [23] for both UL and DL.

1) *Traditional CPRI Transport*: The theoretical survey provided in [4] shows a great overview of the options for using C-RAN. The paper addresses challenges in: bandwidth, latency, jitter and cost of transport network as well as CU cooperation, interconnection, centralization and virtualization. Reference [12] considers the challenge of the fronthaul bitrate being constant and increasing by the number of antennas, and fixed CU/DU mapping. References [19] and [28] consider the latency, jitter and fronthaul capacity as challenges for split option 8, and further addresses the scalability issues for 5G. Scalability issues for 5G are also considered for split option 8 in [26]. In [25] the challenges of mobile edge computing and caching, energy-efficient designs, multi-dimensional resource management and physical layer security are highlighted. Reference [24] looks into the state of the art at the time of writing and brings a summary of the contributions from different papers. Among the other benefits mentioned, [29] does also see the generalization of platforms to not only reduce the procurement cost for operators but more importantly lay down the basis for the implementation of virtualization technology. The work in [31] shows an overview of how the signal is being transmitted on the fronthaul link when choosing different functional splits in the physical layer, and provides also related equations to calculate the bitrate on the fronthaul link.

The work in [59] concludes that for split option 8, a maximum multiplexing gain on CU resources can be achieved. However, the required fronthaul capacity is the highest. Therefore this split is vital for operators with cheap access to fronthaul network. The work in [53] proves that split option 8 has a high and constant bitrate and no packetization benefits. Simulations in [58] illustrates how split option 8 is the most energy efficient functional split and it is much more energy efficient than the traditional BS. The most energy efficient fronthaul type is Time and Wavelength Division Multiplexed Passive Optical Network (TWDM-PON). Reference [62] investigates the fronthaul behavior using a game based model and shows how this leads to higher efficiency in different deployment scenarios. Simulations in [55] and [73] confirms how large amount of bandwidth can be saved when moving to other functional splits than option 8. Simulations in [63] uses a fronthaul frame aggregation strategy to improve the

packet transmission efficiency, while keeping the average fronthaul queueing delay and jitter constant, when multiplexing fronthaul and backhaul traffic.

Practical experiments in [66] demonstrates C-RAN's facilitation of CoMP implementation with 50%–100% UL CoMP gain observed in field trials. Reference [67] considers Time Division Multiplexed Passive Optical Network (TDM-PON) as transport for constant bitrate traffic, and shows that TDM-PONs can achieve a latency less than 250  $\mu$ s. Reference [68] presents digital signal processing techniques for channel aggregation and de-aggregation, frequency-domain windowing, adjacent channel leak age ratio reduction, and synchronous transmission of both the IQ waveforms of wireless signals and the control words. They demonstrate transmission of 48 20-MHz LTE signals with a bitrate of 59 Gbps, achieving a low round-trip digital signal processing latency of less than 2  $\mu$ s. Reference [72] proposes a two level modulation scheme and demonstrates the concept by transmitting a wireless signal with 2.18 Gbps payload and 3.61 Mbps control signal.

2) *CPRI Over Ethernet*: Another solution for split option 8 is to transport the CPRI interface over Ethernet. This is a cost sensitive solution where already existing Ethernet networks can be used to transport the CPRI protocols [65] and already deployed CPRI DUs can be reused too. But as the CPRI requirements in terms of delay and jitter are very strict; maximum 100  $\mu$ s delay [65] and 65 ns jitter [65], it assigns very large restrictions to the Ethernet network when transmitting the time-sensitive IQ data. CPRI over Ethernet requires a mapping between the CPRI and Ethernet frames, where the CPRI frame is encapsulated in the Ethernet frame. The encapsulation delay depends on the size of the Ethernet frame, and what CPRI option is used. The higher CPRI option used the lower encapsulation delay [65]. CPRI over Ethernet can be implemented by using a split 8 DU and then use a CPRI/CPRI over Ethernet gateway where the CPRI packets are encapsulated in Ethernet frames. The CPRI protocol can then be transported over the Ethernet network. CPRI is a very time sensitive protocol and this can cause troubles when transmitting over a packet switched network such as Ethernet. Therefore the Ethernet network requires carrier grade management to be able to transmit the CPRI protocol.

Simulations in [54] show how Ethernet networks with or without frame preemption, regardless of being shared or dedicated to CPRI traffic, cannot meet the CPRI jitter requirement of 8.138 ns. These simulations also show that Ethernet with the enhancement of scheduled traffic in conjunction with a well-defined scheduling algorithm, could significantly lower or even completely remove jitter and thus meet CPRI jitter requirements. The work in [56] verifies the feasibility of using the Precision Time Protocol (PTP) for providing accurate phase and frequency synchronization.

Practical experiments in [65] show that CPRI over Ethernet encapsulation with fixed Ethernet frame size requires about tens of microseconds delay, resulting in a few kilometers multihop fronthaul. Results in [69] considering CPRI over Ethernet, show that a dynamic CPRI link bitrate reconfiguration is achieved within about 1 ms after rate reconfiguration

TABLE II  
SPLIT OPTION 8 ASSESSMENT

Advantages
The DUs are very small and cheap [24].
UL CoMP JR and DL CoMP coherent JT can be supported without performance degradation [20].
Reuse of already deployed CPRI RRHs/DUs.
High levels of centralization and coordination across the entire protocol stack [10].
Separation between RF and PHY enables isolation of the RF components from updates to PHY [10].
DUs are RAT agnostic [10].
The largest amount of processing resources centralized in the CU-pool.
Separation of RF and PHY allows operators to share RF components [10].
Disadvantages
Very high and constant bitrate on fronthaul link, scaling with the number of antennas.
Additional processing effort for CPRI compression at DU and CU [20].
High requirements to fronthaul latency [10].
Use cases
Scenarios where high capacity fibers are present and real time communication is required.
RRHs/DUs that are already deployed can be reused for instance using a CPRI over Ethernet solution or compression techniques.

triggering. If size-based encapsulation is utilized, the time to perform encapsulation varies as a function of the CPRI link bitrate, thus causing encapsulation delay jitter. If a dynamic CPRI link bitrate reconfiguration is implemented, a time-based encapsulation of CPRI in Ethernet frames is more suitable to keep the encapsulation delay constant and avoid jitter. Reference [70] demonstrates a 120 Gbps throughput over a 10 km distance using a CPRI over Ethernet real-time system.

3) *Compressed CPRI Signal*: Another solution to keep the CPRI DUs, as they might already be installed in several places, is to compress the CPRI signal. CPRI compression techniques reduces the very high bandwidth resulted by split option 8. An example of a CPRI signal compression algorithm is proposed in [74]. Various kinds of compression techniques exist such as non-linear quantization and IQ data compression with a lossless 2:1 compression ratio, single fiber bi-direction or the introduction of new transport nodes [66].

Simulations in [57] use a proposed IQ data compression technique that dynamically reduces the required optical bandwidth based on wireless resource allocation, and provides TDM-PON with statistical multiplexing gain. The feasibility of the technique was confirmed by experiments where the reduction in the average TDM-PON bandwidth was 50% using 60 mobile terminals, all of which required 0.18 Mbps bandwidth. Other simulations in [60] shows how the bitrate will dramatically decrease when using compression techniques, compared to not using compression techniques.

TABLE III  
SPLIT OPTION 7-1 REFERENCES

Theoretical surveys: [5], [12], [26], [27], [29], [30], [31], [33], [34], [38], [41], [48], [49]
Simulations: [44], [53], [55], [58], [60], [61], [75], [76], [77], [78]
Practical experiments: [79], [80]

### C. Option 7-1: Low PHY

Please note that some of the references for this section are placed here due to estimated locations of the split, where option 7-1 was found most suitable.

In this functional split, the Fast Fourier Transformation (FFT) is included locally in the DU. Due to the Fourier transformation the data to be transmitted over the fronthaul interface is represented by subcarriers. By removing the cyclic prefix and transforming the received signal to frequency-domain using the Fast Fourier Transformation (FFT), guard subcarriers can be removed in the DU. Since the number of guard subcarriers in LTE is 40% [31], the fronthaul bitrate will be decreased. In this split the fronthaul bitrate is lowered compared to option 8, but it is still constant as the resource element mapping is executed in the CU, and the resource element mapping is necessary to detect unused subcarriers, and thereby achieve a variable bitrate. Split option 7-1 supports CoMP functions without performance degradation, JR for DL and JT for UL [20]. This option may be more robust over non-ideal transmission conditions and during mobility, because the ARQ is centralized in the CU [10]. The DL fronthaul bitrate for split option 7-1 is defined by 3GPP in [23]. Here it is assumed that split 7b is equal to split option 7-1 due to the description of split 7b in [81]:

$$FH \text{ bitrate} = SC * SY * AP * BTW * 2 * 1000 + MAC \text{ info} \quad (4)$$

The UL fronthaul bitrate for split option 8 is defined by 3GPP in [23] as:

$$FH \text{ bitrate} = SC * SY * AP * BTW * 2 * 1000 + MAC \text{ info} \quad (5)$$

The large gap between fronthaul bitrates using different functional splits is illustrated in figure 6. For a scenario using 100 MHz bandwidth and 32 antenna ports the DL bitrate will be 9.2 Gbps and the UL 60.4 Gbps [23]. This option is only considered for uplink in [10].

Using this split option, the fronthaul bitrate will achieve extra overhead from synchronization and the Ethernet frame – assuming Ethernet is used as fronthaul network, all in all approximately 8% DL overhead according to [20].

The theoretical survey in [12] addresses the reliable synchronization on packetized networks, and the delay as a challenge in functional splits lower than 8. For split option 7-1 specifically a challenge in the large difference between DL and UL bandwidth is pointed out.

In [55] several functional splits within the physical layer are proposed and simulated. Simulation results illustrate that, the proposed split 7-1 brings a drop of 30% to 40% of the fronthaul bitrate compared to split option 8. Reference [60] shows how split 7-1 obtains a gain of 43.8% in terms of fronthaul link throughput reduction compared with split 8. Simulations in [76] shows very small variations in the fronthaul bitrate when one attached User Entity (UE) is offered different traffic amounts. The authors conclude that as expected, the capacity requirement is independent of the traffic generated by the UE. Moreover, the maximum one-way latency that can be tolerated along the fronthaul is about 250  $\mu$ s as specified by 3GPP. Pérez *et al.* [44] experiment with split option 7-1 in terms of efficiency, different numbers of packets per burst and delay. The authors find that the rate of convergence of the arrivals squared coefficient of variation is different depending on the packet payload size. Furthermore, when aggregating 150 flows, it can be reduced by a factor of 4 by using 3-packets bursts, instead of 12. The results from [53] show a required fronthaul bitrate of 2.15 Gbps which corresponds to maximum nine DUs supported. Reference [61] confirms that nine supported DUs are the maximum for split option 7-1.

Simulations in [58] illustrates how split option 7-1 is much more energy efficient than the traditional BS, and the most energy efficient fronthaul type is TWDM-PON. In [75] split option 7-1 has a much higher effective throughput, as perceived by users, using fiber fronthaul compared to using Microwave Radio (MWR). Reference [77] evaluates experimentally how the latency requirement of the fronthaul network connecting DU and CU is impacted by virtualizing some of the RAN functions using different virtualization methods. The obtained results show that light virtualization methods impact the fronthaul latency budget less than heavy virtualization methods do. In addition, a maximum jitter of about 40  $\mu$ s can be tolerated in the fronthaul. The simulations in [78] experiment with linear predictive coding for fronthaul compression, the authors conclude that the proposed method allows fine regulations between the achievable compression factor and the corresponding compression Signal to noise Ratio (SNR) or Error Vector Magnitude (EVM).

The work in [79] documents an early state transmission over split option 7-1. In [80] The frequency domain IQ symbols for both DOCSIS and LTE are transmitted over fiber between the DU and cable headend, where the remaining physical layer processing is conducted. It is also proposed to cache repetitive QAM symbols in the DU to reduce the fronthaul bitrate requirements and enable statistical multiplexing, leading to a decrease in fronthaul bitrates.

### D. Option 7-2: Low PHY/High PHY

Please note that some of the references for this section are placed here due to estimated locations of the split, where



TABLE IV  
SPLIT OPTION 7-1 ASSESSMENT

Advantages
The bitrate is significantly lowered compared to split option 8.
UL CoMP joint reception and DL CoMP coherent JT can be supported without performance degradation [20].
Centralized scheduling is possible [10].
Joint processing (both transmit and receive) is possible [10].
Disadvantages
High and constant load on fronthaul link.
Very high UL bandwidth [10].
Possible subframe-level timing interactions between part of PHY layer in CU and part of PHY layer in DUs [10].
Use case
Scenarios where high capacity fibers are present and real time communication is required. But in less extreme terms compared to split option 8.

TABLE V  
SPLIT OPTION 7-2 REFERENCES

Theoretical surveys: [5], [19], [25], [26], [28], [31], [32], [38], [41], [42], [43], [44], [45], [49]
Simulations: [53], [61], [75], [83]
Practical experiments: [50], [84], [85]

option 7-2 was found most suitable. The literature indicates that there are still many suggestions on where to place this split. The exact location of this split is under discussion by 3GPP in [82].

In this split, the precoding and resource element mapper are included in the DU. The fronthaul link transports subframe symbols. This gives a slightly lower bitrate on the fronthaul link but also a more complex DU and less shared processing in the CU. Starting from this split, and all splits below have a variable bitrate on the fronthaul link as the FFT and resource element mapper are included in the DU. They can therefore be transported using a proprietary transport interface. The transport interface needs to provide a certain QoS to ensure priority for time critical data, therefore solutions can be for example Provider Backbone Bridge Traffic Engineering (PBB-TE) or carrier Ethernet. Split option 7-2 supports CoMP functions without performance degradation, JR for DL and JT for UL [20]. In this split option an in-band protocol is necessary to be able to support Physical Resource Block (PRB) allocation due to the separation high in the physical layer [20]. This option may be more robust over non-ideal transmission conditions and during mobility, because the ARQ is centralized in the CU [10]. The DL fronthaul bitrate for split option 7-2 is defined by 3GPP in [23]. Here it is assumed that split

7a is equal to split option 7-2 due to the description of split 7a in [81]:

$$FH \text{ bitrate} = SC * SY * LA * BTW * 2 * 1000 + MAC \text{ info} \quad (6)$$

The UL fronthaul bitrate for split option 7-2 is defined by 3GPP in [23] as:

$$FH \text{ bitrate} = SC * SY * LA * BTW * 2 * 1000 + MAC \text{ info} \quad (7)$$

The large gap between fronthaul bitrates using different functional splits is illustrated in figure 6. For a scenario using 100 MHz bandwidth and 32 antenna ports the DL bitrate will be 9.8 Gbps and the UL 15.2 Gbps [23].

The fronthaul bitrate requirements for this split are dependent on the number of symbols transmitted, the number of quantized bits per symbol and control information necessary for further PHY processing [5]. Using this split option, the fronthaul bitrate will achieve extra overhead from scheduling control, synchronization and the Ethernet frame – assuming Ethernet is used as fronthaul network, all in all approximately 8% DL overhead according to [20]. This option is only considered for DL in [10].

The theoretical survey in [19] addresses the limitations in the lower layer splits induced by the HARQ process in the MAC layer affecting the maximum latency and thereby also the distance between CU and DU. Reference [28] states the variable fronthaul load for this functional split and a potentially relaxed synchronization as huge benefits on the other hand the latency constraints are a challenge.

Reference [53] notes based on simulations that the slot-based and subframe-based packetization intervals are not applicable for split option 7-2 as it needs more than two symbol duration just to fill the packet. Simulations in [61] considers the delay in split option 7-2 and finds the approximated optimal payload size to be 4363 bytes. Reference [75] simulates the throughput and total cost of ownership for split option 7-2 transported over a MWR fronthaul. The work in [83] evaluates the transmission of eCPRI over Ethernet. Reference [63] observes that the transmission of 20 legacy 20 MHz LTE channels using such a functional split can be realized with 40 Gbps transponders, guaranteeing 99th delay percentiles below 9  $\mu$ s.

Practical experiments in [50] obtains results in terms of throughput and delay for different flow types. The RAN equipment is comprised of a LTE small-cell where no BS functions are centralized, and two DUs connected to a CU. In general the two DUs obtain the best results in terms of delay, but the small-cell is more stable in terms of throughput. Lund [84] and Al-Obaidi [85] test and verify an implementation of split 7-2 over a 1.4 MHz channel. The authors state that including more functions in the DU, compared to split option 8, is the key-enabler for achieving variable fronthaul data rates. This ultimately enables the possibility of having a packet-based fronthaul network relying on radio over Ethernet and time sensitive networking technologies.

TABLE VI  
SPLIT OPTION 7-2 ASSESSMENT

Advantages
Variable and moderate bitrate on fronthaul link.
Possible multiplexing gain on fronthaul link.
UL CoMP JR and DL CoMP coherent JT can be supported without performance degradation [20].
Centralized scheduling is possible [10].
Joint processing (both transmit and receive) is possible [10].
Disadvantages
An In-band protocol for PRB allocation is needed [20].
Possibly subframe-level timing interactions between part of PHY layer in CU and part of PHY layer in DUs [10].
Use case
Scenarios were the simplest possible DU is wanted together with a variable bitrate on the fronthaul link.

TABLE VII  
SPLIT OPTION 7-3 REFERENCES

Theoretical surveys: [5], [12], [29], [30], [31], [32], [36], [37], [38], [44], [47], [48], [49], [86]
Simulations: [53], [58], [61], [73], [75], [87], [88], [89]
Practical experiments: [90]

### E. Option 7-3: High PHY

Please note that some of the references for this section are placed here due to estimated locations of the split, where option 7-3 was found most suitable.

In this split the scrambling, modulation and layer mapper are included in the DU, this gives a significant lower bitrate on the fronthaul link, particularly because the signal is modulated. During the modulation the bitrate is reduced because several bits (depending on the modulation order) are assigned to each symbol. Using this functional split codewords are transmitted on the fronthaul link between the DU and CU [5]. This split includes the FEC inside the CU-pool which is a benefit for the close cooperation between the FEC and the MAC. In this split option an in-band protocol is necessary to be able to support modulation, multi-antenna processing and PRB allocation due to the separation located high in the physical layer [20]. In this split, coordinated scheduling is possible but due to the potential latencies over the fronthaul network this can result in limitations to CoMP functionalities [20]. This option may be more robust over non-ideal transmission conditions and during mobility, because the ARQ is centralized in the CU [10]. The DL fronthaul bitrate for split option 7-3 is not defined in [23] and neither in [10]. However Small Cell Forum proposes an equation for the fronthaul bitrate in [7]. As the modulation is included in the DU the bitrate is expected to be lower compared to the other option 7 splits. In figure 6 the bitrate

is estimated to be the same as option 7-2. 3GPP does only consider this functional split option for DL [10], [82].

Using this split option, the fronthaul bitrate will achieve extra overhead from scheduling control, synchronization and the Ethernet frame – assuming Ethernet is used as fronthaul network, all in all approximately 10.7% DL overhead according to [20]. According to [36] there is an additional processing delay at the DU compared to split 8, this is due to the modulation being included in the DU. This processing delay is of less than a few  $\mu$ s, because the modulation delay, RF processing delay and propagation delay should be less than 5  $\mu$ s, which is the cyclic prefix of an OFDM symbol [36]. Reference [86] proposes a low latency transmission scheme to be used for split option 7-3. The evaluations confirm that the proposed scheme reduces the DU input latency by 140  $\mu$ s.

Chang *et al.* [53] analyze the multiplexing gain for different UE densities and functional splits. The multiplexing gain for split option 7-3 is found significantly improved. Reference [58] compares the power consumption for different functional splits and the power consumption for split option 7-3 is almost the same as for a normal BS.

Reference [73] simulates splits 8, 7-3 and 6 for comparison and concludes that in their conditions, split 7-3 improves the cell-edge user throughput by 116% compared with split 6 while reducing the required optical bandwidth by 92% compared with split 8. In [88] the simulations show how split option 7-3 reduces mobile fronthaul transmission bandwidth by 90% and achieves BS coordination performance with 0.5 dB SNR degradation compared to split 8. Simulation results in [89] show that split option 7-3 reduces the fronthaul bandwidth by up to 97% compared to split 8, while matching the wireless bit error rate (BER) performance of split 8 in uplink JR with only 2 dB SNR penalty.

In [61] several schemes of the packetization process are investigated, but in general split option 7-3 supports a lower number of DUs than option 6. In [75] different fronthaul options are compared, the fronthaul capacity does not increase linearly, but jumps from limited capacity with G.fast connections, to 600 Mbps with MWR, and the results for split 7-3 show how MWR gives a higher user throughput. Compared to option 6, and using MWR fronthaul then a lower throughput perceived by users, is obtained using split 7-3. Reference [87] investigates split option 7-3 as an enabler for CoMP, the simulations show that this split can greatly facilitate the implementation of UL CoMP.

Reference [90] presents a prototype of split 7-3 where the DU and CU are connected by 10 GbE optical interfaces. The experiments show that split 7-3 reduces the fronthaul optical bandwidth by over 90% compared to split 8, for both UL and DL, and in UL the SNR penalty is less than 2 dB for CoMP.

### F. Option 6: MAC-PHY

This split separates the data link layer from the physical layer. All physical processing is handled locally and the MAC scheduler is centralized. The resulting CU pooling gain is thereby only including the data link layer and network

TABLE VIII  
SPLIT OPTION 7-3 ASSESSMENT

Advantages
The close relation between the FEC and MAC layer is kept.
The signal is modulated in the DU, leading to a significant lowered bitrate on the fronthaul link.
The load on the fronthaul link is cell load dependent [20].
A pooling for the Turbo Codec is possible compared to the splits from 1 to 6 [20].
Centralized scheduling is possible [10].
JT and JR are possible [10]. With limitations according to [20].
Disadvantages
Complex DU including the local modulation.
No latency improvement for CoMP data path and CSI compared to the MAC-PHY interface [20].
An in-band protocol is necessary for Modulation, MIMO and PRB allocation [20].
Possibly subframe-level timing interactions between part of PHY layer in CU and part of PHY layer in DUs [10].
Use case
Scenarios where the simplest possible DU is wanted, a low fronthaul bitrate is required, and where the distance between DU and CU pool is less than 40 km.

TABLE IX  
SPLIT OPTION 6 REFERENCES

Theoretical surveys: [5], [12], [19], [24], [26], [27], [29], [30], [31], [32], [33], [35], [38], [41], [42], [44], [49], [50], [91]
Simulations: [53], [58], [61], [73], [75], [92], [93], [94]
Practical experiments: [46], [95], [96], [97], [98]

layer functions, which represents approximately (implementation specific) 20% of the overall baseband processing [20]. This results in no possible energy savings for the physical layer. The payload, to be transmitted over the fronthaul, using this split is transport blocks and this leads to a large reduction in the bandwidth on the fronthaul link [10]. The load on the fronthaul link is dependent on the load at the S1 interface [20].

Using this split option, the fronthaul bitrate will achieve extra overhead from scheduling control, synchronization and the Ethernet frame – assuming Ethernet is used as fronthaul network, all in all approximately 14.1% according to [20]. Compared to the overhead in the higher split options, this option has a higher scheduling control overhead. The DL fronthaul bitrate for split option 6 is defined by 3GPP in [23] as:

$$FH \text{ bitrate} = (PR + CR) * (BW/CBW) * (LA/CLA) \times (8/6) \quad (8)$$

The UL fronthaul bitrate for split option 6 is defined by 3GPP in [23] as:

$$FH \text{ bitrate} = (PR + CR) * (BW/CBW) * (LA/CLA) * (6/4) \quad (9)$$

The large gap between fronthaul bitrates using different functional splits is illustrated in figure 6. For a scenario using 100 MHz bandwidth, 8 layers and 256 QAM modulation the bitrate will be DL 5.6 Gbps and UL 7.1 Gbps [23].

Like the splits in the physical layer, this split has very strict delay requirements as the HARQ and other time critical procedures are centralized in the CU-pool. Reference [7] describes the one way latencies as ideal or in worst case near ideal in the MAC/PHY split. But possible latencies over the fronthaul result in limitations to CoMP functionalities [20]. According to [5], this split has potential challenges for 5G schedulers as fronthaul delays may reduce the benefits from shorter subframes and wider channel bandwidth. This option may be more robust over non-ideal transmission conditions and during mobility, because the ARQ is centralized in the CU [10]. In this split option an in-band protocol is necessary to be able to support modulation, multi-antenna processing and PRB allocation due to the separation of the physical layer and MAC [20]. In the case of Small Cell forum, they propose the FAPI protocol [7].

Chang *et al.* [53] aim to find a suitable packetization method for the fronthaul transport and analyzes the multiplexing gain for different UE densities and functional splits. The multiplexing gain for split option 6 is found significantly improved. Reference [61] is a continuation of the simulations in [53], where multiplexing is added. The results, comparing with results in [53] shows a significant decreased number of DUs. Reference [58] investigates the use of different fronthaul transport types in terms of capacity and energy consumption. Comparing TWDM-PON and Ethernet PON (EPON), the first one has better energy performance but also a high capacity requirement in the fronthaul. The mm-Wave fronthaul is a better solution in terms of saving fiber and flexibility of deployment but comparatively more energy consuming. Reference [75] compares different fronthaul options, the fronthaul capacity does not increase linearly, but jumps from limited capacity with G.fast connections, to 600 Mbps with MWR, and the results for split 6 show how MWR gives a higher user throughput. The authors conclude that the results advocate the need for a heterogeneous backhaul and fronthaul with variable performance and cost to cater for different small cell needs. Besides, a fronthaul solution that is shared among small cells, such as point-to-multipoint MWR, becomes advantageous in deployments with high numbers of DU with diverse peak hour traffic distribution. Reference [73] simulates splits 8, 7-3 and 6 for comparison and split 6 shows lower performance in terms of cell-edge user throughput and average cell throughput. At the same time, split 6 shows the lowest average optical bandwidth.

The simulations in [92] focus on the UDP based data flow, as previous experiments by the authors denoted that this protocol achieves better performance in such splits. The authors

TABLE X  
SPLIT OPTION 6 ASSESSMENT

Advantages
Low and cell load dependent bitrate on the fronthaul link.
JT is possible [10].
Centralized scheduling is possible [10].
Layers from MAC and above will benefit from enhanced processing in the CU-pool [10].
Disadvantages
Close relation between FEC and MAC, they are separated in this split
Potential issues in 5G due to fronthaul delay impacting the abilities of shorter subframes [5].
Baseband pooling is only possible for L2/L3, which represents around 20% of the overall baseband processing need [20].
Additional latencies for data paths and CSI feedback information over fronthaul [20].
An In- band protocol needed for modulation, multi-antenna processing and PRB allocation [20].
Use case
Scenarios where the distance between CU and DU is lower than 40 km and only centralized scheduling is wanted.

observe a bottleneck of the backhaul link around a 1500 bits transport block size, when using a 5 MHz channel, and around 2000 bits for 10 MHz channels. Throughput achieved by the LTE UE is around 14 Mbps, whereas in the non-split case it is over 30 Mbps. For both cases 5 and 10 MHz it is observed that the backhaul network reaches its capacity for the modulation and coding scheme indexes over 14. From that point, the achieved throughput is less incremental, compared to a traditional BS. Reference [93] simulates split 6 with an Ethernet fronthaul connection, results shows the required fronthaul capacity is less than 10 Gbps when the wireless system bandwidth is 600 Mbps for 16 streams per DU, and it is possible to configure the fronthaul with commonly available Ethernet ports due to the statistical multiplexing effect. Reference [94] shows large overhead in the MAC for both CP and UP.

The experiments in [97] use split option 6 and transport the data over an Ethernet fronthaul link, the authors state that significant reductions in the fronthaul bitrate are obtained compared to split 8. Reference [46] presents some preliminary experiments using this functional split. The experiments show that such a split is feasible over Ethernet and has the advantage of not being directly affected by some of the 5G technologies such as massive MIMO. In [95] the fronthaul processing delay and the influence by different fronthaul flows are investigated and the necessity of a time-aware design is confirmed. Reference [96] confirms that mmW transport can meet the stringent latency requirements of less than 250  $\mu$ s for split option 6. Reference [98] presents for the first time a characterization of contention and priority based scheduling effects in an evolved Ethernet fronthaul obtained in a testbed.

TABLE XI  
SPLIT OPTION 5 REFERENCES

Theoretical surveys: [5], [12], [24], [27], [28], [29], [42], [43], [45]
Simulations: [99]
Practical experiments: None

### G. Option 5: Intra MAC

In this split an overall scheduler is centralized in the CU, and a MAC sublayer is local in each DU to handle time critical processing. From this split and below, the time critical procedures in the HARQ are performed locally in the DU, and also the functions where performance is proportional to latency [10]. In split option 5, the CU-pool is communicating with the DUs through scheduling commands and HARQ reports [7]. The reduced delay requirements on the fronthaul interface ensures that the distance to the CU-pool can be longer [19]. Reference [5] argues that the latency requirements are highly dependent on the realization and interaction of the scheduling functions carried out locally and centrally. On the other hand, much of the processing has to be performed locally and this limits the benefits of shared processing. The high MAC sublayer controls the low MAC sublayers and manages Inter-Cell Interference Coordination (ICIC) [10]. On the other hand using this split might lead to fronthaul delays, due to the centralized scheduling decisions and this will have limitations for the COMP scheme UL JR [10].

The DL fronthaul bitrate for split option 5 is defined by 3GPP in [23] as:

$$FH \text{ bitrate} = (PR + CR) * (BW/CBW) * (LA/CLA) * (8/6) \quad (10)$$

The UL fronthaul bitrate for split option 5 is defined by 3GPP in [23] as:

$$FH \text{ bitrate} = (PR + CR) * (BW/CBW) * (LA/CLA) * (6/4) \quad (11)$$

The large gap between fronthaul bitrates using different functional splits is illustrated in figure 6. For a scenario using 100 MHz bandwidth, 8 layers and 256 QAM modulation the bitrate will be DL 5.6 Gbps and UL 7.1 Gbps [23].

In this split the fronthaul transports pre-multiplexed higher-layer protocol datagrams, and scheduling commands [5]. Using this split the MAC scheduler in the CU can bundle multiple subframes together with low speed while at the same time the MAC scheduler and HARQ can operate at high speed [7]. This option may be more robust over non-ideal transmission conditions and during mobility, because the ARQ is centralized in the CU [10]. Reference [7] describes the one way latencies as sub ideal in the intra MAC split. The

TABLE XII  
SPLIT OPTION 5 ASSESSMENT

Advantages
The DU has only the functions requiring real-time communication included [5].
Low and cell load dependent bitrate on the fronthaul link.
Efficient interference management across multiple cells and enhanced scheduling technologies [10].
The fronthaul latency requirements depends on the realization and interaction of scheduling functions in the CU and DU.
Disadvantages
Complex interface between CU and DU [10].
Hard to define scheduling operations over CU and DU [10].
Limitations for some CoMP schemes [10].
Use case
Scenarios where as much processing in the CU-pool as possible is wanted, but the distance between the DU and CU exceeds 40 km

TABLE XIII  
SPLIT OPTION 4 REFERENCES

Theoretical surveys: [5], [50], [91]
Simulations: [21], [94]
Practical experiments: None

theoretical survey in [28] mentions the decentralized HARQ process and the relaxed latency requirements as benefits for this functional split.

In [99] results show that compared to splits 7 and 8, split 5 shows limitations in inter-cell interference reduction. But also that split 5 has benefits in processing resource utilization in the CU-pool.

#### H. Option 4: RLC/MAC

This split receives RLC Protocol Data Units (PDUs) in the DL direction and transmits MAC Service Data Units (SDUs) in the UL direction. Therefore [5] finds some constraints using this split for 5G, as subframes will be shorter in 5G and this will require more frequent decisions by the scheduler [5]. The possibility of a virtualized RLC will lead to resource sharing benefits for both storage and processor utilization [7]. The shorter subframe sizes expected in 5G will allow for more frequent decisions by the scheduler, adapting better to traffic demands or channel conditions, however this results in more frequent notifications to RLC from MAC specifying the size of the next batch of RLC PDUs [5]. This option may be more robust over non-ideal transmission conditions and during mobility, because the ARQ is centralized in the CU [10].

TABLE XIV  
SPLIT OPTION 4 ASSESSMENT

Advantages
Low and cell load dependent bitrate on the fronthaul link.
Disadvantages
The RLC and MAC are closely related [5]. In this split they are separated
No benefits for LTE [10].
Impractical in the case of shorter subframe sizes in 5G [5].
Use case
Scenarios where a local scheduler is wanted.

The DL fronthaul bitrate for split option 4 is defined by 3GPP in [23] as:

$$FH \text{ bitrate} = PR * (BW / CBW) * (LA / CLA) * (8/6) \quad (12)$$

The UL fronthaul bitrate for split option 4 is defined by 3GPP in [23] as:

$$FH \text{ bitrate} = PR * (BW / CBW) * (LA / CLA) * (6/4) \quad (13)$$

The large gap between fronthaul bitrates using different functional splits is illustrated in figure 6. For a scenario using 100 MHz bandwidth, 8 layers and 256 QAM modulation the fronthaul bitrate will be DL 5.2 Gbps and UL 4.5 Gbps [23].

In the DL direction the RLC and MAC are closely linked, as the scheduler in the MAC makes scheduling decisions every TTI and the RLC prepares the data on request [7]. Therefore in order to support this functional split either a very low latency on the fronthaul link is required or a databuffer and flow control scheme needs to be implemented at the DU [7]. Reference [7] describes the one way latencies as sub ideal in split 4. Reference [10] does not find any benefits for LTE in this split.

Simulations in [21] investigates the latencies for the RLC ARQ protocols and concludes that the delay introduced by the fronthaul network is observed to significantly degrade the throughput achieved by all ARQ protocols. The selective repeat protocol presents the highest resilience to fronthaul latency. Reference [94] states no significant overhead for the RLC.

#### I. Option 3: Intra RLC

In this split the RLC is separated into high RLC and low RLC. The low RLC is composed of segmentation functions and the high RLC is composed of ARQ and other RLC functions [10]. The UP processing of PDCP and asynchronous RLC processing takes place at the CU. All other UP functions remain in the DU including synchronous RLC network functions. Reference [91] states that this option allows multiple MAC entities to be associated with a common RLC entity. This option reduces the fronthaul latency constraints as real-time scheduling is performed locally in the DU. This option may be more robust over non-ideal transmission conditions

TABLE XV  
SPLIT OPTION 3 REFERENCES

Theoretical surveys: [91]
Simulations: None
Practical experiments: None

TABLE XVI  
SPLIT OPTION 3 ASSESSMENT

Advantages
Robust over non-ideal transmission conditions Low and cell load dependent bitrate on the fronthaul link.
Possibility of reduced processing and buffer requirements in DU [10].
Higher reliability can be achieved [10].
In option 3-2 Rx RLC is placed in the CU, there is no additional transmission delay of PDCP/RLC reestablishment procedures [10].
Option 3-2 does not induce any transport constraints [10].
Disadvantages
3-1 is more latency sensitive than 3-2 because of the ARQ location [10].
Use case
Scenarios where a low fronthaul bitrate is necessary to be transported over a less ideal fronthaul interface, which could for example be a wireless fronthaul link.

and during mobility, because the ARQ is centralized in the CU [10].

The DL fronthaul bitrate for split option 3 is defined by 3GPP in [23] as lower than option 2. In figure 6 it is estimated to be the same as for split 2.

Only very little contributions to this functional split exist, and this leaves room for further investigations.

The alternative option 3-2, have a low RLC that consists of the transmitting entities and a high RLC that consists of the receiving entities [10]. Using this option the flow control is located in the CU, this option is also insensitive to the transmission network latency between CU and DU [10]. Option 3-2 uses interface format inherited from the legacy interfaces of PDCP-RLC and MAC-RLC [10].

#### J. Option 2: RLC/PDCP

In this split the PDCP and RRC are centralized while the other functions are performed local in the DU. This split receives PDCP PDUs in the DL direction and transmits RLC SDUs in the UL direction. This split uses an already standardized interface which makes the inter-operation between elements simpler [7]. This interface is similar to the 3C architecture in LTE dual connectivity [45]. Dual connectivity transmits some of the PDCP PDUs to another cell's RLC [5]. In this split the traffic is divided into multiple flows, which can

TABLE XVII  
SPLIT OPTION 2 REFERENCES

Theoretical surveys: [5], [19], [26], [41], [45], [59], [91]
Simulations: [92], [94]
Practical experiments: [100]

be directed to various access nodes, making the split support multi-connectivity [45]. In this split all real-time aspects are located in the DU, and this makes the link requirements for this split the most relaxed [7]. This split requires a re-sequencing buffer in both the DU and CU as the correct packet order is required [7]. This split have limited potential for coordinated scheduling [5] but this can probably be compensated for using beamforming. Centralization of the PDCP offers header compression protocols which leads to a statistical multiplexing gain in the aggregation points [45]. Reference [7] describes the one way latencies, which are described as non-ideal in the PDCP/RLC split.

The DL fronthaul bitrate for split option 2 is defined by 3GPP in [23] as:

$$FH \text{ bitrate} = PR * (BW/CBW) * (LA/CLA) * (8/6) + \text{signaling} \quad (14)$$

The UL fronthaul bitrate for split option 2 is defined by 3GPP in [23] as:

$$FH \text{ bitrate} = PR * (BW/CBW) * (LA/CLA) * (6/4) + \text{signaling} \quad (15)$$

The large gap between fronthaul bitrates using different functional splits is illustrated in figure 6. For a scenario using 100 MHz bandwidth, 8 layers and 256 QAM modulation the fronthaul bitrate will be DL 4 Gbps and UL 3 Gbps [23].

Dötsch *et al.* [41] state that split option 2 only has a marginal difference to a fully integrated evolved NodeB (eNB), since only PDCP and RRC are moved into the CU. Reference [59] concludes the same, that only a marginal multiplexing gain will be obtained in the CU-pool. The theoretical survey in [19] addresses a tradeoff for the functional splits where the HARQ loop is terminated at the cell site, it is possible to achieve larger-scale centralization; however, since a significant portion of baseband functionality is left at the cell sites in these splits, the potential benefits of C-RAN such as lower cost and higher pooling gains are reduced as well. In [5] advantages of split option 2 include centralized over-the-air encryption and greater potential for coordination of mobility and handover procedures. Challenges considered in this work is limited potential for coordinated scheduling between multiple DUs.

Reference [92] reports on the real time processing performance of split option 2, and observes that the worst performing protocol is SCTP in this option. The results illustrate

TABLE XVIII  
SPLIT OPTION 2 ASSESSMENT

Advantages
The interface does already exist in dual connectivity [45].
Modest bandwidth and latency fronthaul requirements [5].
Centralized over-the-air encryption [5].
Great potential for coordination of mobility procedures [5].
Option 2-2 allows a separate UP and a centralized RRC/RRM [10]
Disadvantages
Limited potential for coordinated scheduling between multiple DUs [5], [59].
Option 2-2 requires coordination of security configurations between different PDCP instances [10].
Use case
Scenarios where a low fronthaul bitrate is necessary to be transported over a less ideal fronthaul interface, which could for example be a wireless fronthaul link. And where higher security and resiliency is obtained by CP/UP separation.

TABLE XIX  
SPLIT OPTION 1 REFERENCES

Theoretical surveys: [45], [47]
Simulations: [94]
Practical experiments: None

that for split 2, the transport protocols can pose performance limitations, but do not break the real-time operation of the base stations. Reference [94] captures the overhead in the different layers and describes how PDCP and RLC have less contribution to the CP overhead.

Reference [100] presents a crosshaul testbed where experimental results evaluate the service setup time and the service recovery time.

The alternative option 2-2 separates the RRC and PDCP for the CP and the PDCP for the UP. For a great overview of the CP and UP functions refers to in [47, Fig. 2].

#### K. Option 1: PDCP/RRC

In this split, the entire UP is located in the DU. This gives the benefit that the user data is close to the transmission point which can be beneficial for caching [10]. According to [13] this split will not support a number of features such as those providing inter-cell coordination, therefore this split might not be beneficial for implementations where many cells are connected to a CU-pool. This interface is similar to the 1A architecture in LTE dual connectivity [45]. A benefit of centralizing the RRC is that many functions are handled locally, but the user will still benefit from faster mobility management and the operator from not needing to manage and

TABLE XX  
SPLIT OPTION 1 ASSESSMENT

Advantages
Low and cell load dependent bitrate on the fronthaul link.
Separate UP and centralized RRC/RRM [10].
May have benefits in handling edge computing or low latency use cases [10].
The user data is close to the transmission point [10].
Disadvantages
Very complex DU.
Only a few functions benefit from the shared processing powers.
Does not allow traffic aggregation from NR and E-UTRA transmission points to be centralized [10].
Use case
Scenarios where edge caching is used. And there is only a few cells in the same CU-pool. This can be a rural area.

maintain the X2 interface [7]. Having a centralized RRC gives the ability of providing network information to one or more service applications [7].

The DL fronthaul bitrate for split option 1 is defined by 3GPP in [23] as:

$$FH \text{ bitrate} = PR * (BW/CBW) * (LA/CLA) * (8/6) \quad (16)$$

The UL fronthaul bitrate for split option 1 is defined by 3GPP in [23] as:

$$FH \text{ bitrate} = PR * (BW/CBW) * (LA/CLA) * (6/4) \quad (17)$$

The large gap between fronthaul bitrates using different functional splits is illustrated in figure 6. For a scenario using 100 MHz bandwidth, 8 layers and 256 QAM modulation the fronthaul bitrate will be DL 4 Gbps and UL 3 Gbps [23].

This split is also referred to as the CP/UP split, as the RRC contains the CP functions, and the UP is operated from the PDCP and above. This split requires to categorize all network functions as being either part of the control plane or user plane based on functional decomposition also it can be very challenging to take apart the CP and UP due to their tight coupling [47]. In [47] a CP /UP split design concept is proposed. The conclusion is that a full CP/UP split in combination with a centralization of CP network functions in a controller according to software defined network principles seems complex to realize and has limitations in view of wide area deployment. Reference [45] describes how signaling can be coordinated smoothly using this functional split and possibilities exists for the applications to be offloaded to a mobile edge application that runs on a mobile edge host.

The simulations in [94] investigate the overhead for the different layers and show that split 1 requires low CP overhead while bringing advantages in terms of load balancing, mobility management and energy efficiency due to the possibility of virtualizing PDCP and RRC sublayer functions because of their loose latency constraints.

TABLE XXI  
FLEXIBLE SPLIT REFERENCES

Theoretical surveys: [16], [24], [45], [60], [101], [102], [103], [104]
Simulations: [50], [99], [105], [106], [107], [108], [109], [110]
Practical experiments: [111], [112], [113], [114]

#### L. Flexible Functional Splits

Recent research have looked into the opportunity of acquiring a flexible functional split. Flexible functional splitting is also described as RAN-as-a-Service (RANaaS) in which RAN functionality is flexibly centralized, based on a cloud infrastructure [45]. In the RANaaS implementation, all RAN functionalities are not fully centralized, but instead, parts of them are flexibly centralized. Consequently, RANaaS has the ability to choose an optimal operating point between the full centralization and the local execution offered by the C-RAN and conventional LTE implementations, respectively. The partial RAN functionality centralization may subsequently be offered as a service by the RANaaS platform [45]. This is executed in the following way: a BS implementation and a C-RAN implementation. In the BS implementation all functionality in the protocol stack up to admission and congestion control is locally. In the C-RAN implementation only the radio functions functionality are locally executed and the admission and congestion control, RRM, MAC, PHY and network management are executed at the DU [45]. Reference [103] proposes a software defined fronthaul for C-RAN and defines potentials in mobility, energy consumption, customization and application performance. The paper also identifies a number of challenges to be overcome: Latency, protocol, heterogeneity and determining between electrical and optical switching.

Simulations in [99] use integer linear programming to minimize the inter-cell interference and the fronthaul bandwidth utilization by dynamically selecting the appropriate functional split. The simulations confirm that processing requirements and fronthaul bandwidth requirements change substantially, depending upon the selected functional split option used. Reference [50] analyses two different algorithms for choosing the optimal functional split in comparisons of best routing and best splits. One algorithm provides a near-optimal solution which yields a performance upper bound. The other algorithm achieves the best trade-off between computational load reduction and distance to the optimal solution. The work in [107] uses data from three different operators, shows that upgrading to un-virtualized C-RAN is most often infeasible. The proposed system operates between three functional splits: 2, 6 and 7, achieves the maximum Virtualized RAN (VRAN) centralization by selecting the optimal split and routing path for each pair of DU and CU. Simulations in [108] uses virtualization to propose a hybrid allocation of resources to DUs, note that these simulations include an

extra datacenter on the edge. Numerical results show that when power consumption is more valued, as more transport bandwidth capacity is available, more functions are placed at the CU to save power. Reference [105] uses also integer linear programming to optimize the simulation and Numerical results show a compromise between energy consumption and bandwidth consumption, with the optimal placement of base-band processing functions. In [106] a graph-based framework is used to simulate the flexible functional splits, here it is observed that smaller threshold values make distributed placement prone to higher delay penalty. In contrast, the delay bounds get looser, when more functions are placed in the DU. In [109] a virtual network embedding algorithm is proposed to flexibly select the appropriate functional split for each small cell while minimizing the inter-cell interference and the fronthaul bandwidth utilization. It is suggested to consider different functional splits for day and night times.

The Network Function Virtualization (NFV) technology can be used to implement RRH upgrades for lower splits in software [36]. This solution can be an enabler for a network with flexible functional splits, where the network functions are adapted according to a certain set of requirements and enabled when required by NFV. In [115] fronthaul is identified as a major element of SDN-based mobile network architectures.

The work in [111] demonstrates an implementation of a flexible functional split for option 8 and for option 7-1. The demonstration does only consider point to point connections transmitted over an optical fiber. If more DUs had to be aggregated, then a higher delay would be expected due to queuing in a packetized network. Results show that the analog radio over fiber options has about 15% lower latency than option 7-1, and this percentage is expected to increase if an Ethernet switch was included in the demonstration. The authors found that the proposed design has the optimal performance under different requirements of 5G networks, and the optimal solution to support the stringent latency requirements of the Ultra Reliable Low Latency Communication (URLLC) 5G use case is analog radio over fiber. Reference [112] presents a prototype implementation of Next Generation Fronthaul Interface (NGFI) based C-RAN architecture that is able to perform split option 8 and 7-1 both transported over Ethernet fronthaul. The work in [113] demonstrated a crosshaul architecture which converged fronthaul and backhaul for migrating cell sites to an agile 10 Gbps WDM access, where the fronthaul interface was based on two different NGFI split options. Experiments in [114] show how a two-step recovery scheme preserve the VRAN fronthaul connectivity even when network capacity is scarce.

#### IV. WORK IN PROGRESS

Much effort are put into exploiting new directions for NR to be ready for the future mobile networks. This section provides an overview of the currently on-going research in the field. Figure 7 and 8 illustrates the exact location of the functional splits from [10] in comparison with the split locations from other standardization organizations. The figures are read as;



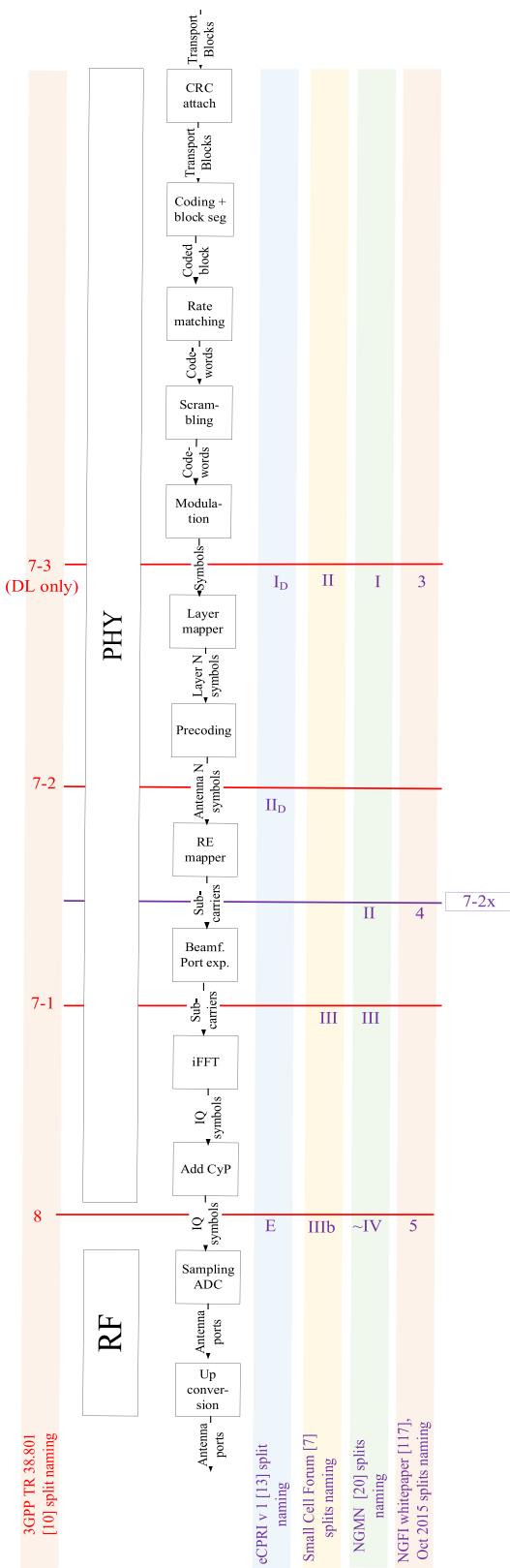

Fig. 7. Functional splits in the Physical layer illustrating the differences in the splits investigated by different standardization organizations.

the location of each functional split from 3GPP are marked by a red line and a red numbering to the left. To the right and marked by purple are options for functional splits proposed

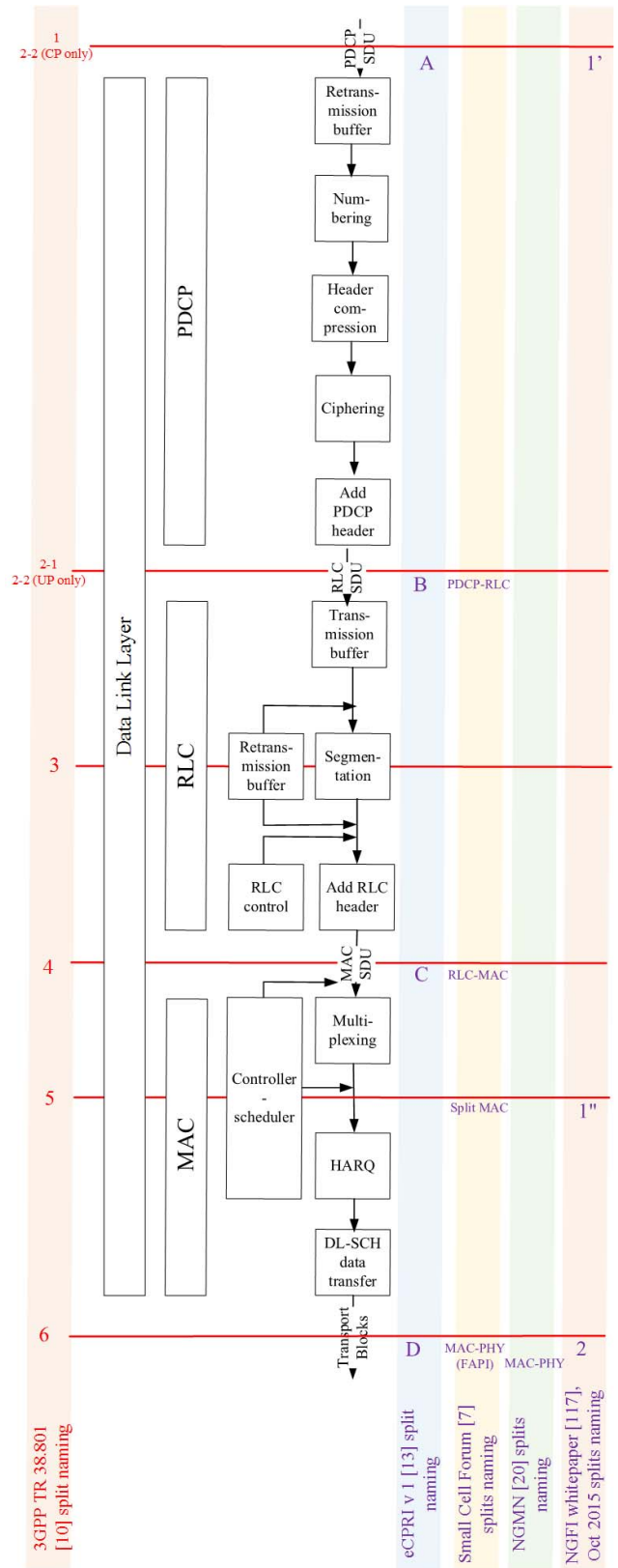

Fig. 8. Functional splits in the Data Link Layer illustrating the differences in the splits investigated by different standardization organizations.

by eCPRI, Small Cell Forum (SCF), Next Generation Mobile Networks (NGMN) and NGFI. The figures can be read in continuation of each other. The bottom of the LTE protocol

stack, the physical layer can be found in figure 7 and the data link layer is found in figure 8.

### A. Standardizational Trends

Both centralization and localization of processing functions have pros and cons, hence various organizations are looking into the standardization and analysis of functional splits. This paper uses the ongoing standardization work in 3GPP as a reference. 3GPP investigates different options for functional splits in [10] and provides eight different suggestions numbered from 1 to 8 to the functional split for use in future crosshaul networks. Option 1 has the largest amount of functions in the DU and option 8 has the least amount of functions in the DU, corresponding to the traditional RRH. Several of the options: 2, 3 and 7 consider also sub options. Release 15 [116] adopts an architecture, where gNB may consist of a gNB-CU and one or more gNB-DU(s). Currently [June 2018] Split Option 2 is chosen for high layer split, while the choice of low layer split remain for further study.

The IEEE 1914 Next Generation Fronthaul Interface (xhaul) (NGFI) Working Group [117] runs two projects supporting various functional splits: 1) IEEE 1914.1 Standard for Packet-based Fronthaul Transport Networks as well as 2) IEEE 1914.3 Standard for Radio over Ethernet Encapsulations and Mappings.

The IEEE 1914.1 standard defines reference architectures for xhaul, possible deployment scenarios covering both high- and low-layer functional splits and fronthaul requirements. It is important to note, that IEEE 1914.1 complies with 3GPP-defined partitioning schemes, but does not aim at defining them. References [118] and [119] defines the scope of the P1914.1 project to specify both an Ethernet-based architecture for the transport of mobile fronthaul traffic, including user data traffic and management and CP traffic, and requirements and definitions for fronthaul networks, including data rates, timing and synchronization, and QoS. IEEE 1914.1 defines a two-level fronthaul architecture that separates the traditional RRU to BBU connectivity in the C-RAN architecture into two tiers, via interfaces called NGFI-I and NGFI-II. NGFI-I, satisfies low layer functional split requirements connecting the RRH to the DU. NGFI-II satisfies high layer functional split requirements, connecting the DU to the CU [120], [121].

The IEEE 1914.3 standard currently supports low-layer functional splits by specifying data encapsulation into Ethernet frames. This creates a possibility to use the already established Ethernet network. The standard defines packetization of IQ samples in both the time domain and frequency domain, using mappers to transfer existing radio transport protocols over Ethernet, transferring native IQ data as well as allows for externally-defined mappers [119], [122].

The IEEE 802.1 CM draft standard looks into Time-Sensitive Networking for Fronthaul, by defining profiles to select features, options, configurations, defaults, protocols and procedures to build time sensitive networks [123]. IEEE 802.1CM enables cellular operators to use the existing Ethernet infrastructure reducing the capital and

operational expenditures by providing fronthaul implementation directions [121].

The ITU-T Technical Report on Transport network support of IMT-2020/5G [124] summarizes 3GPP 5G architecture, referring to both one tier and two tier functional splits, allowing one or two functional splits within gNB, namely to RU, DU and CU. Layer 2 (L2) non-real time and Layer 3 (L3) functions are moved from BBU to CU, Layer 1 (L1)/L2 real-time functions, as per split option 6, 7-1, 7-2 or 7-3, from BBU to DU, and the rest of L1 functions from BBU to RRU/RU. Splits where eCPRI and SCF have focus are also referred. RAN deployment scenarios cover 1) Independent RRU, CU and DU locations, 2) Co-located CU and DU, 3) RRU and DU integration as well as 4) RRU, DU and CU integration. Requirements for capacity, latency and network reach are also summarized. Expected distance between RU and DU is in range of 1-20 km, DU-CU 20-40 km, backhaul connection to core network can reach 300 km.

### B. Joint Effort

1) *Industry Alliances*: The CPRI interface in split option 8, already known from the traditional RRHs, have been described in [1]. The CPRI protocol which only considers split option 8 have been extended to eCPRI [13] which covers many more options corresponding to Options 1, 2, 4, 6, 7, 8 from [10].

The NGMN alliance focuses in [20] on the split options 6 to 8 compared to those proposed in [10]. Reference [20] presents a comprehensive work where the functional splits are investigated in terms of overhead, pros and con discussions. Recently NGMN has contributed with a new work [125] where they focus on the higher layer splits and mainly different suggestions for 3GPP's option 2, separating the CP and the UP.

SCF [7] provides a very thorough study of different options where both the fronthaul transport link requirements, the key benefits and capabilities are examined for several options. The options proposed are seen from a small cell deployment point of view though.

2) *RAN Coming From Several Vendors*: Base station functional split creates an opportunity for the CU and DU to be produced by different vendors, to enhance competitiveness among equipment and software vendors. A trend is that companies form consortia, where innovative solutions from different vendors can be integrated. The following can be referenced:

- xRAN/ORAN [126]. Founded by AT&T, Deutsche Telekom and SK Telecom in October 2016, xRAN aims at developing, standardizing and promoting a software-based, extensible Radio Access Network (xRAN). xRAN architecture decouples control- and data-plane, builds a modular base station operating on common-off-the-shelf (COTS) hardware, as well as publishes open interfaces. Currently (Jan May 2018), in xRAN there are 30 members and the number is growing. Per February 2018, xRAN is part of the Open Radio Access Network (ORAN) alliance [127]. In April 2018 xRAN Fronthaul Working Group released a "Control, User and

Synchronization Plane Specification” [128] specifying split option 7-2x for user data. This split is marked in figure 7. Management (M) plane specification is planned for Q2 2018 [129].

- Telecom Infra Project (TIP) [130] founded by, among others, Facebook, Nokia, Intel, DT and SK Telecom in February 2016 aims at disaggregating the traditional network deployment approach. Project addresses Access, Backhaul, Core and Management areas. Open RAN working group aims at developing fully programmable RAN based on General Purpose Processing Platform (GPPP). VRAN Fronthaul working group focuses on virtualized RAN with non-idea transport. Currently (Jan 2018), TIP has over 400 members.
- Central Office Re-architected as a Datacenter (CORD) [131], aims at bringing datacenter solutions to create an open reference implementation based on commodity servers and disaggregated access technologies and open soft software addressing Mobile (M-CORD), Enterprise and Residential markets. Currently (Jan 2018), M-CORD has 14 members.

### 3) Ongoing Research Projects:

- The 5G-Crosshaul is an H2020 PPP project co-funded by the European Commission. The project aims to develop a 5G integrated backhaul and fronthaul transport network enabling a flexible and software-defined reconfiguration of all networking elements in a multi-tenant and service-oriented unified management environment [132]. The proposed design is described in [133] but mostly focusing on the control infrastructure. The project ended in 2017 and has contributed to standardization along with providing several white papers and journal papers [132]. Some of the most recent literature provided by this project are: [63], [78], [96], [100], and [134].
- The 5G xhaul is an H2020 project considering a Dynamically Reconfigurable Optical-Wireless Backhaul/Fronthaul with Cognitive Control Plane for Small Cells and Cloud-RANs. 5G-xhaul proposes a converged optical and wireless network solution able to flexibly connect Small Cells to the core network [135]. The project ended in June 2018 and has contributed with a large amount of publications [135]. Some of the most recent literature provided by this project are: [28], [113], and [136].
- The 5G Programmable Infrastructure Converging disaggregated neTwork and compUte Resources (PICTURE) is a H2020 project that aims to develop and demonstrate a converged fronthaul and backhaul infrastructure integrating advanced wireless and novel optical network solutions, the project will demonstrate its services in three environments: smart city, 5G railway testbed and a stadium [137]. The project has contributed with several whitepapers and trials, the project also publishes the European 5G Annual Journal [137].
- The Fronthaul (FH) and Time Sensitive Network (TSN) technologies for Cloud Radio Access Network (C-RAN) is a project funded by Innovation Fund Denmark. The project is also known as “Fronthaul for C-RAN”. This

project looks into a fronthaul solution including the TSN technology to support Centralization of Baseband and virtualization of network functions for 5G mobile networks [138]. Some of the most recent literature provided by this project is: [139].

- The intelligent Converged network consolidating Radio and optical access aRound USer equipment (iCIR-RUS) [140] is an EU Horizon 2020 project. The project examines the advantages and challenges of bringing an Ethernet-based optical fiber fronthaul to 5G mobile networks, considering the benefits of such an architecture and its effects on performance on key 5G service aims. The project ended in 2017 [140].
- A 5G Convergent Virtualized Radio Access Network Living at the Edge: The 5G Coral project [141]. The 5G-CORAL project leverages on the pervasiveness of edge and fog computing in the RAN to create a unique opportunity for access convergence. The goal of the project is to deliver a convergent 5G multi-RAT access through an integrated virtualized edge and fog solution that is flexible, scalable, and interoperable with other domains including transport (fronthaul, backhaul), core and clouds. Some of the most recent literature provided by this project is: [142].

4) *Open Source RAN Implementations:* Building a test platform is a comprehensive project, therefore some stakeholders are joining forces in open source projects to be used for research.

- OpenAirInterface Software Alliance (OSA) is a non-profit consortium of industrial and academic contributors creating open source software and hardware development for the core network, access network and user equipment of 3GPP cellular networks [143]. The products provided are widely used for research as they are helpful in many areas, hence they can also be used for C-RAN and NR test implementations.

5) *Conclusions on Standardization Trends and Industrial Work:* As summarized in sections above, current standardization trends focus on two areas of functional split: within high layer functional split, 3GPP specifies functional split as per option 2, leaving lower layer split for further study. At the same time, industry consortia like eCPRI/IEEE/xRAN are looking into defining a lower layer split and corresponding fronthaul transport architecture. Variants of functional split option 7 and option 6 are of highest interest. Such trends are reflected in amount of publications that were published on above mentioned splits. Architectures with one or two functional splits are envisioned.

Mobile network operators are driving a market change, promoting interoperability between different equipment vendors, inviting newcomers to the market. This is reflected in growth of consortia like xRAN/ORAN, TIP and CORD.

## V. IMPACT ON FRONTHAUL NETWORK

The fronthaul network connecting the DUs and CU-pool consists of a data transmission link. On this link, high bitrates and low latency is required. The physical connections in the

fronthaul network can be implemented using a fiber connection or other wired solutions, it can be wireless or it can be a mixture of wired and wireless solutions. For a comprehensive study of the different transport options for fronthaul networks is referred to [144]. This section elaborates on how the choice of functional split will affect the fronthaul network.

### A. Fronthaul Latency

The latency in the fronthaul network is crucial to determine the size of the network. A few investigations have already been proposed in this area: 3GPP have already proposed their own requirements for one-way latency [10]. These requires max 10 ms for option 1, max 1.5-10 ms for option 2 and 3, approximate 0.1 ms for option 4, more than 0.1 ms for option 5 and max 0.25 ms for options 6 to 8 [10]. These requirements are based on support of specific features and use cases in the different options. In [7] different one-way latency requirements are considered for different split options, for option 1 and 2-1 the one-way latency requirement is 30 ms, for option 4 and 5 the one-way latency requirement is 6 ms and for option 6 to 8 the one-way latency requirement is 0.25 ms. In [41] the term “max latency” is used describing 2 ms max latency for splits 5 and 6, and 0.15 ms max latency for splits 7 and 8. Reference [107] reports on 30 ms delay for split option 2, 2 ms for option 6 and 0.25 ms delay for option 7. In [13] eCPRI defines a one-way maximum packet delay of 0.1 ms for splits 7 and 8. In [20] NGMN presents a 0.25 ms maximum fronthaul latency. Reference [76] presents a simulation considering split option 7-1, where a 10 MHz carrier has the fronthaul latency limit of 0.2 ms and a 5 MHz carrier has the fronthaul latency limit of 0.25 ms. The fronthaul latency is also considered in [115].

The distance between a DU and the CU-pool is determined by the latency. The distance between the DU and CU-pool, assuming the fronthaul is connected using fiber, can be determined by:

$$FH \text{ length} \geq (\text{Max delay} - \text{total delay}) / \text{propagation delay per km} \quad (18)$$

The max delay is depending on what application is chosen. Different applications have different latency requirements. Therefore the delay in the network, delay, must always be less than the max delay:

$$\text{Max delay} > \text{total delay} \quad (19)$$

The fiber propagation delay per km is [65]:

$$\text{Fiber propagation delay} = 10 \mu\text{s}/\text{km} \quad (20)$$

In the case of splits 6-8 the max delay will be limited by the HARQ process max Round Trip Time of 5 ms [14]. The limitation for the splits 1-5 where the HARQ process is included in the DU is more loose and depends on the network requirements.

To be able to support real-time functions, a very low level of latency is crucial for the fronthaul transport. Due to these considerations the delay needs to be calculated in three different ways for option 8, options 6-7 and options 1-5.

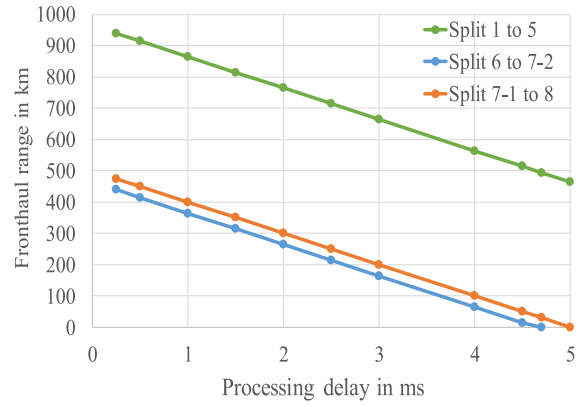

Fig. 9. Length of fronthaul depending on processing delay.

Delay budget for option 8, where the max delay is limited by the HARQ process:

$$5 \text{ ms} > 2 * \text{transmission delay} + \text{processing delay} + 2 * \text{propagation delay} \quad (21)$$

Delay budget for options 6-7, here an Ethernet fronthaul is assumed and therefore a delay for one Ethernet switch is added as  $D_{sw}$  and multiplied by the number of switches:

$$5 \text{ ms} > 2 * \text{transmission delay} + \text{processing delay} + 2 * \text{propagation delay} + D_{sw} * \#\text{switches} \quad (22)$$

Delay budget for options 1-5, after the HARQ is included in the DU, the 5 ms limitation is no longer an issue, but the network still needs to fulfill the latency requirements for a specific application:

$$\text{Max delay} > 2 * \text{transmission delay} + \text{processing delay} + 2 * \text{propagation delay} + D_{sw} * \#\text{switches} \quad (23)$$

The latency includes RF propagation time, DU processing time and CU processing time. Reference [44] describes the propagation delay for different topologies and environments. In [145] values for latency calculations are presented for a split option 8 fronthaul size calculation. For further considerations on fronthaul latency is referred to [139].

Figure 9 illustrates the length of the fronthaul as a function of the processing delay in the CU-pool. The figure clearly illustrates how splits 1 to 5 can have a much longer length of the fronthaul. the max delay considered for splits 1 to 5 in figure 9 is 10 ms. Figure 10 illustrates again the fronthaul as a function of the processing delay but here focusing on the functional splits 6 to 7-2, where the HARQ is located in the CU, and shows how the amount of switches the fronthaul data needs to be processed through impacts the length of the fronthaul network.

### B. Fronthaul Aggregation

When the data is transmitted between the CU and DU it must be assumed that several data streams will be aggregated,

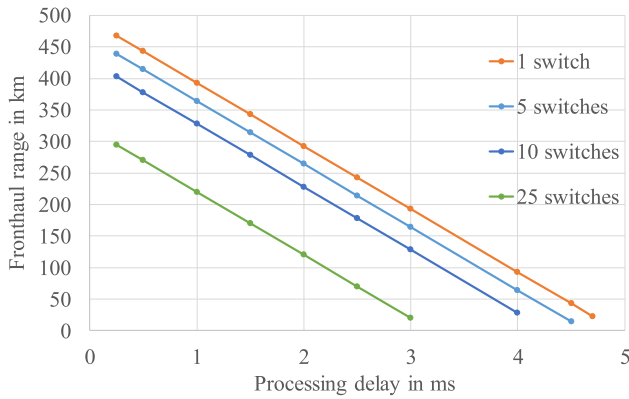

Fig. 10. Length of fronthaul depending on processing delay illustrated for splits 6 to 7-2 having the HARQ process in the CU. The figure shows how the fronthaul length also depends on how many switches the data needs to be processed through as each switch adds delay.

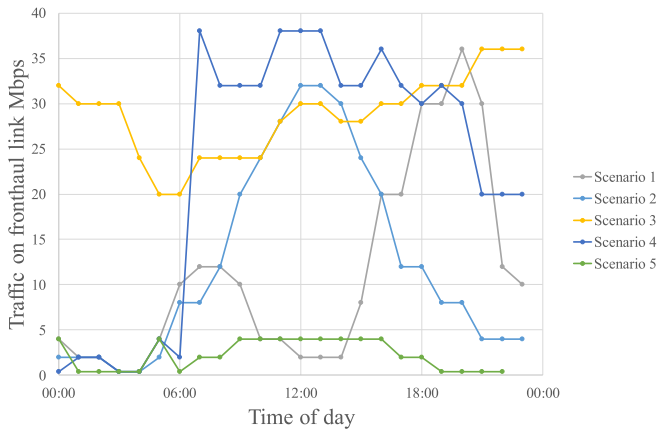

Fig. 11. Comparison of the scenarios using bitrates from 3GPP [10] functional split option 1.

there will not be point to point connections between the DU and the CU-pool. To test different aggregation situations five different scenarios were considered:

- Scenario 1: A residential area with traffic peak in the morning and a larger peak in the evening.
- Scenario 2: A business area with peak in the middle of the day.
- Scenario 3: A mid city area with high traffic all times of the day, a little less in the middle of the night.
- Scenario 4: A shopping mall with very high traffic loads during the entire day and evening, but almost none in the night.
- Scenario 5: A rural area with very low traffic during the day and almost none during the night.

All these scenarios are considered to use 20 MHz LTE with 2 downlink antennas and up to 64 QAM modulation, depending on the users' signal conditions. The scenarios are illustrated in figure 11. The aggregation of fronthaul links considers three different options. The input parameters are: The average cell traffic,  $AT$ , and the peak cell traffic,  $PT$ . then the total aggregated traffic,  $TT$ , from  $N$  cells can be calculated in the following way:

- All average:

$$TT = N * AT \quad (24)$$

item All average/Single peak:

$$TT = Max(N * AT; PT) \quad (25)$$

- All peak:

$$TT = N * PT \quad (26)$$

The bitrates used in these calculations are calculated based on a slightly modified version of the equations proposed in [7].

Two situations will be considered: The total bandwidth on the fronthaul link as the limiting factor and the number of DUs as the limiting factor. First, considering the total bandwidth as the limiting factor. Using Ethernet there will be many different options, to state an example Gb Ethernet, 10 Gb Ethernet and 100 Gb Ethernet are considered. Table XXII shows the total amount of DUs supported when using the different types of fronthaul compared to using different functional splits. The table is based on the five scenarios, therefore all numbers of DUs are a multiple of five, as they always have the same number of DUs aggregated from each scenario.

When considering the number of DUs as the limiting factor, it can be investigated how much bandwidth the aggregation of a certain number of DUs will take up. For example having three DUs from scenario 1, two from scenario 2, five from scenario 3, one from scenario 4 and four from scenario 5. Then the corresponding DL bandwidths required for the different functional splits are:

- Using split option 1 the fronthaul need to be able to carry at least 0.13 Gbps. (Method: All average)
- Using split option 6 the fronthaul need to be able to carry at least 0.17 Gbps. (Method: All average)
- Using split option 7-2 the fronthaul need to be able to carry at least 0.3 Gbps. (Method: All average)
- Using split option 7-1 the fronthaul need to be able to carry at least 138 Gbps. (No method, constant)
- Using split option 8 the fronthaul need to be able to carry at least 2360 Gbps. (No method, constant)

The numbers presented in this chapter show the very huge difference in having a constant, high bitrate on the fronthaul link and having a variable bitrate on the fronthaul link. Note that the numbers have not been added any extra capacity for dimensioning in the cases of variable bitrates. This section only compares the numbers at not the advantages obtained when choosing any of the splits.

## VI. DISCUSSION

In future 5G networks the amount of cells will increase to an extreme number. This means that with C-RAN, one CU-pool will probably be connected to hundreds or even thousands of DUs. By using the traditional RRH-BBU split for all those DUs, great advantages are obtained giving the largest amount of shared resources and very simple and scalable DUs. On the other hand, by using a lower split, fewer resources can be shared and the DU will be more complex, but the load on

TABLE XXII  
OVERVIEW OF THE MAX NUMBER OF DUS SUPPORTED BY DIFFERENT SIZES OF FRONTHAUL CAPACITY

	Option 8	Option 7-1	Option 7-2	Option 7-3	Option 6	Option 5	Option 4	Option 3	Option 2	Option 1
Gb E	0	0	0	10	20	20	20	20	20	20
10 Gb E	5	10	135	235	220	135	230	235	240	240
100 Gb E	40	100	1355	2395	2210	2330	2395	2405	2405	2410

TABLE XXIII  
COMPARISON OF THE DIFFERENT FUNCTIONAL SPLITS

	Option 8	Option 7-1	Option 7-2	Option 7-3	Option 6	Option 5	Option 4	Option 3	Option 2	Option 1
Baseline available	CPRI [1]	1914.3 [122]	eCPRI split II <sub>D</sub> [13]	eCPRI split I <sub>D</sub> [13]	eCPRI split D [13]	N/A	eCPRI split C [13]	N/A	eCPRI split B [13]	eCPRI split A [13]
Fronthaul bitrate scaling	Scales with antenna ports [10]		Scales with MIMO layers [10]							N/A
Multi cell coordination	Centralized scheduler [10]							Local scheduler [10]		

the fronthaul network will be lower and vary with the user load. This is a trade-off between localizing and centralizing the BS functions. The latter scenario will also prove more resilient compared to a traditional BS, as there will be more processing power available in the CU-pool, and thereby also backup options. The higher numbered splits have the advantages that they support advanced functions such as CoMP and they are more robust to non-ideal transport conditions. At the same time they have very strict latency requirements and a higher bitrates. The lower splits have moved almost all functions local, close to the user. This results in a high utilization of the fronthaul link, but only few resources shared in the CU-pool. In short, the higher split the more resources shared in the CU-pool and the lower split the more resources shared on the fronthaul link. But also other things need to be taken into consideration: For example, under certain circumstances, it will be more efficient to have a longer distance between the DU and CU than the 40 km limited by the HARQ process. This could be to cover a rural area or to cover a certain road by one CU-pool and benefit from fast handovers. The possibility of having multiple local schedulers as in split 1 to 4 can be beneficial when a lot of processing power is required locally.

In some areas option 8 or 7-1 will be very efficient due to the large amount of shared processing resources, but this requires a high capacity fronthaul network. If fibers have already been deployed, for example in a city area where a large amount of cells are required, the fronthaul network can be upgraded to Dense Wavelength Division Multiplexing (DWDM) which has very large capacity, but is very costly. But one can argue that shared processing has a better impact on the energy consumption compared to shared fronthaul transmission. As outlined in

Table XXIII, the fronthaul bitrate for option 7-1 and 8 scales with the number of antenna ports, where the fronthaul bitrates for the options from 2 to 7-2 scales with the number of MIMO layers. Split option 7-1 does, like option 8, not include the resource element mapper, which is necessary to detect unused subcarriers, and thereby achieve a variable bitrate. Therefore it can be discussed whether split option 7-1 obtains any benefits from being transported over Ethernet, apart from those considered for CPRI over Ethernet. It might be beneficial to transport the fronthaul data using CPRI with a lower linerate. The splits with low bitrates on the fronthaul link, particularly 1-5 will be more efficient in rural areas and areas where fibers are not available.

The functional splits options 1-4 have the entire MAC located locally at the DU. This can affect the routing decisions as the scheduler is placed locally and not centrally where it can manage the routing to several sites. This can be a problem for time critical applications, as the most optimal route might not always be chosen in those scenarios. On the other hand, these functional splits have very low bitrates on the fronthaul link.

The collection of references shows where most effort has been assigned by the researchers, which is primarily in the lower layer splits, i.e., split 6 to 8, but recent papers are focusing more on the opportunity of flexible functional splits. The standardization focus points towards the choice of one high layer functional split and one low layer functional split, which is determined by NGFI-I and NGFI-II for IEEE 1914.1 and for 3GPP has the high layer split already been determined to focus on option 2 while the low layer split remains under investigation. In the industry eCPRI provides a large variety of functional splits both covering the higher and lower layers, while NGMN focus on the lower layers in split 6 to 8

and split 2. This survey shows how more focus is required on practical work for all splits but focusing on splits 2, 6 and 7 as those are the ones the industry has highlighted. Table XXIII illustrates what baselines are available for the functional splits investigated in this survey, and shows that no baseline are yet available for split options 3 and 5.

## VII. CONCLUSION

This survey provided a comprehensive literature overview of the functional split options proposed by 3GPP [10] and showed how more focus is required on practical work for all splits, but focusing on splits 2, 6 and 7 as those are the ones the industry has highlighted. Each functional split has been discussed in a detailed description of the location and abilities. This was done to detect what is being transmitted on the fronthaul link but also which functions are located in the DU and the CU, respectively. This lead to an assessment of the advantages and disadvantages. Further an overview was provided for research directions and current literature describing each of the functional splits. The trend is that functional splits in the physical layer have been investigated the most, but in general there are not many examples of practical experiments with other functional splits than option 8. This paper has also considered the trends seen currently in the different standardization organizations and the current trends in the industry. Finally this paper has also considered the impact of the chosen functional split on the fronthaul network connecting the DU to the CU-pool both in terms of fronthaul bitrates and latency.

### LIST OF ACRONYMS

3GPP	3 <sup>rd</sup> Generation Partnership Project	GPPP	General Purpose Processing Platform
AP	Number of antenna ports	HARQ	Hybrid - ARQ
ARQ	Automatic Repeat Request	ICIC	Inter-Cell Interference Coordination
AT	Average cell traffic	iFFT	Inverse FFT
BBU	Baseband Unit	IQ	In-phase and Quadrature
BER	Bit Error Rate	JR	Joint Reception
BS	Base Station	JT	Joint Transmission
BTW	Bitwidth	L1	Layer 1 – physical layer
BW	Bandwidth	L2	Layer 2 – data link layer
CBW	Bandwidth for control signals	L3	Layer 3 – network layer
CLA	The number of layers for control signaling	LA	The number of layers
CoMP	Coordinated Multipoint	LTE	Long Term Evolution
CSI	Channel State Information	M	Management
CP	Control Plane	MAC	Media Access Control
CPRI	Schedule/control signaling rate	MIMO	Multiple Input Multiple Output
CR	Signaling Rate	MWR	Microwave Radio
C-RAN	Cloud- Radio Access Network	N	Number of cells
CRC	Cyclic Redundancy Check	NFV	Network Function Virtualization
CS	Collaborative Schedule	NGFI	Next Generation Fronthaul Interface
CU	Central unit	NGMN	Next Generation Mobile Networks
CyP	Cyclic Prefix	NR	New Radio
Dsw	Delay per switch	OBSAI	Open Base Station Architecture Initiative
DU	Distributed Unit	ORI	Open Radio Interface
DWDM	Dense Wavelength Division Multiplexing	PBB-TE	Provider Backbone Bridge Traffic Engineering
EPON	Ethernet Passive Optical Network	PDCP	Packet Data Convergence Protocol
FFT	Fast Fourier Transformation	PDU	Protocol Data Unit
		PHY	Physical (layer)
		PR	Peak rate
		PRB	Physical Resource Block
		PTP	Precision Time Protocol
		QAM	Quadrature Amplitude Modulation
		QoS	Quality of Service
		RAN	Radio Access Network
		RANAas	RAN-as-a-Service
		RAT	Radio Access Technology
		RF	Radio Frequency
		RLC	Radio Link Control
		RRC	Radio Resource Control
		RRH	Remote Radio Head
		SC	The number of subcarriers
		SCF	Small Cell Forum
		SDU	Service Data Unit
		SNR	Signal to noise Ratio
		SR	Sample rate
		SY	The number of symbols
		TDM	Time Division Multiplexing
		TDM-PON	Time Division Multiplexed Passive Optical Network
		TT	Total aggregated Traffic
		TTI	Transmission Time Interval
		TWDM-PON	Time and Wavelength Division Multiplexed Passive Optical Network
		UE	User entity
		UP	User plane
		VRAN	Virtual RAN
		WDM	Wave Division Multiplexing
		xRAN	eXtensible RAN.

## REFERENCES

- [1] *CPRI Specification V7.0 Common Public Radio Interface (CPRI); Interface Specification*, CPRI Consortium, Bengaluru, India, 2015.
- [2] *Open Base Station Architecture Initiative*. Accessed: Mar. 9, 2018. [Online]. Available: <http://www.obsai.com/>
- [3] *ETSI*. Accessed: Mar. 9, 2018. [Online]. Available: <http://www.etsi.org/technologies-clusters/technologies/ori>
- [4] A. Checko *et al.*, “Cloud RAN for mobile networks: A technology overview,” *IEEE Commun. Surveys Tuts.*, vol. 17, no. 1, pp. 405–426, 1st Quart., 2015.
- [5] A. Tukmanov, “Fronthauling for 5G and beyond,” in *Access, Fronthaul and Backhaul Networks for 5G & Beyond*. Stevenage, U.K.: Inst. Eng. Technol., 2017, pp. 139–168.
- [6] L. Liu *et al.*, “Analysis of handover performance improvement in cloud-RAN architecture,” in *Proc. 7th Int. Conf. Commun. Netw. China*, Kunming, China, 2012, pp. 850–855.
- [7] *Small Cell Virtualization Functional Splits and Use Cases, Release 7.0*, Small Cell Forum, Jan. 2016.
- [8] C. Sexton, N. J. Kaminski, J. M. Marquez-Barja, N. Marchetti, and L. A. DaSilva, “5G: Adaptable networks enabled by versatile radio access technologies,” *IEEE Commun. Surveys Tuts.*, vol. 19, no. 2, pp. 688–720, 2nd Quart., 2017.
- [9] M. Agiwal, A. Roy, and N. Saxena, “Next generation 5G wireless networks: A comprehensive survey,” *IEEE Commun. Surveys Tuts.*, vol. 18, no. 3, pp. 1617–1655, 3rd Quart., 2016.
- [10] “Study on new radio access technology: Radio access architecture and interfaces, V14.0.0 (2017–03),” 3GPP, Sophia Antipolis, France, Rep. TR 38.801, 2017.
- [11] S. González *et al.*, “5G-crosshaul: An SDN/NFV control and data plane architecture for the 5G integrated fronthaul/backhaul,” *Trans. Emerg. Telecommun. Technol.*, vol. 27, no. 9, pp. 1196–1205, Sep. 2016.
- [12] I. Chih-Lin, J. Huang, Y. Yuan, S. Ma, and R. Duan, “NGFI, the xHaul,” in *Proc. IEEE Globecom Workshops (GC Wkshps)*, San Diego, CA, USA, 2015, pp. 1–6.
- [13] *eCPRI Specification V1.1. Interface Specification*, Common Public Radio Interface, Jan. 2018.
- [14] M. Sauter, *From GSM to LTE*. Chichester, U.K.: Wiley, 2011.
- [15] R. Al-Obaidi, A. Checko, H. Holm, and H. Christiansen, “Optimizing cloud-RAN deployments in real-life scenarios using microwave radio,” in *Proc. Eur. Conf. Netw. Commun. (EuCNC)*, Paris, France, 2015, pp. 159–163.
- [16] A. Maeder *et al.*, “Towards a flexible functional split for cloud-RAN networks,” in *Proc. Eur. Conf. Netw. Commun.*, Bologna, Italy, 2014, pp. 1–5.
- [17] *Evolved Universal Terrestrial Radio Access (E-UTRA); Physical Channels and Modulation, V14.4.0*, 3GPP Standard TS 36.211, Sep. 2017.
- [18] P. Fischer, S. Yi, S. Chun, and Y. Lee, “User plane protocols,” in *LTE—The UMTS Long Term Evolution*. Chichester, U.K.: Wiley, 2011, pp. 87–120.
- [19] R. Agrawal, A. Bedekar, T. Kolding, and V. Ram, “Cloud RAN challenges and solutions,” *Ann. Telecommun.*, vol. 72, nos. 7–8, pp. 387–400, Aug. 2017.
- [20] “Further study on critical C-RAN technologies, version 1.0,” NGMN, Frankfurt, Germany, White Paper, Mar. 2015.
- [21] Q. Han, C. Wang, M. Levorato, and O. Simeone, “On the effect of fronthaul latency on ARQ in C-RAN Systems,” 2015.
- [22] H. van der Velde, “Control plane protocols,” in *LTE—The UMTS Long Term Evolution*. Chichester, U.K.: Wiley, 2011, pp. 57–86.
- [23] NTT DOCOMO, *R3-162102: CU-DU Split: Refinement for Annex A*, 3GPP, Sophia Antipolis, France, Oct. 2016.
- [24] M. Peng, Y. Sun, X. Li, Z. Mao, and C. Wang, “Recent advances in cloud radio access networks: System architectures, key techniques, and open issues,” *IEEE Commun. Surveys Tuts.*, vol. 18, no. 3, pp. 2282–2308, 3rd Quart., 2016.
- [25] M. Makhanbet, X. Zhang, H. Gao, and H. A. Suraweera, “An overview of cloud RAN: Architecture, issues and future directions,” in *Proc. 1st Int. Conf. Elect. Electron. Commun. Eng. (ELECOM)*, vol. 416, 2017, pp. 44–60, doi: [10.1007/978-3-319-52171-8\\_3](https://doi.org/10.1007/978-3-319-52171-8_3).
- [26] T. Pfeiffer, “Next generation mobile fronthaul and midhaul architectures [invited],” *IEEE/OSA J. Opt. Commun. Netw.*, vol. 7, no. 11, pp. B38–B45, Nov. 2015.
- [27] J. Liu, S. Xu, S. Zhou, and Z. Niu, “Redesigning fronthaul for next-generation networks: Beyond baseband samples and point-to-point links,” *IEEE Wireless Commun.*, vol. 22, no. 5, pp. 90–97, Oct. 2015.
- [28] J. Bartelt *et al.*, “5G transport network requirements for the next generation fronthaul interface,” *EURASIP J. Wireless Commun. Netw.*, vol. 2017, no. 1, p. 89, Dec. 2017, doi: [10.1186/s13638-017-0874-7](https://doi.org/10.1186/s13638-017-0874-7).
- [29] I. Chih-Lin, J. Huang, Y. Yuan, and S. Ma, “5G RAN architecture: C-RAN with NGFI,” in *5G Mobile Communications*. Cham, Switzerland: Springer Int., 2017, pp. 431–455, doi: [10.1007/978-3-319-34208-5\\_16](https://doi.org/10.1007/978-3-319-34208-5_16).
- [30] J. Bartelt, D. Wübben, P. Rost, G. Lessmann, and J. Fettweis, “Fronthaul for a flexible centralization in cloud radio access networks,” in *Backhauling/Fronthauling for Future Wireless Systems*, Wiley, 2016. [Online]. Available: <https://doi.org/10.1002/9781119170402.ch4>
- [31] D. Wubben *et al.*, “Benefits and impact of cloud computing on 5G signal processing: Flexible centralization through cloud-RAN,” *IEEE Signal Process. Mag.*, vol. 31, no. 6, pp. 35–44, Nov. 2014.
- [32] J. Bartelt *et al.*, “Fronthaul and backhaul requirements of flexibly centralized radio access networks,” *IEEE Wireless Commun.*, vol. 22, no. 5, pp. 105–111, Oct. 2015.
- [33] H. Niu, C. Li, A. Papathanassiou, and G. Wu, “RAN architecture options and performance for 5G network evolution,” in *Proc. IEEE Wireless Commun. Netw. Conf. Workshops (WCNCW)*, Istanbul, Turkey, 2014, pp. 294–298.
- [34] M. Peng, C. Wang, V. Lau, and H. V. Poor, “Fronthaul-constrained cloud radio access networks: Insights and challenges,” *IEEE Wireless Commun.*, vol. 22, no. 2, pp. 152–160, Apr. 2015.
- [35] J.-I. Kani, S. Kuwano, and J. Terada, “Options for future mobile backhaul and fronthaul,” *Opt. Fiber Technol.*, vol. 26, pp. 42–49, Dec. 2015.
- [36] C. Ranaweera, E. Wong, A. Nirmalathas, C. Jayasundara, and C. Lim, “5G C-RAN architecture: A comparison of multiple optical fronthaul networks,” in *Proc. IEEE Int. Conf. Opt. Netw. Design Model. (ONDM)*, Budapest, Budapest, 2017, pp. 1–6.
- [37] N. J. Gomes, P. Chanclou, P. Turnbull, A. Magee, and V. Jungnickel, “Fronthaul evolution: From CPRI to Ethernet,” *Opt. Fiber Technol.*, vol. 26, pp. 50–58, Dec. 2015.
- [38] D. Sabella *et al.*, “Benefits and challenges of cloud technologies for 5G architecture,” in *Proc. IEEE 81st Veh. Technol. Conf. (VTC Spring)*, Glasgow, U.K., 2015, pp. 1–5.
- [39] A. De La Oliva, J. A. Hernandez, D. Larrabeiti, and A. Azcorra, “An overview of the CPRI specification and its application to C-RAN-based LTE scenarios,” *IEEE Commun. Mag.*, vol. 54, no. 2, pp. 152–159, Feb. 2016.
- [40] M. Shafi *et al.*, “5G: A tutorial overview of standards, trials, challenges, deployment, and practice,” *IEEE J. Sel. Areas Commun.*, vol. 35, no. 6, pp. 1201–1221, Jun. 2017.
- [41] U. Dötsch *et al.*, “Quantitative analysis of split base station processing and determination of advantageous architectures for LTE,” *Bell Labs Tech. J.*, vol. 18, no. 1, pp. 105–128, Jun. 2013.
- [42] R. Agrawal *et al.*, “Architecture principles for cloud RAN,” in *Proc. IEEE 83rd Veh. Technol. Conf. (VTC Spring)*, Nanjing, China, 2016, pp. 1–5.
- [43] J. Gutiérrez *et al.*, “5G-XHaul: A converged optical and wireless solution for 5G transport networks,” *Trans. Emerg. Telecommun. Technol.*, vol. 27, no. 9, pp. 1187–1195, Sep. 2016.
- [44] G. O. Pérez, J. A. Hernández, and D. L. López, “Delay analysis of fronthaul traffic in 5G transport networks,” in *Proc. IEEE 17th Int. Conf. Ubiquitous Wireless Broadband*, Salamanca, Spain, 2017, pp. 1–5.
- [45] I. A. Alimi, A. L. Teixeira, and P. P. Monteiro, “Towards an efficient C-RAN optical fronthaul for the future networks: A tutorial on technologies, requirements, challenges, and solutions,” *IEEE Commun. Surveys Tuts.*, vol. 20, no. 1, pp. 708–769, 1st Quart., 2018.
- [46] G. Mountaser, M. L. Rosas, T. Mahmoodi, and M. Dohler, “On the feasibility of MAC and PHY split in cloud RAN,” in *Proc. IEEE Wireless Commun. Netw. Conf. (WCNC)*, San Francisco, CA, USA, 2017, pp. 1–6.
- [47] P. Arnold, N. Bayer, J. Belschner, and G. Zimmermann, “5G radio access network architecture based on flexible functional control / user plane splits,” in *Proc. Eur. Conf. Netw. Commun. (EuCNC)*, Oulu, Finland, 2017, pp. 1–5.
- [48] L. M. P. Hansen, *Design and Deployment Considerations for Cloud-RAN Based Mobile Networks*, Tech. Univ. Denmark, Lyngby, Denmark, 2017.
- [49] “Self-organised fronthauling for 5G and beyond,” in *Access, Fronthaul and Backhaul Networks for 5G & Beyond*, Inst. Eng. Technol., 2017, ch. 9, pp. 203–230, doi: [10.1049/PBTE074E\\_ch](https://doi.org/10.1049/PBTE074E_ch).



- [50] A. Garcia-Saavedra, J. X. Salvat, X. Li, and X. Costa-Perez, "WizHaul: On the centralization degree of cloud RAN next generation fronthaul," *IEEE Trans. Mobile Comput.*, vol. 17, no. 10, pp. 2452–2466, Oct. 2018.
- [51] Z. Guizani and N. Hamdi, "CRAN, H-CRAN, and F-RAN for 5G systems: Key capabilities and recent advances," *Int. J. Netw. Manag.*, vol. 27, no. 5, Sep. 2017, Art. no. e1973.
- [52] P. J. Urban *et al.*, "A tutorial on fiber monitoring for applications in analogue mobile fronthaul," *IEEE Commun. Surveys Tuts.*, to be published, doi: [10.1109/COMST.2018.2846747](https://doi.org/10.1109/COMST.2018.2846747).
- [53] C.-Y. Chang, R. Schiavi, N. Nikaiein, T. Spyropoulos, and C. Bonnet, "Impact of packetization and functional split on C-RAN fronthaul performance," in *Proc. IEEE Int. Conf. Commun. (ICC)*, Kuala Lumpur, Malaysia, 2016, pp. 1–7.
- [54] T. Wan and P. Ashwood-Smith, "A performance study of CPRI over Ethernet with IEEE 802.1Qbu and 802.1Qbv enhancements," in *Proc. IEEE Glob. Commun. Conf. (GLOBECOM)*, San Diego, CA, USA, 2015, pp. 1–6.
- [55] J. Duan, X. Lagrange, and F. Guilloud, "Performance analysis of several functional splits in C-RAN," in *Proc. IEEE 83rd Veh. Technol. Conf. (VTC Spring)*, vol. 2016, Nanjing, China, 2016, pp. 1–5, doi: [10.1109/VTCSpring.2016.7504410](https://doi.org/10.1109/VTCSpring.2016.7504410).
- [56] A. Checko, A. C. Juul, H. L. Christiansen, and M. S. Berger, "Synchronization challenges in packet-based cloud-RAN fronthaul for mobile networks," in *Proc. IEEE Int. Conf. Commun. Workshop (ICCW)*, London, U.K., 2015, pp. 2721–2726.
- [57] N. Shibata, S. Kuwano, J. Terada, and H. Kimura, "Dynamic IQ data compression using wireless resource allocation for mobile front-haul with TDM-PON [invited]," *J. Opt. Commun. Netw.*, vol. 7, no. 3, pp. A372–A378, Mar. 2015.
- [58] H. Wang, M. M. A. Hossain, and C. Cavdar, "Cloud RAN architectures with optical and mm-Wave transport technologies," in *Proc. 19th Int. Conf. Transp. Opt. Netw. (ICTON)*, Girona, Spain, 2017, pp. 1–4.
- [59] A. Checko, A. P. Avramova, M. S. Berger, and H. L. Christiansen, "Evaluating C-RAN fronthaul functional splits in terms of network level energy and cost savings," *J. Commun. Netw.*, vol. 18, no. 2, pp. 162–172, Apr. 2016.
- [60] C.-Y. Chang, N. Nikaiein, R. Knopp, T. Spyropoulos, and S. S. Kumar, "FlexCRAN: A flexible functional split framework over Ethernet fronthaul in cloud-RAN," in *Proc. IEEE Int. Conf. Commun. (ICC)*, Paris, France, 2017, pp. 1–7.
- [61] C.-Y. Chang, N. Nikaiein, and T. Spyropoulos, "Impact of packetization and scheduling on C-RAN fronthaul performance," in *Proc. IEEE Glob. Commun. Conf. (GLOBECOM)*, Washington, DC, USA, 2016, pp. 1–7.
- [62] D. Wang, Y. Wang, S. Meng, and X. Zhang, "Game based wireless fronthaul C-RAN baseband function splitting and placement," in *Proc. 12th Int. Conf. Mobile Ad-Hoc Sens. Netw. (MSN)*, Hefei, China, 2016, pp. 400–404.
- [63] A. Gowda, J. A. Hernández, D. Larrabeiti, and L. Kazovsky, "Delay analysis of mixed fronthaul and backhaul traffic under strict priority queuing discipline in a 5G packet transport network," *Trans. Emerg. Telecommun. Technol.*, vol. 28, no. 6, Jun. 2017, Art. no. e3168.
- [64] F. Musumeci *et al.*, "Optimal BBU placement for 5G C-RAN deployment over WDM aggregation networks," *J. Lightw. Technol.*, vol. 34, no. 8, pp. 1963–1970, Apr. 15, 2016.
- [65] D. Chitimala, K. Kondepu, L. Valcarenghi, M. Tornatore, and B. Mukherjee, "5G fronthaul-latency and jitter studies of CPRI over Ethernet," *J. Opt. Commun. Netw.*, vol. 9, no. 2, pp. 172–182, Feb. 2017.
- [66] I. Chih-Lin *et al.*, "Recent progress on C-RAN centralization and cloudification," *IEEE Access*, vol. 2, pp. 1030–1039, 2014.
- [67] N. P. Anthapadmanabhan, A. Walid, and T. Pfeiffer, "Mobile fronthaul over latency-optimized time division multiplexed passive optical networks," in *Proc. IEEE Int. Conf. Commun. Workshop (ICCW)*, London, U.K., 2015, pp. 62–67.
- [68] X. Liu, H. Zeng, N. Chand, and F. Effenberger, "Efficient mobile fronthaul via DSP-based channel aggregation," *J. Lightw. Technol.*, vol. 34, no. 6, pp. 1556–1564, Mar. 15, 2016.
- [69] L. Valcarenghi, K. Kondepu, and P. Castoldi, "Time-versus size-based CPRI in Ethernet encapsulation for next generation reconfigurable fronthaul," *IEEE/OSA J. Opt. Commun. Netw.*, vol. 9, no. 9, pp. D64–D73, Sep. 2017.
- [70] S. Megeed, X. Liu, H. Zeng, and F. Effenberger, "Demonstration of a FPGA-based CPRI-over-Ethernet real-time system achieving 120 Gb/s throughput over a 10-km SSMF link with 16 bi-directional 10GE connections," in *Proc. Opt. Fiber Commun. Conf.*, Los Angeles, CA, USA, 2017, pp. 1–3.
- [71] P. P. Monteiro *et al.*, "Mobile fronthaul RoF transceivers for C-RAN applications," in *Proc. 17th Int. Conf. Transp. Opt. Netw. (ICTON)*, Budapest, Hungary, 2015, pp. 1–4.
- [72] J.-Y. Sung, C.-W. Chow, C.-H. Yeh, and G.-K. Chang, "Two-level modulation scheme to reduce latency for optical mobile fronthaul networks," *Opt. Exp.*, vol. 24, no. 22, Oct. 2016, Art. no. 25767.
- [73] N. Shibata, K. Miyamoto, S. Kuwano, J. Terada, and A. Otaka, "System level performance of uplink transmission in split-PHY processing architecture with joint reception for future radio access," in *Proc. IEEE 26th Annu. Int. Symp. Pers. Indoor Mobile Radio Commun. (PIMRC)*, vol. 2015, Hong Kong, 2015, pp. 1375–1379, doi: [10.1109/PIMRC.2015.7343513](https://doi.org/10.1109/PIMRC.2015.7343513).
- [74] B. Guo, W. Cao, A. Tao, and D. Samardzija, "LTE/LTE-A signal compression on the CPRI interface," *Bell Labs Tech. J.*, vol. 18, no. 2, pp. 117–133, Sep. 2013.
- [75] M. Jaber, D. Owens, M. A. Imran, R. Tafazolli, and A. Tukmanov, "A joint backhaul and RAN perspective on the benefits of centralised RAN functions," in *Proc. IEEE Int. Conf. Commun. Workshops (ICC)*, Kuala Lumpur, Malaysia, 2016, pp. 226–231.
- [76] L. Valcarenghi, F. Giannone, D. Manicone, and P. Castoldi, "Virtualized eNB latency limits," in *Proc. 19th Int. Conf. Transp. Opt. Netw. (ICTON)*, Girona, Spain, 2017, pp. 1–4.
- [77] H. Gupta *et al.*, "How much is fronthaul latency budget impacted by RAN virtualisation?" in *Proc. IEEE Conf. Netw. Funct. Virtual. Softw. Defined Netw. (NFV-SDN)*, Berlin, Germany, 2017, pp. 315–320.
- [78] L. Ramalho, I. Freire, C. Lu, M. Berg, and A. Klautau, "Improved LPC-based fronthaul compression with high rate adaptation resolution," *IEEE Commun. Lett.*, vol. 22, no. 3, pp. 458–461, Mar. 2018.
- [79] S.-H. Cho *et al.*, "Cost-effective next generation mobile fronthaul architecture with multi-IF carrier transmission scheme," in *Proc. Opt. Fiber Commun. Conf.*, 2014, pp. 1–3.
- [80] A. S. Thyagaturu, Z. Alharbi, and M. Reisslein, "R-FFT: Function split at IFFT/FFT in unified LTE CRAN and cable access network," *IEEE Trans. Broadcast.*, vol. 64, no. 3, pp. 648–665, Sep. 2018.
- [81] *Transport Requirement for CU&DU Functional Splits Options*, document TSG RAN WG3 Meeting #93 R3-161813, 3GPP, Sophia Antipolis, France, Aug. 2016.
- [82] *R3-173402-Overall of Proposed L1 Processing Diagram, Rev3*, 3GPP, Sophia Antipolis, France, 2017.
- [83] G. O. Pérez, J. A. Hernández, and D. Larrabeiti, "Fronthaul network modeling and dimensioning meeting ultra-low latency requirements for 5G," *IEEE/OSA J. Opt. Commun. Netw.*, vol. 10, no. 6, pp. 573–581, Jun. 2018.
- [84] A. Lund, *Signal Processing for Next Generation Fronthaul Interface (NGFI)*, Tech. Univ. Denmark, Lyngby, Denmark, 2016.
- [85] R. Al-Obaidi, *Next Generation Fronthaul Networks*, Tech. Univ. Denmark, Lyngby, Denmark, 2016.
- [86] K. Miyamoto, T. Shimizu, J. Terada, and A. Otaka, "Low latency symbol level transmission scheme for mobile fronthaul with intra PHY split RAN architecture," in *Proc. Eur. Conf. Opt. Commun. (ECOC)*, Gothenburg, Sweden, 2017, pp. 1–3.
- [87] D. Boviz, A. Gopalasingham, C. S. Chen, and L. Roulet, "Physical layer split for user selective uplink joint reception in SDN enabled cloud-RAN," in *Proc. Aust. Commun. Theory Workshop (AusCTW)*, Melbourne, VIC, Australia, 2016, pp. 83–88.
- [88] K. Miyamoto, S. Kuwano, J. Terada, and A. Otaka, "Split-PHY processing architecture to realize base station coordination and transmission bandwidth reduction in mobile fronthaul," in *Proc. Opt. Fiber Commun. Conf. Exhib. (OFC)*, Los Angeles, CA, USA, 2015, pp. 1–3.
- [89] K. Miyamoto, S. Kuwano, J. Terada, and A. Otaka, "Analysis of mobile fronthaul bandwidth and wireless transmission performance in split-PHY processing architecture," *Opt. Exp.*, vol. 24, no. 2, p. 1261, Jan. 2016.
- [90] K. Miyamoto, S. Kuwano, T. Shimizu, J. Terada, and A. Otaka, "Performance evaluation of Ethernet-based mobile fronthaul and wireless CoMP in split-PHY processing," *J. Opt. Commun. Netw.*, vol. 9, no. 1, pp. A46–A54, Jan. 2017.
- [91] I. Afolabi, T. Taleb, K. Samdanis, A. Ksentini, and H. Flinck, "Network slicing and softwarization: A survey on principles, enabling technologies and solutions," *IEEE Commun. Surveys Tuts.*, vol. 20, no. 3, pp. 2429–2453, 3rd Quart., 2018.
- [92] N. Makris, P. Basaras, T. Korakis, N. Nikaiein, and L. Tassiulas, "Experimental evaluation of functional splits for 5G cloud-RANs," in *Proc. IEEE Int. Conf. Commun. (ICC)*, Paris, France, 2017, pp. 1–6.

- [93] S. Nishihara, S. Kuwano, K. Miyamoto, J. Terada, and A. Ootaka, "Study on protocol and required bandwidth for 5G mobile fronthaul in C-RAN architecture with MAC-PHY split," in *Proc. 22nd Asia-Pac. Conf. Commun. (APCC)*, Yogyakarta, Indonesia, 2016, pp. 1–5.
- [94] L. Valcarenghi, K. Kondepudi, F. Giannone, and P. Castoldi, "Requirements for 5G fronthaul," in *Proc. 18th Int. Conf. Transp. Opt. Netw. (ICTON)*, Trento, Italy, 2016, pp. 1–5.
- [95] P. Assimakopoulos, G. S. Birring, M. K. Al-Hares, and N. J. Gomes, "Ethernet-based fronthauling for cloud-radio access networks," in *Proc. 19th Int. Conf. Transp. Opt. Netw. (ICTON)*, Girona, Spain, 2017, pp. 1–4.
- [96] M. J. Roldan, P. Leithead, and J. Mack, "Experiments and results of a mmW transport platform to enable 5G cloud RAN lower layer splits," in *Proc. IEEE Long Island Syst. Appl. Technol. Conf. (LISAT)*, Farmingdale, NY, USA, 2018, pp. 1–6.
- [97] G. S. Birring, P. Assimakopoulos, and N. J. Gomes, "An Ethernet-based fronthaul implementation with MAC/PHY split LTE processing," in *Proc. GLOBECOM IEEE Glob. Commun. Conf.*, Singapore, 2017, pp. 1–6.
- [98] P. Assimakopoulos, G. S. Birring, and N. J. Gomes, "Effects of contention and delay in a switched Ethernet evolved fronthaul for future cloud-RAN applications," in *Proc. Eur. Conf. Opt. Commun. (ECOC)*, vol. 2017, Gothenburg, Sweden, 2017, pp. 1–3, doi: [10.1109/ECOC.2017.8346013](https://doi.org/10.1109/ECOC.2017.8346013).
- [99] D. Harutyunyan and R. Riggio, "Flexible functional split in 5G networks," in *Proc. 13th Int. Conf. Netw. Service Manag. (CNSM)*, Tokyo, Japan, 2017, pp. 1–9.
- [100] J. Baranda *et al.*, "Orchestration of end-to-end network services in the 5G-crosshaul multi-domain multi-technology transport network," *IEEE Commun. Mag.*, vol. 56, no. 7, pp. 184–191, Jul. 2018.
- [101] X. Wang *et al.*, "Centralize or distribute? A techno-economic study to design a low-cost cloud radio access network," in *Proc. IEEE Int. Conf. Commun. (ICC)*, 2017, pp. 1–7.
- [102] O. Chabbouh, S. Ben Rejeb, N. Agoulmine, and Z. Choukair, "Cloud RAN architecture model based upon flexible RAN functionalities split for 5G networks," in *Proc. 31st Int. Conf. Adv. Inf. Netw. Appl. Workshops (WAINA)*, 2017, pp. 184–188.
- [103] M. Y. Arslan, K. Sundaresan, and S. Rangarajan, "Software-defined networking in cellular radio access networks: Potential and challenges," *IEEE Commun. Mag.*, vol. 53, no. 1, pp. 150–156, Jan. 2015.
- [104] P. Monti *et al.*, "A flexible 5G RAN architecture with dynamic baseband split distribution and configurable optical transport," in *Proc. 19th Int. Conf. Transp. Opt. Netw. (ICTON)*, 2017, p. 1.
- [105] X. Wang, A. Alabbasi, and C. Cavdar, "Interplay of energy and bandwidth consumption in CRAN with optimal function split," in *Proc. IEEE Int. Conf. Commun. (ICC)*, Paris, France, 2017, pp. 1–6.
- [106] J. Liu, S. Zhou, J. Gong, Z. Niu, and S. Xu, "Graph-based framework for flexible baseband function splitting and placement in C-RAN," in *Proc. IEEE Int. Conf. Commun. (ICC)*, 2015, pp. 1958–1963.
- [107] A. Garcia-Saavedra, G. Iosifidis, X. Costa-Perez, and D. J. Leith, "FluidRAN: Optimized vRAN/MEC orchestration," in *Proc. INFOCOM*, 2018, pp. 1–9.
- [108] A. Alabbasi, X. Wang, and C. Cavdar, "Optimal processing allocation to minimize energy and bandwidth consumption in hybrid CRAN," *IEEE Trans. Green Commun. Netw.*, vol. 2, no. 2, pp. 545–555, Jun. 2018.
- [109] D. Harutyunyan and R. Riggio, "Flex5G: Flexible functional split in 5G networks," *IEEE Trans. Netw. Service Manag.*, vol. 15, no. 3, pp. 961–975, Sep. 2018, doi: [10.1109/TNSM.2018.2853707](https://doi.org/10.1109/TNSM.2018.2853707).
- [110] I. Koutsopoulos, "Optimal functional split selection and scheduling policies in 5G radio access networks," in *Proc. IEEE Int. Conf. Commun. Workshops (ICC Workshops)*, Paris, France, 2017, pp. 993–998.
- [111] Y. Alfadhli *et al.*, "Real-time demonstration of adaptive functional split in 5G flexible mobile fronthaul networks," in *Proc. OFC*, 2018, pp. 1–3.
- [112] S. S. Kumar *et al.*, "FLEXCRAN: Cloud radio access network prototype using OpenAirInterface," in *Proc. 9th Int. Conf. Commun. Syst. Netw. (COMSNETS)*, 2017, pp. 421–422.
- [113] J. Zou *et al.*, "Demonstration of X-haul architecture for 5G over converged SDN fiber network," in *Proc. Opt. Fiber Commun. Conf. Expo.*, San Diego, CA, USA, 2018, pp. 1–3.
- [114] K. Kondepudi, N. Sambo, F. Giannone, P. Castoldi, and L. Valcarenghi, "Orchestrating lightpath adaptation and flexible functional split to recover virtualized RAN connectivity," in *Proc. Opt. Fiber Commun. Conf. Expo. (OFC)*, San Diego, CA, USA, 2018, pp. 1–3.
- [115] Z. Zaidi *et al.*, "Will SDN be part of 5G?" *IEEE Commun. Surveys Tuts.*, to be published, doi: [10.1109/COMST.2018.2836315](https://doi.org/10.1109/COMST.2018.2836315).
- [116] *NG-RAN: Architecture Description (Release 15)*, V15.0.0, 3GPP Standard TS.38.401, Dec. 2017.
- [117] *IEEE 1914 Website*. Accessed: Feb. 13, 2018. [Online]. Available: <http://sites.ieee.org/sagroups-1914/>
- [118] *Project Authorization Request P1914.1: Standard for Packet-Based Fronthaul Transport Networks*, IEEE 1914 NGFI, Working Group, 2015.
- [119] N. J. Gomes *et al.*, "Boosting 5G through Ethernet: How evolved fronthaul can take next-generation mobile to the next level," *IEEE Veh. Technol. Mag.*, vol. 13, no. 1, pp. 74–84, Mar. 2018.
- [120] *Draft Standard for Packet-Based Fronthaul Transport Networks*, IEEE Standard P1914.1/D1.1, 2018.
- [121] A. Nasrallah *et al.*, "Ultra-low latency (ULL) networks: The IEEE TSN and IETF DetNet standards and related 5G ULL research," *IEEE Commun. Surveys Tuts.*, to be published, doi: [10.1109/COMST.2018.2869350](https://doi.org/10.1109/COMST.2018.2869350).
- [122] *Draft Standard for Radio Over Ethernet Encapsulations and Mappings*, IEEE Standard P1914.3/D3.2, 2018.
- [123] *Time-Sensitive Networking for Fronthaul*, IEEE Standard P802.1CM/D2.0, 2018.
- [124] "Transport network support of IMT-2020/5G," ITU-T, Geneva, Switzerland, Rep. GSTR-TN5G, 2018.
- [125] *NGMN Overview on 5G RAN Functional Decomposition*, Next Gener. Mobile Netw., 2018.
- [126] *Next Generation RAN Architecture*. Accessed: Feb. 13, 2018. [Online]. Available: <http://www.xrان.org/>
- [127] NTT DOCOMO, AT&T, China Mobile, and Deutsche Telekom. (2018). *Joint Press Release*. [Online]. Available: [https://www.prnewswire.com/news-releases/industry-leaders-launch-oran-alliance-300604720.html?tc=eml\\_cleartime](https://www.prnewswire.com/news-releases/industry-leaders-launch-oran-alliance-300604720.html?tc=eml_cleartime)
- [128] "Control, user and synchronization plane specification, v.1.0," xRAN Fronthaul, Working Group.
- [129] "xRAN Fronthaul working group white paper, v.1.0," xRAN Fronthaul, Working Group, 2018.
- [130] *Telecom Infra Project*. Accessed: Feb. 13, 2018. [Online]. Available: <http://telecominfraproject.com/>
- [131] *Mobile CORD*. Accessed: Feb. 13, 2018. [Online]. Available: <https://wiki.opencord.org/display/CORD/Mobile+CORD>
- [132] *5G Crosshaul Project*. Accessed: Feb. 16, 2018. [Online]. Available: <http://5g-crosshaul.eu/>
- [133] X. Costa-Perez *et al.*, "5G-crosshaul: An SDN/NFV integrated fronthaul/backhaul transport network architecture," *IEEE Wireless Commun.*, vol. 24, no. 1, pp. 38–45, Feb. 2017.
- [134] Y. Huang, C. Lu, M. Berg, and P. Ödling, "Functional split of zero-forcing based massive MIMO for fronthaul load reduction," *IEEE Access*, vol. 6, pp. 6350–6359, 2018.
- [135] *5G XHaul*. Accessed: Feb. 16, 2018. [Online]. Available: <http://www.5g-xhaul-project.eu/>
- [136] C. Wagner *et al.*, "Full C-band tunable MEMS-VCSEL for next generation G.metro mobile front- and backhauling," in *Proc. Opt. Fiber Commun. Conf.*, Los Angeles, CA, USA, 2017, pp. 1–3.
- [137] *5G Picture*. Accessed: Feb. 16, 2018. [Online]. Available: <http://www.5g-picture-project.eu/>
- [138] *Eurostars Projects*. Accessed: Feb. 16, 2018. [Online]. Available: <https://www.eurostars-eureka.eu/project/id/10898>
- [139] L. M. P. Larsen, M. S. Berger, and H. L. Christiansen, "Fronthaul for cloud-RAN enabling network slicing in 5G mobile networks," *Wireless Commun. Mob. Comput.*, vol. 2018, Aug. 2018, Art. no. 4860212. [Online]. Available: <https://doi.org/10.1155/2018/4860212>
- [140] *iCirrus*. Accessed: Feb. 21, 2018. [Online]. Available: <http://www.icirrus-5gnet.eu/>
- [141] *5G CORAL Project Webpage*. Accessed: Aug. 13, 2018. [Online]. Available: <http://5g-coral.eu/>
- [142] P.-H. Kuo *et al.*, "An integrated edge and Fog system for future communication networks," in *Proc. IEEE Wireless Commun. Netw. Conf. Workshops (WCNCW)*, 2018, pp. 338–343.
- [143] *OSA*. Accessed: Feb. 13, 2018. [Online]. Available: <http://www.openairinterface.org/>
- [144] D. H. Hailu, B. G. Gebrehaweria, S. H. Kebede, G. G. Lema, and G. T. Tesfamariam, "Mobile fronthaul transport options in C-RAN and emerging research directions: A comprehensive study," *Opt. Switch. Netw.*, vol. 30, pp. 40–52, Nov. 2018.
- [145] H. Son and S. M. Shin, *Fronthaul Size: Calculation of Maximum Distance Between RRH and BBU*, NMC Consult., London, U.K., 2014.



**Line M. P. Larsen**, born Hansen, received the M.Sc.Eng. degree in telecommunication from the Technical University of Denmark (DTU) in 2017, where she is currently pursuing Ph.D. degree with the Networks Technology and Service Platforms Group, Department of Photonics Engineering. Her interests include mobile networks and network architectures especially Cloud-RAN and fronthaul/crosshaul networks.



**Henrik L. Christiansen** received the M.Sc.E.E. and Ph.D. degrees in telecommunications from the Technical University of Denmark, where he is an Associate Professor in mobile communication. He spent several years in the telecom industry. His main areas of research are mobile network architectures and planning, especially fronthaul networks for C-RAN and evolution toward 5G mobile.



**Aleksandra Checko** received the double M.Sc. degrees in telecommunication from the Technical University of Denmark (DTU) and the Lodz University of Technology, Poland, in 2011 and the Ph.D. degree from DTU done in collaboration with MTI Radiocomp on C-RAN in 2016. Her previous experience included working as a Project Manager and Senior Systems Engineer with MTI Radiocomp, where she worked on 4G and 5G fronthaul architecture, as well as supported IP cores and RRH development and testing. She is currently an SD-RAN

Product Manager with IS-Wireless. Her interests include mobile networks, especially their architecture, protocols, synchronization, and capacity planning methods.