

Monitor Indoor Air Quality to Assess the Risk of COVID-19 Transmission

Timotei Bidilă
Automatic Control and Industrial
Informatics Department
University POLITEHNICA of
Bucharest
Bucharest, Romania
timotei.bidila@aii.pub.ro

Radu Nicolae Pietraru
Automatic Control and Industrial
Informatics Department
University POLITEHNICA of
Bucharest
Bucharest, Romania
radu.pietraru@upb.ro

Anca Daniela Ioniță
Automatic Control and Industrial
Informatics Department
University POLITEHNICA of
Bucharest
Bucharest, Romania
anca.ionita@upb.ro

Adriana Olteanu
Automatic Control and Industrial
Informatics Department
University POLITEHNICA of
Bucharest
Bucharest, Romania
adriana.olteanu@upb.ro

Abstract— The year 2020 will remain in the memory of all mankind as the year of the COVID-19 pandemic. The pandemic has affected the world economy, caused more than a million deaths in 2020 alone, changed the way people work and learn and, last but not least, changed the way people interact in society. Social distancing, along with wearing a face mask, is the best solution to prevent the spread of COVID-19 virus. What happens when in certain spaces social distance is difficult and can be accidentally violated without intention? In the absence of widely available tests, not only for people but also for surfaces or indoor air, the risk of contamination is very difficult to assess. This paper proposes a simple method, with low cost and widely implementable, to warn of respecting the density of people in a room. It proposes a dual monitoring system based on Internet of Things (IoT) to assess the indoor air quality and risk of COVID-19 transmission.

Keywords— indoor air quality, sensor systems, Internet of Things, risk of COVID-19 transmission

I. INTRODUCTION

Air pollution is a general concern now. It is true that most global action focuses on climate change caused by air pollution, but there are strong actions related to the health of the population affected by air quality. Most alarm signals come to warn about the quality of the air outside but, especially in the last period affected by the isolation imposed by the COVID-19 virus, people spend most of their time inside buildings. Of course, indoor air quality is affected by outdoor air quality, but in addition, there are several factors that significantly worsen indoor air quality and severely affect the health of a building's occupants. This paper investigates whether the indoor environment is a controllable vector for the spread of microorganisms and viruses. Can indoor air quality facilitate or inhibit their spread?

Indoor air quality (IAQ) refers to the quality of the air in and around buildings. IAQ can be affected by several specific sources of pollution and has short- and long-term effects on human health. The immediate effects of indoor pollution include allergic effects, headaches, dizziness and fatigue, but the effects of long-term exposure can lead to serious respiratory illness, heart disease and even cancer. Nag presents in detail the diseases caused by pollution inside buildings [1] and introduces the term "Sick Building Syndrome" (SBS) as an epidemic of diseases caused by life inside a building. This term describes several serious health

problems that have been rising in cities around the world for decades.

Apart the health problems directly generated by indoor air quality, discussed in Section II, another serious side effect of a low index of indoor air quality is the favoring of the transmission of diseases caused by microorganisms and viruses. It is also possible to correlate the level of indoor pollution with the risk factor of airborne transmission of diseases (Section III). The paper proposes an indoor air quality monitoring and transmission risk assessment system for COVID-19, the architecture of the dual monitoring system is described in Section IV. The planning of its testing is presented in section V, followed by a discussion of the results in section VI.

II. INDOOR AIR QUALITY AND VOLATILE ORGANIC COMPOUNDS

The domestic sources of pollution inside a building are varied and include: the use of heating installations by combustion, the use of detergents and cleaning products, the improper use of ventilation, cooling and air heating installations, the use of tobacco products, excess humidity and even common activities such as cooking. These activities lead to a decrease in indoor air quality mainly through the emission of volatile organic compounds (VOCs). In [2] VOCs are identified as one of the main sources of indoor pollution along with Nitric oxides (NO_x), Sulfur dioxide (SO₂) and carbon monoxide (CO). VOCs in indoor pollution is increasing as a share due to excessive use of chemicals for cleaning and renovation. Examples of volatile organic pollutants include: tetrachloroethylene (from cleaning solutions); heptane, decane, toluene, xylene (present in solvents); eucalyptol, limonene (present in cosmetics), isobutanol (paints); butyl acetate, heptane (substance present in synthetic floors and carpets).

For the parameter that measures the total emissions of organic volatile substances, the abbreviation TVOC (Total Volatile Organic Compound) is used. The German Federal Environmental Agency [3] has defined a scale for assessing the health risk of VOCs pollution inside buildings (Table I).

Several specialized studies show VOCs as the main source of pollution in various types of indoor spaces. In [4] an

analysis of indoor air quality in 37 industrial sectors is made and it is proposed as a reference parameter the TVOC level with quality values between $300\mu\text{g}/\text{m}^3$ (ideal level) and $3000\mu\text{g}/\text{m}^3$ (limit level). In [5] it is shown that the classic renovation of the interior of a building generates a level of TVOC close to the upper limit for a period between 6 and 12 months.

TABLE I. TVOC POLLUTION ASSESSMENT SCALE

LEVEL	RECOMMENDED ACTIONS	EXPOSURE LIMIT	TVOC [PPB]
5 UNHEALTHY	AVOIDANCE / STRONG VENTILATION	HOURS	2200 - 5500
4 POOR	STRONG VENTILATION	< 1 MONTHS	660 - 2200
3 MODERATE	VENTILATION	< 12 MONTHS	220 - 660
2 GOOD	VENTILATION	NO LIMIT	65 - 220
1 EXCELLENT	NO ACTIONS	NO LIMIT	0 - 65

Some studies highlight certain categories of indoor spaces with a high index of air pollution with VOCs. In [6] it is shown that in nail salons the TVOC level can reach values of up to 12000ppb during working hours. Chen and Shao show that the TVOC level can reach 900ppb in a karaoke room where meals are served [7]. Oh et al. make an analysis of the health risks of exposure to VOCs in underground car parks by making estimates based on exposure time for users and employees [8].

Another category of studies highlights an additional source of VOCs than those discussed so far: humans. This source of VOCs is very important for this work because it is the basis for assessing the risk of disease spreading. Studies show that in buildings where many people spend a long time have a higher level of VOCs. Through breathing, people emit VOCs and in turn become a factor in polluting the environment in which they live. In [9] an evaluation is made of seven types of rooms in a Japanese university (lecture room, seminar room, three types of laboratories, a computer room, a library). Except for a laboratory that had very high TVOC values due to the chemicals used in the experiments, all other rooms showed increases in TVOC values proportional to the number of occupants (students and teachers). Statistical analyses performed in schools in the USA [10] and Romania [11] show that the lack of adequate ventilation in crowded school spaces causes immediate health problems such as asthma or allergies due to excessive humidity and poor air quality (identified by odors that are actually VOCs). Kumar et al. conduct a one-year analysis of indoor air quality in a New Delhi library by comparing outdoor air quality (ventilation) with indoor air quality [12]. It is concluded that indoor air quality (targeting TVOC values) is much more dangerous than outdoor pollution due to the chemicals used in the cleaning process and due to the large number of people inside. A

monitoring of the level of VOCs in a large hospital [13] showed that the area most affected by pollution is the waiting room of the hospital where there is the largest crowd of people in the whole hospital (except for the pharmacy where chemicals are handled).

Considering the above, we can conclude that VOCs are an important factor that influences indoor air quality. Starting from the hypothesis that one can control the factors that lead to the release of VOCs in the air (renovations, heating by combustion, handling of chemicals) our research question is: can one obtain information on the density of people by measuring the level of TVOC in a room?

III. THE LINK BETWEEN INDOOR AIR QUALITY AND THE SPREAD OF DISEASE

Many pathogens have air as a vector of transmission (airborne transmission). The magnitude of the current pandemic caused by the COVID-19 virus is due to the ease of transmitting the disease through the air. The best methods to prevent the spread of SARS-CoV-2 disease are social distance and wearing a face mask. The social distance in indoor spaces translates into respecting a certain density of people. Without doing microbiological testing of people or air, one can only consider a risk associated with a certain situation. There are proposals aimed at disinfecting the air with UV rays [14] but, without its large-scale implementation, the only solution to reduce the risk of infection is by ventilation. In the absence of clear pollutants (chemicals, fuel combustion, synthetic materials) poor indoor air quality can only be explained by a high density of people and poor ventilation. In other words, poor indoor air quality indicates a high-risk scenario for airborne disease transmission.

Sun and Zhai define two indices, P_d - the probability of social distancing and E_v - the effectiveness of ventilation, to calculate the probability of COVID-19 infection using a Wells-Riley model [15]. In [16] the role of environmental factors in the airborne transmission of COVID-19 virus is verified and it is concluded that the most favorable environment for spread is closed spaces with poor ventilation. Borisova and Komisarenko show that air pollution (dust particles or larger molecules) can be an air transport vehicle for COVID-19 virus [17] and moreover there is a possibility that the neurological symptoms of SARS-CoV-2 disease may be aggravated by this mode of transmission. An analysis performed in a hospital through laboratory tests of RT-PCR type performed on samples taken from the environment shows that classical mechanical ventilation is a good solution to prevent the spread of COVID-19 virus [18].

The influences of weather conditions and air quality on the intensity of the first wave of Covid-19 (winter - spring 2020) were evaluated in studies conducted in severely affected countries. The study presented in [19] conducted in Wuhan, China shows a significant increase in mortality related to pollution and atmospheric humidity. [20] notes a peak in the level of pollution that preceded the pandemic wave in Northern Italy in the spring of 2020 suggesting a direct correlation between the level of air pollution and the rate of spread of COVID-19 virus.

Given that the most common form of Covid-19 transmission is indoor airborne [21] and that there is sufficient evidence to show a direct link between indoor air quality and

the risk of airborne transmission of the virus, we propose a dual monitoring system for assessing both the indoor air quality and the risk of spreading the virus. Such system is also expected to bring new insights in relation with the research question in previous section.

IV. DUAL MONITORING SYSTEM BASED ON IoT

The functionality of the dual monitoring system involves the measurement of the environmental parameters air temperature and humidity and the TVOC pollution parameter. The system must be low cost and easy to use for large scale implementation. It must be able to determine the risk of spreading the COVID-19 virus based on the values measured in the environment. It is not a system of microbiological analysis and does not aim to detect the presence of COVID-19 virus in the air or to detect if a person present in the room is infected.

The system is based on the Espressif ESP8266 microprocessor [22] which provides the computing power needed to process the purchased data, has low power consumption and benefits from WiFi connectivity. For the actual implementation, the Adafruit Feather HUZZAH development board [23] was used, which allows the rapid development of systems based on ESP8266 and ensures the power supply part of the system from a 5V voltage source or from a 3.7V battery. HTU21D (temperature and humidity) [24] and CCS811 (TVOC) [25] digital sensors will be used to measure the environmental and TVOC parameters. The measurement of ambient temperature and humidity is very important because the TVOC sensor allows the automatic compensation of the measurements according to these two parameters. The communication between the development board and the two sensors will be done through the TWI bus (Two-Wire Interface) and the interconnection mode is shown in Figure 1.

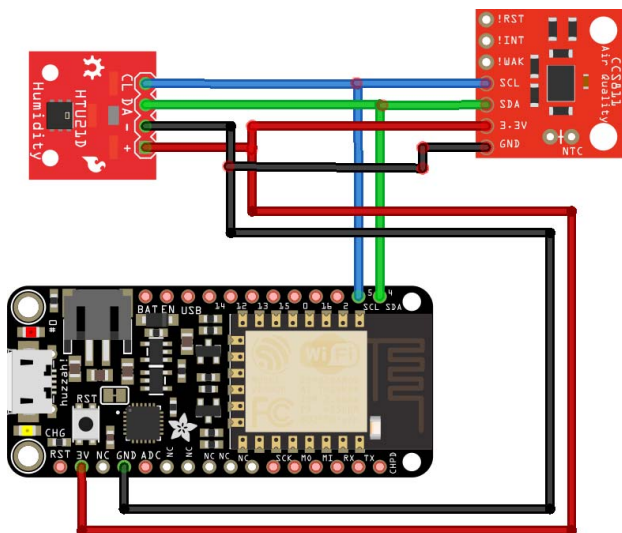

Fig. 1. Interconnection of electronic components of the system

The sensors and development board and microprocessor are common components that are commercially available and are currently used in various studies and specialized projects (such as [13], [26], [27], [28]). Given this consideration, one

can emphasize the premises for a large-scale implementation of such a dual monitoring system.

Data retrieved from sensors are sent over the Internet to an IoT platform to be stored and made available to users for viewing and analysis (Figure 2). The architecture is an IoT architecture and allows the monitoring of an unlimited number of rooms (an unlimited number of monitoring systems). Current studies show that this architecture is best suited for indoor air quality monitoring systems [29]. The communication between the monitoring systems and the IoT platform is performed using the MQTT protocol. The IoT platform used is the open-source ThingsBoard (version 3.1.1) platform [30] installed on a server running the CentOS 7 Linux operating system. All data is stored using a PostgreSQL database (version 11).

The ThingsBoard platform allows the management of connected IoT devices, the recording and processing of information received from monitoring systems, the definition of alarms triggered by received or processed data; it provides users with a graphical system for consulting information (dashboard system). The platform allows the connection of a large number (limited only by the available hardware resources) of devices giving scalability to the monitoring system.

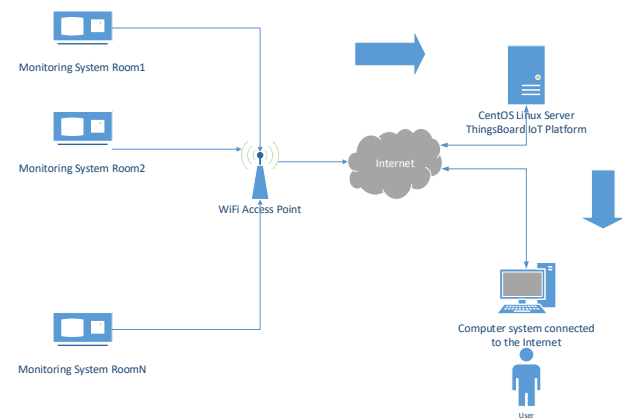

Fig. 2. Interconnection of system network components

Compared to conventional counting systems that are based on sensors placed at the entrance of a room, the dual monitoring system has the following advantages:

- has a much simpler installation, does not require modification of access paths.
- it is much more discreet and does not induce the impression that people are strictly supervised.
- allows monitoring the air quality in the room, a major advantage for people's health.

V. TESTING THE MONITORING SYSTEM

The system was tested using two monitoring devices: AIR811 Room 1 and AIR811 Room 2. From a hardware point of view, the only difference between the two devices is that AIR811 Room 1 also has a 0.96-inch monochrome OLED screen connected via TWI to the development board. For the AIR811 Room1 device, the OLED screen displays the

measured parameters locally. This hardware variation was made to evaluate the immediate response of the people to a decrease in the air quality in the room.

The two devices were installed in two rooms of approximately equal volume (area of 20 square meters, height of 2.5 meters). The sensors were positioned at a height of 1.5 meters from the floor on the wall opposite the windows in the room (windows representing natural ventilation paths). None of the rooms has undergone renovation work in the last year. No furniture or decorative elements have been introduced in any of the rooms in the last year. None of the rooms had any chemicals stored. No tobacco products were used in any of the rooms. Measurements performed during the intervals in which cleaning operations were performed were ignored. No air filtration devices were used in both rooms, no automatic ventilation devices were used - the ventilation was done exclusively manually, the only heating sources were the liquid-based ones (hot water radiators). The measurements were performed for 6 months and an attempt was made to determine the influence of the number of people in each room on the air quality in the absence of other factors that influence the TVOC level.

Both sensors use four parameters to the IoT platform: air temperature and humidity (measured by the HTU21S sensor); TVOC and eCO₂ levels (reported by CCS811 sensor). eCO₂ is the estimated carbon dioxide from the measured TVOC level. This parameter is calculated and reported by the CCS811 sensor starting from the premise that the TVOC level is generated entirely by human respiration, which also involves CO₂ emissions. It is not the same as the level of CO₂ in a room [31], this parameter was not analyzed in any way because it is proportional to the measured TVOC level. All four parameters can be viewed comparatively (between the two chambers) on the last seven days of measurement in the dashboard created on the ThingsBoard platform (Figure 3 shows the graph of temperature evolution).

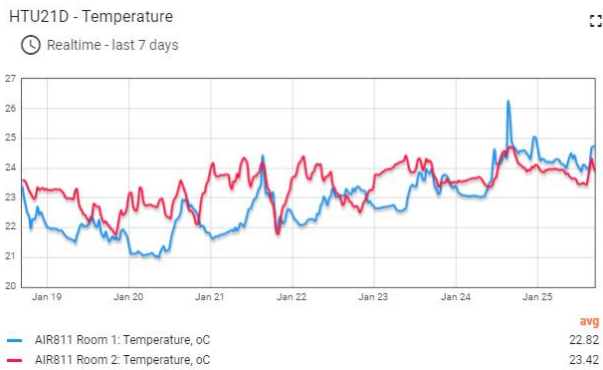

Fig. 3. Temperature graph for the last 7 days in the ThingsBoard dashboard

VI. DISCUSSION OF TEST RESULTS

The situations evaluated by the test setting described in the previous section were: (i) clean air with natural ventilation, (ii) stable pollution level without people in the room and, (iii) stable pollution level with known number of people in the room for a certain period. The following variations could be observed repetitively and consistently:

- In the case of natural ventilation, both sensors react in the same way, the TVOC values suddenly

decreasing to values below 10ppb (the first green arrow in the graph in Figure 4). This situation can be used in the case of an automatic analysis to mark the ventilation actions. When closing the windows (stopping the ventilation) the TVOC values increase during about two hours and stabilize.

- In the case of measurement without people in the room, there is a constant value of TVOC around 200ppb (the second green arrow in Figure 4 AIR811 Room 1). This value remains constant for long intervals and can be explained by residual VOC emissions of objects in the room. This value can be taken as a benchmark for empty room.
- The presence of a single person in the room generated TVOC values ranging between 300 and 400 ppm for an interval of 4-8 hours spent in the room (the second green arrow in Figure 4 AIR811 Room 2). The presence of two people in the room leads to an increase in TVOC to 900ppb in the first four hours (first green arrow in Figure 5 AIR811 Room 2) and values increase to 1200ppb in the next four hours (second green arrow in Figure 5 AIR811 Room 2).

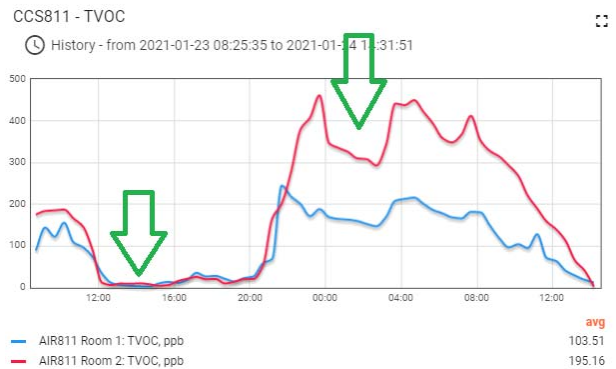

Fig. 4. TVOC values for ventilation operations / empty room cases and one person in the room



Fig. 5. TVOC values for one and two person(s) in the room

The system was not tested for more than two people in the room because the tests were performed during the national quarantine period. Both test participants were young adults. A further future assessment is needed to see if the TVOC levels generated by other age groups (children and the elderly) radically influence the method of determining the number of people. The extension of the tests will be done in a later study

when possible. Even so, the analyzed values highlighted the following characteristics of the measured TVOC parameter:

- The speed of variation of the measured TVOC parameter is proportional to the affected air volume. In the case of ventilation when the volume of air replaced at room level is significant, the variation takes place very quickly - the variation takes place within minutes. When the factor that changes the proportion of gases inside is human respiration (small volume) then the variation is slow - it takes place within hours. The monitoring system cannot be used for rooms where people spend little time (halls or receptions) but can be used successfully in rooms where people spend at least an hour (classrooms, cinemas, offices).
- If all common sources of pollution are kept under control (chemicals, combustion heating, tobacco products), the measurement of TVOC may indicate the stationary presence of persons. The system can be used to determine the density of people in a room.
- Even if the dynamics of the TVOC parameter on short time intervals is high (frequent changes) they fall within typical intervals for the conditions of the scenario in which they fall (empty room, ventilated room, presence of a person). The system provides the stability needed to determine the scenario in which only the measured TVOC value is known. The use of average values at time intervals can be considered in future evaluations.

VII. CONCLUSIONS

The study carried out on the scientific literature established that:

- Indoor air pollution is a factor that causes serious diseases both through long-term exposure and short-term exposure.
- One of the main factors of indoor air pollution is VOCs.
- The factors that lead to VOC pollution of the air inside the buildings are of an artificial nature (cleaning products, products used for renovation, heating by combustion) but also of a human nature (breathing).
- Poor indoor air quality favors the transmission of diseases.
- In the case of airborne diseases (such as SARS-CoV-2) the premises inside poorly ventilated buildings are the main sources of spread.
- Social distancing (inversely proportional to the density of people in a room) is one of the measures to prevent airborne diseases (such as SARS-CoV-2).

This study led our research to investigating whether one can obtain information on the density of people by measuring the level of TVOC in a room. This was performed by developing a dual monitoring system based in IoT and air quality sensors that acquire data in regard with temperature,

humidity, TVOC and eCO₂. The test results presented in this paper conduct one to the following ideas:

- Monitoring the TVOC level (and implicitly the pollution level in a room) can be done at a low price with common commercially available components.
- Using IoT techniques one can implement large-scale monitoring systems.
- By controlling the sources of artificial VOCs (chemicals, tobacco products, heating by combustion) one can determine the density of people in a room.
- If one can determine the density of people in a room, one can assess the risk of spreading airborne diseases.

Given the legislative constraints during the period of performing the tests, we could not establish larger scale settings in order to define a precise method of assessing the number of people in a room in any situation. However, we obtained a proof of concept for assessing the risk of spreading airborne diseases. Further research and development of the dual monitoring system will be focused on:

- Warning modules to help one overcome the level of pollution in a room.
- Warning modules for exceeding a certain number of people in a room and for indicating the risk of spreading COVID-19 in a room.

REFERENCES

- [1] Nag PK. Sick Building Syndrome and Other Building-Related Illnesses. Office Buildings. 2018;53-103. Published 2018 Aug 18. doi:10.1007/978-981-13-2577-9_3
- [2] Saini, J., Dutta, M. & Marques, G. A comprehensive review on indoor air quality monitoring systems for enhanced public health. *Sustain Environ Res* 30, 6 (2020). <https://doi.org/10.1186/s42834-020-0047-y>
- [3] Umweltbundesamt. Beurteilung von Innenraumluftkontaminationen mittels Referenz- und Richtwerten. *Bundesgesundheitsbl.* 50, 990-1005 (2007). <https://doi.org/10.1007/s00103-007-0290-y>
- [4] T. Tuomi, S. Vainiotalo, The guideline and target values for total volatile organic compound concentrations in industrial indoor environments in Finland, *Indoor and Built Environment* 2016, Vol. 25(2) 424-434, DOI: 10.1177/1420326X14554270
- [5] Z. Wang, J. Cao, H. Cai and L. Chen, "Study on Indoor Air Quality Characteristics and Air Contaminants Control Strategies in Urban Residential Environment in Xi'an," 2009 3rd International Conference on Bioinformatics and Biomedical Engineering, Beijing, 2009, pp. 1-6, doi: 10.1109/ICBBE.2009.5163478.
- [6] Goldin LJ, Ansher L, Berlin A, et al. Indoor air quality survey of nail salons in Boston. *J Immigr Minor Health.* 2014;16(3):508-514. doi:10.1007/s10903-013-9856-y
- [7] J. Chen and W. Shao, "The Indoor Air Quality of Karaoke Club's Hall and Box," 2018 IEEE International Conference on Advanced Manufacturing (ICAM), Yunlin, 2018, pp. 338-341, doi: 10.1109/AMCON.2018.8614988.
- [8] Oh, H.J., Sohn, J.R., Roh, J.S. et al. Exposure to respirable particles and TVOC in underground parking garages under different types of ventilation and their associated health effects. *Air Qual Atmos Health* 13, 297-308 (2020). <https://doi.org/10.1007/s11869-020-00791-0>
- [9] Hori H, Ishimatsu S, Fueta Y, Ishidao T. Evaluation of a real-time method for monitoring volatile organic compounds in indoor air in a Japanese university. *Environ Health Prev Med.* 2013;18(4):285-292. doi:10.1007/s12199-012-0319-1
- [10] Lin, S., Lu, Y., Lin, Z. et al. Identifying and evaluating school environmental health indicators. *Environ Sci Pollut Res* 27, 16624-16639 (2020). <https://doi.org/10.1007/s11356-020-08092-w>

- [11] Lin S, Lawrence WR, Lin Z, Francois M, Neamtii IA, Lin Q, Csobod E, Gurzau ES. Teacher respiratory health symptoms in relation to school and home environment. *Int Arch Occup Environ Health*. 2017 Nov;90(8):725-739. doi: 10.1007/s00420-017-1235-x. Epub 2017 Jun 9. PMID: 28600748.
- [12] Kumar A, Singh BP, Punia M, Singh D, Kumar K, Jain VK. Assessment of indoor air concentrations of VOCs and their associated health risks in the library of Jawaharlal Nehru University, New Delhi. *Environ Sci Pollut Res Int*. 2014 Feb;21(3):2240-2248. doi: 10.1007/s11356-013-2150-7. Epub 2013 Sep 18. PMID: 24046229.
- [13] P. Lasomsri, P. Yanbuaban, O. Kerdpoca and T. Ouypornkochagorn, "A Development of Low-Cost Devices for Monitoring Indoor Air Quality in a Large-Scale Hospital," 2018 15th International Conference on Electrical Engineering/Electronics, Computer, Telecommunications and Information Technology (ECTI-CON), Chiang Rai, Thailand, 2018, pp. 282-285, doi: 10.1109/ECTICon.2018.8619934.
- [14] Ren Y, Li L, Jia YM. New Method to Reduce COVID-19 Transmission - The Need for Medical Air Disinfection is Now. *J Med Syst*. 2020 May 21;44(7):119. doi: 10.1007/s10916-020-01585-8. PMID: 32440893; PMCID: PMC7241285.
- [15] Chanjuan Sun, Zhiqiang Zhai, The efficacy of social distance and ventilation effectiveness in preventing COVID-19 transmission, *Sustainable Cities and Society*, Volume 62, 2020, 102390, ISSN 2210-6707, <https://doi.org/10.1016/j.scs.2020.102390>.
- [16] Azuma, K., Yanagi, U., Kagi, N. et al. Environmental factors involved in SARS-CoV-2 transmission: effect and role of indoor environmental quality in the strategy for COVID-19 infection control. *Environ Health Prev Med* 25, 66 (2020). <https://doi.org/10.1186/s12199-020-00904-2>
- [17] Borisova T, Komisarenko S. Air pollution particulate matter as a potential carrier of SARS-CoV-2 to the nervous system and/or neurological symptom enhancer: arguments in favor. *Environ Sci Pollut Res Int*. 2020 Oct 13:1-7. doi: 10.1007/s11356-020-11183-3. Epub ahead of print. PMID: 33051841; PMCID: PMC7552951.
- [18] Masoumbeigi H, Ghanizadeh G, Yousefi Arfaei R, Heydari S, Goodarzi H, Dorostkar Sari R, Tat M. Investigation of hospital indoor air quality for the presence of SARS-Cov-2. *J Environ Health Sci Eng*. 2020 Sep 30;18(2):1-5. doi: 10.1007/s40201-020-00543-3. Epub ahead of print. PMID: 33014385; PMCID: PMC7525766.
- [19] Fareed, Z., Iqbal, N., Shahzad, F., Shah, S., Zulfiqar, B., Shahzad, K., Hashmi, S. H., & Shahzad, U. (2020). Co-variance nexus between COVID-19 mortality, humidity, and air quality index in Wuhan, China: New insights from partial and multiple wavelet coherence. *Air quality, atmosphere, & health*, 1-10. Advance online publication. <https://doi.org/10.1007/s11869-020-00847-1>
- [20] Di Girolamo, P. Assessment of the potential role of atmospheric particulate pollution and airborne transmission in intensifying the first wave pandemic impact of SARS-CoV-2/COVID-19 in Northern Italy. *Bull. of Atmos. Sci.& Technol.* (2020). <https://doi.org/10.1007/s42865-020-00024-3>
- [21] Patel, K. P., Vunnam, S. R., Patel, P. A., Krill, K. L., Korbitz, P. M., Gallagher, J. P., Suh, J. E., & Vunnam, R. R. (2020). Transmission of SARS-CoV-2: an update of current literature. *European journal of clinical microbiology & infectious diseases* : official publication of the European Society of Clinical Microbiology, 39(11), 2005-2011. <https://doi.org/10.1007/s10096-020-03961-1>
- [22] ESP8266 Wi-Fi MCU Espressif Systems (last accessed January 25, 2021) <https://www.espressif.com/en/products/socs/esp8266>
- [23] Adafruit Feather Huzzah with ESP8266 (last accessed January 25, 2021) <https://www.adafruit.com/product/2821>
- [24] HTU21D(F) Sensor Digital Relative Humidity sensor with Temperature output (last accessed January 25, 2021) https://cdn-shop.adafruit.com/datasheets/1899_HTU21D.pdf
- [25] CCS811 (last accessed January 25, 2021) <https://www.sciosense.com/products/environmental-sensors/ccs811-gas-sensor-solution/>
- [26] A. J. Alabdullah, B. I. Farhat and S. Chtourou, "Air Quality Arduino Based Monitoring System," 2019 2nd International Conference on Computer Applications & Information Security (ICCAIS), Riyadh, Saudi Arabia, 2019, pp. 1-5, doi: 10.1109/CAIS.2019.8769529.
- [27] R. N. Pietraru, L. Gabriela Zegrea and A. D. Ionita, "Publish-Subscribe Deployment Alternatives for Scenarios Related to University Laboratory Safety," 2019 11th International Symposium on Advanced Topics in Electrical Engineering (ATEE), Bucharest, Romania, 2019, pp. 1-6, doi: 10.1109/ATEE.2019.8724923.
- [28] J. Lozano et al., "Personal electronic systems for citizen measurements of air quality," 2019 5th Experiment International Conference (exp.at'19), Funchal (Madeira Island), Portugal, 2019, pp. 315-319, doi: 10.1109/EXPAT.2019.8876471.
- [29] Saini, J., Dutta, M. & Marques, G. Sensors for indoor air quality monitoring and assessment through Internet of Things: a systematic review. *Environ Monit Assess* 193, 66 (2021). <https://doi.org/10.1007/s10661-020-08781-6>
- [30] ThingsBoard Open-source IoT Platform (last accessed January 25, 2021) <https://thingsboard.io/>
- [31] G. Varzaru, A. Zarnescu, R. Ungurelu and M. Secere, "Dismantling the confusion between the equivalent CO2 and CO2 concentration levels," 2019 11th International Conference on Electronics, Computers and Artificial Intelligence (ECAI), Pitesti, Romania, 2019, pp. 1-4, doi: 10.1109/ECAI46879.2019.9042113.