

A Cost Effective UV Robot for Disinfecting Hospital and Factory Spaces for Covid-19 and Other Communicable Diseases

Md. Mushfiqur Rahman Saad and Md. Abdur Razzak
Department of Electrical and Electronic Engineering
Independent University, Bangladesh

Plot-16, Block-B, Aftabuddin Ahmed Road, Bashundhara R/A, Dhaka-1212, Bangladesh
E-mail: mushfiq1996@gmail.com, razzak@iub.edu.bd

Abstract—This paper presents a cost effective UV robot for applications of disinfecting hospital and factory spaces from Covid-19 and other communicable diseases. This is based on a disinfection method using a remotely controlled Ultra-Violet (UV) disinfection robot. The robot is equipped with 3 UVC lamps in a 360 degree beam coverage setting, on a mobile base which is equipped with motors, controllers and sensors that allow the lamps to move around and disinfect surfaces with ease. The robot can automatically detect human and or other types of non-living presence over which machine learning models are built that allows for some degree of autonomous control. Its main control unit is operated via WiFi using the mobile as a transceiver device allowing for remote safe control of UVC lamp disinfection.

Keywords—Covid-19, Ultraviolet, UVC Lamp, Disinfection, UV, Robot.

I. INTRODUCTION

The years 2019-2020 has posed one of the greatest challenges of the 21st century with one of the deadliest communicable viruses which has taken up the shape of a global pandemic at the most crowded moment in Earth's history. The SARs COV-2 virus, a reiteration of MARS and SARS virus found in the earlier years, was first noticeably discovered at an exotic meat market in Wuhan, China, since which this has caused millions of deaths worldwide and thousands of death in Bangladesh [1-2]. Following trends of globalization, fast moving economies and fast exchange of people across various locations the virus spread to a few million people in a matter of months. The world was put to a halt, workspaces had to shut down and economies and daily lives were directly put on track for a halt. As different front liners around the world fought for human lives and prosperity, things started to look up when countries started to slowly open their institutions back up again. But a year down the line we still face great imminent threat of mass mortality and economic and financial loss from the aftermath of this ongoing pandemic. In a country like Bangladesh with extremely limited access to alternate sources of income and other resources, most people from Bangladesh's society has to get back to work willingly or unwillingly [2].

This amplifies the threat under such circumstances especially since Bangladesh's economy is driven by crowd rearing businesses like factories and garments. It is almost impossible for a garment worker or a factory worker to not attend their job. On the other hand, factories and similar institutions don't often take the mandatory health precautions

required to fight the pandemic. The number one problem identified in this paper's background research is that most of these places act as avenues for cross contamination. This exposes people who already have little access to quality healthcare, to become ill and even face death. To help reduce this effect this project was created towards building a disinfecting robot which could be remotely operated with little to no maintenance and with only a main onetime cost and no recurring overheads. This is why the method of UV lights was chosen to help disinfect public spaces that could be expanded to any form of public space with minimal cost and be used to disinfect the space without using spraying equipment or reagents [3-5].

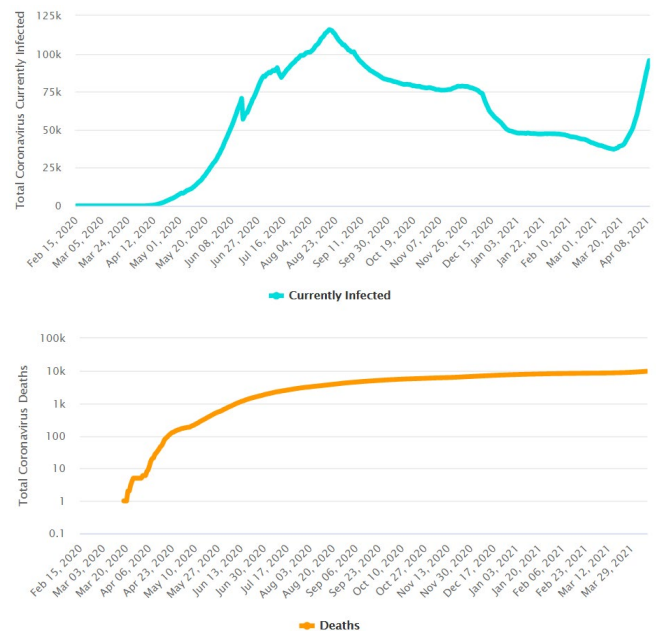

Fig.1 Total currently infected (above) and total deaths in logarithmic scale (down) in Bangladesh [2]

Currently there are lots of disinfection methods [6-8] as recommended by the World Health Organization and Center for Disease Control (WHO & CDC). The most commonly used disinfectants are isopropyl alcohol (>70%), bleach and hydrogen peroxide. All these disinfectants come in the form of solutions or aerosolized sprays which can be administered over specific surfaces. But they pose multiple issues. Since most of these disinfectants are liquids they cannot be used everywhere especially to clean factory or industry surfaces.

Secondly bleach and hydrogen peroxide are reactive and corrosive to a large extent, which means their use on office/factory equipment is strictly limited and especially limited to be used with other cleaning products which might react adversely. They also pose substantive health risks when used in aerosolized or other forms especially in settings such as within hospitals [8]. This creates a unique challenge where most of these liquid based solutions cannot be administered for example in garment factories where the end products would be ruined. Moreover, their recurring overhead cost also poses significant financial trouble as a lot of these solutions are required to even disinfect a relatively small space. So the choices of UV lights were made which would be mounted on a mobile platform which could move around autonomously.

This paper presents the design of an effective disinfection robot that can sanitize regularly used spaces tangibly and perform similarly to other disinfection methods such as spraying or fogging with chemically active reagents. The lamps' intensity is chosen accordingly to be classified germicidal and the robot parameters such as speed, safety and spatial awareness are mapped out for design of an effective pandemic fighter.

This design requires an aspect of product design and a mapped out thought process. During design, the speed, orientation and object detection of the base of the robot are considered. The robot is designed efficiently to work on all types of terrain and especially on factory floors, some of which might be very slippery. The UV lights are placed for maximum coverage (360 degrees) whilst ensuring that no human contact is made during the design, testing or application phase of the designed robot.

II. PROPOSED UVC DISINFECTION SYSTEM

The proposed system which consists of a few components and modules as outlined in the block diagram shown in Fig.2.

The center of the system is the Arduino based esp32 cam module which is the brain of the operation. A battery powers the UV lights through a modified sine wave inverter using a relay as the control. The ESP32 unit also controls two L298 motor drivers that in turn control 4 motors using Pulse Width Modulation (PWM) speed control. An optional distance sensor is placed to add object avoidance.

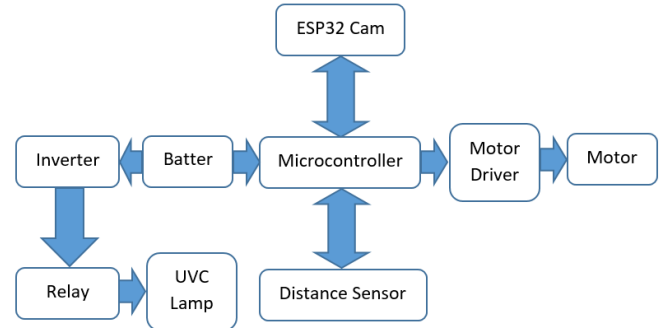
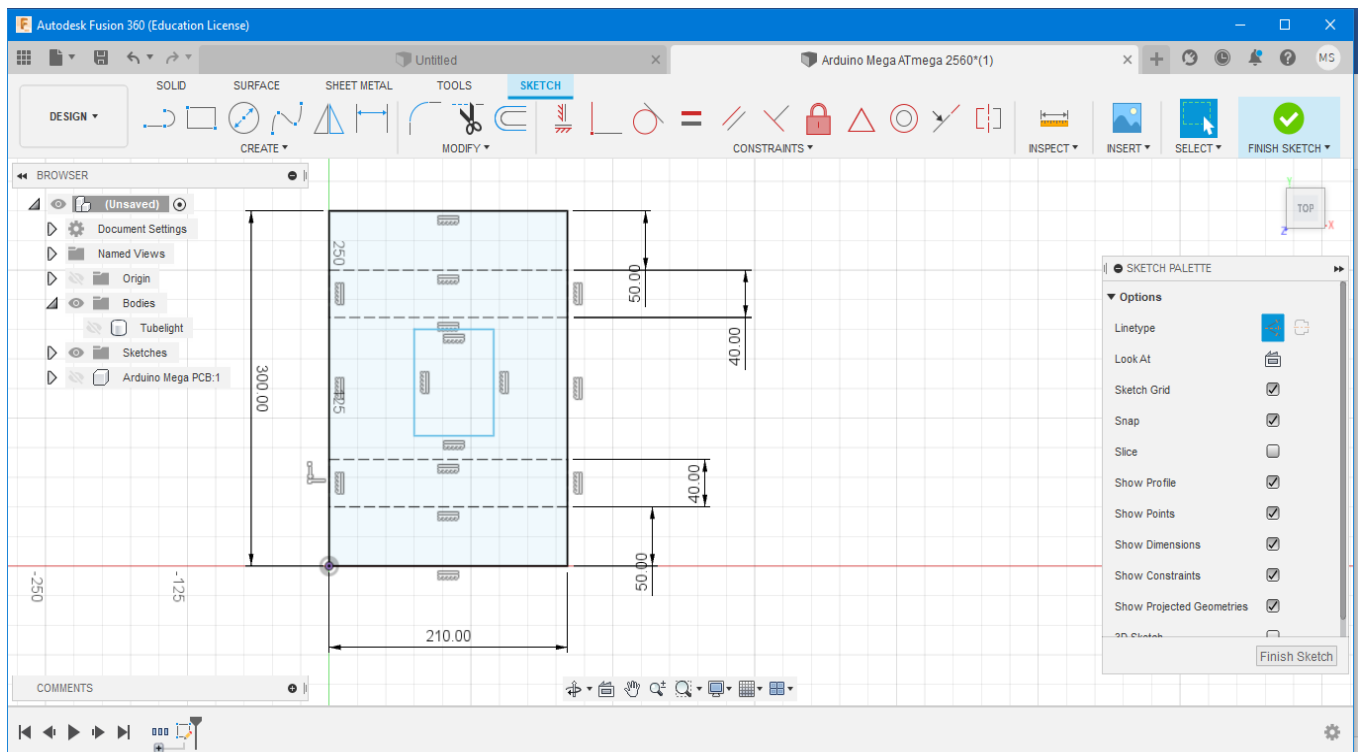

Fig. 2: Block diagram of proposed system

The UVC robot was implemented via 3D designing on Fusion360 which is open source 3D CAD design software as shown in Fig.3. During design many parameters are considered in choosing the proper dimensions of all parts of the design, especially considering the 3D printing time which was a prime optimization and consideration factor. The designed CAD model featured compartments to securely hold all components such as the batteries, microcontroller and so on. Moreover the top of the base is specifically designed to hold the UVC lights in a full beam coverage array. On the top an esp32 cam holder was designed which could hook onto the latch and provide video feedback from the front of the robot. The 3D design has been created with parametric settings, and future scalability is possible simply by changing the parameters within the design window.



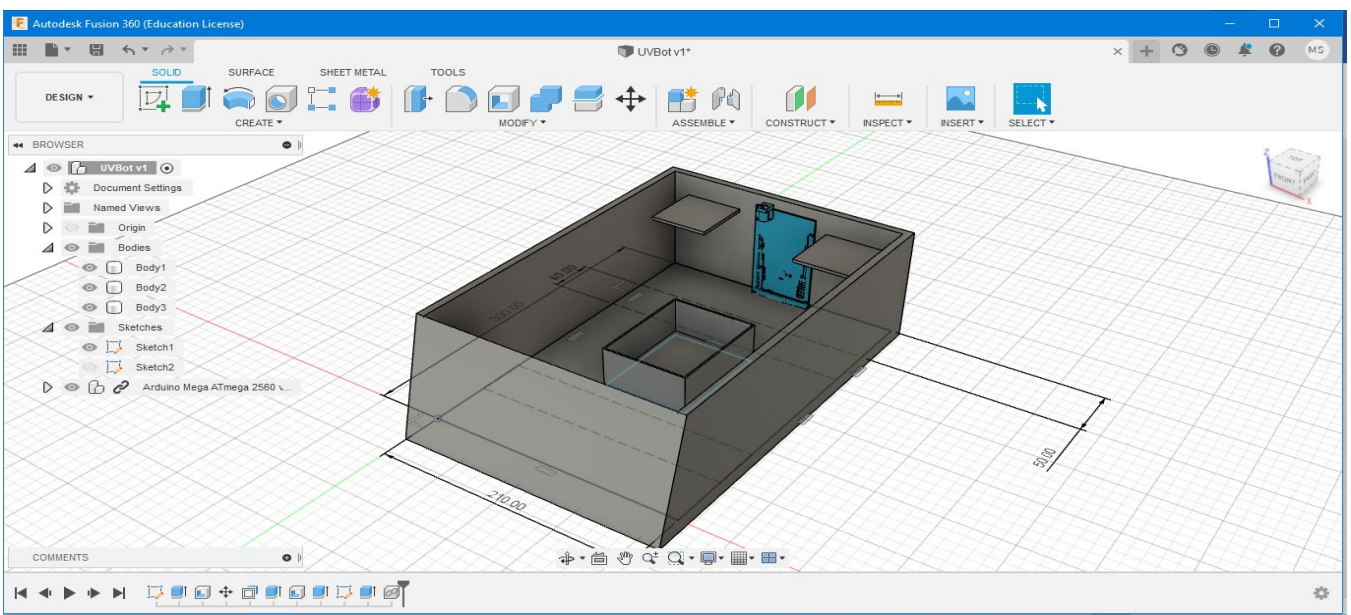
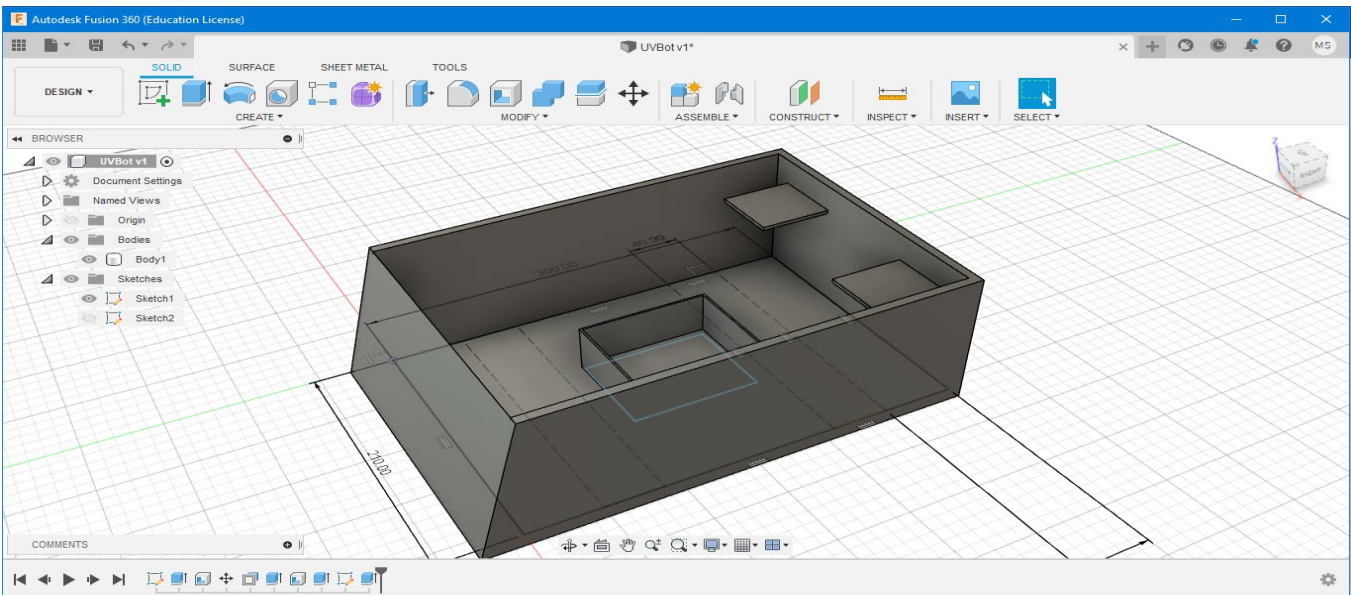
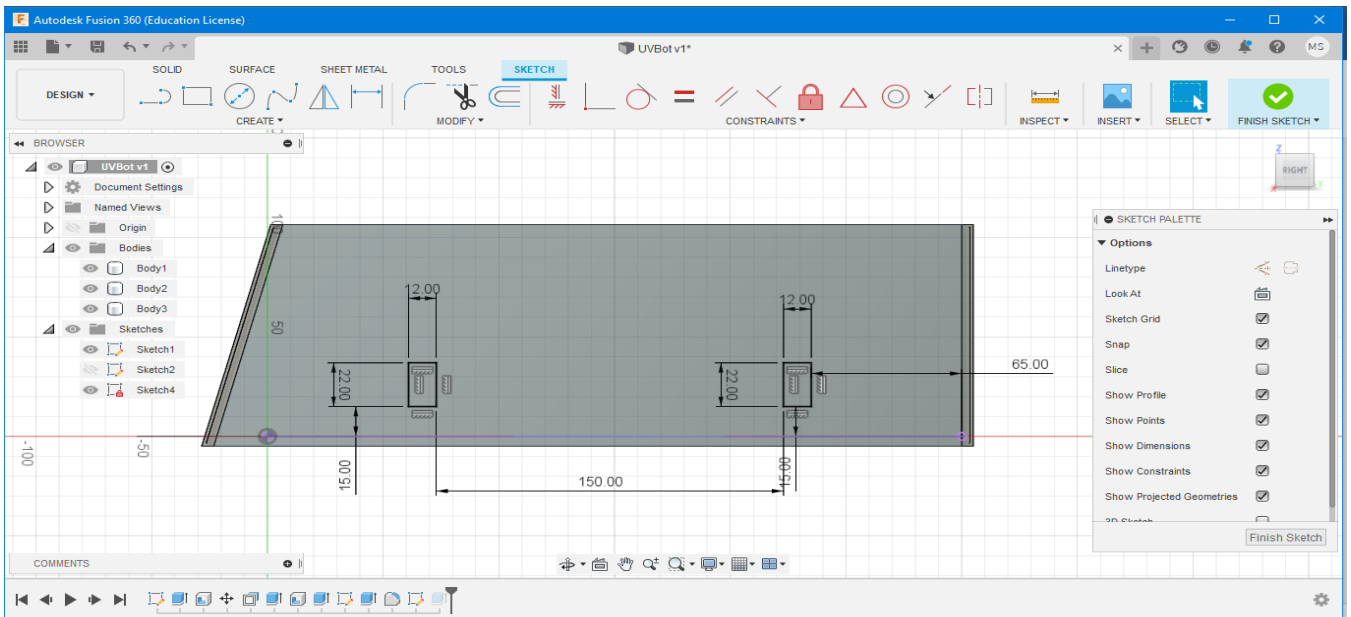

Fig.3 3D design of mobile base of robot

In the diagrams shown in Fig. 3, it can clearly be seen how the 3D design was conducted especially by placing CAD models of the hardware used (i.e Arduino) and then creating sufficient spaces to make sure everything would fit neatly inside the mobile base of the robot.

III. HARDWARE PROTOTYPE AND TESTING

A. Hardware Requirement

The hardware component of the UVC robot and their purpose is listed in Table I. The pin to pin diagram of ESP32 with FTDI for programming is shown in Fig. 4.

Table I. list of hardware component

Component Name	Purpose
ESP32 Cam	Camera Feedback and WIFI Control
Gear Motor	300 rpm gear motor for moving base
120W Inverter	To convert the DC Battery voltage to AC to run UV lights
9Ah 12V SLA Battery (6Vx2)	Main power source of the system
Relay Module (5V)	To turn the UV light on by the Arduino
L298 Motor Driver	To control the motors (should be replaced by BTS)
Sonar Distance Sensor	To check for human to bot distance
3D Printed Body	Main casing for all hardware
40W UV Light	Emitting light for disinfecting hospitals and factory spaces
UV Light Sensor	To detect proper wavelength of UV Light

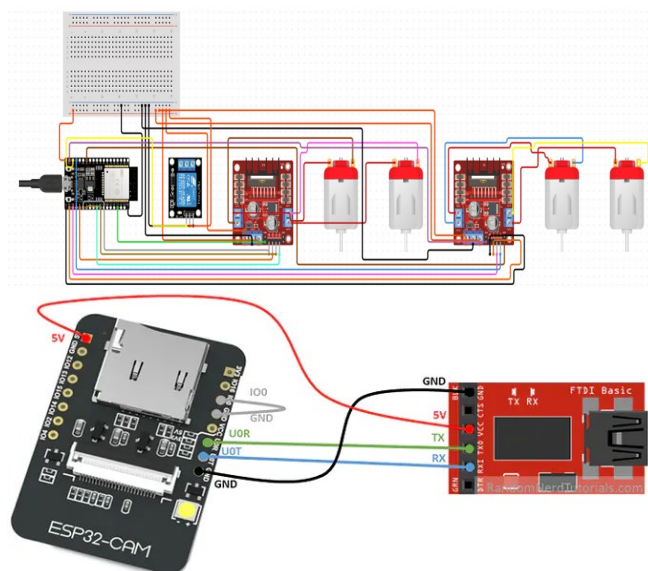

Fig. 4: Pin to pin diagram of ESP32 with FTDI for programming

B. UV Light Detection

The UV light detection module is one of the most important aspects of the hardware. To ensure proper germicidal behavior it needs to ensure the proper wavelength of the lights being used to match with manufacturer claims. The UV detection module which can detect up to 250nm detected the lowest value indicating the light intensity was as claimed by the manufacturer. However, there was another easy test to check the UVC light. A small piece of glass was

put in front of the sensor and the light to see if the value changed [9]. Because UVC light is fully blocked with the glass, changes in value with and without the glass indicated the presence of UVC light in an alternately assuring way. After the light was quality checked and ensured, the 3D printed parts of the body was assembled with all the hardware as per the system block diagram setup for testing.

C. Software Development

The software used here is an open source software already designed for android under the name of esp32 cam. The esp32 cam software was modified to allow for object tracking, detection, control and direct video feedback. The screenshot from the modified mobile application software is shown in Fig.5.



Fig. 5 Software screenshot

From the screenshot it is seen that the app allows for multiple control interfaces. The video feedback is put in the middle and the arrow keys allow for navigation of the robot. The esp32 cam also has built in future support to install a pan-tilt servo interface for better video monitoring. The robot can be put into both object tracking and line following modes depending on the environment and it can compute the images using artificial intelligence algorithms which are processed on the user's phone [10]. The interface is intentionally kept clean to allow for use of this device by any untrained personnel within a few tries. Future additional speed and other types of control can be added for better maneuverability.

The software functions were developed in Arduino IDE and Android Studio, respectively, to properly pair the hardware with mobile phones and assure connectivity.

During the software development process, the use of OPENCV library was critical. This readily available library allowed for quick deployment of a machine learning algorithm which was able to readily recognize objects, faces etc. with a little bit of tweaking, and even from the low resolution output of the video system installed. The big challenge of the development was deploying these relevant packages within an android studio web app since the software runs an IP Address based HTML script within itself where all the buttons and everything is put there as HTML objects.

D. Development of Hardware Prototype and Testing

The final hardware prototype was built based on the design presented in previous subsections and tested successfully as shown in Fig. 6. The hardware for this project was developed and tested with certain key parameters in mind. These were especially important during testing. Here are the outlined testing parameters considered for this robot:

- UVC Light wavelength: The UVC light had to irradiate wavelengths less than or equal to the 250-260 nm mark to be considered germicidal.
- The motion sensing mechanism on the esp32 cam had to work instantaneously to shut down in the presence of any human beings; this process had to be fast and error proof.
- Unobstructed emergency shut off functions should be able to work under any circumstances allowing remote shutdown in cases of emergency.
- The motor functions needed to be PID tuned and had to allow for differential speed control to allow steering less navigation.
- Since for a small base a big battery could not be used, inverter had to be carefully picked (or better designed) to assure longer battery performance of at least an industry standard of 5 hours of operation

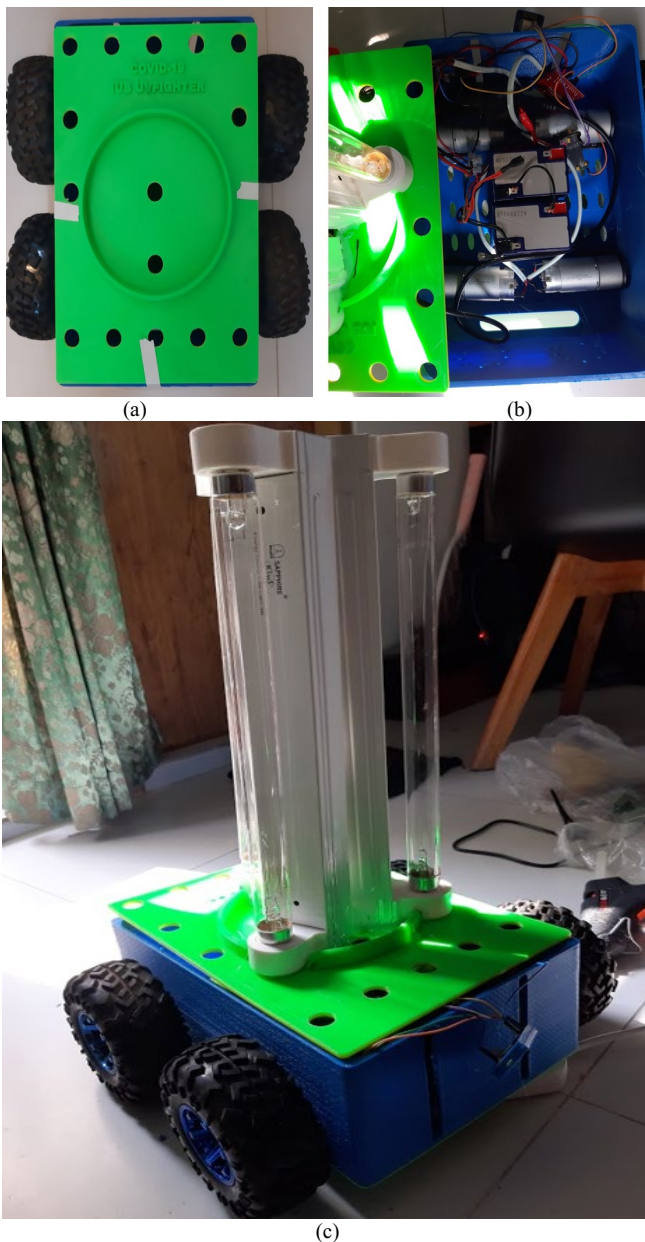

Fig. 6 (a) Mobile base of robot (b) Controller for robot circuit and controller (c) Complete hardware prototype of the designed UV robot

Using these parameters, the UVC disinfection robot was put to the test. The safety features were some of the most important features on this germicidal robot and close monitoring and evaluation was done especially on those aspects. The 3D printed base and cover had some important design features built into it as well. The printed body was made light weight yet durable and created from a form of 3D printing filament known as PLA which does not react too adversely with UV light exposure causing any form of deformation or degradation. Once the robot was assembled it was tested on slippery floors trying to emulate epoxy raisin floors commonly found in factory or hospitals to check for traction and speed control. UVC beam coverage was then measured with UV light sensors placed very close to the machine in its path to check and verify that at least 80% beam coverage could be ensured in this configuration. Functions regarding the UV light including auto shutdowns and detections of humans using dummies was tested to satisfactory completion.

IV. RESULTS AND ANALYSIS

From the experimental setup it was observed that the robot successfully linked with the mobile phone app with ease and could be controlled remotely as also indicated in previous screenshots of the software shown in Fig.5. One key challenge was that both the mobile and the device had to be connected to the same wireless network and this created some problems in the remote connectivity of the device. However, the robot worked at the desired pace emitting a fully surrounded UV light beam. The implementation cost of the proposed UVC disinfection robot and cost comparison with different disinfection methods for a space area of 10000 sq. ft. is tabulated in Table II and III, respectively, which confirms the viability and feasibility of the project.

Table II Cost analysis as compared to other disinfection types

Name	Specification	Quantity	Cost (BDT)
UV robot		1	10,000
UVC lamp	10W	4	2,000

Table III Cost comparison with different disinfection methods for a space area of 10000 sq. ft.

Disinfection type	Advantages	Disadvantages	Approx. cost of disinfection per day (BDT)
Isopropyl alcohol	Readily available	Expensive (does not work diluted), cannot controlled remotely	2500 (include spraying mechanism and 5 litre dispensing)
Bleach / Hydrogen peroxide	Readily available	Expensive (does not work diluted), cannot controlled remotely	500 using had sprayer
UV robot	Portable and remotely controlled	Initial cost is a bit high	30 per day based on 4-5 hours operation

The core strengths and weaknesses of this system is described in Table III. This system is not only cost effective but in the long run feasible for use across factories with minimum overhead costs and minimum user input. This is

also suitable for places that require disinfection without destroying office / company furniture or machinery which would be a problem with relevant disinfectant solutions. Moreover, the health and well-being promoted through the device would itself pay for the device in a very short span of time as compared to the one-time cost of acquiring the device.

In similar project designs around the world the efficacy of the UVC lights have been tested. Due to limitations of lab facilities, the lab tested for germicidal action could not be possible.

The UVC robot can be a great tool to disinfect public spaces because (1) it requires a small investment for long term savings, (2) it consumes very little energy and has a low charging time making it an energy efficient device, (3) it can be readily used in spaces where spraying chemical reagents might harm the end-products or humans involved, (4) it has a long life-span which allows for it to be economically viable, (4) it has multiple safety features to provide automatic shutdown alongside human and object detection and tracking (5) it can provide a long battery backup with its 9Ah battery pack.

This UV robot is a sustainable form of disinfection which can be used beyond the scope of COVID-19 to tackle workplace safety issues. For example, UV based devices have been for long term used for Hospital Acquired Infections (HAI). In the long run with more research and more calibrated UV disinfection robots, hospitals can be cleared of infectious material which can cause HAIs. This can save hospitals money and mortality. In the current setup of the designed robot has been designed as a rugged vehicle to tackle factories and especially garment floors where it can sanitize effectively the regularly used surfaces for thousands of workers and potentially save more than a million lives. The technology can be expanded with code to run on factory floors completely autonomously. This will further reduce human input and allow for better automated control when no humans are present. The esp32 cam module can be upgraded with both firmware and better hardware for excellent feedback and allow for better machine learning models [10].

The machine learning algorithm can be trained with some input data to understand its environment better and run test cases to improve its security features [11]. More work can also be done on the UV light beam design by increasing the number of UV lights and using better UVC LED lamps instead of mercury lamps. This would mean that the system would be significantly more energy efficient and would completely avoid the loss of the inverter by running as a complete DC system with the UVC LED lights. The top lid has room to have a servo fitted system to give angular control

to the top lid for better beam coverage of the entire system. There are huge incremental steps to be taken in efficient motor control for better power efficiency of the system and the system overall. But this system for now proves to be a worthy disinfection agent solving an expensive problem for thousands of people.

V. CONCLUSION

A cost-effective UVC robot has been designed and developed aiming to disinfect hospitals and factory spaces against Covid-19 and similar communicable diseases. It can be clearly seen that the robot emits UVC light as per the initial tests with the UV light detection module and manufacturer datasheet details. Bacterial colonies could not be positively tested at a lab due to limitations of resources which will be reported and presented somewhere else in near future.

REFERENCES

- [1] Islam MT, Talukder AK, Siddiqui MN, Islam T., "Tackling the COVID-19 pandemic: The Bangladesh perspective", *J Public Health Res.* 2020; 9(4):1794.
- [2] <https://www.worldometers.info/coronavirus/country/bangladesh/> accessed on April 9, 2021.
- [3] F. A. Juarez-Leon, A. G. Soriano-Sánchez, M. A. Rodríguez-Licea and F. J. Perez-Pinal, "Design and Implementation of a Germicidal UVC-LED Lamp," *IEEE Access*, vol. 8, pp. 196951-196962, 2020. Guettari M, Gharbi I, Hamza S. UVC disinfection robot [published online ahead of print, 2020 Oct 14]. *Environ Sci Pollut Res Int.* 2020;1-6.
- [4] Blue Ocean Robotics. (2018). Evaluation of the UV-Disinfection Robot. <https://prhoinsa.com/images/pdf/uvd/UVDR-Whitepaper.pdf>.
- [5] Casini B, Tuvo B, Cristina ML, et al., "Evaluation of an Ultraviolet C (UVC) Light-Emitting Device for Disinfection of High Touch Surfaces in Hospital Critical Areas," *Int J Environ Res Public Health.* 2019;16(19):3572. Published 2019 Sep 24.
- [6] Panda, N. Dey and D. Samantaray, "Design and development of a cost-efficient Air Sterilization System," 2010 International Conference on Systems in Medicine and Biology, Kharagpur, India, 2010, pp. 376-380.
- [7] Hawley B, Casey M, Virji MA, Cummings KJ, Johnson A, Cox-Ganser J., "Respiratory Symptoms in Hospital Cleaning Staff Exposed to a Product Containing Hydrogen Peroxide, Peracetic Acid, and Acetic Acid," *Ann Work Expo Health.* 2017;62(1) 28-40.
- [8] Boyce, J. M., "Modern technologies for improving cleaning and disinfection of environmental surfaces in hospitals", *Antimicrob Resist Infect Control* 5, 10 (2016).
- [9] Duarte, Ida & Rotter, Anita & Malvestiti, Andrey & Hafner, Mariana, "The role of glass as a barrier against the transmission of ultraviolet radiation: An experimental study", *Photodermatology, photoimmunology & photomedicine.* 25. 181-4 (2009).
- [10] Dokic K. (2020) Microcontrollers on the Edge – Is ESP32 with Camera Ready for Machine Learning? In: El Moataz A., Mammass D., Mansouri A., Nouboud F. (eds) *Image and Signal Processing. ICISP 2020. Lecture Notes in Computer Science*, vol 12119. Springer, Cham.
- [11] J. Bai, S. Lian, Z. Liu, K. Wang and D. Liu, "Deep Learning Based Robot for Automatically Picking Up Garbage on the Grass" in *IEEE Transactions on Consumer Electronics*, vol. 64, no. 3, pp. 382-389, Aug. 2018.