

# COVID-19 Recognition Based on Patient's Coughing and Breathing Patterns Analysis: Deep Learning Approach

Lazhar Khriji, Ahmed Ammari  
Sultan Qaboos University  
Muscat, Oman  
{lazhar, chiheb}@squ.edu.om

Seifeddine Messaoud, Soulef Bouaafia, Amna Maraoui, Mohsen Machhout  
Monastir University  
Monastir, Tunisia  
{seifeddine.messaoud, soulef.bouaafia, amna.maraoui, mohsen.machhout}@fsm.rnu.tn

**Abstract**—The World Health Organization has declared that the new Coronavirus disease (Covid-19) has become a pandemic since March 2020. It consists of an emerging viral infection with respiratory swelling that can progress to atypical pneumonia. In fact, experts stress the early detection importance of those infected with COVID-19 virus. In this way, the infected patients will be isolated from others, and then prevent the virus spread. However, prompt assessment of breathing patterns is important for many medical emergencies. We present, in this paper, a deep learning technique-based COVID-19 cough and breath analysis that can recognize positive COVID-19 cases from both negative and healthy COVID-19 cough and breath recorded on smartphones or wearable sensors. Firstly, audio signals, as well as cough and breath, will be preprocessed to remove noise. After that, deep features will be extracted using the deep Long Term Short Memory (LSTM) model. Finally, the recognition step will be performed exploiting extracted audio features. Numerical results prove the efficiency of the proposed deep model in terms of high accuracy level and low loss value compared to the other techniques.

## I. INTRODUCTION

The new coronavirus disease COVID-19, appeared at the end of December 2019 in Wuhan city of China, has affected most countries around the world [1] [2]. COVID-19 is caused by SARS-COV2 and represents the causative agent of a potentially fatal disease which is a global public health concern. In this context, person-to-person COVID-19 infection transmission led to the isolation of patients that were subsequently administered a variety of treatments. In general, COVID-19 is an acute resolved disease, but it can also be fatal, with a high fatality rate.

The most common symptoms of COVID-19 are fatigue, dry cough, and fever. Other symptoms include joint pain, shortness of breath, gastrointestinal symptoms, muscle pain, and loss of smell or taste [3]. At the writing time, there are 109 million active cases of COVID-19 globally, and there have been 2.4 million deaths in the world [4]. The pandemic scale has caused some health systems to bypass the need for testing and case management.

Several efforts have been made to identify COVID-19's precocious symptoms by exploiting artificial intelligence techniques and medical images [5], [6]. In this context, the deep

Convolutional Neural Network Architecture 'Resnet 50' has been shown to perform better than other pre-trained models such as GoogLeNet, VGG16, and AlexNet in COVID-19 recognition tasks. However, Resnet50 is used, in [7], to detect COVID-19 from computed tomography (CT) images with an accuracy of 96.23%. The same architecture for detecting COVID-19 was shown, proposed in [8], an accuracy of 96.7% and for detecting COVID-19 from X-ray images an accuracy of 96.30% [9]. Authors in [10] proposed a DNN to detect COVID-19 from x-ray images by applying the transfer learning approach. Features were extracted from x-ray images using DenseNet121, ResNet18, GoogLeNet, AlexNet and InceptionV3 models. Then the model was added to combine the outputs of all the pre-trained models. The results obtained are about 96.4% accuracy and 99.62% recall. A deep learning system based on Generative Adversarial Network (GAN) with deep transfer learning for coronavirus detection in chest X-ray images [11]. Authors, in [12], proposed a transfer learning with convolutional neural networks technique exploiting X-ray images with the goal is to detect COVID-19. In their work proposed in [13], authors proposed an early recognition model based on a deep learning scheme to recognize Influenza-A viral pneumonia and COVID-19 using medical CT images. In the same context, an efficient deep learning algorithm proposed by the work in [14] to extract features to diagnose before pathogenic tests, with the aim is to save time. In [15], authors also used deep learning techniques to suggest a powerful model to detect COVID-19 from high-resolution medical CT images.

Cough is one of the most COVID-19 predominant symptoms. However, it is also a sign of over 100 other illnesses, while their respiratory system effects vary [16]. It has been told that the glottis behaves depending on pathological conditions [17]. Thus, this makes it possible to differentiate cough caused by asthma [18], tuberculosis [19], whooping cough [20], and bronchitis [21]. In this context, respiratory data as well as coughs, sneezing, breathing, and speech can be addressed by machine learning algorithms with the aim is to recognize the COVID-19's respiratory illness [22]. However, artificial intelligence techniques are eligible to assort COVID-19 from

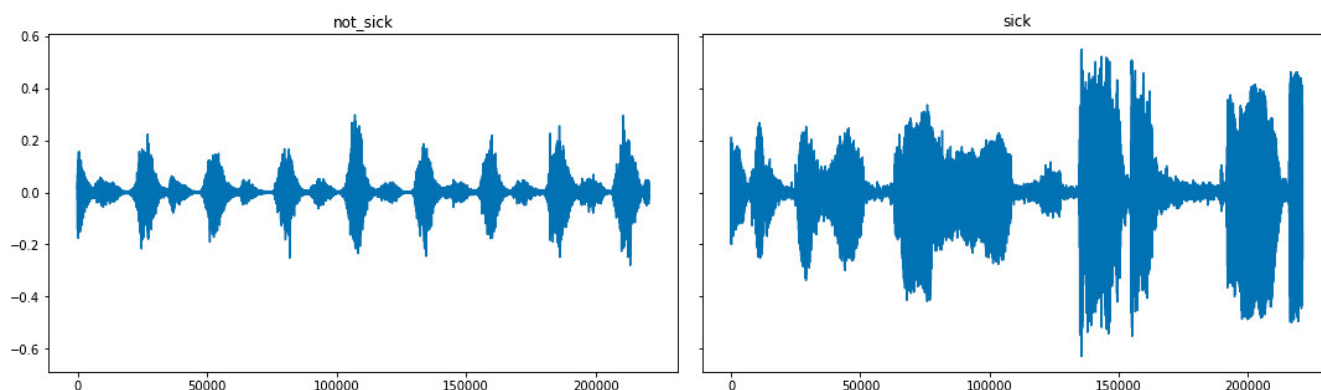

Fig. 1. Example of audio Signal Visualization (Sick and Not Sick)

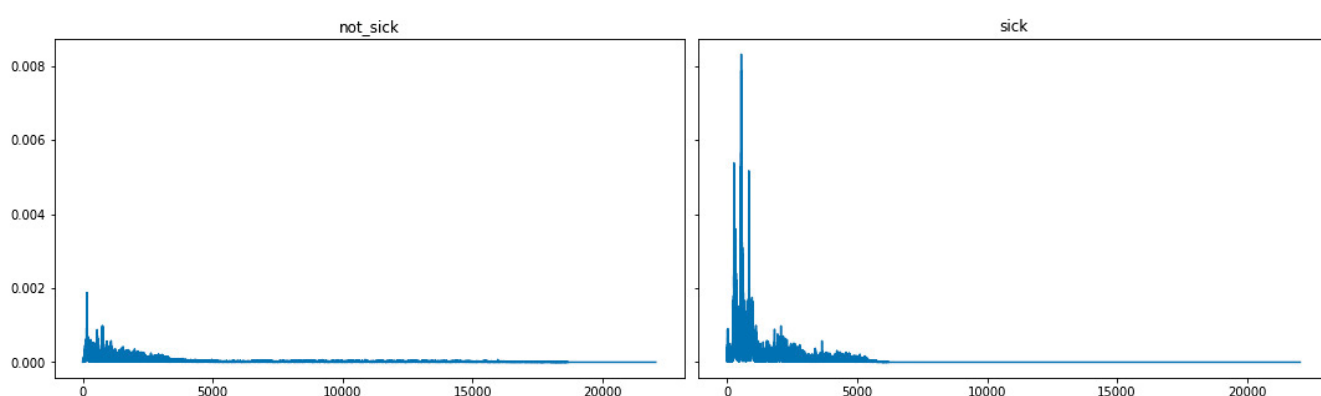

Fig. 2. Amplitude spectrum of signals in Fig. 1

respiratory sounds with an area Under Curve exceeding 0.80 [23]. Thus, a distinction can be made between a cough caused by asthma [18], tuberculosis [19], and COVID-19. Authors proposed, in [24], a deep neural network that recognizes COVID-19 from other coughs with an accuracy of 96.83%. More than that, Resnet18 is exploited to identify COVID-19 from cough signals with an area under curve of 0.72. Where the cough samples were collected via the phone [25]. In the same context, authors, in [26], proposed a deep Resnet50 model to classify COVID-19 coughs, from 4256 samples, that achieved an area under curve of 0.97.

The main contribution of this paper is to propose a deep learning approach based on LSTM network to provide COVID-19 recognition exploiting patient's audio signals as well as Coughing and Breathing. The reminder of this paper is organized as follows: Section II, discuss dataset pre-processing and feature extraction. Section III, the architecture of the proposed deep learning based LSTM tool will be clarified. In section IV, we discuss the simulation results of the proposed scheme. At the end, the conclusion of this paper is provided in section V.

## II. DATASET COLLECTION AND PRE-PROCESSING

Early detection of respiratory tract infections can lead to timely diagnosis and treatment, which can result in better

outcomes and reduce the likelihood of severe complications. Respiratory sounds carry rich information that can be mined to develop automated approaches for behavior sickness detection like coughing and sneezing. The used dataset, in this work, has been produced for the Pfizer Digital Medicine Challenge. It was created using audio files from ESC-50 and AudioSet. The open-source BMAT Annotation Tool was used to annotate this dataset [27].

The public datasets, which contains an audio signal, as well as, cough, sneeze, and breath classified into two classes sick and not sick, is composed of three subsets, including train set (sick (n=1435), not\_sick (n=2283)), validation set (sick (n=468), not\_sick (n=753)), and test set (sick (n=642), not\_sick (n=1012)). This dataset is in original form, which means that signals contain noise. However, before processing data and proceeding with the learning process, audio signals must be pre-processed. In this context, pre-processing theories will be introduced to extract the features before introducing the training and the testing phase. For example, random audio signal visualization in both classes (sick and not sick) are shown in Fig. 1. However, it can be seen that the uninfected (Fig. 1 not\_sick) patient has regular breathing, which indicates the respiratory system and lungs health. While it is not the case for the infected patient (Fig. 1 sick) in which the breathing is

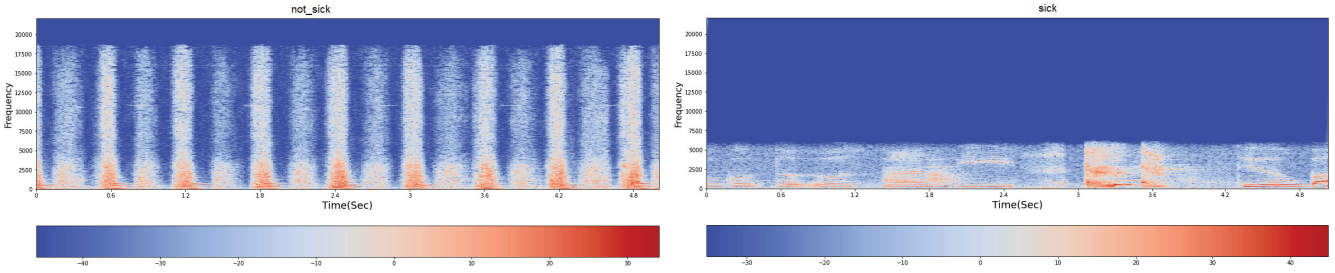

Fig. 3. Power Spectrum

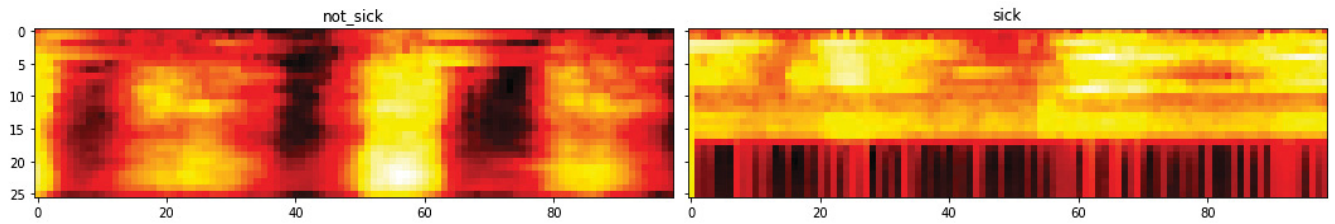

Fig. 4. Filter Bank Coefficient Spectrum

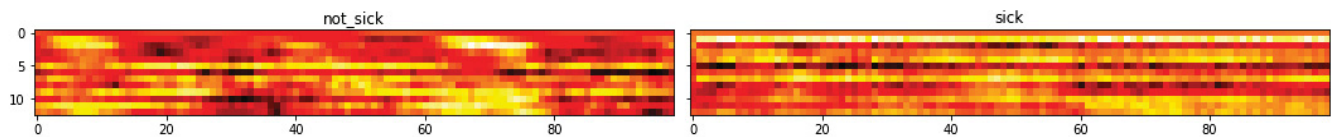

Fig. 5. Mel Frequency Cepstrum Coefficients

not rhythmic and stable, which confirms his infection with COVID-19.

It should be noted that an audio signal is a complex signal made up of several single-frequency sound waves which move together like a medium interference. When audio is recorded, we only catch the resulting amplitudes of these multiple waves. The Discrete Fourier Transform (DFT) is a mathematical model that decomposes a discrete time signal into its constituent frequencies. The DFT not only provides the frequencies defined in the signal, but it also gives the amplitude of each frequency present in the signal, as defined in Eq. 1 in which the Hamming window is used to remove any possible spectral leakage.

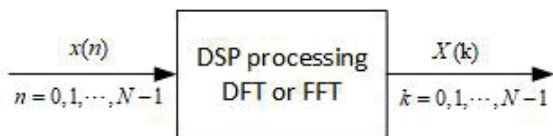

Fig. 6. Application of DFT

$$X(k) = \sum_{i=0}^{N-1} x(i) \cdot e^{-j2\pi \frac{i \cdot k}{N}} \quad (1)$$

where  $X(k)$  denotes the DFT coefficient in frequency domain. The index  $i$  is the time index representing the sample

number of the input digital sequence  $x(i)$ , whereas  $k$  is the frequency index indicating each calculated DFT coefficient, and can be further mapped to the corresponding signal frequency. Generally, the DFT is used to characterize a discrete time signal by its frequency spectrum and in particular to highlight the importance of the fundamental harmonic as well as the more or less rapid decrease in the amplitude of higher-order harmonics, as denoted in Fig. 6. In our case, it can also be used to determine the number of harmonics needed to characterize the sick and not\_sick cough and breathing signals properties. However, in the case of sick patient (Fig. 3 right side) the signal spectrum consists of several harmonics unlike the not\_sick case (Fig. 3 left side), which provides a streamlined characterization of the COVID-19 infection.

In addition, the power spectrum analysis as seen in Fig. 3, which is denoted as the technique used to calculate the frequency spectrum by applying the DFT to variations in a certain signal. It indicates the relative magnitudes of the frequency components that combine to make up the signal. However, the power spectrum has a wider range of applicability and can be defined for some signals that do not have a meaningful Fourier transform. Since the power spectrum does not contain phase information, it is applied in situations where the phase is not considered useful or to data that contain a lot of noise, since phase information is easily corrupted by noise. Eq. 2 denotes the one-sided power spectrum density. Where

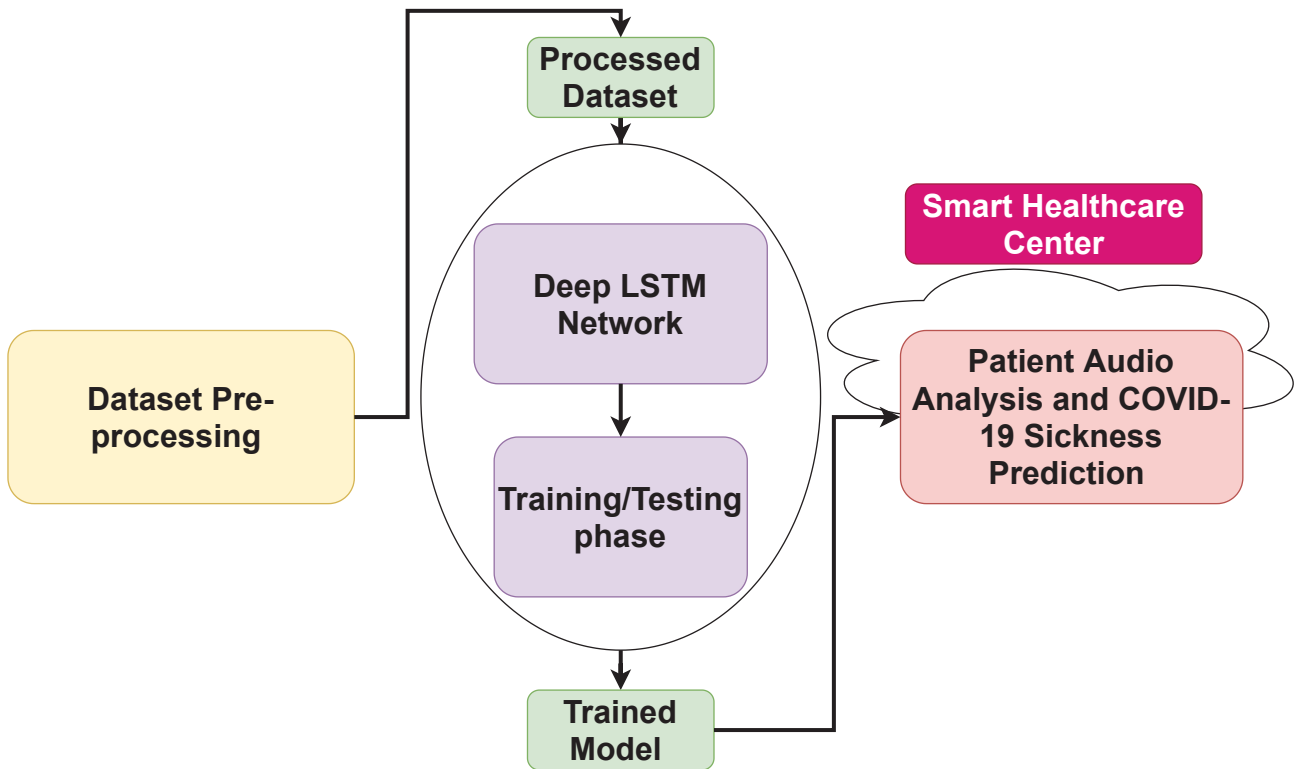

Fig. 7. The Proposed Deep Learning-based Framework

$X(k)$  represents the  $k^{th}$  DFT result of the defined input signal  $x$  and  $N$  is the data length typically about 256 or 512 (NFFT=256 or 512).

$$P_k = \begin{cases} \frac{1}{N^2} \cdot |X(0)|^2 & k = 0 \\ \frac{2}{N^2} \cdot |X(k)|^2 & k = 1, 2, \dots, N/2 \end{cases} \quad (2)$$

After that, the Filter Bank is applied to each audio signal in the data set. Generally, Filter-Banks are commonly employed for adaptive subband filtering, for example, to perform acoustic echo-cancellation in hands-free communication devices or multi-channel dynamic-range compression in digital hearing aids. However, it divides the input signal into a set of analysis signals, each of which corresponds to a different region in the spectrum. Fig. 4 shows the spectrum of a Filter Bank Coefficient, which is the result of the FFT algorithm applied on the speech data and then used for the convolution with a triangular window function to reduce Gibbs effect.

Finally, Mel-frequency cepstrum coefficients (MFCCs) is considered as features in audio analysis [28]. MFCC is useful to differentiate dry cough from wet coughs [29]. With the advent of Deep Learning in speech systems, one might question if MFCCs are still the right choice given that deep neural networks are less susceptible to highly correlated input and therefore the Discrete Cosine Transform (DCT) is no longer a necessary step. It is beneficial to note that DCT is a linear transformation, and therefore undesirable as it discards some

information in speech signals which are highly non-linear. Fig. 5 depicts the MFCC features for an audio signal. It is remarkable that the not\_sick MFCCs figure is different from the sick figure in terms of the number of resulting coefficients. The classical MFCC extraction technique is used considering higher resolution MFCCs, while mel-scaled filters are calculated as follows (3).

$$Mel(f) = 2595 \times \log\left(1 + \frac{f}{700}\right) \quad (3)$$

### III. PROPOSED DEEP LSTM NEURAL NETWORK FOR COVID-19 COUGH AND BREATH RECOGNITION

Audio Classification has become a significant task for machines to perceive the surrounding auditory scene. However, extracting effective representations that capture the underlying characteristics of the audio events is still challenging. Meanwhile, with the rapid COVID-19 spread, the virtual early diagnosis (Connected to the healthcare center via wearable sensors) can help the world in surrounding viruses and gain more time to produce efficient vaccines. In this regard, the combination of advanced technologies (connected body sensors, smart phone, smart watch, smart home) and advanced techniques, as well as Artificial Intelligent (AI) (Machine/ Deep Learning), can well contribute to this pandemic. In this context, we propose a supervised deep learning framework based on Deep LSTM Network to learn a vector representation of a patient's audio



sequence [30]. The primary aim of this framework is to detect COVID-19 infection from audio pattern analysis. Fig. 7 shows the proposed deep learning framework-based audio COVID-19 detection.

In the first step, data gathered from the Internet of Things and wearable sensors, which are heterogeneous, bulky, and full of typos, cannot be applied as inputs for advanced healthcare machine learning applications. To beat this trouble and provide data trends, collected data must go through a cleaning process. This process includes data transformation, metadata enrichment exploitation, exploration, for example, entering missing values, removing unnecessary or invalid data that is not required to obtain data trends, then data validation. This process is well described in section II. After that, in the offline phase, the proposed deep Long Short-Term Memory (LSTM) network will be trained on the processed dataset. Hence, the trained model will be used in an online phase (real healthcare application) to predict patient COVID-19 infection based on audio data.

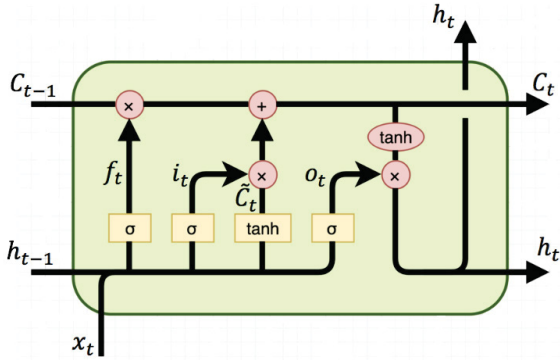

Fig. 8. Long Short-Term Memory cell

LSTM is used especially in speech recognition. It is a special kind of Recurrent Neural Networks (RNN) that could learn long-term dependencies. It was introduced by Sepp Hochreiter and Jorgen Schmidhuber in 1997 [31]. It was developed to avoid exploding and vanishing gradient problems that can occur when training RNNs. An LSTM cell is made up of input gate, forget gate, and output gate, as shown in Fig. 8. The mathematical equations for the gate are to protect information by stopping or allowing its flow.

The input gate ( $i_t$ ) defines the required information from the previous layer is stored in the cell. The forgetting gate ( $f_t$ ) looks like a weird listing at first but sometimes it's a good idea to forget about it. The output gate ( $o_t$ ) takes the job on the other end and defines how much the next layer knows the state of this cell. The LSTM cell gates are modeled in the following equations.

$$\begin{aligned}
 i_t &= \sigma(w_i \cdot [h_{t-1}, x_t] + b_i) \\
 o_t &= \sigma(w_o \cdot [h_{t-1}, x_t] + b_o) \\
 f_t &= \sigma(w_f \cdot [h_{t-1}, x_t] + b_f) \\
 \tilde{C}_t &= \tanh(w_c \cdot [h_{t-1}, x_t] + b_c) \\
 C_t &= f_t * C_{t-1} + i_t * \tilde{C}_t \\
 h_t &= o_t * \tanh(C_t)
 \end{aligned} \tag{4}$$

where  $x_t$  is the input vector and  $C_t$  is the state cell of the LSTM unit.  $\sigma$  and  $\tanh$  are the activation functions and  $h_t$  is the output vector (Hidden state).

#### IV. SIMULATION RESULTS

This section introduces the achieved results of the proposed deep learning framework-based patient COVID-19 infection from audio data. However, the Python language was used as a software kit with machine learning libraries, such as Tensorflow and Keras. The used platform implements windows 10 OS with Intel@core TM i7-3770 @3.4 GHz CPU, 16 GB RAM, and an NVIDIA GeForce RTX 2070 GPU. Regarding the customized hyperparameters to the proposed deep learning scheme are the batch size (32), the learning rate (0.0001), the epochs number (400), the optimizer (Adam), and the loss function (binary\_crossentropy).

To provide an in-depth performance evaluation of the proposed framework, Table. I shows the evaluation metrics formulas in terms of precision (P), F1\_score, recall (R), and the accuracy which are the suitable metrics used to evaluate the scheme. Where, TP, TN, FP, and FN denoted, respectively, as True Positives, True Negatives, the number of False Positives, and the number of False Negatives.

TABLE I. PERFORMANCE METRICS

Metrics	Formula	Metrics	Formula
Precision, P	$TP/(TP + FP)$	Recall, R	$TP/(TP + FN)$
F1_score	$2 \times (P \times R)/(P + R)$	Accuracy	$TP + TN / (TP + FP + FN + TN)$

Table. II resumes the LSTM model summary proposed in this work. In this context, the architecture of the LSTM model is composed of three LSTM cells and each of them has 64 units. Then, the LSTM model is followed by a fully connected layer (Output layer). The dropout layer is used to prevent the overfitting. Finally, the sigmoid activation function is used to activate the output layer.

For the training process, Fig. 9 presents the overall accuracy and loss results. As depicted in Fig. 9, our proposed Deep LSTM framework achieved up to 80% of accuracy at the 400 epochs. While the loss value is around 20% at the last epoch. These results prove the effectiveness of our framework, especially when the validation accuracy and loss curves follow the accuracy and loss curves, which means that no overfitting problem has occurred in this framework while this problem is often found in many LSTM network-based schemes.

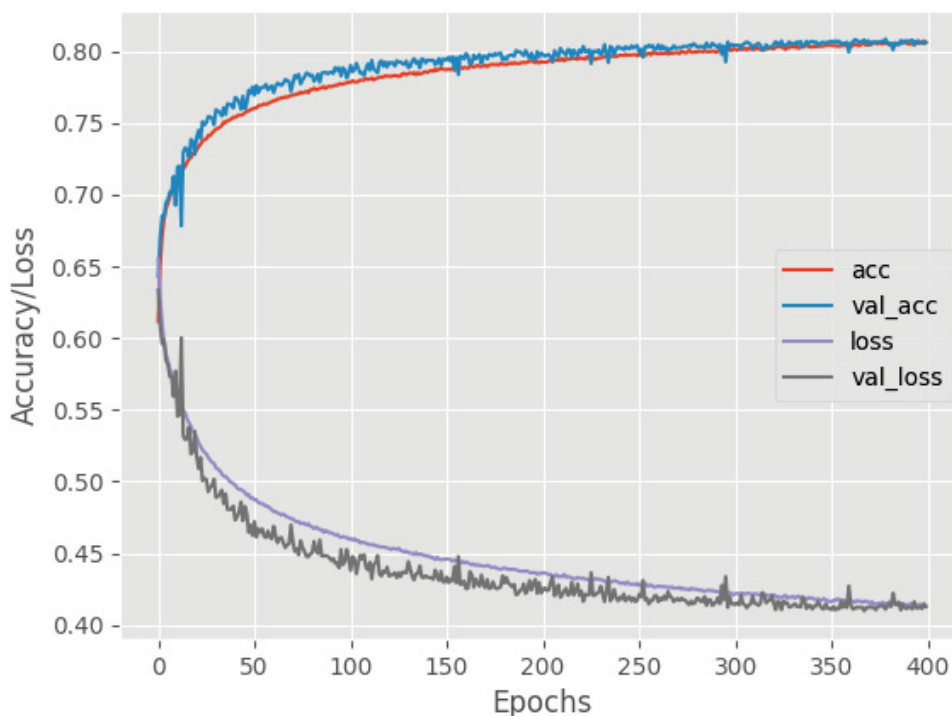

Fig. 9. Training Analysis on the sickness and non-sickness Audio Signal

TABLE II. LSTM MODEL SUMMARY

Layer (Type)	Output Shape	Parameters
lstm (LSTM)	(None, 3, 64)	19968
dropout (Dropout)	(None, 3, 64)	0
lstm_1 (LSTM)	(None, 3, 64)	33024
dropout_1 (Dropout)	(None, 3, 64)	0
lstm_2 (LSTM)	(None, 64)	33024
dropout_2 (Dropout)	(None, 64)	0
dense (Dense)	(None, 2)	130

For the testing process, the overall precision of the normal case (not COVID-19) is about 79.5% and 79% for the confirmed case (COVID-19). Hence, the mean recall of both classes is about 78.75%, while the mean F1\_score is 79%. Table. III summarizes these metrics values. On the other hand, and as denoted in this table, our proposed model outperforms the other in [32] in terms of overall accuracy, in which the proposed scheme reaches over than 80% compared to the other, when the LSTM model used without any other combinations (with other techniques). As a limitation, when compared to the one proposed in [32], especially to the LSTM+SFS, here

the proposed framework needs to be improved.

## V. CONCLUSION

COVID-19 is a large family of viruses that cause illnesses ranging from colds to more serious diseases that can lead to death. Due to advanced AI technology, early detection of this virus will help rapid recovery. This paper proposed a deep LSTM technique to diagnose and detect COVID-19 infection from cough, breath, and sneeze signals. Performance results prove that the proposed scheme yielded the highest accuracy, over more than 80%, compared to the others in which the LSTM is used as a single model without any combination.

## ACKNOWLEDGMENT

This work was funded by OMANTEL under grant number “EG/SQU-OT/18/01”. The authors, therefore, acknowledge OMANTEL and Sultan Qaboos University for their financial support.

## REFERENCES

- [1] D. S. Hui, E. I. Azhar, T. A. Madani, F. Ntoumi, R. Kock, O. Dar, G. Ippolito, T. D. Mchugh, Z. A. Memish, C. Drosten *et al.*, “The continuing 2019-ncov epidemic threat of novel coronaviruses to global health—the latest 2019 novel coronavirus outbreak in wuhan, china,” *International journal of infectious diseases*, vol. 91, pp. 264–266, 2020.
- [2] M. Shorfuzzaman, M. S. Hossain, and M. F. Alhamid, “Towards the sustainable development of smart cities through mass video surveillance: A response to the covid-19 pandemic,” *Sustainable cities and society*, vol. 64, p. 102582, 2021.
- [3] A. Carfi, R. Bernabei, F. Landi *et al.*, “Persistent symptoms in patients after acute covid-19,” *Jama*, vol. 324, no. 6, pp. 603–605, 2020.

TABLE III. PERFORMANCE COMPARISON OF THE PROPOSED LSTM MODEL

Approaches	Models	Class	Precision (%)	Recall (%)	F1_score (%)	Accuracy (%)
[32]	CNN	Sick+Not-sick	—	85	—	73.02
	LSTM	Sick+Not-sick	—	75	—	73.78
[32]	ResNet50	Sick+Not-sick	—	93	—	74.58
	LSTM+SFS	Sick+Not-sick	—	91	—	92.91
Proposed	LSTM	Sick	79	79.5	79	80.26
		Not-sick	79.5	78	79	80.26

- [4] WHO, "Covid-19 global situation," <https://covid19.who.int/>, 2021, [Online; accessed 18-02-2021].
- [5] L. Khriji, M. Fradi, M. Machhout, and A. Hossen, "Deep learning-based approach for atrial fibrillation detection," *Springer book chapter in The Impact of Digital Technologies on Public Health in Developed and Developing Countries*, no. LNCS 12157, pp. 100–113, 2020.
- [6] M. Fradi, L. Khriji, M. Machhout, and A. Hossen, "Automatic heart disease class detection using convolutional neural network architecture based various optimizers-networks," *IET Smart Cities*, vol. 3, no. 1, pp. 3–15, 2021.
- [7] S. Walvekar, D. Shinde *et al.*, "Detection of covid-19 from ct images using resnet50," *Detection of COVID-19 from CT images using resnet50 (May 30, 2020)*, 2020.
- [8] H. Sotoudeh, M. Tabatabaei, B. Tasorian, K. Tavakol, E. Sotoudeh, and A. L. Moini, "Artificial intelligence empowers radiologists to differentiate pneumonia induced by covid-19 versus influenza viruses," *Acta Informatica Medica*, vol. 28, no. 3, p. 190, 2020.
- [9] M. Yildirim and A. Cinar, "A deep learning based hybrid approach for covid-19 disease detections," *Traitement du Signal*, vol. 37, no. 3, pp. 461–468, 2020.
- [10] A. K. Jaiswal, P. Tiwari, V. K. Rathi, J. Qian, H. M. Pandey, and V. H. C. Albuquerque, "Covidpen: A novel covid-19 detection model using chest x-rays and ct scans," *medRxiv*, 2020.
- [11] M. Loey, F. Smarandache, and N. E. M. Khalifa, "Within the lack of chest covid-19 x-ray dataset: a novel detection model based on gan and deep transfer learning," *Symmetry*, vol. 12, no. 4, p. 651, 2020.
- [12] I. D. Apostolopoulos and T. A. Mpesiana, "Covid-19: automatic detection from x-ray images utilizing transfer learning with convolutional neural networks," *Physical and Engineering Sciences in Medicine*, vol. 43, no. 2, pp. 635–640, 2020.
- [13] X. Xu, X. Jiang, C. Ma, P. Du, X. Li, S. Lv, L. Yu, Q. Ni, Y. Chen, J. Su *et al.*, "A deep learning system to screen novel coronavirus disease 2019 pneumonia," *Engineering*, vol. 6, no. 10, pp. 1122–1129, 2020.
- [14] S. Wang, B. Kang, J. Ma, X. Zeng, M. Xiao, J. Guo, M. Cai, J. Yang, Y. Li, X. Meng *et al.*, "A deep learning algorithm using ct images to screen for corona virus disease (covid-19)," *MedRxiv*, 2020.
- [15] J. Chen, L. Wu, J. Zhang, L. Zhang, D. Gong, Y. Zhao, Q. Chen, S. Huang, M. Yang, X. Yang *et al.*, "Deep learning-based model for detecting 2019 novel coronavirus pneumonia on high-resolution computed tomography," *Scientific reports*, vol. 10, no. 1, pp. 1–11, 2020.
- [16] A. B. Chang, G. Redding, and M. Everard, "Chronic wet cough: protracted bronchitis, chronic suppurative lung disease and bronchiectasis," *Pediatric pulmonology*, vol. 43, no. 6, pp. 519–531, 2008.
- [17] J. Korpáš, J. Sadloňová, and M. Vrabec, "Analysis of the cough sound:
- [18] M. Al-Khassaweneh and R. Bani Abdelrahman, "A signal processing approach for the diagnosis of asthma from cough sounds," *Journal of medical engineering & technology*, vol. 37, no. 3, pp. 165–171, 2013.
- [19] G. Botha, G. Theron, R. Warren, M. Klopper, K. Dheda, P. Van Helden, and T. Niesler, "Detection of tuberculosis by automatic cough sound analysis," *Physiological measurement*, vol. 39, no. 4, p. 045005, 2018.
- [20] R. V. Sharan, U. R. Abeyratne, V. R. Swarnkar, and P. Porter, "Automatic croup diagnosis using cough sound recognition," *IEEE Transactions on Biomedical Engineering*, vol. 66, no. 2, pp. 485–495, 2018.
- [21] G. Deshpande and B. Schuller, "An overview on audio, signal, speech, & language processing for covid-19," *arXiv preprint arXiv:2005.08579*, 2020.
- [22] C. Brown, J. Chauhan, A. Grammenos, J. Han, A. Hasthanasombat, D. Spathis, T. Xia, P. Cicuta, and C. Mascolo, "Exploring automatic diagnosis of covid-19 from crowdsourced respiratory sound data," in *Proceedings of the 26th ACM SIGKDD International Conference on Knowledge Discovery & Data Mining*, 2020, pp. 3474–3484.
- [23] A. Pal and M. Sankarasubbu, "Pay attention to the cough: Early diagnosis of covid-19 using interpretable symptoms embeddings with cough sound signal processing," *arXiv preprint arXiv:2010.02417*, 2020.
- [24] P. Bagad, A. Dalmia, J. Doshi, A. Nagrani, P. Bhamare, A. Mahale, S. Rane, N. Agarwal, and R. Panicker, "Cough against covid: Evidence of covid-19 signature in cough sounds," *arXiv preprint arXiv:2009.08790*, 2020.
- [25] J. Laguarda, F. Hueto, and B. Subirana, "Covid-19 artificial intelligence diagnosis using only cough recordings," *IEEE Open Journal of Engineering in Medicine and Biology*, vol. 1, pp. 275–281, 2020.
- [26] D. P. Shyamal Patel, Adan Rivas, "Dataset of sounds of symptoms associated with respiratory sickness," <https://osf.io/tmkud/>, 2021, [Online; accessed 18-02-2021].
- [27] W. Han, C.-F. Chan, C.-S. Choy, and K.-P. Pun, "An efficient mfcc extraction method in speech recognition," in *2006 IEEE international symposium on circuits and systems*. IEEE, 2006, pp. 4–pp.
- [28] H. Chatzarrin, A. Arcelus, R. Goubran, and F. Knoefel, "Feature extraction for the differentiation of dry and wet cough sounds," in *2011 IEEE international symposium on medical measurements and applications*. IEEE, 2011, pp. 162–166.
- [29] S. Messaoud, A. Bradai, S. H. R. Bukhari, P. T. A. Quang, O. B. Ahmed, and M. Atri, "A survey on machine learning in internet of things: Algorithms, strategies, and applications," *Internet of Things*, vol. 12, p. 100314, 2020.
- [30] S. Hochreiter and J. Schmidhuber, "Long short-term memory," *Neural computation*, vol. 9, no. 8, pp. 1735–1780, 1997.
- [31] M. Pahar, M. Klopper, R. Warren, and T. Niesler, "Covid-19 cough classification using machine learning and global smartphone recordings," *arXiv preprint arXiv:2012.01926*, 2020.