

RFID Tattoo for COVID-19 Temperature Measuring

Tagleorge Marques Silveira
Universidade de Aveiro - UA
Instituto de Telecomunicações - IT
Aveiro, Portugal
tagleorge@ua.pt

Pedro Pinho
Instituto Sup. de Eng. de Lisboa -ISEL
Instituto de Telecomunicações - IT
Aveiro, Portugal
ptpinho@av.it.pt

Nuno Borges Carvalho
Universidade de Aveiro - UA
Instituto de Telecomunicações - IT
Aveiro, Portugal
nbcvalho@ua.pt

Abstract — In order to assist in the screening and monitoring of possible infected by COVID-19, whose fever is one of the initial symptoms, a RFID tattoo tag for human monitoring was developed. The prototype of the tattoo tag presented proved to be effective in measuring human body temperature from 36° to 40° C, thus being a viable option for large-scale screening and analysis, and for being made with aluminum foil and school adhesive tape. That when using these materials, it presents itself as a disposable device, of low cost, durable, and operable in the RFID UHF frequency range.

Keywords — RFID tattoo, COVID-19, temperature.

I. INTRODUCTION

At the end of 2019 a new virus called the new corona virus - SARS-CoV-2 or COVID-19, with its rapid multiplication and transmission, originally detected in hospitals in Wuhan - China, which in just a few months became the propellant of a pandemic on Earth planet. The world population, without defenses to this invisible enemy, was forced to remain in quarantine for months until effective control and sanitation forms against this new global threat were obtained and developed.

According to studies [1] and [2], it was noticeable that one of the initial and most common symptoms, is fever, this was measured in most of those infected. According to official data from the World Health Organization - WHO [3] and the National Health Service - SNS in Portugal [4], the human body temperature must be between (36° and 37° C) or (96.8° and 98.6° F), and above 37.7° C or 100° F it is considered a feverish state.

As soon as it is observed that gauging the temperature is an effective way to screen infected people and based on the possibility of using the Radio-Frequency Identification - RFID Chipless technology, using the principle of an RFID tag-tattoo incorporated into human skin and based on the works [5 - 7], an intense investigation was carried out in order to obtain a favorable and adaptable design to the epithelial tissue and that operated in Ultra High Frequency - UHF in the frequency range of 800 to 1000 MHz

After the analysis of simulations, a low-cost prototype was manufactured using sheets of aluminum foil and school adhesive tape, the results of which were satisfactory and are presented in this paper. Section II presents the challenges of obtaining design and manufacturing, then Section III presents measurement data in its different stages, and finally, the final considerations are made.

II. DESIGN OF A CHIPLESS TAG-TATTOO

Aware that the measurement of fever is a monitoring factor for possible infected by COVID-19, and with the use of RFID concepts, a tag was developed capable of varying its resonance with the change in human temperature, using the epithelial tissue as dielectric human. The use of the CST Studio software was successfully applied to obtain a design adaptable to human hair and operational in the UHF - 800 to 1000 MHz band, as shown in Fig. 1.

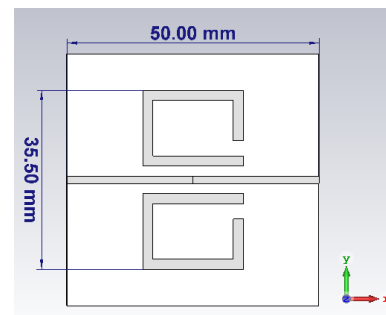

Fig. 1. RFID Chipless tag design.

After successive simulations, the design was obtained in the dimensions expressed in Fig. 1 and the S_{11} simulated results are presented within the frequency range UHF - 800 to 1000 MHz as shown in Fig. 2.

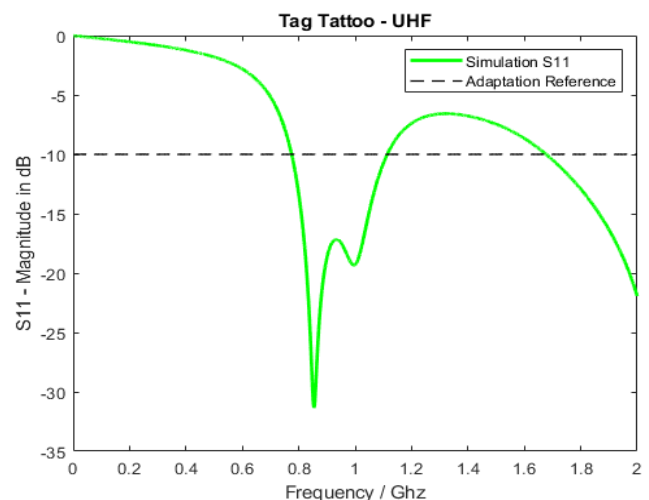

Fig. 2. Simulated results of the RFID tag.

With the use of a CNC Machine, the tag-tattoo was manufactured in aluminum foil with the elaborate design and using school adhesive tape, a low-cost tag that was easy to manufacture in scale was obtained, according to the Fig. 3.

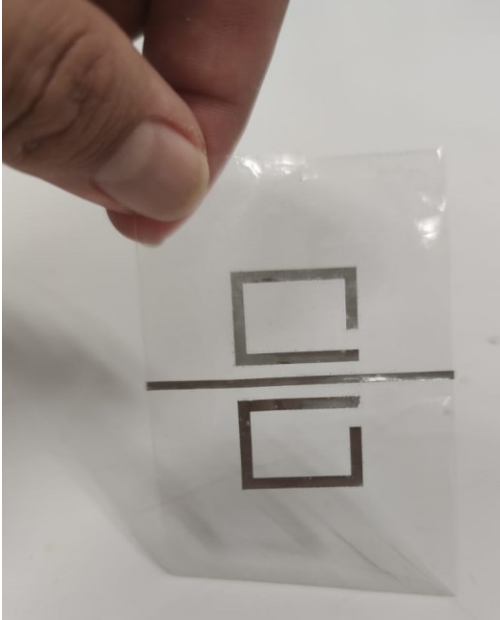

Fig. 3. Manufactured RFID tattoo.

III. MEASURED AND SIMULATED RESULTS

In a valid manufacturing way, the tattoo tag was easily attached to a human arm, as shown in Fig. 4.



Fig. 4. RFID tattoo attached to a human arm.

With the fixing application to the arm made, a measurement setup was made up consisting of two UHF 800 MHz - 1.1 GHz RFID reader antennas connected to a Keysight N9918A Portable VNA, as shown in Fig. 5.

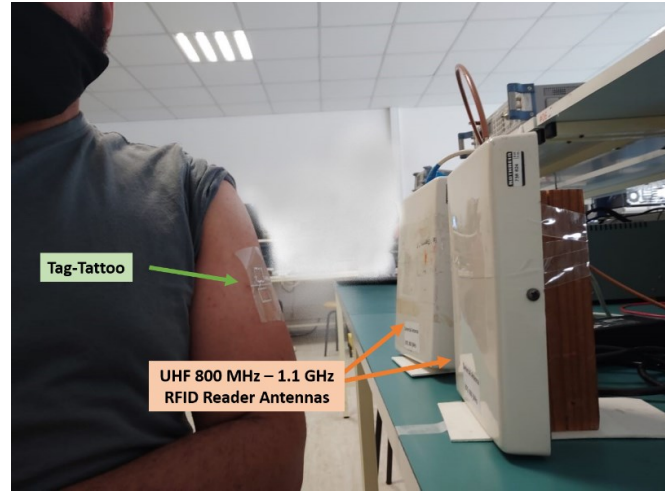

Fig. 5. Measurement setup on a human arm.

The results of the measurement setup are presented in Fig. 5 were satisfactory, as the tag-tattoo was detected when measuring the S_{21} between the RFID reader antennas. This detection is shown in Fig. 6, which compares the signal before and after the presence of the tag-tattoo on the human arm in front of the reader antennas.

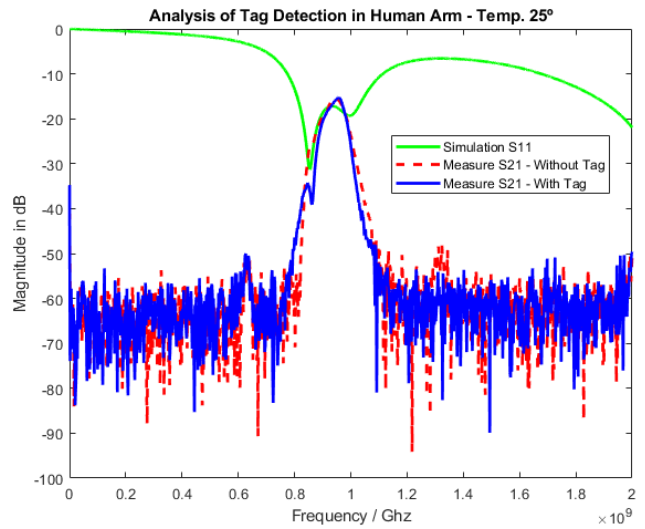

Fig. 6. Results of the setup measurement in Fig. 5.

As soon as the operation of the tattoo tag was verified, a second measurement setup was created to enable the variation of the tag's temperature. Thus, using a Climatic Chamber Angelantoni Industrie Model CH340, and a chicken breast whose dielectric characteristics are similar to that of human skin, the measurement was carried out at different temperatures, Fig. 7 e Fig. 8.



Fig. 7. Internal view: Setup of Temperature Variation in a Climatic Chamber using a chicken breast.

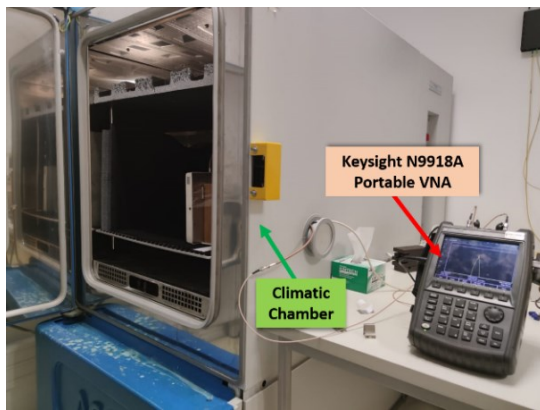

Fig. 8. External View: Setup of Temperature Variation in a Climatic Chamber using a chicken breast.

The temperature variation procedure performed in the setup shown in Fig. 7 and Fig. 8, had its temperature varied from 36° C to 40° C, with measurements performed gradually from 1° to 1° C. Graphically it is possible to visualize a shift in the resonance frequency, between the data obtained for the temperatures of 36° and 40°, as shown in Fig. 9.

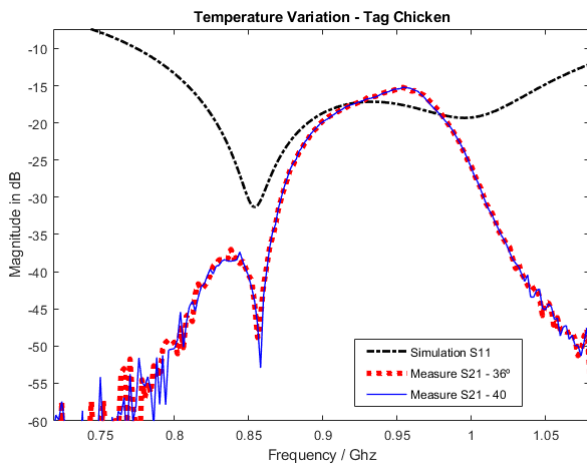

Fig. 9. Temperature variation – Tattoo tag chicken 36° and 40° C.

In more detail, in Fig. 10 the temperature variation from 1° to 1° is gradually presented at the frequency of 860 MHz.

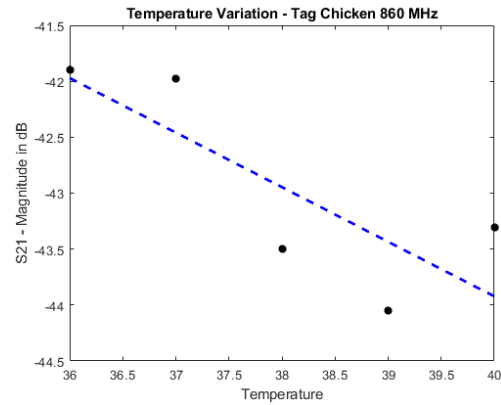

Fig. 10. Tattoo tag chicken in 860 MHz - 36° to 40° C.

IV. CONCLUSION

After intense investigation, it was possible to build a tattoo tag to measure the temperature from a distance using RFID technology. The use of aluminum paper was the key point for the success of this prototype, as it is highly conductive and very malleable, and with the use of a school adhesive tape, it was possible to obtain a great durability of use for more than 3 days, making thus a low-cost, compact and durable model.

ACKNOWLEDGMENT

The authors acknowledge the help of Instituto de Telecomunicações – IT Aveiro, and this work is supported by the European Regional Development Fund (FEDER), through the Regional Operational Program of Lisbon (POR LISBOA 2020) and the Competitiveness and Internationalization Operational Program (COMPETE 2020) of the Portugal 2020 framework [Project CoViS with Nr. 070090 (POCI-01-02B7-FEDER-070090)].

REFERENCES

- [1] Chacón-Aguilar, Rocío et al. "COVID-19: Fever syndrome and neurological symptoms in a neonate." *Anales de pediatria*, vol. 92,6 373–374. 27 Apr. 2020, doi:10.1016/j.anpede.2020.04.001.
- [2] Baig, Abdul Mannan. "Neurological manifestations in COVID-19 caused by SARS-CoV-2." *CNS neuroscience & therapeutics* vol. 26,5 (2020): 499-501. doi:10.1111/cns.13372.
- [3] World Health Organization – WHO, Accessed on: June 3, 2018. [Online]. Available: <https://www.who.int/data/gho/indicator-metadata-registry/imr-details/180>.
- [4] Serviço Nacional de Saúde – SNS - Portugal, Accessed on: June 3, 2018. [Online]. Available: <https://www.sns24.gov.pt/tema/sintomas/febre/#sec-3>.
- [5] M. A. Ziai and J. C. Batchelor, "Temporary On-Skin Passive UHF RFID Transfer Tag," in *IEEE Transactions on Antennas and Propagation*, vol. 59, no. 10, pp. 3565-3571, Oct. 2011. doi: 10.1109/TAP.2011.2163789.
- [6] D. O. Oyeka, M. A. Ziai, J. C. Batchelor, E. A. Parker, V. Sanchez-Romaguera and S. G. Yeates, "Developing inkjet printing to enable low cost UHF RFID transfer tattoo tags," 2013 *IEEE Antennas and Propagation Society International Symposium (APSURSI)*, Orlando, FL, 2013, pp. 1726-1727. doi: 10.1109/APS.2013.6711522.
- [7] D. H. Kim, N. Lu, R. Ma, Y.S. Kim, R.H. Kim, S. W, S. M. Won, H. Tao, A. Islam, K.J. Yu, T. Kim, R. Chowdhury, M. Ying, L. Xu, J. Wu, M. Li, H.J. Chung, F. G. Omenetto, Y. Huang, Todd P. Coleman, John. A. Rogers, "Epidermal Electronics", *Science*, Aug 12, 2011, Vol. 333, Issue 6044, pp. 838-843, DOI: 10.1126/science.1206157.