

# Automatic Health Machine for COVID-19 and Other Emergencies

Divya Ganesh, Gayathri Seshadri, Sumathi Sokkanarayanan, Panjavarnam Bose,  
Sharanya Rajan, Mithileysh Sathiyarayanan  
Sri Sairam Engineering College, Chennai, India  
University Hospital Southampton NHS Trust, UK  
Research & Innovation, MIT Square, India & UK  
Email: Mithileysh@mitsquare.com

**Abstract**—The novel Corona Virus (COVID-19) is a pandemic of unimaginable proportion and magnitude that is posing a great challenge worldwide to the medical industry in the 21st century. It has completely changed the texture of life to a greater extent. The increasing number of victims succumbing to the disease has created an indelible fear in the minds of the people who are afraid to access even the basic healthcare facilities. This paper deals with the Automatic Health Machine (AHM) which uses IoT and Artificial Intelligence technologies to help users access medical facilities during a pandemic and medical emergency mostly in rural and urban areas. The AHM provides complete virtual health checkup, connects with the doctor or specialist online and books appointments for the swab test or ambulance in case of emergency based on the patient's condition, dispenses the swab test or emergency medicines and electronic prescription to patients for later reference. The services of the AHM are accessible to all individuals using "Smart Health Card". According to the Sustainable Development Goals (SDG-3) proposed by the United Nations, the AHM ensures the well-being of all ages in society and increases the survival rate during unprecedented times like a pandemic/epidemic. We collaborated with industries and hospitals to understand healthcare/patients' requirements considering pandemic and post-pandemic. We conducted virtual workshops with the COVID-recovered patients and frontline nurses and doctors. As an overall outcome, the healthcare professionals feel the system can be adopted in an area where medical facility is not available immediately. Thus, our work has led to a patent being published in India and USA.

**Index Terms**—Healthcare; automated dispensing machine; automated dispensing device; automated dispensing cabinet; autospense; vending machine; telemedicine; telehealth; internet of things; coronavirus; COVID.

## I. INTRODUCTION

The pandemic COVID-19 is a great threat to mankind globally irrespective of whether it is a developing or developed country. In developing countries like India, which includes 65.53% of the rural population, access to primary health care is very minimal. Due to the lack of basic healthcare facilities, mortality rates and diseases are on the rise. So, the implementation of AHM system in primary healthcare centres or hospitals in rural areas can help people access basic and advanced healthcare facilities, create awareness of various diseases, control the spread of pandemics and considerably bring down the mortality rates.

This system can be a boon to developing countries like India which focuses on uniform healthcare facilities to its citizens. India's Honourable Prime Minister Narendra Modi has recently launched a universal healthcare policy called National Digital Health Mission (NDHM) which envisages a complete digital health ecosystem based on personal health IDs for every Indian citizen. The health documents will be provided in 3 layers: Electronic Medical Record (EMR), Electronic Health Record (EHR), Personal Health Record (PHR) with the health ID. This paper is an attempt in the same direction to support the government initiative in introducing digitalization and quality healthcare throughout India.

## II. RELATED WORK

Point of care patient education Kiosk [1], installed in waiting areas of California and Veterans Affairs clinics has access to selected websites which provide information related to various diseases and stores the health information of the patients. The results from the questionnaire show that nearly 82% of users find that information availed would help them follow doctor's advice and nearly 71% of users said that the kiosk helped them to recognize their state of health .

The Health Monitoring Kiosk [2] provides facility to keep track of vital medical parameters like Blood Pressure (BP), Body Mass Index (BMI), Electronic cardiograph (EKG), body Fat, pulse Rate, weight and uploads the results on the cloud. Reports based on the health checkup are displayed in the Kiosk and provides an alternative to mail the report to the patient for future reference.

COVSACK (COVid SAMple Collection Kiosk) [3], focuses on collecting samples from patients by placing them inside the kiosk which protects healthcare providers and prevents the spread of infection in case of any sneezing or coughing at the time of sample collection. The automatic disinfection followed by water cleaning procedure ensures best sanitation practices and eliminates the risk of exposure of the healthcare workers to the infection while collecting samples from infected patients.

Autospense [4] is a standalone machine that manages medicines and distributes them securely and evenly. This automated dispenser can be used in pharmacies where it can relieve the owner and employees from repetitive tasks. It keeps track of the inventory, provides security with the help of

cameras placed in inventory, manages inventory and dispenses medicines.

Health Kiosk [5], [6] is an interactive stand-alone device offers healthcare information about the patient, reduces waiting time in clinics and provides quick medical access to patients. Its services are greatly appreciated in emergency conditions as it gathers patients' information and payment options before starting the treatment in any place.

### III. AUTOMATIC HEALTH MACHINE

Automatic Health Machine (AHM) uses technologies like IoT and Artificial Intelligence to provide quick and quality healthcare services to users [7]. It provides facilities like sanitation, patient screening for COVID symptoms, books appointments for swab test at nearby hospitals, calls or books ambulance services, provides SMS services to patients' mobile regarding health advice and results of swab test. It also provides additional facility for family members to track the health of the COVID patient during hospitalization, dispenses medicines and helps bystanders to book ambulance from nearby hospitals or health centers and assists the victims of accidents during emergencies. The main advantage of the AHM in rural or urban areas is the power-efficient design using IR sensor. So AHM can provide instant services 24x7. The AHM serves its purpose if installed in highways, COVID affected areas and accident prevention zones. Since the residents in the quarantined areas are not allowed to leave their homes, and the public has an indelible fear for visiting hospitals or healthcare centres to protect themselves from the pandemic, installing AHM near their area can help every resident to access the healthcare facility in emergency situations. Fig. 1 shows the COVID Screening workflow in AHM.

#### A. For COVID Screening

The IR sensor detects the movement, and the system recovers from the sleep state, ensuring the energy-efficient design of the AHM. When a person is detected, the UV-C lights are triggered to sanitize the persons hand before the use of the AHM. As the sanitizers are unreliable and require continuous refilling, the UV-C lights can provide perfect sanitization to the users which are comparatively more reliable. The patient inserts the Smart Health card and accesses the AHM facility using the dedicated PIN number set. The Chatbot initialized asks for the symptoms from the patient, and the IR temperature sensors are triggered to record the temperature contactless. The facilities will be accessed based on the following conditions : 1) If the Temperature is  $\geq 100$ , AHM initiates the Online video call with the physician. a) In case of serious illness, AHM books for the swab test in the nearby hospital and calls the ambulance service if required for transport. b) The test results reach the patient via SMS services or a dedicated link. This greatly reduces the patient's anxiety about the results. c) If Tested Positive: The patient's family members can track the health of the COVID patient during hospitalization using the dedicated link as otherwise the patients' condition will be known only if he informs the family members. This

prevents fear and worry among the family members. 2) If the temperature is normal or the test is negative, the doctors prescribe medicines which are dispensed using the AHM or through online pharmacies in case they are out of stock

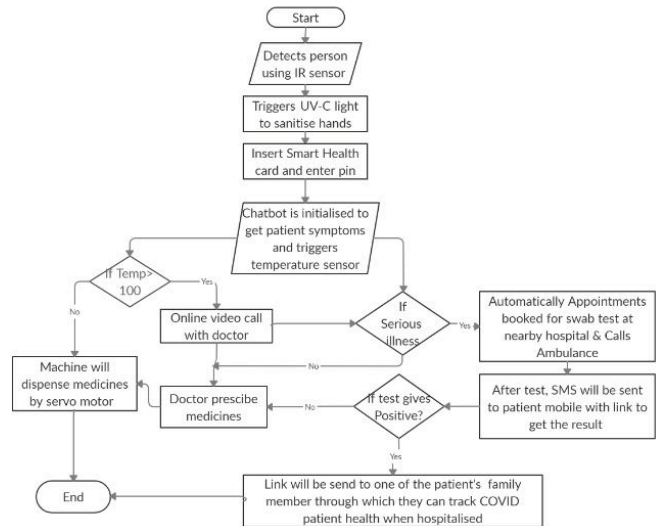

Fig. 1. COVID Screening Workflow in the Automatic Health Machine.

### IV. IMPLEMENTATION

The circuit diagram and the Block diagram of the AHM are shown in the Fig.2 and 3 respectively. The AHMs are provided with a high-grade accuracy sensor to get inputs from the patients' inputs regarding symptoms and general information : the features being ,Microcontroller (Raspberry pi) and Microprocessor (ATMEGA 328- Arduino UNO) process the commands, interactive Touch screen display and Web camera assist video consultation, motors dispense medicines based on doctor's prescription, UV-C light faid sanitization and Cloud database store all the patient's records for future references.

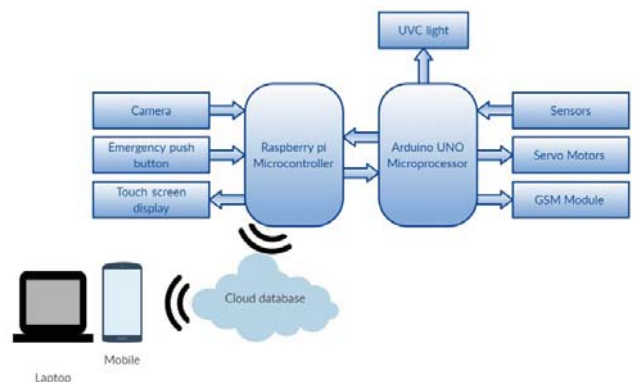

Fig. 2. Block Diagram of the Automatic Health Machine (AHM)

The circuit diagram emphasizes the connections between various sensors, which helps in the operation of the AHM.

The interactive GUI Touch Screen assists the patients to access various services from the AHM. The various sensors are connected to the GPIO pins of the processor. The SMS services from the AHM are carried by the GSM800 sensor. The graphical instructions are displayed on the display to assist every activity with the AHM. While testing the patients using sensors, the instructions follow the flow starting from TFT display to the ARM processor, then to ATMEGA 328 board and Sensors via analog/ digital pins. Various sensors like Ultrasonic sensor, Weight sensors, IR sensor, GSM sensor, IR temperature sensor are used to get the inputs from the patients who are subjected to COVID screening. The Emergency Stop button or the emergency button on the display triggers the signal to ambulance services of the nearby hospital/healthcare centre and starts the GUI for first aid, depending upon the type of emergency given by the bystanders.

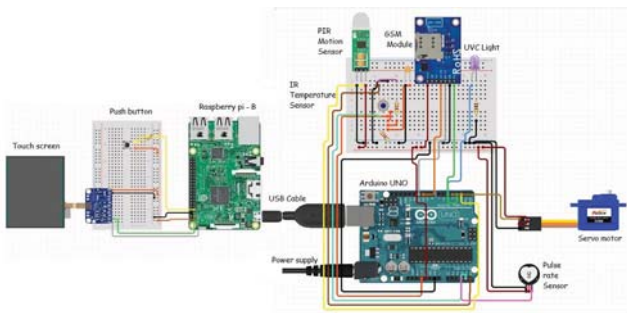

Fig. 3. Circuit Diagram of the Automatic Health Machine (AHM)

V. RESULTS

The AHM is designed using the Solidworks, a solid 3D modeling computer-aided design (CAD) program. The 3D models of the AHM are given in Fig. 4 to Fig. 6 covering the AHM in different views and its enclosure design in Fig.7 respectively.

The AHM is designed with a roof to take the height of the patient during the first registration and AHM are placed inside the enclosure to provide additional privacy to the patient as there generally exists a hesitation to address their illness in public. The Big large display screen is provided with the buttons on the right to provide the option for selection. The AHM can be accessed using the Smart Health Card and PIN or using Fingerprint Scanner to help rural people to access the AHM with ease. The Telephone option provides the facility to connect with the doctor during an online consultation. It also serves as a standby option to connect with doctors if the network connection is poor. The Sensor Kit box provides space to keep all the sensors necessary for the function of the AHM. It is also designed in a way to have an option for printing e-Prescription which is generated after online counselling with the doctor for future reference of the patient. The Sanitation box is fitted with UV-C lights inside to ensure safe sanitation practices before accessing AHM and the Emergency SOS button helps to call an ambulance during emergencies like

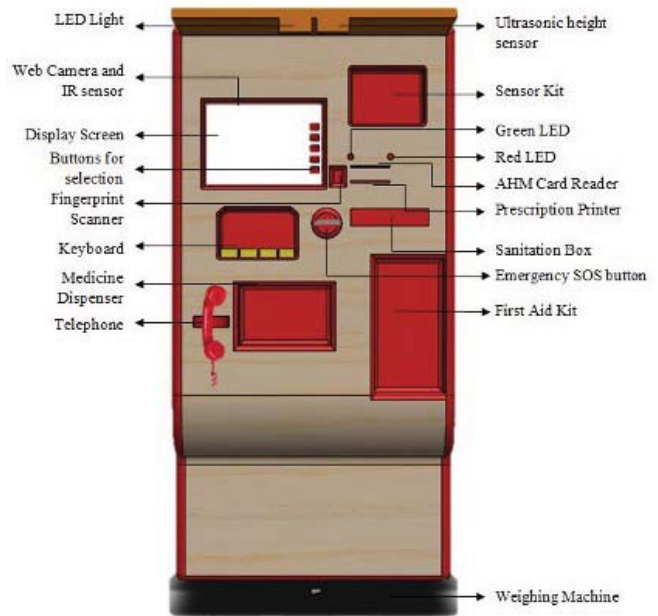

Fig. 4. Front view of the Automatic Health Machine

accidents and the bystanders can provide the first aid to the victim using the First Aid Kit in the AHM.

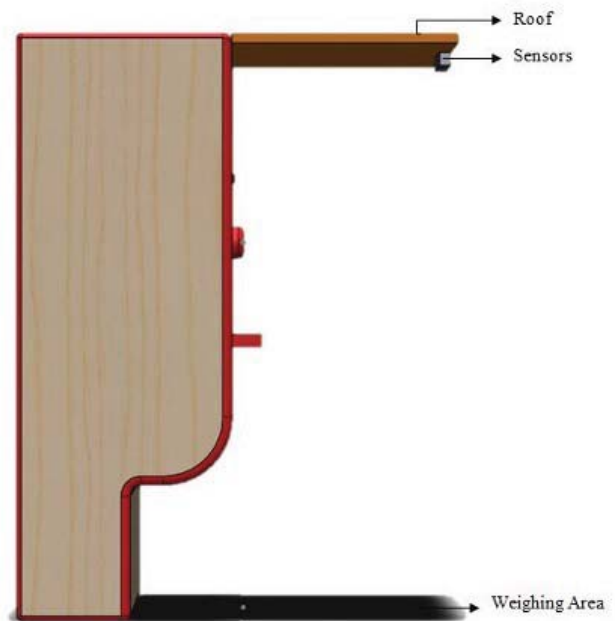

Fig. 5. Side View of Automatic Health Machine

Fig. 5 shows the side view of the AHM showing the provision for light and Height Sensor. The AHM also has the Weighing pad to calculate the weight of the patient. The Back view of the AHM is shown in Fig. 6.



Fig. 6. Back view of Automatic Health Machine

The Enclosure is designed to ensure privacy for the patients during their counselling with the doctors. The Enclosure is designed suitably to have enough space for 2 members in the room. The Enclosure can be of translucent glass material with or without Air Conditioning facility depending upon its installation area. It also practices the habit of treating millions of people by maintaining social distancing.

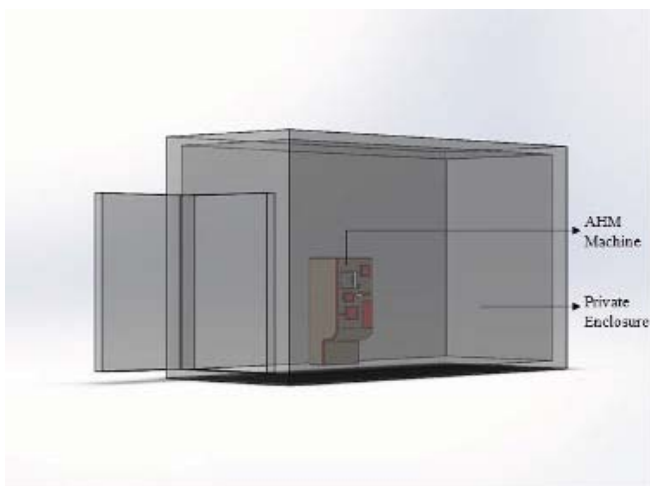

Fig. 7. . Enclosure perspective view of the Automatic Health Machine)

The AHM can be deployed in rural primary healthcare centers, various locations at rural areas where healthcare facilities are very far, quarantined areas, hospitals, COVID testing camps, highways and accident-prone areas. The Ar-

tificial Intelligence based AHM assures the improved speed and accuracy in treating patients and helps nurses and doctors to spend time in treating the patients rather than getting details. The GUI based first aid services and emergency button can save many lives as medications are initiated timely. The complete prototype built is shown in Fig. 8. We conducted virtual workshops with the COVID-recovered patients and frontline nurses and doctors to understand healthcare/patients' requirements considering pandemic and post-pandemic. As an overall outcome, the healthcare professionals feel the system can be adopted in an area where medical facility is not available immediately. Thus, our work has led to a patent being published in India and USA.



Fig. 8. The Prototype Solution of Automatic Health Machine (AHM)

The survey was conducted in various healthcare centers (virtually) between Jun and Sep 2020 only from healthcare professionals' perspectives. The questionnaire included a section on the demographic information, and a section on the AHM requirements. We had 50 responders in total, healthcare professionals in India, out of which 32 were female (64%) and 18 were male (36%). We had 46 professionals (92%) accepted the need of deploying AHM across in India.

## VI. CONCLUSION AND FUTURE WORKS

We believe our system can be deployed not only in hospitals but also in a public setting such as a community center, jail, school, retail store, mall, office building or airport. During this pandemic situation, the use of AHM plays a vital role in treating millions of people by maintaining social distancing. There is also good scope for AHMs in emergency department (ED) in hospitals. Many overseas countries, have benefited by installing this device in accidents and emergency units. Time plays an important factor in treating patients in emergency settings. The time taken to initiate and administer medications to patients in such situations can have a huge impact on patients' outcome. The faster the initiation of medications in the ED hastens the improvement of patients. In cases, such as Meningitis timely initiation of antibiotics to patients can

prevent various complications and save lives. Hence, using new smart technologies like AHMs which aims to improve the efficacy and speed of dispensing medications can be a boon in critical care [8].

#### Advantage of AHMs in rural areas

- Reduced errors and improved quality of healthcare services.
- Wireless, easy to use, web-based interface supporting communication.
- Provision for Telephone to connect during virtual consultation even in case of internet issues or power cut.
- Efficient medical facility 24 x 7.
- Provision of printed e-prescription for future reference.
- Online Booking of appointments for swab test and consultation with a general physician or specialist can be made.
- Quick access to Emergency cases
- Reducing manual steps and helps nurses and doctors to spend more time in treating patients
- Improved patient privacy and security
- Expenses on traveling to the hospitals are greatly reduced
- Provide services like Electronic Medical Record (EMR), Electronic Health Record (EHR), Personal Health Record (PHR) using an ID card.

#### Challenges of AHMs in rural areas

- Need constant maintenance and services of AHM.
- High maintenance and repairing costs can be expected.
- Need proper guidance for the operation of AHM.
- Rural people might hesitate to use.
- Quality of service should be verified to eliminate chances of drug selection and dosing errors.
- A security system is needed as AHM services can be misused.
- Good funding is required to install AHM services as they are expensive.
- Strict regulations and local laws may pose a challenge for installation of AHM.

The COVID situation has increased the need for healthcare professionals and basic healthcare infrastructure in the rural parts of India. The AHMs provide many facilities such as secure medication storage facility, centralized and decentralized drug distribution system and various healthcare facilities [9], [10], tracking patients who availed AHM services [11]. The AHM also supports patients to make appointments or video call with doctors and specialist, emergency services and tracking of COVID patients during hospitalization. All the data of AHM are made available to the management for tracking its usage in different geo-locations. AHM also ensures privacy by placing them inside a private room as a patient demands privacy to address their illness. The AHM is developed using emerging technologies like the Internet of things, Machine Learning, Deep Learning and Artificial Intelligence to provide the necessary healthcare services to the public. In addition to the animated gif displayed in the screen, AHM can be modified by introducing gesture-recognition application for

physiotherapy healthcare and general healthcare [12], [13], [14], [15], [16], and can also be developed for various other applications related to breast care awareness [17], [18].

#### ACKNOWLEDGMENT

We would like to thank our colleagues for their insightful comments and enlightening us with their corporate knowledge.

#### REFERENCES

- [1] L. Goldschmidt and G. L. Goodrich, "Development and evaluation of a point-of-care interactive patient education kiosk," *Journal of telemedicine and telecare*, vol. 10, no. 1\_suppl, pp. 30–32, 2004.
- [2] N. K. Kumar, R. Bhavani, A. Mohan, and D. Vigneswari, "Issk-an integrated self service kiosk for health monitoring and management."
- [3] J. R. Joshi, "Covsack: an innovative portable isolated and safe covid-19 sample collection kiosk with automatic disinfection," *Transactions of the Indian National Academy of Engineering*, vol. 5, no. 2, pp. 269–275, 2020.
- [4] J. Belezina. (2012) Autospense vending machine offers high-security solution for managing medical marijuana. [Online]. Available: <https://newatlas.com/autospense-medical-marijuana-vending-machine/22529/>
- [5] T. S. Randhawa and J. Richards. (2017) Health kiosk. [Online]. Available: <https://patents.google.com/patent/US20120059911A1/en>
- [6] M. Letafat-nejad, P. Ebrahimi, M. Maleki, and A. Aryankhesal, "Utilization of integrated health kiosks: A systematic review," *Medical Journal of The Islamic Republic of Iran (MJIRI)*, vol. 34, no. 1, pp. 772–784, 2020.
- [7] S. Jacob and V. Menon, "Medico-a simple iot integrated medical kiosk for the rural people," 2019.
- [8] D. Ganesh, G. Seshadri, S. Sokkanarayanan, P. Bose, S. Rajan, and M. Sathiyarayanan, "Method and automated health machine for providing healthcare services to patients using iot," Patent 202 041 047 240, 2020.
- [9] D. H. Wilson, "Assistive intelligent environments for automatic health monitoring," in *Robotics Institute*. Carnegie Mellon University, 2005.
- [10] D. Ganesh, G. Seshadri, S. Sokkanarayanan, P. Bose, S. Rajan, and M. Sathiyarayanan, "Autoimpilo: Smart automated health machine using iot to improve telemedicine and telehealth," in *2020 International Conference on Smart Technologies in Computing, Electrical and Electronics (ICSTCEE)*. IEEE, 2020.
- [11] F. Slack and J. Rowley, "Online kiosks: the alternative to mobile technologies for mobile users," *Internet research*, vol. 12, no. 3, pp. 248–257, 2002.
- [12] T. Mulling and M. Sathiyarayanan, "Characteristics of hand gesture navigation: a case study using a wearable device (myo)," in *Proceedings of the 2015 British HCI Conference*. ACM, 2015, pp. 283–284.
- [13] M. Sathiyarayanan and T. Mulling, "Map navigation using hand gesture recognition: A case study using myo connector on apple maps," *Procedia Computer Science*, vol. 58, pp. 50–57, 2015.
- [14] M. Sathiyarayanan and S. Rajan, "Myo armband for physiotherapy healthcare: A case study using gesture recognition application," in *Communication Systems and Networks (COMSNETS), 2016 8th International Conference on*, Jan 2016, pp. 1–6.
- [15] M. Sathiyarayanan and S. Rajan, "Understanding the use of leap motion touchless device in physiotherapy and improving the healthcare system in india," in *Communication Systems and Networks (COMSNETS), 2017 9th International Conference on*, Jan 2017.
- [16] D. Ganesh, G. Seshadri, S. Sokkanarayanan, S. Rajan, and M. Sathiyarayanan, "Iot-based google duplex artificial intelligence solution for elderly care," in *2019 International Conference on contemporary Computing and Informatics (IC3I)*. IEEE, 2019, pp. 234–240.
- [17] M. Sathiyarayanan and S. Rajan, "Breast cancer awareness through smart mobile healthcare applications from indian doctors perspective," in *Proceedings of the International conference on Smart Technologies for Smart Nations, Symposium on Smart Health Care Applications (SHCA 2017)*. IEEE, 2017.
- [18] S. Rajan, M. Sathiyarayanan, S. Prashant, S. Prashant, and P. Nataraj, "Prevention of avoidable blindness and improving eye healthcare system in india," in *Communication Systems & Networks (COMSNETS), 2018 10th International Conference on*. IEEE, 2018, pp. 665–670.