

Remote Controlled Laboratory Experiments for Engineering Education in the Post-COVID-19 Era: Concept and Example

Amr Karam Mohammed
Department of Electrical Power and
Machines Engineering
Faculty of Engineering at Helwan
Helwan University
Cairo, Egypt
amr.karam977@gmail.com

Helmy M. El Zoghby
Department of Electrical Power and
Machines Engineering
Faculty of Engineering at Helwan
Helwan University
Cairo, Egypt
helmy_028123288@yahoo.com

Mahmoud M. Elmesalawy
Department of Electronics and
Communications Engineering
Faculty of Engineering at Helwan
Helwan University
Cairo, Egypt
melmesalawy@h-eng.helwan.edu.eg

Abstract — The worldwide outbreak due to COVID-19 pandemic lead to a major change in the life style in general and in the education system in specific. To help contain the impacts of COVID-19, universities and schools need to strongly shift to various electronic education models such as online learning, distance learning and blended learning. One of the crucial models that support the success of distance learning especially in engineering education is the remote-controlled experimentations, which allow students to execute the required practical work in a similar way as it conducted in the physical laboratories if it is appropriately designed. This paper introduces an integrated solution for improving the remotely controlled working on the educational laboratory experiments for electrical engineering sector. The proposed solution consists of four main components: Internet of remote-controlled things that represent the required experimentation devices, cloud platform, TCP/IP Internet communication connection, and finally the control and monitoring application. A complete experiment for phasor measurement unit (PMU) system as an example is deployed in the university laboratory with its all components which is completely controlled and managed remotely from the home through Internet. PMU is installed in a prototype of electrical substation with different types of loads. All required experimental data and results are successfully obtained and controlled through the developed system with the required accuracy and performance.

Key Words: - Remote, distance learning, Smart, Wi-Fi, phasor measurement units, substations, Real Time, Labview™

I. INTRODUCTION

In recent years, research about different techniques for remote-controlled laboratories is one of the topics that has been attracted many of the researchers and companies especially at these days after the outbreak due COVID-19 pandemic. Actually, practical experimentation is considered one of the most critical gaps that facing the success of distance learning process in schools and universities. So, it is necessary to focus on the development of efficient and reliable remote-controlled laboratories to accommodate the practical parts in the entire educational courses and programs [1]-[2]. Remote experimentation arises from different motivations: It allows teachers to better demonstrate physical concepts during a

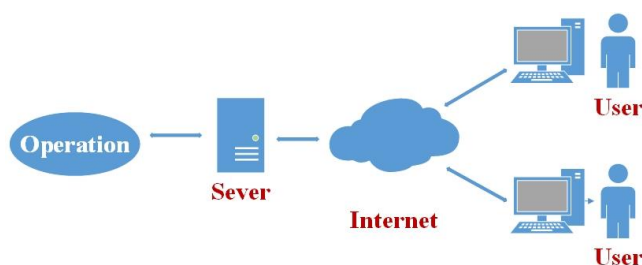

Fig.1 Main topology for a typical remote-controlled experiment.

traditional lecture, by simply connecting to the remote lab and running the experiments. It can also provide an economic solution for distance learning courses in engineering fields as shown in Fig. 1.

With the new university environment due to COVID-19 and also with the absence of sufficient laboratory resources at some remote sites, the usual practice is as follows: either replace the exercises with virtual laboratories or develop remote controlled laboratory experimentation environment. A virtual laboratory can be defined as an environment in which experiments are conducted or controlled partly or wholly through computer operation, simulation, or animation either locally or remotely via the internet. It also allows users to direct the process and the end product with some controllable variables of the experiment in the software. In this case, the experiment is often a graphical simulated model of the actual experiment. This type of virtual laboratory does not include physical hardware, but it allows the user to observe the process and the end product through animation or simulation. However virtual laboratories can enhance students' enthusiasm for learning through interactivity and students can redo their experiments.

Replacing experiments with virtual exercises is not an ideal solution since physical laboratory exercises are a vital component of any educational curriculum especially in major field of engineering, and other sciences [3]-[4]. Students should work on physical equipment and systems to acquire the necessary skills such as analysis, creativity, teamwork,

learning from failure and communication skills required for an engineering profession. These objectives create one of the greatest challenges in the development of remote laboratories. Students should have the same feeling of using real equipment and systems as in traditional hands-on laboratories. This sense of genuineness can be improved with the help of some kind of audio or visual feedback to enhance the student's interaction with the laboratory equipment. The second issue usually discussed, is that remote laboratories are compared with simulation and hands-on laboratories with real instruments in terms of their effectiveness. This comparison is inconclusive as each laboratory has its own merits, scope and limitations. Simulations and modelling tools require huge computing resources and are limited to simplified models ignoring real world complexities [5]-[6]. Traditional laboratories with real equipment are expensive and are available to students for limited time. So remote-controlled laboratories are the solution for all these problems in which students can gather real data from the experiment field which are necessary for them to be involved in the experiments as in the reality.

This paper illustrated a simple and cheap methodology to facilitate the techniques of achieving the remote-controlled laboratories for the engineering education and apply this methodology on a case study focused on the electrical engineering field using simple products provided on the market. Students can work on it, practice their experiments easily and implement new ideas for increasing the scale of their laboratories.

II. SYSTEM DESIGN ARCHITECTURE

The proposed system design architecture consists of the following components:

A. Remote Access Service

Remote access is the ability for an authorized person to access a computer or a network from a geographical distance through a TCP/IP network connection. By using remote desktop software, you can capture the mouse and keyboard inputs from the local computer (client) and sends them to the remote computer (server). The remote computer in turn sends the display commands to the local computer. Remote desktop sharing is accomplished through a common client/server model. The client, or virtual network computing (VNC) viewer, is installed on a local computer and then connects via a network to a server component, which is installed on the remote computer. In a typical VNC session, all keystrokes and mouse clicks are registered as if the client were actually performing tasks on the end-user machine [7]-[8].

B. Switching Matrix

The switching matrix provides remote switching of the various experimental components. Switching methodology is one of the most common functions in the electronic systems. It allows for the configuration of different experimentation topologies and configuration through a remote-controlled platform. Switching matrix is made up of electronic switches

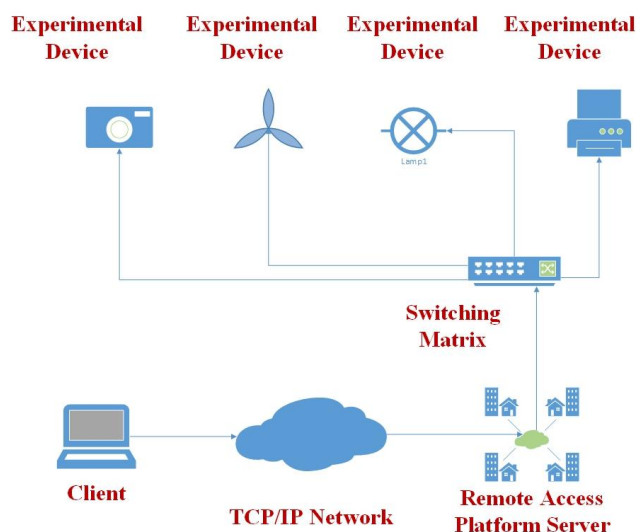

Fig. 2 Remotely Controlled System Architecture.

and signal conditioners that are in the same mechanical housing. The switches and signal conditioners can be interconnected with cables. The switch matrix then employs a driver circuit with power supply to power and drive the switches and signal conditioners. The switch matrix uses connectors or fixtures to route the signal paths from the sourcing and measurement equipment to the device under test. The purpose of a switch matrix is to move the signal routing and signal conditioning to one central location in the test system versus having it all distributed at various places in the test system.

C. Experimental Devices

Experimental devices are the whole components under test in the experiment or components which has a vital role to complete the experiment such as electrical loads, mechanical loads, sensors, transducers and cameras which provide a physical seen for the remote laboratories and conducting the procedures remotely.

III. CASE STUDY: SUBSTATION MONITORING AND CONTROL USING PHASOR MEASUREMENT UNIT (PMU) SYSTEM

The proposed methodology will be applied on a practical application focused on the electrical power engineering field.

A. Purpose of the experiment

The purpose of the experiment is to apply the concept of substation digitalization and how it can be towards digitalization in the electrical power engineering field through distributing specified number of PMUs phasor measurement units into the electricity grid then gathering time stamped synchrophasor measurements with different types of loads remotely, also through applying the interlocking schemes which are very important for substation operation.

B. Phasor measurement unit concept

Phasor measurement unit is the base component of Wide Area Monitoring System (WAMS) which is capable of measuring the voltage magnitude and phase angle at every system bus of the power system, and the current magnitude and phase angle at every branch (lines, transformers and other series elements) as shown in Fig. 3. All of these measurements are synchronized through the GPS base timing to complete the picture of the functioning electricity grid [9]-[11]. The data in each PMU is time-synchronized via Global Positioning System (GPS) receivers – to an accuracy of one microsecond – and aggregated in the Phasor Data Concentrator (PDC) several times a second according to IEEE C37.118 for WAMS solutions.

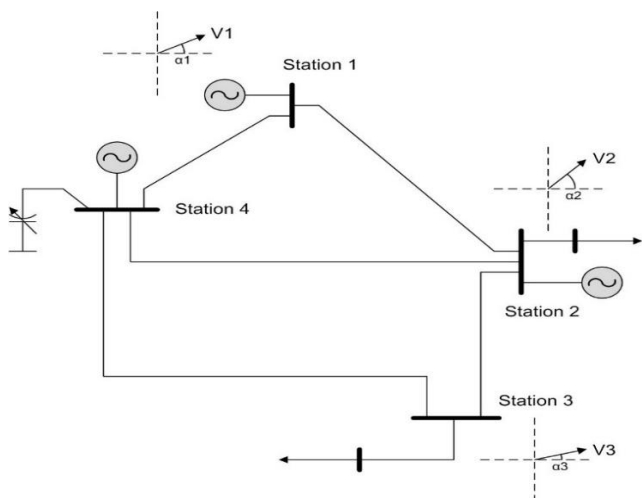

Fig. 3 Electrical Power System Network Example.

C. System Components

As shown in Fig.4, the hardware components needed to configure the experiment are: -

a) Switching Matrix (Sonoff R2 4CH)

Using any smart switch, local and remote-control functions can be applied. Sonoff smart Wi-Fi switch which is a 4-channel din rail mounting 433MHz RF remote Wi-Fi switch that can independently control the 4 home appliances. It supports switching among 3 working modes: inching/interlock/self-locking mode. Sonoff Basic is an affordable Wi-Fi smart switch that provides users with smart home control. It is a remote-control power switch that can connect to a wide range of appliances. Sonoff Basic Wi-Fi electrical switch transmits data to a cloud platform through the Wi-Fi Router, which enables users to remotely control all the connected appliances, via the mobile application eWeLink. The server is Amazon AWS global server. Sonoff Wi-Fi controlled switch makes all appliances smart. As long as the mobile phone has network (2G/3G/4G/Wi-Fi), users can remotely control the appliances by turning ON/OFF

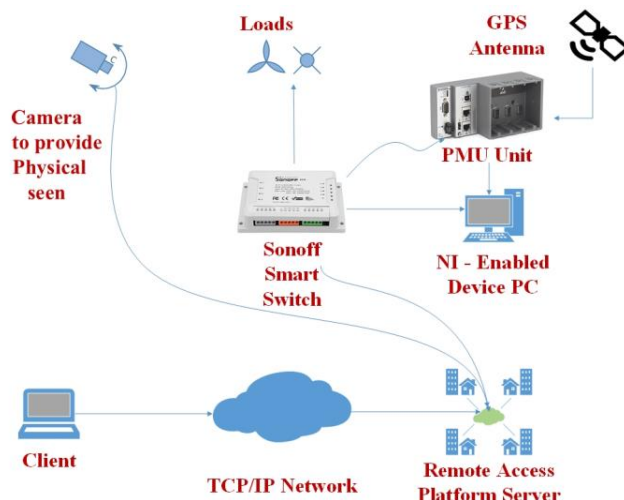

Fig.4 Illustrated Remotely Controlled Example Architecture.

set timers for the appliances, which can include countdown/scheduled/loop timers, and can thus, help users maintain an easy life. The mobile application eWeLink enables users to control the appliances easily. The iOS version of the application can be downloaded in App Store while the Android version in Google Play.

b) Phasor Measurement Unit (PMU)

Phasor measurement unit provided from National Instruments company which consists of: - cRIO 9065 Compact Controller which Combines a processor running NI Linux Real-Time, a programmable FPGA, and modular I/O with vision, motion, and display capabilities. This controller runs NI Linux Real-Time, which combines the performance of a real time OS with the openness of Linux. You can use LabVIEW™ to create, debug, and deploy logic to the Xilinx FPGA and ARM or Intel processor.

NI 9242 which is a 250 Vrms L-N, 400 Vrms L-L, 50 kS/s/ch, 24-Bit, 3-Channel C Series Voltage Module. The NI-9242 performs single-ended analog input. The wide measurement range makes it ideal for high-voltage measurement applications such as phasor measurements, power metering, power quality monitoring.

NI 9227 which is a 50 kS/s/ch, 5 Arms, 24-Bit, 4-Channel C Series Current Module. The NI-9227 was designed to provide high-accuracy measurements to meet the demands of data acquisition and control applications. It includes built-in anti-aliasing filters. When used with a C Series Voltage Input Module, the NI-9227 can measure power and energy consumption for applications such as appliance and electronic device test.

NI 9467 GPS C Series Synchronization Module which provides accurate time synchronization for CompactRIO systems. System designers can use this module for accurate data timestamping, system clock setting, gating data acquisition based on the arrival of the PPS, and synchronizing global waveform acquisition data using the FPGA (Field use with the Board-Mounted GPSDO . A GPSDO locked to the

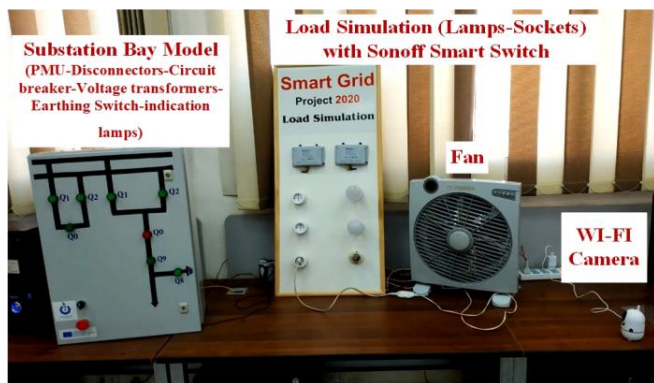

Fig.5 System Hardware Components (Substation Model Kit - Load Simulation - WI-FI Camera- PC).

GPS constellation can provide time synchronization within 50 ns of the global GPS standard and very high clock accuracy. Programmable Gate array). 5Volt Active GPS Antenna, Magnetic mount, this is a 5V active GPS antenna intended for

c) Experimental Devices

Wi-Fi camera is used for providing a physical seen for the whole components located in the laboratory as shown in Fig.5, also different kinds of Resistive and reactive loads for gathering different types of data from the PMU.

D. Practical connections

The panel shown in Fig.6 is considered as a substation kit which will be controlled remotely. It simulates one bay of the main components of any electrical substation in the high voltage level such as disconnector switches, circuit breakers, voltage transformers, current transformers.

A phasor measurement unit is added into the panel for gathering time-stamped measurements (voltage phasor and current phasor). PMU has a vital role in the wide area monitoring systems so it is subjected into the electrical substation then data can be transferred to the control center according to IEEE C37.118.

IV. RESULTS AND DISCUSSION

To verify the performance of the system, some practical experiments have been carried out.

A. Substation Interlocking

Switching schemes of substations determine the electrical and physical arrangement of the switching equipment. Different switching schemes can be selected as emphasis is shifted between the factors of security, economy, extendibility, maintainability, operational flexibility, protection arrangement, short circuit limitations, land area, safety and simplicity dictated by function and importance of the substation. Interlocking logical checking rules According to the anti-misoperation regulations, interlocking logical rules about circuit breakers, disconnectors, ground disconnectors and earthing switch is analyzed. According to the basic principles of interlocking logic and primary equipment topology, interlocking logic rules checking methods are mainly as follows in [12]-[14].

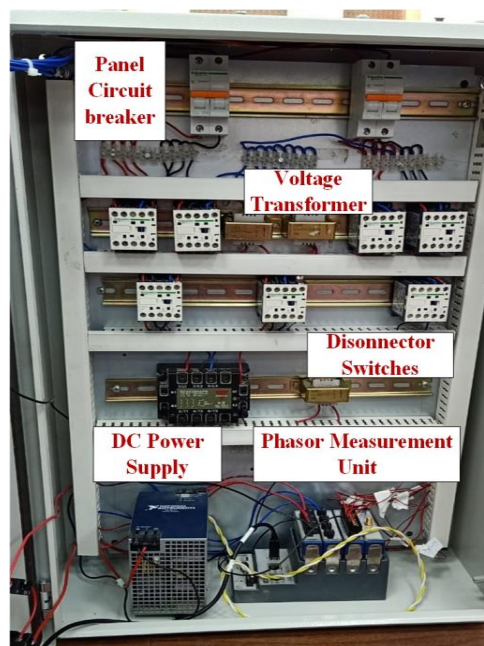

Fig.6 Application Panel Components

LabVIEW makes it easy to develop the system due to its graphical nature, now substation model can be run remotely by clicking on every switch obtained on the control panel as shown in Fig. 7,8 according to the interlocking schemes which protect substations from any operation mistakes.



Fig.7 Interlocking Schemes Using LabVIEW for Double Bus Bar Single Breaker Substation Scheme and View from the Lab.



Fig.8 Interlocking Schemes Practical Experiment Using LabVIEW and View from the Lab.

B. Phasor Measurement Unit Output

PMU can identify its location using the GPS module integrated on it so measurements as shown in Fig.9 illustrate Location of the university and the laboratory which has a coordination of (Latitude of 29.852^o – longitude of 31.342^o – elevation of 13.547 m).



Fig. 9 Phasor Measurement Unit Output Data

As shown also voltage phasor and current phasor are timestamped through the reference timing from the GPS module. Measurements are related with the load conditions. To simulate the electrical power system behavior, different cases of different loads can be applied then real time measurements can be gathered from the PMU.

Test Case 1

Lamp 1 can be turned on remotely as shown in Fig. 10 then conducting timestamped measurements from the PMU as shown also in Fig. 11. Voltage measured is 10.6323V because voltage transformer with turns ratio of 220/10 is connected before the voltage module, the current drawn also is equal to 0.011A with low power factor of 0.403. The LED lamp is not a resistive load.



Fig. 10 Load 1 is Turned on Remotely.

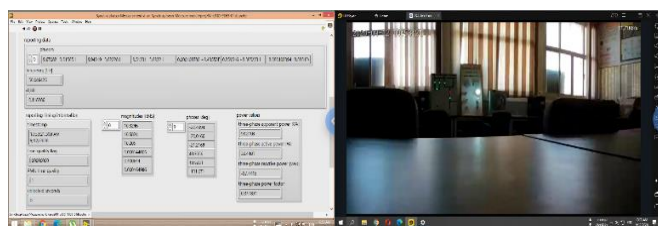

Fig. 11 PMU Measurements from Load 1 .

Test Case 2

Lamp 2 can be also turned on remotely as shown in Fig. 12 then conducting timestamped measurements from the PMU as shown also in Fig. 13. Voltage measured is going to be the same value of 10.6238V the current drawn has changed because another load is connected so, the total current drawn is equal to 0.023A with also low power factor of 0.383 because also the two LED lamps also are not resistive loads.



Fig. 12 Loads 1,2 are Turned on Remotely.

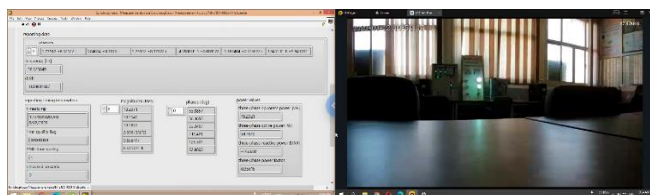

Fig. 13 PMU Measurements from Load 1 and 2.

Test Case 3

Lamp 3 and Fan can be also turned on remotely as shown in Fig. 14 then conducting timestamped measurements from the PMU as shown also in Figs. 15 and 16. In this case 100W resistive lamp and 300W fan are added into the circuit. Voltage has a value of 10.6573V on the first busbar, 10.9164V on the second busbar and 10.6022V on the load terminals, current drawn has been increased to equal 2.18A with overall power factor of 0.97 as shown in Fig. 15,16.



Fig. 14 Loads 1,2,3,4 are Turned on Remotely.

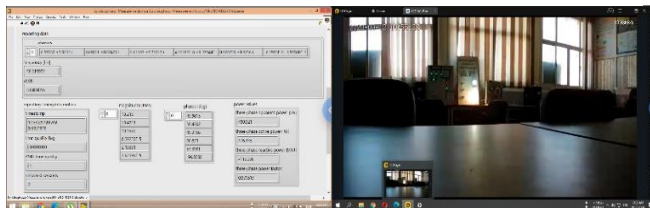

Fig. 15 PMU Measurements from Load 1,2,3 and 4.



Fig. 16 PMU Detailed Measurements.

Noticed that, there is no phase shift or difference between every two phases as shown in Fig. 17 because the same power source is used but if three phase power source is used as shown in Fig. 18, phase shift of 120° will be existed between every two phases. PMU can also detect frequency and Rate of change of frequency ROCOF as shown in Fig. 19.

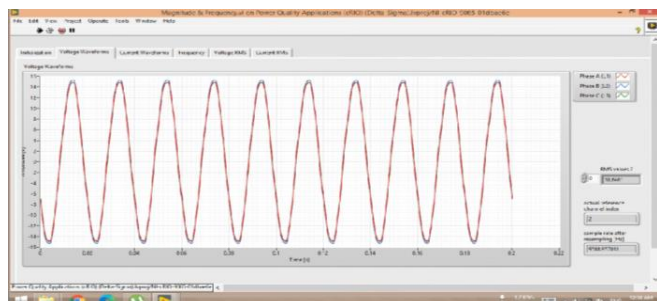

Fig. 17 Voltages Waveforms in case of Single-Phase Power Source.

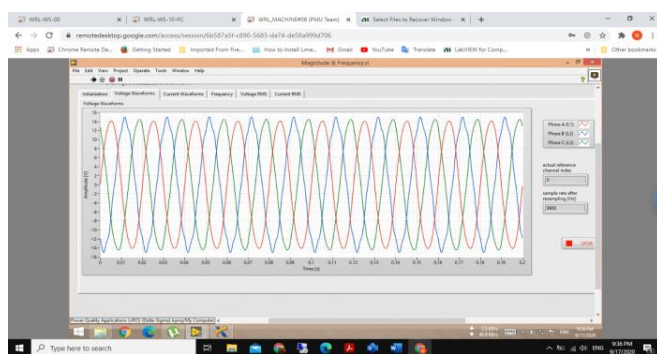

Fig. 18 The three phase voltage waveforms in case of Three-Phase Power Source.

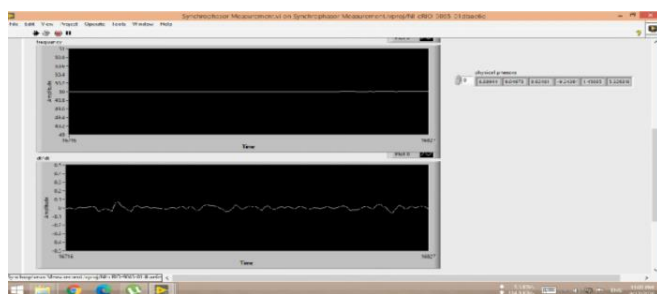

Fig. 19 Frequency and Rate of Change of Frequency (ROCOF).

V. CONCLUSION

In this paper, the concept and example for an easy and cheap method for remotely controlled laboratory is proposed and developed using simple components with suitable PC remote access and smart Wi-Fi switch. By using this system, students can practice the experiments from any location at any time remotely through Internet connected computer client. A phasor measurement unit (PMU) based experiment is designed and implemented as an example for the remote laboratory to proof the developed concept and the efficiency of the system.

The system is tested in which all required experimental data and results are successfully obtained and controlled through the developed system with the required accuracy and performance.

ACKNOWLEDGMENT

This work was supported by Erasmus+ Program through the funded project "Smart Grid Technology – A Master Program/SGT-MaP" and by the Academy of Scientific Research and Technology (ASRT) through graduation project support program.

REFERENCES

- [1] Felgueiras, Ricardo Costa et al., "A sustainable approach to laboratory experimentation", Technological Ecosystems for Enhancing Multiculturality 2019 (TEEM'19), October 2019.
- [2] Zhao, Liang, and Guangwen Wang. "Design and Implementation Remote Monitoring System for Paving Machine Based on IoT." 2020 6th International Conference on Information Management (ICIM). IEEE, 2020.
- [3] Costa, Ricardo, Francisco Pérola, and Carlos Felgueiras. "µLAB A remote laboratory to teach and learn the ATmega328p µC." 2020 IEEE Global Engineering Education Conference (EDUCON). IEEE, 2020.
- [4] Yuan, Ye, et al. "Communication Scheme of Cloud Platform for the Lower Limb Exoskeleton Rehabilitation Robot." 2020 17th International Conference on Ubiquitous Robots (UR). IEEE, 2020.
- [5] S. Gröber, Vetter, M., Eckert, B. and H.-J. Jodl, "Experimenting from a Distance," European Journal of Physics, vol. 28, 2007
- [6] J. a. C. K. Henry, "Improving Laboratories with Internet Controlled Equipment and Student Support," in The 2000 ASEE Southeastern Section Conference, Roanoke, Virginia, 2000.
- [7] H. Shen, Xu, Z., Dalager, B., V. Kristiansen, Strøm, Ø., Shur, M., Fjeldly, T., Lü, J. and T. Yterdal, "Conducting Laboratory Experiments over the Internet," IEEE Transactions on Education, 2000.
- [8] K. Hamza, Alhalabi, B. and D. Marcovitz, "Remote Labs!," in Society for Information Technology and Teacher Education International Conference 2000, Chesapeake, VA, 2000.
- [9] Dong, Jianning, et al. "Online Laboratory Sessions for the Education of Electrical Machines and Drives." 2020 IEEE 29th International Symposium on Industrial Electronics (ISIE). IEEE, 2020.
- [10] Milojević, Vladimir, et al. "Utilization of PMU measurements for three-phase line parameter estimation in power systems." IEEE Transactions on Instrumentation and Measurement 67.10 (2018): 2453-2462.
- [11] Hampannavar, Santoshkumar, et al. "Performance Improvement of M-Class Phasor Measurement Unit (PMU) using Hamming and Blackman Windows." 2020 IEEE International Conference on Power Electronics, Smart Grid and Renewable Energy (PESGRE2020). IEEE, 2020.
- [12] Zhang, Haidong, et al. "The Technology for Substation Interlocking Logic Automatic Checking Based on IEC 61850." 2018 China International Conference on Electricity Distribution (CICED). IEEE, 2018.
- [13] Man, Tsang Kui, and Ng Pang Yiu. "Goose interlock overcurrent protection for 11KV double-busbar substation." (2015): 36-6.
- [14] Sarry, S. V., P. S. Kireev, and A. V. Ukrainsev. "Intelligent Interlocking of Switching Devices." 2018 International Multi-Conference on Industrial Engineering and Modern Technologies (FarEastCon). IEEE, 2018.