









Backscatter Communications

RICARDO TORRES ^{1,2,3} (Student Member, IEEE), **RICARDO CORREIA** ^{2,3,4} (Member, IEEE),
NUNO BORGES CARVALHO ^{1,2} (Fellow, IEEE), **SPYRIDON DASKALAKIS**⁵ (Member, IEEE),
GEORGE GOUSSETIS ⁵ (Senior Member, IEEE), **YUAN DING** ⁵ (Member, IEEE),
APOSTOLOS GEORGIADIS⁵ (Fellow, IEEE), **ALINE EID** ⁶ (Student Member, IEEE),
JIMMY HESTER ⁶ (Member, IEEE), AND **MANOS M. TENTZERIS** ⁶ (Fellow, IEEE)

(Invited Paper)

¹Departamento de Eletrónica, Telecomunicações e Informática, Universidade de Aveiro, Aveiro 3800, Portugal

²Instituto de Telecomunicações, Aveiro 3800, Portugal

³CISeD - Research Centre in Digital Services, Polytechnic of Viseu, Viseu 3500, Portugal

⁴Sinuta S.A, Estarreja 3860, Portugal

⁵School of Engineering and Physical Sciences, Heriot-Watt University, Edinburgh EH14 4AS, U.K.

⁶School of Electrical and Computer Engineering, Georgia Institute of Technology, Atlanta, GA 88410 USA

CORRESPONDING AUTHOR: Ricardo Torres (e-mail: ricardo.torres@ua.pt).

ABSTRACT This paper addresses backscatter communications as a new paradigm for Internet of Things (IoT) sensor wireless solutions. The paper clearly presents the history background of the technology and then makes a summary of the more recent developments from several groups around the world, with emphasis in US and Europe groups. The analysis done in this paper will address circuit and physical layer approaches for such a solution and its real implementations, having in mind IoT sensors for long range high speed communications.

INDEX TERMS Backscatter, wireless communications, electromagnetic harvesting, IoT.

I. INTRODUCTION

Backscatter communications are a change in paradigm that will shape the face of Internet of Things (IoT) communications in the near future. Radio Frequency (RF) Backscatter was proposed initially as a spy device with a great idea for modulating an RF signal [1], and from them to know it has travelled a great path for implementing commercial and non-commercial solution, being Radio Frequency Identification (RFID) transponders the most important commercial devices. In this paper we will present the work done by several groups in US and Europe in order to substitute the traditional communication architectures in IoT devices.

The novelties discussed in the paper addresses very high speed backscatter solutions based on higher order modulations, which will allow near 1 Gbps transmission with these approaches. Millimeter Wave (mmWave) backscatter sensors, ambient backscatter, where the RF signal is re-used from available commercial RF signals not thought to be backscattered at first, all digital approaches, allowing to connect antennas directly to the digital Integrated Circuit (IC)'s and very long range backscatter approaches.

The authors expect that this could be a good source of information for research-oriented works using the new backscatter paradigm to build improved IoT sensors.

This paper is divided into several sections. Section II presents the history background of backscatter radio or communication; Section III exposes some different combinations in backscatter communication: backscatter communication combined with Wireless Power Transfer (WPT) capabilities in Section III.A, in Section III.B backscatter communication is combined with high order modulation, and in Section III.C it is presented towards GBPS transmission or ultra highbit rate backscatter modulators. Section IV presents ambient backscatter and is divided into two sections. The first one shows us the spectrum opportunities able to perform backscatter communication, and the last one shows several ambient backscatter systems. Section V describes works on analog backscatter. Then, all-digital backscatter systems are presented in Section VI. Section VII exposes ultra-long range backscattering communication in two sub-sections, Section VII.A is mm-Wave backscattering-enabled (mmID) communication and localization, Section VII.B exposes tunnel

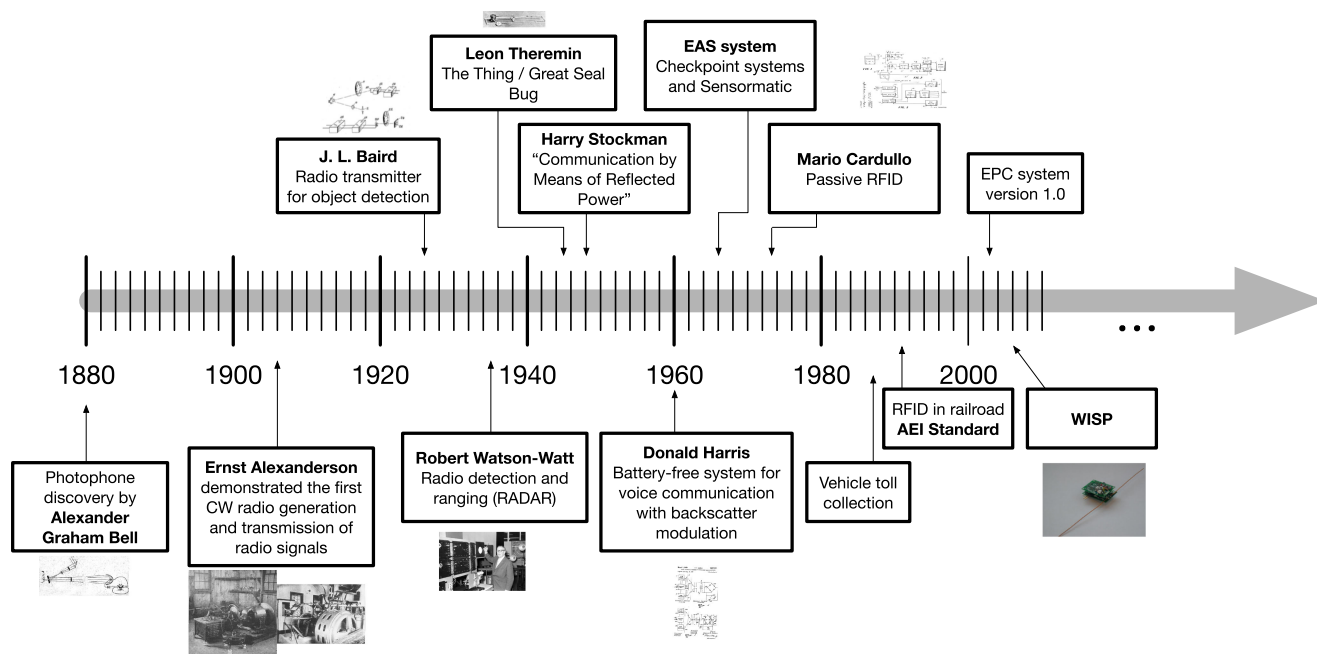

FIGURE 1. History of RFID and backscatter communication.

diode-based backscattering communication and Section VIII presents reading backscatter signals with legacy devices. Finally, Section IX presents the discussion about the potential, limitations and applications of the technologies presented and the conclusions are drawn in Section X.

II. HISTORY

The principle of communication by reflection was first discovered in 1880, with the photophone developed by Alexander Graham Bell [2]. The objective of the system was to perform speech communication based on a beam of light, in which the sound waves were projected through an instrument to the mirror and by its vibration, a modulation was performed in the reflected beam of light. By demodulating the received signal at the receiver, it was possible to reproduce the transmitted signal. This tests were performed at a distance of 213 meters. In 1945, a spy listening device was developed by Leon Theremin and was inside the Great Seal of the United States [1]. This device was used from the Soviet Union to spy on the US embassy in Moscow and consisted in a monopole antenna connected to a resonant cavity with a flexible sound-sensitive conductive membrane. The changes from the membrane caused different antenna's load and through this it was possible to radiate the device with a RF Continuous Wave (CW) signal and demodulate the reflected wave originated by the voices of those present in the room.

In 1948, Harry Stockman presented the principle of communication with the use of reflections generated by mechanical devices, which included audio transfer over microwave frequencies [3]. Nowadays, the modern tags use similar modulated backscatter operating principles. These concepts contributed to the evolution of commercial applications based on

backscatter communication. This technology when combined with WPT can enhance many technologies, as Donald B. Harris did in 1960 when proposed a battery free system for voice communication based on backscatter radio and WPT, [4]. This advancement contributed to the development and growth of Radio Frequency Identification (RFID) technology. In this decade, the companies began commercializing anti-theft systems that used radio waves to determine whether an item had been paid for or not. The 1-bit Electronic Article Surveillance (EAS) tags were used for counter-theft and were the first large scale use of RFID concept [5]. Moreover and with the appearance of the Wireless Identification and Sensing Platform (WISP) [6], which is a wireless, battery-free platform for sensing and computation that is powered and read by an UHF RFID reader with the capability of sensing the environment it encouraged the scientific community to research on the backscattering-based sensing. Some other commercial applications used the technology for inventory management, for the automotive industry, for the location of livestock and wildlife, for anti-theft in the retail trade, for keys and electronic documents, and in agriculture and nature reserves [7]. The author, in [8], shows that it is impossible to cover a field now as vast as the RFID industry as the author of [9] shows some of the latest RFID sensor applications for IoT applications. Fig. 1 presents the major milestones of RFID technology.

III. DIFFERENT COMBINATIONS IN BACKSCATTER COMMUNICATION

A. BACKSCATTER COMMUNICATION WITH WPT CAPABILITIES

The passive tags are energized through the reader and thus are responsible for the modulation of the incoming wave.

To improve the RFID tag in order to have the possibility to store data or to increase the computing capabilities, a careful design embedded with WPT capabilities should be considered. This integration has enabled the interest in the concept of passive wireless sensors, which will have an important role when considering an Internet of Things (IoT) scenario with a lot of sensors deployed everywhere sensing the environment without the need of having batteries in each sensor. Nowadays, the increase of IoT sensors will imply the heighten of batteries to be deployed, which will have a negative ambient impact. As it was mentioned previously, battery-powered tags can improve the distance of communication but have some limitations when referring to the battery cost and its replacement. Thus, the alternatives to the battery systems are based on EH technology or other different sources (solar [10], motion or vibration [11], ambient RF [12]). To overcome the problems from the EH and batteries, the concept of WPT was explored to supply the tags with power.

In [14], a solution combining inductive WPT and Ultra High Frequency (UHF) RFID was presented and it was shown that using both the inductive WPT and UHF RFID it was possible to increase the tag sensitivity by 21 dB. However, the major problem of using inductive WPT is the proximity between the tag and the power source. Regarding electromagnetic WPT, a comparison between different rectifier topologies and different stage levels was presented in [15]. The obtained results show a high dependence between the received power and the most efficient topology. In [16] the authors presented a structure with a two-tone signal at 1.8 GHz and 2.4 GHz, which improved the voltage output in 20% higher in average when comparing with a single-tone input. The work in [17] presents a reader that is configured to transmit power in CW. The tag uses a storage capacitor that is able to charge up to 5.5 V after the rectification. After the storage capacitor is charged, it powers the tag that performs sensing and communication, reflecting the carrier wave. This process was proven at a distance of 1 m between the reader and tag. The same principle was used in [18].

The work in [13], [19], as can be seen in Fig. 2, presents a solution using dual band wireless power and data transfer. In this solution, two frequencies were considered: one was used to power the tag and the other to perform the communication through backscatter. A similar approach, using different frequencies for energy and communication was presented in [20]. In that work, a different circuit for the RF-DC conversion was used for each frequency. The work in [21] used two different frequencies for RF communication and WPT. The authors used 5.8 GHz to power up a portion of radio that is connected to a battery with an RF-DC converter, which will only activate the battery for the main transceiver as a Wake-on Radio (WOR). Nevertheless, the system is not passive and uses the WPT to activate the main transceiver. Despite of having passive tags for communication, it is utmost important to improve the data rate in the sensors in order to reduce the power consumption and extend read range.

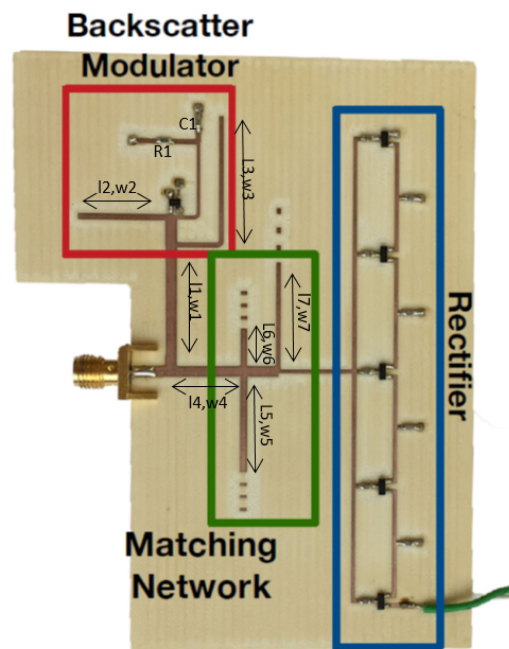

FIGURE 2. Photograph of implemented system with backscatter modulator combined with WPT. Elemented system with backscatter modulator combined with Wireless Power Transmission (WPT). Element values are $L1 = 21.2$ mm, $W1 = 1.87$ mm, $L2 = 15.1$ mm, $W2 = 1.0$ mm, $L3 = 21.9$ mm, $W3 = 0.8$ mm, $L4 = 11.3$ mm, $W4 = 1.87$ mm, $L5 = 17.1$ mm, $W5 = 1.2$ mm, $L6 = 6.7$ mm, $W6 = 1.1$ mm, $L7 = 18.6$ mm, $W7 = 0.7$ mm, $R1 = 50$, and $C1 = 47$ pf. Substrate for the transmission lines is Astra MT77, thickness = 0.762 mm, $\epsilon_r = 3.0$, $\tan \delta = 0.0017$. Original Source: [13].

B. BACKSCATTER COMMUNICATION WITH HIGH ORDER MODULATION

Technological advancements increased the data transmission so, the basics modulations, such as Amplitude Shift Keying (ASK), Phase Shift Keying (PSK) and Frequency Shift Keying (FSK) become insufficient, which originated higher-order and multi-level modulation. This type of modulation can withstand high-intensity data transmission in a broader range of applications, and the required data rate will depend on the application or scenario.

N-ASK, N-FSK and N-PSK can represent more symbols through different values of amplitude, phase or frequency. The N variable represents the modulation order, and in the case of N-ASK, the number of signal amplitude levels the number of symbols that can be represented. In the case of N-PSK, for example, when N is 4, it is possible to represent four symbols with four different phase values. For N-FSK when the modulation order increases, the required bandwidth increases, which presents an obstacle to this modulation type.

Daskalakis *et al.* [22], designed and integrated an ultra-low-power sensor tag. The tag could read up to four sensors and modulate data using 4-Pulse Amplitude modulation (PAM) to increase the transmitted bit rate and send it to a low-cost Software Defined Radio (SDR) reader. The tag did not require batteries and was supplied with a small solar panel, consuming only 27 μ W.

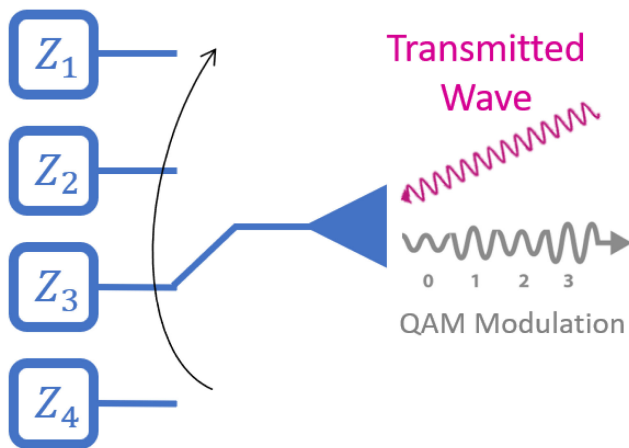

FIGURE 3. Quadrature amplitude modulation (QAM) modulation system.

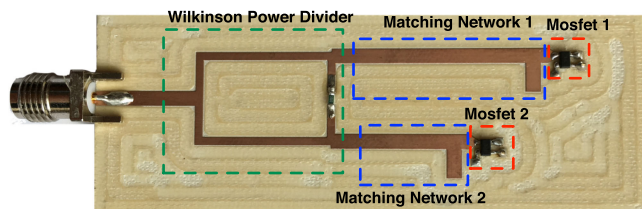

FIGURE 4. Photograph of the 16-QAM backscatter circuit. Original source: [23].

It is possible to combine some basic modulations to obtain more modulation types, like the QAM which combines amplitude and phase modulation. This technique uses this combination to change the antenna impedance, and as shown in Fig. 3, each impedance will correspond to a symbol used to transmit the digital message.

In [23], the authors presented a novel modulator that works with a Wilkinson power divider with a phase shift and two transistors working as switches to generate M-QAM, as can be seen in Fig. 4. This modulation technique permits high-bandwidth and low power wireless communications. The 16-QAM modulator demonstrated in [23] has an energy consumption as low as 6.7 pJ/bit for a bit rate of 120 Mb/s.

Thomas *et al.* [24] presents a 4-PSK/4-QAM system for backscatter communication, increasing the data rate and reducing the on-chip power consumption. The modulator is composed of a semi-passive tag operating in 850–950 MHz with a bit rate of 400 kbits⁻¹.

C. TOWARDS GBPS TRANSMISSION OR ULTRA HIGH BIT RATE BACKSCATTER MODULATORS

Typically backscatter communication systems have been associated with low bit rate transmission rates such as for example is the case of commercial RFID systems that operate with bit rates in the order of 100 Kbps [32]. The low bit rate results in very low power consumption (current RFID tags can have sensitivities of less than -20 dBm) [33], which is particularly

suitable for sensing applications that involve a simple identification or environmental parameter sensing which requires random or periodic measurements with considerable periods such as days, weeks or months. The ability for low power is further enhanced by passive sensing architectures [34], [35] and [36].

More recently however, backscatter modulators capable of very high bit rates and complex modulation formats have been demonstrated, as can be seen in Table I.

These high modulation rates are obtained while maintaining a very low power front-end comprising one or two elementary nonlinear devices, compared to traditional transceiver architectures that require amplifier and oscillator stages that are significantly more power hungry.

Furthermore, a millimeter wave backscatter front-end supporting Gbps modulation rates has been demonstrated [37]. The front-end comprised an off-the-shelf Avago VMMK-1225 pHEMT transistor and a five element microstrip series fed circularly polarized antenna array, inkjet printed on a flexible liquid crystal polymer (LCP) substrate. A BPSK signal of 4 Gbps was successfully transmitted by applying the modulation signal on the transistor gate. In addition to demonstrating for the first time a Gbps millimeter wave backscatter system, one has to highlight the use of an additive manufacturing technique such as inkjet printing to fabricate the front-end, which presents a step towards low cost, large volume fabrication of millimeter wave systems and furthermore, the use of a flexible substrate which itself is a step towards enabling the implementation of conformal front-ends that can be integrated in wearables. Due to the backscatter architecture, the front-end presents an ultra low 0.15 pJ/bit power consumption, which is significantly lower than the typical consumption associated with millimeter wave front-ends. The fabricated tag and the test set-up is shown in Fig. 5.

IV. AMBIENT BACKSCATTER

With the evolution of telecommunications and the emergence of new communication types, the number of transmitters and receivers has increased exponentially rising the economic and environmental costs. Research has turned to reuse existing Radio Frequency (RF) signals trying to reduce costs and Electromagnetic (EM) pollution.

A. SPECTRUM OPPORTUNITIES

A backscatter tag can reflect and modulate RF signals from TV, Cell or Frequency Modulated (FM) towers, Wi-Fi (Wi-Fi), ZigBee, or Lora access points, creating the concept of Ambient Backscatter.

The work in [38], analyses the frequency spectrum in Aveiro, Portugal. In Fig. 6, it is possible to see pikes of power in several frequencies, corresponding to different devices. Digital Television (D-TV) is the Portuguese Digital Television broadcast and Multichannel Multipoint Distribution Service (MMDS) is mainly used for satellite television broadcast as an alternative to cable television. Global System for Mobile Communications (GSM), Digital Cellular Service

TABLE 1. Performance Summary and Comparison Between High Order Backscatter Modulators

Reference	[25]	[26]	[27]	[28]	[29]	[30]	[31]
Technology	Integrated circuit	Discrete components	Discrete components	Discrete components	Integrated circuit	Discrete components	Integrated circuit
Frequency	5.8 GHz	900 MHz	900 MHz	868 MHz	2.9 GHz	2.45 GHz	10 GHz to 11.1 GHz
Modulation	32-QAM	4-QAM	16-QAM	QAM	BPSK	16-QAM	BPSK
Data rate	2.5 Mb/s	400 kb/s	96 Mb/s	-	330 Mb/s	960 Mb/s	10 Mb/s
Power consumption	113 uW	115 nW	1.4 mW	80 mW	0.12 mW	59 uW	-
Energy p/bit	45.2 pJ/bit	0.29 pJ/bit	15.5 pJ/bit	-	0.36 pJ/bit	61.5 fJ/bit	-

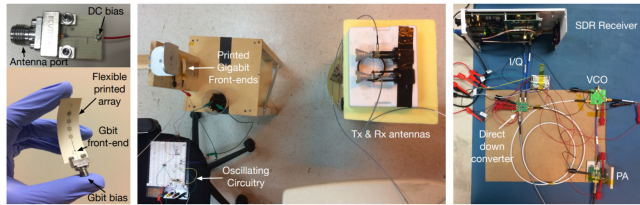

FIGURE 5. Left: mm-wave backscatter front-end for characterization and flexible printed $\times 1$ circularly-polarized antenna array with Gbit front-end. Center: Wireless measurement setup. Right: Tx and Rx chains with Software Defined Radio. Original source: [37].

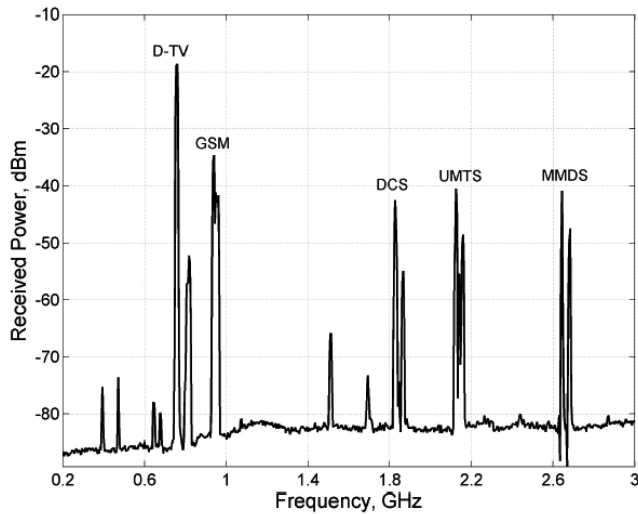

FIGURE 6. Power spectrum of Aveiro. Original source: [38].

(DCS) and Universal Mobile Telecommunications System (UMTS) are mobile communications systems. GSM is also known as GSM-900 and DCS as GSM-1800.

Although not referenced in Fig. 6, signals such as FM, Wi-Fi, BLE, or 5G can also be used as sources for ambient backscatter communications. The power values related to these bands are not present in any of the works, except the frequency band related to FM signals that has values approximately between -55 dBm and -88 dBm for the city of Aveiro

The spectrum opportunities highlighted are:

- D-TV - 750 to 758 MHz;
- GSM - 925 to 960 MHz;
- DCS - 1805 to 1880 MHz;

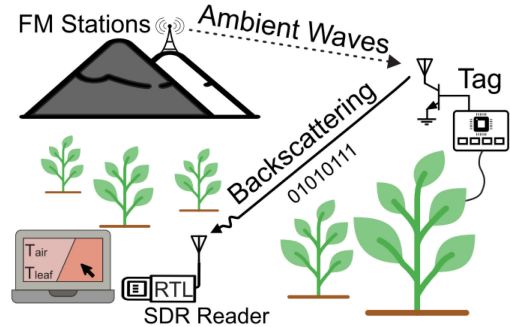

FIGURE 7. FM Backscatter system overview. Original source: [39].

- UMTS - 2110 to 2170 MHz;
- MMDS - 2500 to 2690 MHz;

B. AMBIENT BACKSCATTER SYSTEM

The FM signal is a popular source in this type of system. In work [39], the authors used this type of wave to transmits the sensor data present in agricultural fields. The tag consists of an ultra-low-power PIC16 Microcontroller Unit (MCU) connected to an RF front-end, as depicted in Fig. 7. In the experiment the FM tower is located far away from the backscatter tags, saying 34.5 km. In this bistatic arrangement, the communication range between the tag and the receiver reaches around 5 m. This backscatter link can support a data rate of 2.5 kbit s^{-1} with a $36.9 \mu\text{J}$ energy consumption per packet.

Still, with FM radio signals as the source, Wang [40], showed that it is possible to transform backscatter tags in FM radio sources and regular FM receivers, like smartphones or autoradios, into backscatters demoduladores. The prototype designed and executed achieved a data rate of 3.5 kbit s^{-1} and ranges of 1 to 20 m while consuming just over $11.07 \mu\text{W}$ of power. To improve the prototype’s work and usefulness, antennas were introduced in posters or banners to communicate advertisements to cars in the vicinity.

Kellogg in 2014 [41] used Wi-Fi Access Point (AP)s as a signal source for backscatter communication. They set the RF-powered devices to be wireless sensor nodes embedded in everyday objects. The signal is reflected by an analog circuit connected to an antenna and modulated to be received by a commercial reader. It is a standard mobile phone, as shown in

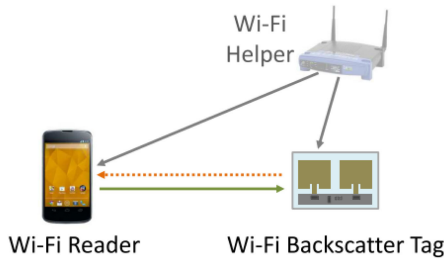

FIGURE 8. Wi-Fi backscatter overview. Original source: [41].

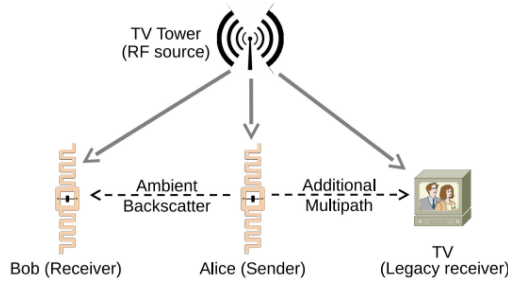

FIGURE 9. TV signal backscatter overview. Original source: [43].

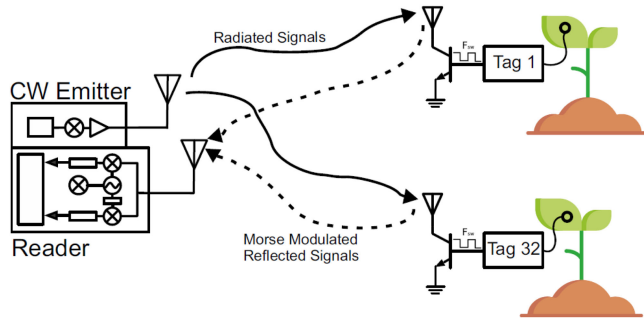

FIGURE 10. Monostatic backscatter communication setup. Plant sensing is achieved by the tags and the information is sent back to a low-cost reader. Information is modulated using Morse coding on a 868 MHz radiated carrier. Original source: [44].

Fig. 8. The experiments achieved communication rates of up to 1 kbits^{-1} and ranges of up to 2.1 m.

Another work that uses Wi-Fi signal as the main source is BackFi [42]. It uses Wi-Fi AP to transmit data from IoT sensors. Modulating Wi-Fi signals was possible to achieve communication rates of up to 5 Mbits^{-1} at a range of 1 m and 1 Mbits^{-1} at a range of 5 m.

TV Towers can be used as backscatter communication carrier sources and work in the same way as a dedicated signal source. Liu [43] used existing TV and cellular transmissions to eliminate the need for wires and batteries, thus facilitating universal communication where devices can communicate at unprecedented scales and in previously inaccessible locations, as shown in Fig. 9. The backscatter tag uses a 258 mm dipole antenna, optimized for a 50 MHz subset of UHF TV band and connected to it, had RF switches optimal for the ambient signals' operational frequencies. This scheme achieves an

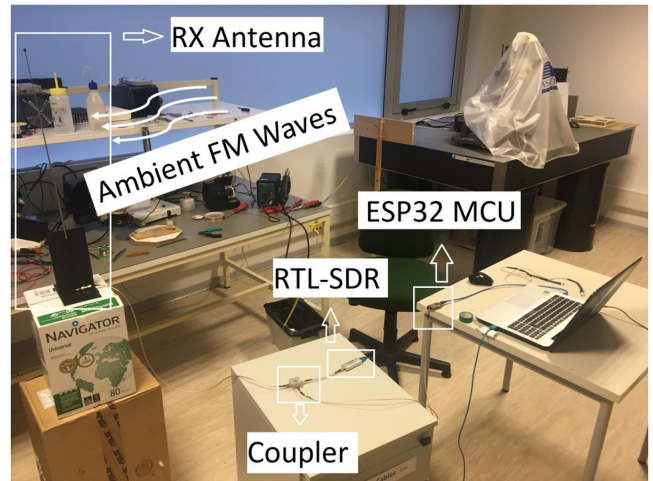

FIGURE 11. Real ambient FM measurements setup, Original source: [47].

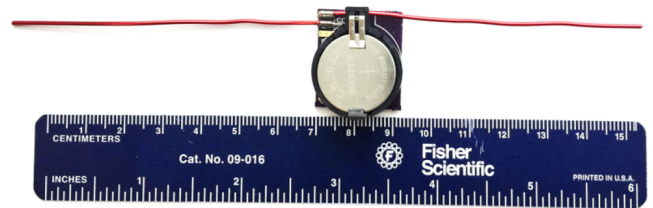

FIGURE 12. Photo of digital backscatter prototype. Original source: [48].

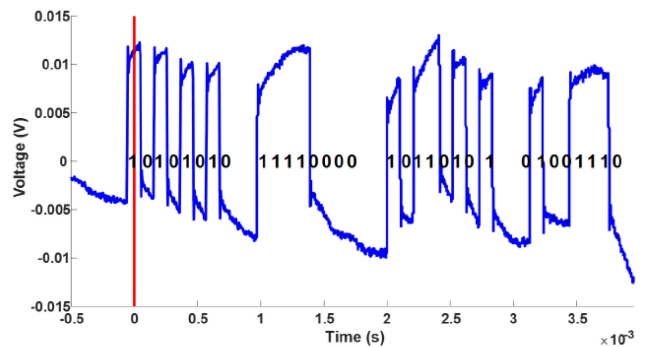

FIGURE 13. Measured waveform of baseband data at a distance of 3 m of the tag. Original source: [48].

information rate of 1 kbits^{-1} over distances of 1.5 m while operating outdoors and 1 m indoors.

V. ANALOG BACKSCATTER

Nowadays, the high-cost and the high-power requirements of the Wireless Sensor Networks (WSN) hardware prevent its limited usage in many applications like in the industry or in agricultural sector. For example in agriculture applications, the deployment of these systems, therefore, relies on reducing the cost to an affordable amount. Analog Backscatter radio communication combined with the use of energy-assisted (or not) sensor tags is a method that addresses the aforementioned

constraints [44]. This leads to the concept of precision agriculture or smart farm that enables farmers to optimize the usage of resources, e.g. water [45].

Here a low-cost and low-power wireless sensor tag was developed which is able to sense the temperature difference between the leaf and the ambient air. This difference is known to be relevant to the water stress of the plant, thus, the tag acts as an indicator to guide or control the local irrigation system [46].

The tag implemented here includes a microcontroller (MCU) for all base band processing and also the control purpose. An external timer was added for time synchronization of the data modulation. In the experiment, the information captured by the sensors is first converted to digital signals through an ADC, and then voltage pulses are generated to drive an RF switch. The backscatter modulation scheme was set to the Morse code that is applied on the carrier signal of 868 MHz. Here the Morse code uses On-Off-Keying (OOK) modulation which translates to presence and absence of the backscattered signals. In the experiment the reader was implemented using a low-cost SDR which samples the captured signals for further baseband processing.

A prototype was implemented which was powered by a small solar panel producing energy of around 20 μ W. The over the air experiment was conducted to demonstrate the successful backscatter link established up to a distance of 2 meters.

VI. ALL-DIGITAL BACKSCATTER SYSTEM

All the works described above were based on semiconductors and matching networks to obtain the desired output impedances.

To minimize the costs of producing Backscatter tags and leveraging the MCUs capability to receive and store data from the sensor networks, the work presented by Torres *et al.* [47], shows a fully digital ambient backscatter system which operates with ambient FM sources, with a power of approximately 70 dBm. In this system the backscatter module uses an ESP32 MCU and a telescopic monopole as an antenna. The variation of a digital IO pin causes an impedance variation in the connected antenna reflecting the incoming FM waves with an ASK modulation and can be demodulated by a low-cost RTL-SDR USB dongle, as shown in Fig. 11.

The solution presented enable a large number of applications that can benefit from the different technologies that can be used with the commercial modules tested, such as Wi-Fi, Bluetooth and ambient backscatter communication.

In [48], the author produces a digital backscatter tag connecting a dipole to a digital IO pin of the PIC16 MCU, presented a digital backscatter tag.

The BPSK modulation was created by varying the state of the digital pin. The different states of the digital pin, input, and output introduce a different impedance in the dipole, causing a total reflection or absorption of the transmitted wave generated by a Vector Signal Generator. As shown in Fig. 13, the

wave, after reflection by the tag, creates a coherent set of bits that a commercial reader can demodulate.

VII. ULTRA-LONG RANGE BACKSCATTERING COMMUNICATION

A. MM-WAVE BACKSCATTERING-ENABLED (MMID) COMMUNICATIONS AND LOCALIZATION

1) BACKSCATTER ARCHITECTURES, UNIQUELY, ENABLE LONGER RANGES AT HIGHER FREQUENCIES

The expansion of the concept of RFIDs to mmIDs has first been initiated in [49], where mm-wave RFIDs were introduced for the first time as mmIDs, demonstrating the potential for short-range, low-power, and high data-rate communications. The promised ultra-high Gbps modulation rate was realized in the mm-wave backscattering system presented in Section III. In this section, we target the capability of mmIDs in achieving ultra-long range communications using unique combined antenna and beamforming architectures. The concept of “path loss” is generally invoked to evaluate the dependency of link budgets as a function of frequency. Due to its $\propto 1/f^2$ relationship, it is almost uniformly concluded that link budgets suffer from increases in operating frequencies. This path loss is inflicted twice upon monostatic backscatter links—back and forth—and it may, consequently, seem ridiculous to expect acceptable or even enhanced link budgets from backscatter systems operating in higher-frequency bands. This reasoning is, nevertheless, fallacious; twice. As described in excruciating details in [50], losses due to propagation (in approximately lossless media) are solely the cause of a dilution of power, which is not a function of frequency. As a consequence, two systems—one operating at frequency f_1 , and the other at frequency f_2 , where $f_1 < f_2$ —using identical emitting equivalent isotropically radiated powers (EIRPs) and receiving antenna effective apertures witness exactly the same link from the reader to the tag. However, due to the enhanced gain at frequency f_2 , the higher-frequency-operating system benefits from a link budget enhanced by $(\frac{f_2}{f_1})^2$ for the backscattered signal on the way back to the reader: the energy of the backscattered signal is focalized in the direction of the reader (hopefully), where it needs to go. Concretely, everything else being equal, this means that a backscatter system operating in the 24.125 GHz ISM band instead of its equally-sized 900 MHz UHF-operating counterpart is endowed with a 28.5 dB boost in SNR or, equivalently, a 5.2 \times increase in reading range. Despite this theoretical benefit, one may object that—due to the necessity for most tags to be approximately orientation-agnostic—relying upon a narrow high-gain beam may be impractical. However, the use of backscattering approaches uniquely enables the employment of structures whose very typologies passively re-emit the wave (with high gain) in the direction of the reader: retrodirective front-ends. While contingent upon the vicissitude and idiosyncrasies of antenna and (more generally) front-end design, it will be shown in the next subsections how the implementation of this theoretical realization has already been applied to demonstrate



(a)



(b)

FIGURE 14. (a) Picture of the fully-inkjet-printed Van-Atta reflectarray chipless mmID [51], (b) Measurement configuration for a 30 m-range detection of the chipless tag. Original source: [50].

unmatched backscatter performance, using two unique structures: the Van-Atta reflect-array and the Rotman lens.

2) VAN-ATTA CROSS-POLARIZING RETRODIRECTIONAL ARCHITECTURE FOR ULTRA-LONG-RANGE CHIPLESS AND SEMI-PASSIVE MMIDS

The first implementation of this principle was in the form of an ultra-thin and flexible fully-inkjet printed cross-polarizing Van-Atta-based chipless RFID (shown in Fig. 14(a)), reported in [51] and matured in [50]. The tag consists of five dual-polarized linear rectangular-antenna patch arrays connected symmetrically with reference to the axis of symmetry in order to form a Van-Atta retrodirective structure. By connecting horizontally-polarized antenna ports to their vertically polarized complements, the 28 GHz structure achieved a high cross-polarized monostatic Radar Cross-Section (RCS) of up to -27 dBsm, varying only by 10 dB over an angular coverage of 120° . Thanks to the high signal level provided by the retrodirective effect and to the cross-polarization of its reflected signal—allowing its polarimetric isolation from the

nearby interfering clutter—the tag was able to be detected at an unprecedented range of 30 m in realistic conditions, as shown in Fig. 14(b). This achievement outperformed the state of the art in chipless RFID reading range by more than an order of magnitude. Furthermore, the large bandwidths available and the use of a novel frequency/delay 2D spectrogram processing scheme allowed for the precise localization and the resolution of several tags in close proximity, thereby demonstrating the capability of the approach to provide a foundation for the deployment of ultra-dense chipless RFID constellations.

The aforementioned chipless structure was modified in [52] to enable it with backscatter communication capabilities. To the lines connecting the linear antenna arrays together were added low-cost single-GaAs-FET switches, enabling OOK modulation of the backscattered signal. The baseband of the structure, shown in Fig. 15(a), was constituted of a single low-power LMC555 timer, consuming approximately $216 \mu\text{W}$, supplied by a flexible solar cell. The entire 28 GHz structure was printed on a thin flexible Rogers LCP substrate, along with a fully-inkjet-printed PABS-functionalized single-wall-carbon-nanotubes ammonia sensor. The power-autonomous structure thereby allowed the real-time measurement of airborne ammonia levels in its vicinity at an unprecedented monostatic range in excess of 80 m, as shown in Fig. 15(b). This effort not only demonstrated that the use of mm-waves could open the door for the advent of ultra-thin energy autonomous mmID backscatter tags with unparalleled reading range, but also provided a preview of, arguably, the most impactful capability of such systems. Indeed, due to the relatively large bandwidths available in mm-wave bands, and to the commoditization of low-cost mm-wave radar modules, these mmID tags offer the opportunity to enhance the state of the art of real-time localization technologies with ultra-low-cost battery-less tags detectable in both radial and angular dimensions at ranges exceeding 100 m. A preview of such advances is provided in [53], where miniaturized 24 GHz tags were localized in such a manner with better than 20 cm of accuracy.

3) ROTMAN LENS RETRODIRECTIONAL ARCHITECTURE FOR FULLY-PASSIVE MMID

An alternative approach to the Van Atta architecture presented here is the use of passive Beamforming Networks (BFNs)-based RFID tags, that have the ability to focus the reflected signal in a specific direction. The Rotman lens is a unique type of passive BFNs that combines all the power received on its antenna ports, on one side, and focuses it towards the beam port(s) associated with the direction of arrival of the signal. Depending on the intended use, rectifiers such as in [54], [55] can be placed at the beam ports to collect the RF power and convert it to DC, or switches such as in [56] can be connected to modulate the signal and reflect it back for communication purposes. Unlike the Van Atta structure that divides the

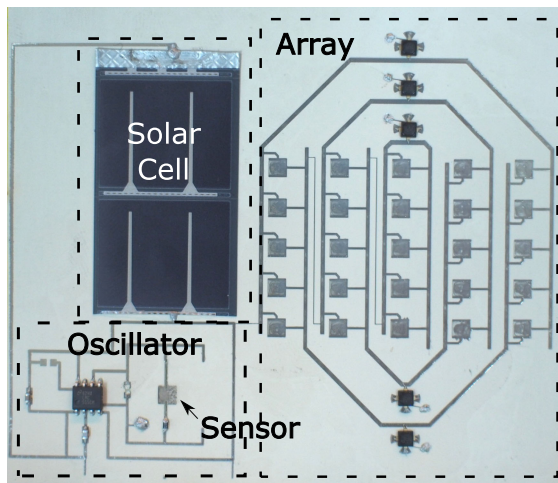

(a)

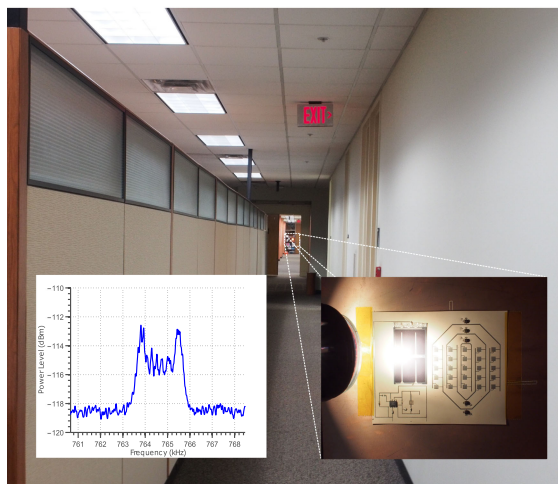

(b)

FIGURE 15. (a) Picture of the ammonia-sensing inkjet-printed Van-Atta reflectarray semi-passive mmID, (b) Measurement configuration for a 80 m-range detection of the semi-passive tag, Original source: [52].

power among its lines and is, therefore, ill-suited for optimal harvesting performance, the Rotman lens—offering RF combination—can enable the operation of fully-passive RFID tags at longer turn-on ranges, if rectifiers are connected to the beam ports to power the tag. Moreover, the Rotman lens can be modulated by simply changing the load on all beam ports and is compatible with all impedance-modulation techniques applied to traditional lower frequency RFIDs. The Van Atta on the other hand, is limited to amplitude modulation schemes unless made hybrid and more complex [57], [58].

In [56], a Rotman-based semi-passive RFID backscattering tag was presented, demonstrating simultaneous high gain and wide angular coverage, while only consuming $2.64 \mu\text{W}$, fully provided by the attached flexible solar cell, as shown in Fig. 16(a). The Rotman lens is surrounded by eight antenna ports from one side, where serially-fed patch antenna arrays

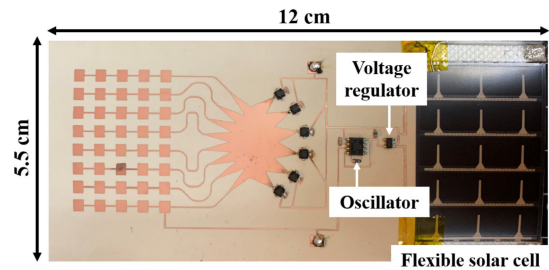

(a)

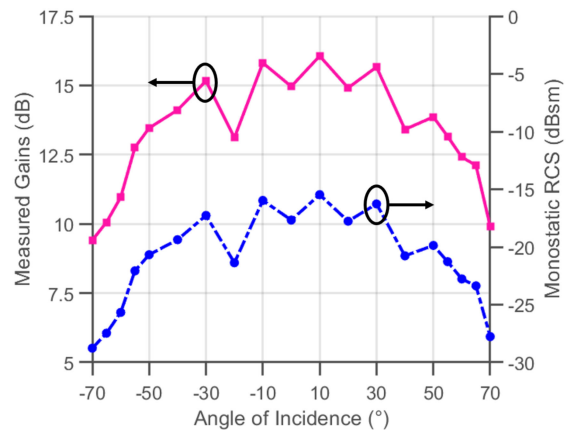

(b)

FIGURE 16. (a) Picture of the fully-flexible power-autonomous Rotman-based semi-passive RFID tag proof-of-concept prototype, (b) Plot of the measured Monostatic differential RCS as well as the extracted gain of the structure, Original source: [56].

were connected, and six beam ports with mm-wave switches attached to them. Added to the structure are the low-power oscillator (CSS555) and a voltage regulator. The monostatic differential RCS and the gain of the Rotman lens structure were thoroughly studied in both planar and bent conditions [56]. The structure reveals a peak gain of 16.5 dB and a large angular coverage of 110° , properties that prove its successful implementation as a retrodirective array. Fig. 16(b) also shows that this architecture has a high and isotropic differential RCS with a measured peak of -15.4 dBsm and a variation of less than 8 dB for an interrogation angle ranging from -60° to 60° . The long-range communication capabilities of this structure were also tested in an indoor hallway for ranges up to a distance of 64 m. With the measured signal-to-noise ratio in this conducted experiment (determined by the noise floor, modulation offset and sampling rate), the maximum indoor range that could be achieved is 179 m with 48 dBm EIRP. By minimizing the phase noise coupling between the TX and RX antennas on the reader side—technique used with Van Atta reflectarray through polarization isolation—the noise floor could be greatly improved and the expected outdoor range is calculated to be 1.8 km with the allowable 75 dBm at 5G frequencies.

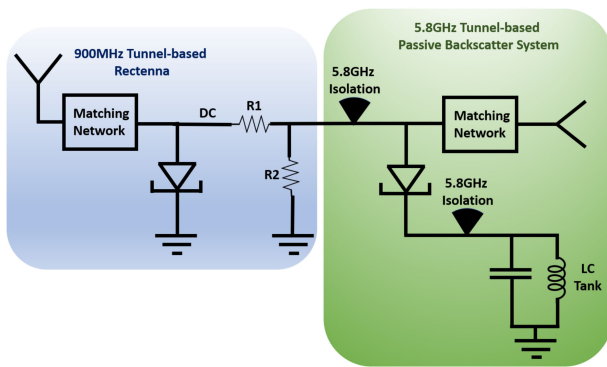

FIGURE 17. Schematic of the fully-tunnel-diodes-based passive backscatter tag, Original source: [61].

B. TUNNEL DIODE-BASED BACKSCATTERING COMMUNICATION

Extending backscatter communication ranges can be realized using high gain retrodirective arrays and BFNs-based RFID architectures as presented in the previous section. Another mean to achieve this goal is with the implementation of active devices known as reflection amplifiers. Two-terminal devices, such as tunnel diodes, are preferred over NPN transistors, since they enable at least one order of magnitude lower power consumption. For example, in [59], the BFT25A NPN transistor was used at 900 MHz as a reflection amplifier for range extension, realizing a gain of 29 dB at an input power of -50 dBm. The power consumption of the system was calculated to be $664 \mu\text{W}$, which is relatively high. Alternatively, tunnel diodes, based on quantum mechanical effect, have been used as reflection amplifiers in [60], demonstrating extended ranges with a measured power consumption of $45 \mu\text{W}$ and a biasing voltage of 90 mV. However, the reported voltage and power requirements in the aforementioned work includes solely that of the front-end circuitry, a negligible portion of the overall power consumption of those systems, whose main power draws are located in their baseband circuitry. The use of external oscillators, such as the CSS555 micro-power timer (biased with a voltage of 1.2 V), sets a high voltage requirement that is difficult to reach with ambient energy harvesters. A solution, enabling simultaneous long communication ranges and low voltage and power requirements, was presented in [61], based on the use of tunnel diodes as a reflection amplifier, an oscillator, and a rectifier. The reported system is shown in Fig. 17, where two tunnel diodes were used: one as a combined oscillator/reflection amplifier and the second as a rectifier, to achieve a power-autonomous, high-gain, low-voltage and low-power 5.8 GHz RFID backscattering tag.

Connected to an LC tank and biased at a specific point driving its negative resistance region, the tunnel diode can operate as an oscillator. Since they are not limited by transit-time effects, tunnel diodes can enable oscillations up to GHz frequencies while consuming a fraction of the voltage required by currently available solutions. The tunnel diode used in this work was the MBD2057-E28X from Aeroflex, that displays a

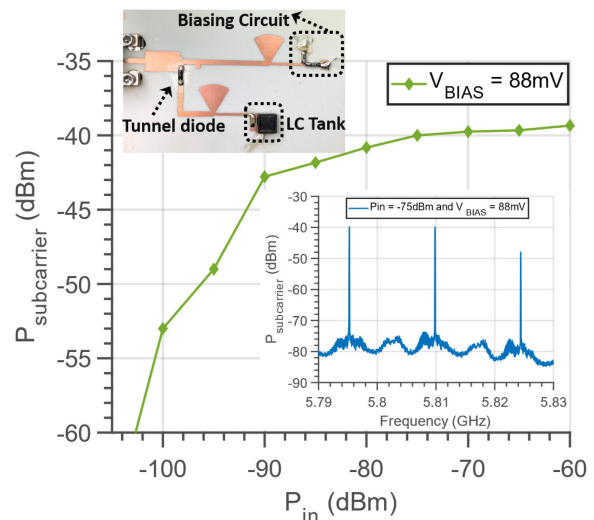

FIGURE 18. Photo of the combined oscillator/reflection amplifier system with the measured sub-carrier powers over a range of RF input powers and (inset) plot of the measured spectrum of the modulated and amplified RF signal for $P_{in} = -75$ dBm, Original source: [61].

negative resistance when biased between 70 mV and 180 mV. However, it was observed that the tunnel diode-based oscillator is very sensitive to biasing voltage, with a good operation limited to a biasing range between 70 mV and 90 mV. The modulation frequency was chosen to be 7 MHz, determined by the dimensions of the LC tank. Its power consumption was measured to be $19 \mu\text{W}$.

Added to its oscillation capability, the tunnel diode, in the negative region, displays reflection coefficients Γ and modulation factor greater than unity, resulting in amplified backscattered signals. The reflection amplifier was first characterized without the LC tank to assess the returned gains with respect to varying biasing voltages and input powers. The optimal biasing voltage was found to be 120 mV, where the reflection amplifier displays a gain of 51 dB for an input power of -110 dBm. At this bias point, the reflection amplifier consumes only $18 \mu\text{W}$. After demonstrating the ability of the tunnel diode to achieve both a modulation and an amplified signal in two separate circuits, the two functionalities were merged in one system using a single tunnel diode. Since the reflection amplifier is less sensitive to the biasing voltage compared to the oscillator, 88 mV was chosen as a biasing point.

The successful operation of the combined oscillation/amplification functionalities of one tunnel diode was validated, as shown in Fig. 18, where the received powers of the subcarrier were plotted for an input power ranging from -105 dBm to -60 dBm. The system is capable of achieving gains ranging from 21 dB to 48 dB with a modulation frequency of 7 MHz, while merely consuming 88 mV and $20 \mu\text{W}$. This system was then powered using a tunnel diode-based rectifier designed at 900 MHz, resulting in the first fully-tunnel-diodes-based power autonomous, long-range backscattering RFID tag.

VIII. READING BACKSCATTER SIGNALS WITH LEGACY DEVICES

In most reported backscatter systems, a dedicated reader, commonly implemented using software defined radios (SDRs), is required. This inevitably increases the system costs with regard to both development and deployment. In order to eliminate dedicated readers, instead resource to other widely available wireless infrastructure/devices like mobile phones, Bluetooth devices, cellular/IoT base stations, etc., the backscatter signals that resemble the signal formats in the air interface of the targeted systems have to be synthesized.

This effort was first attempted in 2014 [41] where the amplitude-domain backscatter modulation was applied on to the incoming WiFi signals on a per-packet basis. Though existing WiFi readers can be reused for backscatter demodulation, it requires the access to vendor-specific Channel State Information (CSI) and Received Signal Strength Indicator (RSSI) information from the WiFi chipset, which unfortunately are commonly inaccessible. The same concept was later exploited to endow various 3D-printed devices, from push buttons to flowmeters, with the ability to be WiFi connected [62]. Distinct to this non-standard protocol, the WiFi IEEE 802.11b compatible backscatter signals were synthesized in [63]. Here the required phase shifts through backscattering modulation, e.g. $\pi/2$ for DBPSK and $n\pi/4$ ($n = 1, 2, 3$) for DQPSK, were achieved by delaying square waves generated by the digital switches controlling backscatter antenna impedance in time domain. This makes all legacy IEEE 802.11b devices as backscatter readers without any modifications on hardware and firmware. The unwanted harmonic spurious created due to square-wave and sine-wave approximation can be reduced or even eliminated using the techniques presented in [64]. Recently, with the ability of controlling both magnitude and phase of each backscatter samples, thanks to the IQ-backscatter modulators [65], the multicarrier OFDM-based IEEE 802.11 g signals have been successfully obtained in [66].

Other efforts have been focused on Bluetooth and LoRa compatible backscatter signals. In [67], [68], the Gaussian-shaped 2FSK modulated signals, located in three Bluetooth advertising channels, were backscattered upon an incoming CW tone. It achieves energy efficiency of 28.4 pJ/bit, two orders of magnitude lower than that in the conventional Bluetooth transmitters. When an ambient Chirp Spread Spectrum (CSS) modulated LoRa signal is available, the 2FSK backscatter modulator was found useful to create a new LoRa signal in an adjacent frequency channel [69]. Other approaches to synthesizing LoRa-compatible signals from an incoming sine tone were presented in [70] and [71]. Here either the tag antenna impedance switching frequency, altered by a voltage controlled oscillator (VCO), or the phase increments between consecutively switched tag load impedance, altered through transistor voltages in IQ backscatter modulators, was utilized to continuously shift the frequency of backscatter signals. This CSS modulated backscatter signal enjoys the superior demodulation sensitivity, extending the backscatter

communication range to hundreds of, or even thousands of, meters.

On the backscatter tag end, the ambient OFDM modulated signals are non-constant and unpredictable in both time and frequency domains in each transmission frame, limiting the symbol rates of ambient backscatter modulations to be higher than the OFDM frame rate. One possible solution is to co-design the OFDM signal waveforms, namely synthesizing OFDM signals with a fixed bit sequence. This, however, requires the backscatter communication system to be able to access the OFDM core networks. On the receiver end, the challenge is the detection of the existence of the extra added ambient backscatter signals which in generally is extremely weak compared with ambient OFDM signals. The synchronization (in time, frequency, and phase) approaches need to be further developed for various ambient backscatter communications. All these may require the firmware modification so as to allow smartphone applications getting access of the necessary raw signal characteristics.

IX. DISCUSSION

This section provides a discussion of the topics previously presented. In addition, several of the limitations, potentials, and some applications is discussed. Backscatter is a new paradigm for IoT and sensor devices that has a battery as its main limitation. Nevertheless, most of these sensors also require very high bit rates, which creates a challenging problem for engineers. Some of the proposals presented in this paper combine WPT with backscatter transceivers, this improves the first problem, which is energy needs for IoT sensors, WPT is an area of high interest in energy availability for IoT. Which it is usually the limiting factor in coverage distance between a base station and a sensor. So, WPT was presented as a way to maintain a continuous flow of energy for these devices.

Regarding the high bit rate challenge, this paper also presents some initiatives to increase the data rate. These include the use of higher order modulation backscatter solutions and mm-wave backscatter devices with wideband scenarios. The paper gives some insights into circuit approaches to maximize bandwidth availability. Another limiting factor is the coverage range of these IoT sensors; this is also addressed by looking at mm-wave options based on purposely conceived circuits for passive Beamforming Networks.

In order to reduce even more the energy footprint of these systems, Ambient Backscatter is a technology that reuses signals already existing in our everyday environment to reduce the need for dedicated transmitters. Nevertheless, the sensitivity of the receivers is low, which makes the communication range between the Backscatter tag and the receiver even lower, and has lower data rates than other technologies. However, Ambient Backscatter systems can be beneficial from two perspectives: First, they can reduce the need for energy for a communication system to extremely low powers or even passive. Second, they increase the capacity and reliability of large wireless IoT networks, as presented in [72].

In order to merge backscatter solutions with commercial devices, this paper also addresses All-Digital Backscatter solutions, where integrated systems can be connected directly to an antenna, reducing the cost in the production of large wireless sensor networks and the need for additional components. Connecting an antenna to an MCU can allow the transmission of information by backscatter from any connected sensor.

In summary, feature IoT sensors will profit significantly by using the technologies presented in this paper: WPT combination with backscatter, higher order modulation, specially design passive Beamforming Networks and ambient reuse of the spectra.

X. CONCLUSION

In this paper a summary of the more recent advancements in physical layer and circuit manufacturing for backscatter approaches were presented, it is expected that this paper can be a source of motivation and initial background for the development of backscatter approaches in IoT solutions.

REFERENCES

- [1] P. Nikitin, "Leon Theremin (Lev Termen)," *IEEE Antennas Propag. Mag.*, vol. 54, no. 5, pp. 252–257, Oct. 2012.
- [2] A. G. Bell, "The photophone," *Science (80-.)*, vol. 1, no. 11, pp. 130–134, 1880.
- [3] H. Stockman, "Communication by means of reflected power," *Proc. IRE*, vol. 36, no. 10, pp. 1196–1204, Oct. 1948.
- [4] D. B. Harris, "Radio transmission systems with modulatable passive responder," 1960.
- [5] K. Finkenzeller, *RFID Handbook*. Chichester, U.K.: Wiley, Mar. 2003.
- [6] J. R. Smith, A. P. Sample, P. S. Powledge, S. Roy, and A. Mamishev, "A wirelessly powered platform for sensing and computation," in *Proc. 8th Int. Conf. Ubiquitous Comput.*, 2006, vol. 4206, pp. 495–506.
- [7] L. Roselli, *RFID Green Systems*. Cambridge, U.K.: Cambridge Univ. Press, 2014.
- [8] P. H. Siegel, "Microwaves are everywhere: FID—Do you know where your pet is?," *IEEE J. Microwaves*, vol. 1, no. 3, pp. 679–688, Jul. 2021.
- [9] P. Mezzanotte, V. Palazzi, F. Alimenti, and L. Roselli, "Innovative rfid sensors for Internet of Things applications," *IEEE J. Microwaves*, vol. 1, no. 1, pp. 55–65, Jan. 2021.
- [10] A. P. Sample, J. Braun, A. Parks, and J. R. Smith, "Photovoltaic enhanced UHF RFID tag antennas for dual purpose energy harvesting," in *Proc. IEEE Int. Conf. RFID*, 2011, pp. 146–153.
- [11] S. Roundy, P. K. Wright, and J. Rabaey, "A study of low level vibrations as a power source for wireless sensor nodes," *Comput. Commun.*, vol. 26, no. 11, pp. 1131–1144, 2003.
- [12] A. Sample and J. R. Smith, "Experimental results with two wireless power transfer systems," in *Proc. IEEE Radio Wireless Symp.*, Jan. 2009, pp. 16–18.
- [13] F. Pereira, R. Correia, and N. Carvalho, "Passive sensors for long duration Internet of Things networks," *Sensors*, vol. 17, no. 10, p. 2268, Oct. 2017. [Online]. Available: <https://www.mdpi.com/1424-8220/17/10/2268>
- [14] J. Kracek, M. Svanda, M. Mazanek, and J. Machac, "Implantable semi-active UHF RFID tag with inductive wireless power transfer," *IEEE Antennas Wireless Propag. Lett.*, vol. 15, pp. 1657–1660, 2016.
- [15] F. J. Velez, N. Barroca, L. M. Borges, R. Chávez-Santiago, and I. Balasingham, "Radio-frequency energy harvesting for wearable sensors," *Healthcare Technol. Lett.*, vol. 2, no. 1, pp. 22–27, Feb. 2015.
- [16] V. Kuhn, F. Seguin, C. Lahuec, and C. Person, "A multi-tone RF energy harvester in body sensor area network context," in *Proc. IEEE Loughborough Antennas Propag. Conf.*, Nov. 2013, pp. 238–241.
- [17] D. J. Yeager, J. Holleman, R. Prasad, J. R. Smith, and B. P. Otis, "NeuralWISP: A wirelessly powered neural interface with 1-m range," *IEEE Trans. Biomed. Circuits Syst.*, vol. 3, no. 6, pp. 379–387, Dec. 2009.
- [18] A. Sample, D. Yeager, P. Powledge, A. Mamishev, and J. Smith, "Design of an RFID-based battery-free programmable sensing platform," *IEEE Trans. Instrum. Meas.*, vol. 57, no. 11, pp. 2608–2615, Nov. 2008.
- [19] R. Correia, N. B. Carvalho, and S. Kawasaki, "Continuously power delivering for passive backscatter wireless sensor networks," *IEEE Trans. Microw. Theory Techn.*, vol. 64, no. 11, pp. 3723–3731, Nov. 2016.
- [20] P. Jankowski-Mihulowicz and M. Węglarski, "A method for measuring the radiation pattern of UHF RFID transponders," *Metrol. Meas. Syst.*, vol. 23, pp. 163–172, May 2016.
- [21] W. Lerditsomboon and K. K. O., "Technique for integration of a wireless switch in a 2.4 GHz single chip radio," *IEEE J. Solid-State Circuits*, vol. 46, no. 2, pp. 368–377, Feb. 2011.
- [22] S. N. Daskalakis, R. Correia, G. Goussetis, M. M. Tentzeris, N. B. Carvalho, and A. Georgiadis, "Four-PAM modulation of ambient FM backscattering for spectrally efficient low-power applications," *IEEE Trans. Microw. Theory Techn.*, vol. 66, no. 12, pp. 5909–5921, Dec. 2018.
- [23] R. Correia and N. B. Carvalho, "Ultrafast backscatter modulator with low-power consumption and wireless power transmission capabilities," *IEEE Microw. Wireless Compon. Lett.*, vol. 27, no. 12, pp. 1152–1154, Dec. 2017.
- [24] S. J. Thomas, E. Wheeler, J. Teizer, and M. S. Reynolds, "Quadrature amplitude modulated backscatter in passive and semipassive UHF RFID systems," *IEEE Trans. Microw. Theory Techn.*, vol. 60, no. 4, pp. 1175–1182, Apr. 2012.
- [25] A. Shirane *et al.*, "13.8 A 5.8 GHz RF-powered transceiver with a 113 μ W 32-QAM transmitter employing the IF-based quadrature backscattering technique," in *IEEE Int. Solid-State Circuits Conf. Dig. Techn. Papers*, 2015, pp. 1–3.
- [26] S. J. Thomas, E. Wheeler, J. Teizer, and M. S. Reynolds, "Quadrature amplitude modulated backscatter in passive and semipassive UHF RFID systems," *IEEE Trans. Microw. Theory Techn.*, vol. 60, no. 4, pp. 1175–1182, Apr. 2012.
- [27] S. J. Thomas and M. S. Reynolds, "A 96 mbit/sec, 15.5 pJ/bit 16-QAM modulator for UHF backscatter communication," in *Proc. IEEE Int. Conf. RFID*, 2012, pp. 185–190.
- [28] M. Winkler, T. Faseth, H. Arthaber, and G. Magerl, "An UHF RFID tag emulator for precise emulation of the physical layer," in *Proc. Microw. Conf.*, 2010, pp. 273–276.
- [29] A. Tang, Y. Kim, and M.-C. F. Chang, "A 65 nm CMOS 330 Mb/s microwave backscatter link at 2.4 to 2.9 GHz with ambient blocker cancellation," *IEEE Microw. Wireless Compon. Lett.*, vol. 26, no. 1, pp. 61–63, Jan. 2016.
- [30] R. Correia and N. B. Carvalho, "Ultrafast backscatter modulator with low-power consumption and wireless power transmission capabilities," *IEEE Microw. Wireless Compon. Lett.*, vol. 27, no. 12, pp. 1152–1154, Dec. 2017.
- [31] X. Fu, A. Sharma, E. Kampianakis, A. Pedross-Engel, D. Arnitz, and M. S. Reynolds, "A low cost 10.0-11.1 GHz X-band microwave backscatter communication testbed with integrated planar wideband antennas," in *Proc. IEEE Int. Conf. RFID*, 2016, pp. 1–4.
- [32] K. Finkenzeller, *RFID Handbook: Fundamentals and Applications in Contactless Smart Cards, Radio Frequency Identification and Near-Field Communication*. Hoboken, NJ, USA: Wiley, 2010.
- [33] *Impinj Monza R6 Tag Datasheet*, 2020.
- [34] G. Marrocco, "Pervasive electromagnetics: Sensing paradigms by passive RFID technology," *IEEE Wireless Commun.*, vol. 17, no. 6, pp. 10–17, Dec. 2010.
- [35] J. Kimionis, A. Bletsas, and J. N. Sahalos, "Increased range bistatic scatter radio," *IEEE Trans. Commun.*, vol. 62, no. 3, pp. 1091–1104, Mar. 2014.
- [36] R. Bhattacharyya, C. Floerkemeier, and S. Sarma, "RFID tag antenna based sensing: Does your beverage glass need a refill?," in *Proc. IEEE Int. Conf. RFID*, 2010, pp. 126–133.
- [37] J. Kimionis, A. Georgiadis, and M. M. Tentzeris, "Millimeter-wave backscatter: A quantum leap for gigabit communication, RF sensing, and wearables," in *Proc. IEEE MTT-S Int. Microw. Symp.*, 2017, pp. 812–815.
- [38] T. Moura, "Sistema eficiente de recolha de energia resultante do espectro da D-TV," MSc thesis, Univ. Aveiro, 2015.
- [39] S. N. Daskalakis, J. Kimionis, A. Collado, G. Goussetis, M. M. Tentzeris, and A. Georgiadis, "Ambient backscatterers using FM broadcasting for low cost and low power wireless applications," *IEEE Trans. Microw. Theory Techn.*, vol. 65, no. 12, pp. 5251–5262, Dec. 2017.

- [40] A. Wang, V. Iyer, V. Talla, J. Smith, and S. Gollakota, "Fm backscatter: Enabling connected cities and smart fabrics," Feb. 2017.
- [41] B. Kellogg, A. Parks, S. Gollakota, J. Smith, and D. Wetherall, "Wi-fi backscatter: Internet connectivity for RF-powered devices," *Comput. Commun. Rev.*, vol. 44, pp. 1–12, 2014.
- [42] D. Bharadia, K. Joshi, M. Kotaru, and S. Katti, "Backfi: High throughput wifi backscatter," *ACM SIGCOMM Comput. Commun. Rev.*, vol. 45, pp. 283–296, 2015.
- [43] V. Liu, A. Parks, V. Talla, S. Gollakota, D. Wetherall, and J. R. Smith, "Ambient backscatter," *ACM SIGCOMM Comput. Commun. Rev.*, vol. 43, no. 4, pp. 39–50, Aug. 2013.
- [44] S. N. Daskalakis, G. Goussetis, S. D. Assimonis, M. M. Tentzeris, and A. Georgiadis, "A UW backscatter-morse-leaf sensor for low-power agricultural wireless sensor networks," *IEEE Sensors J.*, vol. 18, no. 19, pp. 7889–7898, Oct. 2018.
- [45] S. N. Daskalakis, S. D. Assimonis, G. Goussetis, M. M. Tentzeris, and A. Georgiadis, "The future of backscatter in precision agriculture," in *Proc. IEEE Int. Symp. Antennas Propag. USNC-URSI Radio Sci. Meeting*, 2019, pp. 647–648.
- [46] V. Palazzari et al., "Leaf compatible "eco-friendly" temperature sensor clip for high density monitoring wireless networks," in *Proc. IEEE 15th Mediterranean Microw. Symp.*, 2015, pp. 1–4.
- [47] R. Torres, R. Correia, and N. B. Carvalho, "All digital ambient backscatter," in *Proc. IEEE Wireless Power Transfer Conf.*, 2020, pp. 15–19.
- [48] A. Dadkhah, J. Rosenthal, and M. S. Reynolds, "ZeroScatter: Zero-added-component backscatter communication using existing digital I/O pins," in *Proc. IEEE Top. Conf. Wireless Sensors Sens. Netw.*, 2019, pp. 1–3.
- [49] P. Pursula et al., "Millimeter-wave identification-a new short-range radio system for low-power high data-rate applications," *IEEE Trans. Microw. Theory Techn.*, vol. 56, no. 10, pp. 2221–2228, Oct. 2008.
- [50] J. G. Hester and M. M. Tentzeris, "Inkjet-printed flexible mm-wave Van-Atta reflectarrays: A solution for ultralong-range dense multitag and multisensing chipless RFID implementations for IoT smart skins," *IEEE Trans. Microw. Theory Techn.*, vol. 64, no. 12, pp. 4763–4773, Dec. 2016.
- [51] J. Hester and M. Tentzeris, "Inkjet-printed Van-Atta reflectarray sensors: A new paradigm for long-range chipless low cost ubiquitous smart skin sensors of the Internet of Things," in *Proc. IEEE MTT-S Int. Microw. Symp.*, 2016, pp. 1–4.
- [52] J. G. Hester and M. M. Tentzeris, "A mm-wave ultra-long-range energy-autonomous printed RFID-enabled Van-Atta wireless sensor: At the crossroads of 5G and IoT," in *Proc. IEEE MTT-S Int. Microw. Symp.*, 2017, pp. 1557–1560.
- [53] A. O. Adeyeye, J. Hester, and M. M. Tentzeris, "Miniaturized millimeter wave RFID tag for spatial identification and localization in Internet of Things applications," in *Proc. IEEE 49th Eur. Microw. Conf.*, 2019, pp. 105–108.
- [54] A. Eid, J. Hester, and M. M. Tentzeris, "A scalable high-gain and large-beamwidth mm-wave harvesting approach for 5G-powered IoT," in *Proc. IEEE MTT-S Int. Microw. Symp.*, 2019, pp. 1309–1312.
- [55] A. Eid, J. G. Hester, and M. M. Tentzeris, "5 G as a wireless power grid," *Sci. Rep.*, vol. 11, 2021.
- [56] A. Eid, J. G. Hester, and M. M. Tentzeris, "Rotman lens-based wide angular coverage and high-gain semipassive architecture for ultralong range mm-wave RFIDS," *IEEE Antennas Wireless Propag. Lett.*, vol. 19, no. 11, pp. 1943–1947, Nov. 2020.
- [57] M. Alhassoun, M. A. Varner, and G. D. Durgin, "Theory and design of a retrodirective rat-race-based RFID tag," *IEEE J. Radio Freq. Identif.*, vol. 3, no. 1, pp. 25–34, Mar. 2019.
- [58] M. S. Trotter, C. R. Valenta, G. A. Koo, B. R. Marshall, and G. D. Durgin, "Multi-antenna techniques for enabling passive RFID tags and sensors at microwave frequencies," in *Proc. IEEE Int. Conf. RFID*, 2012, pp. 1–7.
- [59] J. Kimionis, A. Georgiadis, S. Kim, A. Collado, K. Niotaki, and M. M. Tentzeris, "An enhanced-range RFID tag using an ambient energy powered reflection amplifier," in *Proc. IEEE MTT-S Int. Microw. Symp.*, 2014, pp. 1–4.
- [60] F. Amato, C. W. Peterson, M. B. Akbar, and G. D. Durgin, "Long range and low powered RFID tags with tunnel diode," in *Proc. IEEE Int. Conf. RFID Technol. Appl.*, 2015, pp. 182–187.
- [61] A. Eid, J. Hester, and M. M. Tentzeris, "A 5.8 GHz fully-tunnel-diodes-based 20 μ W, 88 mV, and 48 dB-gain fully-passive backscattering RFID tag," in *Proc. IEEE/MTT-S Int. Microw. Symp.*, 2020, pp. 607–610.
- [62] V. Iyer, J. Chan, and S. Gollakota, "3D printing wireless connected objects," *ACM Trans. Graph.*, vol. 36, no. 6, Nov. 2017. [Online]. Available: <https://doi.org/10.1145/3130800.3130822>
- [63] B. Kellogg, V. Talla, G. S., and J. R. Smith, "Passive wi-fi: Bringing low power to wi-fi transmissions," in *Proc. USENIX Symp. Netw. Syst. Des. Implement.*, 2016, pp. 38–41.
- [64] Y. Ding, R. Lihakanga, R. Correia, G. Goussetis, and N. B. Carvalho, "Harmonic suppression in frequency shifted backscatter communications," *IEEE Open J. Commun. Soc.*, vol. 1, pp. 990–999, 2020.
- [65] R. Correia, A. Boaventura, and N. BorgesCarvalho, "Quadrature amplitude backscatter modulator for passive wireless sensors in IoT applications," *IEEE Trans. Microw. Theory Techn.*, vol. 65, no. 4, pp. 1103–1110, Apr. 2017.
- [66] Y. Ding, G. Goussetis, R. Correia, R. Lihakanga, N. BorgesCarvalho, and P. Petridis, "Enabling multicarrier backscattering communications," in *Proc. IEEE MTT-S Int. Wireless Symp.*, 2020. [Online]. Available: <http://www.em-conf.com/iws2020/>
- [67] J. F. Ensworth and M. S. Reynolds, "Every smart phone is a backscatter reader: Modulated backscatter compatibility with bluetooth 4.0 low energy (BLE) devices," in *Proc. IEEE Int. Conf. RFID*, 2015, pp. 78–85.
- [68] J. F. Ensworth and M. S. Reynolds, "BLE-backscatter: Ultralow-power IoT nodes compatible with bluetooth 4.0 low energy (BLE) smartphones and tablets," *IEEE Trans. Microw. Theory Techn.*, vol. 65, no. 9, pp. 3360–3368, Sep. 2017.
- [69] Y. Peng et al., "Plora: A passive long-range data network from ambient lora transmissions," in *Proc. Conf. ACM Special Int. Group Data Commun.*, 2018, pp. 147–160. [Online]. Available: <https://doi.org/10.1145/3230543.3230567>
- [70] V. Talla, M. Hesar, B. Kellogg, A. Najafi, J. R. Smith, and S. Gollakota, "Lora backscatter: Enabling the vision of ubiquitous connectivity," *Proc. ACM Interact. Mob. Wearable Ubiquitous Technol.*, vol. 1, no. 3, Sep. 2017. [Online]. Available: <https://doi.org/10.1145/3130970>
- [71] D. Belo et al., "IQ impedance modulator front-end for low-power lora backscattering devices," *IEEE Trans. Microw. Theory Techn.*, vol. 67, no. 12, pp. 5307–5314, Dec. 2019.
- [72] R. Duan, X. Wang, H. Yigitler, M. U. Sheikh, R. Jantti, and Z. Han, "Ambient backscatter communications for future ultra-low-power machine type communications: Challenges, solutions, opportunities, and future research trends," *IEEE Commun. Mag.*, vol. 58, no. 2, pp. 42–47, Feb. 2020.



RICARDO TORRES (Student Member, IEEE) received the M.Sc. degree in electronics and telecommunications engineering from the University of Aveiro, Aveiro, Portugal, in 2020, where he is currently working toward the Ph.D. degree. Since 2019, he has been a Researcher with the Instituto de Telecomunicações. His main research interests include microwave electronic circuits, backscatter communication, and software defined radio.

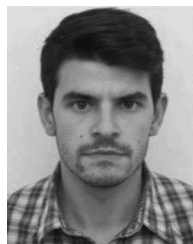

RICARDO CORREIA (Member, IEEE) received the M.Sc. degree in electronics and telecommunications engineering and the Ph.D. degree in electrical engineering from the University of Aveiro, Aveiro, Portugal, in 2009 and 2019, respectively. He was an Automation and Electrical Engineer and a Researcher of embedded systems and signal processing. He is currently a Researcher with Sinuta SA. Estarreja, Aveiro, Portugal, where he works on transmission and reception system of electronically oriented signals for next generation satellite

constellations. He is also a Collaborator with the Institute of Telecommunications, University of Aveiro. His current research interests include wireless power transfer, energy harvesting, wireless passive sensors for space applications, and low power communications. He is a member of the IEEE Microwave Theory and Techniques Society. He is also a reviewer of *IET Microwaves, Antennas and Propagation*, *Wireless Power Transfer Journal*, and *IEEE TRANSACTIONS ON MICROWAVE THEORY AND TECHNIQUES*. He was the recipient of the 2016 URSI/ANACOM Prize awarded by the URSI Portuguese Section and Portuguese National Authority of Communications and second place in the Ph.D. category of the 2019 Fraunhofer Portugal challenge.



NUNO BORGES CARVALHO (Fellow, IEEE) was born in Luanda, Angola, in 1972. He received the Diploma and Doctoral degrees in electronics and telecommunications engineering from the University of Aveiro, Aveiro, Portugal, in 1995 and 2000, respectively. He is currently a Full Professor and a Senior Research Scientist with the Institute of Telecommunications, University of Aveiro. He has coauthored the books *Intermodulation Distortion in Microwave and Wireless Circuits* (Artech House, 2003), *Microwave and Wireless Measurement Techniques* (Cambridge University Press, 2013), *White Space Communication Technologies* (Cambridge University Press, 2014), and *Wireless Power Transmission for Sustainable Electronics* (Wiley, 2020). He is a reviewer and author of more than 200 papers in magazines and conferences. He is the Editor-in-Chief and an Associate Editor for *IEEE Microwave Magazine* and former Associate Editor for *IEEE TRANSACTIONS ON MICROWAVE THEORY AND TECHNIQUES* and *IET Microwaves Antennas and Propagation Journal*. He is the co-inventor of six patents. His main research interests include software-defined radio front-ends, wireless power transmission, nonlinear distortion analysis in microwave/wireless circuits and systems, and measurement of nonlinear phenomena. He has recently been involved in the design of dedicated radios and systems for newly emerging wireless technologies. Dr. Borges Carvalho is a member of IEEE MTT ADCOM; Past-Chair of the IEEE Portuguese Section, MTT-20 and MTT-11; and also belongs to technical committees MTT-24 and MTT-26. He is also the Vice-Chair of the URSI Commission A (Metrology Group). He was the recipient of the 1995 University of Aveiro and the Portuguese Engineering Association Prize for the best 1995 student at the University of Aveiro, the 1998 Student Paper Competition (Third Place) of the IEEE Microwave Theory and Techniques Society (IEEE MTT-S) International Microwave Symposium (IMS), and the 2000 IEE Measurement Prize. He was a Distinguished Microwave Lecturer for the IEEE Microwave Theory and Techniques Society.



SPYRIDON DASKALAKIS (Member, IEEE) was born in Heraklion, Greece, in 1991. He received with excellence the Engineering Diploma and M.Sc. degrees in electrical and computer engineering from the Technical University of Crete, Chania, Greece, in 2014 and 2016, respectively, and the Ph.D. degree in electrical engineering from the School of Engineering and Physical Sciences, Heriot-Watt University, Edinburgh U.K. He is currently a Hardware Design Engineer with Celestia, U.K. His current research interests include low power, low-cost wireless sensor networks, and energy harvesting. He was the recipient of the Fellowship Award from the Clinton Global Initiative University 2014 (USA), the Onassis Foundation (graduate studies 2015/16 scholarship), the Lloyds Register Foundation (LRF), and the International Consortium in Nanotechnology (ICON). He was the recipient of the two short-term scientific mission grants from COST Action IC1301 WiPE in School of Electrical and Computer Engineering, Georgia Institute of Technology, Atlanta, GA, USA, in 2016, and the Centre Tecnologic de Telecomunicacions de Catalunya, Barcelona in 2015. He was also the recipient of the MTT-S Graduate Fellowship for 2019 from the IEEE Microwave Theory and Techniques Society and recipient of the 1st and 2nd Year Postgraduate Research Prizes from Heriot-Watt University.



GEORGE GOUSSETIS (Senior Member, IEEE) received the Diploma degree in electrical and computer engineering from the National Technical University of Athens, Greece, in 1998 and the Ph.D. degree from the University of Westminster, London, U.K., in 2002. In 2002, he also graduated with the B.Sc. degree in physics (first class) from the University College London, U.K. In 1998, he joined the Space Engineering, Rome, Italy, as RF Engineer and in 1999 the Wireless Communications Research Group, University of Westminster, U.K., as a Research Assistant. Between 2002 and 2006, he was a Senior Research Fellow with Loughborough University, U.K. He was a Lecturer (Assistant Professor) with Heriot-Watt University, Edinburgh, U.K., between 2006 and 2009 and a Reader (Associate Professor) with Queen's University Belfast, U.K., between 2009 and 2013. In 2013, he joined Heriot-Watt, as a Reader and was promoted to a Professor in 2014, where he currently directs the Institute of Sensors Signals and Systems. He has authored or coauthored more than 500 peer-reviewed papers five book chapters one book and four patents. His research interests include microwave and antenna components and subsystems. Dr. Goussetis has held a Research Fellowship from the Onassis foundation in 2001, a Research Fellowship from the U.K. Royal Academy of Engineering between 2006 to 2011 and European Marie-Curie experienced Researcher fellowships in 2011-2012 and again in 2014-2017. He was the co-recipient of the 2011 European Space Agency young engineer of the year prize, the 2011 EuCAP Best Student Paper Prize, the 2012 EuCAP Best Antenna Theory Paper Prize, and the 2016 Bell Labs Prize. He was an Associate Editor for *IEEE ANTENNAS AND WIRELESS PROPAGATION LETTERS*.



YUAN DING (Member, IEEE) received the bachelor's degree in electronic engineering from Beihang University, Beijing, China, in 2004, the master's degree in electronic engineering from Tsinghua University, Beijing, China, in 2007, and the Ph.D. degree in electronic engineering from the Queen's University of Belfast, Belfast, U.K., in 2014. He was a Radio Frequency (RF) Engineer with Motorola R&D Centre, Beijing, China, from 2007 to 2009, before joining Freescale Semiconductor Inc., Beijing, China, as an RF Field Application Engineer, responsible for high power base-station amplifier design, from 2009 to 2011. He is currently an Assistant Professor with the Institute of Sensors, Signals and Systems, Heriot-Watt University, Edinburgh, U.K. His research interests include IoT-related physical-layer designs, antenna array, physical layer security, and 5G related areas. Dr. Ding was the recipient of the IET Best Student Paper Award at LAPC 2013 and the recipient of the Young Scientists Awards in General Assembly and Scientific Symposium (GASS), 2014 XXXIst URSI.



APOSTOLOS GEORGIADIS (Fellow, IEEE) received the Ph.D. degree in electrical engineering from the University of Massachusetts, Amherst, MA, USA. He has held positions as a System Engineer within industry in the United States and as a Senior Researcher and a Group Leader in microwave subsystems in Spain. From 2016 to 2017, he was an Associate Professor with Heriot-Watt University, Edinburgh, U.K. He is currently a Patent Examiner with European Patent Office. He has authored more than 200 articles in peer-reviewed journals and international conferences. His current research interests include energy harvesting and wireless power transfer, RFID technology, active antennas, and inkjet and 3-D printed electronics. Dr. Georgiadis was a Fulbright Fellow and an EU Marie Curie Global Fellow. His research was the recipient of several Best Paper Awards and the 2016 Bell Labs Prize. He was an Associate Editor for *IET Microwaves, Antennas and Propagation* and *IEEE MICROWAVE AND WIRELESS COMPONENTS LETTERS*. He co-founded and was the Editor-in-Chief of *Wireless Power Transfer*. He was a Distinguished Lecturer of the IEEE Council on RFID. He is a URSI Fellow and the 2017–2020 Chair of the URSI Commission D.



ALINE EID (Student Member, IEEE) received the B.Eng. and M.S. degrees in electrical and computer engineering from Notre Dame University, Louaize, Lebanon and the American University of Beirut, Lebanon, in 2015 and 2017, respectively. She is currently working toward the Ph.D. degree in electrical engineering in the ATHENA Group led by Prof. Manos Tentzeris, with the Georgia Institute of Technology, Atlanta, GA, USA. She is the author or coauthor of more than 30 conference and journal papers and book chapters, and an inventor in four patents. Her research interests include electromagnetics and microwave/millimeter-wave devices and systems, intelligent, autonomous, human-aware systems and communications and networking, zero-power mm-wave-enabled solutions for smart environments, and autonomous robots and vehicles. During her Ph.D., she was the recipient of more than 12 awards. She was the recipient of the NSF travel and Best Paper Awards at the 2018 IEEE NMDC conference, travel award and honorable mention in the student paper competition at the 2019 IEEE APS/URSI conference. At the 2019 IEEE IMS conference, she won the first place in the RFID student design competition, a second place and audience choice in the 3MT competition and an honorable mention in the student paper competition. She was also the recipient of the 2020 IEEE MTT-S graduate fellowship and Tom Brazil Awards and the first-place award in the student poster competition at the 2020 FLEX MEMS Sensors Technical Congress.



JIMMY HESTER (Member, IEEE) received the M.S. and Ph.D. degrees in electrical and computer engineering from Georgia Institute of Technology, Atlanta, GA, USA, in 2014 and 2019, respectively. He is currently a Co-Founder of Atheraxon, Atlanta, GA, USA, the company commercializing the 5G RFID technology. He has been developing solutions for the use of carbon nanomaterials and also optimized RF structures toward the implementation of inkjet-printed flexible low-cost ubiquitous gas sensors for the Internet of Things and smart skin applications. His work covers the entire development process, from the development of inkjet inks, improvement of fabrication methods, sensor component design, high-frequency characterization and environmental testing to the design, simulation, and fabrication of the RF system embedding the sensor, and the development of wireless reading and data processing schemes. His research interests include interface between radio frequency and millimeter-wave engineering and material science, in the form of flexible electronics technologies and nanotechnologies. Dr. Hester was awarded the 2015 NT4D Student Award, the 2nd Place Best Poster Award at the 2017 IEEE Futurecar Conference, the 3rd Place Best Poster Award at the 2017 Flex Conference, and the Honorable Mention Award as finalist of the 2017 IMS Student Paper Competition.



MANOS M. TENTZERIS (Fellow, IEEE) received the Diploma degree (*magna cum laude*) in electrical and computer engineering from the National Technical University of Athens, Athens, Greece, and the M.S. and Ph.D. degrees in electrical engineering and computer science from the University of Michigan, Ann Arbor, MI, USA, in 1994 and 1998, respectively. He was a Visiting Professor with the Technical University of Munich, Munich, Germany, in 2002, GTRI-Ireland, Athlone, Ireland, in 2009, and LAAS-CNRS, Toulouse, France, in

2010. He was the Head of the GTECE Electromagnetics Technical Interest Group, the Associate Director of RFID/Sensors research of the Georgia Electronic Design Center, the Associate Director of RF Research of the Georgia Institute of Technology NSF-Packaging Research Center, and the RF Alliance Leader. He is currently a Ken Byers Professor of flexible electronics with the School of Electrical and Computer Engineering, Georgia Institute of Technology, Atlanta, GA, USA, where he heads the ATHENA Research Group (20 researchers). He has helped develop academic programs in 3-D/inkjet-printed radio frequency (RF) electronics and modules, flexible electronics, origami and morphing electromagnetics, highly integrated/multilayer packaging for RF and wireless applications using ceramic and organic flexible materials, paper-based RFIDs and sensors, wireless sensors and biosensors, wearable electronics, Green electronics, energy harvesting and wireless power transfer, and nanotechnology applications in RF, microwave MEMs, and SOP-integrated (UWB, multiband, millimeter wave, and conformal) antennas. He has authored more than 800 papers in refereed journals and conference proceedings, five books, and 25 book chapters. Dr. Tentzeris is a member of The URSI-Commission D, the MTT-15 Committee, and the Technical Chamber of Greece; an Associate Member of EuMA; and a Fellow of The Electromagnetics Academy. He was the recipient/co-recipient of the 2019 Humboldt Research Prize, the 2017 Georgia Institute of Technology Outstanding Achievement in Research Program Development Award, the 2016 Bell Labs Award Competition 3rd Prize, the 2015 IET Microwaves, Antennas, and Propagation Premium Award, the 2014 Georgia Institute of Technology ECE Distinguished Faculty Achievement Award, the 2014 IEEE RFID-TA Best Student Paper Award, the 2013 IET Microwaves, Antennas and Propagation Premium Award, the 2012 FiDiPro Award in Finland, the iCMG Architecture Award of Excellence, the 2010 IEEE Antennas and Propagation Society Piergiorgio L. E. Uslenghi Letters Prize Paper Award, the 2011 International Workshop on Structural Health Monitoring Best Student Paper Award, the 2010 Georgia Institute of Technology Senior Faculty Outstanding Undergraduate Research Mentor Award, the 2009 IEEE TRANSACTIONS ON COMPONENTS AND PACKAGING TECHNOLOGIES Best Paper Award, the 2009 E. T. S. Walton Award from the Irish Science Foundation, the 2007 IEEE AP-S Symposium Best Student Paper Award, the 2007 IEEE MTT-S IMS Third Best Student Paper Award, the 2007 ISAP 2007 Poster Presentation Award, the 2006 IEEE MTT-S Outstanding Young Engineer Award, the 2006 Asia-Pacific Microwave Conference Award, the 2004 IEEE TRANSACTIONS ON ADVANCED PACKAGING Commendable Paper Award, the 2003 NASA Godfrey Artz Anzic Collaborative Distinguished Publication Award, the 2003 IBC International Educator of the Year Award, the 2003 IEEE CPMT Outstanding Young Engineer Award, the 2002 International Conference on Microwave and Millimeter-Wave Technology Best Paper Award, Beijing, China, the 2002 Georgia Institute of Technology-ECE Outstanding Junior Faculty Award, the 2001 ACES Conference Best Paper Award, the 2000 NSF CAREER Award, and the 1997 Best Paper Award of the International Hybrid Microelectronics and Packaging Society. He was the TPC Chair of the IEEE MTT-S IMS 2008 Symposium and the Chair of the 2005 IEEE CEM-TD Workshop. He is the Vice-Chair of the RF Technical Committee (TC16) of the IEEE CPMT Society. He is the Founder and the Chair of the RFID Technical Committee (TC24) of the IEEE MTT-S and the Secretary/Treasurer of the IEEE C-RFID. He is also an Associate Editor for IEEE TRANSACTIONS ON MICROWAVE THEORY AND TECHNIQUES, IEEE TRANSACTIONS ON ADVANCED PACKAGING, and *International Journal on Antennas and Propagation*. He has given more than 100 invited talks to various universities and companies all over the world. From 2010 to 2012, he has served as one of the IEEE MTT-S Distinguished Microwave Lecturers. He is one of the IEEE CRFID Distinguished Lecturers.