

Circuit Type Multiple Beamforming Networks for Antenna Arrays in 5G and 6G Terrestrial and Non-Terrestrial Networks

Y. JAY GUO ¹ (Fellow, IEEE), MARAL ANSARI ¹ (Student Member, IEEE),
AND NELSON J. G. FONSECA ² (Senior Member, IEEE)

(Invited Paper)

¹Global Big Data Technologies Centre, University of Technology Sydney, Ultimo, NSW 2007, Australia

²Antenna and Sub-Millimetre Waves Section, European Space Agency, 2200 Noordwijk, The Netherlands

CORRESPONDING AUTHOR: Y. JAY GUO (e-mail: Jay.Guo@uts.edu.au).

ABSTRACT To support the ever-increasing demand on connectivity and data rates, multiple beam antennas are identified as a critical technology for the fifth generation (5G), the sixth generation (6G) and more generally beyond 5G (B5G) wireless communication links in both terrestrial networks (TNs) and non-terrestrial networks (NTNs). To reduce the cost and power consumption, there is a marked industrial interest in adopting analogue multiple beam antenna array technology. A key sub-system in many of such antenna arrays is the circuit type multiple beamforming network (BFN). This has led to a significantly renewed interest in and new technological developments of Butler matrices, Blass matrices, and Nolen matrices as well as hybrid structures, mostly at millimeter-wave frequencies. To the best of the authors' knowledge, no comprehensive analysis and comparison of circuit type multiple BFNs have been properly reported with focus on 5 G and 6 G applications to date. In this paper, the principle of operation, design, and implementation of different circuit type multiple BFNs are discussed and compared. The suitability of these sub-systems for 5 G and B5G antenna arrays is reviewed. Major technology and research challenges are highlighted. It is expected that this review paper will facilitate further innovation and developments in this important field.

INDEX TERMS Fifth generation (5G), sixth generation (6G), beyond 5G (B5G), multiple beam antenna arrays, circuit type beamforming networks (BFNs), Blass matrix, Butler matrix, Nolen matrix, terrestrial network (TN), non-terrestrial network (NTN).

I. INTRODUCTION

The global deployment of the fifth generation (5G) of wireless and mobile communication systems is accelerating, and the technical race on the sixth generation (6G) has started in earnest in many parts of the world [1], [2]. 5G promises significantly increased capacity, massive connectivity, low latency, and game-changing new applications [3]. 6G is expected to provide much greater coverage, significantly reduced cost and energy consumption, and higher intelligence empowered by machine learning technologies [4]. The ambition to provide global and seamless connectivity calls for the integration of non-terrestrial networks (NTNs), capable of extending and complementing terrestrial networks (TNs) in areas underserved or out of reach [5]–[7]. This includes airborne and

spaceborne networks in a multi-layer communication architecture, with studies recently initiated on the topic by the 3rd Generation Partnership Project (3GPP) to elaborate requirement use scenarios [8], [9].

At the core of 5G and beyond 5G (B5G) systems are multi-beam antenna arrays which enable unprecedented connectivity and high spectrum efficiency [10]–[12]. Digital beamforming, including Multiple-Input-Multiple-Output (MIMO) signal processing, is the most flexible approach for generating individually steerable multiple beams. Undoubtedly, fully digital beamforming with massive antenna arrays serves as a powerful technology to meet some of the most challenging desired features of future wireless communication networks, particularly in rich scattering environments [1]. However, this

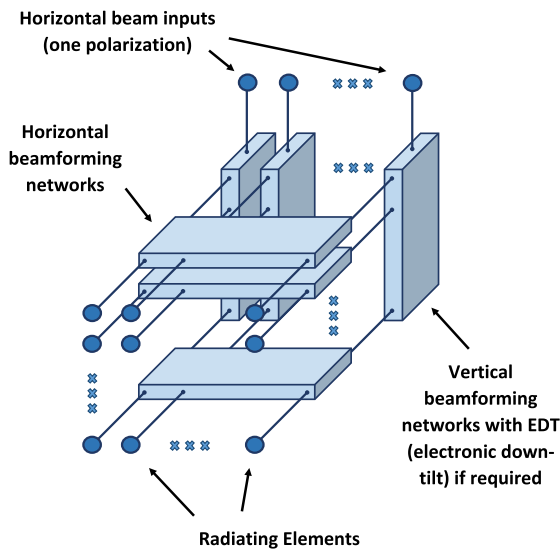

FIGURE 1. General Layout of a multibeam cellular antenna using 1D circuit type BFNs.

approach generally leads to high power consumption and hardware cost, which prevent its use in applications such as large-scale low-cost networking as well as small airborne and space-borne platforms with limited power supply. Quasi-optical techniques also serve as an alternative analogue beamforming technology. However, they are more suited for higher mm-wave and terahertz (THz) frequencies, as the line of sight (LoS) wave propagation becomes dominant. A cost and energy efficient solution well fitting the microwave domain is analogue multiple beam antenna arrays based on circuit type beamforming networks (BFN). Such BFNs typically consist of fundamental microwave/millimeter-wave (mm-wave) circuit components such as power dividers, couplers, crossovers, phase shifters and switches. The best known circuit type BFN is the Butler matrix [13], [14], while the Nolen matrix is emerging as an attractive alternative [15], [16]. When integrated properly with antenna arrays, circuit type BFNs can deliver superior performance at low-cost and with moderate power consumption.

A conceptual layout of a multibeam cellular antenna using one dimensional (1D) circuit type BFNs is shown in Fig. 1 where the azimuth sector is divided into several cells. Horizontal linear arrays are fed with horizontal networks which produce a set of beams in the azimuth plane. Separate inputs to the horizontal network excite the separate beams. The inputs to the horizontal networks that apply to a particular azimuth beam are excited in the normal way by a vertical network comprising a power divider with or without electrical down-tilt which forms the elevation pattern for the particular azimuth beam. The stack of horizontal arrays operates as a planar array with beamforming in both azimuth and elevation. Separate vertical networks are required for each azimuth beam and each polarization [17].

Another existing application of multiple BFNs is where an area of extremely high traffic density must be served from a

single point. This frequently arises in the context of open-air events such as music concerts and sports competitions. Different sectors of the crowd are covered by separate multiple narrow beams. Because these events are often one-time or annual events, there is growing interest in high capacity cell-on-wheels (COW) systems with a multiple BFN solution providing horizontally sectorized multiple cell coverage. These can be moved in to cover the particular event. Ad-hoc networks are also primordial in emergency scenarios, where the TN is disrupted by unforeseen circumstances such as natural disasters and power outage. The deployment of a temporary aerial base station (BS) can provide the connectivity required to facilitate first aid intervention.

For 5G and B5G, there are new challenges for multiple BFNs. They need to be flexible to support unequal input and output ports as well as arbitrary beam directions, accommodate two dimensional (2D) beamforming, be compact, highly integrated and multiband or wideband. It is also expected that most of the multiple BFNs will be at mm-wave frequencies [18]. This calls for innovative designs of Butler matrices, Nolen matrices and various hybrid configurations. To this end, this paper provides a comprehensive review of various circuit type BFNs. Different solutions and their basic operating principle, application, and performance are classified and compared. Latest developments are reported, with particular focus on printed circuit board (PCB) technology, and current research challenges are discussed. Methods to enhance the performance of antenna arrays based on circuit type BFNs, including the antenna gain, the efficiency, the scanning range, the side lobe levels, etc., are presented, and several examples, mainly for applications in cellular communication systems, are given. To the best of our knowledge, this is the first comprehensive review of circuit type BFNs covering various approaches to support current and future wireless communication systems.

II. CIRCUIT TYPE BEAMFORMING NETWORKS

A. GENERAL DEFINITIONS

A circuit type BFN is a physical layer element of an array system that distributes signals with the amplitudes and phases required to produce a desired angular distribution of emitted radiation, when operating in transmission. A 1D BFN is generally connected to a linear array, defined as a set of N elementary antennas, arranged along a given axis. The output ports of the BFN are often referred to as array ports. The BFN also has M input ports, or beam ports, as each port provides the excitations to form a given beam. Both M and N are integers and the BFN is often described as a $M \times N$ device. A multibeam antenna is realized if all of the input ports are driven simultaneously. One beam can also be synthesized exciting multiple inputs with the same signal. In reception, the BFN combines impinging signals in a reciprocal way, as it is generally a passive device. Using well-established PCB technologies, BFNs can be fully integrated with an array of

antennas into a single substrate, providing cost-effective solutions.

A circuit type BFN is fully characterized by its reduced scattering matrix, S , with dimensions $N \times M$ and containing the array coefficients in transmit, such that $\mathbf{b} = S \mathbf{a}$, where \mathbf{a} and \mathbf{b} are the network input and output complex amplitude vectors of dimension M and N , respectively. In other words, the component a_i , $i = 1 \dots M$, of the vector \mathbf{a} corresponds to the complex electric field amplitude applied at the i^{th} input port, while the component b_j , $j = 1 \dots N$, of the vector \mathbf{b} corresponds to the complex electric field amplitude delivered to the j^{th} output port and corresponding array element. The remaining terms of the complete scattering matrix are generally neglected under assumption that all ports are matched and mutually decoupled between input ports and between output ports. When the matrix S is orthogonal, i.e. $S^T \cdot S^* = I$, where S^T and S^* are the transpose and complex conjugate of S , respectively, and I is the unitary matrix, the BFN is said to be theoretically lossless. This means that the BFN itself does not add losses besides ohmic losses introduced by the transmission line technology used to implement the circuit. In some cases, the BFN may be theoretically lossless in transmit and lossy in receive, or vice versa [19]. An orthogonal BFN produces orthogonal array coefficients, which produce in turn multiple orthogonal beams with constraints on pointing directions, side lobe levels and overlap between adjacent beams. These constraints on radiation patterns produced by orthogonal BFNs are well detailed in [20], [21]. In this section, the main circuit type BFNs are detailed.

B. THE BLASS MATRIX

Introduced in the early 1960's, the Blass matrix was the first described method to provide multiple beams for antenna systems [22]. It consists of an array of N radiating elements excited in series by M feeder lines. These lines are interconnected by directional couplers at their crossover points and they are terminated with matched loads at each line end, providing a travelling wave operation that facilitates the design.

A Blass matrix can be sized for use with any number of array elements and any number of beams. Unfortunately, due to the resistive terminations, the efficiency of the Blass matrix is generally low. The less orthogonal the reduced S matrix, the higher the losses. The size of the linear array also dictates the level of losses at the terminations. The larger the array, the lower the losses. The schematic of an M -input Blass matrix, as well as the associated notations and the details of a node, are shown in Fig. 2. A given node N_{mn} is constituted of a lossless directional coupler, having a coupling parameter θ_{mn} such that the coupled amplitude feeding the elementary antenna line n is equal to $\sin \theta_{mn}$ while the direct port amplitude which propagates to the next node on the feeder line m is $\cos \theta_{mn}$. This assumes the coupler is perfectly matched and the two inputs, and outputs respectively, are perfectly decoupled. The node also contains a phase shifter on the coupled port characterised by the angle ϕ_{mn} . The transmission coefficient between the input port m and the elementary antenna n may

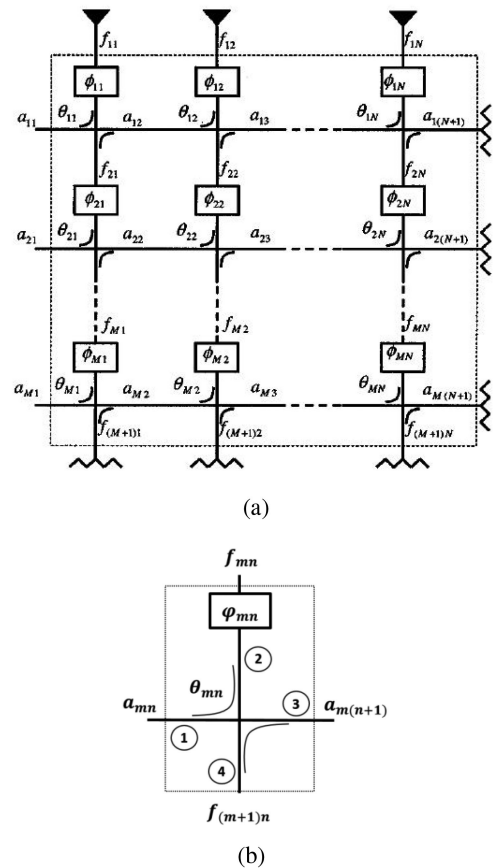

FIGURE 2. (a) Functional schematic representation of the M -entry Blass matrix and (b) details of a node [24].

be approximated by:

$$T_{mn} \approx j \sin \theta_{mn} e^{-j\phi_{mn}} \prod_{p=1}^{m-1} (e^{-j\phi_{pn}} \cos \theta_{pn}) \prod_{q=1}^{n-1} \cos \theta_{mq}, \quad (1)$$

with the convention that the products are equal to 1 when the lower index is higher than the upper index, i.e. when m and/or n are equal to 1. The formula is exact for the first line, $m = 1$, but neglects multipath in the network for $m > 1$. The approximation is acceptable for nodes with very low coupling level, typically required in large arrays. This provides an understanding of the illustration in the seminal paper by Blass [22] where the pointing of the beam is driven by the inclination of the feeder line, in first approximation. The length of the transmission lines in the network may be adjusted to provide true time delay operation, thus leading to frequency-independent beam directions [23].

The main advantages of the Blass matrix are the ability to generate multiple beams pointing in arbitrary directions, with flexibility on radiating pattern shapes and crossover levels. However, it exhibits higher losses due to the use of termination loads. These properties are mostly the consequence of the Blass matrix not being an orthogonal BFN. Ideally, one would like to design a Blass matrix, defining the parameters of the

nodes for a given set of desired excitation vectors, such as to minimize losses while accounting for multipath within the network. The general problem has no exact solution, except in the case of a two-beam Blass matrix design. The method was published by William R. Jones, with applications to monopulse radars [25]. More recently, Mosca *et al.* introduced a method in [24] that is applicable to any size of Blass matrix. It uses a set of independent (i.e. orthogonal) beams, or excitation vectors, that form a base describing all the desired non-independent beams. The power dissipation is minimized for the independent beams and not the desired beams, thus the solution is a good approximation but remains sub-optimal. The desired beams are generated as a linear combination of input beams, applying a set of complex input values as derived in [24].

Optical Blass matrices with potential for multibeam operation in next-generation cellular wireless systems have attracted much attention. Blass matrices based on optical phase shifters can ensure a fully flexible selection of the pointing angle of each wireless beam [26], [27]. In such designs, the Mach-Zehnder Interferometers serve as coupler inside the Blass matrix.

C. THE BUTLER MATRIX

The Butler matrix was first described by Jesse Butler and Ralph Lowe in [13], shortly after the introduction of the Blass matrix. The basic concept was also discussed at about the same time by J. Paul Shelton and Kenneth S. Kelleher in [28]. The fundamental difference between the Blass matrix and the Butler matrix is that the latter is essentially a parallel-fed BFN, while the former is a series-fed BFN. Allen [29] and Delaney [30] have published Butler matrix designs including precise values and location of all components. However, Moody [14] was the first to report a general and systematic design for Butler matrices in 1964. The development of the Butler matrix came in parallel with that of the Fast Fourier Transfer (FFT) [31], and the similarities between the two were quickly acknowledged [32], [33]. Although seldom used in that configuration, standard Butler matrices were also discussed in connection with planar arrays [34], and the connection with the multi-dimensional discrete Fourier transform (MD-DFT) was detailed more recently in [35]. The most widely used implementation of Butler matrices with planar arrays is based on a two-stack arrangement of linear BFNs, as described in the seminal paper by Butler and Lowe [13].

With the conventional form of Butler matrices, the number of inputs, M , is equal to the number of outputs, N , and it must be an integer power of 2 (i.e. $N = 2^n$, where n is an integer). This derives from the use of a 4-port coupler as elementary component [28]. The $N \times N$ Butler matrix produces N independent beams with phase progressions given by [14]

$$\Delta\phi = \frac{(2k - 1)\pi}{N}, k = 1 \dots N, \quad (2)$$

while amplitude is uniform (i.e. isophoric array configuration). Inputs and outputs are matched and isolated, and the

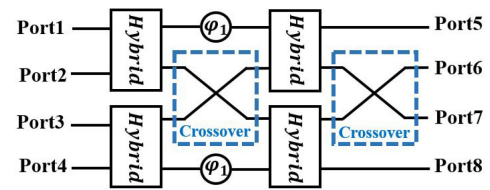

FIGURE 3. Schematic representation of the conventional symmetric 4×4 Butler matrix [13].

network is theoretically lossless [14]. There is no beam spacing loss due to the nature of orthogonal beams [20], [36]. This phase defined array configuration leads to frequency-dependent beam directions. A more general $M \times N$ Butler matrix is considered in some cases, simply over-sizing the matrix and terminating unused ports with matched loads. The layout may also be adjusted to more specific needs, in what is also referred to as multimode BFNs [37]. This includes the use of alternating division and combination functions, as also described in the seminal paper by Butler and Lowe [13], to produce cosine and square-cosine amplitude distributions. Variations of these BFNs, including so-called chess networks, have been reported in the literature [38]–[43]. In most of these variants, the orthogonality is compromised, either in transmit or in receive, or in both operation modes simultaneously, resulting in losses [19].

Typically, 4×4 Butler matrices are the most common form, because of their relatively simple structure [44]–[47]. Fig. 3 shows the schematic configuration of a conventional symmetric 4×4 Butler matrix. For practical communication systems, large arrays are required to increase the gain, reduce sidelobe levels (SLL), and have some control of the beam crossover level. While Butler matrices have significantly less components than Blass matrices for a same array size, their topology imposes transmission line crossovers, their number increasing drastically with the array size, thus compromising some of the benefits of Butler matrices in planar form.

D. THE NOLEN MATRIX

The Nolen matrix was first described in the Ph.D. dissertation of John C. Nolen, published in 1965 [15]. A schematic representation of its general layout is illustrated in Fig. 4. While the original dissertation is not easily accessible, a Technical Note by William C. Cummings from the MIT Lincoln Laboratory, published in 1978 and available online, provides some insight into the original work by Nolen [48]. The Nolen matrix is a general form of orthogonal BFN, based on a series-fed topology similar to that of the Blass matrix. Cummings described an iterative design procedure to define all the couplers and phase shifters constituting a Nolen matrix. He also demonstrated that a Nolen matrix may be simplified and eventually reduced to a Butler matrix when the number of ports is an integer power of 2. Thus, the Nolen matrix may be seen as an implementation of the general Discrete Fourier Transform

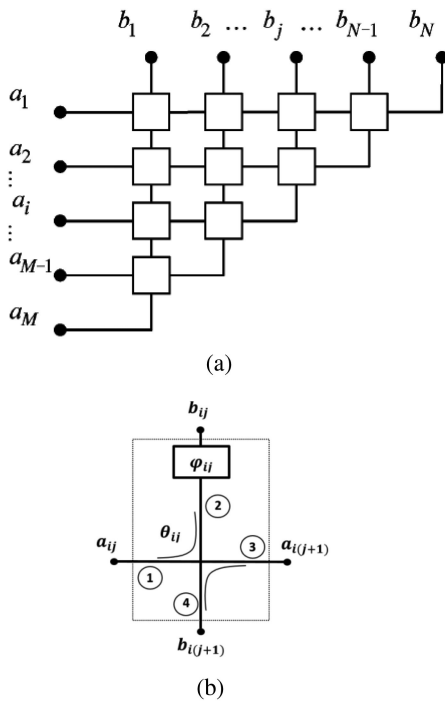

FIGURE 4. (a) Functional schematic representation of the M -entry Nolen matrix (b) Details of a node [16].

(DFT), in the same manner that the Butler matrix is an implementation of the FFT [49]. Being an orthogonal BFN, a $N \times N$ Nolen matrix will produce the same phase progressions as a Butler matrix, following eq. (2), with the important difference that there are no constraints on the possible values of N .

While the work of Cummings focused on the link between Nolen and Butler matrices, a more recent work revisited the design of Nolen matrices taking advantage of the similarities with Blass matrices [16]. Indeed, the Nolen matrix may be seen as a lossless variant of the Blass matrix in which all the directional couplers below the diagonal have been removed, and those on the diagonal are replaced by simple bends. Consequently, all the matched loads at the end of the feeder lines have also been removed. Using the method of Mosca *et al.* for Blass matrices with orthogonal excitations and setting the upper limit, $\sin \theta$, on coupling values close to one, i.e. $\sin \theta_{mn} < \sin \theta$, for $m = 1..M$ and $n = 1..N$ with $\sin \theta \approx 1$, the resulting design will approximate a Nolen matrix. Note that it is not possible to set the upper limit equal to one as the algorithm requires to divide by $\cos \theta$. However, considering typical numerical and experimental precision, the approximation is generally acceptable. Thus, the Nolen matrix may be considered as an asymptotic singular case of a Blass matrix with orthogonal excitations.

Reported designs [16], [50]–[53] indicate that Nolen matrices are comparable in complexity to their equivalent Butler matrices in planar realizations. An interesting feature of Nolen matrices is their capability to provide non-uniform amplitude

TABLE 1. Comparison of the Number of Components in Circuit Type BFNs

$M \times N$ Matrices	Number of couplers	Number of phase shifters
Blass matrix	$M(2N - M + 1)/2$	$M(2N - M + 1)/2$
Nolen matrix	NM	NM
Butler matrix	$Nn/2$	$N(n - 1)/2$

*The conventional Butler matrix implies a number of beams that is a power of 2, i.e. $M = N = 2^n$.

distributions, although constrained by the necessary condition of orthogonality. These works initiated by Fonseca *et al.* have triggered a regain of interest for Nolen matrices and designs are now being reported by other research groups [54]–[56].

III. COMPARISON OF CIRCUIT TYPE BEAMFORMING NETWORKS

The main circuit type BFNs discussed in Section II are compared here based on metrics of relevance for the targeted 5G and B5G applications, linked to size, weight, power and cost (SWaP-C) considerations of importance in modern product developments.

A. NUMBER OF COMPONENTS

The number of components necessary for designing different circuit type BFNs or matrices is an important factor in system designs. Besides the obvious impact on the design effort, affecting the final cost of the product through non-recurring engineering, it also constrains the footprint on a PCB and eventually the size and weight of the final product. In general, there is an interest in integrating the design as much as possible. With the same notations as in Section II, Table 1 compares the numbers of components implemented in different circuit type BFNs with M input ports and N output ports. It is assumed here that all ports of a conventional Butler matrix are used, i.e. $M = N$.

As anticipated in Section II, Butler matrices need less elements than Blass or Nolen matrices of equivalent size. In reality, however, the distinction is not quite so simple as a Butler matrix requires a large number of crossovers, necessitating a design with several layers. By contrast, the specific structured form of Blass and Nolen matrices leads to a simpler and straightforward planar design, so the Butler matrix turns out to be in some cases as complex as a Blass or Nolen matrix. To appreciate the complexity of the Butler matrix, a 32×32 Butler matrix is shown in Fig. 5.

In terms of design effort, there is also a difference between Butler matrices and Blass or Nolen matrices. Indeed, Butler matrices rely on hybrid couplers only, with all couplers being identical. This is not the case with Blass and Nolen matrices, as the series-fed structure requires a larger number of unbalanced coupler designs. The larger the array, the larger the range of unbalanced couplers required. A careful selection of the coupler technology is essential to enable the necessary coupling range. Alternatively, a tandem hybrid coupler configuration with adequate phase adjustment in between the two

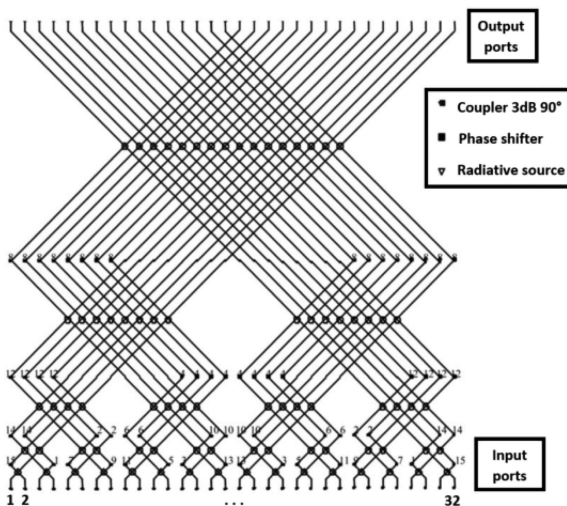

FIGURE 5. Schematic representation of 32×32 Butler matrix with hybrid couplers [49].

couplers may be used to produce unbalanced couplers [48], but this comes at the expense of a more complex implementation.

B. LOSSES

Another key element of comparison is the intrinsic losses of the circuit type BFN, which eventually will affect the power efficiency of the final product. As detailed in Section II, Blass matrices are lossy by design as they dissipate power in the matched loads that terminate the feeder lines, while Butler and Nolen matrices are theoretically lossless. For BFN designs with relatively small number of radiating elements and/or a relatively strong constraint on the directional couplers, losses in the matched loads may reach unacceptable levels. For this reason, Blass matrices are generally preferred for larger arrays, while Butler and Nolen matrices are more suited for smaller array designs, typically up to 16-element arrays in practice, considering a value that is a power of 2.

While Butler matrices are expected to be the most power efficient design, this may be compromised in the case of a multi-layer implementation, as layer-transitions will add to the BFN losses and alignment errors may impact the overall performance. In this respect, Nolen matrices may be seen as a better compromise between losses and complexity.

C. CONSTRAINTS ON THE EXCITATION

One considerable advantage of Blass and Nolen matrices over the Butler matrix is the possibility of realizing flexible amplitude excitations, while Butler matrices in their standard form impose a uniform amplitude excitation. In the case of Blass matrices, this flexibility comes at the expense of increased losses. The less orthogonal the excitations, the higher the losses. In the case of Nolen matrices, the excitations do not necessarily need to be uniform in amplitude, but they have to

be orthogonal. This condition is difficult to satisfy with multiple beams and this is the reason why most designs reported still assume a uniform amplitude distribution.

Orthogonal excitations have an impact on the beams, constraining side lobe levels, pointing directions, overlap between beams, etc. The link between lossless networks and radiation performance has been addressed in detail by Stein [20] and White [21]. In the case of linear arrays, a uniform excitation provides a first side lobe at about 13 dB below peak directivity, while beam overlap between adjacent beams produced by a lossless BFN is about 4 dB below peak directivity. For some applications, there may be an interest in reducing SLL to lower interference and/or increase the overlap between adjacent beams to reduce gain roll-off over the service area.

D. FREQUENCY BEHAVIOUR

A last factor for comparison is the frequency behaviour of these matrices. The topology presented for Blass or Nolen matrices has a naturally narrower frequency band than a Butler matrix. Indeed, the phase adjustment for all directional coupler outputs, before taking the phase shifters into account, can be applied rigorously only at the center frequency. The significant difference in electrical path length in series-fed BFNs implies that, when deviating from this design frequency, the matrix performance is degraded. This phenomenon does not occur in Butler matrices since the line lengths are all of the same order, by design. However, constant phase shift over frequency leads to frequency-dependent beam directions. While the resulting beam-squint may be acceptable within a limited fractional frequency bandwidth of typically 10 to 20%, this may become critical for wide band or even multiple-band designs. For such applications, Blass matrices may be preferable as they can be designed with time delay rather than phase delay [23].

Another point for consideration when discussing frequency behaviour is that most unbalanced coupler designs tend to have reduced bandwidth when compared to balanced couplers with similar technology. The larger the coupling unbalance, the narrower the frequency bandwidth. This may translate into a reduced frequency bandwidth with acceptable return loss or a more frequency-dependent coupling value. A careful selection of the coupler solution is required to overcome this limitation.

The advantages and disadvantages of each circuit type BFN are summarized in Table 2.

IV. METHODS TO ENHANCE THE PERFORMANCE OF CIRCUIT TYPE BEAMFORMING NETWORKS

Different multibeam array applications have distinct requirements. The efficiency of the design, operating frequencies and related fractional bandwidth, size and in some cases weight, SLL, crossover level and beamwidth, number of the beams, the ability to realize different polarizations, and wide scanning range are some of the essential requirements which must be taken into consideration in the design process.

TABLE 2. Comparison of Different Circuit Type BFNs

Network type	Advantages	Disadvantages
Bloss matrix	<ul style="list-style-type: none"> ✓ Flexibility in number of input and output ports ✓ Arbitrary beam directions and shapes ✓ No crossover ✓ Compatible with a time-delay design ✓ Easy and inexpensive fabrication 	<ul style="list-style-type: none"> × Lossy network and low efficiency × Multipath between feeding lines × Coupler design limitation × Narrow frequency bandwidth (design dependent)
Butler matrix	<ul style="list-style-type: none"> ✓ Theoretically lossless ✓ Minimum number of components (couplers and phase shifters) ✓ Simple structure ✓ Broad to wide frequency bandwidth ✓ Easy and inexpensive fabrication 	<ul style="list-style-type: none"> × Constrained number of ports × Large number of crossings or multi-layer design × Constrained frequency-dependent beam directions × High side lobe level
Nolen matrix	<ul style="list-style-type: none"> ✓ Flexibility in number of input and output ports ✓ Theoretically lossless (when number of inputs and outputs are equal) ✓ No crossover ✓ Broad to wide frequency bandwidth ✓ Easy and inexpensive fabrication 	<ul style="list-style-type: none"> × Partly constrained beam directions × Multipath between feeding lines × Coupler design limitation × Partly frequency-dependent beam directions × High side lobe level (design dependent)

For instance, in cellular base station applications, achieving multibeam sectorization over a $\pm 60^\circ$ azimuth coverage with -10 dB beam crossover levels are two crucial requirements. High gain and efficient antennas are always needed in the antenna systems to compensate for the dielectric and metallic losses. Such antennas are also desirable for compensation of high path losses, especially at mm-wave frequencies where the atmospheric attenuation rate is high due to the resonance of oxygen molecules. In the following section, some of the reported methods which can improve traditional designs to achieve specific requirements are reviewed.

A. LOWERING SIDE LOBE LEVEL

If the desired signal enters the main beam while interfering signals enter the sidelobes, then lowering the sidelobes relative to the main beam improves the signal to interference ratio in the receiver. This is desirable in all communication systems. The sidelobes are also unwanted for transmitters because they produce radiation in directions where there are no users. This could cause interference to other users and lead to unnecessary waste of energy. The optimum SLL of an N -element uniform array is about -13.6 dB [11]. However, many systems cannot achieve a SLL of less than -10 dB due to effects such as the mismatch between feeding network and antenna array and mutual coupling between elements [62].

Several techniques have been reported in the literature to reduce the SLL in beamforming antenna arrays. Reduced SLL for Butler matrix fed linear arrays was first introduced by Shelton. He showed the SLL of small linear arrays fed by a Butler matrix may be improved increasing the number of elements of the array and using the “covering condition” [63]. Using more elements is the first solution. However, this will increase the cost and complexity of the network. It also increases the size of the feed network.

Butler matrix designs utilizing power dividers to increase the number of array elements and to taper the amplitude across the antenna array have been reported in the literature [57],

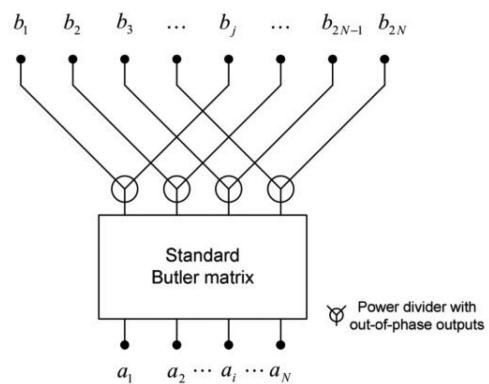

FIGURE 6. Schematic representation of modified Butler matrix utilized power dividers for tapered amplitude law [58].

[59], [64]–[66]. A schematic representation of the resulting BFN structure is shown in Fig. 6. Li *et al.* proposed a novel $N \times N$ Butler matrix using an additional circuit realized with equal ratio power dividers between the Butler matrix and radiating elements to feed a $2N$ array [64]. Such a circuit is simple but lossy and difficult to be integrated in a compact system. Fonseca and Ferrando demonstrated that the modified Butler matrix with low SLL may be replaced by a $N \times 2N$ Nolen matrix having similar properties [58]. The use of a Nolen matrix avoids the issues related to the additional crossovers introduced by the power dividers.

Tapered aperture illumination utilizing lossy networks has been reported in the literature [61], [67]–[69]. Another solution is the use of dissipative attenuators to achieve the desired amplitude distribution [70] where a combination of aperture attenuation and feed design, including the use of overlapping orthogonal feeds, is considered. External attenuators are associated with significant insertion losses and lower efficiencies. Arbitrary amplitude is generated using a 4×8 Butler matrix with Chebyshev distribution in [71]. The use of a four-port network and variable phase shifters provides -20 dB SLL. This value could reach -50 dB, only by altering the power

TABLE 3. Reported Techniques to Reduce the SLL in Circuit Type BFNs

Network type	Reference	Proposed technique	Frequency (GHz)	SLL (dB)	Crossover level (dB)
Butler matrix (4 × 8)	[57]	outphase power split	2.4	-20	-10
Nolen matrix (4 × 8)	[58]	tapered amplitude	4	-16	-
Butler matrix (4 × 8)	[59]	power split plus attenuator	-	-20	-10
Butler matrix (4 × 6)	[60]	tapered array	28	-10	-7
Butler matrix (4 × 4)	[61]	attenuator	28	-10	-4

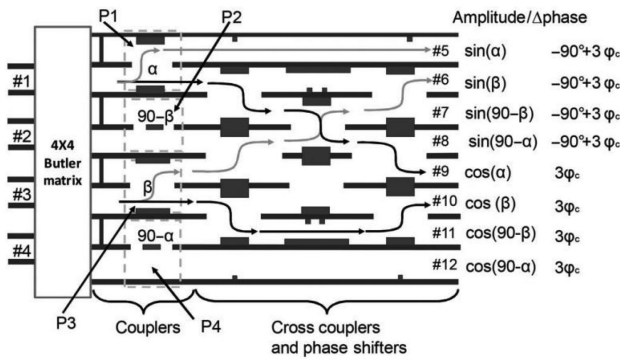

FIGURE 7. Circuit controlling the SLLs with Butler matrix. The values of the amplitude and phase distribution at the output ports are indicated on the right. ϕ_c stands for the phase of the cross coupler [73].

ratios of power splitters. In [72], the possibility of SLL reduction is investigated using multibeam conformal antenna arrays fed by a modified Butler matrix with compensating phase shifters and crossovers.

Tekkouk *et al.* [73] presented a mm-wave beamforming array based on a 4 × 4 Butler matrix using a dedicated circuit composed of four 90° couplers with different coupling factors (P1-P4), eight cross couplers, and phase shifters to control the SLL, as shown in Fig. 7. The beamforming antenna array can cover an angular area of ±43° with SLL less than -17.5 dB and beam overlap of -10 dB between adjacent beams over the entire scanning range.

It is to be noted that there is always a compromise between the SLL and crossover level relating to beamwidth, which should be considered for specific applications. This is a direct implication of the orthogonal excitations. A possible workaround is to use two interleaved arrays, thus achieving much higher overlap without compromising efficiency but at the cost of some hardware duplication [74]. To conclude the discussion, some reported circuit type BFNs with reduced SLL are compared in Table 3.

B. MINIATURIZING THE CIRCUIT LAYOUT

Bulky antennas cannot be easily integrated to practical wireless systems. Traditional designs of circuit type BFNs have bulky layouts when they employ more components for implementation in large arrays, and the technology used is typically transmission line-based. This may be problematic, especially at low frequencies. At mm-wave frequencies, insertion losses are prohibitive with traditional transmission line types, such as microstrip lines, and substrate integrated waveguide

(SIW) [75] becomes a serious alternative, albeit with a larger circuit footprint. Therefore, some effort has been made to achieve a level of miniaturization, across the frequency range of interest for wireless communication devices.

1) REDUCED NUMBER OF ELEMENTS

With the design of Butler matrices, crossovers have always been a problem, making the structure bulky. Butler matrices without crossovers were proposed in [76], [77] and without a 45° phase shifter in [78], [79]. A low-cost mm-wave 4 × 4 Butler matrix using microstrip technology is presented in [77], without any crossovers on a single layer. This topology is different from the traditional left-to-right arrangement of the basic components. It places the input ports on the outer side of the layout and the output ports on the inner side. Thus, there are no overlaps of the four signal paths. This topology was used for a SIW 4 × 4 Butler matrix in [80], including the antenna array, and it was extended to a 4 × 8 Butler matrix in [81] by introducing four power splitters in order to excite an eight-element array.

Ansari *et al.* [60] presented a microstrip-to-slot line transition to avoid the use of excessive crossovers in Butler matrices with a larger number of outputs. Their proposed structure is operating at 28 GHz with a size of 3.5λ × 1.5λ, which is only 50% of the area that an equivalent conventional matrix would occupy. The design architecture of a symmetrical 3 × 3 uniplanar Nolen matrix is introduced in [55]. Compared to previously reported 3 × 3 Nolen matrices, the design reduces the number of phase shifters and does not require outside phase compensation lines. The design architecture and the final prototype are shown in Fig. 8.

2) MULTI-LAYER CONFIGURATION

Another drawback of having an excessive number of components is the large footprint associated with the BFN layout. This issue can be resolved by using a multi-layer configuration which is facilitated by the development of SIW technologies. Since SIW is a closed structure, several layers can be directly stacked on top of each other without influencing the transmission performance. To demonstrate the reduction of the dimensions of a 4 × 4 Butler matrix, dual-layer configurations were developed in [82], [83]. There are two main advantages of using this dual-layer configuration. First, eliminating the crossovers leads to significantly shorter path lengths, thus, reducing the insertion losses. Second, it also reduces the in-plane footprint of the Butler matrix by half. Another example

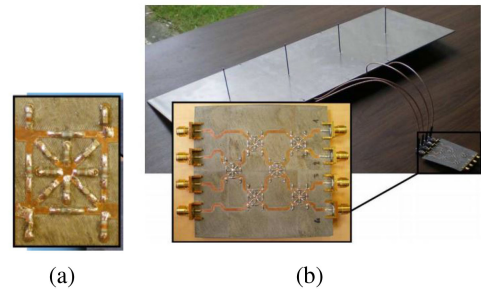
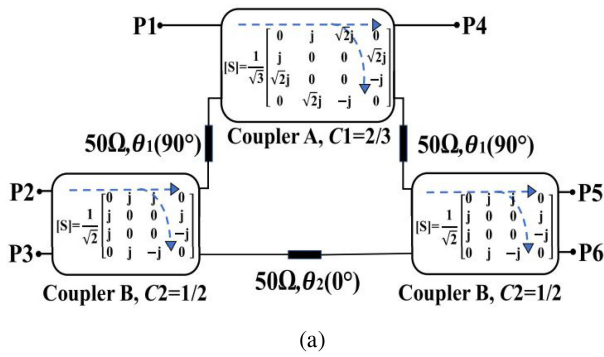

FIGURE 10. (a) Photograph of the coupler prototype. (b) Prototype of the 4 × 4 Butler matrix realized by lumped-element coupler connected to a monopole array [86].

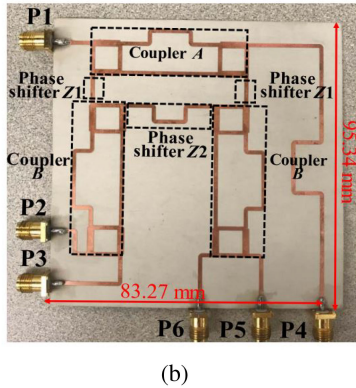

FIGURE 8. (a) Architecture of the symmetrical 3 × 3 Nolen matrix (b) Photograph of the fabricated the 3 × 3 Nolen matrix [55].

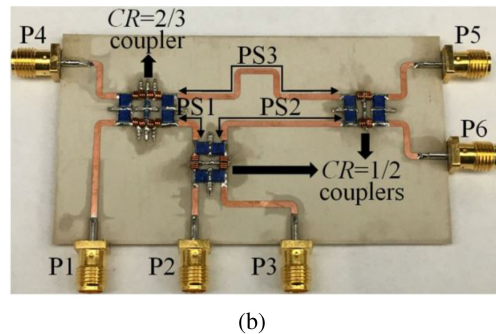
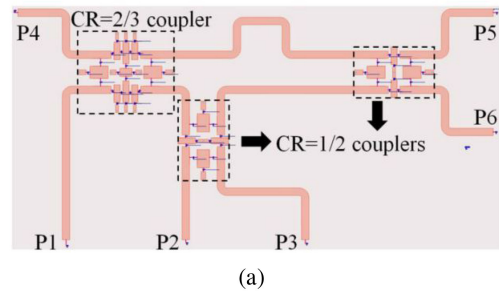

FIGURE 11. 3 × 3 Nolen matrix with lumped-element couplers and phase shifters (a) Simulated layout. (b) Fabricated photograph [54].

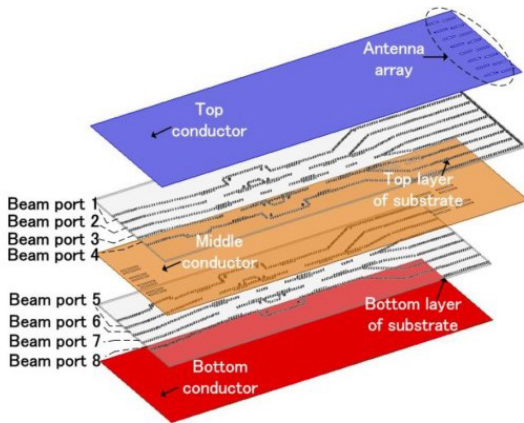

FIGURE 9. Simulated model of the dual-layer 8 × 8 Butler matrix [84].

of a dual-layer SIW 8 × 8 Butler matrix developed in [84] is shown in Fig. 9.

As illustrated above, a dual-layer configuration can help remove some of the crossovers to decrease the losses and to improve the compactness of the BFN layout. Using coplanar waveguide (CPW) multilayer technology is another solution. In [85], a 4 × 4 Butler matrix with the slot-coupled directional coupler using CPW multilayer technology is described to avoid any crossing lines in the matrix. Such design reduces the size of the proposed circuit.

3) LUMPED ELEMENTS CIRCUITS

Miniaturised lumped-element devices, such as coupler and crossover structures, are also popular among researchers as a solution to reduce the size of the feed network in beamforming antenna arrays. For instance, Gandini *et al.* presented in [86] a lumped-element unit cell for designing compact BFNs. This structure is shown in Fig. 10.

Ren *et al.* employed lumped-element couplers to minimise the size of the Nolen matrix, especially for low frequency applications [54]. The simulated layout and fabricated prototype of the proposed 3 × 3 Nolen matrix feeding network are shown in Fig. 11.

4) MINIATURIZED TRANSMISSION LINES

As mentioned above, SIW is a good candidate technology to reduce losses at mm-wave frequencies. However, this typically leads to larger circuit boards, which may compromise

the system integration. For this reason, several alternative transmission lines, derived from SIW technology, such as half-mode substrate integrated waveguide (HMSIW) [87], ridge substrate integrated waveguide (RSIW) [88], folded C-type substrate integrated waveguide (FCSIW) [89], ridged half-mode substrate integrated waveguide (RHMSIW) [44], have been proposed to reduce the circuit dimensions while preserving planar transmission characteristics and compatibility with low-cost PCB processes. Among them, FCSIW has been widely used because it has the lowest loss figure while providing size miniaturization. In [90], a mm-wave multibeam array antenna using FCSIW technology is proposed. A miniaturized 4×4 Butler matrix and a single-branch slot-array are described, where the designs exhibit 40% and 33.2% reduction in occupied surface for the Butler matrix and the whole multibeam array antenna, respectively, in comparison with their standard SIW counterparts, while demonstrating similar RF performance.

Substrate integrated suspended line (SISL) is another promising alternative transmission line technology that has been proposed and applied for both passive and active circuit designs [91], [92], as it features good properties, including low loss, low cost, and high integration. An SISL Butler matrix using patch element and honeycomb concept was proposed in [92]. The feed network is composed of four couplers, two crossovers implemented using patch elements for ease of fabrication and low conductor loss, as well as four phase shifters. The honeycomb concept provides a multicavity structure where every component of the Butler matrix is isolated from each other, so they can be designed and adjusted separately. This makes the system integration more efficient and flexible. Although the developed SISL Butler matrix benefits from self-packaging mechanism, it has a complex circuit because it employs a large number of plated vias, and multilayer substrates are required to create housing for each component. In this regard, perfect magnetic conductor (PMC) packaging is an effective technique for device shielding. In [93], a PMC packaging concept was utilized at mm-wave frequencies, which suppresses the higher order cavity modes, improves insertion losses, and helps in developing packaged microstrip lines (PMSLs) and double-ridge gap waveguide (DRGW) transmission lines.

C. EXTENDING THE FREQUENCY BANDWIDTH

The active impedance of an array changes with scanning angle. The aforementioned circuit type BFNs use a set of power dividers, couplers, crossovers, and phase shifters to form the feed network. As long as each component is wideband with a stable output phase, the circuit type feed network can achieve a wide operating bandwidth in terms of amplitude and phase characteristics. In this regard, several wideband BFNs have been reported using wideband couplers [83], [94], crossovers [79], Wilkinson dividers [95] and Schiffman phase shifters [96].

There are numerous challenges with the design of wideband structures. For example, the use of fixed phase shifters results

in a beam squint with frequency that limits its application. For the directional couplers, which are the critical components in such networks, the conventional branch line coupler has a narrow bandwidth [97]. Afifi *et al.* reported a wideband Butler matrix using ridge gap waveguide technology. The structure presents 21.25% bandwidth, which shows about three times more bandwidth than the reported counterparts [45]. A novel 4×4 Butler matrix with a wide fractional bandwidth of 56.4% and compact size is presented in [98]. The design used a swap in a vertically installed planar structure to implement the quadrature coupler and crossover required by the Butler matrix topology.

In [99], a planar wideband circular polarized (CP) beam steering antenna array with a Butler matrix network is proposed utilizing the rotation technique. This technique is widely used for achieving CP radiation and enhancing the impedance and axial ratio bandwidths [99], [100]. In [101], Zhu *et al.* presented a wideband multibeam antenna array based on a three-beam Butler matrix, while the method is applicable for designing larger beamforming circuits. The BFN comprising wideband quadrature and phase shifters is developed using striplines, and the overall network has 46% fractional bandwidth covering the frequency bands from 1.7 GHz to 2.7 GHz. This structure is shown in Fig. 12.

A broadband Nolen matrix using SIW technology is studied in [53]. Being serial feeding networks, Nolen matrices usually introduce significant phase dispersion in their standard form, thus limiting their effective bandwidth. Generally speaking, the Nolen matrix when compared to its Butler matrix counterpart exhibits narrowband performances due to significant phase dispersion introduced by the unequal electrical paths connecting one input to every output. Therefore, using a more parallel topology for the Nolen matrix balancing electrical paths should produce wider frequency bandwidth performances. In [53], broadband frequency operation is achieved with adequate coupler delay compensation, resulting in a more parallel matrix topology. H-plane couplers with continuous aperture are preferred in the proposed design as opposed to the cross-couplers previously used in the serial configuration. The coupler, phase shifter, and final prototype of this design are shown in Fig. 13. The design achieves excellent results over a 11.7% fractional frequency bandwidth centered at 77 GHz.

Bloss matrices can be designed as a true time-delay network, thereby resolving the bandwidth limitations. In this regard, Lialios *et al.* introduced a mm-wave wideband multilayer Bloss matrix for communications between small cells and base stations or between base stations and the gateway [102]. The structure is shown in Fig. 14. The major disadvantage of Bloss matrices is their low efficiency because of the lossy nature of the matrix.

D. ENABLING MULTI-BAND SYSTEMS

As mobile communication standards evolve from generation to generation, mobile operators have ambitious plans to combine the multiple frequency bands into multibeam base

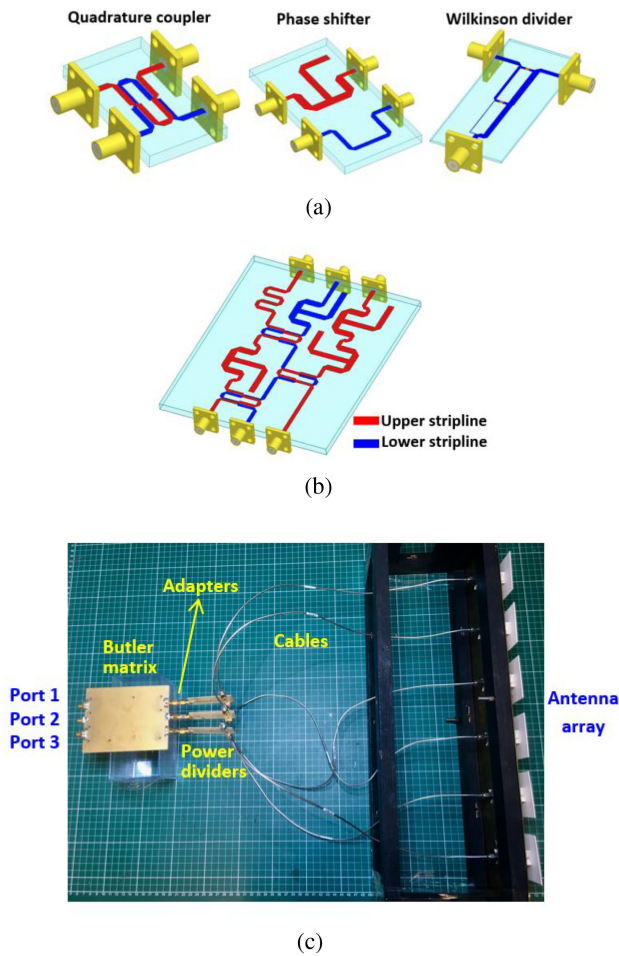

FIGURE 12. (a) 3D model of constructed stripline components used in the design (b) Layout of the three-beam Butler matrix (c) Prototype of the overall structure [101].

stations. To satisfy the demand in multi-band wireless communication systems, several dual-band and multi-band BFNs have been reported.

Dual-band multibeam antenna arrays are commonly built by employing dual-band radiating elements [103], [104] or interleaving radiating elements operating at upper and lower frequency bands [105]. However, one of the major limitations in the realization of dual-band multibeam antenna arrays is the distance between radiating elements in order to keep grating lobes at a reasonable level. Wincza *et al.* presented an approach in which the antenna array consists of N radiating elements operating at the higher frequency range and $N/2$ dual-polarized antenna elements operating at the lower frequency range integrated in a common aperture [106].

The most popular approach when making a dual-band circuit type BFN is to convert all the constituted components of the single band structure into dual-band ones. In this regard, a novel dual-band branch line coupler (BLC) for designing a dual-band Butler matrix was introduced in [107], [108]. The proposed BLC generates a phase difference of $\pm 45^\circ$ and $\pm 135^\circ$ between the outputs ports, which enables it to perform

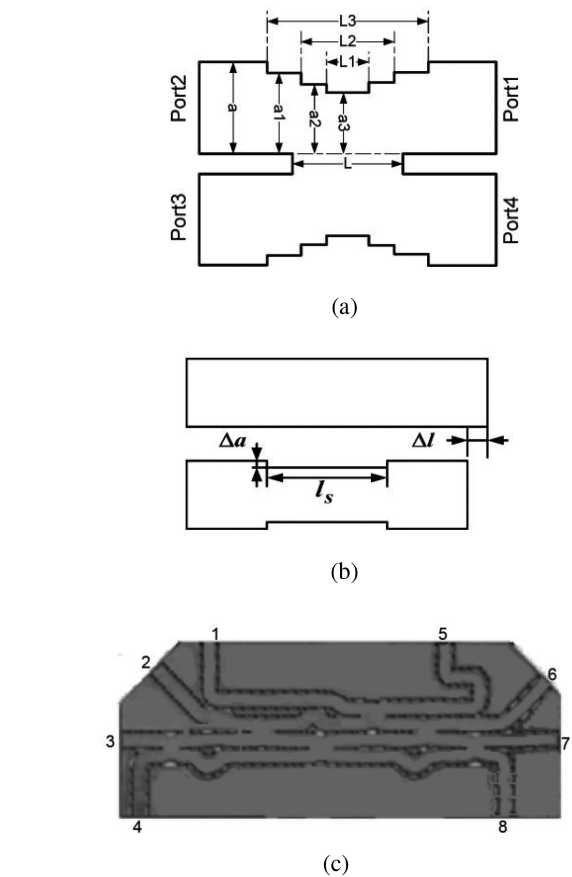

FIGURE 13. (a) Topology of the H-plane short-slot coupler. (b) Topology of unequal with unequal length phase shifter. (c) Manufactured 4×4 Nolen matrix at 77 GHz [53].

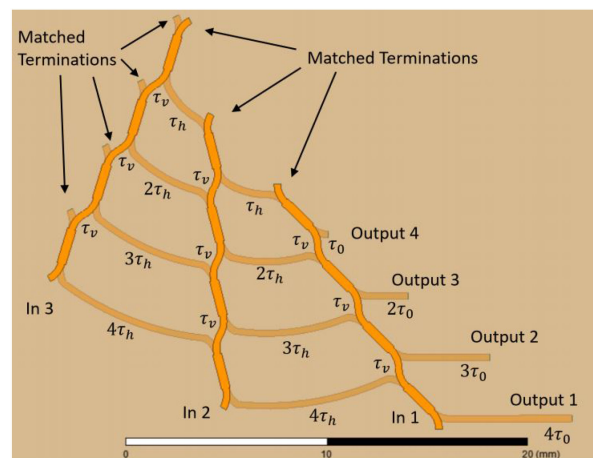
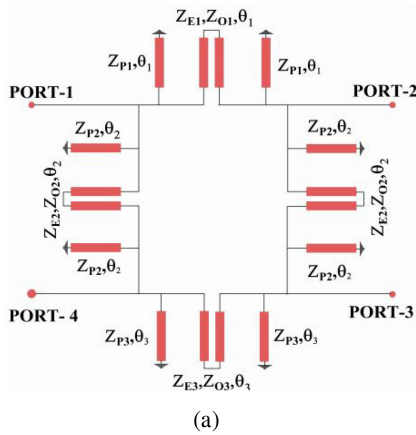
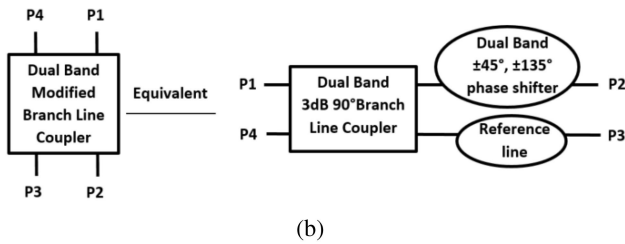

FIGURE 14. Layout of a circular mm-wave Blass matrix [102].

equivalent to the combination of a dual-band $\pm 90^\circ$ BLC and a dual-band $\pm 45^\circ/\pm 135^\circ$ phase shifter. This feature eliminates the requirement of additional phase shifter for the design of Butler matrices. The BLC and basic connections for designing dual-band Butler matrix are shown in Fig. 15.



(a)



(b)

FIGURE 15. (a) Proposed dual-band branch line coupler. (b) Basic connections for designing a dual-band Butler matrix [107].

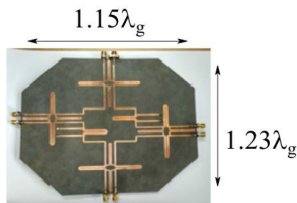
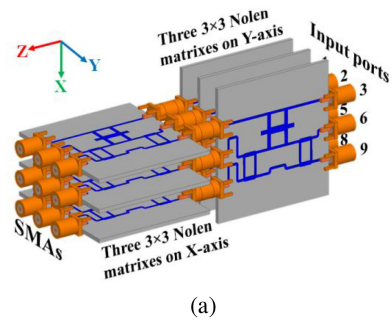

FIGURE 16. Photograph of the fabricated proposed dual-band 4×4 Butler matrix [108].

Another new dual-band 4×4 Butler matrix with dual-band 3 dB quadrature BLC and dual-band $\pm 45^\circ$ phase shifter is reported in [108]. The design is capable of performing dual-band operation with the 2.7 band ratio at 1.0 GHz and 2.5 GHz center frequencies. A photograph of the fabricated 4×4 dual-band Butler matrix realized in microstrip technology is shown in Fig. 16.

E. ENABLING 2D SCANNING

Most reported works on circuit type BFNs have been focused on 1D designs. In practice, many applications would need 2D antenna arrays with a wide scanning range. For example, in cellular multibeam antenna arrays, in order to ease the deployment and to cope with the mast sways of lamp posts and other assumed 5G small cell deployment sites during operation, scanning in 2D is required. However, such scanning capability increases significantly the complexity of the BFN, especially for the cases where a large number of beams are required.



(a)

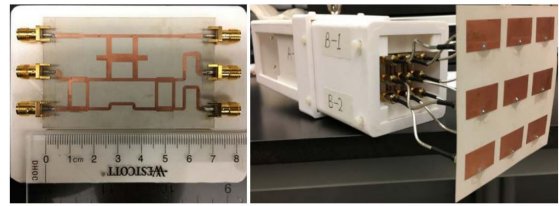

(b)

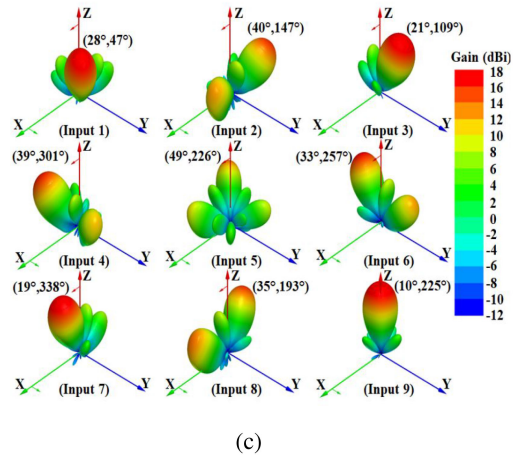

(c)

FIGURE 17. (a) 2D antenna feeding network using six 3×3 Nolen matrices with nine input ports 1–9. (b) Photograph of the fabricated 3×3 Nolen matrix and 2D beamforming phased array. (c) Simulation results of the proposed 2D beamforming phased array, generating nine unique radiation beams with special values on elevation and azimuth (θ, ϕ) when input ports 1–9 are excited [56].

Researchers have been attempting to combine 1D Butler matrices to create BFNs for 2D multibeam antenna arrays. The classic topology for such a BFN consists of two sets of sub-BFNs orthogonally connected to each other; they realize beam forming properties in both the horizontal and vertical planes [109], [110]. A novel 3×3 Nolen matrix for 2D beamforming applications is presented in [56]. The design has been realized in microstrip technology operating at 5.8 GHz. The proposed Nolen matrix employs couplers with arbitrary phase differences and generates relatively flexible phase differences at its output ports. The 2D feeding network structure and the corresponding simulated results of the planar phased array are shown in Fig. 17.

The key challenge in designing 2D multibeam antenna arrays with 1D circuit type BFN is the large size. In this regard,

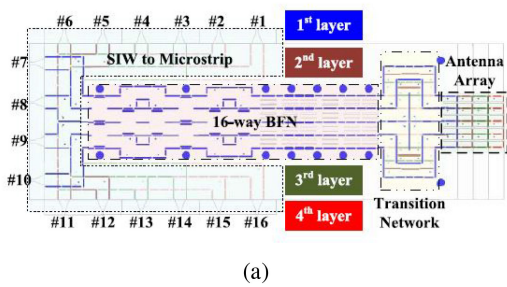

(a)

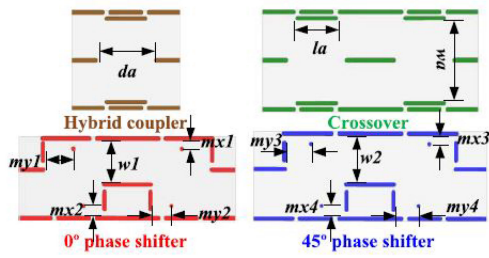

(b)

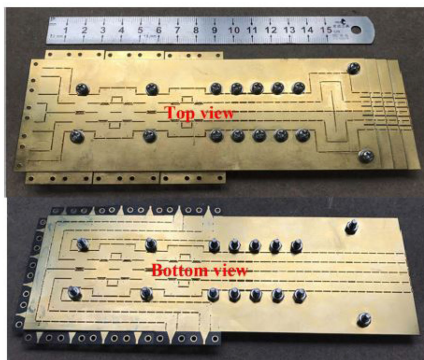

(c)

FIGURE 18. (a) Configuration of the 2D scanning multibeam array antenna. (b) Details of the basic components. (c) Photographs of the fabricated multibeam array antenna [111].

Yang *et al.* [113] proposed a symmetrical 2D BFN at 94 GHz. The network is compactly implemented using two multi-folded Butler matrices and four couplers in LTCC technology, so as to realize eight symmetric beams in 2D with stable gains. Compact 2D multibeam array antenna fed by planar cascaded Butler matrices for mm-wave communication was reported in [114]. Lian *et al.* reported several 2D multibeam antenna arrays in planar and uniplanar structures [111], [115]–[117]. In one of the recent works, a compact mm-wave 2D scanning multibeam antenna array based on a SIW 16-way BFN is proposed. The design covers a reduced area of $3\lambda \times 12\lambda$ and is an attractive candidate for 5G communication systems. This structure is shown in Fig. 18.

Eight-port hybrid couplers and crossovers are proposed to realize uniplanar 2D multibeam BFNs. As an example, they are implemented in a Butler matrix to enable uniplanar 2D BFN in [112]. The proposed crossover can address four path

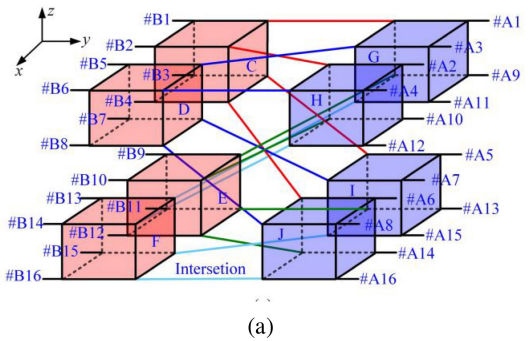

(a)

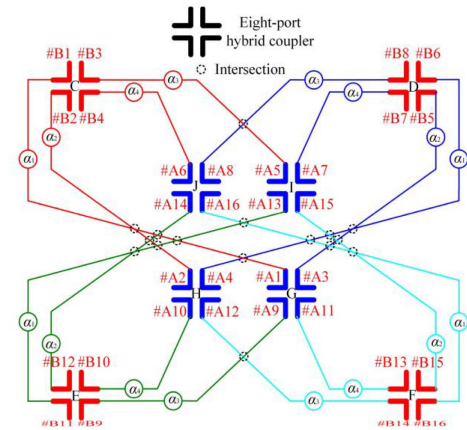

(b)

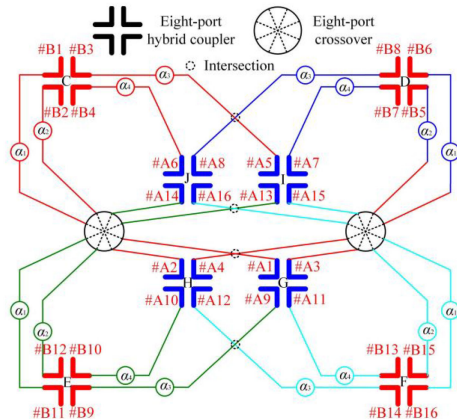

(c)

FIGURE 19. (a) Topology of conventional 16×16 BFN. (b) Proposed topology of uniplanar 16×16 BFN. (c) Proposed topology of 16×16 BFN with eight-port crossover [112].

intersections simultaneously and can reduce the total number of path intersections from 16 to only 4 as shown in Fig. 19. The structure is uniplanar and does not suffer from multilayer design with typical drawbacks such as fabrication complexity, high cost, high losses caused by the transmission between separated layers.

A 2D scanning magneto-electric dipole antenna array fed by a printed ridge gap waveguide (PRGW) Butler matrix is

proposed in [118]. Four scanning beams are created with beam angle direction θ_0 and ϕ_0 calculated as $(35^\circ, -135^\circ)$, $(35^\circ, -45^\circ)$, $(35^\circ, 45^\circ)$, and $(35^\circ, 135^\circ)$ when fed from port 1 to 4, respectively. Wang *et. al* [114] utilized the concept of a 3D-to-planar cascaded Butler matrix topology transition to re-realized a 2D multibeam antenna array at mm-wave frequencies. The beam steering system is compact and creates 16 spatially distributed orthogonal beams scanning a conical space with a maximal cone angle of 77.4° in the elevation plane and 136.8° in the azimuth plane by feeding at different inputs.

F. TRANSMISSION LINES TECHNOLOGIES

Various realization techniques and associated transmission line technologies have been reported for the fabrication of circuit type multiple BFNs. These include microstrips [16], [56], [60], [119], striplines [101], low-temperature co-fired ceramic [120], ridged-waveguides [73], hollow waveguide [121], SIW [53], [115], [122], half-mode SIW [123], ridged half-mode SIW (RHMSIW) [44], coplanar waveguide (CPW) [85], to list a few examples.

Different technologies have their pros and cons. The designs realized with microstrip lines suffer from high dielectric losses, and there are radiation losses especially at high frequencies. However, microstrip technology is cheap and easier to be integrated with other components in RF systems. Besides, with such technology, there is no need for SIW/waveguide-to-microstrip transitions. SIW technology has been developed as a compromise between the low-loss and excellent high-frequency performance of rectangular waveguides, and the integrability of planar transmission lines. However, SIW structures occupy space and have a large size, which opens another door for the development of new techniques to miniaturize their structures.

In [44], Der *et al.* presented an integration of ridge half-mode SIW (RHMSIW) 4×4 Butler matrix with tunable phase shifters fabricated using the same technology to achieve semi-continuous beam steering for 5G applications. This work reported over 70% miniaturization, which shows RHMSIW technology is a promising solution for implementing miniaturized beamforming devices. Fig. 20 shows this structure.

For applications in harsh environment, such as atmospheric satellites and low Earth orbit (LEO) satellites, waveguide is generally the preferred technology, using CNC milling manufacturing. At mm-wave frequencies, the size of the device remains acceptable and the reduced insertion losses are appealing. To further reduce the dimensions of the BFNs in waveguide technology, 2D couplers have been proposed in [125] to combine both stages of beamforming (vertical and horizontal beamforming) in a same structure suitable for planar arrays. Various designs were reported in K-band, including 16×16 and 64×64 Butler matrices [125]–[127]. Most 2D scanning planar arrays using BFNs produce a square lattice of beams. The beam overlap may be improved using a triangular lattice of beams instead. The first demonstration of a 2D Butler matrix generating a triangular lattice of beams was reported

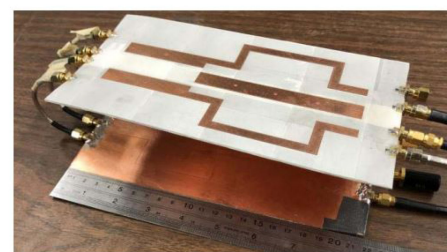
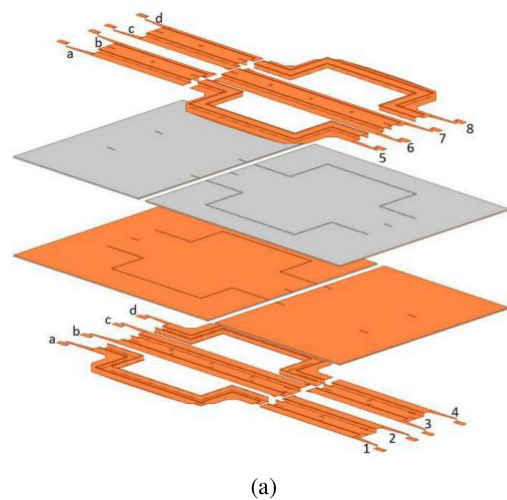

FIGURE 20. (a) Exploded view of the proposed Butler matrix. (b) Test setup of the proposed Butler matrix. The two halves of the matrix are connected via four phase matched SMA cables [44].

recently by Fonseca *et al.* in [124], [128]. Fig. 21 shows the connecting network enabling that interesting property and a picture of the device under test.

V. FUTURE WORK AND CHALLENGES

Based on the application requirements, one or more of the methods listed in this paper may be employed to produce circuit type BFNs suitable for 5G and B5G wireless communication systems. Increasing the bandwidth, improving the scanning range, and reducing the fabrication cost are among some of the challenges to be addressed in future activities. To provide higher system capacity or diversity, current and future wireless communication systems must support dual polarization. Some existing designs can be found in [117], [129]–[134], and they typically require duplication of hardware to achieve dual polarization or a double-sized beamforming network [135]. Simplifying the design and reducing the cost of circuit type BFNs for dual-polarized systems is key to the wireless industry. To this end, a new way of feeding dual-polarized antenna arrays using a single layer network is presented in [136]. However, it works only for a single beam. Significant research is required to advance the state-of-the-art in this field.

Other challenges associated with circuit type BFN based arrays are the limited isolation between beams, which are

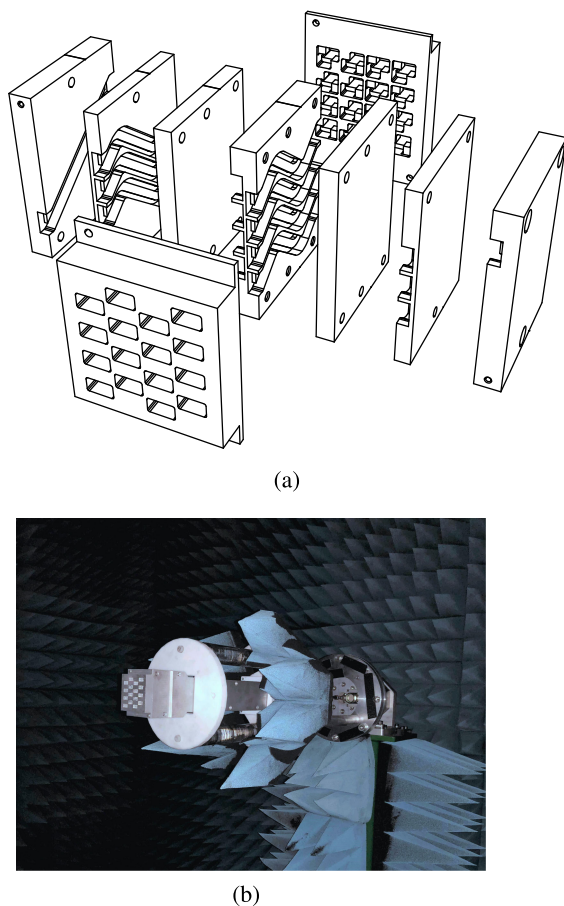

FIGURE 21. (a) CAD view of the connecting network generating a triangular lattice of beams from a 2D Butler matrix. (b) Modified 2D Butler matrix under test [124].

attributed to imperfections in the matrix and variations in the impedances presented by the array radiators. Further challenges are the difference in beam shapes, scan losses and limited scanning angle. These are all important directions for future research.

Another interesting direction of research is the development of hybrid antenna arrays employing a combination of circuit type BFNs and digital array processing techniques, otherwise known as hybrid arrays [137], [138]. Conventional phased arrays typically produce a very small number of simultaneous steered beams using analogue phase shifters, often limited to a single beam capability. MIMO digital signal processing can support dynamic and steerable multiple beams but it requires high power consumption and hardware cost, while analogue multiple beamforming networks produce multiple but fixed beams at low cost. In a cellular network architecture, including also some satellite and more generally non-terrestrial networks, continuous beam steering may not be necessary and the multiple BFNs presented serve as a cost effective technology for sub-dividing the field of view, or service area, into fixed cells. Beam hopping is considered in satellite systems when the number of active beams is lower than the number

of cells constituting the service area, providing dynamic resource allocation [139]–[142]. Future systems are expected to benefit from a hybrid beamforming approach to reduce the number of control points required in a phased array, while providing some level of flexibility, such as a more continuous beam steering or higher pointing direction granularity. This is of interest when the number of beams is much lower than the number of radiating elements and is a promising field of research for cost-effective alternatives to conventional phased array antennas.

Currently, THz spectrum is being considered an important part of the 6G spectrum, especially for achieving extreme data rates over short distances. For these systems, we envisage two antenna technologies to become dominant. One is to employ lenses to achieve high gain without suffering from the losses in transmission lines. The quasi-optical nature of sub-THz and THz waves renders lenses effective in creating high gain antennas. When very high gain is needed, one can combine lenses with digital beamformers to construct a hybrid array [1]. The second promising technology is photonic beamforming networks. In this approach, radio frequency phase shifts are obtained either using a single mode fibre or variable optical delay lines [143], [144].

Generally speaking, new systematic approaches would be needed to create energy and cost optimized solutions for 5G and B5G wireless communications networks.

VI. CONCLUSIONS

5G and B5G wireless communications networks demand cost and energy efficient analogue multibeam antenna arrays. To date, the most promising solution to realize such arrays in the lower part of the frequency spectrum considered for 5G, labelled FR1 and corresponding to below 6 GHz frequency bands, is to employ circuit type BFNs. This paper presented a comprehensive overview of circuit type BFN for multibeam antenna arrays. Different circuit type BFNs were analyzed, particularly focusing on Butler matrices, Blass matrices and Nolen matrices. Various methods to improve the performance of circuit type BFNs were discussed. New research challenges to advance the state of the art in the field were also reviewed.

It is anticipated that novel beamforming techniques and technologies will emerge addressing the specific needs in the mm-wave frequency range, with further miniaturization and integration. It is hoped that this paper will facilitate the discussion and research in this important field.

REFERENCES

- [1] Y. J. Guo and R. W. Ziolkowski, *Advanced Antenna Array Engineering for 6G and Beyond Wireless Communications*. Hoboken, NJ, USA: Wiley, 2021.
- [2] W. Hong *et al.*, “Multibeam antenna technologies for 5G wireless communications,” *IEEE Trans. Antennas Propag.*, vol. 65, no. 12, pp. 6231–6249, Dec. 2017.
- [3] I. Ahmed *et al.*, “A survey on hybrid beamforming techniques in 5G: Architecture and system model perspectives,” *IEEE Commun. Surveys Tuts.*, vol. 20, no. 4, pp. 3060–3097, Oct.-Dec. 2018.

- [4] X. You *et al.*, "Towards 6G wireless communication networks: Vision, enabling technologies, and new paradigm shifts," *Sci. China Inf. Sci.*, vol. 64, no. 1, pp. 1–74, 2021.
- [5] S. Cioni, R. De Gaudenzi, O. Del Rio Herrero, and N. Girault, "On the satellite role in the era of 5G massive machine type communications," *IEEE Netw.*, vol. 32, no. 5, pp. 54–61, Sep./Oct. 2018.
- [6] A. Guidotti *et al.*, "Architectures and key technical challenges for 5G systems incorporating satellites," *IEEE Trans. Veh. Technol.*, vol. 68, no. 3, pp. 2624–2639, Mar. 2019.
- [7] F. Rinaldi *et al.*, "Non-terrestrial networks in 5G beyond: A survey," *IEEE Access*, vol. 8, pp. 165 178–165 200, 2020.
- [8] X. Huang, J. A. Zhang, R. P. Liu, Y. J. Guo, and L. Hanzo, "Airplane-aided integrated networking for 6G wireless: Will it work?," *IEEE Veh. Technol. Mag.*, vol. 14, no. 3, pp. 84–91, Sep. 2019.
- [9] A. Anttonen, P. Ruuska, and M. Kiviranta, "3GPP nonterrestrial networks: A concise review and look ahead," VTT Res. Rep. No VTT-R-00079-19, 2019.
- [10] S. Sun and T. S. Rappaport, "Multi-beam antenna combining for 28 GHz cellular link improvement in urban environments," in *Proc. IEEE Glob. Commun. Conf.*, 2013, pp. 3754–3759.
- [11] R. J. Mailloux, *Phased Array Antenna Handbook*. Norwood, MA, USA: Artech House, 2017.
- [12] H. J. Visser, *Array and Phased Array Antenna Basics*, vol. 2005. New York, NY, USA: Wiley, 2005.
- [13] J. Butler and R. Lowe, "Beam-forming matrix simplifies design of electronically scanned antenna," *Electron. Des.*, vol. 9, pp. 170–173, 1961.
- [14] H. Moody, "The systematic design of the Butler matrix," *IEEE Trans. Antennas Propag.*, vol. 12, no. 6, pp. 786–788, 1964.
- [15] J. Nolen, "Synthesis of multiple beam networks for arbitrary illuminations," Ph.D. dissertation, Radio Div., Bendix Corp., Baltimore, MD, USA, 1965.
- [16] N. J. G. Fonseca, "Printed S-band 4x4 Nolen matrix for multiple beam antenna applications," *IEEE Trans. Antennas Propag.*, vol. 57, no. 6, pp. 1673–1678, Jun. 2009.
- [17] Y. J. Guo and B. Jones, "Base station antennas," in *Antenna Engineering Handbook*, J. Volakis ed. New York, NY, USA: McGraw-Hill 2018, ch. 10.
- [18] W. Roh *et al.*, "Millimeter-wave beamforming as an enabling technology for 5G cellular communications: Theoretical feasibility and prototype results," *IEEE Commun. Mag.*, vol. 52, no. 2, pp. 106–113, Feb. 2014.
- [19] N. J. G. Fonseca, "Discussion on reciprocity, unitary matrix and lossless multiple beam forming networks," *Int. J. Antennas Propag.*, vol. 2015, no. 946289, pp. 1–9, 2015.
- [20] S. Stein, "On cross coupling in multiple-beam antennas," *IRE Trans. Antennas Propag.*, vol. 10, no. 5, pp. 548–557, 1962.
- [21] W. White, "Pattern limitations in multiple-beam antennas," *IRE Trans. Antennas Propag.*, vol. 10, no. 4, pp. 430–436, 1962.
- [22] J. Blass, "Multidirectional antenna - A new approach to stacked beams," *Proc. IRE*, vol. 48, no. 3, pp. 402–402, 1960.
- [23] N. J. G. Fonseca, A. Ali, and H. Aubert, "Cancellation of beam squint with frequency in serial beamforming network-fed linear array antennas," *IEEE Antennas Propag. Mag.*, vol. 54, no. 1, pp. 32–39, Feb. 2012.
- [24] S. Mosca, F. Bilotti, A. Toscano, and L. Vegni, "A novel design method for Blass matrix beam-forming networks," *IEEE Trans. Antennas Propag.*, vol. 50, no. 2, pp. 225–232, Feb. 2002.
- [25] W. R. Jones and E. C. DuFort, "On the design of optimum dual-series feed networks," *IEEE Trans. Microw. Theory Techn.*, vol. 19, no. 5, pp. 451–458, May 1971.
- [26] C. Tsokos *et al.*, "Analysis of a multibeam optical beamforming network based on Blass matrix architecture," *J. Lightw. Technol.*, vol. 36, no. 16, pp. 3354–3372, 2018.
- [27] C. Tsokos *et al.*, "Optical beamforming networks supporting multi-beam and multicast operation," in *Proc. 22nd Int. Conf. Transparent Opt. Netw.*, 2020, pp. 1–5.
- [28] J. Shelton and K. Kelleher, "Multiple beams from linear arrays," *IRE Trans. Antennas Propag.*, vol. 9, no. 2, pp. 154–161, Mar. 1961.
- [29] J. Allen, "A theoretical limitation on the formation of lossless multiple beams in linear arrays," *IRE Trans. Antennas Propag.*, vol. 9, no. 4, pp. 350–352, 1961.
- [30] W. P. Delaney, "An RF multiple beam-forming technique," *IRE Trans. Mil. Electron.*, no. 2, pp. 179–186, 1962.
- [31] J. W. Cooley, P. A. W. Lewis, and P. D. Welch, "Historical notes on the fast Fourier transform," *Proc. IEEE*, vol. 55, no. 10, pp. 1675–1677, Oct. 1967.
- [32] J. P. Shelton, "Fast Fourier transforms and Butler matrices," *Proc. IEEE*, vol. 56, no. 3, pp. 350–350, Mar. 1968.
- [33] W. Nester, "The fast Fourier transform and the Butler matrix," *IEEE Trans. Antennas Propag.*, vol. 16, no. 3, pp. 360–360, May 1968.
- [34] J. P. Shelton, "Multibeam planar arrays," *Proc. IEEE*, vol. 56, no. 11, pp. 1818–1821, Nov. 1968.
- [35] P. Angeletti, "Multiple beams from planar arrays," *IEEE Trans. Antennas Propag.*, vol. 62, no. 4, pp. 1750–1761, Apr. 2014.
- [36] W. Kahn and H. Kurss, "The uniqueness of the lossless feed network for a multibeam array," *IRE Trans. Antennas Propag.*, vol. 10, no. 1, pp. 100–101, 1962.
- [37] P. Angeletti and M. Lisi, "Multimode beamforming networks for space applications," *IEEE Antennas Propag. Mag.*, vol. 56, no. 1, pp. 62–78, Feb. 2014.
- [38] S. P. Skobelev, "Methods of constructing optimum phased-array antennas for limited field of view," *IEEE Antennas Propag. Mag.*, vol. 40, no. 2, pp. 39–50, Apr. 1998.
- [39] D. Betancourt and C. del RioBocio, "A novel methodology to feed phased array antennas," *IEEE Trans. Antennas Propag.*, vol. 55, no. 9, pp. 2489–2494, Sep. 2007.
- [40] N. Ferrando and N. J. G. Fonseca, "Investigations on the efficiency of array fed coherently radiating periodic structure beam forming networks," *IEEE Trans. Antennas Propag.*, vol. 59, no. 2, pp. 493–502, Feb. 2011.
- [41] N. J. G. Fonseca, "Discussion on tapered amplitude multiple beam forming networks for array antenna design," in *Proc. Int. Symp. Antennas Prop.*, Jeju, Korea, Oct. 2011, pp. 1–4.
- [42] N. J. G. Fonseca, "Design and implementation of a closed cylindrical BFN-fed circular array antenna for multiple-beam coverage in azimuth," *IEEE Trans. Antennas Propag.*, vol. 60, no. 2, pp. 863–869, Feb. 2012.
- [43] H. E. A. Laue and W. P. du Plessis, "A checkered network for implementing arbitrary overlapped feed networks," *IEEE Trans. Microw. Theory Techn.*, vol. 67, no. 11, pp. 4632–4640, Nov. 2019.
- [44] E. T. Der, T. R. Jones, and M. Daneshmand, "Miniaturized 4 × 4 Butler matrix and tunable phase shifter using ridged half-mode substrate integrated waveguide," *IEEE Trans. Microw. Theory Techn.*, vol. 68, no. 8, pp. 3379–3388, Aug. 2020.
- [45] I. Afifi and A.-R. Sebak, "Wideband 4 × 4 Butler matrix in the printed ridge gap waveguide technology for millimeter wave applications," *IEEE Trans. Antennas Propag.*, vol. 68, no. 11, pp. 7670–7675, Nov. 2020.
- [46] H. Ren *et al.*, "A novel design of 4 × 4 Butler matrix with relatively flexible phase differences," *IEEE Antennas Wireless Propag. Lett.*, vol. 15, pp. 1277–1280, Dec. 2015.
- [47] Q. Wu, J. Hirokawa, J. Yin, C. Yu, H. Wang, and W. Hong, "Millimeter-wave multibeam endfire dual-circularly polarized antenna array for 5G wireless applications," *IEEE Trans. Antennas Propag.*, vol. 66, no. 9, pp. 4930–4935, Sep. 2018.
- [48] W. C. Cummings, "Multiple beam forming networks," MIT Lincoln Lab., Lexington, MA, USA, Tech. Note 1978-9, Apr. 1978.
- [49] N. J. G. Fonseca, "An investigation of Blass and Nolen matrices," CNES Toulouse Space Center, Toulouse, France, Tech. Note 152, Nov. 2007.
- [50] N. J. G. Fonseca, "Study and design of a S-band 4 × 4 Nolen matrix for satellite digital multimedia broadcasting applications," in *Proc. 12th Int. Symp. Antenna Technol. Appl. Electromagn. (ANTEM URSI/CNC)*, Montréal, QC, Canada, Jul. 2006, pp. 481–484.
- [51] A. Ali *et al.*, "Novel two-layer 4 × 4 SIW Nolen matrix for multi-beam antenna application in Ku-band," in *Proc. 3rd Eur. Conf. Antennas Propag.*, Berlin, Germany, Mar. 2009, pp. 241–243.
- [52] T. Djerafi, N. J. G. Fonseca, and K. Wu, "Planar Ku-band 4 × 4 Nolen matrix in SIW technology," *IEEE Trans. Microw. Theory Techn.*, vol. 58, no. 2, pp. 259–266, Jan. 2010.
- [53] T. Djerafi, N. J. G. Fonseca, and K. Wu, "Broadband substrate integrated waveguide 4 × 4 Nolen matrix based on coupler delay compensation," *IEEE Trans. Microw. Theory Techn.*, vol. 59, no. 7, pp. 1740–1745, Jul. 2011.
- [54] H. Ren, H. Zhang, and B. Arigong, "Ultra-compact 3 × 3 Nolen matrix beamforming network," *IET Microw. Antennas Propag.*, vol. 14, no. 3, pp. 143–148, 2020.

- [55] P. Li, H. Ren, and B. Arigong, "A symmetric beam-phased array fed by a Nolen matrix using 180° couplers," *IEEE Microw. Wireless Compon. Lett.*, vol. 30, no. 4, pp. 387–390, Apr. 2020.
- [56] H. Ren, H. Zhang, Y. Jin, Y. Gu, and B. Arigong, "A novel 2D 3 × 3 Nolen matrix for 2D beamforming applications," *IEEE Trans. Microw. Theory Techn.*, vol. 67, no. 11, pp. 4622–4631, Nov. 2019.
- [57] K. Wincza, S. Gruszczynski, and K. Sachse, "Reduced sidelobe four-beam antenna array fed by modified Butler matrix," *Electron. Lett.*, vol. 42, no. 9, pp. 508–509, 2006.
- [58] N. J. G. Fonseca and N. Ferrando, "Nolen matrix with tapered amplitude law for linear arrays with reduced side lobe level," in *Proc. 4th Eur. Conf. Antennas Propag.*, Barcelona, Spain, Apr. 2010, pp. 1–5.
- [59] S. Gruszczynski, K. Wincza, and K. Sachse, "Reduced sidelobe four-beam N -element antenna arrays fed by 4 × N Butler matrices," *IEEE Antennas Wireless Propag. Lett.*, vol. 5, pp. 430–434, May 2006.
- [60] M. Ansari, H. Zhu, N. Shariati, and Y. J. Guo, "Compact planar beamforming array with endfire radiating elements for 5G applications," *IEEE Trans. Antennas Propag.*, vol. 67, no. 11, pp. 6859–6869, Nov. 2019.
- [61] S. Trinh-Van, J. M. Lee, Y. Yang, K. Lee, and K. C. Hwang, "A sidelobe-reduced, four-beam array antenna fed by a modified 4 × 4 Butler matrix for 5G applications," *IEEE Trans. Antennas Propag.*, vol. 67, no. 7, pp. 4528–4536, Jul. 2019.
- [62] D. M. Pozar and B. Kaufman, "Design considerations for low sidelobe microstrip arrays," *IEEE Trans. Antennas Propag.*, vol. 38, no. 8, pp. 1176–1185, Aug. 1990.
- [63] J. Shelton, "Reduced sidelobes for Butler-matrix-fed linear arrays," *IEEE Trans. Antennas Propag.*, vol. 17, no. 5, pp. 645–647, Sep. 1969.
- [64] W.-R. Li et al., "Switched-beam antenna based on modified Butler matrix with low sidelobe level," *Electron. Lett.*, vol. 40, no. 5, pp. 290–292, 2004.
- [65] J. Hirokawa, K. Morimoto, and M. Ando, "Beam-switching single-layer post-wall waveguide slot array controlling crossover & sidelobes," in *Proc. 2nd Eur. Conf. Antennas Propag.*, Edinburgh, U.K., Nov. 2007.
- [66] K. Wincza et al., "Reduced sidelobe multibeam antenna array with broadside beam fed by 4 × 8 Butler matrix," in *Proc. Int. Symp. Antennas Propag.*, Hobart, Australia, Nov. 2015, pp. 1–3.
- [67] B. Strait, "Antenna arrays with partially tapered amplitudes," *IEEE Trans. Antennas Propag.*, vol. 15, no. 5, pp. 611–617, Sep. 1967.
- [68] F. E. Fakoukakis, G. A. Kyriacou, and J. N. Sahalos, "On the design of Butler-like type matrices for low SLL multibeam antennas," in *Proc. 6th Eur. Conf. Antennas Propag.*, Prague, Czech Republic, Mar. 2012, pp. 2604–2608.
- [69] A. Fragola, M. Orefice, and M. Pirola, "A modified Butler matrix for tapered excitation of scanned arrays," in *IEEE Antennas Propag. Soc. Int. Symp. Dig.*, vol. 4, 2001, pp. 784–787.
- [70] E. DuFort, "Optimum low sidelobe high crossover multiple beam antennas," *IEEE Trans. Antennas Propag.*, vol. 33, no. 9, pp. 946–954, Sep. 1985.
- [71] H. Nasserli, M. Bemani, and A. Ghaffarlou, "A new method for arbitrary amplitude distribution generation 4 × 8 in Butler matrix," *IEEE Microw. Wireless Compon. Lett.*, vol. 30, no. 3, pp. 249–252, Mar. 2020.
- [72] K. Wincza, S. Gruszczynski, and K. Sachse, "Conformal four-beam antenna arrays with reduced sidelobes," *Electron. Lett.*, vol. 44, no. 3, pp. 174–175, 2008.
- [73] K. Tekkouk, J. Hirokawa, R. Sauleau, M. Ettore, M. Sano, and M. Ando, "Dual-layer ridged waveguide slot array fed by a Butler matrix with sidelobe control in the 60-GHz band," *IEEE Trans. Antennas Propag.*, vol. 63, no. 9, pp. 3857–3867, Sep. 2015.
- [74] F. Doucet et al., "Shaped continuous parallel plate delay lens with enhanced scanning performance," *IEEE Trans. Antennas Propag.*, vol. 67, no. 11, pp. 6695–6704, Nov. 2019.
- [75] K. Wu, M. Bozzi, and N. J. G. Fonseca, "Substrate integrated transmission lines: Review and applications," *IEEE J. Microwaves*, vol. 1, no. 1, pp. 345–363, Jan. 2021.
- [76] H. Hayashi, D. A. Hitko, and C. G. Sodini, "Four-element planar Butler matrix using half-wavelength open stubs," *IEEE Microw. Wireless Compon. Lett.*, vol. 12, no. 3, pp. 73–75, Mar. 2002.
- [77] C. Dall'Omo et al., "Design and realization of a 4 × 4 microstrip Butler matrix without any crossing in millimeter waves," *Microw. Opt. Technol. Lett.*, vol. 38, no. 6, pp. 462–465, 2003.
- [78] G. Tian, J. Yang, and W. Wu, "A novel compact Butler matrix without phase shifter," *IEEE Microw. Wireless Compon. Lett.*, vol. 24, no. 5, pp. 306–308, May 2014.
- [79] H. Nachouane et al., "Broadband 4 × 4 Butler matrix using wideband 90° hybrid couplers and crossovers for beamforming networks," in *Proc. Int. Conf. Multimedia Comput. Syst.*, 2014, pp. 1444–1448.
- [80] T. Djerafi and K. Wu, "A low-cost wideband 77-GHz planar Butler matrix in SIW technology," *IEEE Trans. Antennas Propag.*, vol. 60, no. 10, pp. 4949–4954, Oct. 2012.
- [81] Y. Cao, K. Chin, W. Che, W. Yang, and E. S. Li, "A compact 38 GHz multibeam antenna array with multifolded Butler matrix for 5G applications," *IEEE Antennas Wireless Propag. Lett.*, vol. 16, pp. 2996–2999, Sep. 2017.
- [82] A. A. M. Ali, N. J. G. Fonseca, F. Coccetti, and H. Aubert, "Design and implementation of two-layer compact wideband Butler matrices in SIW technology for Ku-band applications," *IEEE Trans. Antennas Propag.*, vol. 59, no. 2, pp. 503–512, Feb. 2010.
- [83] S. Karamzadeh et al., "Compact and broadband 4 × 4 SIW Butler matrix with phase and magnitude error reduction," *IEEE Microw. Wireless Compon. Lett.*, vol. 25, no. 12, pp. 772–774, Nov. 2015.
- [84] L.-H. Zhong, Y. Ban, J. Lian, Q. Yang, J. Guo, and Z. Yu, "Miniaturized SIW multibeam antenna array fed by dual-layer 8 × 8 Butler matrix," *IEEE Antennas Wireless Propag. Lett.*, vol. 16, pp. 3018–3021, Oct. 2017.
- [85] M. Nedil, T. A. Denidni, and L. Talbi, "Novel Butler matrix using CPW multilayer technology," *IEEE Trans. Microw. Theory Techn.*, vol. 54, no. 1, pp. 499–507, Jan. 2006.
- [86] E. Gandini, M. Ettore, R. Sauleau, and A. Grbic, "A lumped-element unit cell for beam-forming networks and its application to a miniaturized Butler matrix," *IEEE Trans. Microw. Theory Techn.*, vol. 61, no. 4, pp. 1477–1487, Apr. 2013.
- [87] Q. Lai, C. Fumeaux, W. Hong, and R. Vahldieck, "Characterization of the propagation properties of the half-mode substrate integrated waveguide," *IEEE Trans. Microw. Theory Techn.*, vol. 57, no. 8, pp. 1996–2004, Aug. 2009.
- [88] Y. Ding and K. Wu, "A 4 × 4 ridge substrate integrated waveguide (rsiw) slot array antenna," *IEEE Antennas Wireless Propag. Lett.*, vol. 8, pp. 561–564, Apr. 2009.
- [89] N. Nguyen-Trong, T. Kaufmann, L. Hall, and C. Fumeaux, "Variational analysis of folded substrate-integrated waveguides," *IEEE Microw. Wireless Compon. Lett.*, vol. 25, no. 6, pp. 352–354, Jun. 2015.
- [90] Q. Sun, Y. Ban, J. Lian, Y. Liu, and Z. Nie, "Millimeter-wave multi-beam antenna based on folded c-type SIW," *IEEE Trans. Antennas Propag.*, vol. 68, no. 5, pp. 3465–3476, May 2020.
- [91] Y. Wang, K. Ma, N. Yan, and L. Li, "A slow-wave rat-race coupler using substrate integrated suspended line technology," *IEEE Trans. Compon. Packag. Manuf. Technol.*, vol. 7, no. 4, pp. 630–636, Apr. 2017.
- [92] Y. Wang, K. Ma, and Z. Jian, "A low-loss Butler matrix using patch element and honeycomb concept on SISL platform," *IEEE Trans. Microw. Theory Techn.*, vol. 66, no. 8, pp. 3622–3631, Aug. 2018.
- [93] N. Ashraf, A.-R. Sebak, and A. A. Kishk, "PMC packaged single-substrate 4 × 4 Butler matrix and double-ridge gap waveguide horn antenna array for multibeam applications," *IEEE Trans. Microw. Theory Techn.*, vol. 69, no. 1, pp. 248–261, Jan. 2021.
- [94] K. Wincza, S. Gruszczynski, and K. Sachse, "Broadband planar fully integrated 8 × 8 Butler matrix using coupled-line directional couplers," *IEEE Trans. Microw. Theory Techn.*, vol. 59, no. 10, pp. 2441–2446, Sep. 2011.
- [95] H. Nachouane et al., "Wideband 3 × 4 Butler matrix using Wilkinson divider for MIMO applications," in *Proc. Int. Conf. Next Gener. Netw. Serv.*, 2014, pp. 101–105.
- [96] K. Wincza and S. Gruszczynski, "Broadband integrated 8 × 8 Butler matrix utilizing quadrature couplers and Schiffman phase shifters for multibeam antennas with broadside beam," *IEEE Trans. Microw. Theory Techn.*, vol. 64, no. 8, pp. 2596–2604, Aug. 2016.
- [97] D. M. Pozar, *Microwave Engineering*. Hoboken, NJ, USA: Wiley, 2011.
- [98] Q. P. Chen, Z. Qamar, S. Y. Zheng, Y. Long, and D. Ho, "Design of a compact wideband Butler matrix using vertically installed planar structure," *IEEE Trans. Compon. Packag. Manuf. Technol.*, vol. 8, no. 8, pp. 1420–1430, Aug. 2018.

- [99] C. Liu, S. Xiao, Y. Guo, M. Tang, Y. Bai, and B. Wang, "Circularly polarized beam-steering antenna array with Butler matrix network," *IEEE Antennas Wireless Propag. Lett.*, vol. 10, pp. 1278–1281, Nov. 2011.
- [100] J. Huang, "A technique for an array to generate circular polarization with linearly polarized elements," *IEEE Trans. Antennas Propag.*, vol. 34, no. 9, pp. 1113–1124, Sep. 1986.
- [101] H. Zhu, H. Sun, B. Jones, C. Ding, and Y. J. Guo, "Wideband dual-polarized multiple beam-forming antenna arrays," *IEEE Trans. Antennas Propag.*, vol. 67, no. 3, pp. 1590–1604, Mar. 2019.
- [102] D. I. Lialios *et al.*, "Design of true time delay millimeter wave beamformers for 5G multibeam phased arrays," *Electronics*, vol. 9, no. 8, 2020, Art no. 1331.
- [103] H. Ren *et al.*, "Compact phased array antenna system based on dual-band operations," *Microw. Opt. Technol. Lett.*, vol. 56, no. 6, pp. 1391–1396, 2014.
- [104] J. Lee and K. Chang, "Dual-band switched beam array fed by dual-band Butler matrix," *Electron. Lett.*, vol. 47, no. 21, pp. 1164–1165, 2011.
- [105] N. Amiri and K. Forooghi, "Dual-band and dual-polarized microstrip array antenna for GSM900/DCS1800 MHz base stations," in *Proc. IEEE Antennas Propag. Soc. Int. Symp.*, 2006, pp. 4439–4442.
- [106] K. Wincza, K. Staszek, I. Slomian, and S. Gruszczynski, "Scalable multibeam antenna arrays fed by dual-band modified Butler matrices," *IEEE Trans. Antennas Propag.*, vol. 64, no. 4, pp. 1287–1297, Apr. 2016.
- [107] A. M. Zaidi, B. K. Kanaujia, M. T. Beg, J. Kishor, and K. Rambabu, "A novel dual-band branch line coupler for dual-band Butler matrix," *IEEE Trans. Circuits Syst. II, Exp. Briefs*, vol. 66, no. 12, pp. 1987–1991, Dec. 2019.
- [108] A. M. Zaidi, "A new dual band 4×4 Butler matrix with dual band 3 dB quadrature branch line coupler and dual band 45° phase shifter," *AEU-Int. J. Electron. Commun.*, vol. 99, pp. 215–225, 2019.
- [109] D.-H. Kim, J. Hirokawa, and M. Ando, "Design of waveguide short-slot two-plane couplers for one-body 2D beam-switching Butler matrix application," *IEEE Trans. Microw. Theory Techn.*, vol. 64, no. 3, pp. 776–784, Mar. 2016.
- [110] K. Ding and A. A. Kishk, "2D Butler matrix and phase-shifter group," *IEEE Trans. Microw. Theory Techn.*, vol. 66, no. 12, pp. 5554–5562, Dec. 2018.
- [111] J.-W. Lian, Y. Ban, Q. Yang, B. Fu, Z. Yu, and L. Sun, "Planar millimeter-wave 2D beam-scanning multibeam array antenna fed by compact SIW beam-forming network," *IEEE Trans. Antennas Propag.*, vol. 66, no. 3, pp. 1299–1310, Mar. 2018.
- [112] J.-W. Lian, Y. Ban, Q. Yang, B. Fu, Z. Yu, and L. Sun, "Uniplanar beam-forming network employing eight-port hybrid couplers and crossovers for 2D multibeam array antennas," *IEEE Trans. Microw. Theory Techn.*, vol. 68, no. 11, pp. 4706–4718, Nov. 2020.
- [113] W. Yang *et al.*, "94-GHz compact 2D multibeam LTCC antenna based on multifolded SIW beam-forming network," *IEEE Trans. Antennas Propag.*, vol. 65, no. 8, pp. 4328–4333, Aug. 2017.
- [114] X. Wang, Y. Yang, W. Che, C. Fan, and Q. Xue, "Compact 2D multibeam array antenna fed by planar cascaded Butler matrix for millimeter-wave communication," *IEEE Antennas Wireless Propag. Lett.*, vol. 18, no. 10, pp. 2056–2060, 2019.
- [115] J.-W. Lian, Y. Ban, J. Zhu, K. Kang, and Z. Nie, "Compact 2D scanning multibeam array utilizing the SIW three-way couplers at 28 GHz," *IEEE Antennas Wireless Propag. Lett.*, vol. 17, no. 10, pp. 1915–1919, Oct. 2018.
- [116] J.-W. Lian, Y. Ban, J. Zhu, K. Kang, and Z. Nie, "Planar 2D scanning SIW multibeam array with low sidelobe level for millimeter-wave applications," *IEEE Trans. Antennas Propag.*, vol. 67, no. 7, pp. 4570–4578, Jul. 2019.
- [117] J.-W. Lian, Y. Ban, J. Zhu, K. Kang, and Z. Nie, "Uniplanar high-gain 2D scanning leaky-wave multibeam array antenna at fixed frequency," *IEEE Trans. Antennas Propag.*, vol. 68, no. 7, pp. 5257–5268, Jul. 2020.
- [118] M. M. M. Ali and A.-R. Sebak, "2D scanning magnetoelectric dipole antenna array fed by RGW Butler matrix," *IEEE Trans. Antennas Propag.*, vol. 66, no. 11, pp. 6313–6321, Nov. 2018.
- [119] W. F. Moulder, W. Khalil, and J. L. Volakis, "60-GHz two-dimensionally scanning array employing wideband planar switched beam network," *IEEE Antennas Wireless Propag. Lett.*, vol. 9, pp. 818–821, Aug. 2010.
- [120] Y. J. Cheng, X. Y. Bao, and Y. X. Guo, "60-GHz LTCC miniaturized substrate integrated multibeam array antenna with multiple polarizations," *IEEE Trans. Antennas Propag.*, vol. 61, no. 12, pp. 5958–5967, Dec. 2013.
- [121] S. Yamamoto, J. Hirokawa, and M. Ando, "A single-layer hollow-waveguide 8-way Butler matrix," in *Proc. IEEE Antennas Propag. Soc. Int. Symp.*, vol. 1A, 2005, pp. 647–650.
- [122] Q. Yang, Y. Ban, K. Kang, C. Sim, and G. Wu, "SIW multibeam array for 5G mobile devices," *IEEE Access*, vol. 4, pp. 2788–2796, 2016.
- [123] X. Jun-Feng, "A novel Butler matrix based on half-mode substrate integrated waveguide technology," *J. Microw.*, vol. 24, no. 3, pp. 5–9, Nov. 2008.
- [124] N. J. G. Fonseca *et al.*, "Connecting networks for 2D Butler matrices generating a triangular lattice of beams," *IEEE J. Microwaves*, vol. 1, no. 2, pp. 646–658, Apr. 2021.
- [125] D.-H. Kim, J. Hirokawa, and M. Ando, "Design of waveguide short-slot 2-plane couplers for one-body 2D beam-switching Butler matrix application," *IEEE Trans. Microw. Theory Techn.*, vol. 64, no. 3, pp. 776–784, Mar. 2016.
- [126] J. Hirokawa, D. Kim, M. Wakasa, Y. Sunaguchi, T. Tomura, and K. Nishimori, "Measurements of a 64×64 -way one-body two-dimensional beam-switching hollow-waveguide Butler matrix," in *Proc. Eur. Microw. Week*, Madrid, Spain, Sep. 2018, pp. 125–128.
- [127] T. Tomura *et al.*, "A 20-GHz-band 64×64 hollow waveguide two-dimensional Butler matrix," *IEEE Access*, vol. 7, pp. 164 080–164 088, Nov. 2019.
- [128] N. J. G. Fonseca, S.-A. Gomanne, and J. Hirokawa, "Connecting networks for 2D Butler matrices with improved aggregate gain," in *Proc. Int. Symp. Antennas Propag.*, no. 2E4.2, Osaka, Japan, Jan. 2021, pp. 285–286.
- [129] H. Xin *et al.*, "A two-dimensional millimeter wave phase scanned lens utilizing analog electromagnetic crystal (EMXT) waveguide phase shifters," *IEEE Trans. Antennas Propag.*, vol. 53, no. 1, pp. 151–159, Jan. 2005.
- [130] O. Quevedo-Teruel, M. Ebrahimpouri, and F. Ghasemifard, "Lens antennas for 5G communications systems," *IEEE Commun. Mag.*, vol. 56, no. 7, pp. 36–41, Jul. 2018.
- [131] Q. Liao, N. J. G. Fonseca, and O. Quevedo-Teruel, "Compact multibeam fully metallic geodesic Luneburg lens antenna based on non-euclidean transformation optics," *IEEE Trans. Antennas Propag.*, vol. 66, no. 12, pp. 7383–7388, Dec. 2018.
- [132] Y. Geng, J. Wang, Y. Li, Z. Li, M. Chen, and Z. Zhang, "Radiation pattern-reconfigurable leaky-wave antenna for fixed-frequency beam steering based on substrate-integrated waveguide," *IEEE Antennas Wireless Propag. Lett.*, vol. 18, no. 2, pp. 387–391, Feb. 2019.
- [133] N. J. G. Fonseca, Q. Liao, and O. Quevedo-Teruel, "Equivalent planar lens ray-tracing model to design modulated geodesic lenses using non-euclidean transformation optics," *IEEE Trans. Antennas Propag.*, vol. 68, no. 5, pp. 3410–3422, May 2020.
- [134] N. J. G. Fonseca, Q. Liao, and O. Quevedo-Teruel, "Compact parallel-plate waveguide half-Luneburg geodesic lens in the K-band," *IET Microw. Antennas Propag.*, vol. 15, no. 2, pp. 123–130, Feb. 2021.
- [135] Y. Park, J. Bang, Y. Kim, and J. Choi, "Beam-steerable dual-circular polarized 60 GHz patch antenna array with 8×8 Butler matrix," in *Proc. Int. Symp. Antennas Propag.*, 2019, pp. 1–3.
- [136] A. Li and K.-M. Luk, "Single-layer wideband end-fire dual-polarized antenna array for device-to-device communication in 5G wireless systems," *IEEE Trans. Veh. Technol.*, vol. 69, no. 5, pp. 5142–5150, May 2020.
- [137] S. Han *et al.*, "Large-scale antenna systems with hybrid analog and digital beamforming for millimeter wave 5G," *IEEE Commun. Mag.*, vol. 53, no. 1, pp. 186–194, Jan. 2015.
- [138] X. Huang, Y. J. Guo, and J. D. Bunton, "A hybrid adaptive antenna array," *IEEE Trans. Wireless Commun.*, vol. 9, no. 5, pp. 1770–1779, May 2010.
- [139] N. J. G. Fonseca and J. Sombrin, "Multi-beam reflector antenna system combining beam hopping and size reduction of effectively used spots," *IEEE Antennas Propag. Mag.*, vol. 54, no. 2, pp. 88–99, Apr. 2012.
- [140] P. Angeletti and R. De Gaudenzi, "A pragmatic approach to massive MIMO for broadband communication satellites," *IEEE Access*, vol. 8, pp. 132 212–132 236, 2020.

[141] Y. Kawamoto, T. Kamei, M. Takahashi, N. Kato, A. Miura, and M. Toyoshima, "Flexible resource allocation with inter-beam interference in satellite communication systems with a digital channelizer," *IEEE Trans. Wireless Commun.*, vol. 19, no. 5, pp. 2934–2945, May 2020.

[142] A. Wang *et al.*, "Noma-enabled multi-beam satellite systems: Joint optimization to overcome offered-requested data mismatches," *IEEE Trans. Veh. Technol.*, vol. 70, no. 1, pp. 900–913, Jan. 2021.

[143] M. Y. Frankel and R. D. Esman, "True time-delay fiber-optic control of an ultrawideband array transmitter/receiver with multibeam capability," *IEEE Trans. Microw. Theory Techn.*, vol. 43, no. 9, pp. 2387–2394, Sep. 1995.

[144] T. Nagayama *et al.*, "Photonics-based millimeter-wave band remote beamforming of array-antenna integrated with photodiode using variable optical delay line and attenuator," *J. Lightw. Technol.*, vol. 36, no. 19, pp. 4416–4422, 2018.



Y. JAY GUO (Fellow, IEEE) received the bachelor's and master's degrees from Xidian University, China, in 1982 and 1984, respectively, and the Ph.D. degree from Xian Jiaotong University, China, in 1987.

He is a Distinguished Professor and the Director of Global Big Data Technologies Centre (GBDTC) at the University of Technology Sydney (UTS), Australia. Prior to this appointment in 2014, he served as a Director in CSIRO for over nine years.

Before joining CSIRO, he held various senior technology leadership positions in Fujitsu, Siemens and NEC in the U.K. His research interest includes antennas, mm-wave and THz communications and sensing systems as well as big data technologies. He has published over 550 research papers including 280 journal papers, most of which are in IEEE Transactions, and he holds 26 patents.

Prof. Guo is a Fellow of the Australian Academy of Engineering and Technology, a Fellow of IEEE and a Fellow of IET, and was a member of the College of Experts of Australian Research Council (ARC, 2016–2018). He has won a number of most prestigious Australian Engineering Excellence Awards (2007, 2012) and CSIRO Chairman's Medal (2007, 2012). He was named one of the most influential engineers in Australia in 2014 and 2015, respectively, and one of the top researchers in Australia in 2020.

He has chaired numerous international conferences and served as guest editors for a number of IEEE publications. He is the Chair of the International Steering Committee, International Symposium on Antennas and Propagation (ISAP). He was the International Advisory Committee Chair of IEEE VTC2017, General Chair of ISAP2022, ISAP2015, IWAT2014 and WPMC'2014, and TPC Chair of 2010 IEEE WCNC and 2012 and 2007 IEEE ISCIT. He served as Guest Editor of special issues on "Antennas for Satellite Communications" and "Antennas and Propagation Aspects of 60-90 GHz Wireless Communications," both in IEEE TRANSACTIONS ON ANTENNAS AND PROPAGATION, Special Issue on "Communications Challenges and Dynamics for Unmanned Autonomous Vehicles," IEEE JOURNAL ON SELECTED AREAS IN COMMUNICATIONS, and Special Issue on "5G for Mission Critical Machine Communications, IEEE NETWORK MAGAZINE.



MARAL ANSARI (Student Member, IEEE) received the M.S. degree (Hons.) in electrical and communication engineering from Tabriz University, Tabriz, Iran, in 2015. She is currently working toward the Ph.D. degree in electrical engineering with the Global Big Data Technologies Center, School of Electrical and Data Engineering, Faculty of Engineering and IT, University of Technology Sydney (UTS), Ultimo, NSW, Australia. Her current research interests include multi-beam antenna arrays, lens antennas, mm-wave beam scanning,

and beamforming networks.



NELSON J. G. FONSECA (Senior Member, IEEE) received the M.Eng. degree from Ecole Nationale Supérieure d'Electrotechnique, Electronique, Informatique, Hydraulique et Télécommunications (ENSEEIH), Toulouse, France, in 2003, the M.Sc. degree from the Ecole Polytechnique de Montreal, Quebec, Canada, also in 2003, and the Ph.D. degree from Institut National Polytechnique de Toulouse – Université de Toulouse, France, in 2010, all in electrical engineering.

He currently works as an Antenna Engineer for the Antenna and Sub-Millimetre Waves Section, European Space Agency (ESA), Noordwijk, The Netherlands. Since November 2020, he has held an Honorary Appointment as Professional Fellow at the University of Technology Sydney (UTS), Australia. His research interests include multiple beam antennas for space missions, beam-former theory and design, ground terminal antennas, transfer of technology from and to terrestrial systems, including 5G networks, and novel manufacturing techniques. He has authored or co-authored more than 220 papers in peer-reviewed journals and conferences and has over 50 patents issued or pending.

Dr. Fonseca served as the Chair of the 38th ESA Antenna Workshop in 2017, and as the Co-Chair of the 2018 IET Loughborough Antennas & Propagation Conference (LAPC 2018). He is currently serving as an Associate Editor for *IET Microwaves, Antennas and Propagation* and for IEEE TRANSACTIONS ON MICROWAVE THEORY AND TECHNIQUES, and as a Topic Editor for IEEE JOURNAL OF MICROWAVES. He has been also serving as the Co-Vice Chair of the newly founded IEEE MTT-S Technical Committee 29 (MTT-29) on Microwave Aerospace Systems. He is a board member of the European School of Antennas and Propagation (ESoA) since January 2019 and is also serving as coordinator of the ESA/ESoA course on Antennas for Space Applications, for which he was voted best lecturer by the participants of the 2020 edition. He is the elected EurAAP Regional Delegate representing Benelux for the term 2021–2023. He received several prizes and awards, including the Best Young Engineer Paper Award at the 29th ESA Antenna Workshop in 2007, an ESA Teamwork Excellence Award in 2020 and multiple ESA technical improvement awards.