

Quantum-Inspired Machine Learning for 6G: Fundamentals, Security, Resource Allocations, Challenges, and Future Research Directions

TRUNG Q. DUONG ¹ (Fellow, IEEE), **JAMES ADU ANSERE**² (Member, IEEE),
BHASKARA NAROTTAMA ³ (Student Member, IEEE), **VISHAL SHARMA**¹ (Senior Member, IEEE),
OCTAVIA A. DOBRE ⁴ (Fellow, IEEE), **AND HYUNDONG SHIN** ⁵ (Fellow, IEEE)

¹School of Electronics, Electrical Engineering and Computer Science, Queen's University Belfast, BT7 1NN Belfast, U.K.

²Department of Electrical and Electronic Engineering, Sunyani Technical University, Sunyani, Ghana

³Department of IT Convergence Engineering, Kumoh National Institute of Technology, Gumi, South Korea

⁴Faculty of Engineering and Applied Science, Memorial University, St. John's, NL A1B 3X5, Canada

⁵Kyung Hee University, Gyeonggi-do 17104, South Korea

CORRESPONDING AUTHOR: JAMES ADU ANSERE (e-mail: jaansere@stu.edu.gh).

This work was supported in part by the U.K. Engineering and Physical Sciences Research Council under Grant EP/P019374/1 and in part by the U.K. Royal Academy of Engineering (RAEng) through the RAEng Research Chair and Senior Research Fellowship scheme under Grant RCSR2021\1141.

ABSTRACT Quantum computing is envisaged as an evolving paradigm for solving computationally complex optimization problems with a large-number factorization and exhaustive search. Recently, there has been a proliferating growth of the size of multi-dimensional datasets, the input-output space dimensionality, and data structures. Hence, the conventional machine learning approaches in data training and processing have exhibited their limited computing capabilities to support the sixth-generation (6G) networks with highly dynamic applications and services. In this regard, the fast developing quantum computing with machine learning for 6G networks is investigated. Quantum machine learning algorithm can significantly enhance the processing efficiency and exponentially computational speed-up for effective quantum data representation and superposition framework, highly capable of guaranteeing high data storage and secured communications. We present the state-of-the-art in quantum computing and provide a comprehensive overview of its potential, via machine learning approaches. Furthermore, we introduce quantum-inspired machine learning applications for 6G networks in terms of resource allocation and network security, considering their enabling technologies and potential challenges. Finally, some dominating research issues and future research directions for the quantum-inspired machine learning in 6G networks are elaborated.

INDEX TERMS 6G networks, machine learning, quantum machine learning, quantum security.

I. INTRODUCTION

Due to the rapid growth of dimensionality of the sample input and output space, huge data processing, and limited storage capacity, data training via traditional machine learning (ML) methods using out-fashioned central processing units is faced with data transmission delays. Specifically, the optimal resource allocation for future wireless communications is a major research challenge. [1], [2]. With the rising pace and continuous demands of wireless data traffic, a prolific beyond fifth-generation (5G) is a promising technology for

future mobile communication [3], [4]. Beyond 5G technology empowers new deployment models and delivers new services with higher data rate, massive network capacity and connectivity, and ultra-reliable low-latency communication.

Sixth-generation (6G) conceptualizes an evolutionary communication platform relying on network software, satellite, and ultra-dense networks that need ultra-high speeds, tactile response time, and cost-effective network [5]. In addition, 6G is expected to improve the foundation of 5G, especially its ultra-high-speed, ultra-low latency, network coverage,

and reliability. These characteristics enable 6G to enhance new applications in virtual reality, immersive, tactile internet, connected robotics and autonomous systems, distributed blockchain technologies and augmented reality.

While most statistical analysis depends on rule-based decision-making, applying classical ML methods in high multi-dimensional data classifications and analysis will encounter critical processing deficiency and huge transmission overheads. As the voluminous number of datasets continues to grow exponentially, new technologies are required to enhance the data processing speed-up and computation efficiency according to Moore's Law [6]. "The curse of dimensionality" coupled with the exploration strategy problem leads to difficult problems in practical applications as the number of datasets grows exponentially with its dimension. Quantum computing (QC) is a rapidly developing subfield in quantum mechanics, energizing quantum computations to efficiently solve complex computational and intractable tasks better than the classical counterpart [7].

The emerging QC is a promising paradigm and can play a significant role in addressing computationally complex problems, such as large-number factorization [8], non-convex optimization, and exhaustive computation and search. The recent literature demonstrates that QC has enviable prospects and is appealing in many practical applications as it considerably speeds-up the costly computational processes. It can stimulate new theoretical learning approaches that are not feasible with the classical computing counterpart. Quantum computers employ quantum phenomena to efficiently solve complex mathematical problems impractical to classical computers. The use of advanced Graphics Processing Units (GPUs) and Tensor Processing Units (TPUs) [9] in QC has demonstrated an extraordinary performance gain in parallel processing potential with computational speed-up and processing efficiency in implementing ML algorithms.

QC has been considered to exploit the powerful quantum mechanics to support fast computing tasks [10]. Recently, QC has been applied to support real-time optimal resource allocation in 6G networks [11]. Many tasks in ML, such as maximum likelihood estimation using hidden variables, principal component analysis, and training of neural networks, require optimization of a non-convex objective function [12]. Optimizing non-convex functions is an NP-hard problem. Classical optimization methods such as gradient descent can get stuck a local optimum or saddle points and may never find the global optimum.

In this paper, we provide the overview of quantum-inspired ML algorithms and their applications to 6G networks. We also introduce the fundamentals of QC, ML algorithms, and the new integrated approach combining QC into machine learning to speed up the computation. We also present the quantum security and optimal resource allocation using quantum-inspired ML algorithms. This paper will shed light on the challenges and future research direction of quantum-inspired ML in 6G networks. The rest of this study is structured as follows: Section II presents the fundamentals of QC. Section III looks

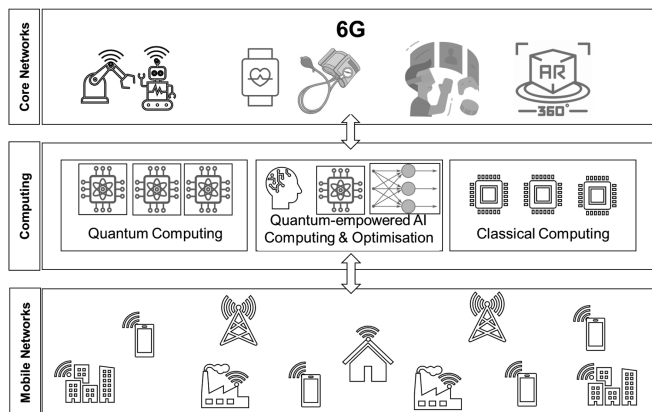

FIGURE 1. An illustration of quantum-inspired machine learning and optimisation in 6G.

at the ML algorithms inspired by QC. Section IV gives an overview on quantum-inspired ML in 6G wireless networks, with a focus on resource allocation. Section V presents quantum-inspired ML in network security and details how it provides 6G networks with strategies to protect against cyber-attack scenarios. Section VI discusses significant research challenges and future directions. Finally, conclusions are drawn in Section VII.

II. FUNDAMENTALS OF QUANTUM COMPUTING

Quantum-inspired ML and optimisation solutions are envisaged to have the potential to revolutionize computation to solve classically intractable problems in 6G networks as shown in Fig. 1.

As observed in the figure, the end user includes operational mobile networks supported by the 6G with a computing component between the two layers. Computing can be done on devices or at the core, depending on the type of applications and their requirements for resources. It is worth noting that for classical computations over the network, on-device operations would improve the performance regarding delays. In contrast, quantum operations require additional resources to accumulate significantly large data, especially for real-time tasks. Quantum-inspired ML algorithms can overcome issues of classical computing and offer a better understanding of virtual and augmented reality, high-convergent data-intense learning, and a better experience of the possible states of the systems. Another dimension to look into is data partitioners that can help disintegrate the data into quantum and classical subsets to help adopt better models and offer a concept of resource utilisation in quantum-inspired ML. The domain of data partitioning would need a clear answer to the applications' requirement of classical or quantum computing. Irrespective of this, for 6G applications, intelligent devices is expected to compete for resources that can be better served with quantum-inspired ML algorithms.

A. QUANTUM COMPUTATION

In QC, the basic unit of quantum information is known as

a quantum bit (simply qubit). Qubit forms a two states that display the peculiarity of quantum mechanics [13]. However, quantum mechanics permits qubits to simultaneously coherent superposition of the two states. This illustrates that a single qubit can be represented as a linear combination of $|0\rangle$ and $|1\rangle$, respectively, as

$$|\psi\rangle = \alpha|0\rangle + \beta|1\rangle \text{ with } \alpha, \beta \in \mathbb{C}, |\alpha|^2 + |\beta|^2 = 1, \quad (1)$$

where α and β are the complex vectors of probability amplitudes [14]. These values determine the occurrence probability of 0 or 1. In addition, a geometrical representation of a qubit space [15], utilizing the polar coordinates θ and ϕ is

$$|\psi\rangle = \cos\left(\frac{\theta}{2}\right)|0\rangle + e^{i\phi}\sin\left(\frac{\theta}{2}\right)|1\rangle, \quad (2)$$

where $0 \leq \phi \leq \pi$ and $0 \leq \theta \leq \pi$.

B. QUANTUM PARALLELISM AND ENTANGLEMENT

The quantum computation process can be assumed as a unitary transformation U coming from input qubits to output qubits [16], [17]. We can superpose two or more quantum states and the potential result will form a new valid quantum state. The quantum processes that the transformation U can perform calculations for different possible values of the quantum input registers simultaneously is known as quantum parallelism. Let the bounded function $f(z)$ for a definite input z , where the quantum computer evaluates $f(z)$ as

$$U_f : |z\rangle|0\rangle \mapsto |z\rangle|f(z)\rangle, \quad (3)$$

where U_f represents a unitary matrix that utilizes the function f [18].

Multiple qubits are depicted as the tensor product of the quantum states of the individual qubits. We consider a k -qubit system, which can be characterized with the tensor product of z autonomous qubits [19] as follows

$$|\Omega\rangle = |\psi_1\rangle \otimes |\psi_2\rangle \otimes \dots \otimes |\psi_z\rangle = \sum_{z=00\dots 0}^{11\dots 1} C_z|z\rangle, \quad (4)$$

where \otimes signifies the tensor product, C_z represents the complex coefficient, $\sum_{z=00\dots 0}^{11\dots 1} |C_z|^2 = 1$, $|C_z|^2$ is the occurrence probability of $|z\rangle$ by measuring the state $|\Omega\rangle$, as the superposition state takes integers from 0 to $2^k - 1$. Based on the Walsh-Hadamard transformation [20], [21] the superposition action through the unitary transformation on a k -qubit register in $|00\dots 0\rangle = |0\rangle \otimes |0\rangle \otimes \dots \otimes |0\rangle$ gives

$$\begin{aligned} & \frac{1}{\sqrt{2^k}}(|00\dots 0\rangle + |00\dots 1\rangle + \dots + |11\dots 1\rangle) \\ &= \frac{1}{\sqrt{2^k}} \sum_{z=0}^{2^k-1} |z\rangle|f(z)\rangle. \end{aligned} \quad (5)$$

The quantum computation for function $f(z)$ is given by

$$U \sum_{z=00\dots 0}^{11\dots 1} C_z|z, 0\rangle = \sum_{z=00\dots 0}^{11\dots 1} C_z U|z, 0\rangle = \sum_{z=00\dots 0}^{11\dots 1} C_z|z, f(z)\rangle. \quad (6)$$

Hence, quantum parallelism uses a single circuit to measure the function simultaneously for multiple values as it exploits the quantum state superposition theory. It is noted that the superposition of $2^k = e^{k \ln 2}$ states enhances quantum computation exponentially faster as compared to the classical counterpart [22].

C. QUANTUM REPRESENTATIONS

In QC, the selected observable system and its eigenstates and eigenactions form a complete set of orthonormal basis in a Hilbert space [13]. Using the Dirac's notation in a Hilbert space, the resultant vector of $|\psi_1\rangle$ and $|\psi_2\rangle$ is $\langle\psi_1|\psi_2\rangle = 1$, and its normalization condition is $|\alpha|^2 + |\beta|^2 = 1$. The orthogonal set of linear superposition of eigenstates $|s_t\rangle$ and eigenactions $|a_t\rangle$ can be represented as

$$|\mathcal{S}\rangle = \sum_k \alpha_k |s_t\rangle, \quad (7)$$

$$|\mathcal{A}\rangle = \sum_k \beta_k |a_t\rangle. \quad (8)$$

Let N_s and N_a represent the number of states and actions, whereby k and m guarantee $N_s \leq 2^k \leq 2N_s$ and $N_a \leq 2^m \leq 2N_a$, respectively.

$$s : \begin{bmatrix} a_1 & a_2 & \dots & a_k \\ b_1 & b_2 & \dots & b_k \end{bmatrix}, \quad |a_i|^2 + |b_i|^2 = 1, \quad i = 1, \dots, k, \quad (9)$$

$$a : \begin{bmatrix} \alpha_1 & \alpha_2 & \dots & \alpha_m \\ \beta_1 & \beta_2 & \dots & \beta_m \end{bmatrix}, \quad |\alpha_i|^2 + |\beta_i|^2 = 1, \quad i = 1, \dots, m. \quad (10)$$

Therefore, the linear superposition becomes

$$|\mathcal{S}_t^{(N_s)}\rangle \rightarrow |\mathcal{S}_t^{(k)}\rangle = \sum_{S=00\dots 0}^{\overbrace{11\dots 1}^k} C_S |\mathcal{S}\rangle, \quad \sum_{S=00\dots 0}^{\overbrace{11\dots 1}^k} |C_S|^2 = 1, \quad (11)$$

$$|\mathcal{A}_t^{(N_a)}\rangle \rightarrow |\mathcal{A}_t^{(m)}\rangle = \sum_{A=00\dots 0}^{\overbrace{11\dots 1}^m} C_A |\mathcal{A}\rangle, \quad \sum_{A=00\dots 0}^{\overbrace{11\dots 1}^m} |C_A|^2 = 1. \quad (12)$$

D. QUANTUM GATES

In QC, a quantum gate is a foundational quantum circuit operating on a number of qubits as building blocks [23]. The computational process in quantum gates is time-reversible. For instance, the reversible Toffoli gate executes Boolean functions using ancilla bits. Quantum gates are unitary operators, assumed as unitary matrices relative to basis [24].

Quantum logic gates can be represented by unitary matrices. A gate which acts on k qubits is characterized as $2^k \times 2^k$. The quantum states form unit vectors in 2^k complex dimensions, and a quantum state is a linear combination of probable

measured outcomes. The vector quantum representation of a single qubit is:

$$|\psi\rangle = \alpha|0\rangle + \beta|1\rangle \rightarrow \begin{bmatrix} \alpha \\ \beta \end{bmatrix}, \quad (13)$$

where α and β are the complex number of probability amplitudes, which define the probability of measuring a 0 or a 1, by updating the state of the qubit. The basis vectors are

$$|0\rangle = \begin{bmatrix} 1 \\ 0 \end{bmatrix} \text{ and } |1\rangle = \begin{bmatrix} 0 \\ 1 \end{bmatrix}. \quad (14)$$

The combined quantum state of two qubits is the tensor product (by the symbol \otimes) of the two qubits. If a quantum system accepts three different states, it is known as a qutrit, while if it admits ρ different states, it is called a qudit.

The vector quantum representation of a two-qubit vector is:

$$\begin{aligned} |\alpha\beta\rangle = |\alpha\rangle \otimes |\beta\rangle &= v_{00}|00\rangle + v_{01}|01\rangle + v_{10}|10\rangle \\ &+ v_{11}|11\rangle \rightarrow \begin{bmatrix} v_{00} \\ v_{01} \\ v_{10} \\ v_{11} \end{bmatrix}. \end{aligned} \quad (15)$$

III. QUANTUM-INSPIRED MACHINE LEARNING APPROACHES

Although QC has emerged as a promising technology for future wireless networks, the classical ML algorithms face challenges in resource allocations and stochastic computation tasks, as they are usually computationally complex and time-consuming [25]. The high computation complexity poses a significant concern to the practical implementation of future wireless networks. QC capabilities incorporated into ML are proposed to address this challenge. The integration of QC capability with the ML algorithms can help in the effective utilization of big data analytic in the IoT environments [26], [27]. The key advantage of QC is in solving practically complex computation tasks and non-convex optimization problems faster with a quantum computer as compared to the classical counterpart, using the best-known classical procedure.

Several studies have tried to recognize practical ML applications to enhance quantum advantage; on the other hand, this is still an active area of research in the swiftly developing field of quantum ML [28], [29]. While ML algorithms estimate immense quantities of data, the applications of quantum ML use qubits and specialized quantum systems to speed up computation, increase data storage, and decrease the processing latency. Before we start to discuss some of the proposed quantum-inspired methods with ML approaches, some fundamentals of ML algorithms will be introduced in the sequel.

The ML field has remarkably gained prominence and is a rapidly developing research area among the and industries to empower ever-growing applications and services for connected environments in the past decade. ML is a subset of artificial intelligence where algorithms learn through interactions with environments using historical data to make predictions about future trends. It has been applied in advanced areas, such as in e-healthcare, robotics, augmented

reality, sequential decision making, and IoT technologies. However, how to speed up the learning process has become a bottleneck challenge for real-time applications of ML methods.

ML is an innovative approach to handling the demand beyond fifth-generation (B5G) re-configurations. This proliferated growth of data-driven learning with high computational complexities has reemerged to prepare fertile grounds for the 6G communication systems. Moreover, ML includes the studying of a huge amount of data, where the data classification and precision measurements are required for proper training and efficient time consumption. Traditionally, ML algorithms can be divided into the following categories based on the features of learning system available.

A. FUNDAMENTALS OF MACHINE LEARNING ALGORITHMS

1) SUPERVISED MACHINE LEARNING

A supervised machine learning (SML) algorithm uses labeled datasets for algorithm training and data classification to accurately predict outcomes [30]. It infers a function through labeled training data made of a set of training examples [31]. In SML, each example is a pair comprised of an input object and an expected output value. An SML algorithm analyzes the training data that creates an inferred function for the purpose of mapping new examples. The work in [32] explored the supervised learning algorithms that improve the probabilistic data classification process. A graph neural network-based framework was proposed to address resource allocation problems in wireless IoT networks [33].

2) UNSUPERVISED MACHINE LEARNING

An unsupervised machine learning (UML) algorithm is used to analyze and classify unlabeled datasets. It finds hidden patterns or data groupings without external human participation. It is an ideal solution for exploratory data analysis, image recognition, and data segmentation due to its ability to find similarities and differences in information. Unsupervised learning models are utilized for three main tasks including clustering, association, and dimensionality reduction. An overview of UML applications in the domain of networking is provided in [34]. In [35], the state-of-the-art UML algorithms focusing on the 6G wireless communication systems were examined. UML algorithms have been employed to tackle the optimization problem of user selection and power allocation under non-orthogonal multiple access (NOMA) scheme [36], power control problems for device-to-device scenarios [37], or user interference [38].

3) REINFORCEMENT MACHINE LEARNING

Reinforcement learning involves the training of ML models for sequential decision making [39]. The agent observes and learns to maximize its reward in a dynamically complex environment. Importantly, the state-action pair interact with the environment to maximize rewards [40].

B. QUANTUM SUPERVISED AND UNSUPERVISED LEARNING

From the classical ML perspective, supervised learning derives the essential practicality from the inference labeled training data, while unsupervised learning determines the hidden patterns and physical composition in the given unlabeled data [41]. By applying quantum functionalities with ML, QML algorithms can provide exponential speed-ups for large multi-dimensional data processing in both supervised and unsupervised learning approaches over classical ML algorithms. General optimization problems for quantum algorithms using ML methods were investigated to improve the quantum evaluation speed-up compared to the classical algorithms [42]. The future quantum ML algorithms by combining QC and ML through Moore's law to create a new "rebooted computer" was introduced in [43]. A thorough study was investigated on supervised and unsupervised learning for quantum pattern recognition, quantum clustering, quantum classification, and quantum regression process [44], [45].

C. QUANTUM REINFORCEMENT LEARNING (QRL)

QRL designs RL agents that depend on quantum computation models [46]. A quantum intelligent agent interacts with the environment and takes actions to maximize its cumulative reward. It finds a balance between exploration and exploitation of the environment and models through a Markov decision process (MDP). The important difference between the classical dynamic programming methods and QRL algorithms is that the QRL has no prior knowledge of the mathematical model of the MDP and mostly targets large MDPs with infeasible approach [47]. The objective of a QRL agent is to learn a policy $\pi : A \times S \rightarrow [0, 1]$, $\pi(a, s) = \Pr(a_t = a \mid s_t = s)$ that maximizes the probable cumulative reward. From the learning policy, A represents the action space and S is the state space. In the QRL method, the criteria of optimality are defined as follows:

1) POLICY SELECTION

The action selection of the agent is modeled as a mapping in the form

$$\begin{aligned} \pi : A \times S &\rightarrow [0, 1] \\ \pi(a, s) &= \Pr(a_t = a \mid s_t = s). \end{aligned} \quad (16)$$

The policy map provides the probability of action taking a when in state s and $\pi(a, s)$ indicates the probability of selecting action a based on the state space s under policy π .

2) VALUE SELECTION

$$\begin{aligned} V^\pi(s) &= \mathbb{E} \{r_{(t+1)} + \gamma r_{(t+2)} + \dots \mid s_t = s, \pi\} \\ &= \mathbb{E} \left[r_{(t+1)} + \gamma V_{s_{(t+1)}}^\pi \mid s_t = s, \pi \right] \\ &= \sum_{a \in A} \pi(s, a) \left[r(a, s) + \gamma \sum_{s'} P(a, s') V^\pi(s') \right] \end{aligned} \quad (17)$$

where $\gamma \in [0, 1]$ represents the rewarding discount factor, $P(a, s') = \Pr\{s_{t+1} = s' \mid s_t = s, a_t = a\}$ means the probability for state transition and $r(a, s) = E\{r_{t+1} \mid s_t = s, a_t = a\}$ is the one-step expected reward [48]. Moreover, the optimal state-value is given by

$$\begin{aligned} V^*(s) &= \max_{a \in A_s} \left[r_s^a + \gamma \sum_{s'} P_{ss'}^a V_{(s')}^* \right] \\ \pi^* &= \arg \max_{\pi} V_{(s)}^\pi \quad \forall s \in S. \end{aligned} \quad (18)$$

Similarly, the optimal state-action pair $Q^*(s, a)$, which is the Bellman's optimality equation [49] can be expressed as

$$\begin{aligned} Q^\pi(s, a) &= \mathbb{E} \{r_{(t+1)} + \gamma r_{(t+2)} + \dots \mid s_t = s, a_t = a, \pi\} \\ &= r(s, a) + \gamma \sum_{s'} P(a, s') \max_{a'} \pi(s', a') \\ Q^*(s, a) &= \max_{\pi} Q(s, a) = r(s, a) + P(a, s') \max_{a'} Q^\pi(s', a'). \end{aligned} \quad (19)$$

Therefore, the one-step temporal-difference updating rule of $V(s)$ can be defined as

$$V(s) \leftarrow V(s) + \beta (r + \gamma V(s') - V(s)), \quad (20)$$

where $\beta \in (0, 1)$ denotes the quantum learning rate and $\gamma \in [0, 1]$ is the discount factor.

Notably, the quantum superposition states and parallelism are used to represent the eigenstates in quantum-inspired RL, where the random quantum state observation is simulated through the collapse of quantum measurement [50], [51]. However, the reward from the dynamic environment is employed to update the eigenactions to maximize the reward functions.

D. QUANTUM NEURAL NETWORK (QNN)

QNNs are made of computational neural network models that use the principles of quantum mechanics [52]. Ideal research in QNNs combines classical artificial neural network (NN) models employed in ML-based on quantum information to design efficient algorithms as training classical NNs encounters difficulty in big data applications [53]. However, it is hoped that the implementation of a quantum computer will be faster as the QNN models are mostly in theoretical experiments. Most QNNs are prepared as feed-forward networks. Compared with classical computers, this structure functions on input from one layer of qubits and forward that input onto an additional layer of qubits [54], [55]. The layer of qubits estimates the information, advancing the output to the next layer. Finally, the path goes to the final layer of qubits. Theoretically, QNNs can be trained similarly as in the training process of classical NNs. The only difference in their operations lies in the communication between the network layers. For classical NNs, at the end of a given process, the existing perceptron duplicates its output to the next perceptron layer of the network. Conversely, in a QNN, as each perceptron is a qubit, it violates the no-cloning theorem, which is impossible

to generate an independent and identical copy of the quantum state [56].

A cost function is used to determine the effectiveness of a NN, which measures the network output proximity to the expected output [57]. In a classical NN, the weights (w) and biases (b) at each step define the cost function outcome, $C(w, b)$. While training a classical NN, the (w) and (b) are adjusted after each iteration according to

$$C(w, b) = \frac{1}{N} \sum_i \frac{\|y(i) - a^{\text{out}}(i)\|}{2}, \quad (21)$$

where $y(i)$ denotes the expected output and $a^{\text{out}}(i)$ is the actual output. $C(w, b) = 0$ means that the cost function is optimized [58]. In the QNN, the cost function is evaluated by measuring the reliability of the outcome state (ρ^{out}) with the preferred outcome state (ϕ^{out}) according to

$$C = \frac{1}{N} \sum_i \langle \phi^{\text{out}} | \rho^{\text{out}} | \phi^{\text{out}} \rangle. \quad (22)$$

Hence, the unitary transformers are modified after each iteration, where the cost function is optimized at $C = 1$.

E. QUANTUM-INSPIRED SUPPORT VECTOR MACHINE (SVM)

In classical ML algorithms, SVMs are supervised learning models related to learning algorithms that analyze datasets of classification and regression analysis [59]. SVMs are one of the most robust prediction methods, which apply statistical learning methods to categorize unlabeled data. An SVM training algorithm builds a model in a probabilistic classification setting to allocate new examples to one category [59]. It represents training examples to points to maximize the width of the difference between the two categories and new examples mapped into that same space into category prediction [60].

Besides linear classification, SVMs perform a non-linear classification efficiently using the kernel trick to map their inputs into multiple high-dimensional feature spaces. As such, QC functionalities can be introduced into SVMs in qubits-based manner to represent data [61]. The SVM algorithm complexity scales polynomially with the high dimensionality of data space and the number of data points. To address the issue of big data, a quantum-inspired SVM algorithm has been proposed to enhance achieve exponential speed-up for least squares SVM [62].

F. QUANTUM SEARCH ALGORITHMS FOR MACHINE LEARNING

To provide high computational speed-up and processing efficiency for quantum computers, QC algorithms, e.g., Shor's period-finding algorithm and Grover's search algorithm, constitute the two masterpieces of quantum-computational search methods.

1) SHOR'S ALGORITHM

The Shor's factoring algorithm enhances the method of finding the period of a function faster. Shor proposed a quantum algorithm to factorize integers efficiently than a classical computer [63]. A classical reduction of determining a factoring problem is computationally complex, slow, and limited processing power. Shor's algorithm relies on quantum parallelism to make a superposition states function in one step. It employs the quantum Fourier transform to enhance the multiple representations of superposition states. With high probability, determining the quantum state obtains information through a classical means, and extracts the period factor. From classical ML methods, the Shor's algorithm runs in $O(n^2 \log n \log \log n)$ time complexity for computation with the space of $O(n \log n \log \log n)$. Therefore, the total runtime complexity for a single iteration [64] of the Shor's algorithm is $O(n^2 \log n \log \log n)$, in polynomial time.

2) GROVER'S ALGORITHM

This is a quantum algorithm for unstructured search with high probability of producing a particular output value. Grover's algorithm tackles the frequent black box challenges [65]. It effectively finds a solution with $O(\sqrt{N})$ transmits to the oracle, compared to best executable classical approaches require $O(N)$ calls. The query complexity of Grover's algorithm $O(\sqrt{N})$ is best-known to be optimal and improvement over the classical case translates to a computational speed-up and processing efficiency. Grover's algorithm is much simpler to reach than Shor's, and has an easier geometrical interpretation. Grover's algorithm has several applications, capable of reducing the computational complexity exponentially.

IV. QUANTUM RADIO RESOURCE ALLOCATION

A. QUANTUM MARKOV CHAIN THEORY

In classical Markov process, stochastic behavior and time-varying wireless conditions significantly degrade the system performance in the random environment. This affects the accurate predictions for huge dimensional data in dynamic large-scale environment [66]. To address this, quantum Markov chain theory is a promising approach, where a stochastic model is applied in determining sequence of possible events depending on the probability of past and present events. Markov chains as a statistical models have many real-world applications, such as speech and face recognition, mapping of animal life population dynamics, and modelling of biological populations evolution [67].

In stochastic processes, the quantum Markov chain is a reformulation of the classical Markov chain concepts, replacing the classical interpretations of probability with quantum probability. Let (\mathcal{E}, ρ) , where ρ represents the quantum density matrix and \mathcal{E} is the quantum communication channel, whereby $\mathcal{E} : \mathcal{B} \otimes \mathcal{B} \rightarrow \mathcal{B}$ forming a completely positive trace-preserving map, where \mathcal{B} is C-algebra of bounded operators. This must satisfy the quantum Markov condition [68],

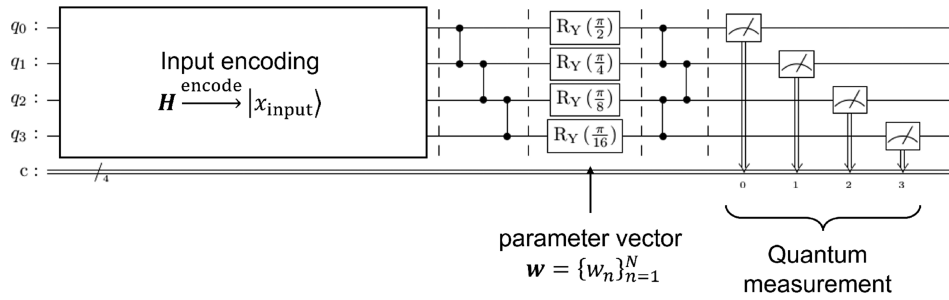

FIGURE 2. An example of quantum operation for wireless optimization.

that $\text{Tr} \rho(b_1 \otimes b_2) = \text{Tr} \rho E(b_1, b_2)$ for all $b_1, b_2 \in \mathcal{B}$. Therefore, a tripartite state $\rho_{\mathcal{A} \otimes \mathcal{B} \otimes \mathcal{C}} \in \mathcal{S}(\mathcal{A} \otimes \mathcal{B} \otimes \mathcal{C})$ is known as quantum Markov chain following the order $\mathcal{A} \leftrightarrow \mathcal{B} \leftrightarrow \mathcal{C}$ if and only if there exists a recovery mapping set $R_{\mathcal{B} \rightarrow \mathcal{BC}} \in \{(\mathcal{B}, \mathcal{B} \otimes \mathcal{C})\}$ such that $\rho_{\mathcal{ABC}} = R_{\mathcal{B} \rightarrow \mathcal{BC}} \in (\rho_{\mathcal{AB}})$.

B. QUANTUM THEORETIC GAME THEORY

The quantum game theory forms an extension of classical game theory through a quantum superposition state and entanglement, through optimal strategic behavior by agents using a randomization device or a communication protocol [69]. Primarily, it differs from classical game theory in terms of superposition states, quantum entanglement of initial states to create new quantum amplitudes, and quantum games work in the Hilbert space. A classical and quantum game theory and review on the application of the methods of quantum mechanics were introduced [70]. Comprehensive reviews are provided on the current status of research quantum game theory.

C. QUANTUM OPTIMIZATION FOR FUTURE WIRELESS COMMUNICATION

Furthermore, recent frameworks envisage a significant increase of multi-dimensional optimization variables in 6G communication [71], [72]. For instance, a huge number of served devices may lead to more complex beam optimization [73]. In addition, by employing novel resources (e.g., power-based resource allocation in power-domain NOMA [74]), the resource assignment becomes more complex.

Quantum-based algorithms may provide a solution to this issue. In particular, quantum-based search methods may offer quadratic time reduction in finding the optimization solution; as mentioned earlier, classical and quantum search methods yield $\mathcal{O}(N)$ and $\mathcal{O}(\sqrt{N})$, respectively (exhaustive classical search and Grover’s quantum search are considered) [75], [76]. Moreover, a quantum-based NN model may be utilized for the beam-user assignment problem.

An example of quantum operation for wireless optimization is showcased in Fig. 2. Here, the channel information (denoted as \mathbb{H} in Fig. 2) is encoded into the quantum circuit using a set of RY gates (e.g., rotation around y axis). Moreover, to tune the quantum ansatz, another set of RY gates with set of phases

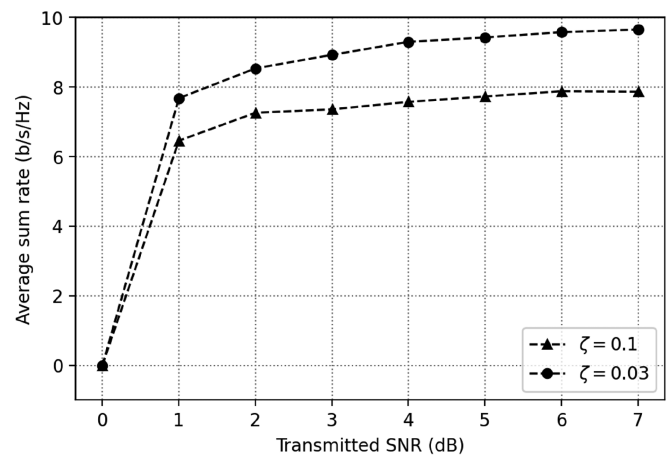

FIGURE 3. A particular result of using quantum-based optimization for cell-free transmitter assignment. In the figure, ζ indicates the inter-beam interference factor [77].

w is employed; the range of each n th element of parameter set w can be particularly defined as $w_n \in \{-\frac{\pi}{2}, \frac{\pi}{2}\}$. In the end, the result of quantum measurement is decoded as optimization variables (e.g., estimated power ratio and beamforming vector). Using quantum-based optimization, different wireless optimization cases can be considered as follows.

- In Fig. 3, the quantum-based optimization was used for transmitter assignment for a number of N_{user} users in cell-free communication. The performance (in terms of achieved sum rate of users) is shown with respect to transmit signal-to-noise ratio (SNR).
- In Fig. 4, the quantum-based optimization was employed for beam optimization in power-domain NOMA. The considered system assumed $N_{\text{user}} = 3$. Let $|h_1|^2$, $|h_2|^2$, and $|h_3|^2$ be the channel vectors between the transmitting base station and receiving users U_1 , U_2 , and U_3 , respectively, where user channel gain values are given by $|h_1|^2 \geq |h_2|^2 \geq |h_3|^2$, accordingly. NOMA power allocation ratio coefficients for users U_1 , U_2 , and U_3 , was assumed as $\lambda_1 = 0.1$, $\lambda_2 = 0.2$, $\lambda_3 = 0.7$, respectively.

V. QUANTUM SECURITY

Quantum cryptography exploits the quantum mechanical properties to execute cryptographic tasks. In quantum cryptography, data are encrypted and transmitted in a virtually

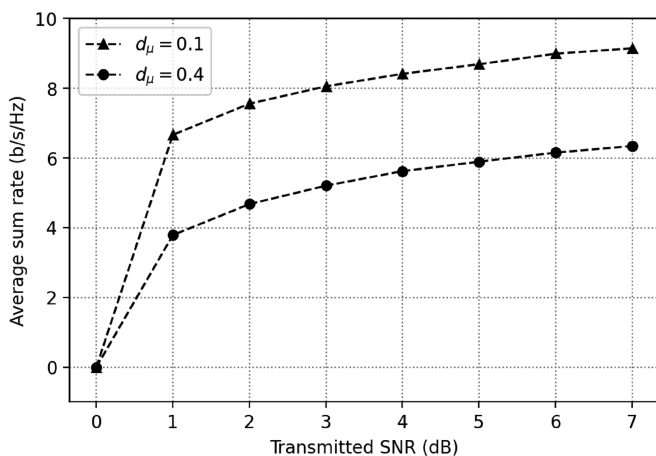

FIGURE 4. A particular result of using quantum-based optimization for NOMA beam assignment [78]. In the figure, d_μ denotes normalised user's distance to the base station.

unhackable fashion [79]. A well-known example of quantum cryptography is called quantum key distribution, which provides an information-theoretically secure solution to enhance the key distribution exchange, which was impossible using only classical communication [80]. Due to the no-cloning theorem, the quantum states are applied to detect intruders in quantum key distribution. In quantum-safe cryptography, cryptographic algorithms are designed to secure against malicious attacks and produce quantum-safe certificates. The authors in [81] reviewed quantum public-key cryptosystem, quantum identity authentication, quantum key agreement, and quantum secure direct communication offers unconditional security.

From the ML perspective, quantum computers would need to be predicted for their circuit and, more importantly, the role of oracles, which are used differently for algorithms providing security to the networks and infrastructures. Security of quantum-inspired ML for 6G would need a considerable understanding of the post-quantum attacks as the protocols built for quantum-enabled systems are breachable with enhanced capacity, computing power and cloning [82]. Building fault-tolerant solutions for deploying quantum-inspired ML is an important direction to explore, and it is worth considering how existing solutions would be scaled to fit the requirements of security for the new generation of radios. With the ML layer playing an important role in future radios, fitting the quantum protocols from the user's and system's perspective need additional resources and capacity to withstand the limitations, adversarial issues and key-generation problems that might open into new threats for the security protocols [83]. If stronger and easily customizable circuits become a reality [84], understanding the operations of the ML and features of the security would no longer be a concern which would open the Pandora box of new cyber threats against 6G systems. Moreover, the security functions which are key to modern radios would need revisiting, considering the profiling of every component and its possible security against quantum threats.

For 6G networks enabled with quantum-inspired ML, security is motivated to prevent known and unknown attacks that may arise because of the computing capacity of quantum computers. ML algorithms backed by high computing capacity increase attack risks and vulnerabilities across different network components, as illustrated in Fig. 5. These may lead to the following attacks:

1) AUTHENTICATION

Ensuring that the quantum-inspired ML does not yield any information that can lead to spoofing attacks which are risks due to authentication failures of the network [81]. With the quantum computers' high computing capacity and better convergence of ML algorithms, the authentication security would rely on the secret keys and the protocol functionalities.

2) ACCESS CONTROL

A spoofed network can release the details of the ML algorithms working behind the scenes. Here, access control needs management for network devices and the channels used to provide radio services.

3) DENIAL OF SERVICE

If the authentication and access control are violated, the networks are prone to DoS attacks, which quantum-inspired ML must overcome in post-quantum scenarios. In a conventional setup, quantum-inspired ML can prevent DoS as it would make it hard for classical computing to determine the system's settings. Hence, quantum-inspired ML would provide more robust mechanisms to prevent networks against DoS attacks but up to the extent when post-quantum adversarial models can crack them.

4) SECURITY FUNCTION EXPLOITS

Quantum-inspired ML offers a wide range of utilities from the functional security point of view in 6G networks. It is evident that from 4G/LTE onwards, several functions are used to ensure the seamless working of the network, which also facilitates their security. With quantum-inspired ML, strategies can be built to decide the location and operations of these functions, such as positioning the access control and mobility management entity, offering adaptive radio management, and supporting highly convergent software-defined radio [85]. However, at the same instance, the security of these functions become paramount as an attack on one of the security function would expose the periphery of all the deployed security functions and reverse operations on the ML could lead to possible information disclosure.

The attacks above are primary threats to quantum-inspired ML for 6G networks. The amount of data replicated across the network would define the extent of harm caused to the users. It is essential to understand the exposure risks of the networks if the security fails. Moreover, these risks would be accompanied by possible remedies that must be in place to limit the impact of the security failures if the underlying

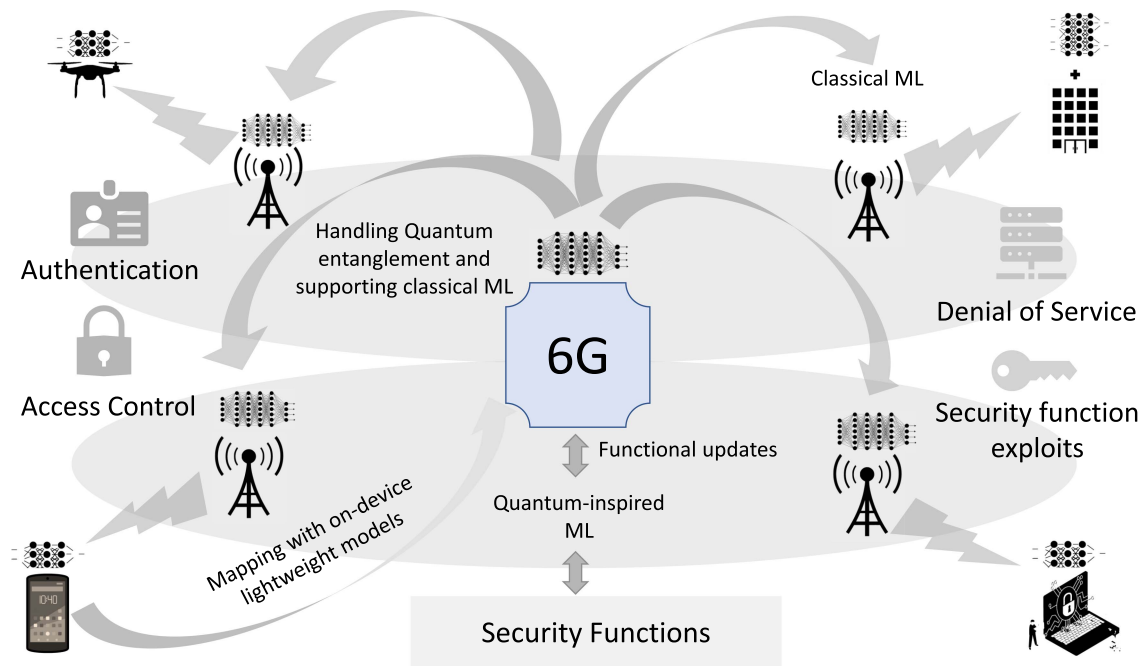

FIGURE 5. An illustration of the applicability of quantum-inspired ML for 6G with observable security check points.

ML algorithms are exposed to cyber-attacks [86]. Here, the considerable challenge would be from the post-quantum adversarial modelling, which would operate with the ideology of affecting the quantum and classical ML for networks.

VI. OPEN RESEARCH ISSUES AND FUTURE DIRECTIONS

This section briefly examines the research challenges and future directions in the development of quantum ML algorithms and their applications in 6G networks.

A. RESEARCH ISSUES

The 5G and beyond 5G networks towards 6G have seen innovative-driven developments recently. There are many challenges to consider while developing 5G requirements on higher data rate, high reliability, ultra-low latency, and security. The deployment of large-scale QC faces many critical issues such as architecture, model optimization, security, and fabrication as quantum computers are envisaged to process and store complex quantum representation states in a single bit. The quantum computers need an extremely low temperature to operate bits and thus, require an accurate process to handle the delicate quantum states. Verification becomes challenging due to the difficulty in measuring the quantum state accurately.

A quantum ML algorithm must be exponentially faster and computationally efficient for complex multi-dimensional than a classical ML algorithm for the same function. This poses the practical design and implementation of a good quantum algorithm as a challenging task. In reality, quantum ML algorithms and their related applications are still in the infant stage, and

very little information is known regarding the quantum number of gates and how to implement a quantum ML algorithm in quantum computers. At this theoretical phase, assured fully of its successful complexity integration with classical counterparts and implementations hinges on imbalance to predict the practical processing efficiency between quantum methods and classical computers.

B. FUTURE DIRECTIONS

It is anticipated that this study can be extended into several research directions. Below are some of the selected directions as presented as follows.

1) IN-DEPTH HYBRID QUANTUM ALGORITHM ANALYSIS

This study starts with classical computers and QC, which covers the major issues in different fields. Specifically, a topic like a hybrid algorithm, proposed algorithms that partially run both on quantum computers and classical computers can be further investigated. In areas such as significance, comparative and simulation analysis, the hybrid algorithm would be exciting to explore in the future.

The novel transformation of wireless networks makes 6G technologies significantly different from 5G due to the high degree of heterogeneity characterized by radio access technologies, intelligent communications, network infrastructures, and storage resources [87]. 6G foresees evolving four-tier network architecture expansion by integrating key enabling technologies such as millimetre-wave and quantum communications. Huge data processing in wireless networks is growing tremendously and opens new intelligent enablers for dynamic network environments [88]. By employing QC

techniques, the exponential processing speed and multi-functional global quantum network will be enhanced [89].

2) QUANTUM COMPUTING FOR DRONE NETWORKS AND TRAJECTORY PLANNING

The recent developments of quantum drones and drone-to-satellite connectivity and communications have been anticipated for real-time applications. An in-depth study is required to examine the quantum data processing, techniques, trajectory planning, and algorithms considerably for quantum drones and related networks.

3) QUANTUM-INSPIRED CRYPTOSYSTEM FOR BLOCKCHAIN

The fast progress and ubiquitous applications of QC have exposed the vulnerability of the Grover's and Shor's algorithms for future networks. This poses an imminent threat to both public-key cryptography and hash functions on these algorithms, and redesigning methods using a QC approach is needed for quantum-resistant cryptosystems. Further investigations are needed on the potential application of quantum-inspired blockchain transactions. Hence, the quantum-inspired blockchain developers are required to determine quantum key generation approaches to optimize blockchain efficiency, and this would be interesting remarkably for further research attention.

4) QUANTUM-INSPIRED MULTIMEDIA PROCESSING

Quantum image processing is an emerging research area focused on broadening the classical image processing tasks and functions to the QC model. By using the QC technique, several quantum images captured, manipulated, and recovered in different formats would be possible. However, it is anticipated that the quantum entanglement, parallelism, and superposition states would offer improvements in computation processing speed, efficient image and data storage, and guaranteed security.

5) QUANTUM-INSPIRED SATELLITE COMMUNICATIONS

In today's communication networks, a large amount of data that are transferred through satellites require high processing speedup and ultra-low communication latency [90]. By using quantum communication protocols, the data-driven speed and processing efficiency will effectively improve space communications.

6) QUANTUM-INSPIRED NETWORK OPTIMIZATION FOR IOT APPLICATIONS

The IoT interconnects millions of smart communication devices for ubiquitous applications and services [91]. With massive device connectivity and communications, it becomes indispensable to employ high multi-dimensional accuracy data analysis for achieving an optimal IoT environment. Therefore, novel QC-empowered optimization techniques to maximize data accuracy are needed in a real-time optimized IoT environment application.

7) QUANTUM-INSPIRED SECURED CONNECTED-VEHICULAR COMMUNICATIONS

The key objective of the 6G network is using several promising communication technologies, such as software-defined networking, vehicular networks, multi-user mobile edge, and cloud computing [92]. Supporting a huge number of connected vehicles with innovating 5G advanced technologies poses a tremendous challenge for security, trust, and privacy [93]. Thus, secured communication mechanisms and protocols are fundamentally needed for 5G networks to tackle these security challenges in information sharing and data protection protocols for connected vehicles.

VII. CONCLUSION

This work has extensively reviewed the emerging technologies over QC with ML, 6G technology, classical computers, and quantum ML algorithms. More importantly, several potential applications for quantum ML algorithms have been identified and discussed. Furthermore, this study provides the recent novel applications of quantum-inspired future networks, research challenges and future directions. Therefore, this study provides insights into QC with ML and offers substantial guidelines for the quantum developers and researchers of the next generation of quantum computers and how they transform the quantum ML algorithms into practical applications.

REFERENCES

- [1] D. W. K. Ng, T. Q. Duong, C. Zhong, and R. Schober, *Wireless Information and Power Transfer: Theory and Practice*. Hoboken, NJ, USA: Wiley, 2019.
- [2] E. Gyamfi, J. A. Ansere, M. Kamal, M. Tariq, and A. Jurcut, "An adaptive network security system for iot-enabled maritime transportation," *IEEE Trans. Intell. Transp. Syst.*, to be published, doi: [10.1109/TITS.2022.3159450](https://doi.org/10.1109/TITS.2022.3159450).
- [3] N.-S. Vo, T. Q. Duong, M. Guizani, and A. Kortun, "5G optimized caching and downlink resource sharing for smart cities," *IEEE Access*, vol. 6, pp. 31457–31468, Aug. 2018.
- [4] Q. Wu, G. Y. Li, W. Chen, D. W. K. Ng, and R. Schober, "An overview of sustainable green 5G networks," *IEEE Wireless Commun.*, vol. 24, no. 4, pp. 72–80, Aug. 2017.
- [5] M. Giordani, M. Polese, M. Mezzavilla, S. Rangan, and M. Zorzi, "Toward 6G networks: Use cases and technologies," *IEEE Commun. Mag.*, vol. 58, no. 3, pp. 55–61, Mar. 2020.
- [6] G. Moore, "Moore's law," *Electron. Mag.*, vol. 38, no. 8, 1965, Art. no. 114.
- [7] J. Vos, *Quantum Computing in Action*. New York, NY, USA: Simon and Schuster, 2022.
- [8] T. Hey, "Quantum computing: An introduction," *Comput. Control Eng. J.*, vol. 10, no. 3, pp. 105–112, 1999.
- [9] M. Hirvensalo, *Quantum Computing*. Berlin, Germany: Springer, 2003.
- [10] J. Nötzel and S. DiAdamo, "Entanglement-enhanced communication networks," in *Proc. IEEE Int. Conf. Quantum Comput. Eng.*, 2020, pp. 242–248.
- [11] T. Q. Duong, L. D. Nguyen, B. Narottama, J. A. Ansere, D. V. Huynh, and H. Shin, "Quantum-inspired real-time optimisation for 6G networks: Opportunities, challenges, and the road ahead," *IEEE Open J. Commun. Soc.*, vol. 3, pp. 1347–1359, 2022.
- [12] D. Cozzolino, B. Da Lio, D. Bacco, and L. K. Oxenløwe, "High-dimensional quantum communication: Benefits, progress, and future challenges," *Adv. Quantum Technol.*, vol. 2, no. 12, 2019, Art. no. 1900038.
- [13] C. P. Williams et al., *Explorations in Quantum Computing*. Berlin, Germany: Springer, 1998.

- [14] A. Ekert and D. Bouwmeester, *The Physics of Quantum Information: Quantum Cryptography, Quantum Teleportation, Quantum Computation*. Berlin, Germany: Springer, 2000.
- [15] D. Daoyi, C. Chunlin, and L. Hanxiang, "Reinforcement strategy using quantum amplitude amplification for robot learning," in *Proc. Chin. Control Conf.*, 2007, pp. 571–575.
- [16] D. C. Marinescu, "The promise of quantum computing and quantum information theory-quantum parallelism," in *Proc. 19th IEEE Int. Parallel Distrib. Process. Symp.*, 2005, pp. 3–pp.
- [17] C.-P. Yeang, "Engineering entanglement, conceptualizing quantum information," *Ann. Sci.*, vol. 68, no. 3, pp. 325–350, 2011.
- [18] T. Albash and D. A. Lidar, "Adiabatic quantum computation," *Rev. Modern Phys.*, vol. 90, no. 1, 2018, Art. no. 015002.
- [19] M. Nakahara, *Quantum Computing: From Linear Algebra to Physical Realizations*. Boca Raton, FL, USA: CRC Press, 2008.
- [20] D. A. Devi, Y. S. Chandana, and M. Akshitha, "Analysis of Walsh-Hadamard transformation with CFBMC communication," in *Proc. Int. Conf. Artif. Intell. Smart Syst.*, 2021, pp. 1246–1252.
- [21] W. Scherer, *Mathematics of Quantum Computing*. Berlin, Germany: Springer, 2019.
- [22] D. Cuomo, M. Caleffi, and A. S. Cacciapuoti, "Towards a distributed quantum computing ecosystem," *IET Quantum Commun.*, vol. 1, no. 1, pp. 3–8, 2020.
- [23] D. P. DiVincenzo, "Two-bit gates are universal for quantum computation," *Phys. Rev. A*, vol. 51, no. 2, 1995, Art. no. 1015.
- [24] D. P. DiVincenzo, "Quantum gates and circuits," *Proc. Roy. Soc. London. Ser. A: Math., Phys. Eng. Sci.*, vol. 454, no. 1969, pp. 261–276, 1998.
- [25] S. Akbar and S. K. Saritha, "Qml based community detection in the realm of social network analysis," in *Proc. 11th Int. Conf. Comput., Commun. Netw. Technol.*, 2020, pp. 1–7.
- [26] M. Schuld, I. Sinayskiy, and F. Petruccione, "An introduction to quantum machine learning," *Contemporary Phys.*, vol. 56, no. 2, pp. 172–185, 2015.
- [27] T. M. Khan and A. Robles-Kelly, "Machine learning: Quantum vs classical," *IEEE Access*, vol. 8, pp. 219275–219294, 2020.
- [28] J. D. Martín-Guerrero and L. Lamata, "Quantum machine learning: A tutorial," *Neurocomputing*, vol. 470, pp. 457–461, 2022.
- [29] R. Divya and J. D. Peter, "Quantum machine learning: A comprehensive review on optimization of machine learning algorithms," in *Proc. Fourth Int. Conf. Microelectronics, Signals Syst.*, 2021, pp. 1–6.
- [30] A. Singh, N. Thakur, and A. Sharma, "A review of supervised machine learning algorithms," in *Proc. 3rd Int. Conf. Comput. Sustain. Glob. Develop.*, 2016, pp. 1310–1315.
- [31] G. Huang, S. Song, J. N. Gupta, and C. Wu, "Semi-supervised and unsupervised extreme learning machines," *IEEE Trans. Cybern.*, vol. 44, no. 12, pp. 2405–2417, Dec. 2014.
- [32] R. Saravanan and P. Sujatha, "A state of art techniques on machine learning algorithms: A perspective of supervised learning approaches in data classification," in *Proc. 2nd Int. Conf. Intell. Comput. Control Syst.*, 2018, pp. 945–949.
- [33] T. Chen, X. Zhang, M. You, G. Zheng, and S. Lambotharan, "A GNN-based supervised learning framework for resource allocation in wireless IoT networks," *IEEE Internet Things J.*, vol. 9, no. 3, pp. 1712–1724, Feb. 2022.
- [34] M. Usama et al., "Unsupervised machine learning for networking: Techniques, applications and research challenges," *IEEE Access*, vol. 7, pp. 65579–65615, 2019.
- [35] V. P. Rekkas, S. Sotiroidis, P. Sarigiannidis, G. K. Karagiannidis, and S. K. Goudos, "Unsupervised machine learning in 6G networks -state-of-the-art and future trends," in *Proc. 10th Int. Conf. Modern Circuits Syst. Technol.*, 2021, pp. 1–4.
- [36] J. Ren, Z. Wang, M. Xu, F. Fang, and Z. Ding, "An em-based user clustering method in non-orthogonal multiple access," *IEEE Trans. Commun.*, vol. 67, no. 12, pp. 8422–8434, Dec. 2019.
- [37] Z. Fan, X. Gu, S. Nie, and M. Chen, "D2d power control based on supervised and unsupervised learning," in *Proc. 3rd IEEE Int. Conf. Comput. Commun.*, 2017, pp. 558–563.
- [38] Q. N. Le, V.-D. Nguyen, O. A. Dobre, N.-P. Nguyen, R. Zhao, and S. Chatzinotas, "Learning-assisted user clustering in cell-free massive MIMO-NOMA networks," *IEEE Trans. Veh. Technol.*, vol. 70, no. 12, pp. 12872–12887, Dec. 2021.
- [39] R. S. Sutton, "Introduction: The challenge of reinforcement learning," in *Reinforcement Learning*. Berlin, Germany: Springer, 1992, pp. 1–3.
- [40] Z. Zhang, D. Wang, and J. Gao, "Learning automata-based multiagent reinforcement learning for optimization of cooperative tasks," *IEEE Trans. Neural Netw. Learn. Syst.*, vol. 32, no. 10, pp. 4639–4652, Oct. 2021.
- [41] W. Huggins, P. Patil, B. Mitchell, K. B. Whaley, and E. M. Stoudenmire, "Towards quantum machine learning with tensor networks," *Quantum Sci. Technol.*, vol. 4, no. 2, 2019, Art. no. 024001.
- [42] S. P. and P. Kumari, "Quantum algorithms for machine learning and optimization," in *Proc. 2nd Ph.D. Colloq. Ethically Driven Innov. Technol. Soc.*, 2020, pp. 1–2.
- [43] E. P. DeBenedictis, "A future with quantum machine learning," *Comput.*, vol. 51, no. 2, pp. 68–71, 2018.
- [44] E. Aïmeur, G. Brassard, and S. Gambs, "Quantum speed-up for unsupervised learning," *Mach. Learn.*, vol. 90, no. 2, pp. 261–287, 2013.
- [45] L. Oneto, S. Ridella, and D. Anguita, "Quantum computing and supervised machine learning: Training, model selection, and error estimation," in *Quantum Inspired Computational Intelligence*. Amsterdam, The Netherlands: Elsevier, 2017, pp. 33–83.
- [46] D. Dong, C. Chen, H. Li, and T.-J. Tarn, "Quantum reinforcement learning," *IEEE Trans. Syst., Man, Cybern., Part B*, vol. 38, no. 5, pp. 1207–1220, Oct. 2008.
- [47] V. Dunjko, J. M. Taylor, and H. J. Briegel, "Advances in quantum reinforcement learning," in *Proc. IEEE Int. Conf. Syst., Man, Cybern.*, 2017, pp. 282–287.
- [48] P. Lin, Q. Song, J. Song, L. Guo, and A. Jamalipour, "Edge intelligence-based joint caching and transmission for QoE-aware video streaming," in *Proc. IEEE/CIC Int. Conf. Commun. China*, 2020, pp. 214–219.
- [49] R. S. Sutton and A. G. Barto, *Reinforcement Learning: An Introduction*. Cambridge, MA, USA: MIT Press, 2018.
- [50] R. De Wolf, "Quantum communication and complexity," *Theor. Comput. Sci.*, vol. 287, no. 1, pp. 337–353, 2002.
- [51] G.-L. Long and H. Zhang, "Practical quantum secure direct communication," in *Proc. Cross Strait Radio Sci. Wireless Technol. Conf.*, 2020, pp. 1–3.
- [52] M. Schuld, I. Sinayskiy, and F. Petruccione, "The quest for a quantum neural network," *Quantum Inf. Process.*, vol. 13, no. 11, pp. 2567–2586, 2014.
- [53] M. Caleffi and A. S. Cacciapuoti, "Quantum switch for the quantum internet: Noiseless communications through noisy channels," *IEEE J. Sel. Areas Commun.*, vol. 38, no. 3, pp. 575–588, Mar. 2020.
- [54] S. Jeswal and S. Chakraverty, "Recent developments and applications in quantum neural network: A review," *Arch. Comput. Methods Eng.*, vol. 26, no. 4, pp. 793–807, 2019.
- [55] Z.-A. Jia, B. Yi, R. Zhai, Y.-C. Wu, G.-C. Guo, and G.-P. Guo, "Quantum neural network states: A brief review of methods and applications," *Adv. Quantum Technol.*, vol. 2, no. 7–8, 2019, Art. no. 1800077.
- [56] S. Choudhury, A. Dutta, and D. Ray, "Chaos and complexity from quantum neural network. a study with diffusion metric in machine learning," *J. High Energy Phys.*, vol. 2021, no. 4, pp. 1–33, 2021.
- [57] N. H. Nguyen, E. C. Behrman, M. A. Moustafa, and J. E. Steck, "Benchmarking neural networks for quantum computations," *IEEE Trans. Neural Netw. Learn. Syst.*, vol. 31, no. 7, pp. 2522–2531, Jul. 2020.
- [58] K. Beer et al., "Training deep quantum neural networks," *Nature Commun.*, vol. 11, no. 1, pp. 1–6, 2020.
- [59] C. Ding, T.-Y. Bao, and H.-L. Huang, "Quantum-inspired support vector machine," *IEEE Trans. Neural Netw. Learn. Syst.*, to be published, doi: 10.1109/TNNLS.2021.3084467.
- [60] R. Zhang, J. Wang, N. Jiang, H. Li, and Z. Wang, "Quantum support vector machine based on regularized Newton method," *Neural Netw.*, vol. 151, pp. 376–384, 2022.
- [61] H. Li, N. Jiang, R. Zhang, Z. Wang, and H. Wang, "Quantum support vector machine based on gradient descent," *Int. J. Theor. Phys.*, vol. 61, no. 3, pp. 1–12, 2022.
- [62] G. Singh et al., "Implementation of quantum support vector machine algorithm using a benchmarking dataset," *Indian J. Pure Appl. Phys.*, vol. 60, no. 5, pp. 407–414, 2022.
- [63] V. Bhatia and K. Ramkumar, "An efficient quantum computing technique for cracking RSA using Shor's algorithm," in *Proc. IEEE 5th Int. Conf. Comput. Commun. Automat.*, 2020, pp. 89–94.
- [64] Z. Cao and L. Liu, "On the complexity of Shor's algorithm for factorization," in *Proc. 2nd Int. Symp. Inf. Sci. Eng.*, 2009, pp. 164–168.

- [65] M. Rahman and G. Paul, "Grover on KATAN: Quantum resource estimation," *IEEE Trans. Quantum Eng.*, vol. 3, 2022, Art. no. 3100809.
- [66] A. Anshu, S. B. Hadiashar, R. Jain, A. Nayak, and D. Touchette, "One-shot quantum state redistribution and quantum Markov chains," in *Proc. IEEE Int. Symp. Inf. Theory*, 2021, pp. 130–135.
- [67] J. Shin, K. Yeon, S. Kim, M. Sunwoo, and M. Han, "Comparative study of Markov chain with recurrent neural network for short term velocity prediction implemented on an embedded system," *IEEE Access*, vol. 9, pp. 24755–24767, 2021.
- [68] I. Bardet, M. Junge, N. Laracuenta, C. Rouzé, and D. S. França, "Group transference techniques for the estimation of the decoherence times and capacities of quantum Markov semigroups," *IEEE Trans. Inf. Theory*, vol. 67, no. 5, pp. 2878–2909, May 2021.
- [69] V. I. Yukalov and D. Sornette, "Quantitative predictions in quantum decision theory," *IEEE Trans. Syst., Man, Cybern. Syst.*, vol. 48, no. 3, pp. 366–381, Mar. 2018.
- [70] A. P. Flitney and D. Abbott, "An introduction to quantum game theory," *Fluctuation Noise Lett.*, vol. 2, no. 04, pp. R175–R187, 2002.
- [71] W. Jiang, B. Han, M. A. Habibi, and H. D. Schotten, "The road towards 6G: A comprehensive survey," *IEEE Open J. Commun. Soc.*, vol. 2, pp. 334–366, 2021.
- [72] C. D. Alwis et al., "Survey on 6G frontiers: Trends, applications, requirements, technologies and future research," *IEEE Open J. Commun. Soc.*, vol. 2, pp. 836–886, 2021.
- [73] K. Ma, D. He, H. Sun, Z. Wang, and S. Chen, "Deep learning assisted calibrated beam training for millimeter-wave communication systems," *IEEE Trans. Commun.*, vol. 69, no. 10, pp. 6706–6721, Oct. 2021.
- [74] M. Fayaz, W. Yi, Y. Liu, and A. Nallanathan, "Transmit power pool design for grant-free NOMA-IoT networks via deep reinforcement learning," *IEEE Trans. Wireless Commun.*, vol. 20, no. 11, pp. 7626–7641, Nov. 2021.
- [75] L. K. Grover, "A fast quantum mechanical algorithm for database search," in *Proc. 28th Annu. ACM Symp. Theory Comput.*, 1996, pp. 212–219. [Online]. Available: <https://doi.org/10.1145/237814.237866>
- [76] P. Botsinis, S. X. Ng, and L. Hanzo, "Quantum search algorithms, quantum wireless, and a low-complexity maximum likelihood iterative quantum multi-user detector design," *IEEE Access*, vol. 1, pp. 94–122, 2013.
- [77] B. Narottama and T. Q. Duong, "Quantum neural networks for optimal resource allocation in cell-free MIMO systems," in *Proc. IEEE Glob. Commun. Conf.*, 2022, pp. 1–6.
- [78] B. Narottama, D. K. Hendraningrat, and S. Y. Shin, "Quantum-inspired evolutionary algorithms for NOMA user pairing," *ICT Express*, vol. 8, no. 1, pp. 11–17, 2022.
- [79] M. Dušek, N. Lütkenhaus, and M. Hendrych, "Quantum cryptography," *Prog. Opt.*, vol. 49, pp. 381–454, 2006.
- [80] V. Padamvathi, B. V. Vardhan, and A. Krishna, "Quantum cryptography and quantum key distribution protocols: A survey," in *Proc. IEEE 6th Int. Conf. Adv. Comput.*, 2016, pp. 556–562.
- [81] H. Zhang, Z. Ji, H. Wang, and W. Wu, "Survey on quantum information security," *China Commun.*, vol. 16, no. 10, pp. 1–36, 2019.
- [82] A. A. Saki, M. Alam, K. Phalak, A. Suresh, R. O. Topaloglu, and S. Ghosh, "A survey and tutorial on security and resilience of quantum computing," in *Proc. IEEE Eur. Test Symp.*, 2021, pp. 1–10.
- [83] R. Arul, G. Raja, A. O. Almagrabi, M. S. Alkathairi, S. H. Chauhdary, and A. K. Bashir, "A quantum-safe key hierarchy and dynamic security association for LTE/SAE in 5G scenario," *IEEE Trans. Ind. Inform.*, vol. 16, no. 1, pp. 681–690, Jan. 2020.
- [84] S. Kundu and S. Ghosh, "Security aspects of quantum machine learning: Opportunities, threats and defenses," in *Proc. Great Lakes Symp.*, 2022, pp. 463–468.
- [85] M. S. Sharbaf, "Quantum cryptography: A new generation of information technology security system," in *Proc. 6th Int. Conf. Inf. Technol.: New Gener.*, 2009, pp. 1644–1648.
- [86] M. S. Rahman and M. Hossam-E-Haider, "Quantum IoT: A quantum approach in IoT security maintenance," in *Proc. Int. Conf. Robot., Elect. Signal Process. Techn.*, 2019, pp. 269–272.
- [87] S. Nayak and R. Patgiri, "6G communication technology: A vision on intelligent healthcare," in *Health Informatics: A Computational Perspective in Healthcare*. Berlin, Germany: Springer, 2021, pp. 1–18.
- [88] Z. Lv, R. Lou, J. Li, A. K. Singh, and H. Song, "Big data analytics for 6G-enabled massive Internet of Things," *IEEE Internet Things J.*, vol. 8, no. 7, pp. 5350–5359, Apr. 2021.
- [89] S. A. Abdel Hakeem, H. H. Hussein, and H. Kim, "Security requirements and challenges of 6G technologies and applications," *Sensors*, vol. 22, no. 5, 2022, Art. no. 1969.
- [90] T. Pratt and J. E. Allnutt, *Satellite Communications*. Hoboken, NJ, USA: Wiley, 2019.
- [91] J. A. Ansere, G. Han, K. A. Bonsu, and Y. Peng, "Energy-efficient joint power allocation and user selection algorithm for data transmission in Internet-of-Things networks," *IEEE Internet Things J.*, vol. 7, no. 9, pp. 8736–8747, Sep. 2020.
- [92] J. A. Ansere, G. Han, and H. Wang, "A novel reliable adaptive beacon time synchronization algorithm for large-scale vehicular ad hoc networks," *IEEE Trans. Veh. Technol.*, vol. 68, no. 12, pp. 11565–11576, Dec. 2019.
- [93] A. Masaracchia et al., "UAV-enabled ultra-reliable low-latency communications for 6G: A comprehensive survey," *IEEE Access*, vol. 9, pp. 137338–137352, 2021.



TRUNG Q. DUONG (Fellow, IEEE) is a Chair Professor of Telecommunications with Queen's University Belfast, Belfast, U.K. He was a Lecturer (Assistant Professor) from 2013 to 2017, Reader (Associate Professor) from 2018 to 2020, and Full Professor from August 2020. He also holds the prestigious Research Chair of Royal Academy of Engineering. His research interests include wireless communications, machine learning, real-time optimisation, and data analytics. He is currently an Editor of the IEEE TRANSACTIONS ON WIRELESS

COMMUNICATIONS, IEEE TRANSACTIONS ON VEHICULAR TECHNOLOGY, IEEE WIRELESS COMMUNICATIONS LETTERS, and Executive Editor of IEEE COMMUNICATIONS LETTERS.



JAMES ADU ANSERE (Member, IEEE) received the B.Sc. degree in physics from the University of Cape Coast, Cape Coast, Ghana, in 2007, the M.Sc. degree in telecommunication engineering from the Blekinge Institute of Technology, Karlskrona, Sweden, in 2012, and the Ph.D. degree in information and communication engineering, from Hohai University, Nanjing, China, in 2021. He is currently a Lecturer with Sunyani Technical University, Sunyani, Ghana. His research interests include the Internet of Things, quantum, computing, reinforcement learning, green communications, and resource optimization networks.

Dr. Ansere was the recipient of the Sparbanksstiftelsen Kronan for Master's Thesis Award, Sweden, in 2012 and the Fellowship Award from the Civilian Institute of Democratic Administration, West Africa, in 2017.



BHASKARA NAROTTAMA (Student Member, IEEE) received the bachelor's degree in telecommunication engineering and the master's degree in electrical and telecommunication engineering from Telkom University, Bandung, Indonesia, in 2015 and 2017, respectively. He is currently working toward the Ph.D. degree with the Department of IT Convergence Engineering, Kumoh National Institute of Engineering, Gumi-si, South Korea. His research interests include quantum neural networks, quantum-inspired algorithms, non-orthogonal multiple access, ultra-reliable and low-latency communication, device-to-device communication, and energy-efficient communication.



VISHAL SHARMA (Senior Member, IEEE) received the B.Tech. degree in computer science and engineering from Punjab Technical University, Kapurthala, India, in 2012, and the Ph.D. degree in computer science and engineering from Thapar University, Patiala, India, in 2016. From November 2016 to March 2019, he was with the Information Security Engineering Department, Soonchunhyang University, Asan, South Korea, in multiple positions, such as from November 2016 to December 2017, he was a Postdoctoral Researcher, and from

January 2018 to March 2019, he was a Research Assistant Professor. He was also a joint Postdoctoral Researcher with Soongsil University, Seoul, South Korea. Before this, he was a Lecturer with the Department of Computer Science and Engineering, Thapar University. He is currently a Lecturer (Assistant Professor) with the School of Electronics, Electrical Engineering and Computer Science, Queen's University Belfast (QUB), Belfast, U.K., he is also a Racial Equity Network School Co-champion, BCS Accreditation Liaison, and Mental Health Ambassador. Before coming to QUB, he was a Research Fellow with the Information Systems Technology and Design Pillar, Singapore University of Technology and Design, Singapore, where he worked on the future-proof blockchain systems. He has authored or coauthored more than 100 journals/conference articles and book chapters and co-edited two books with Springer. His research interests include autonomous systems, UAV communications, network behavior modeling, 5G and beyond, blockchain, and CPS security. He is a Professional Member of ACM and the Past Chair of ACM Student Chapter-TIET Patiala. He was the recipient of four best paper awards. He is the Editorial Board of *IEEE Communications Magazine*, *CAAI Transactions on Intelligence Technology (IET)*, *Wireless Communications and Mobile Computing*, *IET Networks*, and *ICT Express*, and Section Editor-in-Chief of *Drones journal*. He is also the Interim Co-Chair of the IEEE U.K. and Ireland Diversity, Equity, and Inclusion Committee.



OCTAVIA A. DOBRE (Fellow, IEEE) received the Dipl.Ing. and Ph.D. degrees from the Polytechnic Institute of Bucharest, Bucharest, Romania, in 1991 and 2000, respectively. Between 2002 and 2005, she was with the New Jersey Institute of Technology, Newark, NJ, USA. In 2005, she joined Memorial University, St. John's, NL, Canada, where she is currently a Professor and Research Chair. She was a Visiting Professor with the Massachusetts Institute of Technology, Cambridge, MA, USA, and Universite de Bretagne Occidentale, Brest, France. She has authored or coauthored more than 400 refereed papers in his research areas, which include wireless communication and networking technologies, and optical and underwater communications. Dr. Dobre is the Director of Journals of the Communications Society. She was the Inaugural Editor-in-Chief of the IEEE Open Journal of the Communications Society, Editor-in-Chief of IEEE COMMUNICATIONS LETTERS, Senior Editor, Editor, and Guest Editor of various prestigious journals and magazines. Dr. Dobre was a Fulbright Scholar, Royal Society Scholar, and Distinguished Lecturer of the IEEE Communications Society. She was the recipient of the Best Paper Awards at various conferences, including IEEE ICC, IEEE Globecom, IEEE WCNC, and IEEE PIMRC. Dr. Dobre is an Elected Member of the European Academy of Sciences and Arts, a Fellow of the Engineering Institute of Canada, and Fellow of the Canadian Academy of Engineering.



HYUNDONG SHIN (Fellow, IEEE) received the B.S. degree in electronics engineering from Kyung Hee University (KHU), Yongin-si, South Korea, in 1999, and the M.S. and Ph.D. degrees in electrical engineering from Seoul National University, Seoul, South Korea, in 2001 and 2004, respectively. During his Postdoctoral Research with the Massachusetts Institute of Technology, Cambridge, MA, USA, from 2004 to 2006, he was with the Wireless Communication and Network Sciences Laboratory within the Laboratory for Information

Decision Systems. In 2006, he joined the KHU, where he is currently a Professor with the Department of Electronic Engineering and Department of Electronics and Information Convergence Engineering. His research interests include quantum information science, wireless communication, and machine intelligence. Dr. Shin was honored with the Knowledge Creation Award in the field of Computer Science from Korean Ministry of Education, Science and Technology in 2010. He was the recipient of the IEEE Communications Society's Guglielmo Marconi Prize Paper Award in 2008 and William R. Bennett Prize Paper Award in 2012. He was the Publicity Co-chair of the IEEE PIMRC in 2018 and Technical Program Co-chair of the IEEE WCNC (PHY Track 2009) and IEEE Globecom (Communication Theory Symposium 2012, Cognitive Radio and Networks Symposium 2016). He was the Editor of IEEE TRANSACTIONS ON WIRELESS COMMUNICATIONS (during 2007-2012) and IEEE COMMUNICATIONS LETTERS (during 2013-2015).