

## SYSTEM IDENTIFICATION OF CLASSIC HVDC SYSTEMS

L. Chetty\* and N.M. Ijumba\*\*

\*HVDC Centre, University of KwaZulu Natal, Private Bag X54001, 4001, South Africa

E-mail: [chettyl2@ukzn.ac.za](mailto:chettyl2@ukzn.ac.za)

\*\* HVDC Centre, University of KwaZulu Natal, Private Bag X54001, 4001, South Africa

E-mail: [ijumban@ukzn.ac.za](mailto:ijumban@ukzn.ac.za)

**Abstract:** Determining models from observations and studying the models' properties is essentially the functionality of science. Models attempt to link observations into some pattern. System identification is the art of building mathematical models of dynamic systems based on observed data from the systems. This paper presents a system identification methodology that can be utilized to derive the classic HVDC plant transfer functions. The model development and verification was performed using the PSCAD/EMTDC software. The calculated results illustrated excellent response matching with the system results. The derived HVDC plant transfer functions can be utilized to perform small signal stability studies of HVDC-HVAC interactions and its use can also be extended to facilitate the analytical design of HVDC control systems.

**Key words:** HVDC transmission control, modelling, simulation, uncertainty

### 1. INTRODUCTION

From the early days of HVDC system applications, the importance of mathematical modelling of HVDC systems has been appreciated [1-10]. Mathematical models of HVDC systems can be utilized to quantitatively analysis HVDC operation issues which include second harmonic instability and problems related to low short circuit capacity of ac systems connected to dc systems [1,4,8]. A mathematical model of an HVDC system can also be utilized for the design synthesis of HVDC control systems [3].

There are essentially two methodologies used to develop mathematical models of dynamic systems. One methodology is to figuratively divide the system into subsystems. The properties of each subsystem are defined by the "laws of nature" and other well-established relationships [18]. These subsystems are mathematically consummated to formulate a model of the original system. Basic techniques of this methodology involve describing the system's processes using block diagrams. This methodology is called "White Box Modelling" [18].

The other methodology used to derive mathematical models of a dynamic system is based on experimentation [18]. Input and output signals from the original system are recorded to infer a mathematical model of the system. This methodology is known as "System Identification" [18].

### 2. MODELLING OF CLASSIC HVDC SYSTEMS: STATE OF THE ART

Traditionally classic HVDC systems have been treated as "linear time invariant systems" [3-11]. Based on this premise, Persson [3] developed a meshed block diagram, illustrated in Figure 1, to calculate the current control loop plant transfer function. The transfer functions of

each block in the meshed system were derived using the state variable approach. The transfer functions describing the ac and dc interactions were derived using describing function analysis. Persson [3] called these transfer functions "conversion functions".

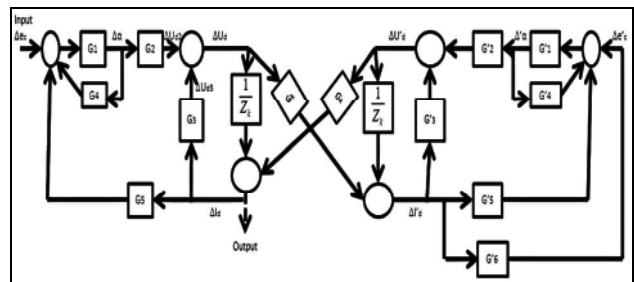

Figure 1: Block diagram of HVDC transmission system according to [3]

Based on the assumption that the classic HVDC system is linear with regard to small variations in the firing angle, Freris et al. [4] developed a block diagram, illustrated in Figure 2, to calculate the transfer function of the rectifier current control loop. Continuous wave modulation and Fourier analysis were used to determine the transfer functions of each block in the meshed block diagram. The continuous wave modulation technique was used as a method of developing the describing functions to account for the ac/dc interactions.

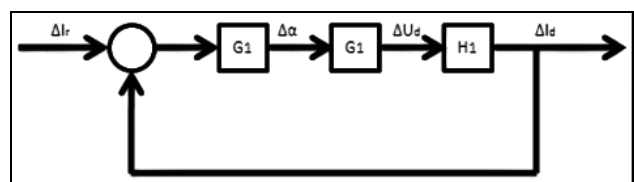

Figure 2: Block diagram of HVDC transmission system according to [4]

From the linear time invariant system foundation, Wood et al. [5] performed Fourier analysis on the dc voltage and

ac current waveforms of the converter. From these analyses, transfer functions were obtained for the dc voltage and ac currents with respect to the phase voltages and dc currents. These transfer functions accommodated variations in the firing angle and the commutation period. The subsequent transfer functions facilitated the predictions of voltage waveform distortion on the dc side of the converter, and the prediction of current waveform distortion on the ac side of the converter. Using the transfer functions derived in [5], Wood et al. [6] developed an expression for the converter dc side frequency dependent impedance. This expression was developed using the state-variable approach. Using the state-variable approach and the frequency dependent impedance of the converter, Wood et al [7] derived the transfer function for the current control loop.

Jovic et al. [8], assumed that classic HVDC systems are linear time invariant systems, therefore developed the plant transfer function of the current control loop using a state-variable approach and the block diagram illustrated in Figure 3.

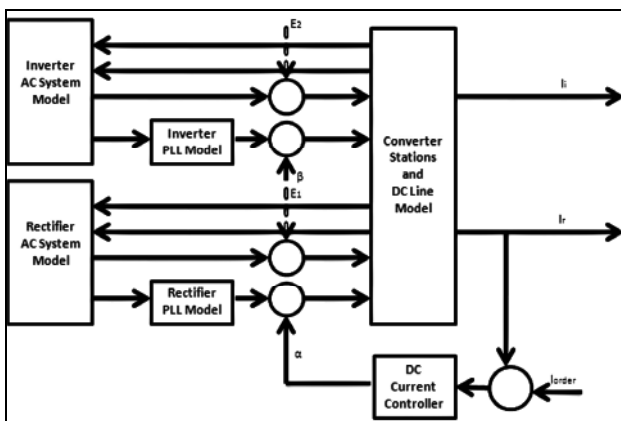

Figure 3: Block diagram of HVDC transmission system according to [5]

The state variables were chosen to be the instantaneous values of currents in the inductors and voltages across the capacitors. In order to represent the ac system dynamics together with the dc system dynamics in the same frequency frame, the effect of the frequency conversion through the AC-DC converter was accommodated using Park's transformation. The developed system model was linearized around the normal operating point, and all states were represented as dq components of the corresponding variables. The phase locked oscillator was incorporated into the system model.

A review of the current state of the art of modelling classic HVDC systems clearly indicates that the techniques utilized to develop mathematical models of classic HVDC systems have used the "White Box Modelling" methodology. This methodology requires accurate knowledge of the ac systems and the dc systems and involves complicated mathematics.

In practice, it is nearly impossible to obtain accurate knowledge of the ac systems connected to classic HVDC systems.

Also the limited time constraints imposed on HVDC control practitioners, the ac system uncertainties and the complicated mathematics have prevented the widespread practical use of the "White Box Modelling" methodology to derive the plant transfer functions of classic HVDC systems. The objective of this study was to utilize the "System Identification" methodology to derive mathematical models of the classic HVDC systems.

### 3. SYSTEM IDENTIFICATION METHODOLOGY

System identification is the art of building mathematical models of dynamic systems based on observed data from the systems [18]. A key concept in utilizing the system identification is the definition of the dynamic system upon which experimentation can be conducted. Manitoba HVDC Research Centre commissioned a study to examine the validity of digitally defining the classic HVDC system [19-20]. To examine the validity of digitally defining the classic HVDC system, the Nelson River HVDC system was defined and simulated using the EMTDC program. EMTDC is a FORTRAN program and was used to represent and solve the linear and non-linear differential equations of electromagnetic systems in the time domain. A comparison was conducted between the actual real-time system responses and the digitally derived responses. The results of the study illustrated that the digitally derived responses correlated excellently with the real system responses. The study concluded that the EMTDC program is a valid option for digitally defining a classic HVDC system [19-20].

Therefore in this study, the classic HVDC system will be defined and experimented upon using the PSCAD/EMTDC program. PSCAD is a graphical user interface that easily assisted in defining the classic HVDC systems' linear and non-linear differential equations in EMTDC.

#### 3.1 Jacobian Linearization

Consider a non-linear system defined by the following differential equation:

$$\frac{dx}{dt} = f(x) + g(x)u \quad (1)$$

$$y = h(x) \quad (2)$$

Where

$x$  = the state variable vector  
 $u$  = the input vector  
 $y$  = the output vector

The Jacobian linearization of the above non-linear system at a stable operating point  $(u_o, x_o, y_o)$  is defined as

$$\frac{dx}{dt} = \left[ \frac{\partial f(x_o)}{\partial x} + \frac{\partial g(x_o)}{\partial x} u_o \right] (x - x_o) + g(x_o)(u - u_o) \quad (3)$$

$$y - y_o = \frac{\partial h(x_o)}{\partial x} (x - x_o) \quad (4)$$

Equations (3) and (4) can be written in standard linear state space representation as [14]:

$$\frac{dx}{dt} = Ax + Bu \quad (5)$$

$$y = Cx \quad (6)$$

Where

A, B, C = constant matrices

The model described by equations (5) and (6) is a linear approximation of the original non-linear system, described by equations (1) and (2), around the stable operating point  $(u_o, x_o, y_o)$ . This implies that original non-linear system can be linearized if it can be construed to function around a normal stable operating point.

The above fact is exploited in this study. The classic HVDC system was simulated in PSCAD/EMTDC to reach a normal steady-state operating point. The classic HVDC system is considered linearized around the normal steady-state operating point. Therefore a classic HVDC system can be considered as “linear time invariant system” around the stable operating point. The impulse response of a “linear time invariant system” is determined by first determining the step response and then exploiting the fact that the impulse response is obtained by differentiating the step response [16]. The Laplace transform of the impulse response is defined as the transfer function of the “linear time-invariant system” [16]. The plant transfer function can be explicitly obtained by determining the ratio of the Laplace transform of the step response to the Laplace transform of the step input [16].

This implies that the small signal plant transfer function of a classic HVDC system can be obtained by determining the ratio of the Laplace transform of the small signal step response of the classic HVDC system to the Laplace transform of the step input of the rectifier firing angle or inverter firing angle.

There are 2 definitive modes of operation of the classic HVDC system, which are explicitly described as [17]:

1. Rectifier in Current Control and the Inverter in Voltage Control
2. Rectifier in Voltage Control and the Inverter in Current Control

Therefore in the next sections, methodologies utilized to derive the Rectifier Current Control transfer function and Inverter Current Control transfer function will be defined.

### 3.2 Rectifier Current Control Plant Transfer Function

The classic HVDC system, shown in Figure 4, was modelled in PSCAD/EMTDC.

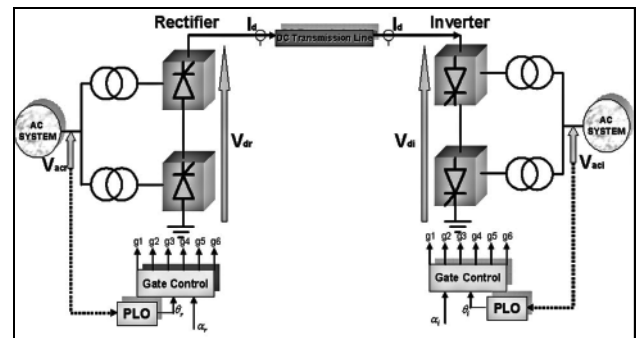

Figure 4: Simulated Feed-Forward Controlled Classic HVDC System

The system was simulated so that it reached steady-state. At which point a snap shot of system variables was recorded. The inverter firing angle was then kept constant. A feed-forward step increase in the rectifier firing angle  $\alpha_r$ , was executed and the dc current response  $I_{dr}$  was measured and is illustrated Figure 5.

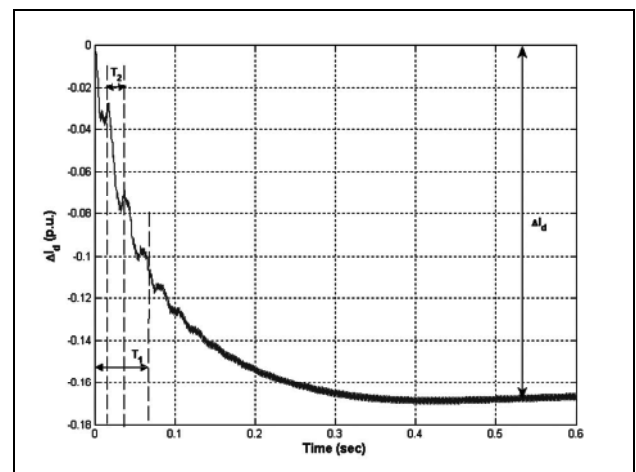

Figure 5: Measured DC Current Response

The measured current response was approximated using the time domain function illustrated in equation (7):

$$\Delta I_{dr}(t) = \begin{cases} 0 & t < T_d \\ \Delta I_d (1 - e^{-at} + k|\Delta I_d| e^{-at} \cdot \sin(\omega t)) & t \geq T_d \end{cases} \quad (7)$$

Where:

$T_d$  = the time delay (sec)

$\Delta I_d$  = the change in the dc current (p.u.)

$k$  = constant ( $0 < k \leq 1$ ); chosen to be 0.25

And:

$$a = \frac{1}{T_1} \quad (8)$$

$$\omega = \frac{2\pi}{T_2} \quad (9)$$

Where:

$T_1$  = the time (sec) it takes the decaying waveform to reach  $e^{-1}$  of its final value.

$T_2$  = the period (sec) of the superimposed as ac waveform.

The function described by equation (7) is called the *HVDC Step Response (HSR) equation* and was simulated using MATLAB and the characteristic time domain response is illustrated in Figure 6, together with the associated error when compared to the original signal.

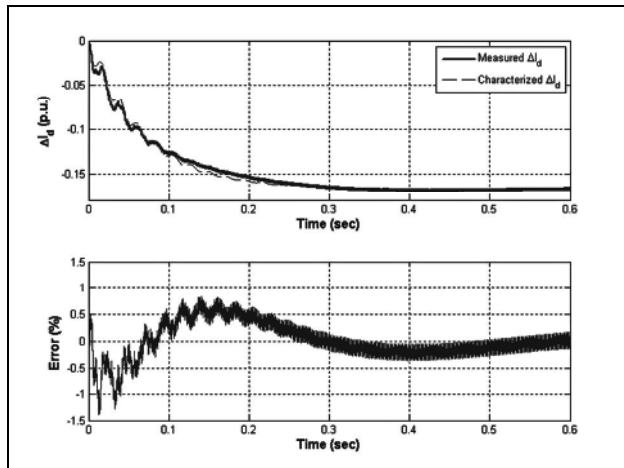

Figure 6: Characterized DC Current Response

Figure 6 clearly illustrates that the *HSR equation* adequately approximates the dc current response to a step change in the rectifier’s firing angle since the resultant error does not exceed 1.5%.

Equation (7) was used to calculate the rectifier current control plant transfer function. The resultant rectifier current control plant transfer function is illustrated in the equation (10):

$$P_{cr}(s) = \frac{\Delta I_{dr}}{\Delta \alpha_r} e^{-sT_d} \left( \frac{s^3 + (3a-1)s^2 + (3a^2 - 2a + \omega^2 + k|\Delta I_d|\omega)s + (a^3 - a^2 + a\omega^2 - \omega^2 + k|\Delta I_d|a\omega)}{(s+a)(s^2 + 2as + a^2 + \omega^2)} \right) \quad (10)$$

### 3.3 Inverter Current Control Plant Transfer Function

The classic HVDC system, shown in Figure 4, was modelled in PSCAD/EMTDC. The classic HVDC system was simulated so that it reached steady-state. At which point a snap shot of system variables was recorded. The rectifier firing angle was then kept constant. A feed-forward step decrease in the inverter firing angle  $\alpha_i$  was executed and the dc current response  $I_{di}$  was measured and is illustrated Figure 7.

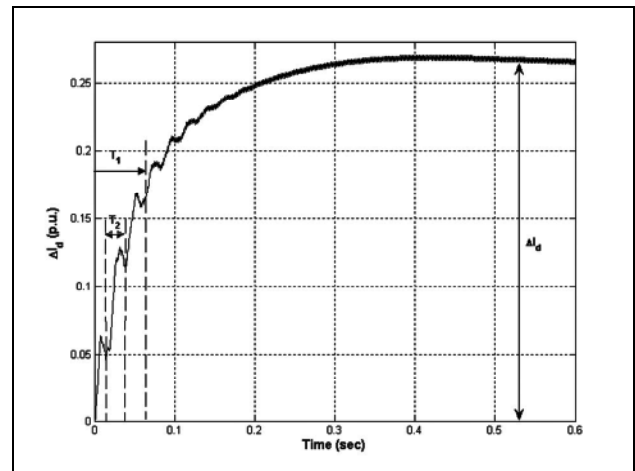

Figure 7: Measured DC Current Response

The measured current response was approximated using the *HVDC Step Response (HSR) equation* as described in equation (11):

$$\Delta I_{di}(t) = \begin{cases} 0 & t < T_d \\ \Delta I_d (1 - e^{-at} + k|\Delta I_d| e^{-at} \cdot \sin(\omega t)) & t \geq T_d \end{cases} \quad (11)$$

The HSR equation was again simulated using MATLAB and characteristic time domain response is illustrated in Figure 8, together with the associated error when compared to the original signal.

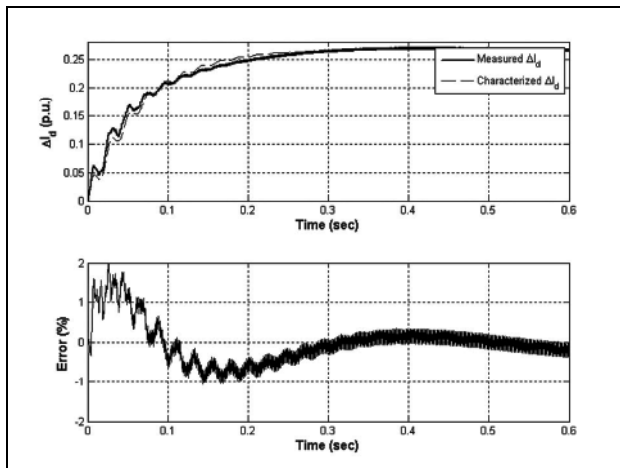

Figure 8: Characterized DC Current Response

Figure 8 clearly illustrates that the *HSR equation* adequately approximates the dc response to a step change in the inverter's firing angle since the resultant error does not exceed 2.0%. Equation (9) was used to calculate the inverter current control plant transfer function. The resultant inverter current control plant transfer function is illustrated below:

$$P_{ci}(s) = \frac{\Delta I_{di} e^{-T_d s}}{\Delta \alpha_i} \left( \frac{s^3 + (3\alpha - 1)s^2 + (3\alpha^2 - 2\alpha + w^2 + k|\Delta I_{di}|w)s + (a^3 - a^2 + aw^2 - w^2 + k|\Delta I_{di}|aw)}{(s+a)(s^2 + 2as + a^2 + w^2)} \right) \quad (12)$$

#### 4. CLASSIC HVDC PLANT UNCERTAINTY

The state of power systems change with sudden disturbances in the power system. These sudden disturbances will change the short circuit capacity of ac busbars in the power system. The factors defining the quantitative change in short circuit capacity are loss of generation, restoration of generation, loss of transmission, loss of demand and loss of reactive compensation.

Due to the diverse nature of the factors affecting the quantitative change in short circuit capacity of an ac busbar implies that the short circuit capacity at a given HVDC converter ac busbar will vary within a range. Therefore combined with the varying amount of dc power that will be transmitted on the HVDC transmission system, the effective short circuit ratio (ESCR) for a given HVDC converter station will vary within a certain range.

Due to the uncertain nature of the effective short circuit ratio of rectifier and inverter converter stations, the plant transfer functions developed in the previous section will have a range of uncertainty. The objective of this section of the paper will be to present the plant transfer function parametric ranges for varying short circuit ratios.

The methodologies used to calculate the parametric variations in the plant transfer functions were exactly the same as the methodologies presented in the previous

section, with the only exception being that the effective short circuit ratios were varied.

In this study, the Thévenin's equivalent ac network impedances were represented using a pure inductance. This implies that the network resistance is assumed to be zero and the "damping angle" was taken as 90°. Kundur [3] states that while local resistive loads do not have a significant effect on the ESCR, these resistive loads do improve the damping of the system thereby improving the dynamic performance of the control system. By assuming the resistive element of the Thevenin's equivalent network to be zero, the worst case (from a dynamic stability perspective) was simulated and analysed.

Kundur [3] states that the dynamic performance of a current controller is dependent on the strength of both the rectifier and inverter ac systems. Therefore the variations of the parameters of the rectifier current control plant transfer function and the inverter current control plant transfer function were calculated for variations in the rectifier converter station's and the inverter converter station's effective short circuit ratios.

When the rectifier converter station's ESCR varies from 2.83 to 7.96 and the inverter converter station's ESCR varies from 3.93 to 7.96, the variations in the rectifier current control plant transfer function parameters were determined and the results are illustrated in Figure 9 and Table 1.

Inverter	Rectifier	Parameters					
		$\Delta I_{\phi}$	$a$	$w$	$T_d$	$\Delta \alpha_r$	$k_{\omega}$
7.96	7.96	-0.17	14.95	290.89	0.70	10.00	-0.017
7.96	6.24	-0.16	20.54	285.60	0.80	10.00	-0.016
7.96	4.50	-0.14	31.51	279.25	1.00	10.00	-0.014
7.96	2.77	-0.10	44.23	239.82	1.65	10.00	-0.010
5.97	8.03	-0.18	12.38	278.02	0.63	10.00	-0.018
5.97	6.30	-0.17	14.73	285.60	0.81	10.00	-0.017
5.97	4.54	-0.15	21.39	272.00	1.08	10.00	-0.015
5.97	2.79	-0.10	43.20	240.74	1.65	10.00	-0.010
3.93	8.18	-0.24	7.12	265.11	0.60	10.00	-0.024
3.93	6.43	-0.22	8.40	262.89	0.76	10.00	-0.022
3.93	4.64	-0.18	13.62	254.38	0.99	10.00	-0.018
3.93	2.83	-0.11	35.71	216.66	1.59	10.00	-0.011

Table 1: Parametric Variations of Rectifier Current Control Plant Transfer Function for Varying ESCRs

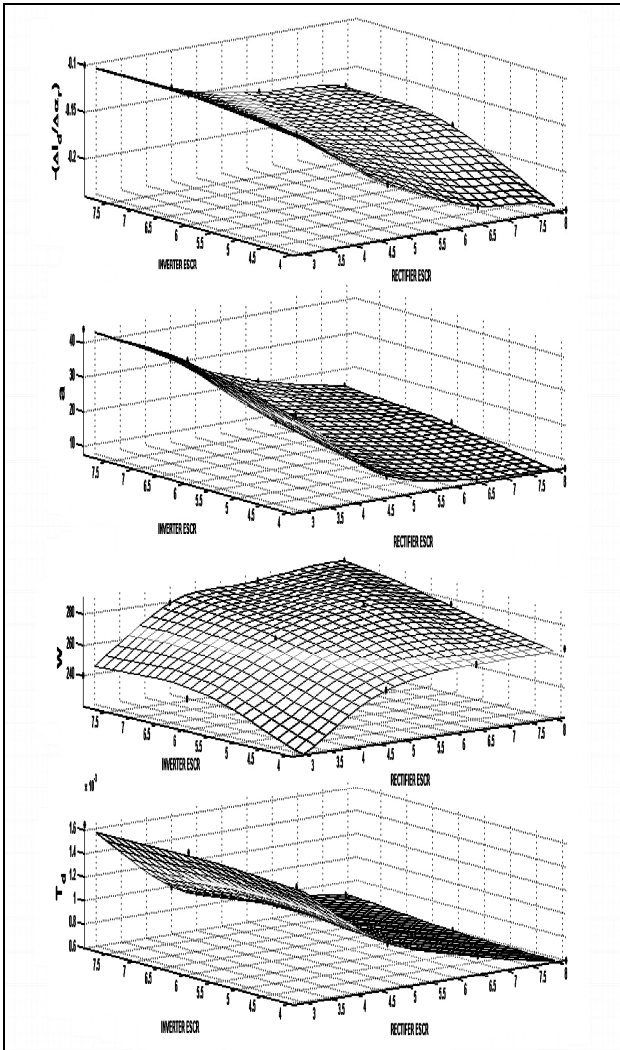

Figure 9: Rectifier Current Control Plant Transfer Function Parametric Variations

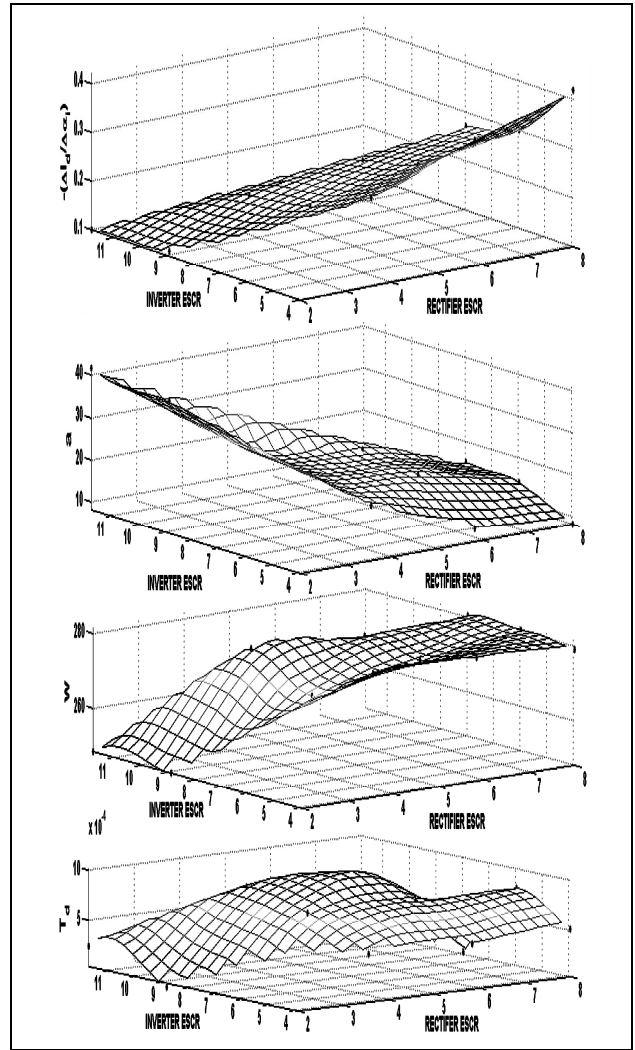

Figure 10: Inverter Current Control Plant Transfer Function Parametric Variations

When the rectifier converter station’s ESCR varies from 4 to 8 and the inverter converter station’s ESCR varies from 3.94 to 11.8, the variations in the inverter current control plant transfer function parameters were determined and the results are illustrated in Figure 10 and Table 2.

From the above presented results, it can easily be identified that if the range of the ac system’s effective short circuit ratio is known, the range of parametric uncertainty of the classic HVDC plant transfer functions can be obtained.

5. DISCUSSION

The current state of the art of developing mathematical models of classic HVDC systems has been to utilize the “White Box Modelling” methodology. This paper presents a “System Identification” methodology to derive the plant transfer functions of classic HVDC systems. The classic HVDC system linear and non-linear differential equations were modelled in PSCAD/EMTDC. For small changes in the rectifier’s firing angle, the rectifier’s current control loop can be linearized around a stable (or equilibrium) operation point. This is defined as the “Jacobian Linearization” of the original non-linear current control loop. PSCAD/EMTDC was used to obtain the dc current step response of a classic HVDC system. The measured current response was approximated using the time domain function defined as *HVDC Step*

Inverter ESCR	Rectifier ESCR	Parameters					
		$\Delta_{ai}$	$a$	$w$	$T_d$	$\Delta\alpha_i$	$k_{cc}$
7.96	8	0.27	15.19	280.50	0.06	-5.00	-0.053
8.4335	6	0.23	21.12	278.02	0.89	-5.00	-0.046
9.29	4	0.18	23.80	276.79	0.86	-5.00	-0.036
11.8	2	0.10	41.63	248.35	0.24	-5.00	-0.020
5.97	8	0.30	14.27	280.50	0.81	-5.00	-0.061
6.34	6	0.26	19.31	275.58	0.78	-5.00	-0.052
6.99	4	0.20	22.16	268.51	0.73	-5.00	-0.041
8.87	2	0.11	39.62	248.35	0.00	-5.00	-0.021
3.94	8	0.42	8.31	279.25	0.51	-5.00	-0.084
4.2112	6	0.35	10.67	280.50	0.46	-5.00	-0.071
4.69	4	0.26	19.16	279.25	0.45	-5.00	-0.052

Table 2: Parametric Variations of Inverter Current Control Plant Transfer Function for Varying ESCRs

*Response (HSR) equation.* The results validated that *HSR equation* adequately approximated the dc current response to a step change in the rectifier's and inverter's firing angle since the resultant error was very minimal. The Laplace transform of the characterized dc current response and the firing angle step input were determined and subsequent ratio of these Laplace transformations produce the HVDC Rectifier and Inverter Current Control Plant transfer functions. Due to the uncertain nature of the state of power systems, the parameters of the plant transfer functions that define the classic HVDC systems vary. The range of plant transfer function parametric variations was determined as a function of ac systems effective short circuit ratio. Therefore if the range of the ac system's effective short circuit ratio is known, the range of parametric uncertainty of the classic HVDC plant transfer functions can be obtained.

## 6. REFERENCES

- [1] K. Eriksson, G. Liss, E.V. Persson: "Stability Analysis of the HVDC Control System Transmission Using Theoretically Calculated Nyquist Diagrams", *IEEE Transactions on Power Apparatus and Systems*, Vol. PAS-89, No.5/6, pp. 733-740, June 1970.
- [2] E. Rumpf and S. Ranade: "Comparison of Suitable Control Systems for HVDC Stations connected to Weak AC Systems Part1: New Control Systems", *IEEE Transactions on Power Apparatus and Systems*, Vol. PAS-91, No.2, pp. 549-555, March 1972.
- [3] E.V. Persson: "Calculation of transfer functions in grid-controlled converter systems", *IEE Proceedings* Vol. 117, No.5, pp. 989-997, May 1970.
- [4] J.P. Sucena-Paiva and L.L. Freris: "Stability of a dc transmission link between weak ac systems", *IEE Proceedings*, Vol. 121, No. 6, pp. 508-515, June 1974.
- [5] A.R. Wood and J. Arrillaga: "HVDC converter waveform distortion: a frequency domain analysis", *IEE Proceedings*, Vol.142, No.1, pp. 88-96, January 1995.
- [6] A.R. Wood and J. Arrillaga: "Composite resonance; a circuit approach to the waveform distortion dynamics of an HVDC converter", *IEEE Transactions on Power Delivery*, Vol.10, No.4, pp. 1882-1888, October 1995.
- [7] A.R. Wood and J. Arrillaga: "The frequency dependent impedance of an HVDC converter", *IEEE Transactions on Power Delivery*, Vol.10, No.3, pp. 1635-1641, July 1995.
- [8] D. Jovcic, N. Pahalawaththa, M. Zavaahir: "Analytical modelling of HVDC-HVAC systems", *IEEE Transactions on Power Delivery*, Vol. 14, No. 2, pp. 506-501, April 1998.
- [9] D. Jovcic, N. Pahalawaththa, M. Zavaahir: "Stability analysis of HVDC control loops", *IEE Proceedings - Generation, Transmission and Distribution*, Vol. 146, No. 2, pp. 143-148, March 1998.
- [10] M. Aten, K.M. Abbott, N. Jenkins: "Developments in modelling and analysis of HVDC control systems", *Proceedings of European Power Electronics and Applications Conference*, Graz, 2001.
- [11] A.H.M.A. Rahim and E.P. Nowicki: "A Robust Damping Controller for an HV-ACDC System using a Loop-Shaping Procedure", *Journal of Electrical Engineering*, Vol. 56, No.1-2, pp. 15-20, 2005.
- [12] J. Karlsson: *Simplified Control Model for HVDC Classic*, MSc. Thesis, Royal Institute of Technology, Stockholm, 2006
- [13] Manitoba HVDC Research Centre Inc.: *PSCAD/EMTDC 4.2 User's Manual*, 2005
- [14] Packard, Poola, Horowitz: "Dynamic Systems and Feedback" Class Notes for ME132, University of California, 2002
- [15] IEEE/CIGRE Joint Task Force: "Definition and Classification on Power System Stability" *IEEE Transactions on Power Systems*, Vol. 19, No. 2, pp. 1387-1401, May 2004.
- [16] S. Haykin and B. van Veen; *Signals and Systems*, John Wiley & Sons, 2001
- [17] P. Kundur: *Power System Stability and Control*, ISBN 0-07-035958-X, McGraw-Hill, 1994
- [18] L. Ljung: *System Identification - Theory for the User*. Prentice-Hall, USA, 2nd edition, 1999.
- [19] D.A. Woodford: "Validation of Digital Simulation of DC Links" *IEEE Transactions on Power Apparatus and Systems*, PAS-104, No. 9, pp. 2588-2596, September 1985.
- [20] T. Ino, R.M. Mathur, M.R. Iravani and S. Sasaki: "Validation of Digital Simulation of DC Links - Part II", *IEEE Transactions on Power Apparatus and Systems*, Vol. PAS-104, No. 9, pp. 2596-2602, September 1985.

