

Toward More Electric Powertrains in Aircraft: Technical Challenges and Advancements

Joseph Benzaquen, *Member, IEEE*, JiangBiao He, *Senior Member, IEEE*,
and Behrooz Mirafzal, *Senior Member, IEEE*

Abstract—The main purpose of this article is to provide an instructive review of the technological challenges hindering the road toward more electric powertrains in aircraft. Hybrid, all-electric, and turboelectric powertrain architectures are discussed as possible fuel consumption and weight reduction solutions. Among these architectures, the short-term implementation of hybrid and all-electric architectures is limited, particularly for large-capacity aircraft due to the low energy/power density levels achievable by state-of-the-art electrical energy storage systems. Conversely, turboelectric architectures with advanced distributed propulsion and boundary layer ingestion are set to lead the efforts toward more electric powertrains. At the center of this transition, power converters and high-power density electric machines, i.e., electric motors and generators, and their corresponding thermal management systems are analyzed as the key devices enabling the more electric powertrain. Moreover, to further increase the fuel efficiency and power density of the aircraft, the benefits and challenges of implementing higher voltage powertrains are described. Lastly, based on the findings collected in this article, the projected roadmap toward more electric aircraft powertrains is presented. Herein, the individual targets for each technology, i.e., batteries, electric machines, and power converters, and how they translate to future aircraft prototypes are illustrated.

Index Terms—All-electric aircraft, hybrid aircraft, powertrain, power converters, electric machines, efficiency, power density.

I. INTRODUCTION

MODERN aerospace systems are shifting toward more electrification technologies to reduce fuel burn and emissions while lowering operational costs to satisfy market demands. Approximately 2-2.5% of the global greenhouse gas emissions are generated by the aviation industry, 90% of which are generated by commercial aircraft operations [1]. With this in mind, the aerospace industry has initiated a technological transition toward electrification with the so-called More Electric Aircraft (MEA) [2]. This more-electric design has been proven to reduce the fuel consumption of the aircraft by up to 9% by replacing mechanical, pneumatic, and hydraulic energy

sources with electric energy [3].

The MEA concept became a commercial reality in 2005 with the Airbus A380, followed by the Boeing 787. Among these two MEA, the 787 leads in installed electric power with 1-MW of onboard power [4]. Four 250-kW variable-speed generators directly driven by the jet engines are combined to achieve this power level, forming a constant-voltage/variable-frequency ac-bus. The Boeing 787 offered a 50% reduction of the mechanical system complexity by utilizing this variable-frequency technology compared to the Boeing 767 [5]. In addition, the mean time between failures (MTBF) value, as defined in [6], reached a 300% increment from the Boeing 767 to the 787. Despite the extraordinary improvements achieved by the MEA technology, future national and global subsonic airliner performance goals, e.g., 2020-2030 NASA and the European Commission in the Flightpath 2050, are demanding 40-70% fuel burn reduction with a 75% CO₂ emission decrease [7]. In light of this and considering that almost 90% of the aircraft's fuel is utilized for propulsion [8], the aerospace industry has started exploring more electric powertrain architectures that can further reduce fuel consumption and emissions [1].

As a first step toward more electric powertrains in aircraft, the National Academies of Sciences, Engineering, and Medicine's Committee on Propulsion and Energy Systems to Reduce Commercial Aviation Carbon Emissions [1] has investigated hybrid and turboelectric powertrain architectures for aircraft, which can potentially aid in the transition from more to all-electric aircraft. This transition is envisioned by the authors of [1] to be analogous to the evolution from hybrid-electric vehicles (HEV) to all-electric vehicles (EV), where HEVs carried the torch from classic fuel-based vehicles to EVs for almost 10 years [9]–[12]. Nonetheless, compared to the automotive industry, the aerospace industry requires electrical apparatuses with higher power levels, energy density, power density, and most importantly, any device onboard an aircraft must operate with maximum reliability under wide variations of altitude, temperature, and air pressure [13].

Several authors have recently documented some of the recent advances and state-of-the-art technologies for MEA. Many of the works have been presented as review papers focusing on specific aspects of the MEA and its future challenges. In [14], the authors focus on the main optimization efforts in the field of industrial electronics and energy conversion in MEA by highlighting the onboard power system integration trends. Similarly, in [15], the authors describe an

Manuscript received May 14, 2021; revised July 20, 2021; accepted August 24, 2021. date of publication September 25, 2021; date of current version September 18, 2021.

Joseph Benzaquen is with the School of Electrical and Computer Engineering, Georgia Institute of Technology, Atlanta, GA 30332. (e-mail: jbenzaquen3@gatech.edu).

JiangBiao He is University of Kentucky, Lexington, KY 40506 (e-mail: jiangbiao@ieee.org). (*Corresponding Author*)

Behrooz Mirafzal is Electrical and Computer Engineering Department, Kansas State University, Manhattan, KS 66506 USA (e-mail: mirafzal@ksu.edu).

Digital Object Identifier 10.30941/CESTEMS.2021.00022

MEA power system and its associated loads while also drawing attention to the importance of power electronics as the enabling technology for MEA. A more specific analysis of the challenges in the MEA technology, as well as its future trends, is presented in [2]. Conversely, an overview of the electric motor technologies used in MEA is provided in [16]. While in [17], the authors focus on the electric power generation in an MEA. In more recent works, such as [8], the authors introduce some of the powertrain architectures described in [1], focusing on large electric machines for all-electric and hybrid aircraft propulsion. Onboard microgrids in MEA are reviewed in [18], whereas the onboard energy storage for all-electric and hybrid aircraft is investigated in [19]. Lastly, in [20], the authors explore the possible future implementation of wide-bandgap devices for electrified transportation. More specifically, the article reviews the implementation of Gallium Nitride High Electron Mobility Transistors (GaN HEMTs) in electric vehicles, ships, rail vehicles, and aircraft.

The previous works provide a general or subsystem specific description of the challenges and trends in MEA. Although some of these articles introduce a brief outlook, none of them comprehensively instigates the challenges and technological requirements that can enable all-electric and hybrid aircraft powertrain architectures, focusing on the requirements and advancements of power converters and electric machines which act as the main technology enablers. In this article, the technological challenges hindering the path toward more electric powertrains are uncovered and thoroughly analyzed. More importantly, this paper focuses on the role of power converters, high-power-density electric machines, and higher voltage dc systems in this technological transition.

In addition to this introduction section, this paper contains five sections. Section II discusses the state-of-the-art aircraft powertrain architectures, and their challenges. Section III describes the requirements and challenges in electric machines (i.e., motors and generators) and their thermal management systems for aircraft applications. Similarly, Section IV discusses the state-of-the-art power converters for aircraft powertrains, as well as the benefits and challenges of higher voltage powertrains as part of the possible enabling technologies to achieve increased fuel efficiency and power density. Section V outlines the projected roadmap toward more electric aircraft powertrains. Finally, conclusions are drawn and summarized in Section VI.

II. MORE ELECTRIC AIRCRAFT POWERTRAIN ARCHITECTURES

The main block diagram of an aircraft propulsion system is depicted in Fig. 1(a). The system is divided into three main subsystems (i) energy storage and power generation, (ii) powertrain, and (iii) propulsor. In a classic fuel-based aircraft propulsion system, as shown in Fig. 1(b), a gas turbine engine powered by jet fuel drives a fan. Typically, the fan is mounted to the turbine duct, which results in the well-known turbofan. A turbofan engine, as depicted in Fig. 2(a), is mainly conformed by a fan, compressor, combustion chamber, and nozzle [21]. As a whole, the efficiency of a turbofan engine, i.e., shaft output power to input fuel energy flow ratio, can reach up to 45%

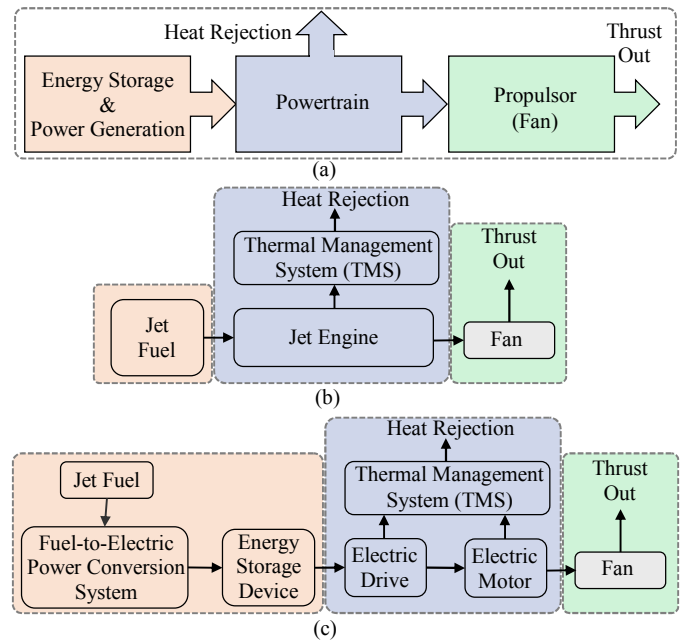

Fig. 1. General block diagram of an aircraft propulsion system; (a) general structure, (b) classic fuel-based propulsion, (c) and more-electric propulsion.

(55% for the turbine and 80% for the fan) [1]. This low efficiency is a consequence of the lossy thermodynamic and mechanical energy conversion processes, and it can be improved by transitioning to a more-electric powertrain architecture.

Fig. 1(c) depicts a more electric aircraft propulsion system formed by a combination of energy sources (i.e., jet fuel and electric energy storage devices), power converters, electric machines (i.e., generators and motors), and a propulsion fan. More specifically, the more electric propulsion system can be categorized into three main architectures (i) all-electric, (ii) hybrid-electric, and (iii) turboelectric [1], [22]:

A. All-Electric Powertrains

Fig. 2(b) shows the main block diagram of an all-electric aircraft powertrain architecture. In this architecture, the only energy source used onboard is a set of battery energy storage devices. Consequently, the all-electric architecture can achieve zero emissions. However, the implementation of this topology is limited by state-of-the-art energy storage devices.

B. Hybrid-Electric Powertrains

In a hybrid-electric powertrain, the onboard energy is supplied by jet fuel and electric energy storage devices. Accordingly, in a hybrid system, the propulsion of the aircraft can be performed by both the electric motor and jet engine. More specifically, a hybrid-electric powertrain architecture can be subdivided into three categories (i) parallel, (ii) series, and (iii) series/parallel. Fig. 2(c) depicts the general block diagram of a parallel hybrid architecture. Herein, a jet engine and a battery-powered electric motor are mounted to a single shaft that drives the propulsor fan. In this configuration, both the jet engine and electric motor can provide the fan separately or together to achieve higher efficiencies. In contrast, in a series

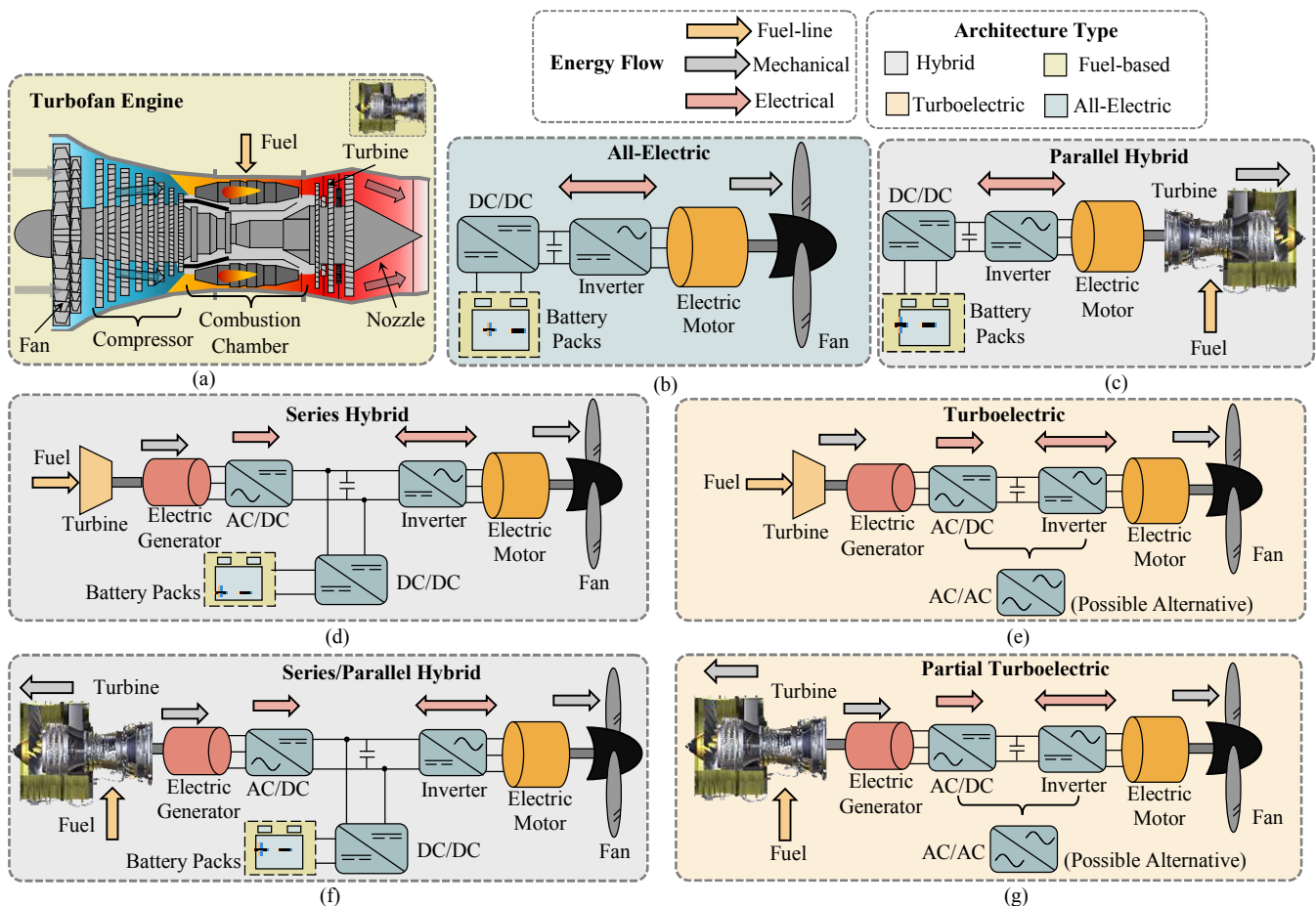

Fig. 2. Aircraft powertrain architecture; (a) classic fuel-based propulsion, (b) all-electric, (c) parallel hybrid, (d) series hybrid, (e) turboelectric, (f) series/parallel hybrid, and (g) partial turboelectric [1], [8], [22].

hybrid architecture, as shown in Fig. 2(d), the propulsor fan is driven only by the electric motor, which is electrically powered by a set of battery packs charged by an electric generator driven by a jet engine. Finally, Fig. 2(f) displays the structure of a series/parallel hybrid configuration. A turbine or an electric motor can drive the propulsor fans; these motors can be powered by a battery and turbine-driven electric generator. Notice that in the series and series/parallel configurations, the battery packs are connected in parallel with the dc-bus, and a dc-dc converter is often implemented to regulate the charging and discharging of the battery packs [12].

C. Turboelectric Powertrains and Distributed Propulsion

A turboelectric powertrain architecture, as depicted in Figs. 2(e) and 2(g) can be divided into two sub-categories (i) full turboelectric and (ii) partial turboelectric. The main highlight of these architectures is the lack of electric energy storage devices, which can potentially enable the use of state-of-the-art ac-ac power converters to interface the two machines and eliminate the fault-prone dc-bus electrolytic capacitors [23]. Analogous to the series hybrid powertrain architecture, the full turboelectric topology implements an electric motor as the propulsion device. Herein, the motor is powered by the electric energy provided by the onboard electric generators, which are driven by jet engines. On the other hand, the partial

turboelectric architecture utilizes jet engines and electric motors to provide propulsive power.

A turboelectric architecture by itself is less efficient (~10% less) than a conventional gas turbine engine due to the lack of additional energy storage devices [24]. Nevertheless, when implemented with distributed propulsion (DEP) and boundary-layer ingestion (BLI), it can reach higher efficiency levels than any fuel-based propulsion system [25]. In detail, distributed electric propulsion involves implementing high-power density and efficient electric motors to drive distributed electric fans that can be strategically placed on the aircraft to achieve a high effective bypass ratio, which results in higher propulsion efficiencies. Furthermore, electric generators and gas turbines can be positioned in different locations throughout the aircraft; thus, allowing an improved aerodynamic and weight profile. This feature is possible due to the simplicity of efficiently transporting electric energy onboard. Moreover, with BLI, the propulsion efficiency can be further increased by reducing the energy usage to ingest the thin, low-momentum air region at the aircraft structure. In summary, due to the lack of energy storage devices and the implementation of BLI and DEP, turboelectric architectures are considered the most attractive transitional topologies to begin the more electric powertrain aircraft era.

D. More Electric Powertrain Comparison

TABLE I
COMPARISON BETWEEN DIFFERENT MORE-ELECTRIC POWERTRAIN ARCHITECTURES [26]

Architecture Type	Advantages	Disadvantages
Series	<ul style="list-style-type: none"> – Turbine always operates at its peak efficiency rotational speed – Simplified gearbox / no transmission – Lower complexity turbine speed control – Distributed electric propulsion enabled 	<ul style="list-style-type: none"> – Lower efficiency at higher rotating speeds – Electric propulsion motor(s) and generator sized to maximum power rating; increasing cost, weight, and volume – Requires onboard electric generator
Parallel	<ul style="list-style-type: none"> – Higher overall efficiency at cruise speed – Fractionally-rated electric propulsion motor – No electric generator 	<ul style="list-style-type: none"> – Complex mechanical transmission – Turbine does not always operate at peak efficiency – Does not allow distributed electrical propulsion systems
Series/Parallel	<ul style="list-style-type: none"> – Maximum power-flow management flexibility – Smaller and more efficient turbine – Fractionally-rated electric propulsion motor 	<ul style="list-style-type: none"> – High-complexity gearbox required – Requires onboard electric generator – High complexity and overall weight profile

The seven aircraft powertrain architectures depicted in Fig. 2 can be further categorized in (i) fuel-based, (ii) hybrid, (iii) turboelectric, and (iv) all-electric. The main pros and cons of each category are directly related to their sources of energy. More specifically, the all-electric architecture has the advantage of zero-emission while fully depending on the development of high-power density batteries for its implementation. Similarly, hybrid topologies combine the benefits of lower emissions with smaller batteries; thus, providing a good compromise between the fuel-based and all-electric architectures. Nonetheless, hybrid topologies still depend on batteries, which positions them at a clear disadvantage point when compared to turboelectric architectures. These battery-less topologies are the most attractive short-term transitional solution, even considering their inherent lower efficiency when implemented without DEP. Lastly, a more detailed look at the advantages and disadvantages of series, parallel, and series/parallel architectures applicable to hybrid and turboelectric topologies is presented in Table I [26].

E. Challenges of More Electric Powertrains in Aircraft

Energy storage systems play a key role in hybrid and all-electric powertrain architectures, as demonstrated in Fig. 2. The energy (Wh/kg) and power (W/kg) density of an energy storage system are the most important parameters for an aircraft, as they determine the range and number of passengers. More specifically, the power density becomes relevant for the takeoff and climb portions of the flight, as these are the portions with higher power consumption [1], [19]. Fig. 3 depicts the energy and power density of state-of-the-art capacitors, supercapacitors, batteries, and fuel cells. Capacitors and supercapacitors are lighter than batteries and fuel cells, thus achieving higher power densities, whereas batteries and fuel cells achieve higher energy densities [19], [27].

Batteries are the preferred energy storage solution for modern electrified aircraft. The lithium-ion (Li-ion) battery is the current commercial state-of-the-art battery for automotive applications with an energy density of around 250 Wh/kg at the cell level, which translates into 110-160 Wh/kg for the whole battery pack, see Table II [28]–[33]. Further technological advancements incorporating silicon or silicon-carbon anodes are likely to achieve 400 Wh/kg at the cell level in the near

future, i.e., 2022-2025, by assuming an optimistic 8% average increase in energy density per year, which surpasses the historical 5% [19]. On the other hand, fuel cells, such as the proton exchange membrane fuel cell, which operates at lower temperatures (<100 °C), can achieve 600-800 Wh/kg with a drawback of lower power density when compared to batteries.

At the moment, state-of-the-art batteries and fuel cell technologies can achieve 400-500 Wh/kg on average. Considering kerosene-based jet fuel (e.g., Jet A-1) has an equivalent energy density of 11,889 Wh/kg (42.8 MJ/kg) [34], [35], the state-of-the-art energy storage systems show a significant disadvantage. Fig. 4 demonstrates the tradeoff existing between range and number of passengers for hybrid and all-electric aircraft, assuming an energy storage system energy density of 400-500 Wh/kg. Here, it is clear how increasing the number of passengers impacts the range and vice-versa. Moreover, hybrid powertrain architectures can fly longer distances or hold more passengers than an all-electric architecture with the same energy density battery. At best, a hybrid aircraft can carry 10 passengers for almost 1,000 miles or between 50-70 passengers for 300 miles. These operational specifications limit the commercial viability of hybrid and all-electric aircraft. With this in mind, it is projected by The National Academies of Sciences, Engineering, and Medicine's Committee on Propulsion and Energy Systems to Reduce Commercial Aviation Carbon Emissions that for hybrid and all-electric aircraft to be viable, their energy storage systems must reach 800 Wh/kg for a hybrid and 1,800 Wh/kg for all-electric, which can take up to 20 years based on the current trends [1].

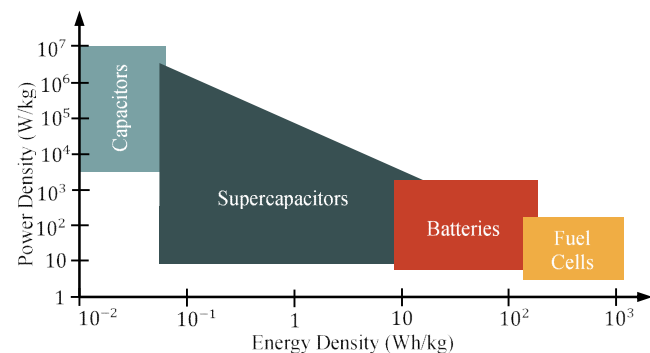

Fig. 3. Comparison of the power and energy density of several electrochemical energy storage options [19], [27].

TABLE II
COMPARISON BETWEEN LI-ION BATTERIES AND OTHER TYPES OF BATTERIES [26]

Battery Type	Lead-Acid [28]	Ni-Cd [29]	Ni-MH [30]	Zn-Br [31]	Fe-Cr [32]	Li-ion [33]
Energy Density (Wh/kg)	30-50	45-80	60-120	35-54	20-35	110-160
Power Density (W/kg)	180	150	250-1000	-	70-100	1800
Energy Efficiency	70%	60-90%	75%	80%	66%	80%

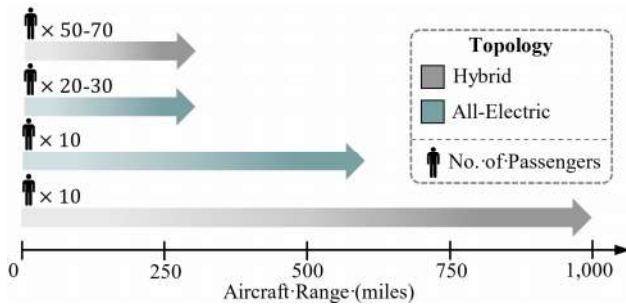

Fig. 4. Hybrid and all-electric aircraft range with passenger count enabled by battery cells with an energy density of 400-500 Wh/kg [19].

Although the main limitation toward implementing more electric powertrains resides in the power/energy density of the electric energy storage systems, other challenges such as reliability, life cycle, and cost across each component of the powertrain play a pivotal role when assessing the feasibility of the overall system. More specifically, the main powertrain components, i.e., electric machines, power converters, and battery packs, must comply with strict aerospace safety and reliability standards, e.g., DO-254 [36]. Furthermore, widely accepted lifetime models of modern electric machines and power converters may require revisions to be valid in aerospace conditions. In light of this, reliability and life cycle requirements are significant challenges to be addressed. In contrast, cost remains a secondary objective guided by the scalability business models of the aerospace industry [37].

III. ELECTRIC MACHINES FOR MORE ELECTRIC POWERTRAINS

All-electric and hybrid powertrain architectures have demonstrated their effectiveness in the auto, rail, and marine industries [11]. In these applications, the electric motors are only a few hundred kW with power densities ranging from 1 to 3 kW/kg. In contrast, it is estimated that for an aircraft powertrain, the rated power for the electric propulsion motors could achieve up to tens of MWs for wide-body airplanes. As a result, electric motors for aircraft applications must exhibit power densities above 10 kW/kg for all-electric and hybrid powertrains to be feasible [1], [8], [38]. The power density as a function of the rated power for some commercially state-of-the-art electric motors is depicted in Fig. 5. Herein, Axial-Flux Permanent Magnet Machines (AFPM), Wound-Field Synchronous Machines (WFSG), Switched Reluctance Machines (SRM), Synchronous Reluctance Machines (SynRM), Radial Flux Permanent Magnet Machines

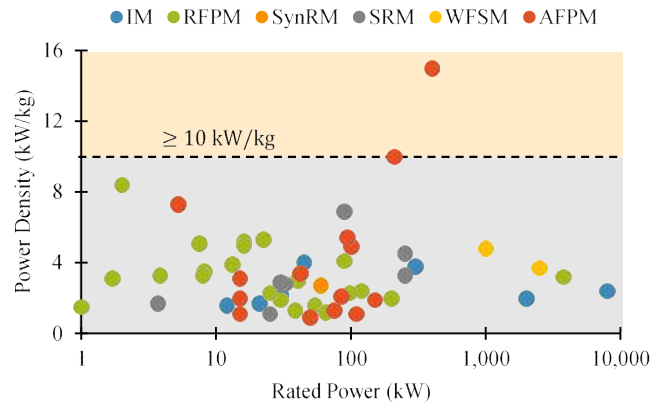

Fig. 5. Power density as function of power for state-of-the-art commercially available electric machines [8].

(RFPM), and Induction Machines (IM) are graphically compared demonstrating the overall power density spectrum available in the market. In addition, Fig. 5 depicts how for high power rating, the power densities are far from the 10 kW/kg aircraft requirement. It may take several decades to reach a power density of 9 kW/kg for electric machines rated between 1 to 3-MW, as projected in [8]. Considering this projection, transforming and innovative designs must be explored to make a more electric powertrain feasible in the near future.

In this section, electric generators and motor technologies for aircraft applications are described. First, the advantages and challenges of variable-speed electric generation systems are discussed. Second, the state-of-the-art electric propulsion motors are analyzed, focusing on the advantages of the AFPM, which at the moment postulates itself as the machine type with the highest power density. Subsequently, some machine thermal management techniques are briefly described. Lastly, a generalized comparison of the main machines discussed in this section is presented with a descriptive table.

A. Electric Generators

The MEA electric power generation system revolutionized the aircraft industry by incorporating a variable-speed electric generator, which is directly coupled to the jet engine, thus increasing the reliability while reducing the size and weight of the system [17]. Following this trend, variable-speed generators are expected to continue to be the preferred alternative for hybrid and turboelectric powertrains. Furthermore, using this technology, higher power-densities can be achieved by increasing the speed, efficiency, and output voltage (limited to breakdown voltage at high pressure/altitude environment) [1].

The most commonly and extensively used machine for electric power generation in an aircraft is and remains the wound field synchronous generator (WFSG) [17]. Among its main advantages, the WFSG offers (i) full-field controllability, (ii) excellent fault mitigation capability, (iii) simple control, and (iv) various operation modes (e.g., starter generator, three-stage starter-generator, among others) [6]. However, recent state-of-the-art machine-related research is now focusing on two types of electromechanical converters permanent magnet synchronous generator (PMSG) [39]–[43], and hybrid excitation synchronous generator (HESG) [44]–[46]. Despite their advantages, WFSG and HESG offer lower efficiencies

and power densities levels when compared to PMSG. Consequently, it is expected that the new generation of electric aircraft generators shifts toward PMSG technology, following the pattern explored by the automotive industry [47], [48]. Lastly, it is important to notice that this technological trend toward implementing PMSGs will be constrained to the challenges of operating these types of machines in a high-temperature environment, such as the ones present in an aircraft when the generator is installed in the vicinity of the jet engine. At high temperatures, a PMSG will suffer performance degradation mainly due to the heavy dependence of the permanent magnets' material properties as a function of the operating temperature [49]. More specifically, both the remanence and intrinsic coercivity of the magnet material change with temperature, thus affecting the electric torque generation of the machine. In addition, the winding resistivity and the properties of the core are temperature depended, which will further affect the performance of the PMSG [50].

B. Propulsion Electric Motors

A comprehensive review of high power density electric machines focusing on state-of-the-art commercial machines that are commercially available is presented in [51]. Herein, IM, WFSM, RFPM (interior and surface), and AFPM are analyzed and categorized by power level and application, i.e., land-vehicle propulsion or aerospace applications. Among the land-vehicle propulsion electric machines with rated powers ranging from 50 to 115-kW, the highest power density motor reported is an interior magnet RFPM from the Karlsruhe Institute of Technology at 5-kW/kg, followed by a surface magnet RFPM from McLaren at 3.8-kW/kg. On the other hand, for aerospace applications with rated powers above 100-kW, Siemens and Honeywell achieved the highest power densities at 7-8 kW/kg with a WFSM and surface magnet RFPM. For higher-rated power machines, the NASA Glenn Research Center has sponsored the development of three propulsion motors in the MW-range, with two of the motors reaching 13-kW/kg — one IM developed by the Ohio State University and a RFPM developed by the University of Illinois [52].

As demonstrated in [51], Permanent magnet (PM) motors have been gradually replacing dc and induction machines in traction applications in the past decade. Compared to other electromechanical converters, a PM machine offers increased efficiency and power density at the expense of higher costs due to the PM materials utilized in their construction [11]. In recent times, AFPM motors, as shown in Fig. 6(b), have gained popularity in the transportation electrification sector due to their high power density and specific power compared to classic radial PM machines, see Fig. 6(a) [53]. More specifically, the authors in [53] demonstrate that for a specific air-gap flux density and magnet material, the rotor moment of inertia of an AFPM machine tends to be smaller compared to its radial counterpart; hence achieving faster dynamics, which can allow the design of higher bandwidth controllers capable of driving the propulsor fan effectively without stalling throughout its operating range [54].

In addition, terms of their cost, AFPM motors are less costly

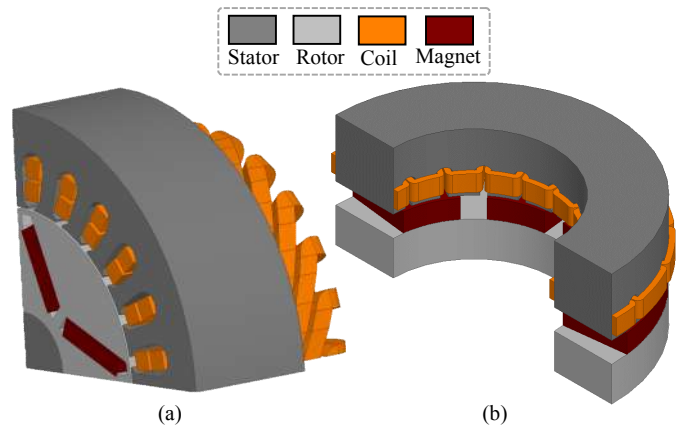

Fig. 6. 3D view of permanent magnet synchronous machines; (a) radial and (b) axial flux.

than RFPM machines [55]. That being said, based on the works presented in [53], [55], [56], AFPM motors are generally viewed as well suited for direct-drive medium-speed/high-torque applications, thus postulating themselves as the ideal machine to carry the technological transition toward the more-electric powertrain in aerospace applications.

Axial flux permanent magnet machines have been investigated for the past 30 years, reaching technological maturity in a wide variety of applications, e.g., electrification transportation and renewable energies. In [55], the authors summarize the recent advances in AFPM machines. Herein, the maximum power density reported is 2-kW/kg for a 15-kW, 4500 r/min generator directly coupled to an internal combustion engine in a series HEV drivetrain [57]. Similarly, the authors in [8] outline the commercially available and prototype state-of-the-art AFPM motors for aircraft propulsion. In this work, the reported power densities range from 0.9 to 4.9-kW/kg, with the ERAX prototype motor leading the power density category. Alternatively, in [58], a 5.4-kW/kg AFPM motor rated at 94-kW is presented. An even higher power density is presented in [59] with the EMRAX 348 rated at 210-kW with a power density of 10 kW/kg at a maximum speed of 4,000 r/min. Nevertheless, the highest commercial AFPM motor prototype is the Magnax AXF290, with a peak power of 400-kW and a power density of 15-kW/kg [60]. That being said, even at these remarkable power density levels, state-of-the-art AFPM motors are only available in the hundreds of kW range, as depicted in Fig. 5. Consequently, AFPM machines have been limited to in-wheel EV traction [55]. With this in mind, future research on AFPM machines must tackle the rated power limitation while still achieving high power density levels at the MW range.

On the other hand, the recent research trend in electric machines is actively investigating superconducting machines for aerospace applications due to their high efficiency and power density [61]. Recent studies conducted by NASA estimate that a cryogenic motor design can achieve 125 times the power density of a conventional electric motor and 3.3 times the power density of large turbine engines [25]. In light of this, researchers at the NASA Glenn Research Center have oriented their efforts toward developing MW high-efficiency

electric propulsion motors with a superconducting rotor. One example is the NASA High-Efficiency Megawatt Motor (NASA-HEMM), rated at 1.4-MW with a 16 kW/kg power density at nearly 99% efficiency [62]. Following this trend, fully superconducting motors in the MW power range have been recently studied in [63]–[65]. In [63], a 2-MW fully superconducting synchronous motor with superconducting magnetic shields has been proposed for turboelectric aircraft propulsion. Herein, two designs are presented showing 40kW/kg at an operating temperature of 20K and 20kW/kg at 64K with both designs above 99% efficiency. A more general study comparing non-superconducting and superconducting machines for aircraft applications is performed in [64] by Raytheon Technologies. The study compared RFPM to fully superconducting machines from 1 to 10-MW at different speeds considering a maximum frequency of 2-kHz. For both machines higher speeds yield an increase in the power density of the motor reaching nearly 24-kW/kg for the RFPM and between 45 and 60-kW/kg (depending on the number of poles) for superconducting motors. Lastly, in [65], three 5000-HP (3.73-MW) different machines are compared for propulsion application. The study analyzed an IM, RFPM, and a high-temperature superconducting motor (HTSM). The results showed the superior power density of the HTSM, which doubled the power density of the IM and exceeded 26%, the same metric of the RFPM.

That being said, for large-capacity commercial aircraft with propulsion power requirements from 2 to 10-MW, in which the minimum NASA projected power density requirement is 16 kW/kg [62], fully superconducting motors are set to lead the effort as the primary candidate given they overcame a variety of technical challenges such as loss of superconductivity, cryogenic temperature requirements, rotating cryogenic cooling systems, fragility compared to copper and aluminum, cost, and manufacturing in a commercial timeframe [62], [65].

C. Electric Machines Thermal Management

The maximum temperature in the propulsion machines is constrained by the insulation and magnetic material thermal characteristics [66]. In other words, the performance and power density of electric machines is highly limited by the temperature rise limit of the materials [67]. As a result, thermal management systems are critical for aircraft powertrain electrification.

In [67], the authors present a comprehensive review of thermal system designs for improving power density in aircraft electric machines. Herein, the analyzed thermal designs are organized in four main categories based on their position (i) housing (air/liquid), (ii) stator (oil-flooded [68], [69]), (iii) winding (oil spray [70], coolant channel [71], [72], potting material [73], [74], slot insertion [75], and heat pipes [76]), and (iv) rotor (ventilation [77] and hollow shaft [78]). For cooling electric machines in more electric aircraft powertrains, natural housing cooling with surface fins or forced convectional cooling with fans, as shown in Fig. 7(a), may not meet the gravitational and volumetric power density requirements due to the concerns on the weight and physical footprint. Instead,

housing liquid cooling, such as using Kerosene and other jet fuels, is a common and effective heat transfer approach for the thermal management of machines in airplanes, as shown in Fig. 7(b) [79]. With liquid cooling, the total loss of the motor is dissipated based on the flow rate of the coolant and the temperature rise between the inlet and outlet, which can be expressed as [80]:

$$Q = \left(\rho \frac{\dot{V}}{60000} \right) C_p (T_{out} - T_{in}) \quad (1)$$

where Q is the heat flow rate (J/s = Watt), ρ is the coolant density, \dot{V} is the volumetric flow rate of the fluid (liters/min), C_p is the heat capacity, and T_{out} and T_{in} refer to the temperature of the outlet and inlet coolant in (°C), respectively. As can be seen in (1), the selection of the coolant plays an important role in heat dissipation. Alternatively, using heat pipes is another effective approach to cool stator windings and rotors of electric machines in aircraft, as illustrated in Fig. 7(c). In this approach, the heat pipe evaporator is inserted into the motor housing to absorb heat, while the condenser is placed in a cooling chamber for heat rejection [81]. A hybrid utilization of liquid cooling and heat pipes is also an effective approach that can be considered, as presented in Fig. 7(d), but the manufacturing cost and the hardware complexity could be high. In summary, among the categories and methods studied in [67], the authors highlighted winding slot insertion [75], heat pipes [76], and rotor ventilation [77] as the thermal systems with the lowest, i.e., <5%, overall mass increase. Nonetheless, the optimal thermal management solution should be determined by careful consideration of the machine losses, mission profile, reliability, weight, physical volume, and cost.

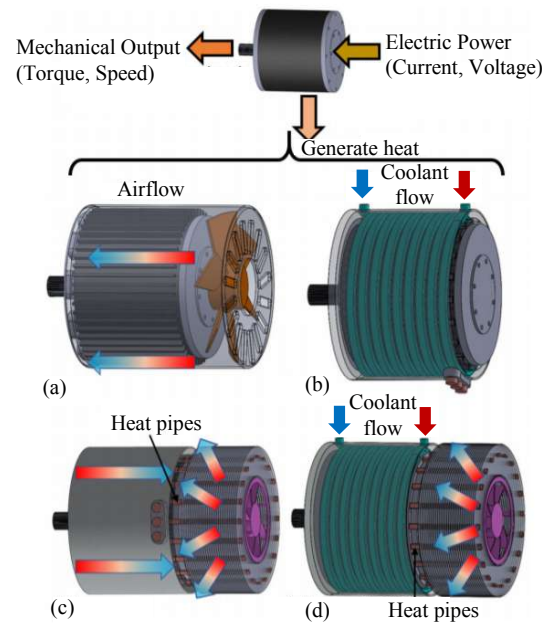

Fig. 7. Electric motor cooling strategies (a) surface air cooling with a fan coupled to the shaft, (b) liquid cooling with coolant jacket, (c) heat pipe cooling with attached fins and a centrifugal fan, and (d) hybrid cooling with heat pipes and liquid [79].

D. Electric Machine Comparison for Aircraft Powertrains

TABLE III
COMPARISON OF ELECTRIC MACHINES FOR MORE-ELECTRIC POWERTRAINS [82]

	IM	WFMSM	RFPM & AFPM	HTSM		
Advantages	<ul style="list-style-type: none"> – High robustness – Build simplicity – High speed capability – High reliability – Lowest cost 	<ul style="list-style-type: none"> – High controllability – Controllable power factor – Somehow reliable 	<ul style="list-style-type: none"> – High power density – High efficiency 	<ul style="list-style-type: none"> – Highest power density – High efficiency 		
Disadvantages	<ul style="list-style-type: none"> – Lowest power density – Lowest efficiency – Reduced power factor – Thermal management 	<ul style="list-style-type: none"> – Lower power density – Lower efficiency – Complex structure – Limited speed – Thermal management – Cost of added components 	<ul style="list-style-type: none"> – Reduced robustness – Reduced reliability (PM) – Critical thermal management to prevent demagnetization – PM cost 	<ul style="list-style-type: none"> – Highest complexity structure – High and complex thermal management requirement – Limited speed – Reduced reliability – High cost 		
Potential Application Areas [82]	<ul style="list-style-type: none"> – Propulsion – Generation 	<ul style="list-style-type: none"> – Propulsion – Actuators – Flywheels 	<ul style="list-style-type: none"> – Generation – Fuel pumps 	<ul style="list-style-type: none"> – Propulsion – Taxiing – Fuel pumps 	<ul style="list-style-type: none"> – Generation – Actuators – Flywheels 	<ul style="list-style-type: none"> – Starting/Generation – Taxiing – Fuel pumps – Flywheels

Table III shows a detailed comparison of the electric machines discussed in this section. Moreover, the advantages, disadvantages, and possible application areas are outlined. Herein, it is clear that PM machines and HTSM postulates themselves are the most attractive candidates for aircraft applications, given their high power-density and efficiency. Nonetheless, HTSM must overcome their thermal management requirements to be considered in future more electric powertrains. Finally, a more detailed and thorough review of machines in aircraft is presented in [82].

IV. AIRCRAFT POWERTRAIN POWER CONVERTERS AND HIGH-VOLTAGE ELECTRIFICATION

As the aerospace industry advances toward more electric powertrain architectures, the focus is now shifted to the onboard power converters, which must guarantee a sound performance (e.g., high efficiency, high power density, and robustness) while offering high reliability under any operating scenario.

Following the MEA trend of utilizing variable-speed generators, which produce a constant-amplitude/variable-frequency ac-bus, the next generation of more electric aircraft powertrain power converters must now operate with a variable-frequency input voltage [2], [3], [15]. This variable-frequency technology has been applied for decades in the automobile, railway, and industrial; and can now serve as the base for aircraft power converters.

A. Powertrain Power Converters

In terms of efficiency and power density of power converters, the emerging wide-bandgap semiconductors, i.e., Silicon Carbide (SiC) and Gallium Nitride (GaN), postulate themselves as some of the key enablers to make electric aircraft powertrains more efficient and compact. These semiconductors offer lower conduction and switching losses at higher temperatures with smaller footprints than their Silicon counterpart [20], [83], [84]. Currently, SiC switches have been pursued to develop power conversion products by aviation manufacturers [85], [86]. Although the current GaN switches

available in the market offer limited voltage and current ratings, it is expected that a full GaN converter could potentially outperform both Si- and SiC-based converters in the power range of tens or hundreds of kW scale [87]. For MW-scale power converters, high-voltage SiC modules, such as the 1.7kV and 3.3kV SiC modules, can boost the efficiency and power density. It should be noted that the differential-mode and common-mode dv/dt and di/dt with SiC and GaN devices during their switching are much higher than these with Silicon counterparts [88], so extra attention should be paid to the electromagnetic interference (EMI) filter design to meet the aviation EMI standards, e.g., Radio Technical Commission for Aeronautics (RTCA) DO-160 [89].

1) *AC-DC Power Converters*: Three-phase active rectifiers or ac-dc converters are utilized in hybrid and turboelectric powertrain architectures to convert the ac output voltage of the onboard electric generators to dc. The output of this converter is the main dc-bus of the powertrain from where the electric propulsion drives are connected. In hybrid architectures, an electric energy storage device can be connected in parallel to the dc-bus. The main functionalities of an aircraft active rectifier are to regulate the dc-bus voltage and control the power factor on the generator-side while maintaining a low total harmonic distortion (THD) in the generator currents [90].

Throughout the years, active rectifier topologies and control schemes have been extensively investigated [90]–[92]. However, in powertrain architectures where the onboard generator is directly connected to the jet engine, e.g., hybrid and turboelectric, the input of the ac-dc converter is a variable-frequency/amplitude ac-voltage, which complicates the design.

In an MEA, a passive multi-pulse autotransformer rectifier unit (ATRU), as shown in Fig. 8(a), performs the ac-dc conversion. Nonetheless, this passive converter generates low-order harmonics and offers no power factor regulation [93]. Consequently, the new generation of ac-dc converters must operate at variable-frequency. Several papers have studied the control of active rectifiers in MEA applications with the focus of integrating its controller with the electric generator dynamic [39]–[43]. In [81], [94], different topologies are proposed and

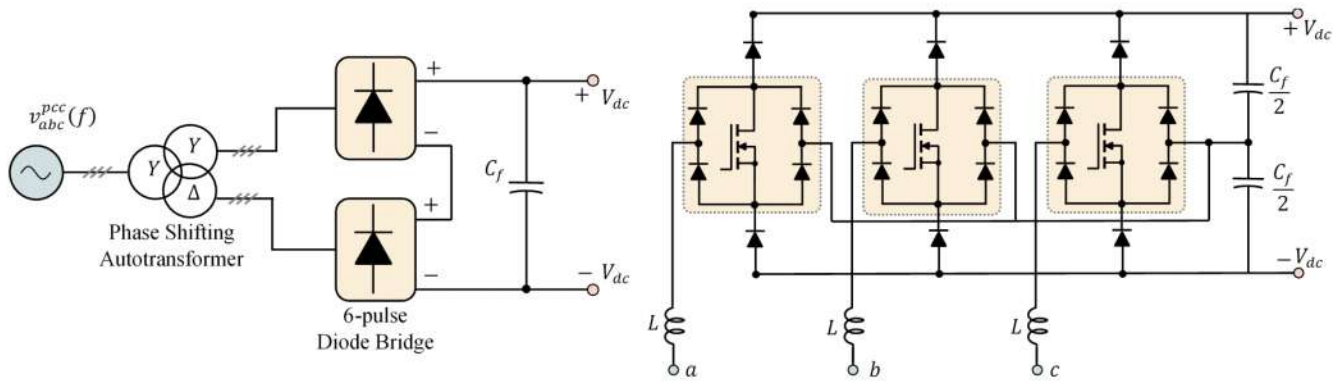

Fig. 8. AC-DC power converters for MEA; (a) multi-pulse autotransformer rectifier unit (ATRU) and (b) Vienna rectifier [22], [93], [94].

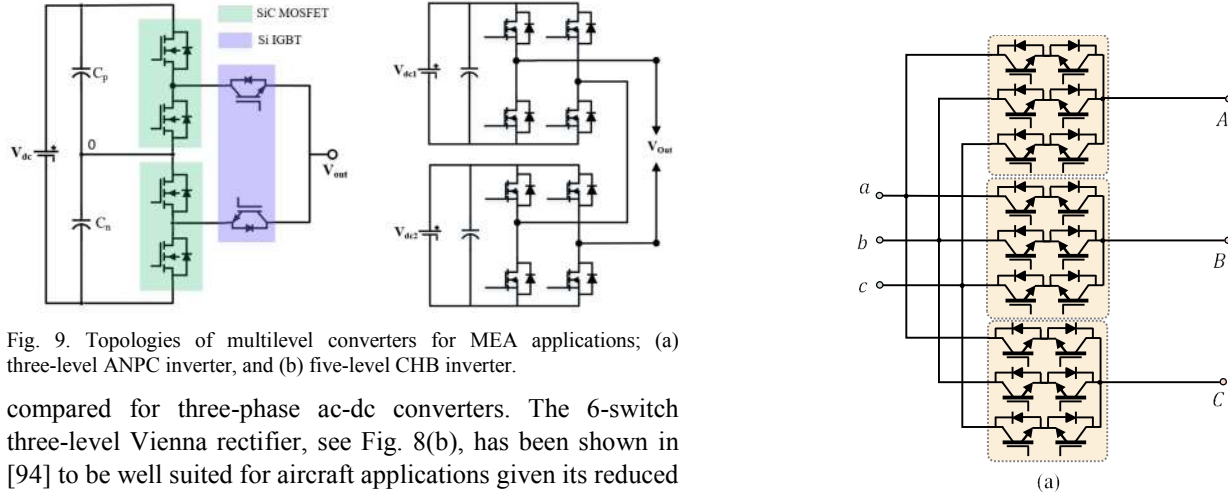

Fig. 9. Topologies of multilevel converters for MEA applications; (a) three-level ANPC inverter, and (b) five-level CHB inverter.

compared for three-phase ac-dc converters. The 6-switch three-level Vienna rectifier, see Fig. 8(b), has been shown in [94] to be well suited for aircraft applications given its reduced semiconductor voltage stress, which can enable higher voltage levels, thus potentially enabling an increase in the power density of the converter. Lastly, a variable-frequency ac-dc converter is proposed in [95] and [96], where an indirect and direct adaptive control schemes are proposed to enhance the controller's performance under rapid input frequency variation and system parameter variations due to extreme pressure and temperature changes.

2) *DC-AC Power Converters*: A three-phase inverter or dc-ac converter is in charge of controlling the propulsion motor in a more-electric powertrain. In addition, this inverter must be bidirectional to allow regenerative braking. The main inverter topology used in the aviation industry is the conventional three-phase six switch voltage source inverter due to the technical maturity and simple control. However, with the dc voltage level moves to a higher voltage, multilevel voltage source inverters have been preferred for MEA applications due to their advantages of withstanding higher voltage, higher efficiency, lower harmonic distortions, lower dv/dt , and common-mode voltage stress. In [97], a three-level active neutral point clamped (ANPC) inverter based on a hybrid utilization of the SiC MOSFET and IGBT modules was developed for a 2.4kV MW-scale hybrid-electric aircraft propulsion drive system, where a nominal efficiency of 99% and specific power of 12 kVA/kg was demonstrated. The circuit topology of this three-level ANPC inverter is shown in Fig. 9(a), where the SiC MOSFETs are used for high-frequency switching (i.e., carrier frequency), while the Si IGBTs are

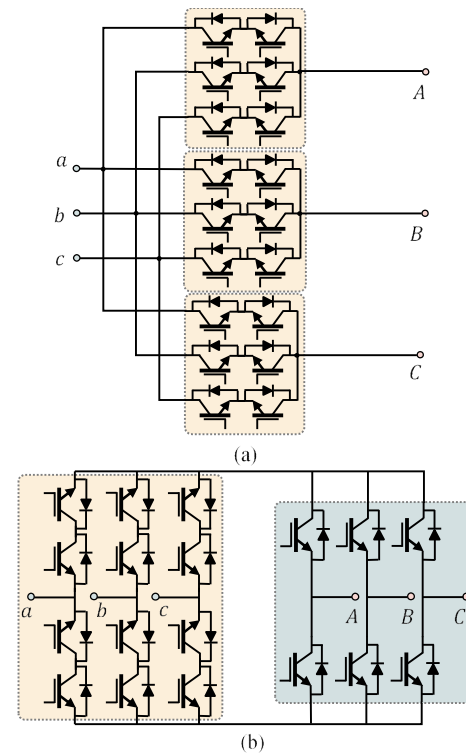

Fig. 10. Matrix ac-ac converters topologies; (a) direct (b) indirect [100].

operated at the fundamental output frequency in addition to being utilized to constrain the fault current during a line-to-line or line-to-ground short-circuit faults. Moreover, cascaded H-bridge (CHB) multilevel converters have also been proposed for MEA applications due to the modular structure and high-quality output waveforms [98]. The topology of a five-level CHB inverter is shown in Fig. 9(b). As can be seen, the CHB inverter requires isolated dc sources, which is suitable for battery-powered all-electric MEA, where separate battery packs can be used as isolated dc sources. Finally, in addition to efficiency and power-density, a propulsion inverter must be fault-tolerant. Fault-tolerant motor drives have been extensively discussed in the literature [99], and their applications to aircraft electric powertrains could open a unique research avenue.

3) *AC-AC Power Converters*: direct and indirect matrix ac-ac power converters, see Fig. 10, have been proposed for MEA

applications due to their advantages of lower weight and smaller physical volume, as well as higher reliability due to the elimination of dc-link capacitors, which are vulnerable components typically existing in conventional voltage source converters [100]. In [101], a direct matrix converter is developed for an Airbus A320 electro-hydrostatic actuator (EHA) system. Herein, the three-phase matrix converter feeds a high-speed permanent magnet motor. More specifically, in the proposed direct matrix converter, nine arrays of bi-directional semiconductor switches are implemented. Each semiconductor switch is configured by two IGBTs connected in anti-series. In addition, an input (inductive-capacitive) LC filter is typically required to attenuate harmonics related to the converter switching frequency. However, no bulky intermediate dc-link capacitors or dc inductors are needed, thus enabling high-power density and reliability.

In [102], an indirect matrix converter (IMC) is proposed for an aircraft starter/generator system. The circuit topology of the IMC includes two power stages, the front-end current-source-rectifier, and the back-end voltage-source-inverter. The rectifier stage is composed of six bi-directional switches, each switch containing two IGBTs connected in a common source. On the other hand, the inverter stage consists of six unidirectional switches, similar to a conventional voltage-source inverter. Lastly, although the IMC topology looks like a conventional ac-dc-ac back-to-back power converter structure, no dc-link energy storage components are needed for an IMC. One additional benefit offered by the IMC topology is the dc-link access to interconnect a battery energy storage system in a more electric powertrain, which is not possible for a direct matrix converter [103]. That being said, despite their superior power density, conventional direct and indirect matrix converters are incapable of boosting the output voltage and offer limited input current regulation; thus making the back-to-back power converters the preferred topology for immediate implementation in the future more electric powertrains [104].

4) *DC-DC Power Converters*: In a more-electric powertrain, the buck-boost dc-dc converters can be used to manage the power between the battery, dc loads, and other possible dc sources such as supercapacitors or even solar panels on the aircraft. In many demonstrated aviation projects, dual active bridge (DAB) dc-dc converters have been utilized due to their advantages of high efficiency, high power density, galvanic isolation, and bidirectional power flow [105]. In conventional aircraft electrical systems, 28V and ± 270 V are the standard dc power, but the trend is moving towards higher dc-bus voltage, such as 540V or 1kV [2]. However, for many aviation dc components, the transition from low voltage to high voltage may take several years or even decades to complete, resulting in a hybrid dc distribution system consisting of both low voltage and high voltage components. In such a scenario, a multi-port dc-dc converter such as triple active bridge (TAB) or quadruple active bridge (QAB) converters can be utilized to interface the dc power at various ports [106]. The circuit topology for a full bridge TAB converter (QAB has one more port than TAB) is shown in Fig. 11, in which three H-bridge converters are

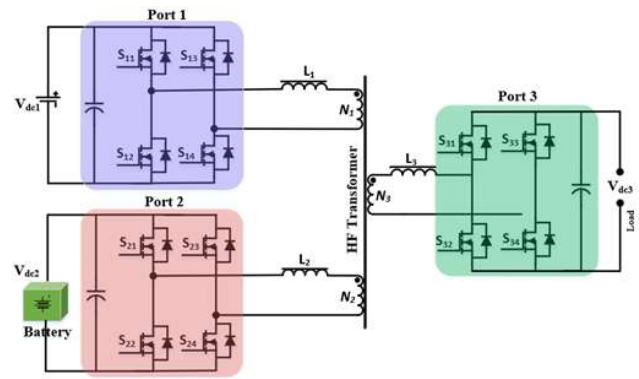

Fig. 11. Triple active bridge three-port dc-dc converter for aircraft dc distribution system.

interconnected by a phase-shifting transformer. The power flow between any of the two ports can be controlled by adjusting the phase shift angle, as expressed in the equation below (taking port 1 and port 3 as an example):

$$P_{13} = \frac{V_{dc1}V_{dc3}}{2\pi f_s L'} \phi_{13} \left(1 - \frac{|\phi_{13}|}{\pi} \right) \quad (2)$$

where, P_{13} refers to the power flow between port 1 and port 3; V_{dc1} and V_{dc3} are the dc-bus voltage at port 1 and port 3, respectively; f_s is the switching frequency, L' is the leakage inductance of the transformer, ϕ_{13} is the phase shift difference between port 1 and port 3.

Additionally, by using the emerging SiC or GaN devices for the TAB converters, the physical size of the phase-shifting transformer can be significantly reduced by using high switching frequency, leading to a higher power density of the whole converters.

B. Toward Higher Voltage Powertrains

In parallel to the development of power converters for the next generation of more electric powertrains. The electrification of the onboard electric power system must be considered as part of the power density, efficiency, and desirable reliability goals. As a result, medium-voltage-dc (MVDC) apparatus have been proposed as an enabling technology for wide-body twin-aisle airplanes to significantly enhance the power density and efficiency of MW-scale electrical systems [107]–[109].

1) *Advantages of Higher Voltage Powertrains*: Specifically, MVDC has the following advantages compared to the existing dc (e.g., ± 270 V) or low-voltage ac (e.g., 115V) for aircraft electrical systems:

- *Lower Cable Weight and Cost*: For dc transmission systems containing only the positive conductor and the ground, a single conductor can be used, while three-phase conductors are required in ac transmission systems. The adoption of MVDC transmission may significantly reduce cable weight and cost, especially for wide-body large-capacity airplanes [110].
- *Elimination of Skin Effect and Proximity Effect Losses*: In traditional aircraft, ac transmission systems, typically

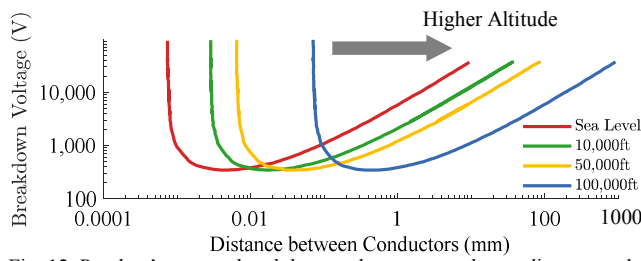

Fig. 12. Paschen's curves: breakdown voltage vs. conductor distance and altitude [112].

high-frequency (e.g., 400 Hz and 800 Hz) is used to reduce the size of magnetic components such as electric machines or transformers. Consequently, skin effect and proximity effect losses in the conductors can be very significant, but such losses can be eliminated in dc transmission in aircraft electrical systems.

- *Lower Corona Effect:* Corona effects tend to be less significant on MVDC conductors than for medium-voltage-ac (MVAC) counterparts. In an MVAC system, due to the higher voltage and faster switching of modern semiconductor devices, the increased dv/dt poses more challenges on the insulation design of the electric apparatus, such as stator windings of electric machines, laminated high-voltage bus bar designs of power converters, among others.

2) *Challenges of Higher Voltage Powertrains:* In the present, more electric aircraft systems, such as Boeing 787 and Airbus 380, $\pm 270V$ is the dominant dc-bus voltage rectified from engine-driven generators. If such dc-bus voltage can be boosted to 1000V, 2000V, or above, the systematic power density and efficiency will be dramatically increased. Particularly, the recently commercial availability of high-efficiency, high-voltage SiC MOSFETs (e.g., 1.7kV, 3.3kV, etc.) further promotes the development of MVDC systems for hybrid-electric or all-electric aircraft [97], [111]. Nevertheless, there are a few key challenges to be addressed during the development of MVDC systems for electric aircraft, which are summarized as follows:

- *Increased Insulation Stress at High-Altitude:* According to Paschen's Law (the Paschen's curves are shown in Fig. 12 [111], [112]), for a given clearance between conductors, the higher the altitude, the lower the breakdown voltage. This is mainly because air is less dense as an insulator with altitude increases. For instance, for a 10 mm distance between conductors, the breakdown voltage for such clearance will be 30kV-dc at sea level, which decreases to only 1.2kV at 50,000 feet. Such degraded insulation poses many challenges to the clearance and creepage design in aircraft MVDC systems at high altitudes, which may, in turn, reduce the volumetric power density of aircraft power apparatuses such as electric machines and power converters. Paschen curve is often used to determine the Partial Discharging Inception Voltage ($PDIV$), i.e., the minimum voltage to be reached to initiate the first discharge. The relationship between the $PDIV$ and the insulation grade, pressure, and the nominal diameter of the conductor can be expressed as follows [113]:

$$PDIV = b_1 G \cdot P + b_2 D^{b_3 GP} + b_4 \quad (3)$$

where b_1 , b_2 , b_3 , and b_4 are the regression coefficients, G is the grade chosen for insulation, and D is the nominal diameter of the conductor. The variable P is the pressure, which is also a function of the altitude and temperature, as shown below:

$$P(h) = P_b \left(\frac{T_b}{T_b + L_b(h - h_b)} \right)^{\frac{gM}{RL_b}} \quad (4)$$

where h is the altitude, P is the pressure, T is the temperature in Kelvin. The b subscript is used to mark the transition between different layers of the atmosphere and define reference pressure and temperature values. $L_b = -0.0065$ K/m is the standard temperature lapse rate; G , M , and R are the gravity acceleration, the molar mass of air, and the universal gas constant, respectively.

Particularly, the emerging trend of utilizing wide bandgap semiconductor devices for high-efficiency lightweight power converters incurs higher insulation stress to both the converters themselves, cables, and electric machines, due to the high-frequency switching in the MVDC propulsion systems. High power and high current density require thinner insulation to conduct the heat more effectively. Conventional insulation materials used in electric machines on aircraft consist of polymeric coatings, polymeric films, and papers, such as Kapton and Nomex, which provide excellent electric insulation but poor thermal conduction, in addition to the easily degraded characteristics under electric discharge [114]. Therefore, high-performance dielectric coating materials that possess satisfied thermal conductivity and temperature stability will be of high necessity.

- *Fault Protection in MVDC Systems:* Fault protection in dc systems is more challenging than that in ac systems due to the unavailability of natural zero crossing in dc current, which is required for contact separation in circuit breakers. However, intensive research has been conducted to develop various solutions for MVDC systems, including hybrid circuit breakers and solid-state circuit breakers, as detailed in [115]. Typically, the hybrid breakers have very low on-state conduction losses, but the fault interruption speed could be slow. On the contrary, the solid-state breaker is fast in fault isolation, but the on-state losses can be significant, especially for MVDC, where a number of semiconductor switches will be connected in series to withstand the high dc voltage.
- *Cosmic Ray Impact on High-Voltage Semiconductor Devices at High-Altitude:* It is reported that intensive cosmic rays at high altitude may damage semiconductor devices since the high-energy terrestrial neutrons might cause a temporary short between the device terminals resulting in gate rupture or burnout due to increased gate field or parasitic bipolar turn-on, respectively [116], [117]. As the altitude increases, the associated neutral flux also approximately increases exponentially. For the same reliability target, the higher the dc-bus voltage of power electronic systems, the lower

utilization of the blocking voltage rating of the semiconductor devices. A mathematic model has been developed in [116] to calculate the cosmic ray related failure rate of semiconductor devices by accounting for the three important factors, including blocking dc-bus voltage, junction temperature, and altitude levels, as shown below:

$$\lambda(V_{dc}, T_{vj}, h) = C_3 \exp\left(\frac{C_2}{C_1 - V_{dc}}\right) \exp\left(\frac{25 - T_{vj}}{47.6}\right) \exp\left(\frac{1 - \left(1 - \frac{h}{44300}\right)^{5.26}}{0.143}\right) \quad (5)$$

where, λ refers to the failure rate in FIT (i.e., number of failures within 10^9 device hours). C_1 , C_2 and C_3 are characteristic values of individual devices that can be acquired from device manufacturers. V_{dc} , T_{vj} , and h refer to the dc-bus voltage, junction temperature, and altitude level, respectively. Experimental results on the emerging SiC MOSFETs at sea level and room temperature show that the 1.7kV/2kA SiC MOSFETs have to derate to 1.1kV to meet the failure rate of 100 FIT [118]. For aircraft MVDC systems, to meet the reliability requirements at high altitudes, high-voltage (e.g., 3.3kV) semiconductor devices may have to be used, which may exhibit relatively higher device losses than low-voltage devices (e.g., 1.2 kV and 1.7 kV). Multi-objective design optimization should be conducted by targeting both high efficiency, high power density, high reliability, and low cost for high-altitude aircraft applications.

V. ROADMAP TOWARD AIRCRAFT ELECTRIC PROPULSION

Throughout this article, the current state-of-the-art and challenges for electric machines and power converters have been detailed. Fig. 13 illustrates the projected roadmap toward more electric aircraft powertrains. The main technical challenges to be addressed during this roadmap includes the power density improvement of the batteries, electric machines, and power electronics design at medium voltage, e.g., ≥ 1 kV, for the high-altitude environment, with the consideration of the thermal management, insulation deratings, and high-reliability requirements [119], [120].

More specifically, Fig. 13(a) depicts the timeline of each technology's specific targets, i.e., electric energy storage, electric machines, and power converters; thus, demonstrating the critical milestones that each technology must achieve to enable the next generation of more electric powertrains-based aircraft effectively. Similarly, Fig. 13(b) shows how each technological target translates into a specific aircraft prototype using the same base timeline in terms of their electric propulsion power according to NASA [52], [121]. As can be seen, the propulsion powers tend to increase from hundreds of kilowatts for small aircraft such as flying cars or air taxis up to tens of megawatts for large twin-aisle aircraft in the next decades. It should be noted that this projected timeline is based on an achievement of Technical Readiness Level (TRL) 6, which may take a longer time to be employed in a high-altitude real-world operational environment.

Lastly, a few industry-based research prototype examples of aircraft equipped with more electric powertrains are outlined in Table IV [122], [123]. One example to highlight is the N3-X model designed by NASA for 300 passengers with a fully superconducting turboelectric powertrain that can provide up to 70% fuel savings [124]. On the other hand, single-aisle aircraft designs as the ones presented in [125], [126] can achieve fuel savings of up to 10%; while, several turboelectric aircraft concepts can be consulted in [127]–[129]. Likewise, recent single/twin passenger solar-powered aircraft have reached the technological maturity to achieve longer flight times, such as the Solar Impulse airplane, which traveled around the world using only solar energy and with a maximum flight time of almost 118 hours in one of the intervals [130], [131]. Similarly, in 2016, the Eraole hybrid-electric aircraft successfully completed its first flight using a hybrid solar propulsion scheme enabled by biofuel and solar energy [132].

VI. CONCLUSION

This review article outlined the road to the more electric aircraft powertrain. The challenges and roadblocks to achieving a more electric powertrain have been discussed, focusing on the possible powertrain architectures (i.e., all-electric, hybrid, and turboelectric) that can be feasible in the next 20 years given the energy/power density limitations of the state-of-the-art energy storage systems. Due to these limitations, the turboelectric architecture has been identified as the transitional architecture towards hybrid and all-electric powertrains.

TABLE IV
PERFORMANCE MATRIX FOR COMMERCIAL ELECTRIC AIRCRAFT POWERTRAIN ARCHITECTURES CURRENTLY UNDER STUDY [122], [123]

Aircraft Study	Propulsion	Passenger No.	Speed (Mach)	Electric Power (MW)	Fuel Burn Reduction	TRL*4-6 Timeline
NASA STARC-ABL	Partial Turboelectric	154	0.80	2 to 3	7-12%	2025
Boeing SUGAR Freeze	Partial Turboelectric (Fuel Cell)	154	0.70	N/A	56%	2030
NASA N3-X	Turboelectric	300	0.84	50	70%	2030
Boeing SUGAR Volt	Parallel Hybrid Electric	154	0.70	1.3 to 5.3	60%	2025
Rolls-Royce	Parallel Hybrid Electric	154	0.70	1 to 2.6	28%	N/A
UTRC (Raytheon)	Parallel Hybrid Electric	154	0.70	2.1	6%	N/A
Airbus/Siemens/Rolls-Royce/E-Fan X	Series Hybrid	100	N/A	2	N/A	2030
WrightElectric/EasyJet	All-Electric	120	N/A	0.78	N/A	2027

* TRL: Technology Readiness Level

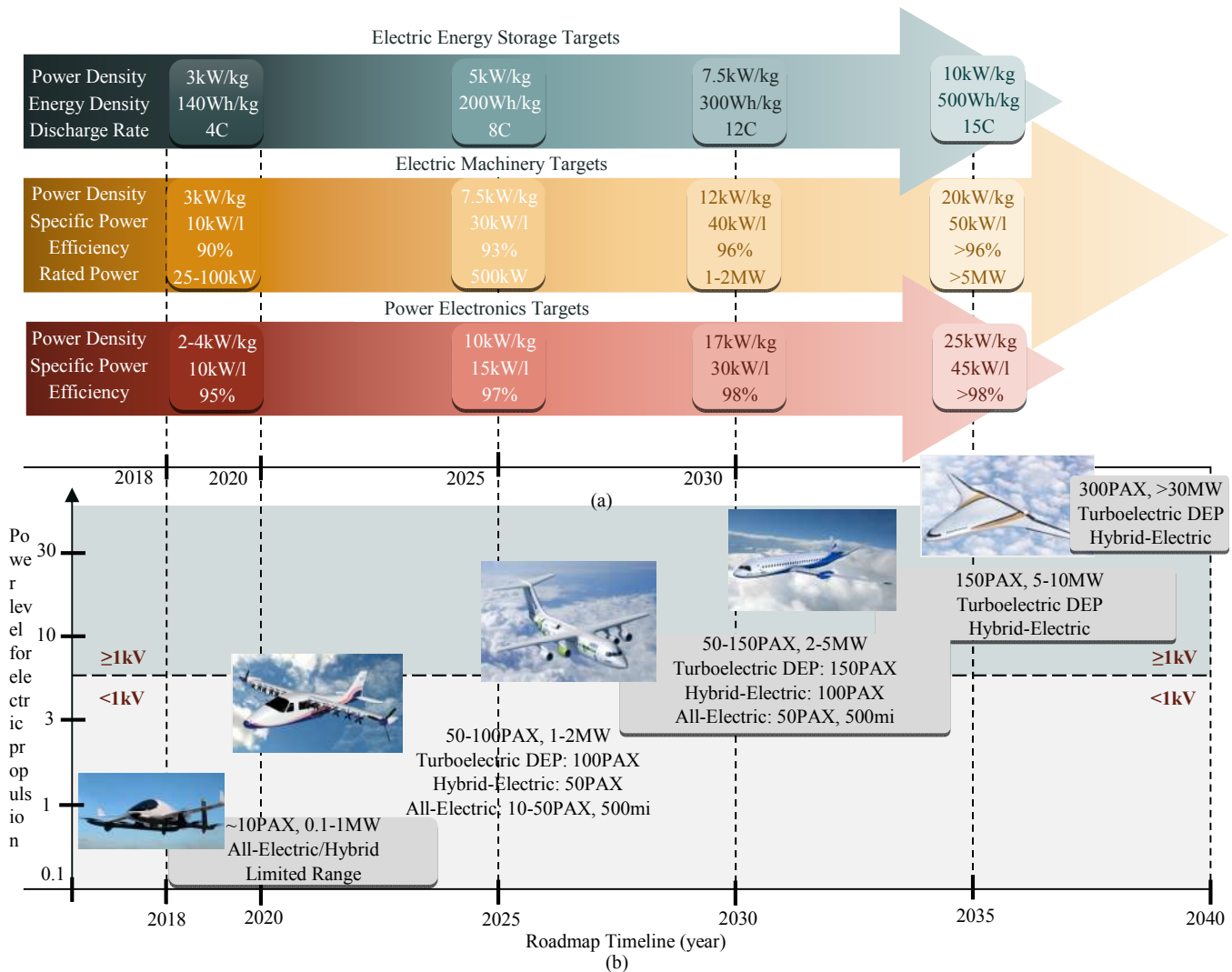

Fig. 13. Projected roadmap toward more electric aircraft powertrains; (a) technological targets roadmap, and (b) roadmap of aircraft electrification in terms of power level of electric propulsion [53], [122].

At the center of this technological transition, the necessity for high-power density MW electric machines has been analyzed, demonstrating the importance of researching radial and axial PM machines while showcasing the promising high-power densities achieved by state-of-the-art AFPM. However, AFPM motor developments have been mainly targeted for low power range (hundreds of kW range), due to the limited current carrying capability of the stator windings. Additionally, superconducting machines have been developed with high efficiency and high power-density, but perhaps more applicable for large-power powertrain systems in the range of tens of MW, due to the additional weight and physical volume with the cryostat and cooling systems. Furthermore, the thermal management of the onboard electric machines has been discussed and identified as a vital component when attempting to achieve high-power density for MW machines.

In addition to high-power electric machines, power converters have been presented as another key component enabling more electric aircraft powertrains. Several power converter topologies that have been utilized or investigated for MEA applications have been reviewed, highlighting the implementation of novel topologies and the applications of SiC and GaN semiconductors. These devices are expected to

increase the power density and efficiency of future power converters, given their low conduction/switching losses at high switching frequency. Nonetheless, the reliability and EMI of wide bandgap-enabled converters must be addressed to satisfy the rigid requirements of aerospace standards.

Beyond electric machines and power converters, MVDC powertrains for aircraft have been identified as the next step to further improve the power density and efficiency of the aircraft, especially for large wide-body airplanes where the power cable weight onboard accounts for a substantial percentage. Nonetheless, challenges such as high-altitude insulation stress, fast fault protection, and cosmic radiation impact on high-voltage semiconductors and power components at high-altitude low-pressure environments still need to be addressed before considering MVDC powertrain systems a reality in the aerospace industry. New standards and certifications must also be developed to accelerate the commercialization of hybrid and all-electric aircraft powertrains.

From a proactive engineering and research perspective, in addition to improving the performance of the individual power component such as electric machines and power converters, multi-disciplinary systematic design optimization might be an

important trend for future powertrain development, where the key factors in electrical, magnetic, mechanical, material, thermal, and aerodynamic domains can be considered comprehensively with the flight mission profiles of the aircraft. Multiphysics co-simulations integrated with multi-time-scale analysis can be leveraged as the preliminary design platforms, followed by hardware-in-the-loop and all-hardware verifications during the development process.

Lastly, the outcomes presented in this review article can be summarized as follows:

- Based on the current state-of-the-art research trends, energy storage systems are expected to enable electric flight within the next 20 years.
- Turboelectric powertrains with distributed electric propulsion are set to lead the effort toward more electric powertrains in aircraft.
- AFPM provide sufficient power density and efficiency levels to power low-passenger/single-aisle aircraft.
- Superconducting machines may be the favored alternative for twin-aisle aircraft with MW propulsion if their thermal management requirements are improved.
- High-power density wideband-gap-enabled power converters have been identified as the preferred research path for aerospace applications.
- MVDC powertrain architectures have been identified to be the enablers of more electric powertrains for large body aircraft with MW requirements.

REFERENCES

- [1] National Academies of Sciences, Engineering, and Medicine and others, *Commercial aircraft propulsion and energy systems research: reducing global carbon emissions*. National Academies Press, 2016.
- [2] B. Sarlioglu and C. T. Morris, "More Electric Aircraft: Review, Challenges, and Opportunities for Commercial Transport Aircraft," *IEEE Trans. Transp. Electrification*, vol. 1, no. 1, pp. 54–64, 2015.
- [3] K. Rajashekara, "More Electric Aircraft Trends [Technology Leaders]," *IEEE Electrification Mag.*, vol. 2, no. 4, pp. 4–39, 2014.
- [4] K. J. Karimi, "Future Aircraft Power Systems-Integration Challenges," The Boeing Company, 2007.
- [5] J. Hale, "Boeing 787 from the ground up," *Aero*, vol. 4, no. 24, p. 7, 2006.
- [6] Y. Wang, S. Nuzzo, H. Zhang, W. Zhao, C. Gerada, and M. Galea, "Challenges and Opportunities for Wound Field Synchronous Generators in Future More Electric Aircraft," *IEEE Trans. Transp. Electrification*, p. 1, 2020.
- [7] J. Serafini, M. Cremaschini, G. Bernardini, L. Solero, C. Ficuciello, and M. Gennaretti, "Conceptual All-Electric Retrofit of Helicopters: Review, Technological Outlook, and a Sample Design," *IEEE Trans. Transp. Electrification*, vol. 5, no. 3, pp. 782–794, 2019.
- [8] X. Zhang, C. L. Bowman, T. C. O'Connell, and K. S. Haran, "Large electric machines for aircraft electric propulsion," *IET Electr. Power Appl.*, vol. 12, no. 6, pp. 767–779, 2018.
- [9] I. Boldea, L. N. Tutelea, L. Parsa, and D. Dorrell, "Automotive Electric Propulsion Systems With Reduced or No Permanent Magnets: An Overview," *IEEE Trans. Ind. Electron.*, vol. 61, no. 10, pp. 5696–5711, 2014.
- [10] S. C. Davis and R. G. Boundy, "Transportation energy data book," Oak Ridge National Laboratory, 2019.
- [11] A. Emadi, Y. J. Lee, and K. Rajashekara, "Power Electronics and Motor Drives in Electric, Hybrid Electric, and Plug-In Hybrid Electric Vehicles," *IEEE Trans. Ind. Electron.*, vol. 55, no. 6, pp. 2237–2245, 2008.
- [12] A. Adib *et al.*, "E-Mobility - Advancements and Challenges," *IEEE Access*, vol. 7, pp. 165226–165240, 2019.
- [13] K. Rajashekara, "Parallel between More Electric Aircraft and Electric/Hybrid Vehicle Power Conversion Technologies," *IEEE Electrification Mag.*, vol. 2, no. 2, pp. 50–60, 2014.
- [14] X. Roboam, B. Sareni, and A. D. Andrade, "More Electricity in the Air: Toward Optimized Electrical Networks Embedded in More-Electrical Aircraft," *IEEE Ind. Electron. Mag.*, vol. 6, no. 4, pp. 6–17, 2012.
- [15] P. Wheeler and S. Bozhko, "The More Electric Aircraft: Technology and challenges," *IEEE Electrification Mag.*, vol. 2, no. 4, pp. 6–12, 2014.
- [16] W. Cao, B. C. Mecrow, G. J. Atkinson, J. W. Bennett, and D. J. Atkinson, "Overview of Electric Motor Technologies Used for More Electric Aircraft (MEA)," *IEEE Trans. Ind. Electron.*, vol. 59, no. 9, pp. 3523–3531, 2012.
- [17] V. Madonna, P. Giangrande, and M. Galea, "Electrical Power Generation in Aircraft: Review, Challenges, and Opportunities," *IEEE Trans. Transp. Electrification*, vol. 4, no. 3, pp. 646–659, 2018.
- [18] G. Buticchi, S. Bozhko, M. Liserre, P. Wheeler, and K. Al-Haddad, "On-Board Microgrids for the More Electric Aircraft-Technology Review," *IEEE Trans. Ind. Electron.*, vol. 66, no. 7, pp. 5588–5599, 2019.
- [19] A. Misra, "Energy Storage for Electrified Aircraft: The Need for Better Batteries, Fuel Cells, and Supercapacitors," *IEEE Electrification Mag.*, vol. 6, no. 3, pp. 54–61, 2018.
- [20] N. Keshmiri, D. Wang, B. Agrawal, R. Hou, and A. Emadi, "Current Status and Future Trends of GaN HEMTs in Electrified Transportation," *IEEE Access*, p. 1, 2020.
- [21] S. Farokhi, *Aircraft Propulsion*, 2nd ed. Wiley, 2014.
- [22] J. Benzaquen Sune, "Smart three-phase power converter for more electric powertrains," PhD diss. Kansas State University, 2020.
- [23] S. Kwak, T. Kim, and G. Park, "Phase-redundant-based reliable direct AC/AC converter drive for series hybrid off-highway heavy electric vehicles," *IEEE Trans. Veh. Technol.*, vol. 59, no. 6, pp. 2674–2688, Jul. 2010.
- [24] H. D. Kim, A. T. Perry, and P. J. Ansell, "A review of distributed electric propulsion concepts for air vehicle technology," in *2018 AIAA/IEEE Electric Aircraft Technologies Symposium (EATS)*, 2018, pp. 1–21.
- [25] A. S. Gohardani, G. Doulgeris, and R. Singh, "Challenges of future aircraft propulsion: A review of distributed propulsion technology and its potential application for the all electric commercial aircraft," *Prog. Aerosp. Sci.*, vol. 47, no. 5, pp. 369–391, 2011.
- [26] I. Gaspari, Fabrizio, Trainelli, Lorenzo, Rolando, Alberto, Perkon, "D1.1: Concept of Modular Architecture for Hybrid Electric Propulsion of Aircraft," Nov. 2017.
- [27] M. A. Hannan, M. M. Hoque, A. Hussain, Y. Yusof, and P. J. Ker, "State-of-the-Art and Energy Management System of Lithium-Ion Batteries in Electric Vehicle Applications: Issues and Recommendations," *IEEE Access*, vol. 6, pp. 19362–19378, 2018.
- [28] C. Spanos, D. E. Turney, and V. Fthenakis, "Life-cycle analysis of flow-assisted nickel zinc-, manganese dioxide-, and valve-regulated lead-acid batteries designed for demand-charge reduction," *Renew. Sustain. Energy Rev.*, vol. 43, pp. 478–494, 2015.
- [29] M. García-Plaza, D. Serrano-Jiménez, J. E.-G. Carrasco, and J. Alonso-Martínez, "A Ni-Cd battery model considering state of charge and hysteresis effects," *J. Power Sources*, vol. 275, pp. 595–604, 2015.
- [30] Y. Zhu, W. H. Zhu, Z. Davis, and B. J. Tatarchuk, "Simulation of Ni-MH batteries via an equivalent circuit model for energy storage applications," *Adv. Phys. Chem.*, vol. 2016, 2016.
- [31] Q. Lai, H. Zhang, X. Li, L. Zhang, and Y. Cheng, "A novel single flow zinc-bromine battery with improved energy density," *J. Power Sources*, vol. 235, pp. 1–4, 2013.
- [32] A. Fotouhi, D. J. Auger, K. Propp, S. Longo, and M. Wild, "A review on electric vehicle battery modelling: From Lithium-Ion toward Lithium-Sulphur," *Renew. Sustain. Energy Rev.*, vol. 56, pp. 1008–1021, 2016.
- [33] M. T. Sougrati *et al.*, "Transition-Metal Carbodiimides as Molecular Negative Electrode Materials for Lithium-and Sodium-Ion Batteries with Excellent Cycling Properties," *Angew. Chemie Int. Ed.*, vol. 55, no. 16, pp. 5090–5095, 2016.
- [34] U.S. Department of Energy's Bioenergy Technologies Office (BETO), "Alternative Aviation Fuels: Overview of Challenges, Opportunities, and Next Steps," 2016. Accessed: Oct. 22, 2020. [Online]. Available: https://www.energy.gov/sites/prod/files/2017/03/f34/alternative_aviation_fuels_report.pdf.

- [35] W.-C. Wang *et al.*, “Review of Biojet Fuel Conversion Technologies,” National Renewable Energy Laboratory (NREL), Jul. 2016. Accessed: Oct. 22, 2020. [Online]. Available: <https://www.nrel.gov/docs/fy16osti/66291.pdf>.
- [36] T. C. Cano *et al.*, “Future of Electrical Aircraft Energy Power Systems: An architecture review,” *IEEE Trans. Transp. Electrification*, 2021.
- [37] J. Harikumaran *et al.*, “Failure Modes and Reliability Oriented System Design for Aerospace Power Electronic Converters,” *IEEE Open J. Ind. Electron. Soc.*, vol. 2, pp. 53–64, Dec. 2020.
- [38] T. M. Jahns, “Electrified Aviation: Are Motor Drives Ready to Spread Their Wings and Fly?,” in *2019 International Aegean Conference on Electrical Machines and Power Electronics (ACEMP) 2019 International Conference on Optimization of Electrical and Electronic Equipment (OPTIM)*, 2019, pp. 16–17.
- [39] Z. Xu, D. Zhang, F. (Wang, and D. Boroyevich, “A Unified Control for the Combined Permanent Magnet Generator and Active Rectifier System,” *IEEE Trans. Power Electron.*, vol. 29, no. 10, pp. 5644–5656, 2014.
- [40] D. M. Miao, Y. Mollet, J. Gyselinck, and J. X. Shen, “DC Voltage Control of a Wide-Speed-Range Permanent-Magnet Synchronous Generator System for More Electric Aircraft Applications,” in *2016 IEEE Vehicle Power and Propulsion Conference (VPPC)*, 2016, pp. 1–6.
- [41] F. Gao, X. Zheng, S. Bozhko, C. I. Hill, and G. Asher, “Modal Analysis of a PMSG-Based DC Electrical Power System in the More Electric Aircraft Using Eigenvalues Sensitivity,” *IEEE Trans. Transp. Electrification*, vol. 1, no. 1, pp. 65–76, 2015.
- [42] W. U. N. Fernando, M. Barnes, and O. Marjanovic, “Direct drive permanent magnet generator fed AC-DC active rectification and control for more-electric aircraft engines,” *IET Electr. Power Appl.*, vol. 5, no. 1, pp. 14–27, 2011.
- [43] S. G. Burrow, P. H. Mellor, P. Churn, T. Sawata, and M. Holme, “Sensorless Operation of a Permanent-Magnet Generator for Aircraft,” *IEEE Trans. Ind. Appl.*, vol. 44, no. 1, pp. 101–107, 2008.
- [44] Z. Zhang, Y. Liu, and J. Li, “A HESM-Based Variable Frequency AC Starter-Generator System for Aircraft Applications,” *IEEE Trans. Energy Convers.*, vol. 33, no. 4, pp. 1998–2006, 2018.
- [45] N. Patin, L. Vido, E. Monmasson, J. Louis, M. Gabsi, and M. Lecrivain, “Control of a Hybrid Excitation Synchronous Generator for Aircraft Applications,” *IEEE Trans. Ind. Electron.*, vol. 55, no. 10, pp. 3772–3783, 2008.
- [46] A. Nasr, S. Hlioui, M. Gabsi, M. Mairie, and D. Lalevee, “Design Optimization of a Hybrid-Excited Flux-Switching Machine for Aircraft-Safe DC Power Generation Using a Diode Bridge Rectifier,” *IEEE Trans. Ind. Electron.*, vol. 64, no. 12, pp. 9896–9904, 2017.
- [47] C. C. Chan, “The State of the Art of Electric, Hybrid, and Fuel Cell Vehicles,” *Proc. IEEE*, vol. 95, no. 4, pp. 704–718, 2007.
- [48] E. Silvas, T. Hofman, N. Murgovski, L. F. P. Etmann, and M. Steinbuch, “Review of Optimization Strategies for System-Level Design in Hybrid Electric Vehicles,” *IEEE Trans. Veh. Technol.*, vol. 66, no. 1, pp. 57–70, 2017.
- [49] B. Poudel, E. Amiri, P. Rastgoufard, and B. Mirafzal, “Toward Less Rare-Earth Permanent Magnet in Electric Machines: A Review,” *IEEE Trans. Magn.*, pp. 1–1, 2021.
- [50] S. Li, B. Sarlioglu, S. Jurkovic, N. R. Patel, and P. Savagian, “Analysis of Temperature Effects on Performance of Interior Permanent Magnet Machines for High Variable Temperature Applications,” *IEEE Trans. Ind. Appl.*, vol. 53, no. 5, pp. 4923–4933, 2017.
- [51] A. El-Refaie and M. Osama, “High specific power electrical machines: A system perspective,” *CES Trans. Electr. Mach. Syst.*, vol. 3, no. 1, pp. 88–93, 2019.
- [52] R. Dyson, “NASA Hybrid Electric Aircraft Propulsion,” Cleveland, Oct. 2017. Accessed: Oct. 21, 2020. [Online]. Available: <https://www.grc.nasa.gov/vine/wp-content/uploads/sites/91/Rodger-Dyson-NASA-Hybrid-Electric-Aircraft-Propulsion-10-4-2017-FULL.pdf>.
- [53] K. Sitapati and R. Krishnan, “Performance comparisons of radial and axial field, permanent-magnet, brushless machines,” *IEEE Trans. Ind. Appl.*, vol. 37, no. 5, pp. 1219–1226, 2001.
- [54] J. W. Connolly, J. W. Chapman, E. J. Stalcup, K. R. Hunker, A. K. Chicatelli, and G. L. Thomas, “Modeling and Control Design for a Turboelectric Single Aisle Aircraft Propulsion System,” *2018 AIAA/IEEE Electr. Aircr. Technol. Symp. EATS 2018*, 2018.
- [55] F. Giulii Capponi, G. De Donato, and F. Caricchi, “Recent Advances in Axial-Flux Permanent-Magnet Machine Technology,” *IEEE Trans. Ind. Appl.*, vol. 48, no. 6, pp. 2190–2205, 2012.
- [56] A. Cavagnino, M. Lazzari, F. Profumo, and A. Tenconi, “A comparison between the axial flux and the radial flux structures for PM synchronous motors,” *IEEE Trans. Ind. Appl.*, vol. 38, no. 6, pp. 1517–1524, 2002.
- [57] F. Crescimbeni, A. Di Napoli, L. Solero, and F. Caricchi, “Compact permanent-magnet generator for hybrid vehicle applications,” *IEEE Trans. Ind. Appl.*, vol. 41, no. 5, pp. 1168–1177, 2005.
- [58] “EVO Axial Flux Electric Motors.” [Online]. Available: <https://avidtp.com/product/evo-motors/>.
- [59] “Manual for EMRAX Motors / Generators.” [Online]. Available: https://emrax.com/wp-content/uploads/2020/03/manual_for_emrax_motors_version_5.4.pdf.
- [60] “The Technology: Next-Gen Axial Flux Machines.” [Online]. Available: <https://www.magnax.com/technology>.
- [61] M. Corduan, M. Boll, R. Bause, M. P. Oomen, M. Filipenko, and M. Noe, “Topology Comparison of Superconducting AC Machines for Hybrid Electric Aircraft,” *IEEE Trans. Appl. Supercond.*, vol. 30, no. 2, pp. 1–10, 2020.
- [62] J. J. Scheidler, “Preliminary Design of the Superconducting Rotor for NASA’s High-Efficiency Megawatt Motor,” *AIAA Propuls. Energy Forum*, 2018.
- [63] R. Sugouchi *et al.*, “Conceptual Design and Electromagnetic Analysis of 2 MW Fully Superconducting Synchronous Motors with Superconducting Magnetic Shields for Turbo-Electric Propulsion System,” *IEEE Trans. Appl. Supercond.*, vol. 30, no. 4, 2020.
- [64] S. Du, J. Tangudu, and P. Kshirsagar, “Analytical model and design space studies for a non-superconducting and superconducting electric machine for an aircraft application,” 2020.
- [65] H. Karmaker, D. Sarandria, M. T. Ho, J. Feng, D. Kulkarni, and G. Rupertus, “High-Power Dense Electric Propulsion Motor,” *IEEE Trans. Ind. Appl.*, vol. 51, no. 2, pp. 1341–1347, 2015.
- [66] John Yagielski, “Electric Motors for Hybrid/Electric Aviation – Technology Developments & Challenges,” *GE GLOBAL RESEARCH*, Aug. 2019. https://arpa-e.energy.gov/sites/default/files/6_GE_ARPA-e_Electric_Motors_Presentation_8-8_rev8.pdf (accessed Oct. 21, 2020).
- [67] C. Dong, Y. Qian, Y. Zhang, and W. Zhuge, “A Review of Thermal Designs for Improving Power Density in Electrical Machines,” *IEEE Trans. Transp. Electrification*, vol. 6, no. 4, pp. 1386–1400, Dec. 2020.
- [68] Z. Xu *et al.*, “A semi-flooded cooling for a high speed machine: Concept, design and practice of an oil sleeve,” in *Proceedings IECON 2017 - 43rd Annual Conference of the IEEE Industrial Electronics Society*, Dec. 2017, vol. 2017-January, pp. 8557–8562.
- [69] A. La Rocca, S. J. Pickering, C. Eastwick, and C. Gerada, “Enhanced cooling for an electric starter-generator for aerospace application,” in *IET Conference Publications*, 2014, vol. 2014, no. 628 CP.
- [70] C. Liu *et al.*, “Experimental Investigation on Oil Spray Cooling with Hairpin Windings,” *IEEE Trans. Ind. Electron.*, vol. 67, no. 9, pp. 7343–7353, Sep. 2020.
- [71] S. A. Semidey and J. R. Mayor, “Experimentation of an electric machine technology demonstrator incorporating direct winding heat exchangers,” *IEEE Trans. Ind. Electron.*, vol. 61, no. 10, pp. 5771–5778, 2014.
- [72] M. Schiefer and M. Doppelbauer, “Indirect slot cooling for high-power-density machines with concentrated winding,” in *Proceedings - 2015 IEEE International Electric Machines and Drives Conference, IEMDC 2015*, Feb. 2016, pp. 1820–1825.
- [73] M. Polikarpova, P. Lindh, C. Gerada, M. Rilla, V. Naumanen, and J. Pyrhönen, “Thermal effects of stator potting in an axial-flux permanent magnet synchronous generator,” *Appl. Therm. Eng.*, vol. 75, pp. 421–429, 2015.
- [74] Y. Sun, S. Zhang, W. Yuan, Y. Tang, J. Li, and K. Tang, “Applicability study of the potting material based thermal management strategy for permanent magnet synchronous motors,” *Appl. Therm. Eng.*, vol. 149, pp. 1370–1378, Feb. 2019.
- [75] M. Galea, C. Gerada, T. Raminosa, and P. Wheeler, “A Thermal Improvement Technique for the Phase Windings of Electrical Machines,” vol. 48, no. 1, pp. 79–87, 2012.
- [76] X. Zhang, C. Zhang, P. Fu, C. Zhang, and L. Li, “A Novel Cooling Technique for the Windings of High-Torque-Density Permanent Magnet

- Machines,” in *ICEMS 2018 - 2018 21st International Conference on Electrical Machines and Systems*, Nov. 2018, pp. 332–337.
- [77] A. S. Fawzal, R. M. Cirstea, K. N. Gyftakis, T. J. Woolmer, M. Dickison, and M. Blundell, “Fan Performance Analysis for Rotor Cooling of Axial Flux Permanent Magnet Machines,” *IEEE Trans. Ind. Appl.*, vol. 53, no. 4, pp. 3295–3304, Jul. 2017.
- [78] K. H. Lee, H. R. Cha, and Y. B. Kim, “Development of an interior permanent magnet motor through rotor cooling for electric vehicles,” *Appl. Therm. Eng.*, vol. 95, pp. 348–356, Feb. 2016.
- [79] J. Huang *et al.*, “A Hybrid Electric Vehicle Motor Cooling System-Design, Model, and Control,” *IEEE Trans. Veh. Technol.*, vol. 68, no. 5, pp. 4467–4478, 2019.
- [80] D. Christen, U. Badstuebner, J. Biela, and J. W. Kolar, “Calorimetric power loss measurement for highly efficient converters,” in *2010 International Power Electronics Conference - ECCE Asia - IPEC 2010*, 2010, pp. 1438–1445.
- [81] T. Hassett and M. Hodowanec, “Electric motor with heat pipes,” US 7,569,955 B2, 2009.
- [82] E. Sayed *et al.*, “Review of Electric Machines in More/Hybrid/Turbo Electric Aircraft,” *IEEE Trans. Transp. Electrification*, pp. 1–1, Jun. 2021.
- [83] A. Lidow, J. Strydom, R. Strittmatter, and C. Zhou, “GaN: A Reliable Future in Power Conversion: Dramatic performance improvements at a lower cost,” *IEEE Power Electron. Mag.*, vol. 2, no. 1, pp. 20–26, 2015.
- [84] J. Millán and others, “A Survey of Wide Bandgap Power Semiconductor Devices,” *IEEE Trans. Power Electron.*, vol. 29, no. 5, pp. 2155–2163, 2014.
- [85] GE Aviation, “Power Conversion and Control Products.” <https://www.geaviation.com/sites/default/files/power-conversion-control-products.pdf> (accessed Oct. 21, 2020).
- [86] P. Ning *et al.*, “High-temperature hardware: Development of a 10-kW high-temperature, high-power-density three-phase ac-dc-ac SiC converter,” *IEEE Ind. Electron. Mag.*, 2013.
- [87] D. Han, A. Ogale, S. Li, Y. Li, and B. Sarlioglu, “Efficiency characterization and thermal study of GaN based 1 kW inverter,” in *2014 IEEE Applied Power Electronics Conference and Exposition - APEC 2014*, 2014, pp. 2344–2350.
- [88] J. He *et al.*, “Multi-Domain Design Optimization of dv/dt Filter for SiC-Based Three-Phase Inverters in High-Frequency Motor-Drive Applications,” *IEEE Trans. Ind. Appl.*, vol. 55, no. 5, pp. 5214–5222, 2019.
- [89] RTCA-DO-160, “Environmental Conditions and Test Procedures for Airborne Equipment,” *Federal Aviation Administration (FAA)*. 2011.
- [90] B. Singh, B. N. Singh, A. Chandra, K. Al-Haddad, A. Pandey, and D. P. Kothari, “A review of three-phase improved power quality AC-DC converters,” *IEEE Trans. Ind. Electron.*, vol. 51, no. 3, pp. 641–660, 2004.
- [91] J. W. Kolar and T. Friedli, “The Essence of Three-Phase PFC Rectifier Systems - Part I,” *IEEE Trans. Power Electron.*, vol. 28, no. 1, pp. 176–198, 2013.
- [92] T. Friedli, M. Hartmann, and J. W. Kolar, “The Essence of Three-Phase PFC Rectifier Systems - Part II,” *IEEE Trans. Power Electron.*, vol. 29, no. 2, pp. 543–560, 2014.
- [93] J. Benzaquen, F. Fateh, M. B. Shadmand, and B. Mirafzal, “Performance Comparison of Active Rectifier Control Schemes in More Electric Aircraft Applications,” *IEEE Trans. Transp. Electrification*, vol. 5, no. 4, pp. 1470–1479, 2019.
- [94] G. Gong, M. L. Heldwein, U. Drogenik, J. Minibock, K. Mino, and J. W. Kolar, “Comparative evaluation of three-phase high-power-factor AC-DC converter concepts for application in future More Electric Aircraft,” *IEEE Trans. Ind. Electron.*, vol. 52, no. 3, pp. 727–737, 2005.
- [95] J. Benzaquen, F. Fateh, and B. Mirafzal, “On the Dynamic Performance of Variable-Frequency AC-DC Converters,” *IEEE Trans. Transp. Electrification*, vol. 6, no. 2, pp. 530–539, 2020.
- [96] J. Benzaquen and B. Mirafzal, “Seamless Dynamics for Wild-Frequency Active Rectifiers in More Electric Aircraft,” *IEEE Trans. Ind. Electron.*, vol. 67, no. 9, pp. 7135–7145, 2020.
- [97] D. Zhang, J. He, and D. Pan, “A Megawatt-Scale Medium-Voltage High-Efficiency High Power Density ‘SiC+Si’ Hybrid Three-Level ANPC Inverter for Aircraft Hybrid-Electric Propulsion Systems,” *IEEE Trans. Ind. Appl.*, vol. 55, no. 6, pp. 5971–5980, 2019.
- [98] C. Buccella *et al.*, “A Cascade Multilevel Configuration for Commercial Transport Aircraft,” *2018 110th AET Int. Annu. Conf. AET 2018*, 2018.
- [99] B. Mirafzal, “Survey of Fault-Tolerance Techniques for Three-Phase Voltage Source Inverters,” *IEEE Trans. Ind. Electron.*, vol. 61, no. 10, pp. 5192–5202, 2014.
- [100] J. W. Kolar, T. Friedli, J. Rodriguez, and P. W. Wheeler, “Review of three-phase PWM AC-AC converter topologies,” *IEEE Trans. Ind. Electron.*, vol. 58, no. 11, pp. 4988–5006, 2011.
- [101] P. Wheeler *et al.*, “A matrix converter based permanent magnet motor drive for an aircraft actuation system,” in *IEEE International Electric Machines and Drives Conference, 2003. IEMDC’03.*, 2003, vol. 2, pp. 1295–1300 vol.2.
- [102] J. Lei, B. Zhou, J. Wei, X. Qin, and J. Bian, “Aircraft starter/generator system based on indirect matrix converter,” in *IECON 2014 - 40th Annual Conference of the IEEE Industrial Electronics Society*, 2014, pp. 4840–4846.
- [103] G. T. Chiang and J. Itoh, “DC/DC Boost Converter Functionality in a Three-Phase Indirect Matrix Converter,” *IEEE Trans. Power Electron.*, vol. 26, no. 5, pp. 1599–1607, 2011.
- [104] L. Dorn-Gomba, J. Ramoul, J. Reimers, and A. Emadi, “Power Electronic Converters in Electric Aircraft: Current Status, Challenges, and Emerging Technologies,” *IEEE Trans. Transp. Electrification*, 2020.
- [105] M. N. Kheraluwala, R. W. Gascoigne, D. M. Divan, and E. D. Baumann, “Performance characterization of a high-power dual active bridge DC-to-DC converter,” *IEEE Trans. Ind. Appl.*, vol. 28, no. 6, pp. 1294–1301, 1992.
- [106] R. Liu, L. Xu, Y. Kang, Y. Hui, and Y. Li, “Decoupled TAB converter with energy storage system for HVDC power system of more electric aircraft,” *J. Eng.*, vol. 2018, no. 13, pp. 593–602, Jan. 2018.
- [107] P. Gemin *et al.*, “Architecture, Voltage and Components for a Turboelectric Distributed Propulsion Electric Grid (AVC-TeDP),” 2015. Accessed: Oct. 21, 2020. [Online]. Available: <http://www.sti.nasa.gov>.
- [108] “E-Fan X - Electric flight - Airbus.” <https://www.airbus.com/innovation/zero-emission/electric-flight/e-fan-x.html> (accessed Oct. 21, 2020).
- [109] J. He, D. Zhang, and D. Torrey, “Recent Advances of Power Electronics Applications in More Electric Aircrafts,” *2018 AIAA/IEEE Electr. Aircr. Technol. Symp. EATS 2018*, 2018.
- [110] M. J. Armstrong *et al.*, “Architecture, Voltage and Components for a Turboelectric Distributed Propulsion Electric Grid,” NASA/CR—2015-218440, Jul. 2015.
- [111] D. Zhang, J. He, D. Pan, M. Schutten, and M. Dame, “High Power Density Medium-Voltage Megawatt-Scale Power Converter for Aviation Hybrid-Electric Propulsion Applications,” in *2019 IEEE Energy Conversion Congress and Exposition (ECCE)*, 2019, pp. 582–588.
- [112] I. Cotton, R. Gardner, D. Schweickart, D. Grosean, and C. Severns, “Design considerations for higher electrical power system voltages in aerospace vehicles,” in *2016 IEEE International Power Modulator and High Voltage Conference (IPMHVC)*, 2016, pp. 57–61.
- [113] L. Lusuardi and A. Cavallini, “The Problem of Altitude When Qualifying the Insulating System of Actuators for More Electrical Aircraft,” in *2018 IEEE International Conference on Electrical Systems for Aircraft, Railway, Ship Propulsion and Road Vehicles International Transportation Electrification Conference (ESARS-ITEC)*, 2018, pp. 1–4.
- [114] W. Yin *et al.*, “Highly thermally conductive insulation for high power density electric machines,” *AIAA Propuls. Energy Forum Expo. 2019*, 2019.
- [115] X. Pei and others, “A review of technologies for MVDC circuit breakers,” in *IECON 2016 - 42nd Annual Conference of the IEEE Industrial Electronics Society*, 2016, pp. 3799–3805.
- [116] N. 5SYA 2042-09 ABB Application Note, “Failure rates of IGBT modules due to cosmic rays.” 2019.
- [117] I. Zaczek, “Impact of cosmic radiation on aviation reliability and safety,” *Journal of Applied Engineering Science*. 2013.
- [118] A. Bolotnikov and others, “Overview of 1.2kV-2.2kV SiC MOSFETs targeted for industrial power conversion applications,” in *2015 IEEE Applied Power Electronics Conference and Exposition (APEC)*, 2015, pp. 2445–2452.
- [119] “Insight: 07 - Electric Power Systems.” Aerospace Technology Institute, pp. 1–16, 2018, [Online]. Available:

https://www.ati.org.uk/media/ntlocbb4/insight_07-electrical-power-systems.pdf.

- [120] Safran, "Safran and Aviation's Electric Future." Press Kit. 2019 Paris Air Show, pp. 1–17, 2019, [Online]. Available: <https://www.safran-group.com/safran-and-aviations-electric-future>.
- [121] "Safran and aviation's electric future | Safran." <https://www.safran-group.com/safran-and-aviations-electric-future> (accessed Oct. 21, 2020).
- [122] R. Jansen, C. Bowman, A. Jankovsky, R. Dyson, and J. Felder, "Overview of NASA electrified aircraft propulsion (EAP) research for large subsonic transports," in *53rd AIAA/SAE/ASEE Joint Propulsion Conference*, 2017, p. 4701.
- [123] ICAO Secretariat, "Electric, Hybrid, and Hydrogen Aircraft - State of Play," 2019.
- [124] H. D. Kim, J. L. Felder, M. T. Tong, and M. Armstrong, "Revolutionary aeropropulsion concept for sustainable aviation: turboelectric distributed propulsion," *Int. Soc. Air Breath. Engines*, 2013.
- [125] J. Welstead and J. L. Felder, "Conceptual design of a single-aisle turboelectric commercial transport with fuselage boundary layer ingestion," in *54th AIAA Aerospace Sciences Meeting*, 2016, p. 1027.
- [126] R. Jansen, C. Bowman, and A. Jankovsky, "Sizing power components of an electrically driven tail cone thruster and a range extender," in *16th AIAA Aviation Technology, Integration, and Operations Conference*, 2016, p. 3766.
- [127] E. M. Greitzer *et al.*, "N+3 aircraft concept designs and trade studies. volume 2; appendices-design methodologies for aerodynamics, structures, weight, and thermodynamic cycles," NASA Glenn Research Center, Cleveland, 2010.
- [128] A. Seitz, A. T. Isikveren, and M. Hornung, "Pre-concept performance investigation of electrically powered aero-propulsion systems," in *49th AIAA/ASME/SAE/ASEE Joint Propulsion Conference*, 2013, p. 3608.
- [129] C. Pernet, P. C. Vratny, M. Schmidt, and A. Isikveren, "Conceptual Studies of Future Hybrid-Electric Regional Aircraft," *ISABE 2015 (Awatef Hamed, Fac. Work Res. Coll. Eng. Appl. Sci.)*, 2015.
- [130] D. Lawhorn, V. Rallabandi, and D. M. Ionel, "Power Electronics Powertrain Architectures for Hybrid and Solar Electric Airplanes with Distributed Propulsion," 2018.
- [131] "Solar Impulse - Around the World to Promote Clean Technologies." <https://aroundtheworld.solarimpulse.com/adventure#zero-fuel-aircraft> (accessed Jan. 13, 2021).
- [132] "ERAOLE Hybrid electric aircraft - TYVA MODULOO." <https://tyva-moduloo.com/project/eraole-hybrid-electric-aircraft/> (accessed Jan. 13, 2021).



Joseph Benzaquen (Member, IEEE) received the B.Sc. and M.Sc. degrees in electrical engineering from Universidad Simón Bolívar, Caracas, Venezuela, in 2011 and 2015, respectively. He obtained the Ph.D. degree in electrical engineering from Kansas State University, Manhattan, KS, USA. He is currently a Postdoctoral Fellow with the Center for Distributed Energy at Georgia Institute of Technology, Atlanta, GA, USA. His research interests include grid-interactive power converters and high-performance controllers for e-mobility power converters.



Jiangbiao He (Senior Member, IEEE) is an Assistant Professor and Endowed Pigman Faculty Fellow in electric power energy area with the Department of Electrical and Computer Engineering, University of Kentucky, USA. He previously worked in industry, most recently as a Lead Engineer with GE Global Research, Niskayuna, New York. He also worked at Eaton Corporation and Rockwell Automation before he joined GE in 2015. He received the Ph.D. degree in electrical engineering from Marquette University, Wisconsin.

His research interests include high-performance propulsion drives and power converters for electric transportation, renewable energies, and fault-tolerant power conversion systems for safety-critical applications. He has authored over 100 technical papers and 10 U.S. patents in the area of power electronics and motor drives. Dr. He has served as an Editor or Associate Editor for multiple prestigious journals in electric power area. He also served in the organizing committees for numerous IEEE international conferences, and has been an active member of multiple IEEE standards working groups. He is a recipient of the 2019 AWS Outstanding Young Member Achievement Award with IEEE Industry Applications Society.



Behrooz Mirafzal (Senior Member, IEEE) received the Ph.D. degree in electrical engineering from Marquette University, Milwaukee, WI, in 2005. From 2005 to 2008, he was a Senior Development/Project Engineer with Rockwell Automation, Mequon, WI. From 2008 to 2011, he was an Assistant Professor at FIU, Miami, FL. He joined Kansas State University, Manhattan, KS, in 2011, where he is a Full Professor. His current research interests include applications of power electronics in energy conversion systems and grid-interactive converters. He is the author or a co-author of over 100 articles in professional journals and conferences and holds four U.S. patents. He is also the author of a textbook titled *Power Electronics in Energy Conversion Systems*, published by McGraw Hill in 2021. Dr. Mirafzal was a recipient of the 2008 Second Best IEEE Industry Applications Society Transactions Prize Paper Award, the Best 2012 IEEE Power and Energy Society Transactions Prize Paper Award, the 2020 Third Best IAS Renewable Committee Transactions Prize Paper Award, and the 2014 U.S. National Science Foundation (NSF) CAREER Award. He has served as an Associate Editor for the IEEE Transactions on Industry Application since 2011 and as an Associate Editor for the IEEE Transactions on Power Electronics since 2018.