

LLC Resonant Converter Topologies and Industrial Applications - A Review*

Junming Zeng¹, Guidong Zhang^{1*}, Samson Shenglong Yu², Bo Zhang³ and Yun Zhang¹

(1. School of Automation, Guangdong University of Technology, Guangzhou 510600, China;

2. School of Engineering, Deakin University, Victoria 3216, Australia;

3. School of Electric Power, South China University of Technology, Guangzhou 510640, China)

Abstract: Owing to the advantages of high efficiency, high energy density, electrical isolation, low electromagnetic interference (EMI) and harmonic pollution, magnetic integration, wide output ranges, low voltage stress, and high operation frequency, the LLC resonant converters are widely used in various sectors of the electronics-based industries. The history and development of the LLC resonant converters are presented, their advantages are analyzed, three of the most popular LLC resonant converter topologies with detailed assessments of their strengths and drawbacks are elaborated. Furthermore, an important piece of research on the industrial applications of the LLC resonant converters is conducted, mainly including electric vehicle (EV) charging, photovoltaic systems, and light emitting diode (LED) lighting drivers and liquid crystal display (LCD) TV power supplies. Finally, the future evolution of the LLC resonant converter technology is discussed.

Keywords: Electrical isolation, high energy density, LLC resonant converter, zero-current switching (ZCS) turn-off, zero-voltage switching (ZVS) turn-on

1 Introduction

The LLC resonant converter structure was first invented in 1988^[1], but due to its complicated control and intricate parameter design, it has not received enough attention, nor has it been used much in practical applications for a long time.

With the recent demand for high energy density, the switch mode power supply (SMPS) was developed to operate with higher frequencies, which is an inevitable trend in the evolution of power electronics^[2-3]. However, high-frequency means high switching energy consumption and high electromagnetic interference (EMI) pollution^[4-5]. Therefore, the resonant converters with a soft-switching function and high-frequency feature have attracted the attention and research of scholars all over the world in the most recent decade^[6]. Compared with the series LC resonant converter and the parallel LC resonant converter, the LLC resonant converter combines the advantages of

those other resonant converters, including DC isolation, stable no-load operation, low requirements on current ripple of capacitor filter and adjustment of resonant current as load, and provides advantages in the voltage adjustment and soft-switching range. Hence, scholars have started conducting extensive research on it. With the development of a large number of control integrated circuits (ICs) and substantial research on the resonant converters, the LLC resonant converters have become increasingly more mature, and have been applied in wide-ranging industrial applications.

As shown in Fig. 1, the LLC resonant converter can be divided into three parts, i.e., the square wave generation system, the resonant network and the rectifier network.

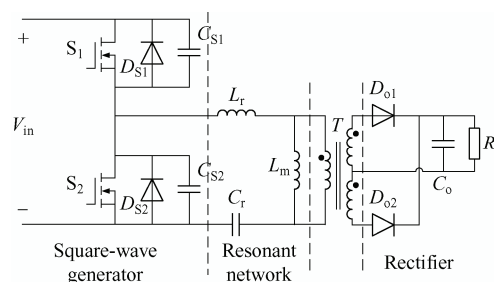

Fig. 1 The three parts of the LLC resonant converter

The square-wave generator is composed of two switches (including their body diodes and parasitic

Manuscript received May 25, 2020; revised June 6, 2020; accepted July 7, 2020. Date of publication September 30, 2020; date of current version July 20, 2020.

* Corresponding Author, E-mail: guidong.zhang@gdut.edu.cn

* Supported by the National Natural Science Foundation of China (51907032) and the Natural Science Foundation of Guangdong Province (2018A030313365).

Digital Object Identifier: 10.23919/CJEE.2020.000021

capacitors) with the complementary duty ratio of 0.5. The resonant network includes a high-frequency transformer (including resonant inductor L_r and magnetizing inductor L_m) and a resonant capacitor C_r . The rectifier network is usually composed of two or four diodes, and a capacitor filter.

As shown in Fig. 2, the LLC resonant converter is able to achieve zero-voltage switching (ZVS) turn-on by using parasite parameters [7], zero-current switching (ZCS) turn-off of the diodes at the secondary side of the transformer [8], electrical isolation from power grid [9], low EMI and harmonic pollution [10], low voltage stress [11], magnetic integration [12], and a wide-output range [13] without auxiliary equipment. Thus, it can improve the overall efficiency of the converter, prevent the load from affecting the power grid, and reduce the size and complexity of the power supply system, and is suitable for different loading conditions.

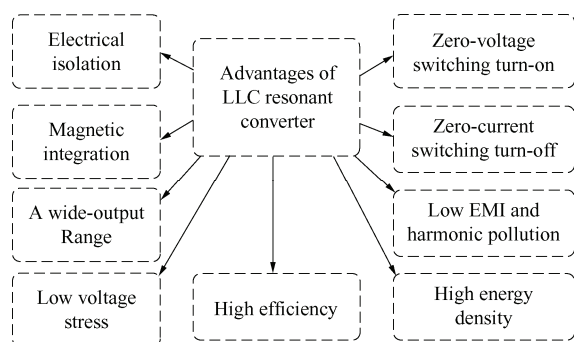

Fig. 2 Advantages of the LLC resonant converter

Due to the above mentioned advantages, the applications based on LLC resonant converters have been developed at a burgeoning rate for over ten years, including an electric vehicle (EV) charging station [14-15], laptop adapter [16], liquid crystal display (LCD) TV power supply [17], LED lighting driver [18], battery charger [19], and photovoltaic system [20]. The LLC resonant converter is mainly responsible for electrical isolation, high energy density, and soft-switching functions [21], contributing to an increased product safety, low EMI and harmonic pollution, reduced product weight, and high efficiency.

In this paper, the advantages of the LLC resonant converter will be presented and its operating principles will be analyzed. Moreover, this paper contains a comparison of the different popular structures of LLC resonant converters, an overview of the practical applications of the LLC resonant converter in various

industries, and an indication of the future development path of the LLC resonant converters.

The rest of this paper is organized as follows: Section 2 elaborates on the advantages of the LLC resonant converter; Section 3 shows the three most popular LLC resonant structures used in industrial applications; then, an overview of the LLC resonant converter applications in various industries is presented in Section 4; in Section 5, the future direction of the LLC resonant converter is presented; finally, the conclusion is presented in Section 6.

2 Advantages of the LLC resonant converter

A number of advantageous functions, which are detailed below, can be achieved in the LLC resonant converters without auxiliary circuits and special control strategies.

2.1 ZVS turn-on

When the LLC resonant converter works in the inductive region, the resonant current lags the input voltage. Thus, when the switching state is changed, the direction of the resonant current cannot be abruptly changed, and the current continues to flow in the original direction. At this time, due to the parasitic capacitors at both ends of the switches, the resonant current will discharge one of them (e.g. C_{S1}) and charge the other one (e.g. C_{S2}), as shown in Fig. 3 [22]. When the parasitic capacitor is fully discharged, the body diode (e.g. D_{S1}) is turned on. There is no intersection between the voltages and the switching current when the resonant current is reduced to zero and the switch S_1 is turned on, hence no active power is generated. Switching losses are avoided and soft-switching is achieved.

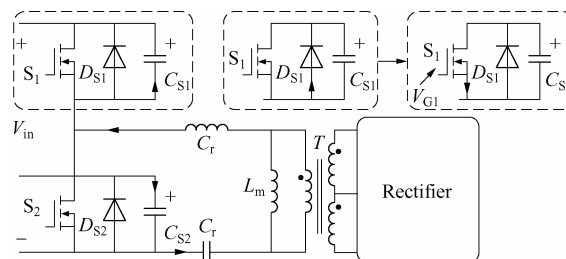

Fig. 3 Operation modes of the ZVS condition of S_1

2.2 ZCS turn-off

The magnetizing inductor in the transformer

periodically participates in the resonance, allowing for the ZCS. As shown in Fig. 4, when the magnetizing inductor does not take part in the resonance, the resonant current flows into both the magnetizing inductor and primary side of the transformer, and the magnetizing inductor is clamped by output voltage across the diode. Therefore, the diode is turned on and the energy is transferred from the power source to the load. When the resonant current is equal to the current flowing through the magnetizing inductor, no current flows through the primary side of the transformer, and the diode rectifier on the secondary side of the transformer is turned off due to the reverse voltage. Therefore, the magnetizing inductor participates in the resonance, which creates a period that avoids the simultaneous conduction of two diodes, avoiding the reverse recovery effect of the diodes. Thus ZCS protects the switching devices and improves the stability and efficiency of the LLC resonant converter.

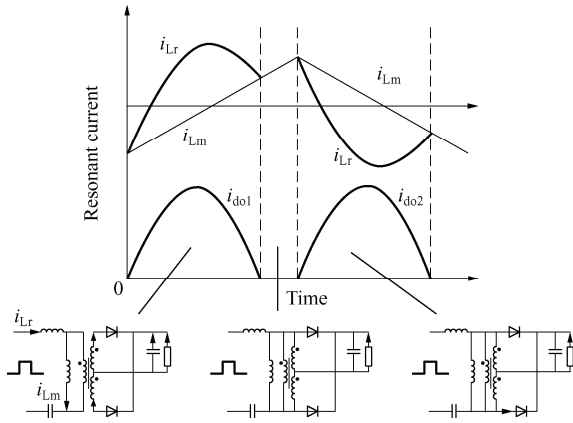

Fig. 4 Operation modes of the ZCS condition

2.3 High efficiency

The LLC resonant converter can realize both ZVS and ZCS, reducing switching losses and avoiding the reverse recovery effect of the diodes. Therefore, the losses of all switching components are reduced, thus improving the overall efficiency of the converter.

2.4 Magnetic integration

Since the magnetizing inductor and resonant inductor are integrated in the high-frequency transformer, as shown in Fig. 5, the leakage inductor is fully utilized in the LLC resonant converter^[23], so that the LLC resonant converter can not only achieve electrical isolation and voltage conversion, but also save the

inductor costs, reducing the overall size of the converter and increasing the energy density.

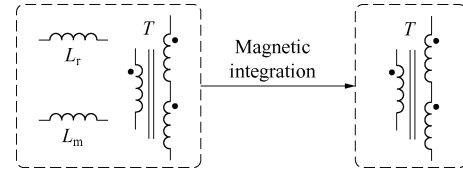

Fig. 5 Magnetic integration of the resonant inductor, magnetizing inductor and transformer

2.5 High energy density

Due to the high switching frequency, the transformer volume can be reduced. Besides, the magnetizing inductor and resonant inductor are integrated in the transformer, so the LLC resonant converter is able to achieve a high energy density.

2.6 Electrical isolation

Due to the use of the high-frequency transformer, the LLC resonant converter isolates the load from the power supply. Therefore, the load cannot affect the power grid, which prevents it from polluting the power grid.

2.7 A wide output range

The LLC resonant converter can change the switching frequency by pulse frequency modulation (PFM) control, and then change the impedance of the resonant elements, so that the gain is changed to regulate the output according to the gain expression of the LLC resonant converter

$$G_{LLC}(s) = \frac{\frac{8n^2}{\pi^2} R_o // sL_m}{\frac{1}{sC_r} + sL_r + \frac{8n^2}{\pi^2} R_o // sL_m}$$

where n is the turns ratio of the transformer; R_o is the load; C_r is the resonant capacitor value; L_r is the resonant inductor value; L_m is the magnetizing inductor value.

In this way, the LLC resonant converter can work in different loading conditions. Even if the load changes suddenly or the voltage source experiences a certain failure, the LLC resonant converter can also adjust the output voltage or output current by PFM control to ensure operating stability and enhance its adaptability.

2.8 Low EMI and harmonic pollution

Because the waveform of the resonant current is close to a sinusoidal wave, there is no voltage and current spike on the diode rectifier, which means that the LLC resonant converter has excellent electromagnetic compatibility and low EMI and harmonic pollution.

2.9 Low voltage stress

As the magnetizing inductor plays a filtering role, an inductor filter is removed in the secondary side of the transformer, and the voltage stress of the diode rectifier is reduced.

3 Three popular LLC resonant structures used in industrial applications

The LLC resonant converter has several main structures used in industry applications, including the half-bridge LLC resonant converter, the full-bridge LLC resonant converter, and the three-level (TL) LLC resonant converter.

3.1 Half-bridge LLC resonant converter

As shown in Fig. 6, the half-bridge LLC resonant converter is composed of two switches, resonant components, two diodes, and an output capacitor. The half-bridge LLC resonant converter is always applied to the conditions with high input voltage and low input current, and low output voltage and high output current. This topology is widely used in EV charging stations, LED lighting drivers, on-board power grid, LCD TV power supplies, computer and communication power supplies, microwave power supplies, battery chargers, and wireless heating systems.

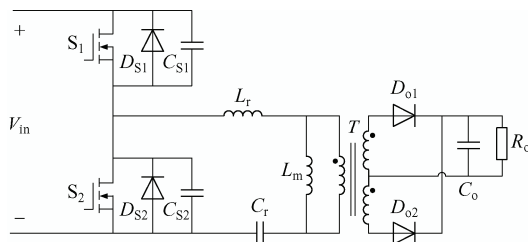

Fig. 6 The half-bridge LLC resonant converter topology

Compared with other LLC resonant converter structures, the half-bridge LLC resonant converter has

the following advantages and disadvantages.

Advantages:

(1) The current flowing in the primary side of the transformer flows in during the entire period, which ensures the full use of the magnetic core and avoids magnetic bias.

(2) The voltage stress in the primary side of the transformer is low.

(3) The structure is simple and the component costs are relatively low.

Disadvantages:

(1) The current stress through the switches and primary side of the transformer is twice that of the full-bridge LLC resonant converter, and will cause large losses in the bridge capacitors.

(2) The current ripples in the secondary side of the transformer are large, which may lead to voltage spikes and oscillations.

(3) When the input voltage range is large, the switching frequency range needs to be increased accordingly. Thus, the potential high input will cause excessively high switching frequency and will intensify the adverse effects of the parasitic parameters, which may affect the converter system.

(4) In order to adapt to a wide range of input voltages, the magnetizing inductor is required to be small, which causes increasing resonant current, so that the conduction loss and hysteresis loss would increase, hence reducing the converter efficiency.

(5) With a wide input voltage range, if only selecting the power devices with high voltage tolerance, the conduction losses at the low-voltage state will also increase significantly, which will reduce the overall efficiency of the converter.

3.2 Full-bridge LLC resonant converter

As shown in Fig. 7, the full-bridge LLC resonant converter is composed of four switches, resonant components, two diodes, and an output capacitor. This converter is suitable for high and medium power transfers. This topology is widely used in EV charging stations, photovoltaic systems, battery chargers, welding systems, computer and communication power supplies, induction heating systems, and X-ray machine power supplies.

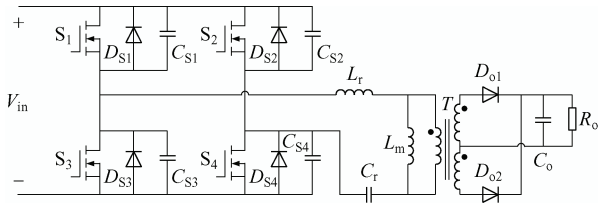

Fig. 7 The full-bridge LLC resonant converter topology

Compared with other LLC resonant converters, the full-bridge LLC resonant converter has the following advantages and disadvantages.

Advantages:

- (1) It has continuous input current and small current ripple, which can reduce the EMI pollution and improve the reliability of the converter.
- (2) The switches' voltage and current stresses are low, thus this type of converter is suitable for medium and high-power conditions.

Disadvantages:

- (1) The topology structure and peripheral circuits are complex, leading to complex design.
- (2) It requires four switching drivers, thus the cost of switch components is very significant.
- (3) The current ripple in the secondary side of the transformer is large, and there may be problems with voltage spikes and oscillations.

3.3 TL-LLC resonant converter

As shown in Fig. 8, the TL-LLC resonant converter is composed of four switches, resonant components, four diodes, and three capacitors. The TL-LLC resonant converter is always applied to high power conditions with a wide output range. This topology is widely used in EV charging stations.

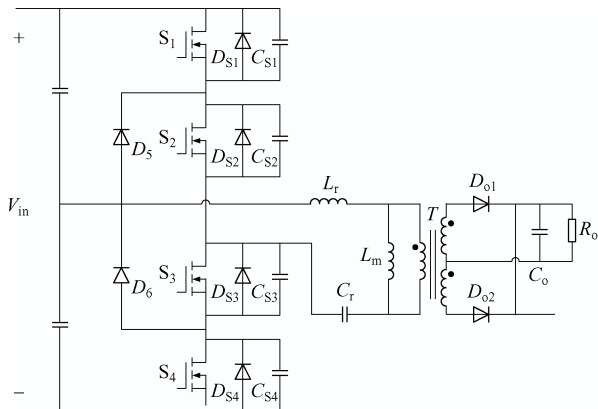

Fig. 8 The TL-LLC resonant converter topology

Compared with other LLC resonant converters, the TL-LLC resonant converter has the following

advantages and disadvantages.

Advantages:

- (1) The voltage stress on the switches is reduced to half of the input voltage, thus it is suitable for high power conditions and for use in narrowing the switching frequency range^[24].
- (2) Low harmonic in the output voltage.

Disadvantages:

- (1) There are four dead times to be designed, leading to complex preparatory work.
- (2) The TL-LLC resonant converter structure has 4 diodes and requires 4 switches, which also increases the complexity of the converter.
- (3) In order to achieve a stable output voltage with a low voltage input, a large voltage gain is required. However, the efficiency at a low voltage input is low, and the stress of the resonant elements is large, so it can only solve the problem of input fluctuation in a small range^[25].

4 LLC resonant converter uses in industry

As an advantageous topology with electrically isolated features, a soft-switching function, high energy density, and high-frequency operation potential, the LLC resonant converters are widely used in EV charging stations, LED lighting drivers, photovoltaic systems, LCD TV power supplies, and other practical products.

4.1 LLC resonant converter for LED light driver

Due to its small size, long lighting life, low energy losses, environmental-friendliness, high adjustability, and wide applicability, LED lighting has been recognized as the most promising lighting solution^[26-27]. However, LED drivers based on uncontrollable rectifier bridges have various defects, leading to energy losses, and EMI and harmonic pollution^[28]. Therefore, it is imperative to design an LED driver with wide adaptability, high stability, and low energy losses. As an extremely important part of the LED lighting equipment, the LED driver also needs to have a small size, high energy density, low economic cost, and high electromagnetic compatibility. Therefore, the LLC resonant converter is widely used in LED driving devices^[29].

Generally, in order to adapt to the household AC

power, a Boost power factor correction (PFC) converter is connected in front of the LLC resonant converter to form a two-stage structure aimed to improve the power factor and reduce the EMI and harmonic pollution^[30-31]. The widely used Boost structures include the traditional Boost PFC converter and interleaved parallel Boost PFC converter, as shown in Figs. 9-10. The second-stage LLC resonant converter is responsible for producing constant current and electrical isolation.

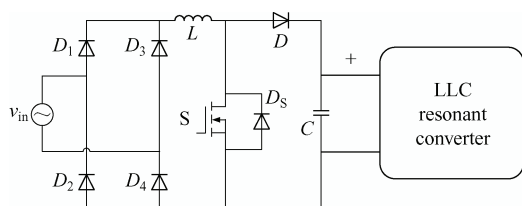

Fig. 9 LED driver of Boost PFC + LLC resonant converter

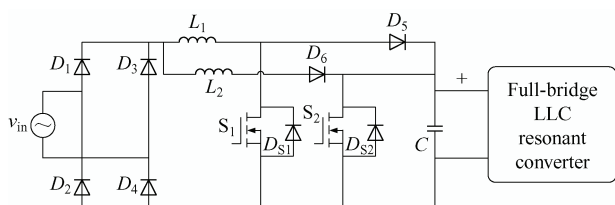

Fig. 10 LED driver of interleaved Boost PFC + LLC resonant converter

4.2 LLC resonant converter in LCD TV

LCD TVs have been developed because of their environmental-friendliness and excellent display effects^[32]. Due to the demand for thin and light LCD TVs, manufacturers have put forward high requirements for their built-in power supplies, including small size, small interference, and light weight, especially for the large-size (more than 101.6 cm) LCD TVs^[33]. Because of the high power, it is difficult to meet these requirements with traditional converter solutions such as flyback or forward converters. The high switching frequency enables the transformer in the LLC resonant converter to achieve small size, light weight, and electrical isolation, reducing harmonics and EMI pollution. Moreover, since the LLC resonant converters can perform soft switching, they can achieve high efficiency. Therefore, power supply systems based on the LLC resonant converter are widely used in LCD TV power supplies^[34-35].

In order to adapt to commercial power, an AC-DC converter is usually added in front of the LLC

resonant converter to achieve power factor correction, realize a wide range of input, and increase the voltage level to 400 V^[33]. As shown in Fig. 11, the structure of a first-stage Boost PFC converter and second-stage half-bridge LLC resonant converter is the most popular topology, in which the LLC resonant converter is responsible for reducing the voltage to 24 V, 12 V or 5.5 V, respectively, and achieving safe electrical isolation.

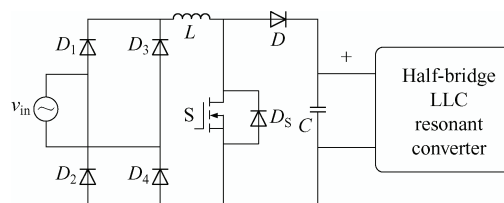

Fig. 11 LCD TV power supply of Boost PFC + half-bridge LLC resonant converter

4.3 LLC resonant converter in an EV charging station

Thanks to their low environmental contamination and clean energy consumption, electric vehicles are becoming the future of the transportation system^[36]. However, the development of EV charging piles is constrained by the charging technology, including sufficient driving mileage, high-power and fast charging, and convenient charging devices^[37-38]. When designing EV chargers, because of the charging devices' high power level and high switching frequency, energy losses in the EV chargers cannot be overlooked. Additionally, considering the construction cost of the integrated power stations, the converter devices cost cannot be excessive and the EV charging stations volume must be as small as possible^[39]. Thus, the charging converter needs to have high efficiency, high energy density, light weight, high reliability, and excellent shock resistance^[40]. Therefore, with their soft-switching function, high magnetic integration, wide output range, and high efficiency, the LLC resonant converters play a significant role in the electric vehicle chargers^[41-42].

In order to adapt to the working conditions of a wide-range input and output, a Boost PFC + LLC two-stage topology is usually applied to the on-board controller (OBC)^[43]. The Boost-stage boosts the wide-range input voltage of 200-400V to the bus voltage of 410 V, improving the power factor and

eliminating the EMI pollution, while the LLC resonant stage is responsible for wide-output range, high efficiency, and electrical isolation. Moreover, the Bidirectional (Bi) OBC has gained attention with its forward mode charging and reverse mode outputting AC voltage to the power grid.

(1) OBC of Boost PFC + full-bridge LLC resonant converter.

As shown in Fig. 12, the single-phase Boost converter has a simple structure and low hardware cost, and is suitable for high voltage, but the current stress and current ripple are large with a huge filter volume.

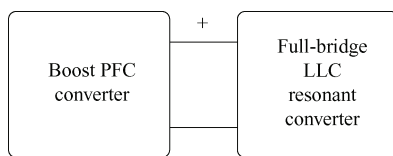

Fig. 12 OBC of Boost PFC + full-bridge LLC resonant converter

(2) OBC of bridgeless PFC + full-bridge LLC resonant converter.

As shown in Fig. 13, the bridgeless converter has a high efficiency advantage, because it does not have a

rectifier bridge, but the power factor is difficult to improve and the current ripple is large. This topology is suitable for wide input range. However, the common mode EMI of the bridgeless PFC converter is large, and in order to achieve accurate control, it is necessary to use expensive Hall sensors. Thus, some scholars and engineers suggest using the differential sampling method to reduce the manufacturing cost.

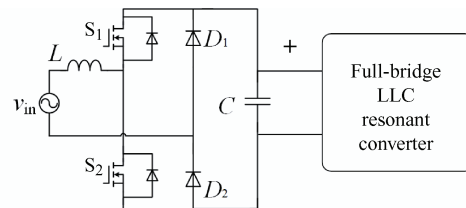

Fig. 13 OBC of bridgeless Boost PFC + full-bridge LLC resonant converter

(3) OBC of bridgeless Boost PFC + LLC resonant converter with double transformers.

As shown in Fig. 14, double transformers are able to reduce the transformer's high and improve the energy density. Besides, it is easy to regulate it in practice. However, the double transformers also increase OBC's volume and weight.

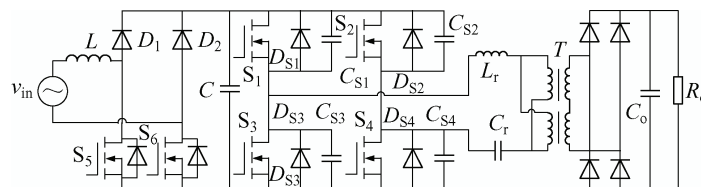

Fig. 14 OBC of bridgeless Boost PFC + full-bridge LLC resonant converter with double transformers

(4) OBC of interleaved parallel Boost PFC + full-bridge LLC resonant converter.

As shown in Fig. 15, the first-stage interleaved parallel Boost PFC converter has the following advantages: ① it has a high energy density and small current ripple; ② it can reduce the current switches stress, which is responsible for stabilizing the output voltage from the wide-range input; ③ it can significantly reduce the inductor and capacitor values in the converter; ④ the input current is shared by two channels, which is more conducive to a small radiator design and it improves the converter reliability. However, it still suffers from the large equivalent series resistance, leading to unnecessary energy loss.

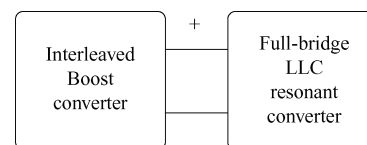

Fig. 15 OBC of interleaved parallel Boost PFC converter and full-bridge LLC resonant converter

(5) Bi-OBC of Bi-LLC resonant converter.

As shown in Fig. 16, the Bi-LLC resonant converter can achieve a wide range of bidirectional output and high bidirectional efficiency, and it replaces two converters, thus reducing the converter volume and further improving the energy density^[44]. However, it is complicated to appropriately tune or design the parameters. When working in full-power or low-output condition, a large reactive power flows in the resonant

network, and the resonant and switch-off currents are both large. Besides, the increase in the number of

magnetic components leads to a decrease in energy density and an increase in energy losses.

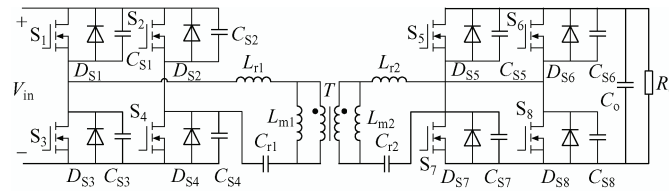

Fig. 16 OBC of Bi-LLC resonant converter

4.4 LLC resonant converter in photovoltaic systems

Given the energy crisis, photovoltaic power generation has been widely used and industrialized, due to its environmental-friendliness^[45]. As an essential part of the photovoltaic system, the photovoltaic grid-connected inverter is the key to improving the efficiency and reliability of the whole photovoltaic power generation system, extend its lifespan and reduce economic costs^[46-47]. However, due to the parasitic capacitor between the photovoltaic panel and the ground, current leakage will occur, which not only poses a threat to human safety, but also damages the electronics components. Therefore, the electrical isolation of the photovoltaic systems is necessary^[48]. Since the LLC resonant converter can realize the soft-switching of power devices, electrical isolation and magnetic integration, it can greatly reduce the switching losses of power devices, significantly improving efficiency, expanding the devices' life cycle, and improving the power quality and safety^[49].

The photovoltaic inverter includes three parts: the DC-DC Boost PFC stage, the DC-DC LLC resonant stage, and the DC-AC inverter stage.

(1) Photovoltaic inverter system of Boost PFC + full-bridge LLC resonant converter + full-bridge inverter.

The structure of a typical LLC photovoltaic grid-connected inverter is shown in Fig. 17. The DC-DC Boost converter is responsible for boosting the wide-range input from the solar cell array and realizing the maximum power point tracking (MPPT)^[50]. The LLC resonant converter is responsible for the high frequency operation and electrical isolation. The inverter is connected to the power grid and provides the power to the load.

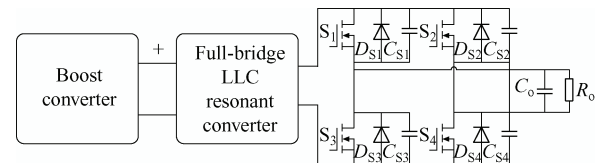

Fig. 17 Photovoltaic inverter system of Boost PFC + full-bridge LLC resonant converter + full-bridge inverter

(2) Photovoltaic system of interleaved parallel Boost PFC + full-bridge LLC resonant converter + full-bridge inverter.

As shown in Fig. 18, the interleaved Boost converter is able to raise the wide-range output voltage from the photovoltaic array to the rated bus voltage, track the maximum power point, and reduce the filter size.

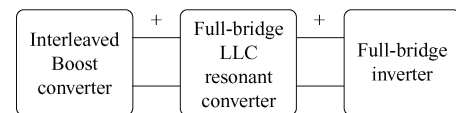

Fig. 18 Photovoltaic system of interleaved parallel Boost PFC + full-bridge LLC resonant converter

(3) Photovoltaic system of Boost converter + Bi-LLC resonant converter + full-bridge inverter.

As shown in Fig. 19, the bidirectional LLC resonant converter has the capability of a bidirectional power flow, regulating power, achieving electrical isolation, recovering energy, and maintaining the stability of the photovoltaic system. Besides, the inverter plays the role of peak cut, feeding excess energy to the load or power grid.

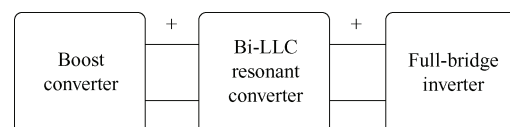

Fig. 19 Photovoltaic system of Boost converter + Bi-LLC resonant converter + full-bridge inverter

4.5 LLC resonant converter in other industrial applications

(1) Since an LLC resonant converter can achieve wide output and input ranges, it is suitable for power supply in gas shielded welding, wireless heating, X-ray machine, and battery charger.

(2) Due to the light-weight characteristics of the LLC resonant converter, it is also suitable for power conversion in aviation, communication and computers.

(3) The LLC resonant converter is capable of electrical isolation and eliminating the EMI pollution, so it is also suitable as a DC-DC converter in a microgrid system and microwave.

5 The future evolution of the LLC resonant converter

Although the research on the LLC resonant converter has been very extensive, there are still a lot of open topics for research in this area.

(1) The applications of SiC and GaN devices.

Silicon-based devices require multiple components to be connected in parallel or in a series to ensure the stability and reliability of converters, resulting in increased device costs and increased switching losses.

SiC-based devices with better voltage withstanding characteristics, wide band gap, high drift saturation speed, high thermal conductivity, and high critical breakdown electric field can be used for better performances^[51-52]. Thus, silicon-based devices can be replaced by SiC-based devices to reduce the number of devices and further improve the efficiency and stability of the converters^[53]. Besides, SiC devices are conducive to the further evolution of the power electronic converters towards light weight, small size, and modularization, laying a solid foundation for a technological breakthrough in photovoltaic inverters and energy storage converters in distributed power and microgrid applications^[54].

The GaN device has a small on-voltage threshold range, fast switching, no reverse recovery loss, low on-resistance, and good high-frequency characteristics, and is able to switch voltage of hundreds of volts in a few nanoseconds^[55-57], which can replace silicon-based equipment even in high-frequency conditions of over 1 million Hz.

(2) The balance between radiator and transformer.

Due to the high switching frequency, high-frequency transformers can be applied to the LLC resonant converter, reducing the size of the transformer. However, the increase in the switching frequency will result in increased switching losses and larger radiator devices, which would lead to an increase in the size of the radiation system^[58]. Therefore, it is necessary to seek an appropriate trade-off between the transformer volume and the radiator volume to further optimize the energy density of the converter system.

(3) Magnetic integration technology.

A large number of magnetic components will cause reduced energy density and increased losses, especially in Bi-LLC resonant converters. Therefore, it is important to use magnetic integration technology to combine multiple discrete magnetic components into an integrated magnetic component, and reduce the volume and weight of the converter to reduce energy losses and output ripples, and to improve the overall performance of the converter.

(4) Trade-off between switching and circulating conduction losses.

When the converter works at the resonant point, the efficiency is the highest, and the circulating current is small. However, when the switching frequency is changed, and the operating point moves from the resonant point to the sub-resonant region, the switching loss decreases and the circulating current increases, which causes increased conduction loss. When the operating point moves to the super-resonant region, the circulating current decreases, but the secondary fails to realize ZCS, which causes increased switching losses. Therefore, it needs to be carefully evaluated in a small operating region with a narrow gain range and high efficiency. Loss distribution near the resonant point should also be considered in order to optimize the system design.

6 Conclusions

In this paper, the history of the LLC resonant converter is reviewed. Then, the advantages of the LLC resonant converters and details of the three most common LLC resonant converter topologies are specifically analyzed, including the half-bridge LLC resonant converter, the full-bridge LLC resonant

converter, and the TL-LLC resonant converter, with their respective advantages and disadvantages in industrial applications. Moreover, the LLC resonant converter applications in various industries are reviewed, mainly including LCD TV power supply, LED driver, photovoltaic system, and OBC. Finally, the future evolution of the LLC resonant converter technology is discussed and predicted.

References

- [1] R Liu, C Q Lee. Analysis and design of LLC-type series resonant convertor. *Electronics Letters*, 2018, 24(24): 1517-1519.
- [2] C Fei, Q Li, F C Lee. Digital implementation of adaptive synchronous rectifier (SR) driving scheme for high-frequency LLC converters with microcontroller. *IEEE Transactions on Power Electronics*, 2018, 33(6): 5351-5361.
- [3] G Zhang, Z Li, B Zhang, et al. Power electronics converters: Past, present and future. *Renewable and Sustainable Energy Reviews*, 2018, 81(2): 2028-2044.
- [4] M A Saket, N Shafiei, M Ordonez. LLC converters with planar transformers: Issues and mitigation. *IEEE Transactions on Power Electronics*, 2017, 32(6): 4524-4542.
- [5] H Park, M Kim, J Jung. Spread spectrum technique to reduce EMI emission for an LLC resonant converter using a hybrid modulation method. *IEEE Transactions on Power Electronics*, 2018, 33(5): 3717-3721.
- [6] M Mohammadi, M Ordonez. Synchronous rectification of LLC resonant converters using homopolarity cycle modulation. *IEEE Transactions on Industrial Electronics*, 2019, 66(3): 1781-1790.
- [7] L Hong, H Ma, J Wang, et al. An efficient algorithm strategy for synchronous rectification used in LLC resonant converters. *IECON 2016-42nd Annual Conference of the IEEE Industrial Electronics Society*, Florence, 2016: 2452-2456.
- [8] K N Mude, K Aditya. Comprehensive review and analysis of two-element resonant compensation topologies for wireless inductive power transfer systems. *Chinese Journal of Electrical Engineering*, 2019, 5(2): 14-31.
- [9] J Liu, J Zhang, T Q Zheng, et al. A modified gain model and the corresponding design method for an LLC resonant converter. *IEEE Transactions on Power Electronics*, 2017, 32(9): 6716-6727.
- [10] E S Glitz, J Hsu, M Ordonez. Power loss estimation in LLC synchronous rectification using rectifier current equations. *IEEE Transactions on Industrial Electronics*, 2020, 67(5): 3696-3704.
- [11] H Wang, S Dusmez, A Khaligh. Design and analysis of a full-bridge LLC-based PEV charger optimized for wide battery voltage range. *IEEE Transactions on Vehicular Technology*, 2014, 63(4): 1603-1613.
- [12] L A D Ta, N D Dao, D Lee. High-efficiency hybrid LLC resonant converter for on-board chargers of plug-in electric vehicles. *IEEE Transactions on Power Electronics*, 2020, 35(8): 8324-8334.
- [13] G Zhang, J Zeng, S S Yu, et al. Control design and performance analysis of a double-switched LLC resonant rectifier for unity power factor and soft-switching. *IEEE Access*, 2020, 8: 44511-44521.
- [14] E S Glitz, M Ordonez. MOSFET power loss estimation in LLC resonant converters: Time interval analysis. *IEEE Transactions on Power Electronics*, 2019, 34(12): 11964-11980.
- [15] Z Li, T Wu, G Zhan, et al. Hybrid modulation method combining variable frequency and double phase-shift for a 10 kW LLC resonant converter. *IET Power Electronics*, 2018, 11(13): 2161-2169.
- [16] J Baek, J Kim, B Cho. Low-profile AC/DC converter for laptop adaptor. *2011 Twenty-Sixth Annual IEEE Applied Power Electronics Conference and Exposition (APEC)*, 2011, Fort Worth, TX, 2011: 60-64.
- [17] İ Demirel, B Erkmen. A very low-profile dual output LLC resonant converter for LCD/LED TV applications. *IEEE Transactions on Power Electronics*, 2014, 29(7): 3514-3524.
- [18] M F Menke, Á R Seidel, R V Tambara. LLC LED driver small-signal modelling and digital control design for active ripple compensation. *IEEE Transactions on Industrial Electronics*, 2019, 66(1): 387-396.
- [19] G Li, J Xia, K Wang, et al. Hybrid modulation of parallel-series LLC resonant converter and phase shift full-bridge converter for a dual-output DC-DC converter. *IEEE Journal of Emerging and Selected Topics in Power Electronics*, 2019, 7(2): 833-842.
- [20] S M Tayebi, H Hu, S Abdel-Rahman, et al. Dual-input single-resonant tank LLC converter with phase shift control for PV applications. *IEEE Transactions on Industry Applications*, 2019, 55(2): 1729-1739.
- [21] X Fang, H Hu, Z J Shen, et al. Operation mode analysis and peak gain approximation of the LLC resonant converter. *IEEE Transactions on Power Electronics*, 2012, 27(4): 1985-1995.
- [22] U Kundu, K Yenduri, P Sensarma. Accurate ZVS analysis for magnetic design and efficiency improvement of full-bridge LLC resonant converter. *IEEE Transactions on*

- Power Electronics*, 2017, 32(3): 1703-1706.
- [23] A Hariya, T Koga, K Matsuura, et al. Circuit design techniques for reducing the effects of magnetic flux on GaN-HEMTs in 5-MHz 100-W high power-density LLC resonant DC-DC converters. *IEEE Transactions on Power Electronics*, 2017, 32(8): 5953-5963.
- [24] Z Guo, D Sha, X Liao. Hybrid phase-shift-controlled three-level and LLC DC-DC converter with active connection at the secondary side. *IEEE Transactions on Power Electronics*, 2015, 30(6): 2985-2996.
- [25] K Jin, X Ruan. Hybrid full-bridge three-level LLC resonant converter-a novel DC-DC converter suitable for fuel-cell power system. *IEEE Transactions on Industrial Electronics*, 2006, 53(5): 1492-1503.
- [26] Y Wang, N Qi, Y Guan, et al. A single-stage LED driver based on SEPIC and LLC circuits. *IEEE Transactions on Industrial Electronics*, 2017, 64(7): 5766-5776.
- [27] J Kim, J Moon, G Moon. Duty-ratio-control-aided LLC converter for current balancing of two-channel LED driver. *IEEE Transactions on Industrial Electronics*, 2017, 64(2): 1178-1184.
- [28] B Singh, B N Singh, A Chandra, et al. A review of single-phase improved power quality AC-DC converters. *IEEE Transactions on Industrial Electronics*, 2003, 50(5): 962-981.
- [29] J Ma, X Wei, L Hu, et al. LED driver based on boost circuit and LLC converter. *IEEE Access*, 2018, 6: 49588-49600.
- [30] Y Wang, Y Guan, K Ren, et al. A single-stage LED driver based on BCM boost circuit and LLC converter for street lighting system. *IEEE Transactions on Industrial Electronics*, 2015, 62(9): 5446-5457.
- [31] H Ma, Y Li, Q Chen, et al. A single-stage integrated boost-LLC AC-DC converter with quasi-constant bus voltage for multichannel LED street-lighting applications. *IEEE Journal of Emerging and Selected Topics in Power Electronics*, 2018, 6(3): 1143-1153.
- [32] H Chiu, Y Lo, T Lee, et al. Design of an RGB LED backlight circuit for liquid crystal display panels. *IEEE Transactions on Industrial Electronics*, 2009, 56(7): 2793-2795.
- [33] W H Liao, Y Liu, S C Wang. Design and implementation of a digitalized power supply for large scale LCD TV. *2010 8th IEEE International Conference on Industrial Informatics*, Osaka, 2010: 786-791.
- [34] B R Lin, S F Wu. Analysis of a resonant converter with two transformers and voltage doubler rectifier. *IET Power Electronics*, 2011, 4(4): 400-406.
- [35] Z Zhao, Q Xu, Y Dai, et al. Minimum resonant capacitor design of high-power LLC resonant converter for comprehensive efficiency improvement in battery charging application. *IET Power Electronics*, 2018, 11(11): 1866-1874.
- [36] Z Fang, T Cai, S Duan, et al. Optimal design methodology for LLC resonant converter in battery charging applications based on time-weighted average efficiency. *IEEE Transactions on Power Electronics*, 2015, 30(10): 5469-5483.
- [37] F Musavi, M Craciun, D S Gautam, et al. Control strategies for wide output voltage range LLC resonant DC-DC converters in battery chargers. *IEEE Transactions on Vehicular Technology*, 2014, 63(3): 1117-1125.
- [38] V R K Kanamarlapudi, B Wang, N K Kandasamy, et al. A new ZVS full-bridge DC-DC converter for battery charging with reduced losses over full-load range. *IEEE Transactions on Industry Applications*, 2018, 54(1): 571-579.
- [39] V R K Kanamarlapudi, B Wang, P L So, et al. Analysis, design, and implementation of an APWM ZVZCS full-bridge DC-DC converter for battery charging in electric vehicles. *IEEE Transactions on Power Electronics*, 2017, 32(8): 6145-6160.
- [40] S Rivera, B Wu, S Kouro, et al. Electric vehicle charging station using a neutral point clamped converter with bipolar DC bus. *IEEE Transactions on Industrial Electronics*, 2015, 62(4): 1999-2009.
- [41] E S Glitz, J Hsu, M Ordonez. Power loss estimation in LLC synchronous rectification using rectifier current equations. *IEEE Transactions on Industrial Electronics*, 2020, 67(5): 3696-3704.
- [42] E S Glitz, M Ordonez. MOSFET power loss estimation in LLC resonant converters: Time interval analysis. *IEEE Transactions on Power Electronics*, 2019, 34(12): 11964-11980.
- [43] R Pandey, B Singh. A power-factor-corrected LLC resonant converter for electric vehicle charger using Cuk converter. *IEEE Transactions on Industry Applications*, 2019, 55(6): 6278-6286.
- [44] Y Shen, W Zhao, Z Chen, et al. Full-bridge LLC resonant converter with series-parallel connected transformers for electric vehicle on-board charger. *IEEE Access*, 2018, 6: 13490-13500.
- [45] J Liu, Z Zheng, K Wang, et al. Comparison of boost and LLC converter and active clamp isolated full-bridge boost converter for photovoltaic DC system. *The Journal of Engineering*, 2019, 2019(16): 3007-3011.
- [46] X Guo, M C Cavalcanti, A M Farias, et al. Single-carrier modulation for neutral-point-clamped inverters in

- three-phase transformerless photovoltaic systems. *IEEE Transactions on Power Electronics*, 2013, 28(6): 2635-2637.
- [47] X Guo. A novel CH5 inverter for single-phase transformerless photovoltaic system applications. *IEEE Transactions on Circuits and Systems II: Express Briefs*, 2017, 64(10): 1197-1201.
- [48] M Shang, H Wang, Q Cao. Reconfigurable LLC topology with squeezed frequency span for high-voltage bus-based photovoltaic systems. *IEEE Transactions on Power Electronics*, 2018, 33(5): 3688-3692.
- [49] C Chang, E Chang, H Cheng. A high-efficiency solar array simulator implemented by an LLC resonant DC-DC converter. *IEEE Transactions on Power Electronics*, 2013, 28(6): 3039-3046.
- [50] D Vinnikov, A Chub, E Liivik, et al. High-performance quasi-Z-source series resonant DC-DC converter for photovoltaic module-level power electronics applications. *IEEE Transactions on Power Electronics*, 2017, 32(5): 3634-3650.
- [51] X Ren, Z Xu, Z Zhang, et al. A 1-kV input SiC LLC converter with split resonant tanks and matrix transformers. *IEEE Transactions on Power Electronics*, 2019, 34(11): 10446-10457.
- [52] H A Moghadam, S Dimitrijević, J Han, et al. Transient-current method for measurement of active near-interface oxide traps in 4H-SiC MOS capacitors and MOSFETs. *IEEE Transactions on Electron Devices*, 2015, 62(8): 2670-2674.
- [53] C Shi, H Wang, S Dusmez, et al. A SiC-based high-efficiency isolated on board PEV charger with ultrawide DC-link voltage range. *IEEE Transactions on Industry Applications*, 2017, 53(1): 501-511.
- [54] W Qian, J Lu, H Bai, et al. Hard-switching 650-V GaN HEMTs in an 800-V DC-grid system with no-diode-clamping active-balancing three-level topology. *IEEE Journal of Emerging and Selected Topics in Power Electronics*, 2019, 7(2): 1060-1070.
- [55] L Xiao, L Wu, J Zhao, et al. Virtual prototype and GaN HEMT based high frequency LLC converter design. *The Journal of Engineering*, 2019(7): 4672-4674.
- [56] M Mu, F C Lee. Design and optimization of a 380-12 V high-frequency, high-current LLC converter with GaN devices and planar matrix transformers. *IEEE Journal of Emerging and Selected Topics in Power Electronics*, 2016, 4(3): 854-862.
- [57] H Wen, J Gong, X Zhao, et al. Analysis of diode reverse recovery effect on ZVS condition for GaN-based LLC resonant converter. *IEEE Transactions on Power Electronics*, 2019, 34(12): 11952-11963.
- [58] M Andresen, J Kuprat, V Raveendran, et al. Active thermal control for delaying maintenance of power electronics converters. *Chinese Journal of Electrical Engineering*, 2018, 4(3): 13-20.



Junming Zeng was born in Yangjiang, Guangdong, China, in 1997. He received a bachelor degree from the Guangdong University of Technology in Guangzhou in 2020, and he is currently working towards a master degree in power engineering from the School of Electrical & Electronic Engineering, Nanyang Technological University, Singapore.

His current research interests include power electronics topology and their applications.

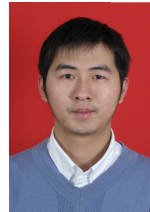

Guidong Zhang (M'13) was born in Guangdong, China, in 1986. He received a B.S. degree and two Ph.D. degrees from Xi'an University of Technology, South China University of Technology and FernUniversität in Hagen in 2008, 2014, and 2015, respectively.

He is currently an associate professor with the School of Automation, Guangdong University of Technology, Guangzhou. His research interests include power electronics topology and their applications.



Samson Shenglong Yu (S'15-M'17) completed a master's degree in electrical and electronic engineering with distinction, and a Ph.D. degree in electrical power engineering from the University of Western Australia (UWA), Perth, Western Australia, Australia, in 2014 and 2017, respectively. From 2017 to 2019, he served as a postdoctoral research fellow at UWA. He is

currently an assistant professor at Deakin University, Melbourne, Victoria, Australia. His research interests include power system analysis, renewable energy integration and forecasting, power electronics and their applications and control.

Dr. Yu received the first and second Best Paper Awards in the IEEE Australia Paper Competition in 2016 and 2017, the Best Reviewer Award for IEEE Transactions on Smart Grid in 2018, and published a featured article in *Chaos: An interdisciplinary journal of Nonlinear Science* in 2019.



Bo Zhang (M'03-SM'15) was born in Shanghai, China, in 1962. He received a B.S. degree in electrical engineering from Zhejiang University, Hangzhou, China, in 1982, an M.S. degree in power electronics from Southwest Jiaotong University, Chengdu, China, in 1988, and a Ph.D. degree in power electronics from Nanjing University of Aeronautics and Astronautics, Nanjing, China, in 1994.

His current research interests include nonlinear analysis and control of power supplies and AC drives.



Yun Zhang received B.S. and M.S. degrees in automatic engineering from Hunan University, Changsha, China, in 1982 and 1986, respectively, and a Ph.D. degree in automatic engineering from the South China University of Technology, Guangzhou, China, in 1998.

He is currently a professor with the School of Automation, Guangdong University of Technology, Guangzhou. His current research interests include intelligent control systems, network systems, and signal processing.