

Magnets for a Muon Collider – Needs and Plans

L. Bottura, C. Accettura, N. Amemiya, B. Auchmann, J.S. Berg, A. Bersani, A. Bertarelli, F. Boattini, B. Bordini, P. Borges de Souza, M. Breschi, B. Caiffi, X. Chaud, F. Debray, A. Dudarev, M. Eisterer, S. Fabbri, S. Farinon, P. Ferracin, H. De Gersem, A. Kario, A. Kolehmainen, J. Kosse, J. Lorenzo Gomez, R. Losito, S. Mariotto, M. Mentink, T. Mulder, R. Musenich, D. Novelli, T. Ogitsu, M. Palmer, J. Pavan, H. Piekarz, A. Portone, L. Quettier, E. Rochepault, L. Rossi, T. Salmi, H. Schneider-Muntau, C. Senatore, M. Statera, H.H.J. Ten Kate, P. Testoni, G. Vallone, A. Verweij, R. Van Weelderden, M. Wozniak, A. Yamamoto, Y. Yang, Y. Zhai, A. Zlobin, and the Muon Magnets Working Group

Abstract—We describe the magnet challenges for a Muon Collider, an exciting option considered for the future of particle physics at the energy frontier. Starting from the comprehensive work performed by the US Muon Accelerator Program, we have reviewed the performance specifications dictated by beam physics and the operating conditions to satisfy the accelerator needs. Among the many magnets that make up a muon collider, we have identified four systems that represent well the envelope of challenges: the target and capture solenoid, the final cooling solenoid, the accelerator dipoles and the collider dipoles. These systems provide focus for the development of novel concepts, largely based on HTS for reasons of performance, cost and sustainability. After giving a consolidated overview of the needs for the magnet systems, we describe here the basic technology options considered, and the plan for design and development activities.

Index Terms — Muon Collider, Accelerator Magnets, High Temperature Superconductors

I. INTRODUCTION

THE Muon Collider (MuC) has been identified as one of the options with great potential for the next step in particle physics at the energy frontier [1]. Muons are point-like particles [2-4] and can be accelerated to very high energies in circular machines since they do not suffer from the limitation due to synchrotron radiation experienced by electrons. Studies also show that a MuC with center-of-mass energy of about 1 TeV and higher can provide the most compact and power efficient route towards a high luminosity lepton collider [5,6]. The main challenge arises from the short muon lifetime at rest (2.2 μ s) and the difficulty of producing bunched beams of muons with small emittance. These challenges are being addressed within the scope of activities of the International Muon Collider Collaboration (IMCC) [7], initiated under the auspices of the Laboratory Directors Group (LDG) in response to the recommendation from the European

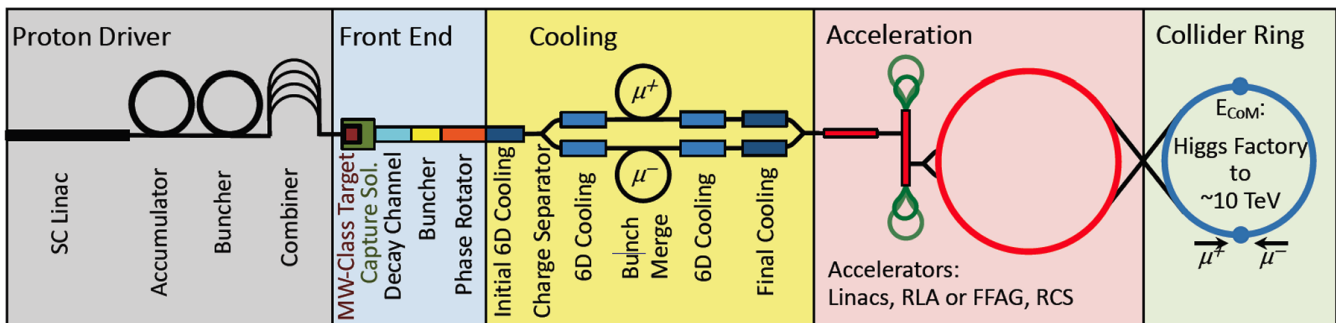

Fig. 1. Layout of the Muon Collider as produced by the US Muon Accelerator Program [12], taken as the initial baseline for our study and as an explanation of the characteristics and functions of the various stages of the accelerator complex.

Submitted for review September 19, 2023

L. Bottura, C. Accettura, A. Bertarelli, F. Boattini, B. Bordini, P. Borges de Souza, A. Dudarev, S. Fabbri, A. Kolehmainen, R. Losito, M. Mentink, T. Mulder, A. Verweij, R. Van Weelderden, M. Wozniak are with CERN, Geneva, Switzerland. N. Amemiya is with Kyoto University, Kyoto, Japan. B. Auchmann, J. Kosse are with PSI, Villigen, Switzerland. J.S. Berg, M. Palmer are with BNL, Upton, NY, USA. A. Bersani, B. Caiffi, S. Farinon, S. Mariotto, R. Musenich, D. Novelli, J. Pavan, L. Rossi, M. Statera, are with INFN Genova and Milano, Italy. M. Breschi is with University of Bologna, Italy. X. Chaud, F. Debray are with LNCMI, Grenoble, France. M. Eisterer is with ATI, Vienna, Austria. P. Ferracin, G. Vallone are with LBNL, Berkeley, CA, USA.

H. De Gersem is with TU Darmstadt, Germany. A. Kario, H.H.J. Ten Kate are with University of Twente, The Netherlands. J. Lorenzo Gomez, A. Portone, P. Testoni are with F4E, Barcelona, Spain. T. Ogitsu, A. Yamamoto are with KEK, Tsukuba, Japan. H. Piekarz, A. Zlobin are with FNAL, Batavia, IL, USA. L. Quettier, E. Rochepault are with CEA, Saclay, France. T. Salmi is with Technical University of Tampere, Finland. H. Schneider-Muntau is with CS&T, France. C. Senatore is with University of Geneva, Switzerland. Y. Yang is with University of Southampton, UK. Y. Zhai is with PPPL, Plainsboro, NJ, USA.

Corresponding author: Luca Bottura (luca.bottura@cern.ch)

This work is supported by the EU under Grant Agreement 101094300.

1OrM1-1

Strategy Group [8,9]. Since beginning 2023 the work is also supported by the EU through the design study MuCol [10]. The main objective for the next five years is to evolve from previous ideas and concepts [11,12] towards a consistent MuC concept in the range of 10 TeV center-of-mass energy, and document the results in a pre-conceptual design report submitted for evaluation during the next European Strategy exercise (planned for 2026).

Normal- and super-conducting magnets have been identified as a crucial technology for a MuC [13]. The following paper provides a summary of the magnet demands, technology options, and concepts selected for the study so far, providing finally a first overview of the performance targets that will drive magnet R&D for a MuC.

II. MAGNET NEEDS AND CHALLENGES

The most complete configuration of a MuC was produced by the US Muon Accelerator Program (MAP) [11, 12]. This study provides conceptual solutions for the main systems in the MuC complex, including an overview of the magnet requirements. The concept developed by MAP is shown in Fig. 1 [12]. We have taken MAP as the starting point to identify the main challenges and technology options, and rank priorities. The following sections recall the main functions of each block of the MuC concept, and the corresponding demands in terms of magnet performance. We note already here that the magnets in the whole accelerator complex functions in steady state, apart from the fast ramped magnets in the rapid cycling synchrotrons.

A. Front End (muon production and capture)

Muons are produced by the decay of the pions generated by the collision of a proton pulse with a target. The target, with outer dimension in the range of 150 to 250 mm, depending on technology, is inserted in a steady-state, high field “target solenoid”, whose function is to capture the pions and guide them into a “decay and capture channel”, also embedded in solenoid magnets. To maximize capture efficiency, the magnetic field profile along the axis of the channel needs to have a specific shape, with peak field of 20 T on the target, and an adiabatic decay to approximately 2 T at the exit of the channel, over a total length of approximately 18 m [14].

Besides the high field values, another challenge derives from the radiation environment due to the interaction of the multi-MW proton beam with the target. To avoid heating and radiation damage, the target, decay and capture solenoids need a radiation shield, consisting of a combination of a heavy metal like tungsten (to intercept photons from the synchrotron radiation generated by the decay electrons [22]) and a moderator like water (to reduce the fluence of secondary neutrons). The shield thickness defines the magnet bore, and depends on the acceptable nuclear heat and radiation damage on the solenoid coils. Nuclear calculations show that with a shield of approximately 500 mm thickness the radiation heat in the coils would be in the range of 5 kW, local radiation dose in

the range of 80 MGy and a peak DPA in the range of 10^{-2} . A large bore dimension implies high stored magnetic energy, which in turn affects electromagnetic forces, magnet protection, and cost as we will discuss later.

B. Cooling

The beam of muons exiting the target, decay and capture channel has a very large physical dimension (in the range of few tens of cm) and energy spread (as much as 25 % around the nominal beam momentum of about 200 MeV/c). The beam needs to be compacted both in space and momentum to reach phase space dimensions suitable for a collider. This “beam cooling” process is mainly done by a long sequence of energy loss steps in an absorber of low atomic weight (e.g. liquid H₂ or LiH), followed by acceleration in RF cavities. To contain and guide the beam, the absorbers and the RF cavities are placed in the bore of solenoids of broadly increasing field. This provides a cooling effect in the six dimensions (6D) of the beam phase space (position and momentum). The final emittance of the muon beam, the measure of beam size in phase space, is inversely proportional to the strength of the final cooling solenoids. A design study from MAP based on a 30 T final cooling solenoid demonstrated reduction of emittance from an initial value of 45 mm radians (at the exit of the front end) to final value of about 55 μ m radians roughly a factor of two greater than the transverse emittance goal (25 μ m radians), can be achieved [15,16]. However, other analyses [17] show that fields in the range of 50 T improve the final emittance requirements and offer further gains in beam brightness. We have taken the US-MAP results as baseline of our work on the 6D cooling solenoids, paying particular attention on the improvement of the final cooling with solenoids producing fields higher than 30 T.

C. Acceleration

Muons need to be accelerated rapidly to extend their lifetime in the laboratory frame. The acceleration consists of a linear accelerator followed by a sequence of a Rapid-Cycled Synchrotron (RCS) and Hybrid Cycled Synchrotrons (HCS) [18, 19]. The RCS is based on normal conducting (NC) fast ramped magnets, swinging from an injection to an extraction field level. In a HCS, static superconducting (SC) magnets provide a field offset, and NC fast-ramping magnets are powered from peak negative to peak positive field, thus making use of a full field swing. This produces an accelerator of smaller dimension than an equivalent RCS. In the present baseline, the NC dipoles in the first RCS need to sweep from 0.36 to 1.8 T within 0.35 ms (i.e. a rate of 4 kT/s). In the last HCS the NC dipoles swing from -1.8 T to 1.8 T, in 6.37 ms (i.e. a rate of about 560 T/s).

Design concepts of NC fast ramped magnets were developed by US-MAP, for peak operating field of 1.5 T [20]. SC dipoles for HCS were not yet studied in detail, besides setting target

1OrM1-1

values for bore field and magnet length. Beyond magnet engineering, the primary challenge of an accelerator ring of the required dimension is that the stored energy is of the order of several tens of MJ. Powering at a high-pulse rate with good energy recovery efficiency between pulses will require mastery in the management of peak power in the range of tens of GW. Resonant circuits combined with energy storage systems seem to be the only viable solution. A high energy storage density and high quality factor are mandatory to limit foot-print, energy consumption, capital and operating cost.

D. Collider

The last stage of the muon accelerator complex is the collider ring, where two counter-rotating positive and negative muon beam bunches collide. The collider ring needs to have the smallest possible circumference to collide the stored muon beams as often as practically feasible and thus make the best use of their limited life-time [21]. At the same time, sufficient radiation shielding must be present to protect against the sizeable radiation and heat loads from muon decay and collisions. A heat load of 500 W/m originated by muon decay (electrons) and synchrotron radiation is reduced by shielding to below 5 W/m at the level of the coil, and radiation dose below 40 MGy [22]. To allow for a compact collider ring and maintain sufficient space for shielding, the arc and Interaction Region (IR) dipole and quadrupole magnets thus need to be high-field and large aperture [23, 24].

The assumptions for the present study of the 10 TeV collider optics is that the main arc magnets generate a steady-state magnetic field up to 16 T in a 160 mm aperture. To reduce straight sections, and mitigate the effects from the high neutrino flux, the arc magnets are presently assumed to have combined functions (e.g. dipole/quadrupole and dipole/sextupole) [21]. The most recent optics requires dipole fields in the range of 10 T and gradients of 300 T/m. A simple combination of demands on field, gradient and aperture is presently beyond the feasible range of superconducting accelerator magnet technology and requires iteration. For the IR quadrupole magnets the assumption from the optics studies is of a peak field of 20 T, also associated with large apertures, up to 300 mm.

III. MAGNET STUDIES AND TECHNOLOGY OPTIONS

A. Target solenoid

MAP envisaged for the target solenoid a hybrid superconducting (SC) and normal conducting (NC) solution, consisting of a large bore Low Temperature Superconducting (LTS) magnet (approximately 15 T, 2400 mm bore) and a resistive NC insert (approximately 5 T, 150 mm bore) [25-27]. While this remains a possibility, the system stored energy (≈ 3 GJ), coil mass (≈ 200 tons), and wall-plug power consumption (≈ 12 MW, dominated by the resistive insert) are large. Following recent advances in HTS magnets for fusion [28] we

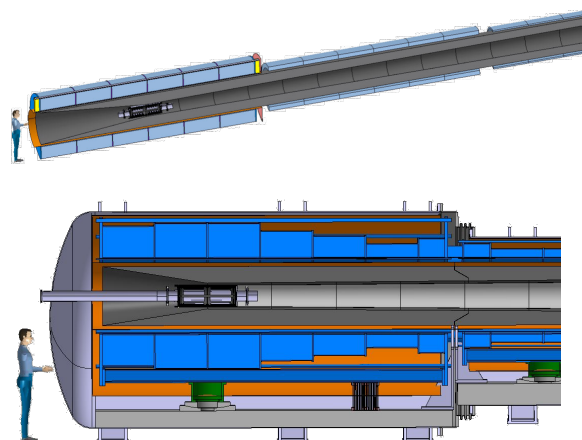

Fig. 2. Schematic view of the HTS target, decay and capture channel proposed (top), with a detail of the high field solenoids around the proton target area (bottom).

have proposed an alternative configuration based on an HTS cable operated at 20 K [29, 30]. The cable is inspired by the VIPER concept developed at MIT, validated in short sample tests in the SULTAN facility at Villigen (CH) [35]. A copper core with twisted REBCO tapes and a cooling hole is enclosed in a thick steel jacket that provides the main structural support. At the operating point of 61 kA, 21 T (peak field) and 20 K, the temperature margin is more than 10 K, which is ample for operation even when considering the radiation heat load. The coil, wound in double pancakes with insulated cable lengths, will require resorting to rad-hard impregnation. The analysis performed so far, reported in the references given above, shows that it is possible to eliminate the resistive insert and reduce the magnet bore to 1200 mm, about half of that of the US-MAP LTS coil, still producing the desired field profile for muon capture efficiency. Operation at temperature higher than liquid helium reduces the need to shield the radiation heat, maintaining good overall energy efficiency. Quench detection and protection can resort on classical techniques of voltage threshold (100 mV) and external energy dump (2.5 kV to ground) to achieve modest hot spot below 150 K, also profiting from the low-noise expected in steady state operation. The proposed system, shown schematically in Fig. 2, has a stored energy of ≈ 1 GJ, a coil mass of ≈ 100 tons and wall-plug power consumption of ≈ 1 MW, a considerable reduction with respect to the hybrid solution proposed earlier. We will focus in the future on specific HTS conductor and winding technology suitable for magnets of this class. The main challenge in this proposal is radiation damage of the superconductor and insulation, both requiring further analysis and optimization, measurements, and developments.

B. 6D Cooling solenoids

US-MAP has produced a complete layout of the sequence of 6D cooling cells. A total of 826 cooling cells is needed, subdivided in 12 types (cells A1 to A4, and B1 to B8). Each cell

TABLE I
SUMMARY OF MAIN SOLENOID CHARACTERISTICS FOR
THE 6D COOLING CELLS OF A MUON COLLIDER [15]

Cell	J_E (A/mm ²)	B_{peak} (T)	E_{Mag} (MJ)	e_{Mag} (MJ/m ³)	σ_{Hoop} (MPa)	σ_{Radial} (MPa)
A1	63.25	4.1	5.4	20.5	34	-4.6/0.0
A2	126.6	9.5	15.4	76.3	137	-28.3/0.0
A3	165	9.4	7.2	72.8	138	-28.5/0.0
A4	195	11.6	8.4	91.5	196	-49.4/0.0
B1	69.8	6.9	44.5	55.9	95	-13.5/0.0
B2	90	8.4	24.1	61.8	114	-20.1/0.0
B3	123	11.2	29.8	88.1	174	-36.6/0.0
B4	94	9.2	24.4	42.4	231	-23.5/19.7
B5	168	13.9	12	86.3	336	-55.7/21.1
B6	185	14.2	8.2	68.3	314	-43.1/22.3
B7	198	14.3	5.7	59.6	244	-37.4/20.7
B8	220	15.1	1.4	20.3	119	-22.9/22.1

is composed of an absorber, an RF module and two, four or six solenoids (depending on the cell) producing the required field profile.

We report in Tab. I the main parameters of each cooling cell type, including the main characteristics of the various solenoid families, and we show in Fig. 3 a synoptic of the field profile in all cells, to scale. Note how the field profile reverses in each cell, resulting in large repulsion forces among the solenoids in the same cell, powered in field opposition.

The solenoids in this version of the optics have a large variety, from large bore (over 1.5 m diameter) and modest field (2.6 T on axis) to small bore (90 mm diameter) and high field (13.6 T on axis). This corresponds to large stored magnetic energy (up to 44 MJ in the single cell B1), associated stress (up to 300 MPa hoop, as well as 20 MPa radial tensile in cells B5 and B6) and challenges for quench management (energy density up to nearly 100 MJ/m³ of coil in cell A4). Repulsion forces are in the range of a few to a few MN to tens of MN (37 MN in cell B3). Besides the challenges of each single solenoid, integration of solenoids within a cell, as well as in a string (the field of a cell leaks in the neighboring ones), is one of the principal difficulties of this part of the whole MuC.

Specific magnet technology (conductor, operating conditions, cooling) and manufacturing options have not yet been selected. Future work will be devoted to a revision of the coil configurations and coil designs, to mitigate the challenges identified, while at the same time integrating advances in beam optics studies. Standardization will also be considered to cope with the large number of solenoids to be built.

C. Final Cooling solenoid

A total of 17 final cooling cells were part of the scheme devised by US-MAP to achieve minimum beam emittance, with bore field up to 30 T. To improve upon the results obtained by US-MAP we are considering for the final cooling a solenoid design with the potential to reach and exceed 40 T, a clear bore of 50 mm, a magnet length of 500 mm, and sufficiently compact

in size as required for an accelerator magnet (considerations of mass, footprint, and cost) [31]. We are studying in particular a non-insulated (NI) REBCO winding solution, where the cooling solenoid is built as a stack of soft-soldered pancakes wound with a single 12 mm tape (alternative width and multiple tapes are considered). Given the high field performance required, we have set the operating temperature at 4.2 K. REBCO tapes for use in high field magnets, produced in industry, achieve presently extrapolated values of engineering critical current densities of 250 A/mm² in perpendicular 50 T field and 830 A/mm² in parallel 50 T field [31]. To reduce the coil size, as well as the forces and stored energy, we target a high operating current density for the central pancakes, in the range of 650 A/mm², i.e. less than 50% of critical (considering parallel field). This is within reach of present standard performance, especially considering on-going developments [36]. The resulting coil size is exceptionally small, with a 90 mm outer radius. Two critical issues were identified in the conceptual design phase, namely the stress state, and the selection and control of a transverse resistance which needs to be a good balance between the required ramp-rate and quench management.

The mechanics of the final cooling solenoid is designed to achieve a maximum hoop stress of 650 MPa and no tensile stress in any condition experienced by the coil, compatibly with the mechanical limits of industrially produced tapes. At this stage of the conceptual design, we do not consider other structural reinforcements than the tape substrate. The wound and soldered pancakes are loaded in radial direction by a stiff external ring that introduces a radial pre-compression of 200 MPa, at room temperature. This radial pre-compression is crucial to resist the large loads, and is chosen to nearly balance the outward electro-magnetic stress at 40 T. In fact, we have found that this is the field range at which a single pancake reaches the stress limits. Higher fields would require segmenting the coil in concentric and independently-supported layers, adding to the complexity and dimensions.

The stored energy density of the solenoid designed is about 300 MJ/m³, and the peak temperature in case of uniform quench of the whole solenoid would be a comfortable 200 K. The actual hot-spot temperature depends on the time it takes for the quench to propagate, governed by the electrical and thermal resistance among tapes. For the transverse resistance, our goal is to achieve quench protection through a low transverse resistance (possibly with means to actively trigger quench), while at the same time allowing full ramp in less than 6 hours, as well as field stability at flat-top better than 10 ppm/s. In addition to the mandatory quench analysis [37], work is in progress to find means to reduce the values typically obtained when soldering tapes. It is known that most of the current transfer in REBCO tapes takes place through the copper coating of the tape sides, and it was found that reducing or eliminating this part of copper greatly enhances the transverse resistance.

The rationale for the concept selected for the final cooling

1OrM1-1

solenoid, design studies, based on analytical, semi-analytical and FE analysis, as well as most recent work advances are reported in more detail elsewhere [31].

D. Synchrotrons (RCS and HCS) dipoles

As mentioned earlier, the principal challenge of the RCS and HCS's are the management of the multi-GW power required to pulse the resistive magnets, with good control of the field ramp shape, field homogeneity, and high energy efficiency. For a specified ramp time and shape, derived from beam design and RF limitations, the power required for pulsing is directly proportional to the magnetic energy stored in the ramped magnets. A lower bound for the stored energy is the magnetic energy in the beam aperture, a nominal 30 mm (gap) x 100 mm (width). To limit saturation, affecting losses and field quality, we have taken an upper design field limit of 1.8 T for the resistive magnets. This corresponds to a magnetic energy of 3.9 kJ/m in the beam aperture, while the energy stored in the magnet will be forcibly higher. The analysis of several resistive magnet configurations, of different iron cross section and materials, coil design and current density, shows that the lowest magnet stored energy is in the range of 5.4 kJ/m, a factor 1.4 higher than the magnetic energy in the beam aperture, quoted above [32]. A second issue is the magnitude of the resistive, eddy current and hysteresis loss. This is the power drawn from the grid and dissipated. A suitable target, though still preliminary, is in the range of 500 J/m per pulse, i.e. 10 % of the magnetic stored energy. This would result in total resistive losses around 80 MW, which is comparable to the present injector chain of the CERN accelerator complex. Among all configurations analyzed, we have found that the best compromise of stored energy, loss and field quality is obtained with a "H" and "Hourglass" shaped iron core [20]. These configurations will be retained for further magnetic analysis, including 3D and end effects.

It is important to remark that the design of the power converter goes hand in hand with the magnet design and analysis, seeking for an optimal cost solution (CAPEX+OPEX) [33], including considerations of beam dynamics and RF. The study of several powering configurations has allowed to identify two main cost drivers, namely the capacitor-based energy storage and the active filters required for the control of the ramp linearity and reproducibility. Targets for stored energy density and power conversion efficiency are still being formulated.

The steady state superconducting magnets of the HCS's still need to be developed. The specification for these magnets is still in discussion, but the fact that the aperture will be similar to that of the pulsed resistive magnets, i.e. 30 mm x 100 mm rectangular with large aspect ratio, calls for non-conventional windings. The cos-theta coil geometry customarily used in accelerator magnets is rather inefficient for such a rectangular aperture: a round aperture fitting the rectangular space required by the beam is associated with excess stored energy, material, and cost because of the unused space. This is why we have

directed conceptual work towards flat racetrack coils, simple and suitable for winding HTS tapes. It seems that it may be possible to achieve a field target around 10 T, at an operating temperature significantly above liquid helium in case HTS is used (10 to 20 K). This would be highly beneficial to cope with operating margin and efficiency requirements in HCS's, which tend to be rather "dirty" machines as far as beam losses are concerned. The concept development for these magnets is only at the beginning, but because of steady state operation, it may be possible to use also in this case a NI winding with benefits for quench protection. In fact, the concept of superconducting HCS magnet suggested above resembles closely on-going developments at associated laboratories [38].

Besides the use as steady bending magnets in the HCS stages, HTS magnets are also considered as an alternative for the pulsed dipoles in the last synchrotron. This stage requires ramp-rates of about 500 T/s, close to values recently demonstrated in a super-ferric dipole achieving a field of 0.3 T at 300 T/s [39]. The challenge is to demonstrate that fields of the order of 2 T, or higher, can be reached with acceptable AC loss. This study is presently only at a preliminary stage.

E. Collider arc and IR Magnets

As indicated earlier, the assumptions taken for the performance of the collider magnets that have been used to design beam optics are beyond state-of-the-art. Indeed, a crucial input to advance the study, in interaction with beam optics, is the definition of performance limits of accelerator dipole and quadrupole magnets. We have hence initiated an analytical evaluation of limits of operating margin, peak stress, and hot-spot temperature, under the assumption of a sector coil geometry and an upper magnet cost allowance [34]. Although the results are specific to this coil geometry, extension to other coil geometries is possible and will not significantly change the main outcome. We have used the analytical evaluation to produce design charts of maximum magnet aperture (A) vs. bore field (B), which is a form convenient for iterating with the beam optics. Such A-B charts were produced for a choice of superconductor and operating point of Nb-Ti at 1.9 K, Nb₃Sn at 4.5 K and REBCO either at 4.5 K or 20 K.

For a 10 TeV collider, Nb-Ti at 1.9 K does not appear as a good solution because of low operating margin (recall the large energy deposition), as well as considerations of cryoplant efficiency and energy consumption. Similarly, Nb₃Sn at 4.5 K falls short of the required field performance for the arc magnets, providing feasible solutions only up to 14 T. The operating margin, based on an enthalpy margin of 20 mJ/cm³ as for the HL-LHC magnets and resulting in a temperature margin of 2.5 K, results in a hard limit to the performance of magnets with material amounts within a set cost allowable of 400 kEUR/m. In addition, setting a maximum allowable transverse stress of 150 MPa yields to a maximum aperture of about 100 mm. Quench protection in this range of field and aperture seems feasible with standard detection and protection techniques.

Our initial evaluation of REBCO shows that also in this case

TABLE II
SUMMARY OF MAGNET DEVELOPMENT TARGETS

Complex	Magnet	Aperture (mm)	Length (m)	Field (T)	Ramp-rate (T/s)	Temperature (K)
Target, decay and capture	Solenoid	1200	19	20	SS	20
6D cooling	Solenoid	90...1500	0.08...0.5	4...15	SS	4.2...20
Final cooling	Solenoid	50	0.5	> 40	SS	4.2
Rapid cycling synchrotron	NC Dipole	30x100	5	± 1.8	500...4200	300
	SC Dipole	30x100	1.5	10	SS	4.2...20
Collider ring	Dipole	160...100	4...6	12...16	SS	4.2...20

the available design space does not match the required performance. For REBCO, however, operating margin is not an issue, and operation in the range of 10 K to 20 K could be envisaged, still allowing for a temperature margin of 2.5 K. Mechanics is also no longer the most stringent limit, provided one can profit from the good resistance of tapes to transverse stress (data shows single tape withstand up to 400 MPa with no degradation). The main limitations come rather from quench protection, associated with the cost of the superconductor. Cost considerations drive the current density in an all-HTS coil towards high values, in the range of 800...1000 A/mm², where standard detect-and-dump protection strategies are not sufficiently fast. It is hence clear that alternative protection schemes need to be devised to benefit from the large current carrying capacity and margin of present REBCO conductors. Provided that the cost per m of REBCO tape can be reduced by a factor three, relaxing the need for very high values of current density, we have found that a suitable design range for the arc magnets can be defined using two points, from a nominal aperture of 160 mm at reduced bore field of 12 T, up to nominal bore field of 16 T but reduced aperture of 100 mm. The whole range can be achieved with REBCO at 4.5 K and 20 K, while the low field range can be reached also with Nb₃Sn at 4.5 K, thus providing at least two technology options. In addition, REBCO at 10 to 20 K would be compatible with larger energy deposition in the coils, i.e. reduced shielding and smaller magnet aperture. A simple evaluation based on radiation studies shows that a 10 mm reduction in shielding thickness (20 mm in aperture) may be possible, with no penalty on wall-plug power, still at acceptable levels of radiation damage. Details on the methods, results and discussion can be found elsewhere [34].

The analytical evaluations discussed above are not intended as a magnet design, they lack any consideration on conductor geometry, coil winding and support, or manufacturing, to quote a few. But they provide much required guidelines towards the selection of suitable design points for the collider ring and IR optics. Our intention is to translate such selection of field, aperture and superconducting material into magnet design and engineering. This will be the focus of the upcoming work, extending the activities initiated by US-MAP [24]. We are using a similar approach to establish performance limits of quadrupoles (for the design of the interaction regions) as well as combined function magnets, as required because of the demand of neutrino flux mitigation.

IV. SUMMARY MAGNET PERFORMANCE TARGETS

We summarize the result reached so far in Tab. II, where we report the main performance targets and target ranges (i.e. not yet a specification) for the most challenging magnets of the MuC. They identify what we consider a feasible magnet performance range within the time scale of construction of a MuC. Though these targets are bound to adapt as the MuC study proceeds, they already provide a good basis to feedback on beam optics and accelerator performance, and to identify outstanding issues to be addressed by future work and dedicated R&D. It should be clear from the previous discussion, as also signified by the targets of Tab. II, that the work has a strong focus on HTS. A trivial reason is the required field reach, in particular for the target and final cooling solenoids that would not be possible otherwise. In this respect a hybrid LTS/HTS approach is not excluded, depending on the optimum of performance vs. cost. But a second reason for the focus on HTS, just as important, is also because of considerations of efficient cryogenic operation and helium inventory. Operation at temperature in helium gas in the range of 10 to 20 K can offer a coefficient of performance up to a factor four higher than a cryoplant producing liquid helium at 4.2 K. Higher energy efficiency is mandatory to cope with the energy deposition generated by the muon decay and ensuing cascades, which applies throughout the MuC complex.

Given the relatively young state of HTS magnet technology, we do not exclude that the range identified in Tab. II may still be conservative, and that it could be extended further. This will however require at the minimum a proof-of-principle, especially in the case of the dipole and quadrupole magnets needed by the collider. Such advances may take place on a timeline longer than envisaged for the first stage of realization of the MuC and could be considered for later upgrades.

V. CONCLUSIONS AND PERSPECTIVES

The conceptual design activities performed as part of the ongoing study of a Muon Collider, within the scope of the International Muon Collider Collaboration and supported by the EU through the MuCol design study, have led to a first baseline set for the main magnet performance parameters. These

1OrM1-1

parameters are an evolution of previous studies, in particular US-MAP, extending the feasible performance space by considering recent advances in superconductor and magnet technology, in particular HTS.

For the 6D and final cooling solenoid concepts selected, and along the lines outlined above, we have initiated supporting experimental activity. Tests are planned on HTS tapes and pancakes to provide an experimental basis for the electro-mechanical performance limits (stress and strain, as well as in-field measurement of delamination) and prove the feasibility of concepts.

As to the resistive dipoles for the RCS and HCS's, we will proceed with detailed design of the selected configurations and complement with measurement of magnetic material properties and loss in kHz range, as well as characterization of lifetime and required operating margin for the energy storage capacitors. We also wish to proceed with the definition of design concepts for the superconducting dipoles of HCS.

We plan to finalize the "A-B" charts for the SC dipoles and quadrupoles of the collider, adding the evaluation of feasible range of combined function gradient vs. dipole strength. After an iteration on the beam optics, we will then proceed with the study of designs for the collider arc dipole and combined function magnets, including stress management strategies to improve robustness and compensate for inevitable stress peaking factors. In addition, it will be interesting to explore a fast-track line for a reduced collider energy, in the range of 3 TeV as examined by US-MAP, based on the Nb₃Sn technology close to demonstration.

One of the issues that will need addressing soon is the effect of radiation on superconductors, specifically HTS. The radiation effects of the harsh and unique environment of a Muon Collider cannot be reproduced and tested in existing installation, so an evaluation of material response will need an understanding and scaling of existing and future data. For this specific issue we plan to rely on advances in material characterization for magnetically confined fusion.

In fact, and most important, the magnet technology for a Muon Collider has clear overlaps with other fields of magnet science. This, in itself, is a very strong motivator for present and future research and development with relevance to other scientific and societal applications such as:

- magnetically confined thermonuclear fusion;
- high magnetic field science;
- UHF magnets for nuclear magnetic resonance and research in magnetic resonance imaging;
- fast ramped magnets for radiation therapy;
- compact planar and non-planar coils for superconducting motors and generators.

This makes the Muon Collider a strong and motivating driver for advances in magnet science and technology.

REFERENCES

- [1] M. Boscolo, J. Delahaye, and M. Palmer, "The future prospects of muon colliders and neutrino factories," *Reviews of Accelerator Science and Technology*, vol. 10, no. 01, pp. 189–214, 2019.
- [2] C. Aimè, A. Apyan, M. A. Mahmoud, N. Bartosik, et al., "Muon collider physics summary," arXiv preprint arXiv:2203.07256, 2022.
- [3] D. Stratakis, N. Mokhov, M. Palmer, N. Pastrone, et al., "A muon collider facility for physics discovery," arXiv preprint arXiv:2203.08033, 2022.
- [4] J. de Blas, et al., "The physics case of a 3 TeV muon collider stage", <https://doi.org/10.48550/arXiv.2203.07261>.
- [5] K. Long, et al., "Muon Colliders: Opening New Horizons for Particle Physics", *Nature Physics*, v.17, p.289, 2021.
- [6] D. Neuffer and V. Shiltsev, "On the feasibility of a pulsed 14 TeV c.m.e. muon collider in the LHC tunnel", 2018 JINST 13 T10003.
- [7] D. Schulte, "The International Muon Collider Collabora-tion," in Proc. IPAC'21, pp. 3792–3795, JACoW Publishing, Geneva, Switzerland.
- [8] European Strategy Group, "2020 Update of the European Strategy for Particle Physics," tech. rep., Geneva, 2020.
- [9] C. Adolphsen, D. Angal-Kalinin, T. Arndt, M. Arnold, et al., "European strategy for particle physics–accelerator R&D roadmap," arXiv preprint arXiv:2201.07895, 2022.
- [10] MuCol Project, <https://mucol.web.cern.ch/>
- [11] R. Palmer, "Muon colliders," *Reviews of Accelerator Science and Technology*, vol. 7, pp. 137–159, 2014.
- [12] M. Palmer, "The US muon accelerator program," arXiv preprint arXiv:1502.03454, 2015.
- [13] L. Bottura, et al., "A Work Proposal for a Collaborative Study of Magnet Technology for a Future Muon Collider", 2022, <https://doi.org/10.48550/arXiv.2203.13998>.
- [14] H.K. Sayed and J. S. Berg, "Optimized capture section for a muon accelerator front end", *Physical Review Special Topics-Accelerators and Beams*, vol. 17, 070102, 2014.
- [15] D. Stratakis and R. Palmer, "Rectilinear six-dimensional ionization cooling channel for a muon collider: A theoretical and numerical study", *Physical Review Special Topics-Accelerators and Beams*, vol. 18, no. 3, p. 031003, 2015.
- [16] H.K.Sayed,R.B.Palmer,and D.Neuffer,"High field–low energy muon ionization cooling channel," *Physical Review Special Topics-Accelerators and Beams*, vol. 18, no. 9, p. 091001, 2015.
- [17] R. Palmer, R. Fernow, and J. Lederman, "Muon collider final cooling in 30–50 T solenoids", eConf. Proc. C110328, 2061 (2011).
- [18] F. Batsch et al., "Longitudinal Beam Dynamics and RF Requirement for a Chain of Muon RCSs", 14th Int. Particle Acc. Conf., 2023, doi: 10.18429/JACoW-IPAC2023-TUPA040
- [19] A. Chance et al., "Parameters Range for a Chain of Rapid Cycling Synchrotrons for a Muon Collider Complex", *Proceedings of 14th Int. Particle Acc. Conf.*, 2023, doi: 10.18429/JACoW-IPAC2023-MOPL162
- [20] J.S.Berg and H.Witte, "Pulsed synchrotrons for very rapid acceleration," in *AIP Conference Proceedings*, vol. 1777, p. 100002, AIP Publishing LLC, 2016.
- [21] K. Skoufaris, C. Carli, D. Schulte, "10 TeV Center of Mass Energy Muon Collider, *Proceedings of 13th Int. Particle Acc. Conf.*, 2022, doi:10.18429/JACoW-IPAC2022-MOPOTK031.
- [22] D. Calzolari et al., "Radiation Load Studies for Superconducting Dipole Magnets in a 10 TeV Muon Collider," *Proceedings of 13th Int. Particle Acc. Conf.*, pp. 1671–1674, JACoW Publishing, Geneva, Switzerland, 7 2022.
- [23] Y.I.Alexahin,E.Barzi,E.Gianfelice-Wendt,Kapin,etal., "Critical problems of energy frontier muon colliders: optics, magnets and radiation," arXiv preprint arXiv:2203.10431, 2022.
- [24] V.Kashikhin,Y.Alexahin,N.V.Mokhov,andA.V.Zlobin, "High-Field Combined-Function Magnets for a 1.5-1.5 TeV Muon Collider Storage Ring," in Proc. 12th Int. Particle Acc. Conf., pp. 3587–3589, JACoW Publishing, Geneva, Switzerland.
- [25] R. J. Weggel, et al., "Design Study for 20 T, 15 cm Bore Hybrid Magnet with Radiation-Resistant Insert for Pion Capture", *Proc. of 2001 Part. Acc. Conf.*, pp 3398-3400, 2001.
- [26] R. J. Weggel, et al., "A Target Magnet System for a Muon Collider and Neutrino Factory", *Proc. of 2nd Int. Part. Acc. Conf.*, pp 1650-1652, 2011.

1OrM1-1

- [27] R. J. Weggel, et al., "Magnet Design for the Target System of a Muon Collider/Neutrino Factory", Proc. of 5th Int. Part. Acc. Conf., pp 3976-3978, 2014.
- [28] MIT Pres release, MIT-designed project achieves major advance toward fusion energy, D. Chandler, 8 September 2021.
- [29] C. Accettura, et al., "Conceptual design of a target and capture channel for a Muon Collider", submitted for publication in IEEE TAS, 2024, unpublished.
- [30] L. Bottura, et al., "Design and analysis of a HTS internally cooled cable for the Muon Collider target and capture solenoid magnets", submitted for publication to Cryogenics, 2023, unpublished.
- [31] B. Bordini, et al., "Conceptual design of a ReBCO non/metal- insulated ultra-high field solenoid for the Muon Collider", accepted for publication in IEEE TAS, 2024, to appear.
- [32] M. Breschi, et al., "Comparative analysis of resistive dipole accelerator magnets for a Muon Collider", submitted for publication in IEEE TAS, 2024, unpublished.
- [33] F. Boattini, et al., "A Two Harmonics Circuit for the Powering of the Very Fast RCS (Rapid Cycling Synchrotron) of the Muon Collider Accelerator, 2023, Proceedings of 14th Int. Particle Acc. Conf., 2023, doi: 10.18429/JACoW-IPAC2023-WEPM078.
- [34] D. Novelli, et al., "Performance Limits of Accelerator Dipole and Quadrupole for a Muon Collider", accepted for publication in IEEE TAS, 2024, to appear.
- [35] Z. S Hartwig, et al., "VIPER: an industrially scalable high-current high-temperature superconductor cable", Supercond. Sci. Technol. 33 11LT01, DOI 10.1088/1361-6668/abb8c0.
- [36] A. Molodyk, et al., "Development and large volume production of extremely high current density YBa₂Cu₃O₇ superconducting wires for fusion", Scientific Reports 11(1), 2021, DOI:10.1038/s41598-021-81559-z.
- [37] T. Mulder, CERN, Private Communication, 2023.
- [38] L. Rossi, et al. "Design and plan of a 10 T HTS dipole for the Italian facility IRIS", accepted for publication in IEEE TAS, 2024.
- [39] H. Piekarz, et al., "Record High Ramping Rates in HTS Based Superconducting Accelerator Magnet", IEEE TAS, 32(6), 2022, 4100404.