

Review of High Voltage Direct Current Cables

George Chen, *Senior Member, IEEE*, Miao Hao, *Student Member, IEEE*, Zhiqiang Xu, *Member, IEEE*, Alun Vaughan, *Senior Member, IEEE*, Junzheng Cao, and Haitian Wang, *Member, IEEE*

Abstract—Increased renewable energy integration and international power trades have led to the construction and development of new HVDC transmission systems. HVDC cables, in particular, play an important role in undersea power transmission and offshore renewable energy integration having lower losses and higher reliability. In this paper, the current commercial feasibility of HVDC cables and the development of different types of HVDC cables and accessories are reviewed. The non-uniform electric field distribution caused by the applied voltage, temperature dependent conductivity, and space charge accumulation is briefly discussed. Current research in HVDC cable for higher operation voltage level and larger power capacity is also reviewed with specific focus on the methodologies of space charge suppression for XLPE extruded cables.

Index Terms—Accessory, conductivity, DC cable, HVDC, insulation, pulse electroacoustic method, space charge.

I. INTRODUCTION OF HVDC TRANSMISSION

LOWER costs in power transmission and distribution made possible by the invention of the power transformer in the late 1880s have led to the widespread prevalence of the alternating current (AC) transmission [1]–[6]. However, the dramatic increase in power demand and the expanding scope of human activity in recent years has also created an accelerated desire for more long-distance power transmission, power trades between asynchronous AC grids, and integration of renewable energy. In this context, high voltage direct current (HVDC) transmission, which has seen steady research and development over the past century, is currently seen as a viable option both as a competitor and as a supplement for AC technology.

Today, there are two types of power transmission mediums in use. They are naked conductor-based overhead lines, which are typically used for long distance power transmissions over land, and cables, which are used for underground and undersea power transmissions.

HVDC is seen as having several advantages over HVAC transmissions [6]–[10]:

- 1) HVDC lines involve lower capital costs (bipolar lines vs.

Manuscript received February 27, 2015; revised April 20, 2015; accepted May 8, 2015. Date of publication June 30, 2015; date of current version May 24, 2015. This work was supported by the State Grid Corporation of China: Research on Key Technologies of Insulation Material and Accessories for 320 kV HVDC XLPE Cable System (SGRIZLJS(2014)888).

G. Chen (e-mail: gc@ecs.soton.ac.uk), M. Hao, Z. Xu and A. Vaughan are with the Tony Davies High Voltage Laboratory, University of Southampton, United Kingdom.

J. Z. Cao and H. T. Wang are with State Grid Smart Grid Research Institute (SGRI), Beijing, China.

Digital Object Identifier 10.17775/CSEEJPES.2015.00015

three phase lines) and lower energy losses in long distance power transmission (see Fig. 1 for cable example).

- 2) They have power transmission and stabilization capabilities between unsynchronized AC networks, as well as the ability to prevent the transmission of faults between connected AC grids in terms of a “firewall.”

- 3) The HVDC power flow is fully controllable, rapid, and accurate. Moreover, the low voltage ride-through capability of VSC HVDC makes it more suitable for renewable energy integration.

- 4) For a fixed corridor, overhead HVDC transmission systems provide increased capacity.

- 5) For cable schemes, the lengths are not limited by charging currents and no reactive compensation (for the cable itself) is required at the end stations and/or at intermediate points, as in the case of AC transmission systems (see Fig. 1 for example).

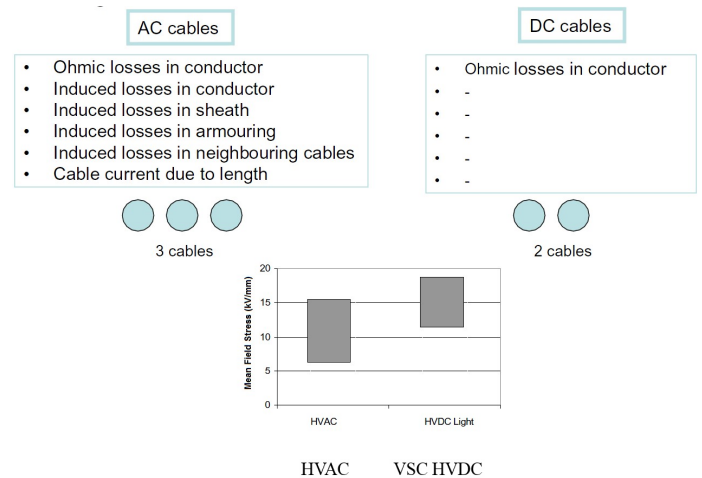

Fig. 1. AC and DC cable comparison [8].

A. HVDC Technologies

After the development of the high voltage mercury arc valve in the 1950s by Dr. A. U. Lamm [3] and the thyristor valve by English Electric and ASEA in the early 1970s [4], [5], both of which were necessary for large quantities of DC electric power transmission, HVDC technologies have gained steady attention and importance. According to their working principles, HVDC converter technologies today can be distinguished as line-commutated or current sourced converter technologies (LCC or CSC) and voltage sourced converter (VSC). LCC uses half-controllable thyristors as switching devices, whereas VSC uses

fully controllable devices, such as insulated gate bipolar transistors (IGBT), gate turn-off thyristor (GTO), or commutated thyristor (IGCT) as switching devices.

Thyristor based LCC requires a strong AC system in order to commute. Large amounts of reactive power compensators are required to compensate for the reactive power consumed by LCC HVDCs (For a typical LCC HVDC system, the amount of reactive power could be up to 76% of the real power transmitted.). Moreover, due to the trapezoidal-shaped converter and AC current and high component of DC bias, the HVDC converter transformer design is more complex and expensive compared to the conventional AC transformer. AC and DC filters are also required to minimize the high-frequency harmonics of LCC HVDC, which is shown in Fig. 2.

Prior to the development of VSC HVDC, LCC HVDC was critical for bulk power transmission over long distances through overhead lines or undersea cables, and for the integration of synchronized AC networks [10]–[12]. Commercial LCC HVDC projects with more than 5 GW power capacity and up to 800 kV have been in operations in China since 2010. Per the scheme, transmission distance is often over 2000 km [13].

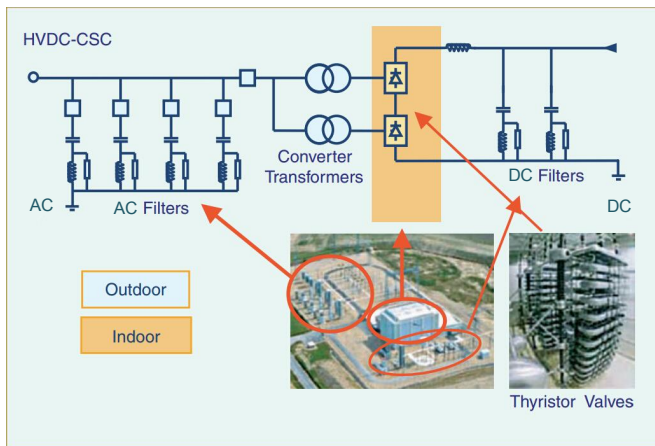

Fig. 2. Conventional HVDC with current source converters [7].

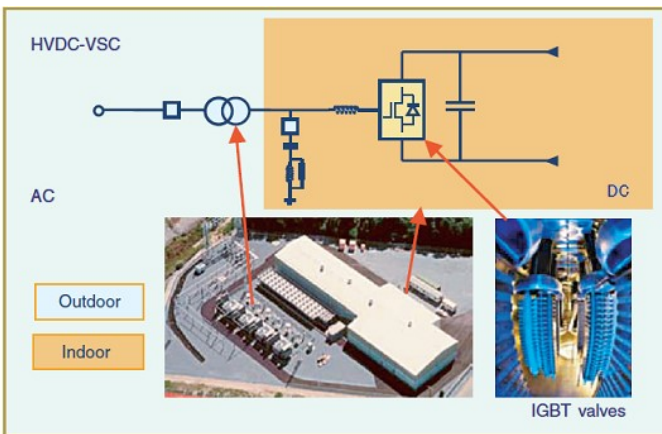

Fig. 3. HVDC with voltage source converters [7].

There are two different VSC topologies: the pulse-width

modulation (PWM) based VSC and the modular multilevel VSC (MMC). The PWM-based VSC was first proposed in 1990 [14] and the MMC VSC was commercialized for the first time in the 2010 [15]. Both VSC technologies use fully controllable devices such as IGBTs, GTOs, or IGCTs [16]. Due to its modular characteristic and lower switching losses, the MMC VSC technology has gradually replaced the PWM-based VSC technology and has become the major converter technology for VSC HVDC applications. VSC HVDC can quickly control both active and reactive power independently, and even permit black start. It can be used as a virtual synchronous generator in the AC system to improve overall system stability and performance. It can also minimize the impact of the low-voltage ride-through events of wind-farms on the connected AC grid. Moreover, there are virtually no high frequency harmonics in both converter AC voltage and current, so the converter transformer requirement is not a critical factor as it is for the LCC HVDC converter transformer; thus, no significant filters are required between the VSC converter and the converter transformer (refer to Fig. 3 for details). In addition, there is no VSC HVDC voltage reversal required even in the case of a power reversal, all of which makes VSC HVDC technology a preferred option for the construction of future DC grids.

The present limitations with the VSC technology are the voltage and current constraints of individual semiconductor devices [17]. For the same HVDC rating, a converter design using the VSC technology tends to be more expensive and larger, while incurring higher losses compared to a converter design using the LCC technology. Therefore, applications of VSC HVDC technology are presently limited to relatively lower power applications, as well as areas where VSC features are more important, such as low voltage ride-through capability for wind-farm integrations and the non-voltage reversal feature for future DC grid constructions [18]. The current state of commercial projects shows that the maximum voltage and power ratings for VSC HVDC have reached 500 kV and 2000 MW.

B. HVDC Cable Applications

Besides the core converter technologies of HVDC systems, high voltage cables are often applied for underground or undersea HVDC power transmission, including the integration of offshore renewable energy integrations.

Increased demand for renewable sources due to energy needs and climate issues has led to a growth in the number of wind farms worldwide. In Europe, offshore wind farms in the U.K. and the North Sea have been built or planned to meet the European climate and energy 20/20/20 targets, which include 1) reduction of greenhouse gas emissions by 20% compared to the 1990 levels; 2) increase share of the final-form consumption of renewable energy by 20%; and 3) improvements in energy efficiency by 20% [19]. In addition to the existing on-shore wind farm plans, Chinas National Energy Administration (NEA) has set an ambitious target to build up to 10.3 GW of offshore wind farms from 2014 to 2016 [20]. Similarly, based on the U.S. National Offshore Wind Strategy

prepared by the U.S. Department of Energys (DOE) office, a world-class offshore wind industry in the United States is to be established to achieve 54 GW of offshore wind deployment at a price of \$0.07 per kWh of energy by the year 2030, with an interim scenario of 10 GW at a price of \$0.10 per kWh of energy by 2020. A total of 72 offshore wind farm projects have been awarded more than \$300 million in capital investment from 2006 to 2014 in the U.S. [21], [22].

Long distance power transmission (above 70 km) across the sea and/or across offshore wind farms usually rely on HVDC submarine cables [23]. Underground DC cables are additionally desirable for urban areas to deal with right of way issues and respond to sharp increases in power demand accompanied by their rising costs. Moreover, underground cables also benefit to the general publics aesthetic sensibilities and living environment when compared with overhead lines [6]–[8], [24], [25].

C. Commercial Projects with HVDC Cables

In this section, some major operational cable HVDC projects are briefly reviewed. Newer HVDC projects under construction or currently ready to be installed with higher voltage level as well as longer distance and larger power capacity are also discussed in other sections of this paper.

The first truly commercial underground HVDC cable manufactured by Le Societ  des Cables de Lyon was installed in the early 1900s. This project was built for the transmission of power between the power station at Moutiers and the railway station in the city of Lyon. The 4-km-long cable system, used in conjunction with the overhead HVDC transmission lines, had a cable thickness of 18 mm mass impregnated paper (MI). The DC operating voltage and power for the cables were 125 kV and 30 MW, respectively [26], [27]. Since then, the mass impregnated paper insulation has become one of the most reliable and longest living dielectric material for HVDC cables.

The first HVDC submarine cable was installed for the Baltic Island HVDC project in 1954. It also used the MI insulated cable to transmit 20 MW of power at 100 kV voltage levels and over a 100 km distance between the Baltic island of Gotland and the Swedish mainland [27], [28]. The cable was then expanded to 150 kV and 30 MW in 1970, before finally going out of commission in 1986. The Baltic Island HVDC project was the first to use the thyristor valve technology [29].

A new era arrived when a 450 kV, 700 MW MI HVDC cable was first used in the NorNed HVDC connection scheme in 2008 to connect Norway and the Netherlands over a 580 km distance and to improve power trading [30].

The non-voltage reversal feature of the VSC HVDC technology is an added benefit, which has led to increase in the applications for extruded HVDC cables. This trend began in 1999 in Gotland, Sweden, where 50 MW wind power was delivered using two 70-km-long 80 kV extruded underground cables [25], [31]. Since then, the focus of research and development has shifted to extruded HVDC cables. In recently operational HVDC projects, the rated voltage of extruded cable was raised to 320 kV with up to 1000 MW capacity power,

as shown in Table I. A laboratory prototype of 525 kV XLPE HVDC cable is available in [32], [33].

TABLE I
HVDC PROJECTS WITH 320 kV EXTRUDED CABLES

Projet Name	Commission Year	Length (km)	Voltage (kV)	Capacity (MW)
DolWin1	2012	165	320	800
SylWin1	2014	205	320	864
INELFE	2014	64	320	2,000 2 HVDCs
Xiamen	2015	10	320	1,000

Fig. 4 shows the total lengths of different types of cables used from 1950 to 2015 [34]. It indicates that since 1950, the mass impregnated HVDC cables have been well accepted as the main insulation for HVDC applications, especially for submarine HVDC applications. With significant expansions occurring in the global HVDC cable market, applications of extruded cables have also increased dramatically in recent decades. Installation length of extruded cables today is similar to or even larger than mass impregnated cables, which shows a huge potential for extruded cables for future HVDC applications.

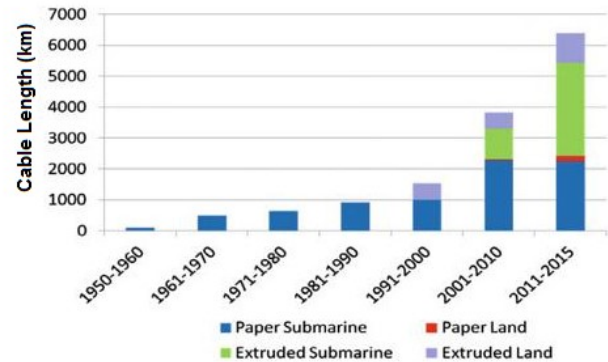

Fig. 4. Global HVDC projects in terms of cable length and in progress up to 2015 [25].

II. TYPES OF HVDC CABLES AND ACCESSORIES

Similar to AC cables, a typical HVDC cable usually consists of a conductor core, semiconductor screen, main insulation, sheath, armoring, and related accessories.

A. Different Insulation Systems

The different characteristics of dielectric materials typically lead to different electrical, mechanical, and thermal performances in cables. Therefore, the main types of HVDC cables based on different dielectrics are briefly introduced as follows:

1) *Oil-Filled DC Cable*: Oil-filled cable (OF), also known as fluid-filled cable, is usually filled with pressured oil in the oil channels. Multi-layer impregnated Kraft papers are used as the main insulation. There are two types of oil-filled cables.

The first type is filled with low viscosity oil that requires pressure feeding units and oil refill tanks to maintain the high oil pressure in the cable in order to avoid bubbles that can form in the oil. Therefore, the maximum practical length of this type of cable is just 30-60 km in order to keep a sufficient oil flow in the cable [23], [27]. For the second type, high viscosity oil is filled in the cable to maintain a flat pressure along the cable. Therefore, this so called self-contained OF cable does not need extra oil feeding units and theoretically the length of this type of cable can be unlimited [23], [35], [36]. The OF cable can be improved by applying polypropylene-laminated-paper (PPLP) as a matrix of insulation in cables, due to the higher DC and impulse breakdown strength, as shown in Fig. 5. Its performance can be seen in Japans 48.9 km long 500 kV, 2800 MW HVDC cable installed between Honshu and Shikoku island (Fig. 6) in 2000 [37], [38]. The potential capacity of the OF cable could be very large if the conductor could be cooled by oil. In the 1980s, the voltage rating of the OF cable reached 600 kV and was capable of being designed up to 1400 kV DC voltage [39]–[43]. However, due to the obvious disadvantages, e.g., limited cable length, requirements of oil feed equipment and the risk of oil leakage, OF cables were gradually replaced by MI cables or extruded HVDC cables.

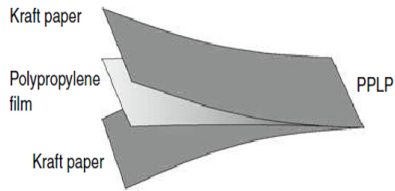
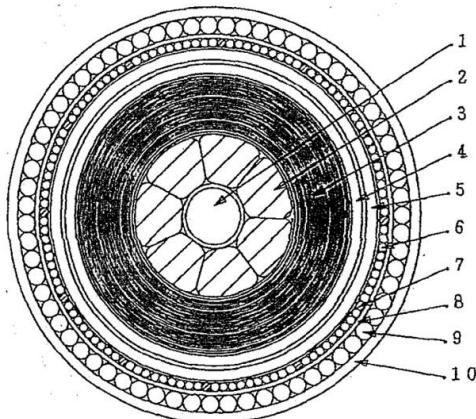

Fig. 5. Layers of PPLP [19].



- | | |
|---|------------------------|
| 1. Oil passage (25 mm ϕ) | 4. Lead alloy sheath |
| 2. Copper conductor
(7 segmental, 3000 mm ²) | 5. Polyethylene jacket |
| 3. Insulation ($t=22.5$ mm) | 6. Spacer |
| Kraft : 0.5 mm | 7. Optical fiber units |
| PPLP : 19.5 mm | 8. Bedding |
| Kraft : 2.5 mm | 9. Armour, zinc wire |
| | 10. Serving |

Overall diameter : Approx. 190 mm
Weight : Approx. 100 kg/m

Fig. 6. Construction of 500 kV DC PPLP oil-filled cable [44].

2) *Mass-impregnated Cable*: Similar to the OF cables, the main insulation of MI cables is also Kraft paper. However, MI cables usually can be defined as having “solid” insulation since there is no free oil contained in the cable, as shown in Fig. 7 [23]. High-density papers (≈ 1000 kg/cm³) are usually chosen to achieve possible higher dielectric properties, which are lapped under scrupulous environmental control and super clean conditions while being impregnated with a high viscosity compound based mineral oil. As a proven cable technology for HVDC for over 60 years, MI cables have shown the high performance and reliability in large HVDC power transmissions at up to 500 kV DC voltage, which is the highest HVDC voltage for the currently operational HVDC cable projects [45]. The length of MI cable in principle can be unlimited, because no external pressure and oil feeding system are required. Its insulation can be potentially improved by applying laminated polymeric film and paper, such as PPLP, to allow for a higher conductor temperature (85 °C) than the traditional MI cables (55 °C). This means that the power capacity of MI cables can be potentially enlarged [46]. Moreover, MI cables will not leak oil into the environment even when a complete cut happens, so the environmental impacts can be negligible [27]. A 385 km mass impregnated (improved by PPLP) submarine cable was applied in the Westernlink project for the first 600 kV subsea HVDC cable transmission project in the world, with a 2200 MW power capacity. This project is expected to be operating in 2015 [47].

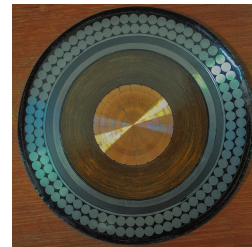

Fig. 7. HVDC MI cable.

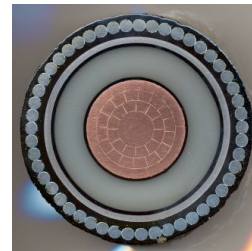

Fig. 8. HVDC extruded cable.

3) *Extruded DC Cable*: In contrast to the paper insulated cables, extruded HVDC cables (as shown in Fig. 8) use an extruded polymeric material as the main insulation, which is a relatively new development in DC cables. The major insulation material is cross-linked polyethylene (XLPE), which has been frequently utilized for both HVAC and HVDC cable insulations over the decades.

It is widely believed that extruded cables can offer many significant advantages [19], [23], [27], [43]: 1) Extruded cables

can withstand a higher operational temperature (up to 90 °C) allowing for more power to be carried for a given conductor cross section than MI cables; 2) The cables are generally mechanically robust and the weight is smaller; 3) The installation is simpler and faster due to the easier jointing process; 4) Extruded cables can avoid the environmental problem caused by oil leakage, and are recyclable. These benefits lead to continued rapid development of extruded cables.

Extruded HVDC cables have been successfully applied in many HVDC projects at up to 320 kV voltage rating and up to 1000 MW power rating [34], [48]. In 2002, researchers in Japan developed a 500 kV, 3000 MW (bipolar single circuit) extruded HVDC cable system in the laboratory [49]–[51]. Recently, ABB announced the first 525 kV extruded HVDC cable system with a power rating of up to 2600 MW [32]. By utilizing the improved XLPE material, extruded cables show a great promise in UHVDC power transmission. The main drawback, however, of extruded cables is the impact caused by space charge phenomena [6], [33], [52], [53]. The accumulated space charge can distort the electric field distribution in the insulation, leading to accelerated aging. The electric field could be greatly enhanced and cause permanent failure in the insulation during or shortly after polarity reversal. Therefore, the extruded cables are usually only used in the VSC HVDC technique as the fully controllable feature of power flow that allows reversal of power flow direction without changing the polarity of the HVDC DC voltage [34]. Issues related to space charge behavior and suppression, aging, and temperature and field dependent conductivity, all have been studied and continue to receive further scrutiny in order towards improving dielectric and thermal properties, and thereby enhancing the reliability and life time of extruded HVDC cables.

4) *Gas Insulated Cable*: Gas insulated cables are similar to oil-filled cables in that pressurized insulating gases are applied instead of oil. It is believed that the pressurized gas can support the submarine cable against the external water pressure, while increasing the electric strength with no limitations in the transmission length. Several gas insulated submarine cables installed in the 1960s have operated at up to 250 kV DC voltage, as shown in Fig. 9. Subsequently, this type of HVDC cable was rarely used [23], [54], [55].

Another type of gas insulated power transmission cable technology is called gas insulated line (GIL) system, as shown in Fig. 10. In such a system, conductors with large cross-sectional areas are used to ensure high power ratings and low losses. As the conductor is supported by the spacers in the outer tube, which is filled with an insulating gas mixture of mainly nitrogen and smaller percentage of SF₆ (sulphur hexafluoride), the GIL system is supported by a solid mechanical and electrical containment. The GIL system can be used on land to replace overhead lines. They also require less space and produce less environmental issues. GIL can also be used in a similar way as cables, but a permanent underground tunnel is necessary. Until now, GIL has not been commercially applied in HVDC projects, although it has been proposed for 800 kV UHVDC system applications [27], [56], [57].

5) *Superconducting Cable*: The development of superconducting materials has a long history. The unique electric and

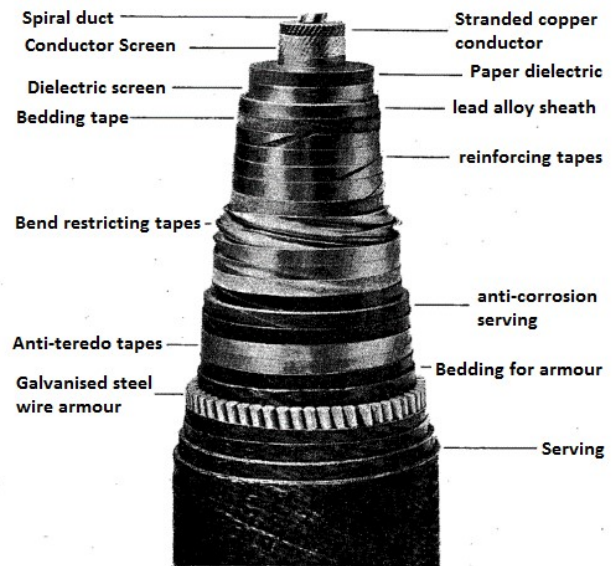

Fig. 9. Structure of gas filled cable [55].

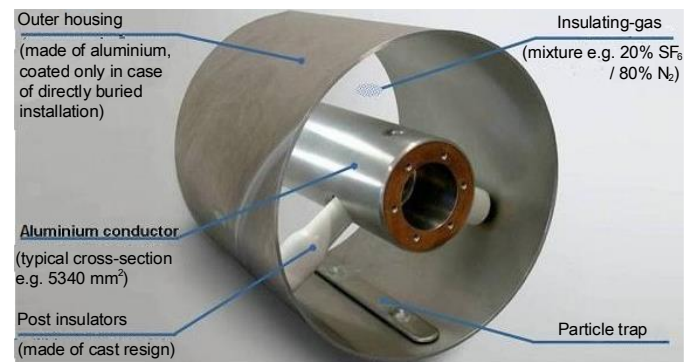

Fig. 10. Gas insulated line used for HVDC systems [57].

thermal properties superconducting materials have attracted considerable interest. Today, the more practical solution for HVDC superconductor cables is high temperature superconductor (HTS) DC cables. As shown in Fig. 11, liquid nitrogen is used as a cooling method, and the cryogenic enclosure where the cable is placed is commonly referred to as a cryostat. The space between the outer shield and the cryogenic enclosure is usually a vacuum containing layers of super-insulation. The refrigeration requirements for the DC superconductor cables are independent of the power flowing through the cable, since the cable itself generates no heat. The major length limitation of HTS cables is the requirements of refrigeration stations for cooling and liquid nitrogen flow. Although there are no commercialized HTS DC cables today, with still a need for HTS cable research and development, many studies have proposed the very high continuous power capacity HTS DC cable system in the range of 5 to 20 GW at 200 kV. Therefore, the application of HTS DC cable as a power transmission solution is more appropriate for very high power transmission situations [58]–[61].

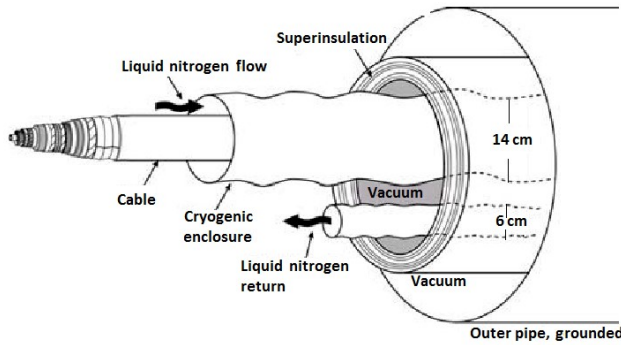

Fig. 11. Typical structure of HTS DC cable [59].

B. Accessories of HVDC Cables

As part of a complete HVDC cable system, cable accessories, i.e., joints and terminations are sometimes becoming the most critical parts due to the complex electrical, thermal and mechanical designs of these structures coupled with the high risks in environmental pollution and installer error [6]. Therefore, the accessories that can be reliably operated and easily installed play an important role in a robust cable transmission system.

Joints are frequently applied in an HVDC cable system for long distance power transmission. Many types of joints may be used in a cable route e.g., for production methods, there are factory joints and prefabricated joints and for different purposes, there are repair joints and transition joints. Similarly, the numbers of joints used in onshore cable systems and offshore cable systems are very different, e.g. for onshore extruded cable routes, large numbers of prefabricated joints (designed for easy installation in the field) are used due to transportation issues caused by the weight and size of cables exceeding 1–1.5 km. On the contrary, more factory joints (produced under factory conditions with the same electric and mechanical properties as cable) are used, and the total number of joints is greatly reduced due to the large capacity of cable laying vessels [6], [23].

Another cable accessory is termination, which is used at the ends of a cable routes to connect the cable with other equipment, e.g. overhead lines, busbars, and switchgears. Different types of cables have different structures of terminations, e.g. for oil-filled cables, an oil feed entry is needed in the termination; similarly, for mass-impregnated cables only a small vessel for oil expansion is needed [6], [23].

Unlike the accessories for an AC system, the HVDC accessories are required to withstand nominal DC stress, operating surge, lightning surge, and polarity reversal stress for LCC HVDC technology. One of most important tasks in the design of accessories is the optimization of electric field distribution within the accessories. However, this is not an easy task due to the characteristics of dielectric conductivity that varies with electric field and temperature (to be discussed in the next sections). Moreover, the space charge accumulation and its impact becomes much more unpredictable due to the complex geometry shape and structure of accessories as well as the

characteristics of interfaces, e.g., the interface between the cable insulation and joint insulation [19], [62], [63]. Therefore, more attention needs to be paid to the design of HVDC cable accessories due to these localized phenomena.

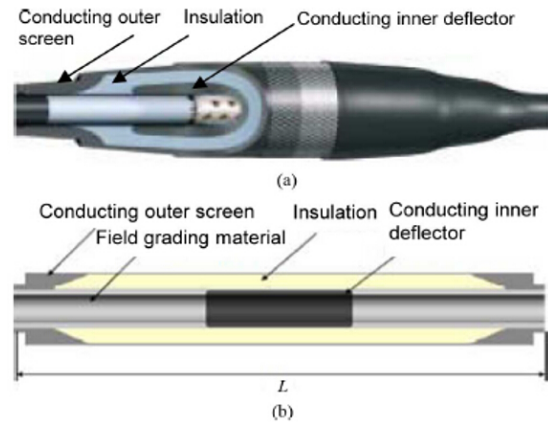

Fig. 12. Typical prefabricated joint design (a) without and (b) with dan FGM [19].

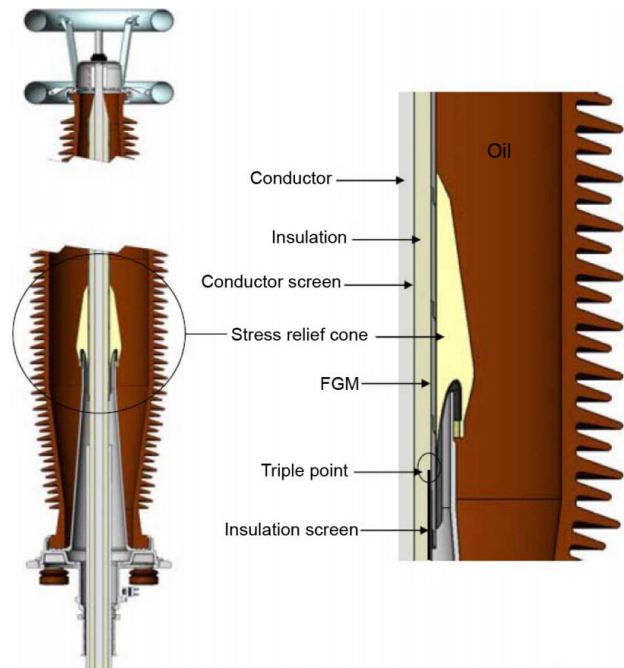

Fig. 13. Schematic cut-away view of an HVDC cable termination with FGM [19].

With the development of high voltage DC cables, especially extruded cables with up to 500 kV, the related designs and tests for accessories are also reported in [6], [19], [49], [64]. A special design for uniform electric field distribution is realized by applying resistive field grading materials (FGM), as shown in Fig. 12 and Fig. 13 [19], [65]. A more detail introduction of FGM can be found in [66], [67].

III. RESEARCH ON HVDC CABLE

Most of the developments in HVDC cables have been focused on the electric field distribution within the main

insulation of an HVDC cable. The field distribution is more complex under DC conditions due to not only the field and temperature dependent conductivity, but also the space charge phenomena. With the dramatic increases that have taken place in the voltage levels and power capacity of HVDC cables, high risks caused by distorted electric field distribution become unacceptable. Moreover, many international standards for design and tests under HVDC conditions need to be revised with additional research in HVDC cables. For example, the CIGRE working groups have proposed new recommendations for testing HVDC cables above 500 kV based on extensive recent research related to HVDC cables, particularly in the area of space charge effects. In this paper, two main reasons that cause the inhomogeneous electric field distribution in the main insulation of HVDC cables are discussed in the sections that follow.

A. Electric Field Inversion in HVDC Cables

Unlike AC cables, the DC electric field distribution in HVDC cables is dependent on dielectric conductivity and space charge effects. If the build-up of space charge in the insulation is only caused by the inhomogeneous conductivity and permittivity of the dielectric material, i.e., it ignores other mechanisms of space charge generation, (such as charge injection and depolarization), then the electric field distribution can be said to be governed by the DC conductivity of the insulation at the steady state. It is well known that the DC conductivity of the main insulation is related to the applied field and temperature. Generally, for a same radius of cable insulation, a higher electric field and/or a higher temperature can lead to a larger conductivity. [6], [19], [23], [33], [52], [68]–[70]. The relationship of σ with E and T can be expressed as:

$$\sigma(T, E) = \sigma_0 \exp(-E_a/kT) \sinh(bE)/E \quad (1)$$

where σ_0 is a constant, E_a is the thermal activation energy governing the temperature dependence of the conductivity, k is Boltzmann's Constant, T is the absolute temperature, b is a constant, and $\sinh(h(bE)/E)$ is the field dependence of conductivity.

As shown in Fig. 14, when the DC field is first applied, the electric field distribution is similar to the geometry of the AC cables, and is called Lapacian or capacitive field distribution. In this transient time, the field distribution is mainly decided by the permittivity of the insulation. The insulation close to the conductor withstands the highest electric stress, and the stress is gradually decreased from the inner side of the insulation to the outer side. This phenomenon usually happens when the cable system is energized initially at no load and the cable is isothermal. When the DC voltage is applied for a period of time and the cable is still isothermal, the conductivity of the insulation will change under different local electric fields. The inner insulation withstands the higher electric field, so the conductivity in this area starts increasing, leading to a stress reduction in the inner insulation and a stress rise in the outer insulation. This could be positive if the change in stress is appropriate.

The electric field distribution across the insulation tends to be uniform, i.e., the highest stress at the inner side near

the conductor drops. When considering the temperature effects, it is expected things will be more complicated. Once current flows through the conductor, a temperature gradient is established across the insulation. The highest temperature is at the inner side near the conductor, and the lowest part is the outer side away from the conductor. Under these circumstances, the conductivity of the inner insulation will increase further; therefore, the electric field near the conductor will decrease considerably, but increase in the outer area. Due to large temperature gradients (generally when the cable is fully loaded), the electric field can be reversed so that the highest stress transfers from the inner insulation to the outer insulation. This electric field inversion limits the temperature rating of HVDC cables. It is very important, therefore, to calculate the stress distribution at different operational stages taking into consideration different environmental factors, due to the high dependence between conductivity and temperature, as well as the time constant for reaching steady state and temperature [41]. This is one of most important motivations for developing insulation materials with high thermal conductivity and less temperature-dependent dielectric properties.

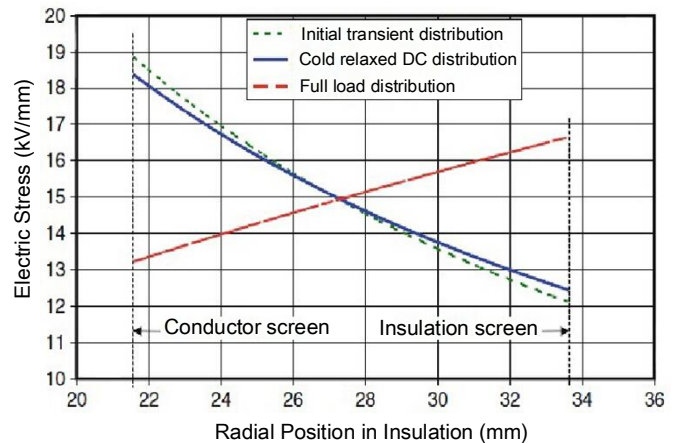

Fig. 14. Electric stress in DC cable insulation under different load conditions [23].

B. Space Charge Effects in HVDC Cables

Most HVDC equipment suffers from the space charge phenomena, which can distort the electric field distribution within the insulation bulk, leading to accelerated aging and eventual breakdown. Particularly, after polarity reversal, the presence of space charge can lead to considerable electric field enhancement that is usually not acceptable and can easily cause failure in the insulation [71]–[74]. Many studies suggest that the accumulation of space charge could lead to severe impacts on the solid dielectrics, especially polymeric insulation [63], [75]–[87]. The origins of space charge generally can be concluded as follows: 1) charge injection from electrode to the insulation bulk and 2) ionization of the impurity, dissociable additives and cross-linking by-products under DC voltages. The injection of charge carriers occurs at the conductor/solid insulator interface when the applied electric field is higher than the threshold field for the specific

dielectric material. For example, the threshold for PE is about 10 kV/mm [88]–[90]. The injected charge carriers are expected to have the same polarity of the related electrode, i.e., positive charges are injected from the anode, and negative charges are injected from cathode, which is called homo-charges. It has also been proven that the charge injection process is highly related to the effects caused by the semiconductor screen, i.e., the characteristics of semiconductive materials and the combination of different types of semiconductive materials and dielectric materials can improve the threshold for space charge injection while reducing the amount of accumulated charges under certain environmental conditions [80]. On the other hand, the charge carriers generated by the ionization process, such as XLPE by-products, could be extracted by the electrodes. The positive charges will be extracted by the anode, which move and accumulate near the anode; the negative charges will work conversely. In this way, hetro-charges are formed. The ionization can occur under low electric field. When a DC field that is higher than the threshold is applied to the solid insulation, both ionization and injection processes are expected to occur, and the final space charge profile will be the competition between these two processes. It is generally believed that the presence of homo-charges can reduce the electric field at the interface between electrode/insulator, but enhance the electric field in the bulk of the insulator; in contrast, the hetro-charges can increase the electric field at the surface of the insulator. The concept of homocharge and hetrocharge is shown in Fig. 15.

The space charge behavior in PE materials has been studied for over 50 years; it has been proven that the charge density and movement are dependent on multiple factors, such as the amplitude and duration of the applied electric field, temperature, moisture content, electrode material, interface condition between conductor and polymer, geometry of the polymer and material properties, chemical composition, morphology, impurities and additives, and aging status. Many numerical models have been proposed to simulate the space charge behavior in polymeric materials [91], [92].

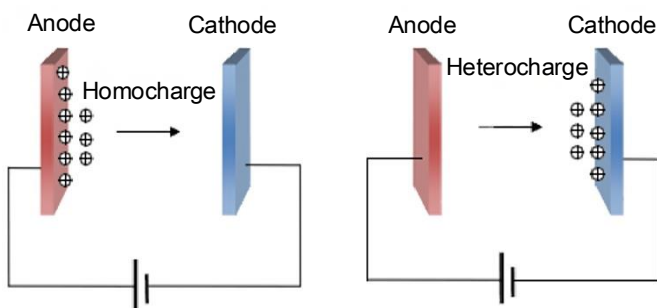

Fig. 15. The concept of homocharge and hetrocharge.

To investigate space charge, both destructive and non-destructive techniques have been in use since 1970s. They include thermal pulse method (TPM) [93], thermal step method (TSM) [94], laser intensity modulation method (LIMM) [95], pressure wave propagation method (PWP) [96], laser-induced pressure pulse method (LIPP) [97] and the pulse electroacoustic method (PEA) [98]. Today, the PEA method is one of most

popular measurements for evaluating dielectric materials on space charge behavior; this method can also be modified and improved for different purposes. In [71], [73], [99]–[103], the space charge behavior in real extruded cables is investigated using the modified cable PEA system, as shown in Fig. 16. The temperature gradient effects in cables have also been successfully studied [71], [73], as shown in Fig. 17.

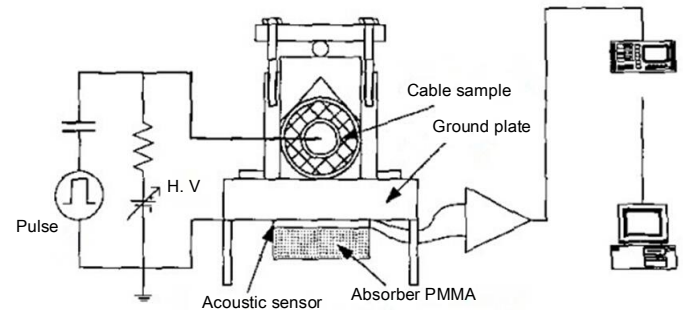

Fig. 16. Schematic diagram of modified cable PEA system with flat ground electrode [99].

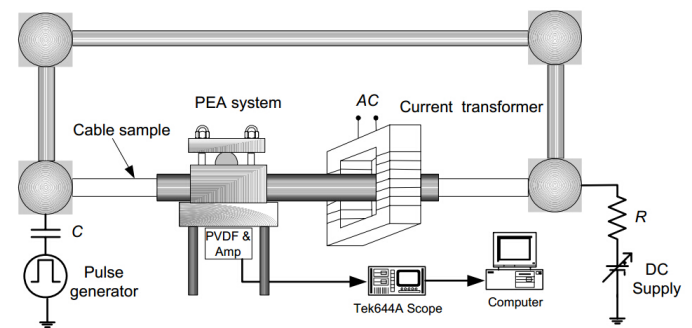

Fig. 17. Schematic diagram of PEA system for cable geometry with temperature control system [71].

C. Direction of HVDC Cable Research and Development

To overcome the main issues related to stress inversion and space charge accumulation, some desired characteristics of polymeric insulation are highlighted as follows [6]:

- 1) Dielectric conductivity must be less dependent on temperature, amplitude, and duration of electric stress.
- 2) Thermal conductivity must be large for cooling and small temperature gradient.
- 3) Space charge accumulation must be minimized.
- 4) High DC breakdown strength is required under high temperature and polarity reversal conditions.

To meet these requirements on future HVDC cables, the development of dielectric materials, especially the properties of XLPE, is briefly reviewed in this section.

1) *Modifying of Electrode/Insulation Interface*: In order to limit the charge injection from electrodes, several methods have been proposed to modify the properties of electrodes/insulation interface, including the semiconductor screen [6]. They are as follows:

- 1) A space charge suppression layer has been built adjacent to the conductor at the electrode/insulation interface by

- using the materials that are difficult for space charge injection, e.g. polyethylene terephthalate (PET) [6], [48].
- 2) Types and/or weight percentages of carbon black in the semiconducting layer have been modified. It has been reported that the space charge injection can be suppressed by the inclusion of carbon black with 10–50 wt%, and the acetylene carbon black can supply superior space charge properties compared with the standard furnace carbon black. [6], [33], [104].
 - 3) Different types of semiconducting layer and polymers are combined. Some studies show impacts of the different combinations of semiconducting layers and polymers, including polar and non-polar polymers, based on the space charge distribution. Therefore, as a whole insulation system, both types of dielectrics and semiconductive material are important for the electric properties and space charge behavior, as shown in Fig. 18 [104]–[106].
 - 4) Fluorination treatment on the surface of polymeric insulation can affect the electric properties as well as control the space charge behavior in PE. The space charge profiles indicate the effect caused by the fluorinated layer is highly related to the conditions of the fluorination process, such as the concentration of F_2 , the time duration for fluorination process, especially when a low level volume of O_2 is mixed [6], [107], [108].

2) *Using Additives or Fillers:* Research and application of additives or fillers used in polymers to improve the specific electric, chemical, thermal and mechanical properties have been attracting attention. Several additives applied in HVAC XLPE cables can also be successfully applied in HVDC cables, such as cross-linking agents, antioxidants, and scorch retardants [6], [52], [33]. The space charge could be suppressed by reducing the production of polar by-products, such as acetophenone and cumyl alcohol.

Another development in an effort to reduce the impacts caused by space charge is by adding nanocomposite fillers to PE based dielectric materials. Many studies have indicated that these nanocomposites can bring unique characteristics to the polymer, e.g., SiC and BaTiO₃ composites have been employed as field grading materials and ZnO is an excellent surge arrester additive because of its high field dependent conductivity and permittivity [109]–[115]. In Japan, a 500 kV HVDC XLPE cable has been developed based on the homogeneously dispersed nano-sized MgO-filler, as shown in Fig. 19 [50], [51], [116]. However, the performance of the nanocomposite-filled insulation is not only dependent on the types of nano-particles, but other complexities, such as size, concentration levels, surface treatment, dispersion, moisture, and temperature. Although the mechanism of nano-filler function is still not fully understood, the function of nano-particles can be treated as deep traps that capture charges and reduce the charge mobility in order to suppress further space charge injection. It can be expected that as the fundamental understanding of nanodielectric properties improves, additional functional nanodielectrics with superior electrical, thermal, mechanical properties for HVDC applications will be

developed.

3) *Improving the Cleanliness of XLPE:* The conductivity of dielectric material is highly dependent on the presence of polar molecules assisting in the charge transportation, i.e., the numbers, charge, and mobility of the charge carriers. Therefore, one way to reduce the conductivity is to decrease the concentration of potential charge carriers or polar substances assisting charge transport. Considering the relationship between space charge trapping and defects in dielectrics, i.e., the physical defects and chemical defects that form the traps to restore space charge, it is important to decrease the chemical and physical defects in the insulation, which requires a highly clean physical and chemical environment during both the production and transportation processes [83], [117]–[121]. It has been reported that a superior electrical performance XLPE extruded cable with high level of chemical and physical cleanliness is commercially available for 525 kV HVDC transmission [32]. To minimize the chemicals introduced into XLPE during the processing, quality control is carefully applied during the full production cycle, leading to a number of outcomes, e.g., the effect of process chemicals on the conductivity of the base resin, reduced amount of peroxide decomposition products, and careful selection and optimization of all additives [122],

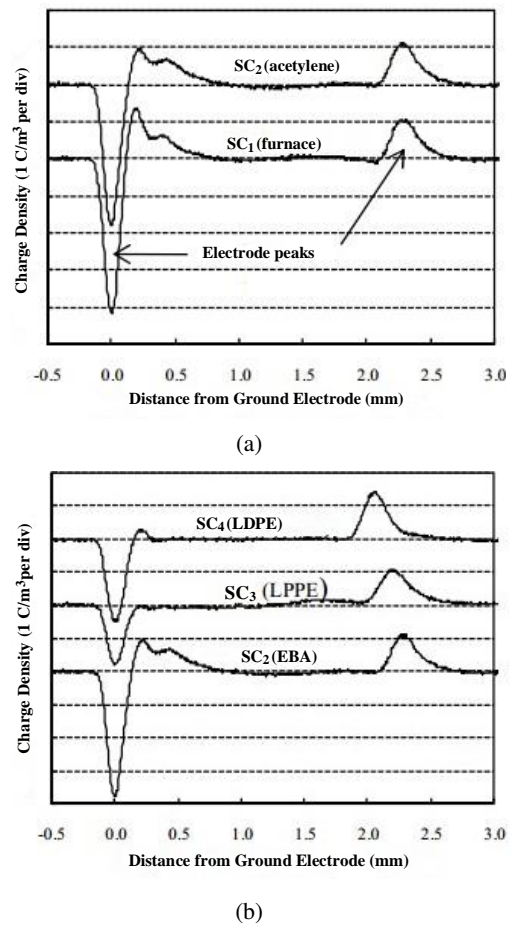

Fig. 18. Space charge distributions showing (a) the influence of type of carbon black in the semiconductive material and (b) the influence of type of polymer in the semiconductive material, where SC₁: EBA + furnace black, SC₂: EBA + acetylene black, SC₃: LPPE + acetylene black, SC₄: LDPE + LPPE (10% by weight) + acetylene Black [104].

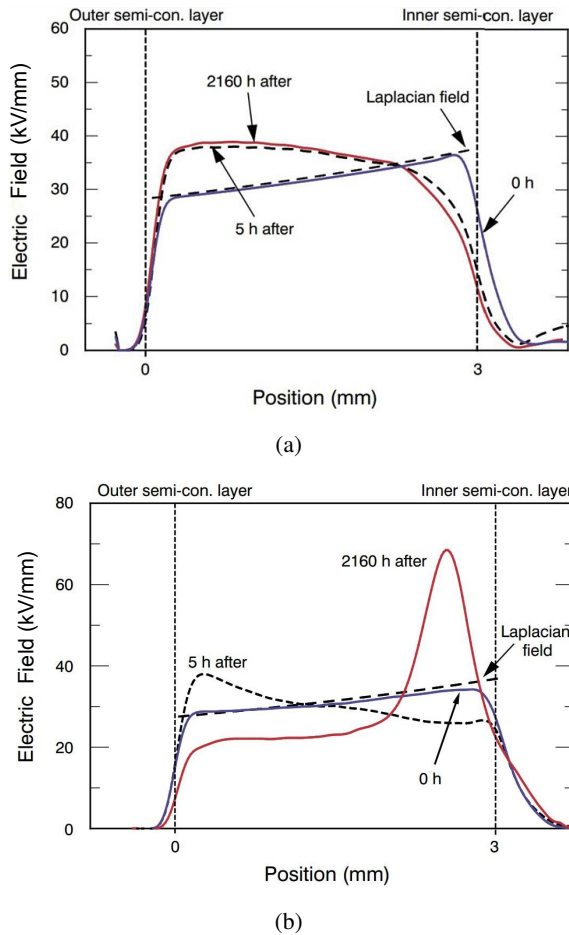

Fig. 19. Electric field distribution in (a) DC XLPE cable and (b) AC XLPE cable under HVDC voltage [51].

[123]. This is in conjunction with a complete manufacturing and transportation process within the highest level of a clean environment to avoid the possible impurities.

IV. CONCLUSION

This paper provides a brief review of the state-of-the-art of HVDC cable transmission technologies with the following observations:

1) Increased demand for renewable energy integration and robust interconnected power networks for power trading has increased the importance of HVDC cables in the global power industry.

2) Global HVDC commercial projects have shown that the two main types of HVDC cables with wide commercial applications are MI cable and extruded XLPE cables. As a proven technology, MI cables deliver DC power up to 500 kV over long distance. The applications of extruded XLPE cables, on the other hand, have dramatically increased in the recent years due to significant advantages in manufacturing, installation, and transportation and maintenance. 525 kV extruded XLPE HVDC cables are now commercially available, although 320 kV is the highest voltage level in the operational projects until now.

3) In this paper, the two main issues related to HVDC cables are addressed, i.e., stress inversion and space charge effect. These two issues reflect the importance of the temperature and electric field dependent conductivity in dielectric materials. The critical influences caused by space charge accumulation may be permanent in polymeric insulation, and lead to a high electric field enhancement after polarity reversal.

4) Some methods for improving the performance of HVDC cables, especially space charge suppression, are also reviewed. Both applications of nanocomposites and ultra-clean XLPE show a possibility in future HVDC cables with ultra-high voltage rating.

REFERENCES

- [1] E. W. Kimbark, *Direct Current Transmission*. John Wiley & Sons, 1971, vol. 1.
- [2] D. C. T. Links, D. C. Side, and C. Stations, "Power transmission by direct current," 1975.
- [3] W. Long and S. Nilsson, "HVDC transmission: yesterday and today," *IEEE Power and Energy Magazine*, vol. 5, no. 2, pp. 22–31, 2007.
- [4] ALSTOM, "HVDC: Connecting to the Future," Alstom, 2010.
- [5] J. Arrillaga, *High voltage direct current transmission*. Institution of Electrical Engineers, 1998.
- [6] G. Mazzanti and M. Marzintotto, *Extruded Cables for High-Voltage Direct-Current Transmission: Advances in Research and Development*. John Wiley & Sons, 2013, vol. 93.
- [7] M. P. Bahrman and B. K. Johnson, "The ABCs of HVDC transmission technologies," *IEEE Power and Energy Magazine*, vol. 5, no. 2, pp. 32–44, 2007.
- [8] M. Jeroense, "HVDC, the next generation of transmission: highlights with focus on extruded cable systems," *IEEE Transactions on Electrical and Electronic Engineering*, vol. 5, no. 4, pp. 400–404, 2010.
- [9] A. Siemens. (2011). Energy development strategic action plan. [Online]. Available: http://www.siemens.com/sustainability/pool/en/environmental-portfolio/products-solutions/power-transmission-distribution/hvdc_proven_technology.pdf.
- [10] C. K. Kim, V. K. Sood, G. S. Jang, S. J. Lim, and S.-J. Lee, *HVDC Transmission: Power Conversion Applications in Power Systems*. John Wiley & Sons, 2009.
- [11] B. Andersen and C. Barker, "A new era in HVDC?" *IEE Review*, vol. 46, no. 2, pp. 33–39, 2000.
- [12] R. Majumder, C. Bartzsch, P. Kohnstam, E. Fullerton, A. Finn, and W. Galli, "Magic bus: High-voltage DC on the new power transmission highway," *IEEE Power and Energy Magazine*, vol. 10, no. 6, pp. 39–49, 2012.
- [13] J. Cao and J. Y. Cai, "HVDC in China," presented at EPRI 2013 HVDC & FACTS Conference, USA, 2013.
- [14] A. Abbas and P. Lehn, "PWM based VSC-HVDC systems—a review," in *IEEE PES Power & Energy Society General Meeting*, 2009, pp. 1–9.
- [15] T. Westerweller, K. Friedrich, U. Armonies, A. Orini, D. Parquet, and S. Wehn, "Trans bay cable—world's first HVDC system using multilevel voltage-sourced converter," *Proceedings of CIGRE*, Paris, France, 2010, B4-101.
- [16] E. M. Callavik, P. Lundberg, M. P. Bahrman, and R. P. Rosenqvist, "HVDC technologies for the future onshore and offshore grid," in *CIGRE Session*, Paris, France, 2012, pp. 1–6.
- [17] D. Jacobson, P. Wang, C. Karawita, R. Ostash, M. Mohaddes, and B. Jacobson, "Planning the next nelson river HVDC development phase considering LCC vs. VSC technology," in *CIGRE Session*, Paris, France, 2012, p. 68.
- [18] O. Saksvik, "HVDC technology and Smart Grid," in *9th IET International Conference on Advances in Power System Control, Operation and Management (APSCOM 2012)*. IET, 2012, pp. 1–6.
- [19] H. Ghorbani, M. Jeroense, C.-O. Olsson, and M. Saltzer, "HVDC cable systems—highlighting extruded technology," *IEEE Transactions on Power Delivery*, vol. 29, no. 1, pp. 414–421, 2014.
- [20] China National Energy Administration, "Development plan (2014–2016) for national offshore wind power," 2014.
- [21] U.S. Department of Energy, "A national offshore wind strategy: creating an offshore wind energy industry in the United States," 2011.
- [22] U.S. Department of Energy, "Offshore wind projects," 2014.

- [23] T. Worzyk, *Submarine power cables: design, installation, repair, environmental aspects*. Springer Science & Business Media, 2009.
- [24] B. M. Weedy, *Underground Transmission of Electric Power*. John Wiley & Sons, 1980.
- [25] M. Byggeth, K. Johannesson, C. Liljegren, L. Palmqvist, U. Axelsson, J. Jonsson, and C. Tornkvist, "The development of an extruded HVDC cable system and its first application in the Gotland HVDC Light project," in *Proceedings of Fifth International Conference on Insulated Power Cables, JICABLE*, 1999, pp. 538–542.
- [26] T. Worzyk, "100 years of high voltage DC links," *Modern Power Systems*, pp. 21–22, Nov., 2007.
- [27] R. Liu, "Long-Distance DC electrical power transmission," *IEEE Electrical Insulation Magazine*, vol. 29, no. 5, pp. 37–46, 2013.
- [28] E. Iltad, "World record HVDC submarine cables," *IEEE Electrical Insulation Magazine*, vol. 10, no. 4, p. 64, 1994.
- [29] C. Facchin and H. Fässler, "60 years of HVDC," *ABB Review*, Special Report, vol. 9AKK106103A7819, 2014.
- [30] J. Skog, H. v Asten, T. Worzyk, and T. Andersrod, "NorNed—world's longest power cable," in *CIGRE Session*, Paris, France, 2010.
- [31] U. Axelsson, A. Holm, C. Liljegren, K. Eriksson, and L. Weimers, "Gotland HVDC light transmission—world's first commercial small scale DC transmission," in *CIGRE Conference, Nice, France*, vol. 32, 1999.
- [32] A. Gustafsson, M. Saltzer, A. Farkas, H. Ghorbani, T. Quist, and M. Jeroense, "The new 525 kV extruded HVDC cable system," *ABB Technical Paper*, 2014.
- [33] T. L. Hanley, R. P. Burford, R. J. Fleming, and K. W. Barber, "A general review of polymeric insulation for use in HVDC cables," *IEEE Electrical Insulation Magazine*, vol. 19, no. 1, pp. 13–24, 2003.
- [34] G. Migliavacca, *Advanced Technologies for Future Transmission Grids*. Springer Science & Business Media, 2012.
- [35] F. Miranda and P. G. Priarroggia, "Self-contained oil-filled cables. a review of progress," in *Proceedings of the Institution of Electrical Engineers*, vol. 123, no. 3. IET, 1976, pp. 229–238.
- [36] C. Arkell and A. Parsons, "Insulation design of self contained oil-filled cables for DC operation," *IEEE Transactions on Power Apparatus and Systems*, vol. 101, no. 6, pp. 1805–1814, 1982.
- [37] S. Koyama, H. Uno, K. Fujii, S. Gouda, I. Shigetoshi, Y. Nakamura, S. Sumiya, Y. Shimura, T. Maruyama, and S. Suzuki, "DC +/-500 kV oil-filled submarine cable crossing kii-channel," *Fujikura Technical Review*, vol. 30, pp. 45–55, 2001.
- [38] A. Fujimori, K. Fujii, H. Takashima, H. Suzuki, M. Mitani, O. Fujii, I. Shigetoshi, and M. Shimada, "Development of 500 kV DC PPLP-insulated oil-filled submarine cable," *Electrical Engineering in Japan*, vol. 120, no. 3, pp. 29–41, 1997.
- [39] G. Bahder, G. Eager, G. Seman, F. Fischer, and H. Chu, "Development of ± 400 kV– ± 600 kV high and medium-pressure oil-filled paper insulated DC power cable system," *IEEE Transactions on Power Apparatus and Systems*, no. 6, pp. 2045–2056, 1978.
- [40] G. Luoni, E. Occhini, and B. Parmigiani, "Long term tests on a ± 600 kV DC cable system," *IEEE Transactions on Power Apparatus and Systems*, vol. PAS-100, no. 1, pp. 174–183, Jan 1981.
- [41] G. Bianchi, G. Luoni, and A. Morello, "High voltage DC cable for bulk power transmission," *IEEE Transactions on Power Apparatus and Systems*, vol. 99, no. 6, pp. 2311–2317, 1980.
- [42] E. Allam and A. McKean, "Laboratory development of ± 600 kV DC pipe cable system," *IEEE Transactions on Power Apparatus and Systems*, vol. 100, no. 3, pp. 1219–1225, 1981.
- [43] D. Couderc, Q. Bui-Van, A. Valle, R. Hata, K. Murakami, and M. Mitani, "Development and testing of an 800 kV PPLP-insulated oil-filled cable and its accessories," in *Proceedings of CIGRE*, Paris, France, 1996.
- [44] A. Fujimori, T. Tanaka, H. Takashima, T. Imajo, R. Hata, T. Tanabe, S. Yoshida, and T. Kakihana, "Development of 500 kV DC PPLP-insulated oil-filled submarine cable," *IEEE Transactions on Power Delivery*, vol. 11, no. 1, pp. 43–50, 1996.
- [45] R. Rendina, A. Gualano, M. Guarniere, G. Paziienza, E. Colombo, S. Malgarotti, F. Bocchi, A. Orini, T. Sturchio, and S. Aleo, "Qualification test program for the 1000 MW-500 kV HVDC very deep water submarine cable interconnection between sardinia island and italian peninsula (SA. PE. I)," in *CIGRE Session*, vol. 42, 2008, pp. 1–8.
- [46] H. Ryosuke, "Solid DC submarine cable insulated with polypropylene laminated paper (PPLP)," *SEI Technical Review*, no. 62, pp. 3–10, 2006.
- [47] E. Houston, "Western HVDC link environmental report, volume 1: Non-technical summary: Marine cable route," 2011.
- [48] M. Jeroense, A. Gustafsson, and M. Bergkvist, "HVDC Light cable system extended to 320 kV," in *CIGRE Session*, B1–304, 2008, pp. 1–9.
- [49] Y. Maekawa, K. Watanabe, S. Maruyama, Y. Murata, and H. Hirota, "Research and development of DC+/–500 kV extruded cables," in *CIGRE Session*, 21–203, 2002, pp. 1–8.
- [50] S. Maruyama, N. Ishii, T. Yamanaka, T. Kimura, and H. Tanaka, "Development of 500 kV DC XLPE cable system and its pre-qualification test," in *A7-2, Jicable*, 2003, p. 232.
- [51] T. Yamanaka, S. Maruyama, and T. Tanaka, "The development of DC+/–500 kV XLPE cable in consideration of the space charge accumulation," in *Proceedings of the 7th International Conference on Properties and Applications of Dielectric Materials*, vol. 2. IEEE, 2003, pp. 689–694.
- [52] M. S. Khalil, "International research and development trends and problems of HVDC cables with polymeric insulation," *IEEE Electrical Insulation Magazine*, vol. 13, no. 6, pp. 35–47, 1997.
- [53] X. Wu, G. Chen, A. Davies, R. Hampton, S. Sutton, and S. Swingler, "Space charge measurements in polymeric HV insulation materials," *IEEE Transactions on Dielectrics and Electrical Insulation*, vol. 8, no. 4, pp. 725–730, 2001.
- [54] A. H. Cookson, "Gas-insulated cables," *IEEE Transactions on Electrical Insulation*, vol. 20, no. 5, pp. 859–890, 1985.
- [55] A. Williams, E. Davey, and J. Gibson, "The +/- 250 kV DC submarine power-cable interconnection," *New Zealand Engineering*, vol. 21, no. 4, p. 145, 1966.
- [56] E. Volpov, "HVDC gas insulated apparatus: electric field specificity and insulation design concept," *IEEE Electrical Insulation Magazine*, vol. 18, no. 2, pp. 7–36, 2002.
- [57] SIEMENS, "Gas-insulated transmission line," Siemens AG, 2012.
- [58] R. Soika, P. Mirebeau, N. Lallouet, E. Marzahn, F. Schmidt, M. Stemmler, and B. West, "HVDC power cables: Potential of superconducting and resistive designs," in *Jicable'11*, C.6.4, Versailles, France, Jun. 2011, pp. 19–23.
- [59] J. McCall, B. Gamble, and S. Eckroad, "Combining superconductor cables and VSC HVDC terminals for long distance transmission," in *2010 IEEE Conference on Innovative Technologies for an Efficient and Reliable Electricity Supply (CITRES)*. IEEE, 2010, pp. 47–54.
- [60] O. Maruyama, T. Okuma, T. Masuda, Y. Ashibe, S. Mukoyama, M. Yagi, T. Saitoh, T. Hasegawa, N. Amemiya, A. Ishiyama *et al.*, "Development of 66 kV and 275 kV class REBCO HTS power cables," *IEEE Transactions on Applied Superconductivity*, vol. 23, no. 3, p. 5401405, 2013.
- [61] L. Xiao, S. Dai, L. Lin, Z. Zhang, and J. Zhang, "HTS power technology for future DC power grid," *IEEE Trans. Appl. Supercond.*, vol. 23, no. 3, p. 5401506, 2013.
- [62] Y. Yin, J. Gu, Q. Wang, Z. Li, and Z. Wang, "Investigation of space charge at the interface between the insulation of cable and its accessory," in *CIGRE Conference, Nice, France*, vol. 32, 1999.
- [63] R. Liu, M. Bergkvist, and M. Jeroense, "Space charge distribution in an extruded cable aged in tap water for 3 years," in *IEEE International Conference on Solid Dielectrics, 2007. ICSD '07*, July 2007, pp. 438–441.
- [64] T. Igi, Y. Murata, K. Abe, M. Sakamaki, S. Kashiyama, and S. Katakai, "Advanced HVDC XLPE cable and accessories," in *9th IET International Conference on Advances in Power System Control, Operation and Management (APSCOM 2012)*, July 2012, pp. 1–6.
- [65] M. Jeroense, M. Saltzer, and H. Ghorbani, "Technical challenges linked to HVDC cable development," *ABB Review*, 2013.
- [66] T. Christen, L. Donzel, and F. Greuter, "Nonlinear resistive electric field grading part 1: theory and simulation," *IEEE Electrical Insulation Magazine*, vol. 26, no. 6, pp. 47–59, 2010.
- [67] L. Donzel, F. Greuter, and T. Christen, "Nonlinear resistive electric field grading part 2: materials and applications," *IEEE Electrical Insulation Magazine*, vol. 27, no. 2, pp. 18–29, 2011.
- [68] S. Boggs, D. H. Damon, J. Hjerrild, J. T. Holboll, and M. Henriksen, "Effect of insulation properties on the field grading of solid dielectric DC cable," *IEEE Transactions on Power Delivery*, vol. 16, no. 4, pp. 456–461, 2001.
- [69] C. Eoll, "Theory of stress distribution in insulation of high-voltage DC cables: part I," *IEEE Transactions on Electrical Insulation*, vol. 10, no. 1, pp. 27–35, 1975.
- [70] C. Eoll, "Theory of stress distribution in insulation of high-voltage DC cables part II," *IEEE Transactions on Electrical Insulation*, vol. 10, no. 2, pp. 49–54, 1975.

- [71] M. Fu, L. A. Dissado, G. Chen, and J. C. Fothergill, "Space charge formation and its modified electric field under applied voltage reversal and temperature gradient in XLPE cable," *IEEE Transactions on Dielectrics and Electrical Insulation*, vol. 15, no. 3, pp. 851–860, 2008.
- [72] W. Choo, G. Chen, and S. Swingler, "Space charge accumulation under effects of temperature gradient and applied voltage reversal on solid dielectric dc cable," in *IEEE 9th International Conference on the Properties and Applications of Dielectric Materials, 2009. ICPADM 2009*. IEEE, 2009, pp. 946–949.
- [73] M. Abou-Dakka, A. Bulinski, and S. Bamji, "Space charge evolution in XLPE with long-term aging under DC voltage—the effect of temperature and polarity reversals," in *2006 IEEE Conference on Electrical Insulation and Dielectric Phenomena*. IEEE, 2006, pp. 537–540.
- [74] Y. Li and T. Takada, "Charge behavior in LDPE at polarity reversal and various DC voltages," in *Proceedings of the 4th International Conference on Conduction and Breakdown in Solid Dielectrics, 1992*. IEEE, 1992, pp. 6–10.
- [75] X. Wu, G. Chen, A. Davies, Y. Tanaka, S. Sutton, and S. Swingler, "Space charge measurements in polyethylene under DC and AC operating conditions using the PEA technique," in *Eighth International Conference on Dielectric Materials, Measurements and Applications, (IEE Conf. Publ. No. 473)*. IET, 2000, pp. 57–62.
- [76] F. Aida, S. Wang, M. Fujita, G. Tanimoto, and Y. Fujiwara, "Study of the mechanism of space charge formation in polyethylene," *Journal of Electrostatics*, vol. 42, no. 1, pp. 3–15, 1997.
- [77] L. Dissado, G. Mazzanti, and G. Montanari, "The role of trapped space charges in the electrical aging of insulating materials," *IEEE Transactions on Dielectrics and Electrical Insulation*, vol. 4, no. 5, pp. 496–506, 1997.
- [78] S. Hwangbo, Y. Kwon, S. Jeon, and M. Han, "Direct correlation between space charge and conduction characteristics of low-density polyethylene at various temperature," *Japanese Journal of Applied Physics*, vol. 37, no. 8R, p. 4419, 1998.
- [79] M. A. Dakka, A. Bulinski, and S. Bamji, "Correlation between space charge development and breakdown in polymeric insulation under dc field," in *Proceedings of the 2004 IEEE International Conference on Solid Dielectrics, 2004. ICSD 2004*, vol. 1. IEEE, 2004, pp. 166–169.
- [80] D. Fabiani, G. Montanari, C. Laurent, G. Teyssedre, P. Morshuis, R. Bodega, L. Dissado, A. Campus, and U. Nilsson, "Polymeric HVDC cable design and space charge accumulation. part 1: Insulation/semicon interface," *IEEE Electrical Insulation Magazine*, vol. 23, no. 6, pp. 11–19, Nov 2007.
- [81] S. Delpino, D. Fabiani, G. Montanari, C. Laurent, G. Teyssedre, P. Morshuis, R. Bodega, and L. Dissado, "Feature article—polymeric HVDC cable design and space charge accumulation. part 2: insulation interfaces," *Electrical Insulation Magazine, IEEE*, vol. 24, no. 1, pp. 14–24, Jan 2008.
- [82] G. C. Montanari, "Bringing an insulation to failure: the role of space charge," *IEEE Transactions on Dielectrics and Electrical Insulation*, vol. 18, no. 2, pp. 339–364, 2011.
- [83] G. Chen and A. Davies, "The influence of defects on the short-term breakdown characteristics and long-term dc performance of LDPE insulation," *IEEE Transactions on Dielectrics and Electrical Insulation*, vol. 7, no. 3, pp. 401–407, 2000.
- [84] R. Fleming, M. Henriksen, and J. Holboll, "The influence of electrodes and conditioning on space charge accumulation in XLPE," *IEEE Transactions on Dielectrics and Electrical Insulation*, vol. 7, no. 4, pp. 561–571, Aug 2000.
- [85] Y. Tanaka, G. Chen, T. Tay, and T. Takada, "Effect of interface on space charge in polyethylene," in *Proceedings of 2001 International Symposium on Electrical Insulating Materials, 2001. (ISEIM 2001)*, 2001, pp. 505–508.
- [86] Y. Chong, G. Chen, and Y. Ho, "Temperature effect on space charge dynamics in XLPE insulation," *IEEE Transactions on Dielectrics and Electrical Insulation*, vol. 14, no. 1, pp. 65–76, 2007.
- [87] G. Chen, M. Brown, A. Davies, C. Rochester, and I. Doble, "Investigation of space charge formation at polymer interface using laser induced pressure pulse technique," in *9th International Symposium on Electrets, 1996. (ISE 9)*, Sep 1996, pp. 285–290.
- [88] L. Dissado, C. Laurent, G. Montanari, and P. Morshuis, "Demonstrating a threshold for trapped space charge accumulation in solid dielectrics under DC field," *IEEE Transactions on Dielectrics and Electrical Insulation*, vol. 12, no. 3, pp. 612–620, June 2005.
- [89] G. Montanari, "The electrical degradation threshold of polyethylene investigated by space charge and conduction current measurements," *IEEE Transactions on Dielectrics and Electrical Insulation*, vol. 7, no. 3, pp. 309–315, Jun 2000.
- [90] J. Auge, C. Laurent, D. Fabiani, and G. Montanari, "Investigating DC polyethylene threshold by space charge. current and electroluminescence measurements," *IEEE Transactions on Dielectrics and Electrical Insulation*, vol. 7, no. 6, pp. 797–803, Dec 2000.
- [91] J. Alison and R. Hill, "A model for bipolar charge transport, trapping and recombination in degassed crosslinked polyethylene," *Journal of Physics D: Applied Physics*, vol. 27, no. 6, pp. 1291–1299, 1994.
- [92] S. Le Roy, P. Segur, G. Teyssedre, and C. Laurent, "Description of bipolar charge transport in polyethylene using a fluid model with a constant mobility: model prediction," *Journal of Physics D: Applied Physics*, vol. 37, no. 2, pp. 298–305, 2004.
- [93] Y. Suzuoki, H. Muto, T. Mizutani, and M. Ieda, "Investigation of space charge in high-density polyethylene using thermal-pulse response," *Japanese Journal of Applied Physics*, vol. 24, no. 5R, pp. 604–609, 1985.
- [94] S. Agnel, P. Notinger, and A. Toureille, "Space charge measurements under applied DC field by the thermal step method," in *2000 Annual Report Conference on Electrical Insulation and Dielectric Phenomena*, vol. 1. IEEE, 2000, pp. 166–170.
- [95] T. Pawlowski, R. Fleming, and S. Lang, "Limm study of space charge in crosslinked polyethylene," *IEEE Transactions on Dielectrics and Electrical Insulation*, vol. 13, no. 5, pp. 1023–1029, 2006.
- [96] A. Tanaka, M. Maeda, and T. Takada, "Observation of charge behavior in organic photoconductor using pressure-wave propagation method," *IEEE Transactions on Electrical Insulation*, vol. 27, no. 3, pp. 440–444, Jun 1992.
- [97] D. Malec, "Technical problems encountered with the laser induced pressure pulse method in studies of high voltage cable insulators," *Measurement Science and Technology*, vol. 11, no. 5, pp. 76–80, 2000.
- [98] T. Maeno, H. Kushibe, T. Takada, and C. Cooke, "Pulsed electroacoustic method for the measurement of volume charges in E-beam irradiated PMMA," *CEIDP Annual Report*, pp. 389–393, 1985.
- [99] R. Liu, T. Takada, and N. Takasu, "Pulsed electro-acoustic method for measurement of space charge distribution in power cables under both DC and AC electric fields," *Journal of Physics D: Applied Physics*, vol. 26, no. 6, pp. 986–993, 1993.
- [100] T. Takeda, N. Hozumi, H. Suzuki, K. Fujii, K. Terashima, M. Hara, Y. Mutrata, K. Wantanabe, and M. Yoshida, "Space charge behavior in full-size 250 kV DC XLPE cables," *IEEE Transactions on Power Delivery*, vol. 13, no. 1, pp. 28–39, 1998.
- [101] F. Lim, R. Fleming, and R. Naybour, "Space charge accumulation in power cable XLPE insulation," *IEEE Transactions on Dielectrics and Electrical Insulation*, vol. 6, no. 3, pp. 273–281, 1999.
- [102] M. Fu, G. Chen, A. E. Davies, Y. Tanaka, and T. Takada, "A modified PEA space charge measuring system for power cables," in *Proceedings of the 6th International Conference on Properties and Applications of Dielectric Materials*, vol. 1 & 2, 2000, pp. 104–107.
- [103] M. Fu and G. Chen, "Space charge measurement in polymer insulated power cables using flat ground electrode PEA system," *IEE Proceedings—Science, Measurement and Technology*, vol. 150, no. 2, pp. 89–96, 2003.
- [104] U. Nilsson and J. O. Boström, "Influence of the semiconductor material on space charge build-up in extruded HVDC cables," in *Conference Record of the 2010 IEEE International Symposium on Electrical Insulation (ISEI)*. IEEE, 2010, pp. 1–4.
- [105] B. Xi and G. Chen, "The mechanism of electrical conduction in polyethylene/carbon black composite," in *Proceedings of the 6th International Conference on Properties and Applications of Dielectric Materials*, vol. 2. IEEE, 2000, pp. 1015–1018.
- [106] Y. Ho, G. Chen, A. Davies, R. Hampton, S. Swingler, and S. Sutton, "Do semicons affect space charge?" in *Proceedings of the 2001 IEEE 7th International Conference on Solid Dielectrics*. IEEE, 2001, pp. 105–108.
- [107] Z. An, Q. Yang, C. Xie, Y. Jiang, F. Zheng, and Y. Zhang, "Suppression effect of surface fluorination on charge injection into linear low density polyethylene," *Journal of Applied Physics*, vol. 105, no. 6, p. 064102, 2009.
- [108] Y. Zhang, F. Zheng, Z. An, and X. Zhang, "Research on space charge in insulating and functional dielectrics at Tongji University," *IEEE Electrical Insulation Magazine*, vol. 28, no. 3, pp. 14–25, 2012.
- [109] G. Cartwright, A. Davies, S. Swingler, and A. Vaughan, "Effect of an antioxidant additive on morphology and space-charge characteristics of low-density polyethylene," *IEE Proceedings—Science, Measurement and Technology*, vol. 143, no. 1, pp. 26–34, 1996.
- [110] T. Mizuno, T. Takahashi, H. Harada, N. Hayashi, Y. Tanaka, and T. Maeno, "Effect of conductive inorganic filler on space charge charac-

- teristics in XLPE as a HVDC insulating material,” in *8th International Conference on Insulated Power, Paper C*, vol. 5, 2011, pp. 19–23.
- [111] Y. Cao, P. C. Irwin, and K. Younsi, “The future of nanodielectrics in the electrical power industry,” *IEEE Transactions on Dielectrics and Electrical Insulation*, vol. 11, no. 5, pp. 797–807, 2004.
- [112] Y. Murata and M. Kanaoka, “Development history of HVDC extruded cable with nanocomposite material,” in *8th International Conference on Properties and applications of Dielectric Materials*. IEEE, 2006, pp. 460–463.
- [113] G. Chen, C. Zhang, and G. Stevens, “Space charge in LLDPE loaded with nanoparticles,” in *Annual Report-Conference on Electrical Insulation and Dielectric Phenomena*. IEEE, 2007, pp. 275–278.
- [114] J. W. Zha, Z. M. Dang, H. T. Song, Y. Yin, and G. Chen, “Dielectric properties and effect of electrical aging on space charge accumulation in polyimide/TiO₂ nanocomposite films,” *Journal of Applied Physics*, vol. 108, no. 9, pp. 094113–094113, 2010.
- [115] Y. Murata, M. Sakamaki, K. Abe, Y. Inoue, S. Mashio, S. Kashiyama, O. Matsunaga, T. Igi, M. Watanabe, S. Asai *et al.*, “Development of high voltage DC-XLPE cable system,” *SEI Technical Review*, no. 76, pp. 55–62, 2013.
- [116] S. Maruyama, N. Ishii, M. Shimada, S. Kojima, H. Tanaka, M. Asano, T. Yamanaka, and S. Kawakami, “Development of a 500-kV DC XLPE cable system,” *Furukawa Review*, vol. 25, pp. 47–52, 2004.
- [117] G. Chen and M. Kamaruzzaman, “Impact of mechanical deformation on space charge in XLPE,” in *IEEE International Conference on Solid Dielectrics, 2007. ICSD’07*. IEEE, 2007, pp. 510–513.
- [118] N. Hussin and G. Chen, “Space charge accumulation and conductivity of crosslinking byproducts soaked LDPE,” in *2010 Annual Report Conference on Electrical Insulation and Dielectric Phenomena (CEIDP)*. IEEE, 2010, pp. 1–4.
- [119] A. Campus, P. Carstensen, A. Farkas, and M. Meunier, “Chemical defects and electron trapping relevant to cable dielectrics,” in *2002 Annual Report Conference on Electrical Insulation and Dielectric Phenomena*. IEEE, 2002, pp. 155–158.
- [120] M. Meunier, N. Quirke, and A. Aslanides, “Molecular modeling of electron traps in polymer insulators: Chemical defects and impurities,” *The Journal of Chemical Physics*, vol. 115, no. 6, pp. 2876–2881, 2001.
- [121] N. Hampton, R. Hartlein, H. Lennartsson, H. Orton, and R. Ramachandran, “Long-life XLPE insulated power cable,” in *Jicable’07*. Georgia Institute of Technology, C5.1.5, 2007.
- [122] A. Farkas, C. Olsson, G. Dominguez, V. Englund, P. Hagstrand, and U. Nilsson, “Development of high performance polymeric materials for HVDC cables,” in *Jicable’11*, vol. 2, A2.5, Versailles, France, Jun. 2011, pp. 19–23.
- [123] T. Hjertberg, V. Englund, P. O. Hagstrand, W. Loyens, U. Nilsson, and A. Smedberg, “Materials for HVDC cables,” *REE. Revue de l’électricité et de l’électronique*, no. 4, 2014.

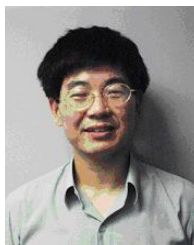

George Chen (SM’11) was born in China in 1961. He received the B.Eng. (1983) and M.Sc. (1986) degrees in electrical engineering from Xi’an Jiaotong University, China. After he obtained the Ph.D. degree (1990) from the University of Strathclyde, UK, on the work of permanent changes in electrical properties of irradiated low-density polyethylene, he joined the University of Southampton as Postdoctoral Research Fellow and became a Senior Research Fellow subsequently. In 1997 he was appointed as a Research Lecturer and promoted to a Reader in 2002. He is now a Professor of high voltage engineering at the University of Southampton and a Visiting Professor of Xi’an Jiaotong University. Over the years, he has developed a wide range of interests in high voltage engineering and electrical properties of materials and published over 300 papers. He is active in the HVDC systems and involved with technical working groups in both IEEE and CIGRE.



Miao Hao was born in China in 1987. He received his B.Eng. degree (2009) from Xi’an Jiaotong University, China and M.Sc. degree (2011) both in electrical engineering from University of Southampton, UK. Since 2011, he has been a Ph.D. student in the University of Southampton, U.K. His main research interests include space charge and ageing mechanism in the oil impregnated pressboard insulation system for HVDC converter transformer.



cables.

Zhiqiang Xu was born in Liaoning, China, in 1977. She received the M.Sc. (2004) degree in automation of electric power system from the Northeast Electric Power University, China, and worked in the State Grid Corporation of China (SGCC) from 2004–2005. She received the Ph.D. degree in electrical engineering from University of Southampton in 2009. She has been a Research Fellow in the School of Electronics and Computer Science at the University of Southampton since 2009. Her research interests are in space charge, insulation materials and HVDC



Alun Vaughan has a B.Sc. degree in Chemical Physics and a Ph.D. degree in polymer physics. After working at the U.K.’s Central Electricity Research Laboratories and spending a period as an academic at The University of Reading, he is now Professor in electronics and computer science at the University of Southampton. He is an EPSRC College member, Honorary Treasurer of The Dielectrics Group of the Institute of Physics, a Fellow of the Institute of Physics, Senior Member of the IEEE and a Fellow of the IET.



Junzheng Cao received his B.S. and M.S. degrees from Xi’an Jiaotong University, Xi’an, China, in 1982 and 1985, respectively, and his Ph.D. degree from the London South Bank University, London, England, U.K., in 1997. Prior to returning China in 2010, he served as a principal engineer and an HVDC expert at AREVA/ALSTOM T&D. He is presently a Professor-level Senior Engineer and Chief Engineer in the HVDC Department of the State Grid Smart Grid Research Institute (SGRI), Beijing, China, a sub-organization of the State Grid Corporation of China (SGCC), Beijing, China. He was made China’s National Distinguished Expert of the “1000-Elite Program,” in 2010, and a Guest Professor of Xi’an Jiaotong University in 2012. He has authored or co-authored over 30 HVDC related technical papers, holds 17 patents and has written a book, *China Electric Power Encyclopedia*. Dr. Cao is a member of IEEE, IET, Cigre and several working groups, including the Cigre working group B4-62, IEC TC22/22F/MT10, IEC TC22/22F/WG26, and the National Technical Committee 60 on Power Electronics of the Standardization Administration of China (SAC/TC60/SC2). He is a paper reviewer for the IEEE Transactions on Smart Grid and the IEEE Transactions on Instrumentation and Measurement. His current research interests include the development and engineering of high voltage equipment for FACTS, HVDC, and future DC grid applications.



Haitian Wang was born in Hunan, China. He received the B.Sc. degree in computation mathematics and M. Eng. degree in electrical engineering, from Sichuan University, Chengdu, China, in 1999, 2003, respectively, and the Ph.D. degree in electrical engineering from Shanghai Jiao Tong University, Shanghai, China, in 2011. During 2011–2013, he held a Postdoctoral position with China Electric Power Research Institute (CEPRI), Beijing, China. He was sponsored by China Postdoctoral Science Foundation. In 2013, he joined the State Grid Smart Grid Research Institute, Beijing. His research fields include the voltage source converter based high voltage DC (VSC-HVDC) transmission systems, and cross-linked polyethylene cable for VSC-HVDC transmission systems. He is the author and coauthor of more than 20 scientific papers and, so far, has 5 papers that have been published in IEEE transactions. He is a paper reviewer for the IEEE Transactions on Industry Applications and the IEEE Industry Applications Magazine.