

Algorithm for the Optimal Design of a Fault-Tolerant Aircraft Power Transmission Network

Marta Zárraga-Rodríguez¹, Xavier Insausti¹, Fermín Rodríguez Lalanne¹, Javier Velasco,
and Jesús Gutiérrez-Gutiérrez², *Senior Member, IEEE*

Abstract—Aircraft manufacturers aim to decrease the fuel consumption based on reducing weight and increasing the subsystem efficiency. Hence, the electric power system (EPS) acquires great relevance because it must be efficient and lightweight. Any change in the EPS must not affect the aircraft's electrical safety, which under a traditional decentralized EPS strategy is ensured by redundancy. Recently, several decentralized EPS strategies based on the introduction of multiport power converters have arisen. Such strategies meet the established safety goals since the aforementioned devices make it possible to recalculate the path to continue powering the loads in case of failure. However, the literature does not address how to connect such multiport power converters. The main contribution of this article is to present a low-complexity algorithm that minimizing the redundancy of wiring, provides a fault-tolerant power transmission network. This is done under a decentralized EPS strategy where multiport power converters are used. The proposed strategy is evaluated on Boeing 787 aircraft, where we compare the length of the cables both under a traditional decentralized network configuration (where the redundancy option is used to ensure the safety of operation) and in the network provided by our algorithm. A saving of 66.6% is obtained.

Index Terms—Aircraft power systems, network fault tolerance.

I. INTRODUCTION

IN TRADITIONAL aircraft models, some of the basic devices installed in the fuselage required the combination of hydraulic, mechanical, and pneumatic systems to operate. Those systems were heavy, oversized, and inefficient. Furthermore, they usually produced leaks that were difficult to locate and they required ongoing maintenance [1], [2]. Thus, in the late 1950s, aircraft manufacturers started analyzing as a feasible choice the replacement of nonelectrical systems by electric ones based on their higher efficiency and lower

maintenance, and along the 1970s decade, the more electric aircraft (MEA) concept was coined [3], [4].

Several approaches to the MEA concept have been adopted to increase aircraft's whole efficiency based on a reduction of aircraft's weight [5]–[8]. These approaches affect the aircraft's electric power system (EPS), and some new challenges need to be addressed [9], [10], i.e., power generation, power transmission network (EPS architecture), power electronics, or systems' safety of operation (fault-tolerant EPS). In this article, we focus on the power transmission network and the systems' safety of operation. The power transmission network transfers the energy from the engines to the workloads and the safety of operation is traditionally based on the redundancy strategy.

On the one hand, the power transmission network must be efficient and lightweight so that fuel consumption can be reduced. The reduction of weight is critical and one of the most important factors that affects the total weight of the aircraft's EPS is precisely the wiring system [11]. A relevant milestone was achieved with a multivoltage hybrid dc and ac EPS architecture that employs four different voltage levels: 230 V and 115 V in the ac power system and (\pm)270 V and (\pm)28 V in the dc power system [12], [13]. Through this proposed EPS architecture, lower currents were necessary, and consequently, the power losses through transmission were reduced and aircraft becomes lighter because smaller conductors were used [8], [10]. In conventional centralized EPS architecture, all the electrical wiring is distributed from the main bus to different loads. This centralized EPS architecture has been replaced with a semidistributed (decentralized) architecture, where a large number of power distribution units (PDUs) are located throughout the aircraft to supply the loads locally. This architecture reduces wiring and saves weight (see, e.g., [2], [5], [14]). For instance, for a large civil aircraft with high demand on the electrical network, about 46% of the electrical wiring serves to distribute electrical power from the power centers to the loads and adds up to about 2.6 tons [15], which offers potential for optimization.

On the other hand, to guarantee the safety of operation, high redundancy of wiring and critical devices is needed. It is obvious that this redundancy increases the aircraft's weight. Hence, weight reduction and safety seem to disagree with each other.

Manuscript received 2 March 2022; revised 10 May 2022; accepted 3 July 2022. Date of publication 7 July 2022; date of current version 21 October 2022. This work was supported in part by the Basque Government through the CODISAVA2 Project under Grant KK-2020/00044. (Corresponding author: *Xabier Insausti*.)

Marta Zárraga-Rodríguez, Xavier Insausti, and Jesús Gutiérrez-Gutiérrez are with Tecnun, University of Navarra, 20018 San Sebastián, Spain (e-mail: mzarraga@tecnun.es; xinsausti@tecnun.es; jgutierrez@tecnun.es).

Fermín Rodríguez Lalanne is with the Centro de Estudios e Investigaciones Técnicas (CEIT), Basque Research and Technology Alliance (BRTA), 20018 San Sebastián, Spain, and also with TECNALIA Research and Innovation, 48160 Derio, Spain (fermin.rodriguez@tecnalia.com).

Javier Velasco is with Fundación CTA, 01510 Miñano, Spain (e-mail: javier.velasco@cta.aero).

Digital Object Identifier 10.1109/TTE.2022.3189442

During the last years, milestones established by organisms such as Advisory Council for Aeronautics Research in Europe (ACARE) and the Flightpath European Commission (FPC) show that even further improvements in terms of aircraft's efficiency and safety are required [16]–[20]. According to this, current MEA's studies are cataloged into two main groups. The first group focuses on developing novel software for increasing aircraft's efficiency [21], [22]. The second group focuses on new feasible architectures to increase aircraft's efficiency and safety of operation [23], [24].

Concerning to the group that examines novel architectures, Garriga *et al.* [23] proposed a novel algorithm, which selects between several feasible EPS structures the optimal one for a defined aircraft model. To make this choice, the proposed algorithm iteratively balances a certain number of parameters such as new aircraft model's global weight or fuel consumption until the optimal solution is fixed. Moreover, Jia and Rajashekara [24] analyzed the advantages of designing novel aircraft's distributed EPS architectures, such as the introduction of induction generators to improve the EPS's availability and reliability.

Concerning to the methodology for designing aircraft, Sziroczak *et al.* [25] claimed that the performance in future MEAs efficiency only will be achieved by redesigning both the propulsion system and the EPS. They developed a conceptual methodology where the propulsion system of a small aircraft is driven by a hybrid-electric propulsion system. The main contributions obtained with this study rely on the introduction of the recalibration of mass fractions in novel configurations as well as the hybrid-electric propulsion system.

In their study, Alexander *et al.* [26] made an analysis of different vehicles' EPSs and their evolution in the last years, to make a prediction about future MEAs architectures characteristics such as feasible voltage levels or equipment ratings. The research concludes that few key factors, such as energy density, weight, propulsion systems, and EPSs' architectures, will be the main bottlenecks to achieve the goals stated to the MEA. In addition, the authors claimed that recent results obtained with lithium–air batteries and novel small-scale full-electric aircraft makes possible the research on novel further electrified large-scale aircraft with novel architectures.

Gu *et al.* [27] made research on the traditional redundancy strategy, which involves increasing aircraft's weight. In order to meet FPC goals, Gu *et al.* [27] examined several EPS strategies based on the introduction of multiport power converters to meet established safety goals without increasing aircraft's weight. Thus, Gu *et al.* [27] concluded that multiport devices combined with a ring EPS strategy achieve the best results. Following the strategy proposed in [27], Rodríguez *et al.* [28] and Martínez *et al.* [29] presented a novel multiport hardware device that makes possible to recalculate the optimal path to continue powering the loads in the case of failure occurring in the aircraft's EPS network.

As well as it is proposed in [27] and [28], Buticchi *et al.* [30] presented a multiport quadruple active bridge (QAB) dc/dc converter to show how the architecture of the MEA can be modified. The topology proposed in [30] is traditionally applied in those EPSs where the

devices connected it need to ensure flexibility and galvanic isolation.

Nevertheless, current partial decentralized EPS or aircraft's EPS architectures proposed by the Clean Sky 2 framework [31] as well as strategies proposed by Gu *et al.* [27] and Rodríguez *et al.* [28] did not address how to make an optimal connection between the developed multiport devices.

In this article, we aim to improve the aircraft's efficiency by reducing its weight while guaranteeing the safety of operation. Specifically, under a decentralized EPS strategy, we propose to minimize the redundancy of wiring. To that end, we will design a power transmission network where enough different routes are guaranteed to power the loads and with the lowest number of internal connections (cables). Once the network is established, software and hardware modifications proposed in [28] and [29] will guarantee that all connections work properly since it will recalculate the optimal path to continue powering the loads if there is a failure in the aircraft's EPS network.

The aircraft's EPS network under a decentralized strategy can be viewed as an undirected connected multigraph. There exist a variety of techniques for connecting the nodes of a graph under certain conditions. The problem addressed in this article is similar to the well-known Steiner problem in networks, which is NP-complete. This problem looks for an optimal interconnection of a given set of nodes under a certain cost function. Hakimi [32] and Levin [33] formulated this problem for the first time, but many other variants exist (see [34]). It should be mentioned that the problem considered in this article cannot be addressed neither as a Steiner problem in graphs nor as any of its variants mainly because of two reasons: in our problem, multiple connections (cables) between devices (nodes) are allowed, and not all the possible interconnections between devices are permitted (e.g., a load cannot feed other devices).

Thus, the main contribution of this article is to provide an algorithm for the optimal design of a fault-tolerant aircraft's power transmission network under a decentralized EPS strategy. Furthermore, as it was mentioned above, when designing an EPS network, goals as weight reduction and safety seem to disagree with each other. The novelty of this article is that we show that using our algorithms, it is possible to save wiring while guaranteeing the safety of operation.

The remainder of this article is organized as follows. In Section II, we state preliminary considerations regarding undirected connected multigraphs and present a technical proposition that will be used in Section III. In Section III, we present the optimal interconnection problem to be solved in order to guarantee a sufficient number of different routes to power the loads with the lowest number of cables. In Section IV, we propose two algorithms that solve, with low complexity, the minimization problem in Section III. Finally, in Sections V and VI, we give an illustrative example and some conclusions, respectively.

II. PRELIMINARIES

Aircraft's EPS network can be viewed as an undirected connected multigraph $G = (\mathcal{V}(G), \mathcal{E}(G))$ with no loops,

where $\mathcal{V}(G)$ is the set of vertices (devices) and $\mathcal{E}(G)$ is the set of edges (cables). We recall that a multigraph with no loops is a graph where multiple edges joining the same two vertices are allowed (see, e.g., [35, p. 7]).

If G_1 and G_2 are two subgraphs of G , the union of G_1 and G_2 is the subgraph of G of the form

$$G_1 \cup G_2 = (\mathcal{V}(G_1) \cup \mathcal{V}(G_2), \mathcal{E}(G_1) \cup \mathcal{E}(G_2)).$$

Let v_0 and v_l be two distinct vertices of G . A path between v_0 and v_l is a subgraph $P = (\mathcal{V}(P), \mathcal{E}(P))$ where

$$\begin{aligned} \mathcal{V}(P) &= \{v_0, v_1, \dots, v_l\} \subseteq \mathcal{V}(G) \\ \mathcal{E}(P) &= \{e_1, e_2, \dots, e_l\} \subseteq \mathcal{E}(G) \end{aligned}$$

and e_j is an edge from v_{j-1} to v_j for all $j \in \{1, 2, \dots, l\}$. Assume that P_1, P_2, \dots, P_h are different paths between v_0 and v_l . These paths are said to be edge-disjoint if they have no edges in common, that is, $\mathcal{E}(P_i) \cap \mathcal{E}(P_j) = \emptyset$ for all $i \neq j$ (see, e.g., [36, p. 47]). The maximum number of different edge-disjoint paths between v_0 and v_l is denoted by $\lambda_G(v_0, v_l)$ (obviously, $\lambda_G(v_0, v_l) = \lambda_G(v_l, v_0)$).

We finish this section with a technical proposition that will be used in Section III.

Proposition 1: Let G_1 and G_2 be two subgraphs of an undirected connected multigraph G with no loops such that $G_1 \cup G_2 = G$ and $\mathcal{V}(G_1) \cap \mathcal{V}(G_2) = \{v^*\}$. Then,

$$\lambda_G(v_1, v_2) = \min\{\lambda_{G_1}(v_1, v^*), \lambda_{G_2}(v^*, v_2)\} \quad (1)$$

for all $v_1 \in \mathcal{V}(G_1) \setminus v^*$ and $v_2 \in \mathcal{V}(G_2) \setminus v^*$.

Proof: Let $v_1 \in \mathcal{V}(G_1) \setminus \{v^*\}$ and $v_2 \in \mathcal{V}(G_2) \setminus \{v^*\}$. We denote $\lambda_{G_1}(v_1, v^*)$ and $\lambda_{G_2}(v_2, v^*)$ by λ_1 and λ_2 , respectively. We divide the proof into seven steps.

Step 1: We prove that $\mathcal{E}(G_1) \cap \mathcal{E}(G_2) = \emptyset$. We prove it by *reductio ad absurdum*. Suppose that $l \in \mathcal{E}(G_1) \cap \mathcal{E}(G_2)$ joins vertices q and r . Then, $q, r \in \mathcal{V}(G_1) \cap \mathcal{V}(G_2)$. Since $\mathcal{V}(G_1) \cap \mathcal{V}(G_2) = \{v^*\}$, $q = r = v^*$, and therefore, l is a loop (which is absurd since G has no loops).

Step 2: We prove that if $l \in \mathcal{E}(G)$ joins v_1 , then $l \in \mathcal{E}(G_1)$ (analogously, it can be proved that if $l \in \mathcal{E}(G)$ joins v_2 , then $l \in \mathcal{E}(G_2)$). We prove it by *reductio ad absurdum*. Suppose that $l \in \mathcal{E}(G_2)$. Hence $v_1 \in \mathcal{V}(G_2)$. Consequently $v_1 \in \mathcal{V}(G_1) \cap \mathcal{V}(G_2) = \{v^*\}$ (which is absurd since $v_1 \neq v^*$).

Step 3: We show that every path between v_i and v^* is a subgraph of G_i , with $i \in \{1, 2\}$. This is a direct consequence of Step 2.

Step 4: We show that $\lambda_G(v_i, v^*) = \lambda_i$, with $i \in \{1, 2\}$. This is a direct consequence of Step 3.

Step 5: We prove that $\lambda_G(v_1, v_2) \geq \min\{\lambda_1, \lambda_2\}$. Let $Q_1, \dots, Q_{\lambda_1}$ be edge-disjoint paths between v_1 and v^* and $R_1, \dots, R_{\lambda_2}$ be edge-disjoint paths between v_2 and v^* . We have

$$\{v^*\} \subseteq \mathcal{V}(Q_i) \cap \mathcal{V}(R_j) \subseteq \mathcal{V}(G_1) \cap \mathcal{V}(G_2) = \{v^*\}$$

for all $i \in \{1, \dots, \lambda_1\}$ and $j \in \{1, \dots, \lambda_2\}$. From Step 1, we obtain

$$\emptyset \subseteq \mathcal{E}(Q_i) \cap \mathcal{E}(R_j) \subseteq \mathcal{E}(G_1) \cap \mathcal{E}(G_2) = \emptyset$$

for all $i \in \{1, \dots, \lambda_1\}$ and $j \in \{1, \dots, \lambda_2\}$. Hence, $P_j = Q_j \cup R_j$ with $j \in \{1, \dots, \min\{\lambda_1, \lambda_2\}\}$ is a path between v_1 and v_2 . Since

$$\begin{aligned} \mathcal{E}(P_i) \cap \mathcal{E}(P_j) &= (\mathcal{E}(Q_i) \cup \mathcal{E}(R_i)) \cap (\mathcal{E}(Q_j) \cup \mathcal{E}(R_j)) \\ &= ((\mathcal{E}(Q_i) \cup \mathcal{E}(R_i)) \cap \mathcal{E}(Q_j)) \\ &\quad \cup ((\mathcal{E}(Q_i) \cup \mathcal{E}(R_i)) \cap \mathcal{E}(R_j)) \\ &= (\mathcal{E}(Q_i) \cap \mathcal{E}(Q_j)) \cup (\mathcal{E}(R_i) \cap \mathcal{E}(Q_j)) \\ &\quad \cup (\mathcal{E}(Q_i) \cap \mathcal{E}(R_j)) \cup (\mathcal{E}(R_i) \\ &\quad \cap \mathcal{E}(R_j)) = \emptyset \end{aligned}$$

for all $i \neq j$ with $i, j \in \{1, \dots, \min\{\lambda_1, \lambda_2\}\}$, the paths $P_1, \dots, P_{\min\{\lambda_1, \lambda_2\}}$ are edge-disjoint paths between v_1 and v_2 .

Step 6: We prove that if P is a path between v_1 and v_2 then $v^* \in \mathcal{V}(P)$. We prove it by *reductio ad absurdum*. Suppose that $v^* \notin \mathcal{V}(P)$. By induction, we can prove, using Step 2, that $\mathcal{E}(P) \subseteq \mathcal{E}(G_1)$. Analogously, it can be proved that $\mathcal{E}(P) \subseteq \mathcal{E}(G_2)$ (which is absurd since $\mathcal{E}(G_1) \cap \mathcal{E}(G_2) = \emptyset$).

Step 7: We prove that $\lambda_G(v_1, v_2) \leq \min\{\lambda_1, \lambda_2\}$. From Steps 4 and 6, we conclude that $\lambda_G(v_1, v_2) \leq \lambda_G(v_i, v^*) = \lambda_i$, for all $i \in \{1, 2\}$. ■

III. PROBLEM STATEMENT

We aim to design a fault-tolerant aircraft's power transmission network under a decentralized EPS strategy with the minimum number of cables. We consider a multivoltage hybrid dc and ac EPS architecture that employs four different voltage levels (230 V and 115 V in the ac power system and $(\pm)270$ V and $(\pm)28$ V in the dc power system). The considered decentralized EPS architecture has a high-voltage primary power center (HVPPC) that powers the high-voltage (HV) power system and a low-voltage primary power center (LVPPC) that powers the low-voltage (LV) system. The HVPPC powers the ac loads of 230 V and, by using power electronics, the dc loads of 270 V. The LVPPC powers the ac loads of 115 V and, by using power electronics, the dc loads of 28 V. Under a decentralized EPS architecture, a large number of PDUs fed from the power centers are located throughout the aircraft to supply loads locally. We here consider that the PDUs can feed the four different voltage levels or even provide power to other PDUs. Since there are four different voltage levels, there are four different subnetworks to be designed where interconnections among PDUs are allowed. Fig. 1 shows the considered EPS architecture.

Aircraft's power transmission network fault tolerance is traditionally based on the redundancy of internal connections and critical devices. In this way, the feeding of the loads during the operation phase is guaranteed but at the cost of increased weight. The number of different routes needed to feed a load is chosen by the aircraft designer¹ and depend on each load's priority level. In this article, the priority of a load is defined as the number of different routes (edge-disjoint paths) from the power center to such load. Under a traditional decentralized

¹It should be mentioned that aircraft designer has to set other restrictions regarding distances, weight distribution, inertia coupling, electromagnetic interferences, and so on. These restrictions affect the design of the EPS architecture, but they are outside the scope of this article.

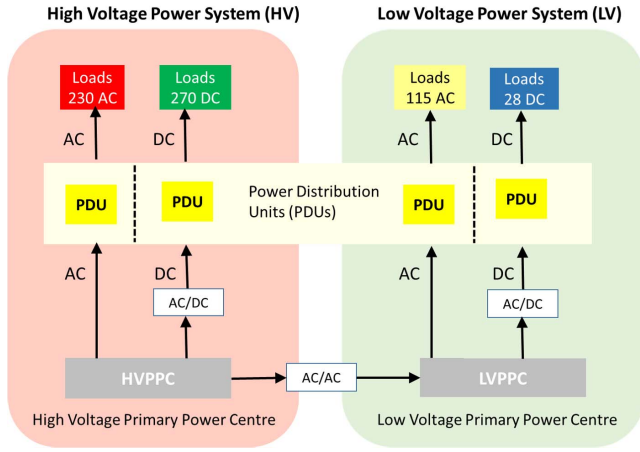

Fig. 1. Considered power transmission network.

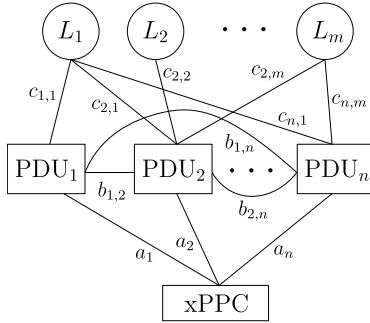

Fig. 2. Considered power transmission subnetwork.

EPS strategy, a PDU can feed several loads, but each load is fed by a single PDU. Therefore, the number of cables from the power center to a PDU is given by the highest of the priorities of the loads fed by such PDU. The higher priority the loads have, the higher the redundancy of internal connections, and therefore, the weight of the whole aircraft is increased as well as fuel consumption.

We aim to design an aircraft power transmission network that guarantees the number of different routes needed to keep each load's priority level with the minimum number of cables avoiding the redundancy option. To that end, the considered PDUs are also provided with software and hardware modifications proposed in [28] and [29]. Such modifications allow PDUs to be fed by other PDUs, allow loads to be fed by several PDUs, and make it possible to recalculate the optimal route to continue powering the loads in the case of failure. It should be mentioned that although the fault-tolerant algorithm developed in [28] works for every voltage level, the hardware for the power distribution of each voltage level will be different.

Without loss of generality, in this section, we state the design problem for one of the four mentioned subnetworks (the problem statement for the other subnetworks is analogous). Fig. 2 shows the considered subnetwork with a primary power center (xPPC), n PDUs (PDU_1, \dots, PDU_n), m loads (L_1, \dots, L_m), and the internal connections among them. In the figure, a_i represents the number of cables between the xPPC and PDU_i , $b_{i,j}$ represents the number of cables between PDU_i and PDU_j , and $c_{i,k}$ represents the number of cables between

PDU_i and L_k , where $i, j \in \{1, \dots, n\}$ and $k \in \{1, \dots, m\}$. Finally, p_k represents the priority of L_k . Observe that the subnetwork in Fig. 2 can be viewed as an undirected connected multigraph G with no loops. We denote by G_k the subgraph of G obtained by removing in G all the loads except for L_k (it is obvious that all the edges connected to the removed loads are also removed).

In order to guarantee the number of different routes needed to keep each load's priority level with the minimum number of cables, we need to solve the following minimization problem:

$$\begin{aligned} & \text{minimize} && \sum_{i=1}^n \left(a_i + \sum_{j=i+1}^n b_{i,j} + \sum_{k=1}^m c_{i,k} \right) \\ & \text{subject to} && \lambda_{G_k}(L_k, \text{xPPC}) \geq p_k, \quad \forall k \in \{1, \dots, m\} \quad (2) \end{aligned}$$

where $a_i, b_{i,j}, c_{i,k} \in \{0, 1, 2, \dots\}$ for all $i, j \in \{1, \dots, n\}$ and $k \in \{1, \dots, m\}$.

Observe that the complexity of the minimization problem (2) grows exponentially with the number of devices (n and m). For large values of n and m , exhaustive search becomes intractable because of the size of the search space. To handle the minimization problem (2), we exploit the fact that devices are physically located in different zones of the airplane.

Let q be the number of zones in the airplane and $\{\mathcal{D}_z\}_{z=1}^q$ be a partition of the set $\{1, \dots, n\}$ such that, if $i \in \mathcal{D}_z$, PDU_i is located in zone z . Similarly, let $\{\mathcal{L}_z\}_{z=1}^q$ be a partition of the set $\{1, \dots, m\}$ such that, if $k \in \mathcal{L}_z$, load L_k is located in zone z .

Now, we address the minimization problem (2) by reducing the search space according to the following assumptions.

- 1) In each zone z , we select a central PDU denoted by PDU_{d_z} . Only these central PDUs can be directly powered by the xPPC. Therefore, some a_i will be forced to be zero. Specifically, $a_i = 0$ whenever $i \neq d_z$ for all $z \in \{1, \dots, q\}$.
- 2) If two PDUs are located in different zones, they cannot be connected unless they are both central PDUs. Therefore, some $b_{i,j}$ will be forced to be zero. Specifically, $b_{i,j} = 0$ whenever $i \in \mathcal{D}_{z_1} \setminus \{d_{z_1}\}$ and $j \in \mathcal{D}_{z_2} \setminus \{d_{z_2}\}$ with $z_1 \neq z_2$.
- 3) The loads in an specific zone can only be powered by PDUs located in the same zone. Therefore, some $c_{i,k}$ will be forced to be zero. Specifically, $c_{i,k} = 0$ whenever $i \in \mathcal{D}_{z_1}$ and $k \in \mathcal{L}_{z_2}$ with $z_1 \neq z_2$.
- 4) All the available PDUs located in zone z must be used to power the loads. Therefore, $\sum_{k \in \mathcal{L}_z} c_{i,k} \geq 1$ for all $i \in \mathcal{D}_z$.

Consequently, the minimization problem (2) can be rewritten as

$$\begin{aligned} & \text{minimize} && \sum_{z=1}^q \left(a_{d_z} + \sum_{z'=z+1}^q b_{d_z, d_{z'}} + \sum_{\substack{i,j \in \mathcal{D}_z \\ i > j}} b_{i,j} + \sum_{\substack{i \in \mathcal{D}_z \\ k \in \mathcal{L}_z}} c_{i,k} \right) \\ & \text{subject to} && \lambda_{G_k}(L_k, \text{xPPC}) \geq p_k, \quad \forall k \in \mathcal{L}_z, \quad \forall z \in \{1, \dots, q\} \\ & && \sum_{k \in \mathcal{L}_z} c_{i,k} \geq 1 \quad \forall i \in \mathcal{D}_z, \quad \forall z \in \{1, \dots, q\}. \quad (3) \end{aligned}$$

Despite the assumptions made, the complexity of the minimization problem (3) is still very high making exhaustive search intractable. However, we can now use the divide-and-conquer technique and divide the minimization problem (3) into $q + 1$ subproblems of the same type with much lower complexity. To that end, we first need to introduce some notation.

Fix $z \in \{1, \dots, q\}$ and $k \in \mathcal{L}_z$. Let H_k and \overline{H}_z be two subgraphs of G_k . The subgraph H_k represents the power transmission network in the zone z , that is, the vertices of H_k represent the PDUs $\{\text{PDU}_i\}_{i \in \mathcal{D}_z}$ together with the load L_k , and the edges of H_k represent the connections among them. The subgraph \overline{H}_z represents G_k except for the power transmission network in the zone z but including PDU_{d_z} , i.e.,

$$\begin{aligned}\mathcal{V}(\overline{H}_z) &= \mathcal{V}(G_k) \setminus \mathcal{V}(H_k) \cup \{\text{PDU}_{d_z}\} \\ \mathcal{E}(\overline{H}_z) &= \mathcal{E}(G_k) \setminus \mathcal{E}(H_k).\end{aligned}$$

Observe that in the subgraph \overline{H}_z , there are no loads, and therefore, it does not depend on k .

Now, we divide the minimization problem (3) into the following minimization problems:

$$\begin{aligned}\text{minimize} \quad & \sum_{z=1}^q \left(a_{d_z} + \sum_{z'=z+1}^q b_{d_z, d_{z'}} \right) \\ \text{subject to} \quad & \lambda_{\overline{H}_z}(\text{PDU}_{d_z}, \text{xPPC}) \geq \max_{k \in \mathcal{L}_z} p_k, \quad \forall z \in \{1, \dots, q\}\end{aligned}\quad (4)$$

and for each $z \in \{1, \dots, q\}$

$$\begin{aligned}\text{minimize} \quad & \sum_{\substack{i, j \in \mathcal{D}_z \\ j > i}} b_{i, j} + \sum_{\substack{i \in \mathcal{D}_z \\ k \in \mathcal{L}_z}} c_{i, k} \\ \text{subject to} \quad & \lambda_{H_k}(L_k, \text{PDU}_{d_z}) \geq p_k, \quad \forall k \in \mathcal{L}_z \\ & \sum_{k \in \mathcal{L}_z} c_{i, k} \geq 1, \quad \forall i \in \mathcal{D}_z.\end{aligned}\quad (5)$$

Since $H_k \cup \overline{H}_z = G_k$ and $\mathcal{V}(H_k) \cap \mathcal{V}(\overline{H}_z) = \{\text{PDU}_{d_z}\}$, from Proposition 1, we have that for each $z \in \{1, \dots, q\}$

$$\lambda_{G_k}(L_k, \text{xPPC}) = \min\{\lambda_{H_k}(L_k, \text{PDU}_{d_z}), \lambda_{\overline{H}_z}(\text{PDU}_{d_z}, \text{xPPC})\}$$

for all $k \in \mathcal{L}_z$. Hence, for each $z \in \{1, \dots, q\}$, $\lambda_{G_k}(L_k, \text{xPPC}) \geq p_k$ for all $k \in \mathcal{L}_z$ if and only if $\lambda_{H_k}(L_k, \text{PDU}_{d_z}) \geq p_k$ for all $k \in \mathcal{L}_z$ and $\lambda_{\overline{H}_z}(\text{PDU}_{d_z}, \text{xPPC}) \geq \max_{k \in \mathcal{L}_z} p_k$.

Consequently, by combining the solutions obtained in the $q + 1$ minimization problems (4) and (5), we obtain a solution of the minimization problem (3). It should be noticed that the minimization problem (4) provides a fault-tolerant aircraft's power transmission network with the minimum number of cables between the xPPC and each zone. Similarly, the solutions to the minimization problems (5) provide for each zone a fault-tolerant power transmission network with the minimum number of cables between loads and PDUs in the zone.

IV. ALGORITHMS

In this section, we propose two algorithms that solve with low complexity the minimization problems (4) and (5).

Algorithm 1 Algorithm for the Design of a Fault-Tolerant Power Transmission Network Between the xPPC and Each Zone in One Side of the Aircraft

```

1:  $a_{\cdot} \leftarrow 0$ 
2:  $b_{\cdot, \cdot} \leftarrow 0$ 
3:  $z \leftarrow 0$ 
4: while  $\text{sum}(a_{\cdot}) < p_{\max}$  do
5:    $z \leftarrow z + 1$ 
6:   if  $a_{d_z} < p(z)$  then
7:      $a_{d_z} \leftarrow a_{d_z} + 1$ 
8:   end if
9:    $z \leftarrow z \bmod q$ 
10: end while
11: for  $z = 1 : \min(p_{\max}, q)$  do
12:   for all  $z' \in \{1 : \min(p(z), q)\} \setminus \{z\}$  do
13:     if  $\text{sum}(b_{d_z, \cdot}) + 1 < p(z) - a_{d_z}$  then
14:        $b_{d_z, d_{z'}} \leftarrow a_{d_{z'}} \quad (b_{d_{z'}, d_z} \leftarrow b_{d_z, d_{z'}})$ 
15:     end if
16:   end for
17: end for
18: for  $z = p_{\max} + 1 : q$  do
19:   if  $p(z) = 1$  then
20:      $a_{d_z} \leftarrow 1$ 
21:   else
22:     for  $\ell = 1 : z - 1$  do
23:       for all  $\ell' \in \{1 : z - 1\} \setminus \{\ell\}$  do
24:         if  $\text{sum}(b_{d_z, \cdot}) + 1 < p(z)$  and  $b_{d_\ell, d_{\ell'}} = 1$  then
25:            $b_{d_\ell, d_z} \leftarrow 1 \quad (b_{d_z, d_\ell} \leftarrow b_{d_\ell, d_z})$ 
26:            $b_{d_{\ell'}, d_z} \leftarrow 1 \quad (b_{d_z, d_{\ell'}} \leftarrow b_{d_{\ell'}, d_z})$ 
27:           if  $\text{sum}(b_{d_\ell, \cdot}) + a_{d_\ell} + 1 > p(\ell)$ 
28:             and  $\text{sum}(b_{d_{\ell'}, \cdot}) + a_{d_{\ell'}} + 1 > p(\ell')$  then
29:                $b_{d_\ell, d_{\ell'}} \leftarrow 0 \quad (b_{d_{\ell'}, d_\ell} \leftarrow b_{d_\ell, d_{\ell'}})$ 
30:             end if
31:           end if
32:         end for
33:       end for
34:     end if
35:   end for

```

We begin the section by introducing some notation. If \mathcal{A} is a finite set, $|\mathcal{A}|$ denotes the number of elements in \mathcal{A} . If x is a real number, $\text{floor}(x)$ denotes the largest integer not greater than x .

In this section, we assume that q is the number of zones in the left-hand side of an aircraft. Let $p(z) = \max_{k \in \mathcal{L}_z} p_k$ for all $z \in \{1, \dots, q\}$ be the maximum priority of the loads in zone z of the left-hand side of an aircraft. Without loss of generality, we assume that $p(1) \geq \dots \geq p(q)$ and define $p_{\max} = p(1)$. It should be noticed that due to the intrinsic symmetry of an aircraft, the number of zones and their priorities in the right-hand side are the same as in the left-hand side.

On the one hand, for solving the minimization problem (4), Algorithm 1 must be run for obtaining the connections between the xPPC and the zones of the left-hand side of the aircraft (observe that the connections between the xPPC and the zones of the right-hand side of the aircraft will be

Algorithm 2 Algorithm for the Design of a Fault-Tolerant Power Transmission Network in Each Zone [Minimization Problems (5)]

```

1:  $c_{i,:} \leftarrow 0$ 
2: for  $z = 1 : q$  do
3:    $s \leftarrow 0$ 
4:   for all  $k \in \mathcal{L}_z$  do
5:     if  $p_k/|\mathcal{D}_z| > 1$  then
6:       for  $\ell = 1 : |\mathcal{D}_z|$  do
7:          $i \leftarrow \ell^{\text{th}}$  element of  $\mathcal{D}_z$ 
8:         if  $\ell \leq p_k \bmod (|\mathcal{D}_z|)$  then
9:            $c_{i,k} \leftarrow \text{floor}(p_k/(|\mathcal{D}_z|)) + 1$ 
10:        else
11:           $c_{i,k} \leftarrow \text{floor}(p_k/(|\mathcal{D}_z|))$ 
12:        end if
13:      end for
14:    else
15:      for  $\ell = 1 : p_k$  do
16:         $s \leftarrow s + 1$ 
17:         $i \leftarrow s^{\text{th}}$  element of  $\mathcal{D}_z$ 
18:         $c_{i,k} \leftarrow c_{i,k} + 1$ 
19:         $s \leftarrow s \bmod (|\mathcal{D}_z|)$ 
20:      end for
21:    end if
22:  end for
23:  for all  $i \in \mathcal{D}_z \setminus \{d_z\}$  do
24:     $b_{i,d_z} \leftarrow \max(c_{i,:})$  ( $b_{d_z,i} \leftarrow b_{i,d_z}$ )
25:  end for
26: end for

```

TABLE I
EXPLANATION OF ALGORITHM 1

Lines	Description
4-10	Connect the xPPC with central PDUs using p_{\max} cables.
11-17	Connect the central PDUs directly powered by the xPPC with each other to guarantee the number of different routes needed between the xPPC and each zone with the minimum number of cables.
18-35	Connect the remaining central PDUs to guarantee the number of different routes needed between the xPPC and each zone with the minimum number of cables.

symmetric). Moreover, for each zone z in the left-hand side with $p(z) > 1$, the central PDU of that zone and its symmetric counterpart in the right-hand side must be connected with one cable.

On the other hand, for solving the minimization problem (5), Algorithm 2 must be run.

Finally, for the reader's convenience, Tables I and II describe Algorithms 1 and 2, respectively.

V. NUMERICAL EXAMPLE

In this numerical example, we compare the wiring under a traditional decentralized network configuration and the wiring

TABLE II
EXPLANATION OF ALGORITHM 2

Lines	Description
5	Under the framework of a balanced number of connections, the maximum number of cables between a PDU and a load is: $\text{floor}(p(z)/(\mathcal{D}_z)) + 1$. Loads that require such number of connections with a PDU are connected in lines 6-13. The rest of the loads are connected in lines 15-20.
6-13	Connect these loads by minimizing the number of PDUs that have the maximum number of connections with a given load.
15-20	Connect these loads so that the total number of connections between the loads and the PDUs is balanced.
23-25	Connect the PDUs to the PDU $_{d_z}$.

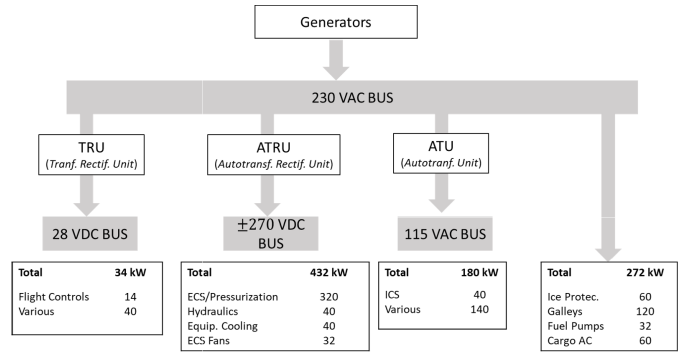

Fig. 3. Typical electrical system loads at cruise condition in Boeing 787 partially recreated from [37].

in the network provided by the novel algorithms presented in this article. We use this numerical example to quantify how many meters of cable our proposal saves.

In order to evaluate the proposed algorithms, we select Boeing 787 aircraft during cruise conditions since it has many novel MEA features and is an example of a decentralized EPS architecture (see, e.g. [38]). In this example, we consider a few electrical system loads in Boeing 787 (see Fig. 3), and we use the algorithms to design the subnetwork for powering some of the (\pm)270 V loads in the dc power system.

In the literature, it can be found some descriptions of the loads in an aircraft (see, e.g., [5], [37], [39]). The properties of the airplane's electrical system loads that we consider in this numerical example are given in Tables III and IV. According to [5, p. 268], these loads are fed by 21 PDUs located throughout the aircraft. This can be visualized in Fig. 4. In this figure, the airplane is divided into eight different zones (four in the right-hand side and four in the left-hand side).

Fig. 5 shows the connections between the HVPPC and the PDUs under a traditional decentralized network configuration where the redundancy option is employed in order to guarantee the fault-tolerance of the network. Fig. 6 shows the resulting interconnections between the HVPPC and the PDUs according to Section IV. Moreover, after running Algorithm 2 for each

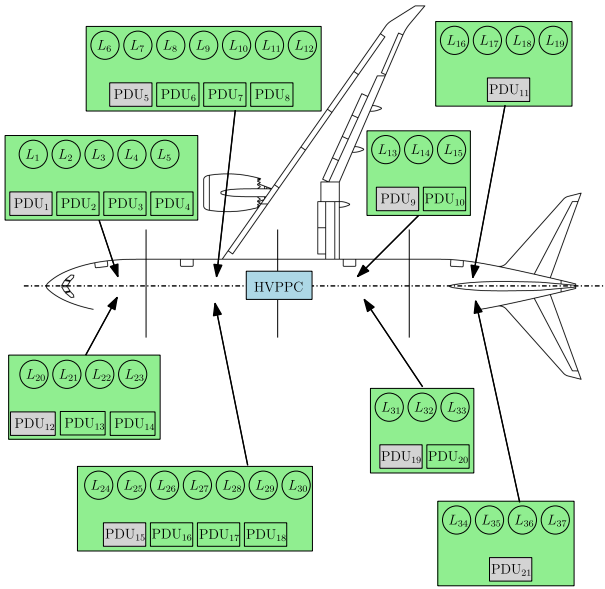

Fig. 4. Physical location of the devices of the considered subnetwork in Boeing 787. In the figure, the sketch of the aircraft is partially reproduced from [40].

TABLE III
PHYSICAL LOCATION OF DEVICES (PARTIALLY OBTAINED FROM [5], [37], AND [39])

zone	\mathcal{D}_z	d_z	\mathcal{L}_z
$z = 1$	{1, 2, 3, 4}	1	{1, 2, 3, 4, 5}
$z = 2$	{5, 6, 7, 8}	5	{6, 7, 8, 9, 10, 11, 12}
$z = 3$	{9, 10}	9	{13, 14, 15}
$z = 4$	{11}	11	{16, 17, 18, 19}
$z = 5$	{12, 13, 14}	12	{20, 21, 22, 23}
$z = 6$	{15, 16, 17, 18}	15	{24, 25, 26, 27, 28, 29, 30}
$z = 7$	{19, 20}	19	{31, 32, 33}
$z = 8$	{21}	21	{34, 35, 36, 37}

TABLE IV
DESCRIPTION OF THE CONSIDERED LOADS (PARTIALLY OBTAINED FROM [5], [37], AND [39])

Loads	Description	Priority	Power (kW)
1, 2, 3, 4, 6, 7, 8, 9, 13, 14, 16, 20, 21, 22, 24, 25, 26, 27, 31, 32, 34	ECS/ Pressurization	3	15.24
10,17,28,35	Hydraulics	3	10
11,18,29,36	Equip. Cooling	2	10
5, 12, 15, 19, 23,30, 33, 37	ECS Fans	1	4

zone, we would obtain the connections between the devices in each zone. As an example, Fig. 7 shows the connections provided by Algorithm 2 between the devices in the right-hand side zones.

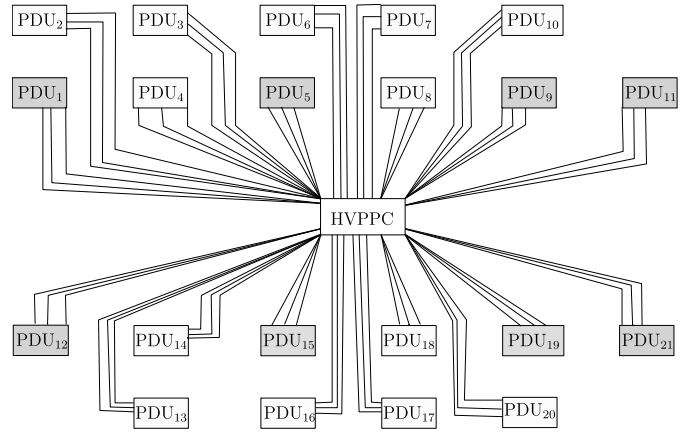

Fig. 5. Network between the HVPPC and the PDUs designed according to a traditional decentralized network configuration.

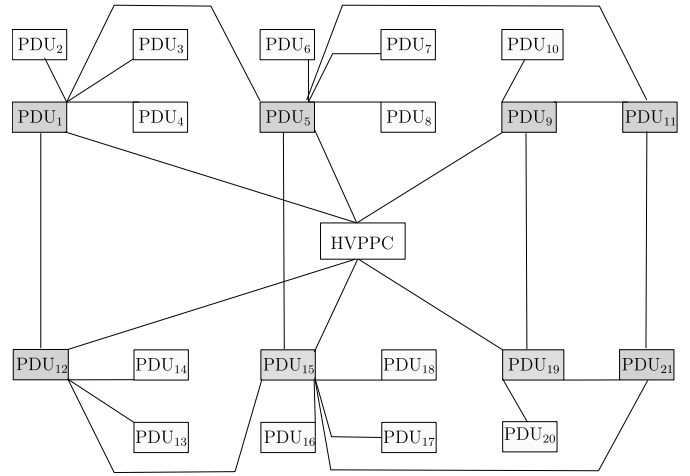

Fig. 6. Network between the HVPPC and the PDUs designed according to Section IV.

Regarding the connections between the PDUs and the loads, the number of cables that feed a particular load depends exclusively on its priority, and it remains the same whether we use the traditional decentralized network (where each load is fed by a single PDU) or the network obtained after running Algorithm 2 (where each load can be fed by several PDUs). Hence, in order to quantify how many meters of cable our proposal saves, we only need to compare the connections between the HVPPC and the PDUs, that is, the connections shown in Figs. 5 and 6. In order to quantify the length of the cables, we have combined the information shown in the figure in [5, p.268] (where the location of the 21 PDUs is sketched) with the dimensions of Boeing 787 aircraft. Specifically, we have considered the aircraft as a 2-D object and we have assumed that the length of the cables that connect two devices is the same as the straight line distance between such devices. Fig. 8 shows the distances among the central PDUs of each zone and the HVPPC. Moreover, we assume that the average distance among the PDUs located in the same zone is 5 m.

For the considered example, under a traditional decentralized network configuration where the redundancy option is

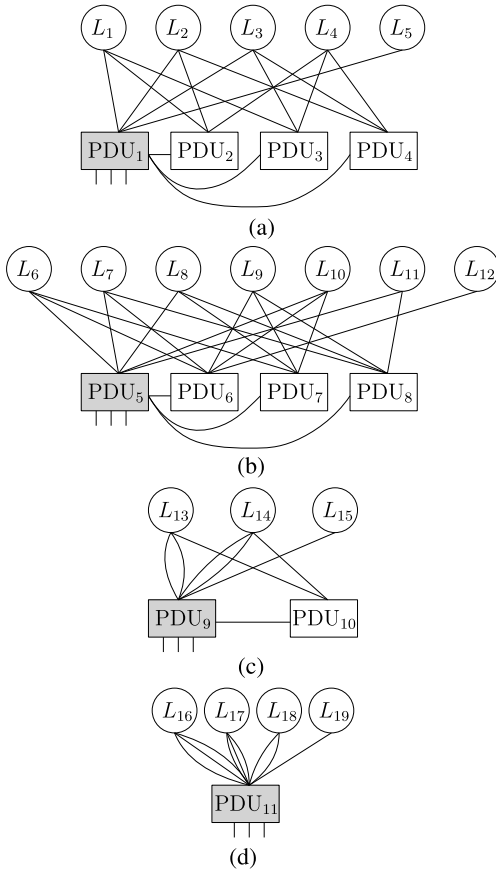

Fig. 7. Cables between the devices in each zone. (a) Zone 1. (b) Zone 2. (c) Zone 3. (d) Zone 4.

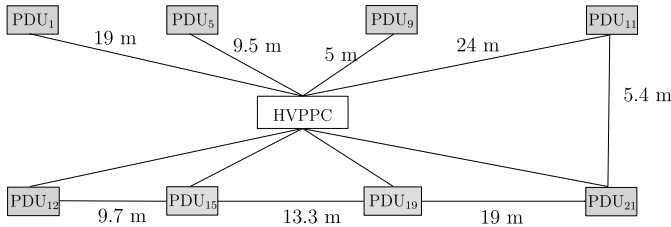

Fig. 8. Considered distances among the central PDUs of each zone and the HVPPC in Boeing 787 aircraft.

employed, 831 m of cables are needed to feed the PDUs from the primary power center. According to the network design proposed in Section IV, 278 m of cables are needed, which represents a saving of 66.6%.

It should be noticed that for the numerical example, we have considered that there are 21 ECS/pressurization loads, four hydraulics loads, four equipment cooling loads, and eight ECS fans. Observe that considering more loads of these types (with the same priorities and in the same zones) does not affect the network between the HVPPC and the PDUs, that is, the networks shown in Figs. 5 and 6 would remain the same. If there were more loads of these types, there would be more connections between the PDUs and the loads, but the network between the HVPPC and the PDUs would be the same. Consequently, the savings obtained using our algorithms

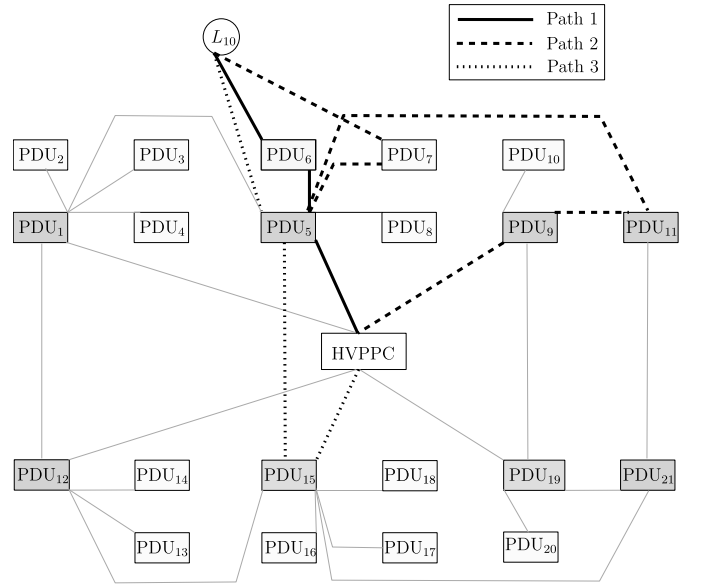

Fig. 9. Edge-disjoint paths from L_{10} to the HVPPC.

would remain the same unless we change the considered distances among PDUs and HVPPC.

Finally, Fig. 9 bears evidence of the reliability of the aircraft's EPS network. Specifically, if, for example, Load 10 is considered (priority three), the figure shows that there exist three different edge-disjoint paths from the HVPPC to the load.

VI. CONCLUSION

In recent years, based on the MEA concept, researchers have proposed several approaches related to the aircraft's EPS architecture to increase the whole aircraft's efficiency and their fault-tolerant ability. In this article, we have addressed the problem of achieving the target reliability with the minimum wiring under a decentralized EPS strategy, considering that the PDUs are provided with software and hardware modifications proposed in [28] and [29].

In order to guarantee the reliability with the minimum number of cables, we need to solve a minimization problem. However, the complexity of such minimization problem grows exponentially with the number of devices, making exhaustive search intractable. To handle the former minimization problem, we have made some assumptions regarding the physical location of devices, we have used the divide-and-conquer technique and designed two algorithms to solve the resulting minimization problems. Specifically, we have presented two very low-complexity algorithms to connect the devices with the minimum number of cables and guaranteeing the number of different routes needed to keep each load's priority level. One algorithm establishes the connections between the xPPC and each zone of the aircraft, while the second algorithm establishes the connections between the PDUs and the loads in each zone.

In order to evaluate our algorithms, we have compared the length of the cables under a traditional decentralized network configuration and the length of the cables in the network provided by our algorithms. To that end, a few loads of

the (\pm)270 V (dc) power transmission subnetwork of the Boeing 787 aircraft have been examined. In the considered example, we saved 66.6% of wiring between the xPPC and the PDUs. The main conclusion of our work is that, by using the proposed algorithms, the total weight of the aircraft's EPS can be significantly reduced.

REFERENCES

- [1] P. Wheeler and S. Bozhko, "The more electric aircraft: Technology and challenges," *IEEE Electrific. Mag.*, vol. 2, no. 4, pp. 6–12, Dec. 2014.
- [2] K. Emadi and M. Ehsani, "Aircraft power systems: Technology, state of the art, and future trends," *IEEE Aerosp. Electron. Syst. Mag.*, vol. 15, no. 1, pp. 28–32, Jan. 2000.
- [3] R. Quigley, "More electric aircraft," in *Proc. 8th Annu. Appl. Power Electron. Conf. Expo.*, Mar. 1993, pp. 906–911.
- [4] C. R. Spitzer, "The all-electric aircraft: A systems view and proposed nasa research programs," *IEEE Trans. Aerosp. Electron. Syst.*, vol. AES-20, no. 3, pp. 261–266, May 1984.
- [5] I. Moir, A. Seabridge, and M. Jukes, *Civil Avionics System*. London, U.K.: Professional Engineering Publishing, 2013.
- [6] M. J. Provost, "The more electric aero-engine: A general overview from an engine manufacturer," in *Proc. Int. Conf. Power Electron. Mach. Drives*, Jun. 2002, pp. 246–251.
- [7] J. Ramsey, "Power-by-wire," in *Avionics Magazine*. Rockville, MD, USA: Access Intelligence, 2001.
- [8] R. T. Naayagi, "A review of more electric aircraft technology," in *Proc. Int. Conf. Energy Efficient Technol. Sustain.*, Apr. 2013, pp. 750–753.
- [9] X. Zhao, J. M. Guerrero, and X. Wu, "Review of aircraft electric power systems and architectures," in *Proc. IEEE Int. Energy Conf. (ENERGYCON)*, May 2014, pp. 949–953.
- [10] S. J. Cutts, "A collaborative approach to the more electric aircraft," in *Proc. Int. Conf. Power Electron. Mach. Drives*, 2002, pp. 223–228.
- [11] J. Chen, C. Wang, and J. Chen, "Investigation on the selection of electric power system architecture for future more electric aircraft," *IEEE Trans. Transport. Electrific.*, vol. 4, no. 2, pp. 563–576, Jun. 2018.
- [12] I. Cotton and A. Nelms, "Higher voltage aircraft power systems," *IEEE Aerosp. Electron. Syst. Mag.*, vol. 23, no. 2, pp. 25–32, Feb. 2008.
- [13] I. Moir and A. Seabridge, *Aircraft Systems: Mechanical, Electrical and Avionics Subsystems Integration* (Aerospace Series). Hoboken, NJ, USA: Wiley, 2008.
- [14] S. Mollov, A. Forsyth, and M. Bailey, "System modeling of advanced electric power distribution architectures for large aircraft," *SAE Trans.*, vol. 109, pp. 904–913, Oct. 2000.
- [15] T. Schroter and D. Schulz, "The electrical aircraft network—Benefits and drawbacks of modifications," *IEEE Trans. Aerosp. Electron. Syst.*, vol. 49, no. 1, pp. 189–200, Jan. 2013.
- [16] *Global Market Forecast 2015–2034*. Accessed: Jun. 22, 2021. [Online]. Available: <https://www.airbus.com/aircraft/market/global-market-forecast.html>
- [17] *Current Market Outlook 2014–2034*. Accessed: Jun. 22, 2021. [Online]. Available: https://www.pista73.com/media/2012/07/Boeing_Global_Market_Outlook_2014_2034.pdf
- [18] *European Aeronautics: A vision for 2020*. Accessed: Jun. 22, 2021. [Online]. Available: https://www.acare4europe.org/sites/acare4europe.org/files/document/Vision%202020_0.pdf
- [19] *European Commission Flightpath 2050*. Accessed: Jun. 22, 2021. [Online]. Available: https://www.acare4europe.org/sites/acare4europe.org/files/document/Flightpath2050_Final.pdf
- [20] D. Lee, L. Lim, and B. Owen, "The impact of the '2020 carbon neutral goal' on aviation CO₂ radiative forcing and temperature response," *Dalton Res. Inst., Manchester Metropol. Univ., Manchester, U.K., Tech. Rep. CNG2020*, 2013.
- [21] A. Barzegar *et al.*, "Intelligent power allocation and load management of more electric aircraft," in *Proc. IEEE 11th Int. Conf. Power Electron. Drive Syst.*, Jun. 2015, pp. 533–538.
- [22] M. Terorde and D. Schulz, "New real-time heuristics for electrical load rebalancing in aircraft," *IEEE Trans. Aerosp. Electron. Syst.*, vol. 52, no. 3, pp. 1120–1131, Jun. 2016.
- [23] A. G. Garriga, P. Govindaraju, S. S. Ponnusamy, N. Cimmino, and L. Mainini, "A modelling framework to support power architecture trade-off studies for more-electric aircraft," *Transp. Res. Proc.*, vol. 29, pp. 146–156, Jan. 2018.
- [24] Y. Jia and K. Rajashekara, "Induction machine for more electric aircraft: Enabling new electrical power system architectures," *IEEE Electrific. Mag.*, vol. 5, no. 4, pp. 25–37, Dec. 2017.
- [25] D. Sziroczak, I. Jankovics, I. Gal, and D. Rohacs, "Conceptual design of small aircraft with hybrid-electric propulsion systems," *Energy*, vol. 204, Aug. 2020, Art. no. 117937.
- [26] R. Alexander, D. Meyer, and J. Wang, "A comparison of electric vehicle power systems to predict architectures, voltage levels, power requirements, and load characteristics of the future all-electric aircraft," in *Proc. IEEE Transp. Electrific. Conf. Exp. (ITEC)*, Jun. 2018, pp. 194–200.
- [27] C. Gu *et al.*, "A multiport power conversion system for the more electric aircraft," *IEEE Trans. Transport. Electrific.*, vol. 6, no. 4, pp. 1707–1720, Dec. 2020.
- [28] F. Rodríguez, G. Martínez, S. Rodríguez, and J. M. Echeverría, "Increasing the safety of more electric aircraft through a novel algorithm in the DC power system," *Int. J. Electr. Power Energy Syst.*, vol. 126, Mar. 2021, Art. no. 106566.
- [29] G. Martínez, F. R. Lalanne, I. Sánchez-Guardamino, S. R. Benito, and J. M. Echeverría, "Novel modular device for a decentralised electric power system architecture for more electric aircraft," *IEEE Access*, vol. 10, pp. 19356–19364, 2022.
- [30] G. Buticchi, L. F. Costa, and M. Liserre, "Multi-port DC/DC converter for the electrical power distribution system of the more electric aircraft," *Math. Comput. Simul.*, vol. 158, pp. 387–402, Apr. 2019.
- [31] *Cleansky*. Accessed: Jun. 22, 2021. [Online]. Available: <https://www.clean-aviation.eu/clean-sky-2/programme-overview-and-structure/clean-sky-2-structure/systems-itd>
- [32] S. L. Hakimi, "Steiner's problem in graphs and its implications," *Networks*, vol. 1, no. 2, pp. 113–133, 1971.
- [33] A. Y. Levin, "Algorithm for the shortest connection of a group of graph vertices," in *Doklady Akademii Nauk*, vol. 200, no. 4. Moscow, Russia: Russian Academy of Sciences, 1971, pp. 773–776.
- [34] F. K. Hwang and D. S. Richards, "Steiner tree problems," *Networks*, vol. 22, no. 1, pp. 55–89, Jan. 1992.
- [35] B. Bollobás, *Modern Graph Theory*. New York, NY, USA: Springer-Verlag, 1998.
- [36] F. Harary, *Graph Theory* (Addison Wesley Series in Mathematics). Reading, MA, USA: Addison-Wesley, 1971.
- [37] G. A. Whyatt and L. A. Chick, "Electrical generation for more-electric aircraft using solid oxide fuel cells," Pacific Northwest Nat. Lab. (PNNL), Richland, WA, USA, Tech. Rep. PNNL-21382, 2012.
- [38] B. Sarlioglu and C. T. Morris, "More electric aircraft: Review, challenges, and opportunities for commercial transport aircraft," *IEEE Trans. Transport. Electrific.*, vol. 1, no. 1, pp. 54–64, Jun. 2015.
- [39] M. J. Salehpour, H. Radmanesh, S. M. H. Rostami, J. Wang, and H.-J. Kim, "Effect of load priority modeling on the size of fuel cell as an emergency power unit in a more-electric aircraft," *Appl. Sci.*, vol. 9, no. 16, p. 3241, Aug. 2019.
- [40] *Schematics of Boeing 787–800. Side, Top, Front, Section*. Accessed: Jun. 22, 2021. [Online]. Available: <https://commons.wikimedia.org/wiki/File:B787-800v1.0.png>



Marta Zárraga-Rodríguez was born in Oviedo, Spain. She received the B.Sc., M.Sc., and Ph.D. degrees in industrial engineering and the Ph.D. degree in applied engineering from the University of Navarra, San Sebastián, Spain, in 1993, 1993, 1999, and 2017, respectively.

She is currently an Assistant Professor with Tecnun, University of Navarra. Her research interests include matrix analysis applied to problems in statistical signal processing, distributed computation, and information theory.



Xabier Insausti was born in Beasain, Spain. He received the B.Sc. and M.Sc. degrees in telecommunications engineering from the University of Navarra, San Sebastián, Spain, in 2009, the M.Sc. degree in advanced mathematics from the Universidad Nacional de Educación a Distancia (UNED), Madrid, Spain, in 2013, and the Ph.D. degree in telecommunications engineering from the University of Navarra in 2013.

He is currently an Associate Professor with Tecnun, University of Navarra. His research interests include matrix analysis applied to problems in statistical signal processing, distributed computation, telecommunications, and information theory.

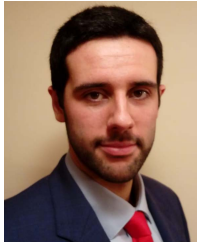

Fermín Rodríguez Lalanne was born in San Sebastián, Spain, in 1993. He received the M.Sc. degree in industrial engineering and the Ph.D. degree from Tecnun, University of Navarra, San Sebastián, in 2017 and 2021, respectively.

From 2017 to 2022, he worked on applied research projects not only in the development and design of novel hardware and software in power electronics but also in the development of novel devices to increase the decentralization of power systems at the Centro de Estudios e Investigaciones Técnicas (CEIT), Basque Research and Technology Alliance (BRTA), San Sebastián. Since 2022, he has been working on the development of novel artificial intelligent energy demand and generation forecasters on Tecnalia Research and Innovation (TRI), BRTA. He has authored or coauthored about 15 scientific and technical publications in international journals and conference proceedings.



Javier Velasco received the Industrial Engineering degree from Mondragon University, Mondragón, Spain, in 2009, and the master's degree in space science and technology and the Ph.D. degree in control engineering from the University of the Basque Country (UPV/EHU), Leioa, Spain, in 2011 and 2021, respectively. The main objective of this thesis is the development of advanced control and communication techniques aimed at aeronautical devices, in particular, the design and implementation of different intelligent control strategies that allow controlling

different types of actuators with high precision and adequate response.

Since 2009, he has been working as the Advanced Manufacturing Project Manager with the Aeronautical Technologies Centre (CTA), Miñano, Spain.



Jesús Gutiérrez-Gutiérrez (Senior Member, IEEE) was born in Granada, Spain. He received the B.Sc. and M.Sc. degrees in mathematics from the University of Granada, Granada, in 1999, and the Ph.D. degree in electronics and communications from the University of Navarra, San Sebastián, Spain, in 2004.

He is currently a Full Professor with Tecnun, University of Navarra. He is also the Head of the Department of Biomedical Engineering and Sciences, Tecnun. His research interests include matrix analysis applied to problems in statistical signal processing, distributed computation, and information theory.