

Simultaneous Wireless Power and Data Transfer for Electric Vehicle Charging: A Review

Inmaculada Casaucao Tenllado¹, Alicia Triviño Cabrera², and Zhengyu Lin³, *Senior Member, IEEE*

Abstract—Wireless charging of electric vehicles (EVs) has become an important research topic in recent years. During the wireless charging process, wireless data exchange must take place between the EV and the charging station. Battery status, current, and voltage of the charger or the EV identification may be required on the primary side in order for the system to operate properly. This data exchange can be carried out through commercial wireless communication solutions, such as Bluetooth, 802.11, or Zigbee. However, these technologies introduce cybersecurity problems, high and variable transmission delays, and possible connection losses during communication. To address these issues, numerous solutions have been proposed based on wireless data transmission through the wireless power transfer circuit. This article gives a comprehensive review of the different issues that need to be considered for simultaneous wireless power and data transfer (SWPDT) for wireless EV charging applications. This context represents a challenge for SWPDT due to the power levels and the high probability of operating with notable misalignments or even with the EV on the move. Specifically, a classification of SWPDT systems is described, and six different criteria to consider when designing an SWPDT system are analyzed for EVs. The suitability of different system configurations is evaluated according to three representative use cases: 1) providing maximum efficiency; 2) synchronization for bidirectional wireless chargers; and 3) dynamic charging. We have also analyzed the feasibility of using the open charge point protocol (OCPP) together with ISO 15118, which is the most popular communication protocol used in EV charging infrastructures.

Index Terms—Electric vehicles (EVs), inductive resonant charging, ISO 15118, open charge point protocol (OCPP), simultaneous wireless power data transfer.

I. INTRODUCTION

WIRELESS electric vehicle (EV) charging has gained popularity in recent years due to the advantages that it brings. Through wireless EV charging, the driver's intervention in the charging process is limited, as it is carried out

automatically. In this way, charging an EV would become a more comfortable process [1]. For this reason, a large amount of research is currently focused on implementing a design that efficiently replaces the conventional conductive charging method with wireless charging.

The general structure of an inductive-resonant charger is illustrated in Fig. 1. For EV charging, the primary circuit is located in the electric vehicle supply equipment (EVSE), and the secondary circuit is located in the EV.

During any conductive or wireless charging process, power must be exchanged between the EV and EVSE in a controllable way. In some cases, WPT solutions with no communication between the EV and the EVSE are proposed [2], [3], [4]. In these solutions, secondary side sensorless wireless charging is employed. However, communication between primary and secondary sides is advantageous for monitoring system status and operation control. Thus, in the field of wireless charging of EVs, sensorless systems are not the most widely used solution according to the literature reviewed. Thus, information is frequently required for choosing the correct charging method, such as constant current charging or constant voltage charging, as indicated in [5]. Thus, not only power is transmitted but information must also be exchanged between the vehicle and the charging base in order to facilitate the charge (e.g., battery status, current, or voltage in some points of the charger) or the user management (such as vehicle identification, energy demand, battery status, or warning messages) [6]. For the interoperability of the infrastructures and the wired charging stations, a communication protocol should be implemented. One of the best-known protocols is the open charge point protocol (OCPP), which works between EVSE and the charging station management system (CSMS) [7].

In the case of OCPP, the ISO 15118 standard is used for communication between the EV and EVSE. This is necessary to mention since, as in the case of wired chargers, the transmission of information in wireless chargers must also be achieved through a communication protocol. For this reason, the feasibility of using these two protocols will be discussed in Section IV. Furthermore, in wireless chargers, it is also commonly required to transmit information associated with the secondary side current/voltage or the battery state of charge [6], [8] so that it serves as feedback for the primary control circuit. In this way, the controller can adjust the power converters on the primary and/or secondary sides to guarantee that the battery charges correctly, as can be seen in Fig. 1.

Manuscript received 15 November 2022; revised 23 February 2023 and 20 June 2023; accepted 16 August 2023. Date of publication 28 August 2023; date of current version 18 June 2024. This work was supported in part by the Spanish Ministerio de Educación, Cultura y Deporte, José Castillejo Programme, under Mobility Grant CAS 17-00318; in part by the Spanish Ministerio de Ciencia e Innovación (MICINN) under Project PID2019-110531-RA-I00/AEI/10.13039/501100011033 of the Proyectos de I+D+i-RTI Tipo A; in part by the University of Málaga under Project D5-2021-09; and in part by Universidad de Málaga/CBUA. (Corresponding author: Inmaculada Casaucao Tenllado.)

Inmaculada Casaucao Tenllado and Alicia Triviño Cabrera are with the Department of Electrical Engineering, University of Málaga, 29016 Málaga, Spain (e-mail: icct@uma.es; atc@uma.es).

Zhengyu Lin is with the Wolfson School of Mechanical, Electrical and Manufacturing Engineering, Loughborough University, LE11 3TU Loughborough, U.K. (e-mail: z.lin@ieee.org).

Digital Object Identifier 10.1109/TTE.2023.3309505

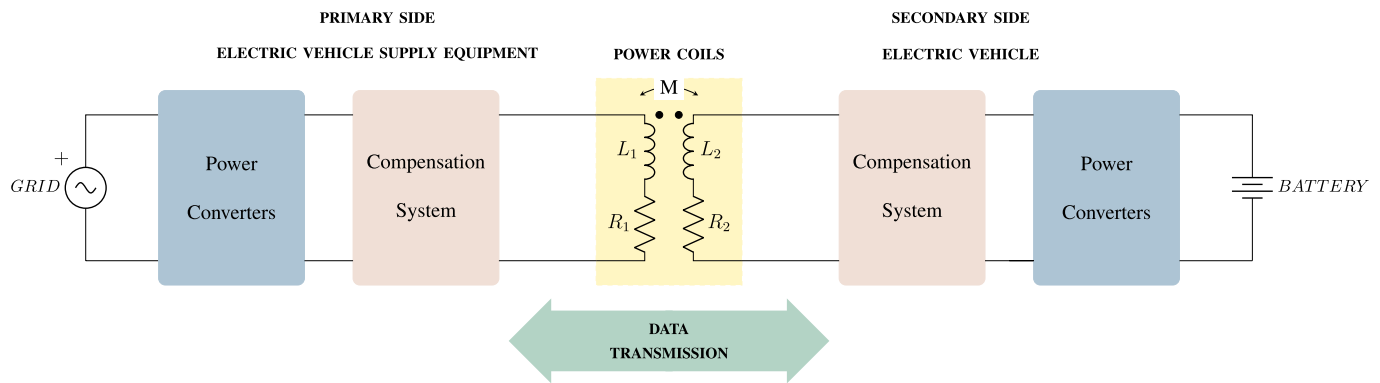

Fig. 1. WPT generic system scheme.

If the charging process is carried out wirelessly, the data transmission process must be done in the same way, and without the driver's intervention, so that information exchange does not complicate the charging process. Currently, there are numerous commercial noncontact data transmission platforms—such as Bluetooth, Bluetooth low energy (BLE), Zigbee, radio frequency (RF), and IEEE 802.11 (Wi-Fi)—that can be used for this purpose. Both Bluetooth and Zigbee or 802.11 work in the 2.4-GHz band, and they have the advantage of having a relatively high data transmission rate, from 250 kb/s in the case of Zigbee [9] to the order of megabits per second (Mb/s) in the case of Bluetooth [10], BLE [11], and 802.11 [12].

These commercial products are often an economical option; however, they have some drawbacks that may hinder data transmission for EV wireless charging applications, such as the following.

- 1) The pairing process, where the vehicle data controller may be unable to connect to the charging station.
- 2) Possible connection loss during the information exchange due to interference from other devices, weak connection, or the deterioration of the antennas used, preventing the system from functioning properly.
- 3) Long transmission delays (up to 6 ms in the case of RF [13] and up to 46 ms in the case of BLE [14]).
- 4) The bit error rate (BER) of RF depends on the WPT power level, as indicated in [15]. Thus, the higher the power level, the more degraded the BER.
- 5) Cybersecurity problems, which make information more vulnerable to attackers [16], [17]. In the case of Bluetooth, attackers use numerous methods to hack into devices, such as Bluesnarfing [18], [19], Bluejacking [20], or fuzzing attack [21]. These vulnerabilities, among others, could cause numerous problems for the charging infrastructure and the vehicle itself. These cybersecurity issues can also occur in the pairing process between devices, as noted in [22] and [23]. For 802.11, there are techniques such as the use of packet sniffers, among others, where an attacker can access and intercept all the data circulating in and sent through the network, including the vehicle driver's personal information [24]. In Zigbee, different attacks can be categorized according to different criteria, such as the layer that they

affect or the method used [25]. Thus, there are various threats to Zigbee devices, such as eavesdropping [26] or data manipulation or injection, which, as indicated by Vidgren et al. [27], can be carried out with low-cost devices easily available to attackers.

- 6) The sequence of the communication phases is variable, which leads to difficulties and uncertainty in latency estimation.

In addition to the above-cited problems, the infrastructure required to establish data communication between the two sides of the circuit can be more costly and less reliable in high nominal power WPT systems, as is the case for RF [28]. For these reasons, a large amount of recent research focuses on data transmission through the WPT power circuit itself. This makes the system more reliable, as communication is in real time and no pairing process between devices is needed to carry out an information exchange. Several solutions have been proposed, which make use of the WPT power transmission circuit to send and transmit all the information relevant to the charging process, thus eliminating the aforementioned risks. These are called simultaneous wireless power data transfer (SWPDT) or simultaneous wireless information power transfer (SWIPT) [29]. This definition includes both circuits in which a power signal and one or more data signals coexist and all those in which a slight modification of the power signal is equivalent to the transmission of data during the charging process.

The way of combining data and power transmission in WPT systems can be implemented in multiple ways, establishing differences in terms of the number of signals and transmission channels used, the way in which the signals are combined (in the event that two or more different signals coexist in the same circuit), the type of communication established, and even the modulation of the transmitted data. It is also possible to differentiate between the compensation systems used, as well as the electronic circuits used to inject the data signal into the system.

Research work on EV wireless charging focuses on different aspects such as dynamic charging (which is one of the analyzed case studies in Section III) [30], vehicle positioning [31], or developing WPT power converters for EVs [32]. On the particular topic of combining power and data transfer, several review papers have been presented related to simultaneous wireless power and data transfer systems in far-field

applications, as described in [33], [34], and [35]. As for near-field applications, a few reviews have been found in [36], [37], [38], and [39]. As shown in Table I, only [37] and this article address EV wireless charging as the main topic, while the rest discusses general applications [36] or medical implants [38], [39]. The power levels and modes of operation of power transmission in EVs are different from biomedical ones in terms of power and degrees of misalignment, which influences power and data transmission and their potential interferences.

The reviews analyzed coincide in classifying the prototypes according to the number of signals and links. This article extends the classification by proposing six criteria; that is, we add the analysis of the number of signals and links, data communication, signal combination, data modulation, the data injection/extraction method, and compensation systems. The suitability of each configuration associated with the analyzed criteria is carried out for the particularities that EVs impose. Another point mentioned in this article is the geometry of the power coils, which is directly related to the misalignment tolerance of the charging system and with potential effects on the data transmission. The most commonly used geometries in SWPDT systems have been analyzed, highlighting the advantages and disadvantages of each of them. These criteria are relevant to the design and implementation of the SWPDT system.

Moreover, unlike the other reviews, this article analyses the feasibility of these types of solutions according to the requirements imposed by ISO 15118-2. These requirements include the bit rate and the type of communication channel, among others. Finally, this article presents a comparative analysis of the solutions, ending with some final conclusions in which we analyze the current status of SWPDT systems and future lines of research related to this topic. Gathering information on the state of the art on this topic is useful for optimizing SWPDT systems in future research and may encourage the design of new techniques to improve previous ones.

As a brief summary, the main contributions of this article are given as follows.

- 1) Classification and analysis of SWPDT systems according to six different criteria: analysis of the number of signals and links, data communication, signal combination, data modulation, the data injection/extraction method, and compensation systems. The study has been performed considering the particularities of the EV applications. Specifically, we have analyzed them taking into account the communication requirements of EV services and the particular misalignment and gap conditions expected in these vehicles, which are not so severe in other scenarios as medical implants.
- 2) Analysis of design criteria within the main classification based on the number of channels and signals. The design criteria are operating frequency, data rate (DR), electronics, crosstalk minimization, and coil geometry. We have evaluated the criteria considering the operational power frequencies imposed by the international standards for EVs, which is notably different from those

used in wireless chargers for other areas as in biomedical applications.

- 3) Study of different use cases of potential interest for EVs. We have evaluated the suitability and configuration of the SWPDT technology to provide adequate performance. The case studies are given as follows:
 - a) maximum efficiency control to cope with EV misalignment;
 - b) synchronization between power converters for bidirectional EV chargers;
 - c) dynamic charging to control the power flow for EVs on the move.
- 4) Study on the feasibility of using the OCPP protocol, widely deployed in EV charging stations, with SWPDT.
- 5) Comparative analysis of the different current SWPDT solutions proposed in the literature in terms, mainly, of the frequency used, the bit rate achieved, and the misalignment conditions tested.
- 6) Discussion of possible future works related to SWPDT systems for EV wireless charging.

This article is structured as follows. Section II gives a description of EV inductive chargers. Section III describes the case studies proposed for the integration of an SWPDT system in an EV wireless charger. A classification of proposed solutions according to different criteria can be found in Sections V–XI. This article concludes with comparative analysis in Section XII and a closing description of future research trends in Section XIV.

II. BASIC OPERATION OF EV INDUCTIVE CHARGERS

One of the main elements to consider when designing an inductive WPT or SWPDT charging system for EVs is the coil used for power transmission. Currently, two main types of coils can be distinguished for WPT systems: unpolarized coils (circular, square, and rectangular) or polarized coils [double-D (DD) and DD quadrature (DDQ)] [40], [41], [42], as can be seen in Fig. 2. All these different geometries can also be found in an SWPDT system. Furthermore, in order to improve the coupling between the windings and the quality factor, ferrite plates or bars need to be optimally designed.

The misalignment tolerance is directly related to coil geometry. As studied in [43], circular and DD coils have a poor tolerance to misalignment. In contrast, the geometry with the highest misalignment tolerance of the abovementioned geometries is the DD-Q pad. On the other hand, rectangular coils offer a higher misalignment tolerance than circular coils, as demonstrated in [44].

In order to maximize the power transfer capability and minimize the VA rating of the power electronics supply [45], it is necessary to design a compensation system, both in the primary and secondary windings, so that both work in resonance at a given frequency. In its most basic form, the compensation system includes a capacitor in series/parallel with the primary and secondary coils although other more complex configurations can be found. The four basic power transmission compensation systems (monoresonant topologies), as cited in [46], can be seen in Fig. 3, where the

TABLE I
SUMMARY OF THE MOST RELEVANT REVIEWS ON SWPDT TECHNOLOGY

Ref.	Application of study	Fundamentals of WPT systems	Analysis of a communication protocol	Classification						Analysis		
				Number of links and signals	Data communication type	Signal multiplexing technique	Data modulation	Data injection/extraction	Compensation system found in literature	Data rate analysis	Comparative analysis	
[37]	Electric Vehicles			✓								
[36]	General applications			✓	Mentioned but no analysis		✓	✓		Optimal CSS are mentioned, but there is no analysis of the CSS used in the literature.	✓	✓
[38]	Implanted devices	✓		✓			✓			Basic CSS are mentioned, but there is no analysis of the CSS used in the literature.	✓	✓
[39]	Medical implants	✓					✓				✓	✓
Proposal	Electric Vehicles	✓	✓	✓	✓	✓	✓	✓	✓		✓	✓

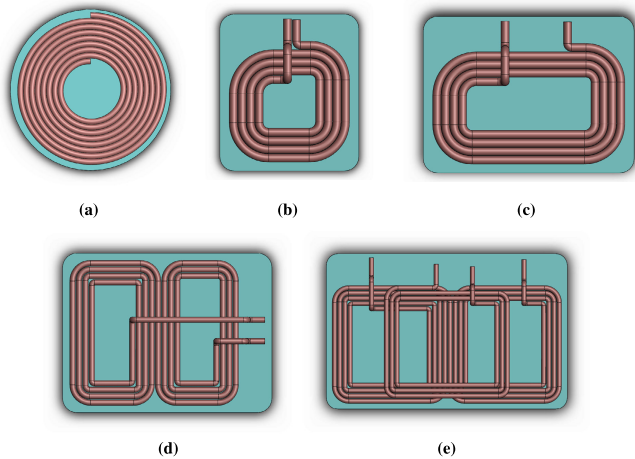

Fig. 2. Coil designs: (a) circular, (b) square, (c) rectangular, (d) DD, and (e) DDQ.

difference between the different configurations can be checked. It should be mentioned that V_{in} is the rms output voltage of the primary converter and R_{BAT} refers to the equivalent ac battery resistance. In series-series (SS) and series-parallel (SP) compensation systems, the capacitor C_1 is found in series connection with the primary coil, while the capacitor C_2 is connected in series (SS) or parallel (SP) with the secondary coil. In the case of parallel-series (PS) and parallel-parallel (PP) compensation systems, the capacitor C_1 is connected in parallel with the primary coil, while the capacitor C_2 is found in series (PS) or parallel (PP) with the secondary coil.

However, more elements can be included in compensation systems, resulting in more complex structures (multiresonant topologies), such as *LCC* compensation. In this case, an extra inductor is included along with a capacitor in series and another in parallel with the main winding, repeating the structure in both parts of the circuit. A simplification of

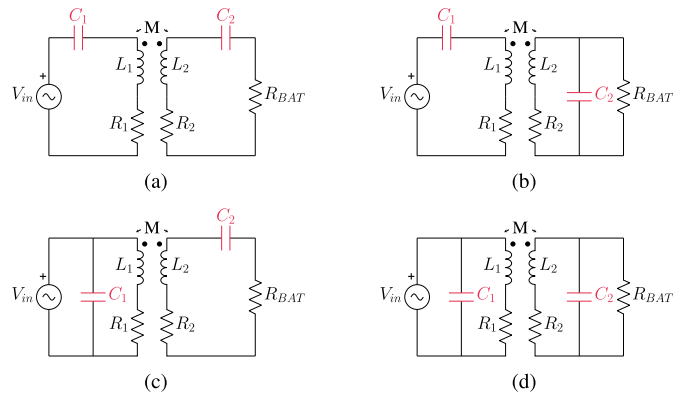

Fig. 3. Monoresonant compensation systems: (a) SS, (b) SP, (c) PS, and (d) PP.

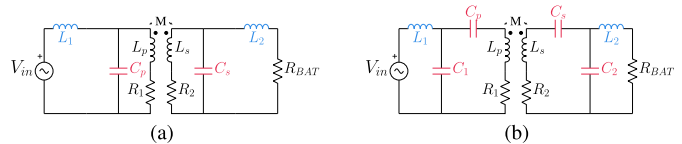

Fig. 4. Multiresonant compensation systems: (a) *LCL* and (b) *LCC*.

the *LCC* compensation system is the *LCL*, where a coil is connected in series and a capacitor in parallel with the main winding. These two topologies, which can be seen in Fig. 4, can be used when it is necessary to reduce data transmission latencies in the control system, as they eliminate cycle-by-cycle control, allowing feedback control to have low sampling rates in the order of 1 Hz or even 0.1 Hz.

The performance of the WPT in cases of misalignment strongly depends on the compensation systems used. Variations in the amplitude or the phase of the signals may be more significant with certain compensation systems. If perfectly tuned, the series-to-series compensation does not undergo any

TABLE II
SOME EXAMPLES OF CONTROLLED VARIABLES
REQUIRED IN A WPT SYSTEM

Required data	Control type	Ref.
Output voltage	Primary side	[60], [53]
	Secondary side	[55], [61]
Output current	Dual side	[62], [63]
Output power	Primary side	[64]
Input power	Dual side	[51]
Primary inverter voltage	Primary side	[52], [65]
Primary current	Primary side	[66]

phase change. For other systems, the phase and amplitude of the signals vary with some coil displacement, as described in [5].

Fig. 1 shows how power converters are usually needed in a WPT system to convert alternating current (ac) power into direct current (dc) power (ac–dc rectifiers) or vice versa (dc–ac inverters). Currently, the SAE J2954 standard states that the nominal operating frequency should be 85 kHz [47] although this frequency was generally set around 20 kHz according to previous works [48], [49], [50]. As a result, both the compensation system and the choice of power converter components are designed and chosen, respectively, for this frequency. Power switching devices, such as SiC MOSFETs or IGBTs, are the main components of power converters. Thus, it is necessary to evaluate their performance depending on the operating frequency.

Finally, in a WPT system for EVs, it is imperative to control the power delivered to the EV batteries to guarantee a proper charging process and prolong the battery lifetime. There are three control types depending on where the control is applied [51]: primary side [52], [53], secondary side [54], [55], [56], [57], or dual-side [58], [59]. In order to optimize the control, variables such as voltage, current, and power should be monitored on both sides. In some implementations, the values of these variables need to be transmitted from the primary side to the secondary side and vice versa. In Table II, several examples of these variables can be found.

III. DATA TRANSFER BETWEEN EV AND EVSE: CASE STUDIES

Within the field of wireless charging, there are research lines that study in depth the improvement of different functionalities of this type of charger. In this section, we present some areas that, we believe, can be a field of application for SWPDT systems.

They are representative use cases in which the communication delay must be estimated with precision in order to ensure the correct and efficient performance of the system. Commercial communication technologies fail in the provision of the delay value. Since they have been developed with complex communication protocols with an uncertain sequence of phases, the estimation of some communication-related parameters (particularly, the delay or latency) is not trivial [67], and the delay may be excessive for some service applications

running in EV wireless charging (with values on the order of milliseconds in BLE [14], BL [68], or 802.11 [69]). A suitable and customized communication protocol can be implemented with SWPDT, in which the use of simple phases may favor the correct performance of the specific operation of EV wireless chargers. The particular cases in which SWPDT is of interest are described next.

A. Maximum Efficiency Control

Due to the power level involved in EVs, many of the solutions proposed in the literature for wireless charging aim for maximum efficiency control [51], [70], [71], but the performance of an inductive charger could be equivalent to that of a conductive charger. In the control algorithms proposed for reaching the point of maximum efficiency, it is common to use a communication system that allows the exchange of parameters between both parts of the circuit, such as load voltage, load current, or battery status. Therefore, it is possible to deduce that, for this type of system, the communication between the primary and secondary circuits must be robust, avoiding connection losses, pairing problems, or latencies. For this reason, it is possible to consider that SWPDT systems could be a beneficial solution for these controls, as all communications are carried out through the power coils, without added wireless data technologies that could be even manipulated maliciously. The use of SWPDT systems for maximum efficiency control is conditioned by communication parameters, such as DR or bandwidth, which must be studied and properly designed in order to meet all requirements.

B. Synchronization Between Power Converters

As a different specific case study, the use of data transmission between both parts of the circuit is proposed to carry out the synchronization between the primary and secondary power converters [72], [73]. In WPT systems where control over the converters on both sides is implemented [74], it is of substantial importance to synchronize the signals that activate the power converters. This is mandatory to control the power flows in vehicle-to-grid (V2G) operations based on a phase-delay technique [75]. In this type of approach, the activation of the signals to switch the power devices on the secondary side is delayed with respect to the primary converter. The computation of the delay, referred to as the δ parameter, is usually carried out on the primary side and transmitted to the secondary side. Although there are commercial communication platforms that could be used for the transmission of this parameter, the communication delay is variable due to the uncertain number of phases required for the transmission (initial setup, pairing, and so on). When using these platforms, the system is forced to incorporate complex synchronization techniques like the ones described in [76]. SWPDT could avoid the need for synchronization techniques as the control designer could set the sequence of the communication phases in such a way that the communication latency can be precisely estimated on the secondary side. With an accurate determination of the communication latency, the two power converters can be synchronized so that the V2G operations can be accomplished correctly.

TABLE III
OCPP 2.0.1 AND ISO 15118 MESSAGES' EXAMPLES

	Message	Communication	Content
	ChargeParameterDiscovery.req	EV to EVSE	Contains the amount of energy needed by EV for a full charge.
ISO 18118	PowerDelivery.req	EV to EVSE	Includes the "Ready to charge" state.
	CertificateInstallation.res	EVSE to EV	Installs a new certificate from the CSMS in the EV.
	PaymentDetails.req	EV to EVSE	Provides the certificate chain necessary to verify the signature.
	Authorize.req	EVSE to Central System	User identifier that needs to be authorized
OCPP 2.0.1	BootNotification.req	EVSE to Central System	Includes, at a minimum, the ChargePoint vendor and model identifier.
	CancelReservation.req	Central System to EVSE	Contains the Id of the reservation to cancel.
	MeterValues.req	EVSE to Central System	Contains the amount of energy needed by the EV, a definition of the EVSE and the information about the connector to which the EV is connected.

C. Dynamic Charging

Dynamic charging or charging on-move is a line of research where integration of SWPDT systems can potentially lead to a significant improvement in the charging process. As can be seen from recent references, dynamic charging has been a topic of interest in the scientific community in recent years [77], [78], [79], [80]. In dynamic wireless charging systems, data transmission from/to the primary circuit to the secondary circuit is required in the same way as in static charging. However, in the case of dynamic charging, this communication must be even more robust and fast as the vehicle is constantly in motion. For this reason, in order to avoid connection losses, data loss, delays, or inaccuracy, in dynamic charging systems, the data acquisition is generally carried out at the beginning of the charging line [81]. This forces the system to deduce the battery status, the mutual inductance, or the state of constant voltage/constant current, while it moves over the line of transmitting coils. This deduction can be inaccurate or even wrong. Thus, we consider that SWPDT systems with simple communication protocols can provide a clear alternative to commercial communication systems so that constant communication can be maintained during the entire charging process without the need for a repetitive pairing process.

D. EV Dispatching Strategies

Finally, a fourth case study that is gaining relevance should be mentioned: EV dispatching strategies. Power grids are experiencing an increase in power consumption in recent years, and with the arrival and expansion of EVs, it is estimated that this consumption will increase by a further 15.98% by 2050 [82]. The problem is aggravated by the fact that the majority of EV users charge their vehicles when they return home from work, resulting in peak demand in more limited time slots.

On the other hand, bidirectional charging of EVs has been gaining in popularity in recent years, with technologies such as V2G or vehicle-to-home (V2H). These technologies can decongest the power grid as the batteries of the EV can be used as a source of energy in times of high-power demand. In addition, these EV batteries can be recharged following constraints such as the price of electricity or the state of charge of the EV batteries. All these processes can be performed

by means of charging planning algorithms that allow optimal energy management at any given moment.

For the development of these algorithms, communication between the EV and the charging station is essential. However, the implementation and integration of EVs with wireless charging in the market generate the need to establish new types of communication so that these systems also participate in the energy management algorithms. Thus, we believe that SWPDT systems can be an optimal solution for this application.

IV. OCPP PROTOCOL

As mentioned in Section I, one of the most widely used protocols for information exchange in the EV charging process is the OCPP protocol. The OCPP protocol is designed to allow charging points and management systems to be manufacturer-independent and, thus, to achieve universal information exchange between the charging point and the central system. There are several versions such as OCPP 1.0 [83], OCPP 1.6, and OCPP 2.0.1. The most widely used is OCPP 1.6 [84], while OCPP 2.0.1 [85] is the most recent. The OCPP 2.0.1 specification supports the use of the ISO 15118 standard for communication between the charging station and the EV. This standard regulates the physical data link, network, and application layer requirements. It also defines the requirements for wireless communication at the physical data link, network, and application layers. Thus, EV wireless chargers are also expected to operate with this protocol, as illustrated in Fig. 5. Wireless chargers and their communication system in particular must be adapted to these requirements in order to be fully compatible with these protocols. In this article, we want to provide an analysis of the feasibility of this protocol for wireless charging of EVs. The basic concepts are outlined in the following.

In its new version, the OCPP 2.0.1 protocol has two new important features. First, it has the possibility to establish a bidirectional power flow, including V2G transmission, by using ISO 15118 protocol [86]. It is necessary to consider this feature in order to determine if bidirectional communication is also needed.

Second, OCPP version 2.0.1 together with ISO 15118 allows the EV to make a request with the amount of energy required until it is fully charged, in kWh, as can be seen in Fig. 6. This message is transmitted from the secondary

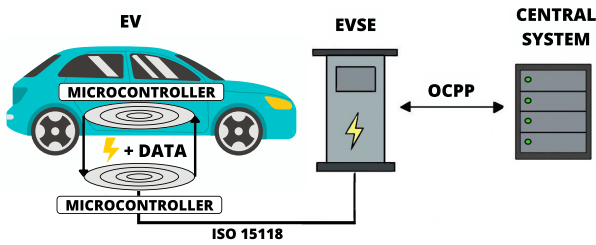

Fig. 5. Diagram of the integration of OCPP ISO into an inductive charger.

circuit of the WPT system to the EVSE. The EVSE transmits this information to the Central System, which can then draw up a charging plan based on requests from the other vehicles. The OCPP specification, based on ISO 15118, describes this process as “charging with load leveling based on high-level communication.” All actions consist of the same structure, divided into two parts: a request and a confirmation. In each of these parts, variables of different types are sent (some mandatory, others optional) containing information about the action to be carried out. An example of these messages (among others), taken from [85] and [87], can be seen in Table III.

If EV wireless chargers are operated with the OCPP protocol together with ISO 15118, while the EV battery is being charged, the exchange of messages includes messages not only between the EVSE and the CSMS but also between the primary and secondary sides of the EV WPT system. Vehicle identification, energy demand, battery status, or warning messages need to be transmitted between the primary and secondary sides (in both directions when we include the receipt confirmation). For this reason, it is important to design and implement a robust and secure communication system between both sides for wireless chargers. This minimizes the loss of messages due to connection errors, following a bidirectional communication protocol compatible with the one implemented in EV conductive chargers.

A review of the regulations governing the OCPP protocol, as well as the ISO 15118 standard, reveals numerous requirements for the communication channel that an EV charging system must satisfy. It should be noted that these requirements are established for plug-in charging but can be considered a reference for wireless charging implementations.

According to both ISO 15118 part 2 [87] and the OCPP 2.0.1 protocol, messages sent between the EV and the charging station, as well as between the charging station and the central management system, must have the ability to be transmitted in both directions. For example, if an EV makes a request to the charging station through a message in the “Request” mode, the charging station must reply to the EV with a message in the “Response” mode. This means that the communication between all parts of the system must be bidirectional.

ISO 15118-2 also sets some specific restrictions for each message, such as session time parameter values and message structure definition, where the maximum duration (in ms) and the content of the message (semantics and type definition) are specified, as we will describe in more detail in Sections VI and VII.

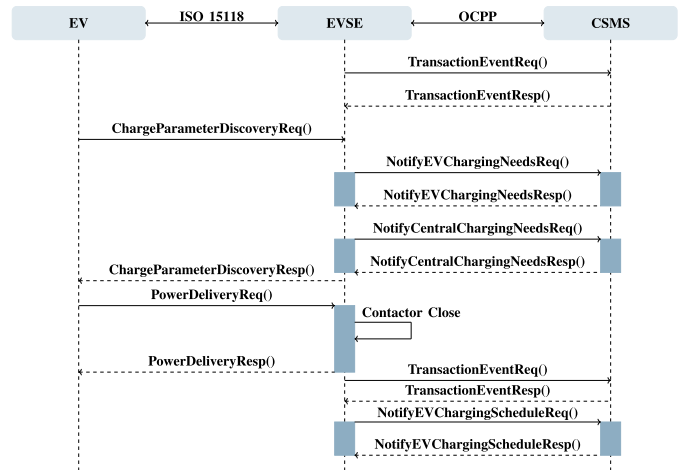

Fig. 6. OCPP and ISO 15118 communication sequence example.

V. SWPDT FOR EV CHARGERS: CLASSIFICATION

This article reviews a significant number of research works on the design of SWPDT systems published in recent years. They can be classified into different categories according to different criteria. The purpose of this classification is to group all systems with similar characteristics to obtain an overview of the criteria used when designing a system. Their advantages and disadvantages are considered, as well as their compatibility according to the application for which they are intended. The following criteria, as summarized in Fig. 7, are proposed for the classification.

- 1) *Number of Links and Number of Signal Carriers*: In WPT systems, a pair of coupled coils is defined as a wireless link. The transmission of power and data can be made over one link only [single link (SL)], or they can rely on two pairs of coils for the separate propagation of the power and the information [double link (DL)]. As for the frequency of the transmission, data and power can share the same carrier (single carrier (SC) schemes), or they can be transmitted with different frequencies [dual carrier (DC)]. The same classification has been proposed in [36].
- 2) *Data Communication Type*: Depending on the direction of the data transfer and the simultaneity of both directions, three categories can be distinguished:
 - a) simplex, where a data signal can only be transmitted in one direction (from the primary side to the secondary side or from the secondary side to the primary side);
 - b) half-duplex, where a data signal can be transmitted in both directions, but not simultaneously (from the primary side to the secondary side and from the secondary side to the primary side at different times);
 - c) full-duplex, where a data signal can be transmitted simultaneously in both directions (from the primary side to the secondary side and from the secondary side to the primary side at the same time).

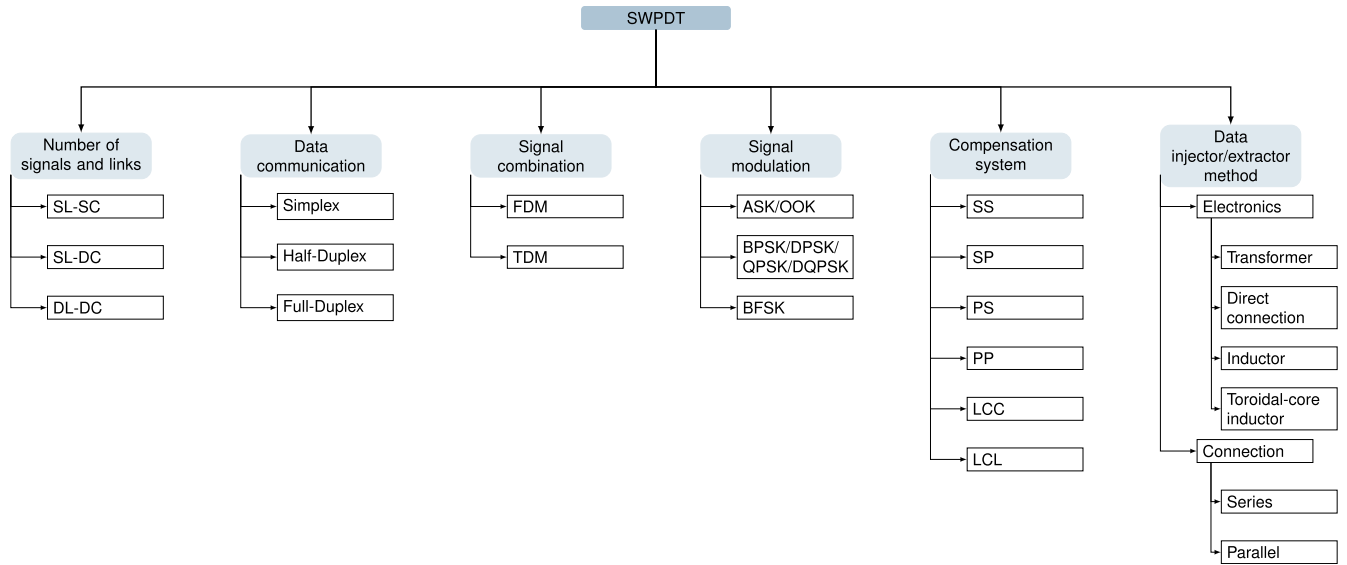

Fig. 7. SWPDT classification scheme.

Both half-duplex and full-duplex are bidirectional communications, while simplex is a unidirectional communication.

- 3) *Signals Multiplexing Technique*: When two different signals coexist in the same circuit as in our application for power and data, there are different multiplexing techniques that allow them to be transmitted simultaneously, such as the following.

- a) *Frequency-Division Multiplexing (FDM)*: Two (or more) different frequencies are used within the available bandwidth for transmitting two signals.
- b) *Time-Division Multiplexing (TDM)*: Two (or more) signals are transmitted in different time slots, following an alternating pattern, using (or not) the same frequency within the available bandwidth.

- 4) *Modulation of Data Signal*: The data transmitted by the circuit can be modulated in the following ways.

- a) *Modulation With Amplitude Variation*: Amplitude shift keying (ASK) and ON-OFF keying (OOK).
- b) *Modulation With Phase Variation*: Binary phase shift keying (BPSK), differential phase shift keying (DPSK), quadrature phase shift keying (QPSK), and differential QPSK (DQPSK).
- c) *Modulation With Frequency Variation*: Binary frequency shift keying (BFSK).

- 5) *Data Injection/Extraction*: Depending on the technique used to inject or extract the data, different methods can be distinguished according to two categories.

- a) *Depending on the Electronics Used*: Transformers, inductors, direct connection, or toroidal-core inductor.
- b) *Depending on the Injector/Extractor Circuit Connection to the Power Electronics*: Series or parallel.

- 6) *Compensation System*: As indicated in Section II, different compensation systems may be used, such as SS, SP, PS, PP, and LCC. To determine the appropriate

compensation system for the design, the bandwidth tolerance to misalignment must be taken into account, as this is a factor that varies according to the chosen compensation system.

Considering these criteria, Sections V–X describe the main particularities of SWPDT systems for each criterion identified.

VI. NUMBER OF SIGNALS AND LINKS

Existing SWPDT solutions can be classified into the following categories according to the number of links and signals, as indicated in [37]: SL-SC, DL-DC, and SL-DC. It should be noted that the DL-SC configuration is not practical and is more expensive and complicated than the SL-SC configuration. Therefore, the DL-SC configuration will not be discussed in this article.

In the following, we develop the characteristics of each of these configurations in more detail.

A. SL-SC Configuration

In the SL-SC configuration, a single pair of coupled coils is used for both the data and power transmission. This can be achieved in two main ways. In one method, power is transmitted at a preset frequency (f_p), but the amplitude of the power varies according to the data signal. In another method, the power amplitude remains constant, while the frequency of the power transmission varies between two different values (f_{p1} and f_{p2}). It can be observed that power transmission is affected by data transmission; therefore, the power level to charge the EV batteries is affected by the data transfer and could lead to longer charging times (CTs). The communication direction depends on the structure of the power converters. Thus, for a unidirectional wireless charger with this scheme, data can only be transmitted from the primary side to the secondary side. V2G chargers will allow communication in both directions if the signal generators are installed on both the primary and secondary sides. A generic representation of this type of SWPDT system is shown in Fig. 8.

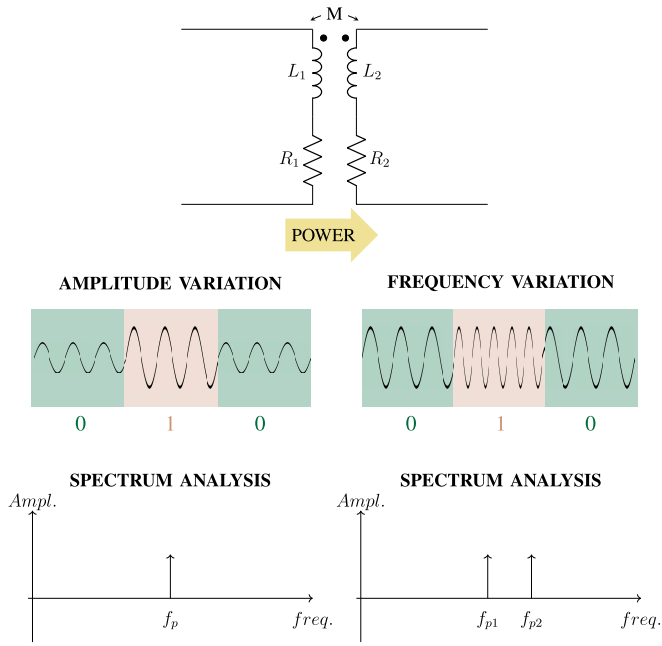

Fig. 8. SL-SC scheme.

The SL-SC configuration has a number of disadvantages that need to be taken into account. In general, the power signal is modified in order to transmit data from one side of the circuit to the other. This modification can be made by varying either the amplitude or the frequency of the signal. Although this is a simple way of transmitting data since it takes advantage of a signal already transmitted in the circuit, these actions trigger a series of disadvantages that should not be overlooked. For example, if ASK modulation is used for the power signal, the power transmitted to the load varies with each bit of the transmitted data. This means that the power generated is constantly being reduced or increased, which directly affects the vehicle's CT: the lower the transmitted power, the longer the total CT. In addition, this can affect the battery lifetime, as it does not charge at a constant voltage and current—as mentioned in Section I—but oscillates between at least two values constantly, with burst. This may damage the battery since it should be charged at an accurate and constant current/voltage through stable conditions [88]. Another case involves modifying the power signal through a frequency variation. The major drawback here is that the circuit will stop working resonantly at every variation of the power signal frequency, resulting in low overall system efficiency. To overcome these problems, adjustable compensation systems need to be included, which makes this option more expensive and complex.

Different solutions proposed with this type of configuration can be observed in [89], [90], [91], and [92], where data are transmitted by means of a power amplitude variation, and in [66], [93], [94], and [95], where power frequency variation is the chosen method.

A further problem caused by these circuits is that the DR is low since the bandwidth is limited by the frequency of the power carrier wave (standards on EV wireless chargers

limit the frequency of operation to the range of 79–90 kHz), which, in turn, is hampered by the physical limitations of the power semiconductors. For example, the more the amplitude of the signal is reduced, the more significant the semiconductor nonidealities are, i.e., a voltage drop of 0.7 V produced by a diode at 100 V is more relevant than at 300 V. This effect will have a repercussion in the power transfer efficiency.

Furthermore, in SL-SC systems there is a direct relationship between the vehicle CT and the DR during transmission. As mentioned in Section III, a series of messages are transmitted during the charging process of the EV, at a given DR, to allow an exchange of information between all parts of the system. These coded messages can be understood as a given number of “0” and “1.” In an SL-SC system, if the transmission of a bit can alter the frequency or amplitude of the output voltage or current, it results in a change in the vehicle CT. For example, if it is assumed that, when transmitting a “1,” the voltage remains constant, and when transmitting a “0,” the voltage decreases by a certain value, this decrease will result in a longer CT δ_τ since the output power will then be lower. To understand the relationship between CT and DR, the number “1” sent will be denoted as m_d and the number “0” as n_d , and the time when a bit is transmitted will be denoted as τ_d . It is expected that data communication is necessary only during some slots in the charging process. Thus, there will be some periods when no data transfer is required. In SL-SC SWPT systems, it is mandatory to include a preamble data sequence to indicate that the communication has started. Otherwise, the receiver assumes that the transmitter is always sending a “1” bit. This preamble will contain a sequence of “1” and “0” bits to activate the data processing. Similarly, there will be a sequence to indicate that the data transfer has ended. Assuming that the number of “0” bits in the preamble and the ending sequence are n_p and n_e , respectively, and the time to send 1 bit is τ_p in the preamble and τ_e in the ending message, the resulting CT for an SL-SC system (CT_{SL-SC}) is computed as

$$CT_{SLSC} = CT_{WPT} + M(n_p\tau_p + n_e\tau_e) + n_d\tau_d \quad (1)$$

where CT_{WPT} corresponds to the CT required by a conventional WPT system and M is the number of data sequences during the charging process.

From (1), it can be deduced that the higher the number of bits “0,” the longer the CT in SL-SC systems.

Finally, the charging efficiency may be reduced. In the case of SL-SC amplitude variation, as mentioned before, output power may be lower when a “0” is transmitted. If we consider overall efficiency, as indicated in (2), it can be deduced that its value will constantly change during data transmission and will be lower when a “0” is transmitted. The loss of efficiency for a transmission of a “0” is caused by the nonidealities of the power converters, which are more relevant for low-power voltages

$$\eta = \frac{CT_{SLSC} - CT_{IPT}}{CT_{SLSC}}\eta_0 + \frac{CT_{IPT}}{CT_{SLSC}}\eta_1. \quad (2)$$

In a similar way, the SL-SC approach based on frequency variation also requires a preamble and an ending sequence to

be included, which will increase the CT. When a frequency variation is performed, the WPT system does not usually work in resonance for both, so the efficiency will be lower when the operational frequency is different from the resonant frequency. The CT will increase as a result.

Finally, it should be highlighted that, although this technology requires the power signal to be modified to perform the data transmission, the initial stages of the communication, such as the handshaking process, can be correctly carried out without initiating the power transmission. An example of the correct functioning of this process can be found in [89].

B. DL-DC Configuration

In the DL-DC configuration, two or more frequencies are used for the wireless data and power transmission (f_d and f_p , respectively), which are carried on two or more channels. An extra pair of coupled coils (L_{D1} and L_{D2} with their internal resistances R_{D1} and R_{D2}), with extra control electronics, are added to the circuit to transmit the data signal, which increases the cost and size of the system. Power and data are transmitted at the same time through the different links, so there is no change in the CT with data or without them. An example of this type of system is shown in Fig. 9. The close proximity of the data and power coils may cause interference between the two links at the same time, as there will be a slight coupling between them (represented by the mutual inductances M_{DP1} and M_{DP2}). Generally, in DL-DC systems, the data signal has a higher frequency than the power signal, as shown in the spectrum analysis. In addition, the data are sent with a lower amplitude. An example of this type of configuration can be found in [96] or [97].

Although, in this configuration, the power signal is not modified, and in theory, signals are not transmitted together on the same channel, the main disadvantage is the cost of the system since a new pair of external coupled coils is needed, with extra electronics. This increases the price. It must also be remembered that including an external element increases the size of the overall system, which can be a disadvantage considering that part of the system is installed in a mobile element (EV). Another problem to be solved is the position between the power-coupled coils and the data-coupled coils, as it would be necessary to deal with the possible currents induced between them due to the coupling between the power and the data coils. It is preferable to minimize M_{DP1} and M_{DP2} . If these two parameters are not negligible, there will be a high-frequency signal in the power link, and the data signal cannot be decoded correctly. The data signal would also generate extra consumption in the power converters. Filters are usually necessary to prevent these effects since it is not possible to ensure that the coupling M is not null. Considering this circumstance, the data frequency is not usually a third harmonic of the power signal to prevent the harmonics due to the power circuit from being understood as data.

Finally, it is worth noting that one of the problems to contend with in wireless EV charging is potential misalignment between the coils during vehicle charging since, even though the charge is static, there is a high probability that the vehicle's

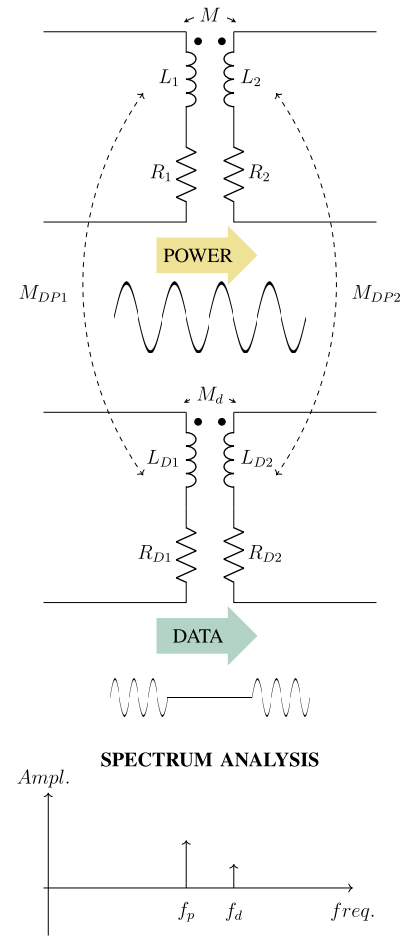

Fig. 9. DL-DC scheme.

coil is not perfectly aligned with the coil on the charging platform. The positioning between the coils is a key point in determining CT and efficiency. Therefore, if, in addition to the power coils, new coils are added in both primary and secondary for data transmission, not only misalignment between the power coils but also misalignment in the data coils must be taken into account, which would complicate this method.

In addition, data coils are generally smaller in size than power coils, as the amplitude of the data signal transmitted is lower (the data signal typically has an amplitude of between 5 and 15 V, as opposed to 230 V for the power signal) and the frequency is higher. For example, in [96] and [97], the power coils have an area of $100 \times 100 \text{ mm}^2$, while the data coils have dimensions of 60×60 and $80 \times 80 \text{ mm}^2$, respectively. The smaller the area of the coils, the greater the effect of misalignment between them. Fig. 10 illustrates the reason for this: for the same displacement on one x -axis (δ_x), the smaller the area, the lower the flux received by the secondary circuit, since the area that remains parallel between the two coils (S) is smaller. The relationship between magnetic flux and surface area can be seen in (3), in which Φ is the magnetic flux, B is the magnetic field, and S is the evaluated surface. In turn, the voltage induced in the secondary circuit (e_{ind}) depends on the flux variation and is determined by Faraday's law (3), from

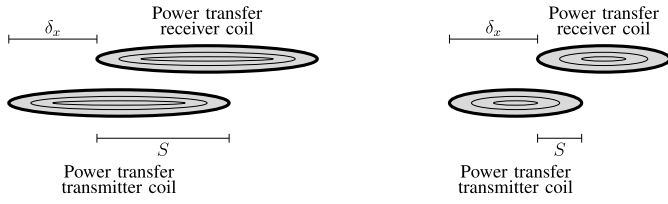

Fig. 10. Misalignment effect between two different pairs of coils.

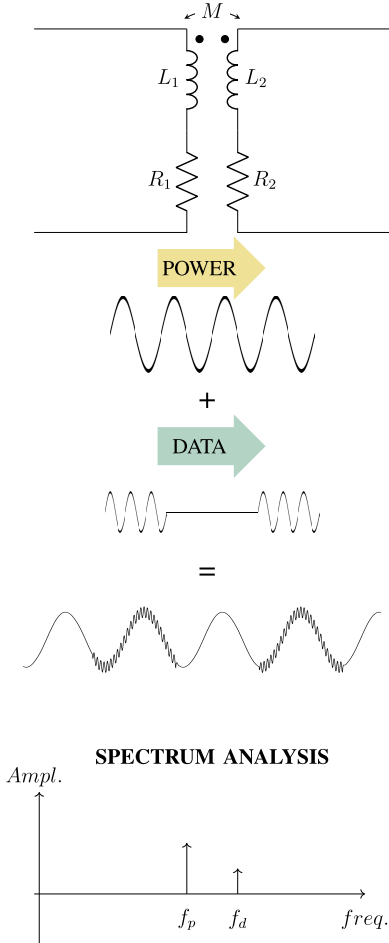

Fig. 11. SL-DC scheme.

which it can be extrapolated that the lower the variation of the flux, the lower the induced voltage

$$e_{\text{ind}} = -\frac{d\Phi}{dt} = -\frac{d}{dt} \int_S B_n dA. \quad (3)$$

C. SL-DC Configuration

In this configuration, two or more frequencies are used for the data and power transmission (f_d and f_p , respectively), which are carried on a single channel, as shown in Fig. 11. In order to implement this type of circuit, two coils or transformers are generally coupled in the primary and secondary power circuits, which will inject and extract the corresponding data signal from the communication processors. It should be noted that the amplitude of the data signal must be significantly lower than the one used for the power signal.

Among all the proposals, this approach is one of the most flexible and widely used, considering that it incorporates the advantages of the two previous configurations. On this occasion, as can be seen in [28], [37], [98], [99], [100], [101], [102], [103], [104], [105], [106], [107], [108], [109], [110], [111], [112], [113], [114], [115], and [116], the authors choose to use two different signals, one for data and the other for power, which are transmitted on the same channel but are independently controlled.

Although it is the most flexible, the SL-DC configuration introduces a number of disadvantages that cannot be ignored. The first of these is the appearance of circulating currents caused by the inclusion in the circuit of new coils or transformers used to transmit the data signal. Circulating currents are currents generated by connecting transformers in parallel whose open-circuit voltages are not equal. This voltage difference results in a current that is independent of the load, which flows through the transformers. As the circulating currents are not used to supply any load, extra losses occur in the system, thus reducing its efficiency [117]. Second, it must be taken into account that both signals will be transmitted together through the circuit (usually at different frequencies), so there may be interferences between them, causing variations in their characteristics. Generally, these cases require the use of filters that can behave as an open or short circuit at a certain frequency to prevent harmonics in the power signal from affecting the data signal. They are also necessary to prevent the data signal from flowing into the power electronics and hindering the circuit's operation.

It should be noted that, in a WPT system, the semiconductors generate some ripple in the output signal. Depending on the value this ripple reaches, it can have an adverse effect on the communication between the two sides of the circuit. In other words, if the ripple has an amplitude and frequency value greater than or equal to the data signal, the transmitted data wave will be modified unintentionally if nothing is done to prevent it. This could result in the data being processed incorrectly.

D. Analysis of the System Design Criteria

In the classification of these configurations given in Sections VI-A–VI-C, we can observe that there is a significant differentiation between the design criteria of each of them. We will now analyze the following criteria: frequency, DR, electronics, and crosstalk minimization.

When designing an SWPDT system, it is crucial to choose the correct working **frequency** (both for power and data transmission), which will generally be one for SL-SC systems and two or more for SL-DC and DL-DC systems. The latter requires at least one signal for power transmission and one different signal for data transmission. In addition, if the data transmission is full-duplex, a different data channel may be required for each direction, one from the primary side to the secondary side and a different one from the secondary side to the primary side.

Regarding the frequency for the power carrier signal, there is no fixed frequency among the solutions presented so far, as the

TABLE IV
SUMMARY OF FREQUENCIES AND DR USED IN THE MAIN SWPDT SYSTEMS

Number of Links and Signals	f_p	f_d	Data rate	Ref.
SL-SC	22 kHz	<i>Not specified</i>	<i>Not specified</i>	[93]
	100 kHz	100 kHz	25 kbps and 50 kbps	[91]
	83 kHz	83 kHz	<i>Not specified</i>	[89]
	85 kHz and 87 kHz	85 kHz and 87 kHz	2 kbps	[94]
	85 kHz	85 kHz	<i>Not specified</i>	[66]
	85 kHz and 83 kHz	85 kHz and 83 kHz	1 kbps	[95]
	100 kHz	100 kHz	100 kbps	[92]
	100 kHz	100 kHz	<i>Not specified</i>	[90]
SL-DC	85kHz	5 MHz and 6.25 MHz	64 kbps	[98]
	22.4 kHz	13.56 MHz and 6.78 MHz	<i>Not specified</i>	[99]
	150 kHz	8 kHz	1 kbps	[100]
	100 kHz	8 kHz	1 kbps	[101]
	85 kHz	3 MHz	40 kbps	[102]
	85 kHz	2 MHz and 1.2 MHz	80 kbps	[103]
	85 kHz	5.5 MHz and 4.5 MHz	500 kbps	[104]
	22.4 kHz	1.67 MHz	20 kbps	[28]
	80 kHz	10.7 MHz	80 kbps	[105]
	85 kHz	2 MHz	<i>Not specified</i>	[37]
	85 kHz	5 MHz	<i>Not specified</i>	[106]
	85 kHz	850 kHz	28.33 kbps	[107]
	85 kHz	1.65 MHz and 1.5 MHz	150 kbps	[108]
	85 kHz	1 MHz	166.7 kbps	[109]
	28 kHz	756 kHz	5 kbps forward and 10 kbps backward	[110]
	28.3 kHz	1.67 MHz	<i>Not specified</i>	[111]
	50 kHz	2 MHz	10 kbps forward and 200 kbps backward	[112]
	91 kHz	10 MHz	560 kbps	[113]
	100 kHz	1.9 MHz and 3.2 MHz	600 kbps	[114]
	100 kHz	1.4 MHz and 4.2 MHz	200 kbps	[115]
85 kHz	2 MHz and 1.2 MHz	250 kbps forward and 170 kbps backward	[116]	
DL-DC	200 kHz	6 MHz	19.2 kbps	[96]
	200 kHz	6 MHz	19.2 kbps	[97]

authors propose different values ranging from 22 to 200 kHz. According to the SAE J2954 standard, the contemplated frequency range for power transmission is from 79 to 90 kHz.

The situation is similar for the data signal, except that, in this case, most authors use frequencies at least one order of magnitude higher than the power signal, in the order of megahertz (MHz). However, to avoid any potential interferences between the data signal and the power signal harmonics, some authors argue that, for the data signal, it is more appropriate to use a frequency lower than the power signal [100], [101]. This introduces a disadvantage: the data transmission rate is lower than that achieved with higher frequencies, as can be seen in Table IV, so it would clearly limit a system that requires an exchange of information with a high transmission rate.

It should be noted that, in SL-DC configurations, the data carrier signal is transmitted through the main coils, together with the power signal that is modeled as the first harmonic of the primary converters' output voltage. However, odd harmonics are also present in the circuit. Therefore, when choosing the frequency of the data carrier signal, it would be good practice to avoid choosing values close to these odd harmonics of the power carrier signal.

A summary of the frequencies used for each configuration, as well as the data transmission rate achieved in each case, can be found in Table IV. It should be noted that the resonant working frequency is named f_p , and the frequency of the data signal is named f_d .

In some cases, we observe two different DRs for data transmission: one for forward information and another for backward information, as described in [110] and [112]. In the solutions reviewed, the data transmission circuit design differs according to the communication direction, resulting in an asymmetric data system. However, the communication system used in [91] is the same, but the DR is different because the fluctuation of the primary current is smaller than that of the secondary current.

The DR is an important parameter in the system design since, among other determinants, the communication protocol will establish minimum time requirements that must be complied with during a sequence of messages. As mentioned in Section IV, one of the most widespread protocols in EV charging is OCPP, working together with ISO 15118. For this reason, and as a representative example, we will now examine some of the V2G messages that can be transmitted in a communication sequence, as shown in Table V, in order to

TABLE V
REPRESENTATIVE EXAMPLE OF ISO 15118 MESSAGES' DRs

MESSAGE	Bytes	Bits	Time (s)	Minimum data rate (bps)
ServiceDiscoveryReq	70	560	2	280
PaymentsDetailsReq	1616	12928	5	2586
CurrentDemandReq	207	1658	0.25	6632
CertificateInstallationRes	3289	26312	4.5	5848
ChargingStatusRes	260	2084	1.5	1390

determine whether the systems analyzed can be implemented with the aforementioned protocol.

We counted the maximum number of bytes required to transmit each of the messages. We reviewed the bytes considering the structure of each of the constituent elements, taking into account different formats that can be found in the literature. When performing the count, we considered the data type, such as short, unsigned long, string, and Boolean; ISO 15118 lists the structure of the messages, with a description of their constituent elements and, in some cases, their maximum length. The analysis that we performed was based on an approximate determination of the maximum number of bits to be transmitted in each message. In order to illustrate the methodology used, we will disaggregate one of the messages as an example. In the case of *ServiceDiscoveryReq*, the message has two main elements: *ServiceScope* and *ServiceCategoryType*, both of string type. For the former, the ISO standard states that its maximum length is 32 bytes, while, for the *ServiceCategoryType* element, the types of messages that can be sent are defined. In order to analyze the maximum length that can be included in this element, we examined the message with the largest number of characters. In this case, this message is “ContractCertificate,” which is composed of 19 characters. It should be noted that UTF-8 encoding is employed so that each of the characters can be encoded in 2 bytes, giving a total of 38 bytes. The resulting number of transmitted bytes will, therefore, be 70 bytes. We performed a similar analysis for the rest of the messages in Table V. Furthermore, the ISO 15118-2 standard defines the maximum time taken for each of the V2G messages transmitted. This requirement is included in the “Time” column. Considering the total number of bits, the minimum DR can be determined for the individual cases.

Analyzing the results in Table V, it can be seen that, while some messages have a DR of approximately 280 b/s, in other cases, DRs can be higher than 6 kb/s. As a result, it can be deduced that systems whose communication has a DR lower than these values (such as 1 or 2 kb/s) are not suitable for using the OCPP-ISO 15118 protocol since they would not comply with the minimum time requirements imposed by the standard.

With regard to the **electronics** used, it should be noted that SL-DC designs require a higher number of components than SL-SC configurations, such as control circuitry, signal generators, and complex demodulator circuits. This is because, if two or more signals of different frequencies are transmitted, then, generally speaking, each signal must be controlled and

generated independently. Moreover, a coupled coil or transformer needs to be included to inject and extract the data into the power circuit (as described in Section X). For SL-SC cases, as can be seen in the articles that we reviewed, the control circuit of the power electronics is the one that controls and generates the data transmitted by the circuit. If, as well as having two different signals, a separate channel is used for each of them, as in the case of DL-DC, there is an increase in both the number of components used and their cost. One of the factors that determine the cost of the system is the type of material used for data transmission coils in DL-DC solutions. In the cases that we reviewed, the material used to manufacture the coils is Litz wire, which, despite its advantages in terms of reducing eddy current losses, increases the cost of the system.

In the same way, it is important to address **crosstalk minimization** design criteria in the various configurations proposed. Crosstalk is a phenomenon that occurs when a signal creates unwanted effects in a different channel [118]. The crosstalk effect must be minimized in an SWPDT system, where power and data are transmitted. In [36], different design solutions are, therefore, proposed to reduce crosstalk, according to each signal-link classification. In SL-SC, the authors suggest modulation and compensation topology optimization, and closed-loop control, in order to achieve constant output characteristics during power modulation. On the other hand, in SL-DC systems, they recommend isolation between power and data loops, adding wave trappers to trap inductors and power transfer gain maximization, which can be achieved through adaptive frequency control or maximum power point tracking. Finally, for DL-DC configurations, where crosstalk is the result of cross-coupling between both pairs of coils (power and data); the authors propose to carefully adjust the position between the power and data coils until cross-coupling is reduced to zero. Multiple data coils could also be used to make the sum of induced magnetic flux null. The design is not trivial, however.

Finally, there is a noteworthy design criterion that can be decisive in an SWPDT system: **coil geometry**. Thus, the choice of topology must be made on the basis of the behavior of the coil under different misalignments. That is, if, in the final application for which the designed system is intended, there is a high probability that both coils will be misaligned during the charging process, a geometry robust to this factor, such as DDQ, should be chosen. However, if in the charging process there is no possibility of both coils being misaligned, a circular or rectangular (unipolar) geometry could be chosen, considering, in turn, that the rectangular geometry has a higher tolerance than the circular geometry. It is important to determine this criterion according to the target application of the SWPDT system, as the choice of coil geometry can influence the cost, material used, and weight of the final prototype.

Table VI provides a brief summary of the recommendations discussed in this section.

VII. DATA COMMUNICATION TYPE

As in a conventional communication system, the data links can be classified as simplex, half-duplex, and full-duplex. The

TABLE VI
SUMMARY OF DESIGN RECOMMENDATIONS

Parameter	Recommendations
Power working frequency	From 79 to 90 kHz, according to SAE J2954 standard.
Data signal	Data signal frequency recommended to be an order of magnitude higher than power signal frequency. Choose frequencies that differ from power signal harmonics.
Data rate	Must satisfy the minimum time requirements established by the communication protocol used.
Electronics used	For the system design, the advantages and disadvantages of each configuration must be considered, as well as the number of components required, the number of signals, and the costs.
Crosstalk minimization	SL-SC: modulation, compensation topology optimization and closed loop control are suggested. SL-DC: isolation between power and data loops and power transfer gain maximization are recommended. DL-DC: careful adjustment of the position between the power and data coils, and multiple data coils for magnetic flux reduction are advised.
Coil geometry	Circular coils have poor misalignment tolerance, while DDQ coils have the best performance. Rectangular coils have better misalignment tolerance than circular coils. The choice of the coil geometry must be made according to the intended application of the final charging prototype.

simplest communication configuration is *simplex*, in which data are transmitted in one direction only (*unidirectional*). The data transmission can be from the secondary side to the primary side, as can be observed in [66], [92], [96], [97], [101], [111], and [113], or from the primary side to the secondary side, as shown in [90], [102], and [105]. One problem introduced by the simplex configuration is the nonconfirmation of data reception by the receiving circuit. Therefore, the transmitting circuit cannot identify whether or not the message has been received correctly.

Bidirectional communication has more advantages according to many proposed solutions for simultaneous wireless power and data transfer in EVs. In this approach, the primary and secondary coils are used for both transmitting and receiving data. This bidirectional configuration can be further classified into two types.

- 1) *Half-Duplex*: Where data are transmitted in both directions, but not simultaneously, as is the case in [28], [37], [89], [91], [93], [94], [95], [100], [106], [107], [108], [109], and [110].
- 2) *Full-Duplex*: Where data are transmitted simultaneously in both directions, as can be observed in [98], [99], [103], [104], [112], [114], [115], and [116].

Generally, for the half-duplex configuration, the same data generation and demodulation circuit is used on both the primary and secondary sides, achieving similar DRs in both directions. For this purpose, some authors propose to use a selector circuit that changes the direction of communication

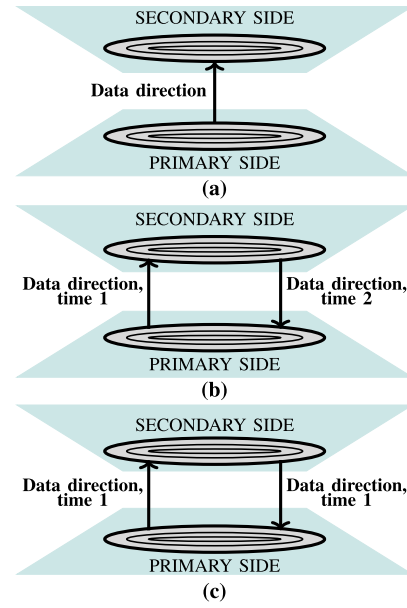

Fig. 12. (a) Simplex, (b) half-duplex, and (c) full-duplex data communications.

TABLE VII
SUMMARY OF TYPES OF COMMUNICATIONS

Type of communication	Ref.
Simplex	[96], [97], [101], [102], [66], [111], [113], [92], [90], [105]
Half-duplex	[93], [91], [89], [100], [28], [37], [106], [94], [107], [95], [108], [109], [110]
Full-duplex	[98], [99], [103], [104], [112], [114], [115], [116]

(forward or backward), as in [28] and [107]. There are specific cases where the authors decide to implement a different data circuit for each direction of communication. This is the case in [110], where even a different type of data modulation is employed, achieving different DRs for backward and forward communications.

The same is true for the full-duplex configuration, where it is most common to use the same data circuit for both directions of communication. When it is not used, as in [112], the DR is different for each direction.

Fig. 12 shows, in a simplified form, the difference between the three types of communications, and Table VII gives a brief summary of works according to this classification.

The type of communication used in a circuit can be a determining factor when choosing the protocol on which the data transmission in the system will be based, as it can impose restrictions that may not allow the protocols to be used. This is true of OCPP together with ISO 15118, which, as briefly mentioned in Section III, uses a specific structure in its message sequences. By using these protocols, bidirectional communication is established between the devices that make up the system. In other words, if a message is sent to request an action or piece of data in the “Request” mode, the device sending the message must receive another message back in the “Response” mode. For this reason, systems that establish

a simplex communication are excluded from using the OCPP protocol in association with ISO 15118, as they can only send messages in a single direction. Thus, it can be concluded that simplex communication cannot be used for applications where bidirectional communication is a requirement, while half-duplex and full-duplex communication can be used in such cases. The advantage of full-duplex over half-duplex is that bidirectional communication has no delays since messages are sent simultaneously in both directions. The main disadvantage is that the bandwidth must be wider for full-duplex than for the other two types of communication. Thus, in applications where bidirectional communication is needed and bandwidth is limited, half-duplex communication is the optimal choice, while, if there are no restrictions on bandwidth, full-duplex communication offers higher speed than bidirectional communication.

VIII. SIGNALS' COMBINATION TYPE

If two different signals need to be transmitted over the same circuit, it is necessary to study how the different signals will be transported through it simultaneously so that they do not significantly interfere with each other. For this purpose, there are several multiplexing techniques, which allow several signals transmitted over the same medium to coexist. FDM and TDM are two of the most commonly used techniques for this type of application.

The FDM technique is used in most of the designs proposed, such as [28], [37], [98], [99], [100], [101], [102], [103], [104], [105], [106], [106], [107], [108], [109], [111], [112], [114], [115], and [116]. The technique allows two carrier signals to be transmitted simultaneously, with the condition that they must have sufficiently distant frequencies [119]. Since, in the case of EV charging, the frequency of the data signal must be far enough away from the frequency of the power signal to avoid interference between them, this is one of the most commonly used solutions.

Other works such as [99] use the TDM technique as a complement to FDM. In this case, while the data signal and power are transmitted through the winding using the FDM technique, the TDM technique is used to achieve full-duplex communication by sending data in both directions. For this purpose, a control circuit is designed that synchronously switches the communication direction, alternating transmissions from the primary side to the secondary side with transmissions from the secondary side to the primary side. The basis of the operation principle of the TDM technique [120] consists of splitting a message into several parts so that each one is sent in a time slot. Two different data signals (from secondary to primary and from primary to secondary), therefore, coexist on the same channel. In the literature that we reviewed, we only found the combination of TDM and FDM for SL-DC systems. For this combination, Afshar et al. [99] describe two operation modes in communication cells: forward mode and backward mode. In order to determine which mode is executed at each moment of time, AND and NAND logic gates are used, so that, when the data-sending mode is configured in one of the communication cells via the control signal, the receiving circuit, formed by an *RLC* filter, is connected in the other cell

TABLE VIII
CLASSIFICATION OF SIGNAL COMBINATION TYPES

Signal combination type	Ref.
FDM	[98], [100], [102], [103], [104], [28], [105], [37], [106], [107], [108], [109], [111], [112], [114], [115], [116]
FDM and TDM	[99]

and vice versa. Control signals must be out of phase to ensure that data transmission is performed at different time intervals.

Table VIII shows the signal combination type used in each of the designs proposed in which at least two data signals have to be transmitted.

Considering the operating principles, we can conclude that the TDM technique is adequate for cases where the bandwidth for data transmission is very limited, as it allows data to be transmitted using the same channel at different time intervals. However, if bandwidth is not a constraint, whereas transmission time is, the optimal solution is to use the FDM technique, where frequency multiplexing allows bidirectional transmission in the same time slot. In the case of EV charging that relies on OCPP and ISO 15118, it is recommended to use the FDM technique since, according to ISO 15118-2, there are minimum time requirements that must be satisfied when transmitting a complete sequence of messages.

IX. DATA MODULATION TYPE

Another important feature of SWPDT systems is the modulation technique used in data transmission. In most cases, the data sent in the communication will be digital signals, which must be converted to analog signals to facilitate their delivery from the primary winding to the secondary winding, and vice versa.

Depending on the design and system characteristics that are proposed, several different modulation techniques can be found in the related literature.

One of the techniques used is ASK [121], which is found in some proposals such as [96], [97], [102], [103], [105], [110], [112], [113], [114], [115], [116]. In this technique, the digital signal coming from the analog-to-digital converter (ADC) is modulated by varying the amplitude of the signal and transported to the primary circuit for demodulation and interpretation. The simplest version of this modulation technique is called OOK. It is used in the designs proposed in [28], [37], [107], [109], and [111], where a logic "1" corresponds to the presence of the signal and a logic "0" corresponds to the absence of the signal. There is another variation of ASK modulation, known as DASK, where data are modulated and demodulated through the amplitude difference of a signal, rather than by the amplitude of the signal itself, as indicated in [90]. ASK schemes can easily be implemented with an SL-SC topology.

Another modulation technique that is differentiated from the previous one is the BPSK technique used by Trautmann et al. [100]. Here, instead of there being four different phases, there are only two possible ones, representing a

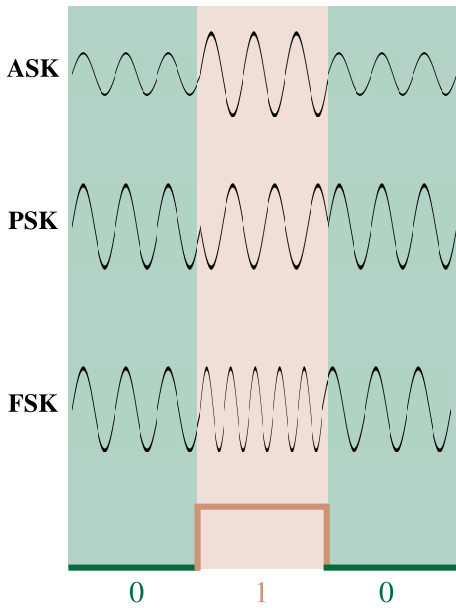

Fig. 13. Illustrative example of ASK, PSK, and FSK modulations.

logic “1” or a logic “0.” Another example where this technique is used is [101].

Sometimes, after a BPSK modulation, the 2-QAM model is used, as proposed in [89]. In this solution, the phase change causes an amplitude change in the voltage drop signal of the primary capacitor (in order to transmit data from the primary side to the secondary side), which results in a “1” or a “0,” depending on the criterion used.

The design proposed in [98] contains a slightly different modulation technique, called DQPSK, which consists of a variation of the phase of the signal, where each phase variation is a different 2-bit symbol. Thus, there are up to four different symbols. This technique increases the DR since the bits are not transmitted individually, but two by two.

The DQPSK technique has a variant, called QPSK, in which it is not the variation between phases that is measured, but rather the phase itself. Therefore, each phase corresponds to a different symbol [122]. The number of symbols is similar to that of the DQPSK technique.

Instead of modifying the amplitude or phase, the frequency of the signal may be modified according to the value of the bit to be modulated. This is a fourth type of modulation known as FSK. In [123], two frequencies are used (leading to a BFSK) where a certain frequency is assigned to a “1” and a different one to a “0.” This type of modulation can be found in [66], [93], [94], [95], [104], [108], and [110], and is one of the most widely used together with ASK modulation.

In Fig. 13, the basic form of each modulation is illustrated, and Table IX shows the modulation used in each of the designs reviewed.

In order to decide which modulation technique is best suited to the circuit characteristics, several factors have to be taken into account. ASK modulation is the simplest, but it is more sensitive to coupling. It is, therefore, likely to be affected by misalignment between the coils, which may hinder the communication process. Furthermore, ASK modulation has

TABLE IX
CLASSIFICATION OF MODULATION TYPES

Modulation type	Ref.
BFSK/FSK	[93], [104], [94], [66], [95], [108]
BPSK	[100], [101]
DPSK	[91]
DQPSK	[98]
2-QAM	[89]
ASK	[96], [102], [103], [105], [110], [112], [113], [114], [115], [116]
OOK	[28], [37], [107], [109], [111]
DASK	[90]
<i>Not specified</i>	[99], [106]

larger cochannel interference from the fundamental component of the power carrier, which causes the communication channel capacity to degrade [98]. PSK modulation solves this problem, and it has the strongest anti-interference ability, but it needs relatively more complex modulation and demodulation circuits, with hard synchronization between signals. Synchronization in PSK schemes may force the use of longer preamble sequences, so it is recommended for longer messages.

Studies, such as [124], specify that certain compensation systems are more tolerant to misalignment than others. For example, SS and SP systems show good misalignment performance but unstable source behavior, which can be overcome by means of an optimized control circuit. The PS and PP systems behave worse under lateral misalignment, showing a sharp decrease in the transferred power. We can, therefore, conclude that, in a WPT system—and consequently in an SWPDT system—misalignment may alter the system performance by modifying the amplitude and/or phase of the signal during the transmission, whereas it is not altered by the data source. For this reason, it is necessary to study whether the changes introduced by the modulation technique included in the system (amplitude of the power signal, phase modification, and so on) further deteriorate the power transfer efficiency of the circuit under misalignment conditions, depending on the type of compensation scheme employed.

When designing the system, it is extremely important for the data signal to be distinguished even under misalignment conditions for all misalignment distances within the limits set by the SAE J2954 standard. These limits are ± 75 mm for the X -axis and ± 100 mm for the Y -axis. For the Z -axis, it will be specified by the manufacturer. In addition, the control system must take into account the effects of misalignment, so as not to confuse these effects with the data variation. The effects of misalignment include changes in the amplitude and/or phase. Their magnitude strongly depends on the compensation system, so any decision about the modulation technique should take into account the compensation system used in those systems where misalignment may occur.

In contrast, FSK modulation is a more robust modulation technique. It improves the antinoise and antifading performance [108] even with misalignment. It needs two high-frequency signal sources, making the design more complex.

TABLE X
SUMMARY OF DATA INJECTORS AND EXTRACTORS

Used electronics	Connection	Ref.
Transformer	Series	[99], [37], [28], [108], [110], [111], [112], [116]
	Parallel	[100], [102], [104], [107], [109], [112], [114], [115]
Toroidal-core inductor	Series	[98]
Direct connection	Series	[105]
Direct connection and resonant tanks	Parallel	[103]
RLC injector / extractor and Resonant tanks	Series and parallel	[106]

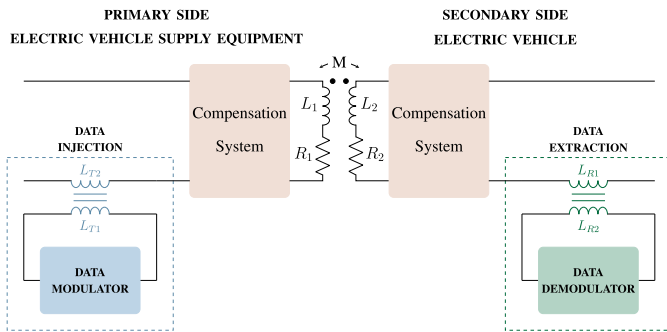

Fig. 14. Transformer-based data injection/extraction.

X. DATA INJECTION/EXTRACTION METHODS

In cases where there are two different signals in the system (SL-DC), the data signal injection and extraction method must be defined. As we have verified after reviewing the different solutions proposed by the authors, there is no single way to perform this task. For this reason, a classification according to two different criteria is given in the following.

- 1) *Depending on the Electronics Used:* Transformers, inductors, a toroidal-core inductor, or a data transfer circuit direct connection.
- 2) *Depending on the Injector/Extractor:* Series or parallel.

Following the first criterion, when we review the data signal injector/extractor electronics, we find that one of the most widely used components is the transformer [28], [37], [99], [100], [102], [104], [107], [108], [109], [110], [111], [112], [114], [115], [116]. This allows the communication circuit and the power circuit to remain isolated from each other. The transformer has smaller dimensions than the main windings and must be carefully designed for each case. This structure can be seen in Fig. 14.

Conversely, Qian et al. [98] propose to replace this transformer with a toroidal-core inductor (as shown in Fig. 15) in order to make the transformer design easier since the power signal needs to flow through the transformer. In this way, the power signal travels through the existing power line, and the data are injected/extracted by the loose coupling between the toroidal inductor and the power line. Another way

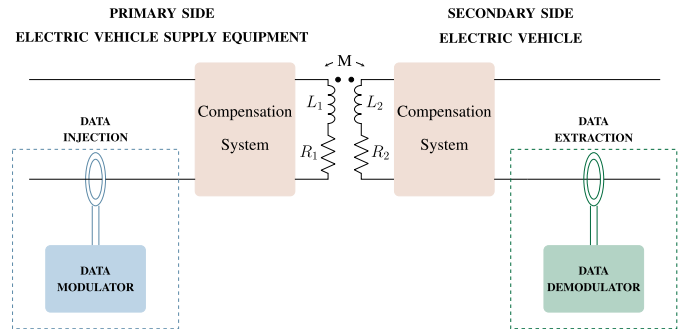

Fig. 15. Toroidal-core inductor-based data injection/extraction.

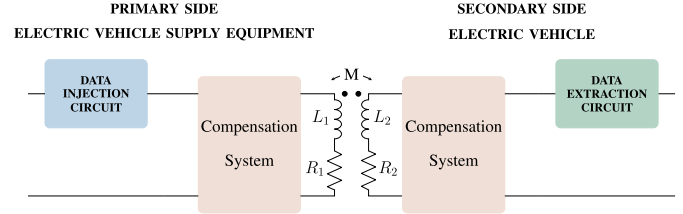

Fig. 16. SS data circuit connection.

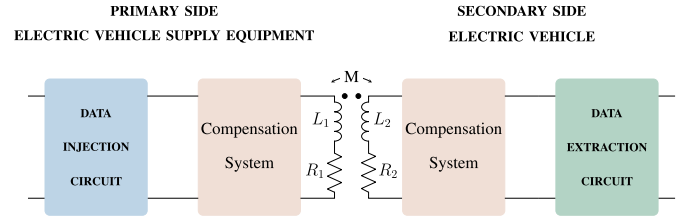

Fig. 17. PP data circuit connection.

to replace the use of the transformer is to employ resonant tanks to optimize the coexistence of both signals through the same channel, along with an extraction/injection RLC circuit, which is connected through the winding terminals to the power circuit, as shown in [106].

Alternatively, Fan et al. [103] and Zheng et al. [105] propose designs that directly connect the communication circuit with the power circuit, accompanied, in the first case, by resonant tanks in parallel.

In order to carry out a second classification, the method of injecting/extracting the data signal must be observed. After reviewing the proposed solutions, we concluded that there is no fixed criterion when determining whether data injection/extraction is carried out through a series or parallel connection. Thus, there are authors who determine that it is more optimal to carry it out in series [28], [37], [98], [99], [104], [105], [116], others who opt for a parallel scheme [100], [102], [103], [104], [107], [109], [114], [115], and, finally, those who differentiate between data injector and extractor, such as [106]. In this last paper, the authors propose to make different connections in each case, keeping the injection of the data signal in parallel and the extraction in series. These three types of implementations reviewed are shown in Figs. 16–18, respectively.

This classification, based on these two criteria, is shown in Table X to facilitate comparison. The first criterion that

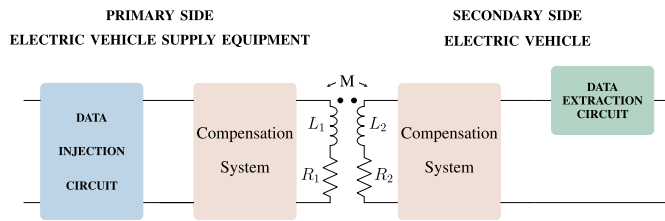

Fig. 18. PS data circuit connection.

can be used to select the data injection/extraction method is the power at which the system will operate. If a transformer is used, its specifications should be checked to guarantee that the maximum power it supports is higher than the power at which the system will operate. If this is not the case, it will cause problems in power transmission, and damage to components may occur. On the other hand, if a toroidal core is used, the possibility of core saturation must be taken into account when power is increased. Core saturation occurs when the magnetic field present is greater than the core can withstand, which, in addition to being affected by the power, will depend on the physical characteristics of the core. If core saturation occurs, changes in the current do not generate changes in the magnetic flux, and core permeability becomes ineffective with a nonideal coil. This limits the maximum magnetic field that can flow through the core. In terms of component price, toroidal cores are usually a more cost-effective option than commercial transformers.

XI. COMPENSATION SYSTEM

According to the fundamentals described in Section II, a possible classification of the compensation systems used in the designs that we reviewed is listed in Table XI. These are the systems related to the power transmission. It should be noted that, in systems such as those proposed in [97], a multiple output can be achieved through an intermediate unit that uses the same compensation system as the primary and secondary circuits, in order to realize a second power transmission. We should also mention that *LCC* compensation can be used as a filter for the inverter's square signal output, as proposed in [125].

One of the handicaps to be dealt with in the wireless charging of EVs is the misalignment between the pair of coupled coils on both sides of the circuit. In a practical situation, it is difficult to get both coils perfectly aligned, while the vehicle is charging. For this reason, one of the crucial criteria when choosing the compensation system is its tolerance to misalignment. The effects of misalignments on power transmission have been widely studied, but it should be noted that the misalignment between coils also directly affects the bandwidth of the data system. As indicated in [126], vertical misalignment affects the communication capacity of the channel more than horizontal misalignment. Nevertheless, the bandwidth alteration is not only related to the direction of misalignment but also to the compensation system used. The authors conclude that a *PP* compensation system offers the highest communication capacity for misalignment on both the horizontal and vertical axes, while *SP* compensation offers the lowest channel capacity. It should be mentioned that the

DR is directly related to the bandwidth through the Nyquist theorem. This theorem establishes that $DR = 2 * B * \log_2(L)$, with *DR* being the DR, i.e., the number of bits per second, *B* the bandwidth of the channel, and *L* the number of signal levels. Therefore, a change in bandwidth directly leads to a change in the *DR*.

The compensation system also has a relevant impact on the correct demodulation of the data when misalignment occurs. The impedance reflected from the secondary side to the primary side depends on the mutual inductance and the specific topology of the compensation system. Changes in this impedance lead to variations in the amplitude and/or phase of the primary current and, consequently, in the voltage induced on the secondary side. The magnitude of these changes for a particular coil misalignment is related to the topology of the compensation system. Thus, for a specific coil displacement, one compensation system may generate a greater amplitude or phase variation than another. For correct data demodulation, these variations may not be understood as data changes (those generated by the data source). We should consider the misalignment conditions of our SWPDT system to decide if the compensation system and the modulation technique are appropriate for them.

When we analyze the data transmission circuit, we find that the type of data compensation system is sometimes different from the type of power compensation system. For example, Qian et al. [98] propose to use *SS* compensation for power transmission; they opt for *SP* compensation for data transmission and reception circuits. The decision to change the compensation system may be motivated by the characteristics of the demodulator circuit that first implements a voltage divider. Since the capacitor is connected in parallel with the data coil, the voltage, thus, remains constant. However, most of the solutions opt to use the same type of compensation for data and power. When we analyze these cases, we find that the prevailing compensation system is *SS* since it is the one most widely proposed. One of the advantages of the *SS* compensation, in addition to its simplicity, is the need for a smaller amount of copper in the windings [124], which can be very useful considering that one of the windings will have to be placed in a mobile element (the EV). Another of the most widely used systems is *LCC*. In this case, the decision to use this configuration is driven by its numerous advantages, such as an output current that is independent of the load, zero voltage switching (*ZVS*), and the filtering of a large part of the harmonics generated in the inverter and rectifier, as indicated in [103] and [104].

To complement the compensation system, it is important to remember that, when we want to optimize the data channel, resonant tanks can be included in a particular branch of the circuit, consisting of a coil (L_{RT}) and a capacitor (C_{RT}) connected in series or in parallel, as shown in Fig. 19. These elements must be in resonance at the frequency of the data signal, and a different behavior is observed depending on the connection of these elements.

- 1) *Series LC Tank*: It behaves as a short circuit at the data frequency and has high impedance at the power frequency (blocking the passage of the power carrier).

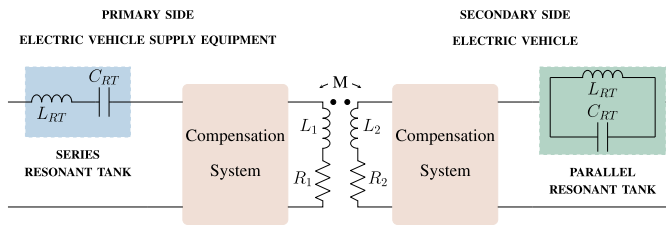

Fig. 19. Parallel and series resonant tanks, generic scheme.

TABLE XI

SUMMARY OF POWER COMPENSATION SYSTEMS USED

Compensation system	Resonant Tank	Ref.
SS	No	[91], [89], [98], [100], [101], [105], [37], [94], [41], [107], [95] [110], [92], [990]
	Yes	[106], [111]
SP	No	[99], [28]
PP	No	[93]
PS	No	[113]
LCC	Yes	[102], [103], [115]
	No	[104], [108], [109], [114], [116]
LCC-Series	No	[96], [97], [112]

2) *Parallel LC Tank*: It behaves as an open circuit at the data frequency and has low impedance at the power frequency (the power carrier can pass through it but not the data carrier).

Taking advantage of this property, a circuit can be designed to block or allow each of these signals to pass through and prevent the interference between them from being too significant, as proposed in [102], [103], and [106]. In some designs such as [104] and [109], different configurations are proposed to avoid these resonant tanks or wave trappers without the data signal significantly affecting the power carrier signal. Yao et al. [104] suggest dividing the main windings into two parts, L_{p1}/L_{p2} and L_{s1}/L_{s2} , injecting and extracting the data through one part of the winding. Wei et al. [109] formulate a design using a multipole mechanism known as DD coil, in which the data are injected through one of the D coils and transferred by the single-coupled coils of the transmitting D coil and the receiving D coil. This system not only avoids using wave trappers but also restricts the magnetic field mainly to the coupling mechanism and has a high tolerance to misalignment in the Y -axis. All these configurations can be seen in Table XI that also shows whether or not the design makes use of resonant tanks in order to optimize data transmission through the power channel.

XII. COMPARATIVE ANALYSIS

To summarize all the SWPDT system configurations reviewed, each of the solutions and their most important characteristics have been grouped in Table XII. Considering that the main classification is the one described in Section VI,

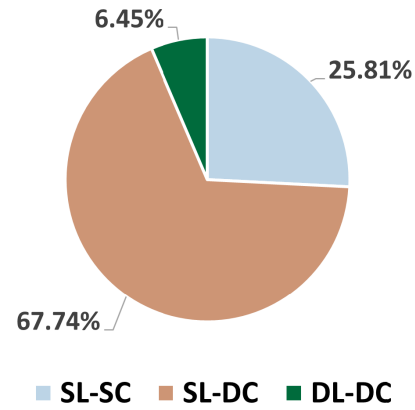

Fig. 20. Percentage of use of each topology.

a summary of the main advantages and disadvantages according to this grouping is also presented in Table XIII.

After reviewing the above configurations, we can conclude that there is no single principle to follow when designing an SWPDT system. However, certain design criteria prevail over others.

After classifying the systems, we can deduce that SL-DC is the most commonly used topology in terms of the number of signals and number of links. This is related to the fact that this topology does not involve phase, frequency, or amplitude variations in the power signal, as is the case with SL-SC, and does not require the inclusion of new coupled coils for data transmission, as is the case with DL-DC topology. The SL-SC configuration offers the advantage of being the simplest configuration and generally requires fewer components, while the DL-DC configuration minimizes interference between the data signal and the power signal as they are transmitted on different channels. However, according to the literature reviewed, these solutions do not attract the same interest as the SL-DC configuration, as can be seen in Fig. 20.

A clear conclusion can be drawn from this first classification. As can be seen in Fig. 21, SL-DC and DL-DC configurations use frequencies in the order of MHz for data transmission, while SL-SC solutions stay in the kHz range. This leads to the conclusion that the choice of data signal frequency tends to use frequencies of an order of magnitude higher and not lower as proposed in [100] and [101].

As mentioned above, in SL-DC systems both the data signal and the power signal coexist in the same channel, so it is only in this topology that resonant tanks are used. The inclusion of resonant tanks is important to avoid the effect of power signal harmonics in data transmission and to prevent the data signal from flowing into the power circuit and interfering with the power electronics.

Regarding the type of communication established in SWPDT systems, there is a clear tendency to use half-duplex communications, where information is transmitted in both directions at different times, as can be observed in Fig. 22. Following the literature review, it has been observed that, for the SL-SC configuration, a full-duplex configuration has not been proposed. The motivation can be that is highly challenging to make at least two different modifications to the

TABLE XII
SUMMARY TABLE OF SOLUTIONS REVIEWED

Ref.	Number of Links and Signals	Power carrier frequency	Data carrier frequency	Data communication type	Signals combination	Modulation	Compensation system	Coil geometry	Data injection/extraction method	Data rate
[66]	SL-SC	85 kHz	5 kHz and 10 kHz	Simplex	-----	FSK	SS	Circular	-----	<i>Not specified</i>
[89]	SL-SC	83 kHz	83 kHz	Half-Duplex	-----	2-QAM	SS	Circular	-----	<i>Not specified</i>
[90]	SL-SC	100 kHz	100 kHz	Simplex	-----	DASK	SS	Circular	-----	<i>Not specified</i>
[91]	SL-SC	100 kHz	100 kHz	Half-Duplex	-----	DPSK	SS	Circular	-----	50 kbps
[92]	SL-SC	100 kHz	100 kHz	Simplex	-----	DDPSK	SS	Circular	-----	100 kbps
[93]	SL-SC	22 kHz	<i>Not specified</i>	Half-Duplex	-----	BFSK	PP	Circular	-----	<i>Not specified</i>
[94]	SL-SC	85 kHz and 87 kHz	85 kHz and 87 kHz forward	Half-Duplex	-----	FSK	SS	Not specified	-----	2 kbps
[95]	SL-SC	85 kHz and 83 kHz	85 kHz and 83 kHz	Half-Duplex	-----	FSK	SS	Circular	-----	1 kbps
[28]	SL-DC	22.4 kHz	1.67 MHz	Half-Duplex	FDM	OOK	SP	Circular	Transformer, series	20 kbps
[37]	SL-DC	85 kHz	2 MHz	Half-Duplex	FDM	OOK	SS	Not specified	Transformer, series	<i>Not specified</i>
[98]	SL-DC	85 kHz	5 MHz and 6.25 MHz	Full-Duplex	FDM	DQPSK	SS	Rectangular	Toroidal-core inductor, series	64 kbps
[99]	SL-DC	22.4 kHz	13.56 MHz and 6.78 MHz	Full-Duplex	FDM and TDM	<i>Not specified</i>	SP	Not specified	Transformer, series	<i>Not specified</i>
[100]	SL-DC	150 kHz	8 kHz	Half-Duplex	FDM	BPSK	SS	Not specified	Transformer, parallel	1 kbps
[101]	SL-DC	100 kHz	8 kHz	Simplex	FDM	BPSK	SS	Not specified	-----	1 kbps
[102]	SL-DC	85 kHz	3 MHz	Simplex	FDM	ASK	LCC	Not specified	Transformer, parallel	40 kbps
[103]	SL-DC	85 kHz	2 MHz and 1.2 MHz	Full-Duplex	FDM	ASK	LCC	Circular	Direct connection and resonant tank, parallel	80 kbps
[104]	SL-DC	85 kHz	5.5 MHz and 4.5 MHz	Full-Duplex	FDM	FSK	LCC	Circular	Transformer, parallel	500 kbps
[105]	SL-DC	80 kHz	10.7 MHz	Half-Duplex	FDM	ASK	SS	Circular	Direct connection, series	80 kbps
[106]	SL-DC	85 kHz	5 MHz	Half-Duplex	FDM	<i>Not specified</i>	SS	Not specified	RLC injector / extractor and Resonant tanks, series and parallel	<i>Not specified</i>
[107]	SL-DC	85 kHz	850 kHz	Half-Duplex	FDM	OOK	SS	Not specified	Transformer, parallel	28.33 kbps
[108]	SL-DC	85 kHz	1.65 MHz and 1.5 MHz	Half-Duplex	FDM	FSK	LCC	Circular	Transformer, series	150 kbps
[109]	SL-DC	85 kHz	1 MHz	Half-Duplex	FDM	OOK	LCC	DD	Transformer, parallel	166.7 kbps
[110]	SL-DC	28 kHz	756 kHz	Half-Duplex	<i>Not specified</i>	ASK and FSK	SS	Circular	Transformer, series	5 kbps forward, 10 kbps backward
[111]	SL-DC	28.3 kHz	1.67 MHz	Simplex	FDM	OOK	SS	Circular	Transformer, series and resonant tanks	<i>Not specified</i>
[112]	SL-DC	50 kHz	2 MHz	Full-Duplex	FDM	ASK	LCC-Series	Circular	Transformer parallel (reverse) and transformer series (forward)	10 kbps forward and 200 kbps backward
[113]	SL-DC	91 kHz	10 MHz	Simplex	<i>Not specified</i>	ASK	PS	Not specified	Modulation Module and RLC extractor	560 kbps
[114]	SL-DC	100 kHz	1.9 MHz and 3.2 MHz	Full-Duplex	FDM	ASK	LCC	Circular	Transformer, parallel	600 kbps
[115]	SL-DC	100 kHz	1.9 MHz and 3.2 MHz	Full-Duplex	FDM	ASK	LCCL	Circular	Transformer, parallel and resonant tanks	200 kbps
[116]	SL-DC	85 kHz	2 MHz and 1.2 MHz	Full-Duplex	FDM	ASK	LCC-CLC	Circular	Transformer, series	250 kbps forward and 170 kbps backward
[96]	DL-DC	200 kHz	6 MHz	Simplex	-----	ASK	LCC-Series	Square	-----	19.2 kbps
[97]	DL-DC	200 kHz	6 MHz	Simplex	-----	ASK	LCC-Series	Square and bipolar	-----	19.2 kbps

TABLE XIII
COMPARATIVE TABLE OF MAIN CLASSIFICATION ACCORDING TO NUMBER OF LINKS AND SIGNALS

Number of signals and links	Advantages	Disadvantages
SL-SC	<ul style="list-style-type: none"> - A single signal is required to transmit power and data. - Lower number of components. - Data transfer and power transfer are equally sensitive to misalignment. - Simpler to implement. 	<ul style="list-style-type: none"> - Constant current, constant voltage and constant power is difficult to achieve. - The charging time increases and the average transmission efficiency degrades.
SL-DC	<ul style="list-style-type: none"> - Constant current, constant voltage and constant power can be achieved. - It is the most flexible and commonly used configuration. - Data transfer and power transfer are equally sensitive to misalignment. - Higher data rate in the implementations reviewed. 	<ul style="list-style-type: none"> - FDM or TDM techniques should be used for simultaneous signal transmission. - Appearance of circulating currents. - Higher number of components than SL-SC. - It is necessary to include extra electronics (coils, transformers) for data transmission. - Ripple generated by semiconductors could result in incorrect data processing.
DL-DC	<ul style="list-style-type: none"> - Constant current, constant voltage and constant power can be achieved. - Data and power signal are transmitted on different channels. - Charging time and power efficiency are not modified by the data. 	<ul style="list-style-type: none"> - It is the most expensive configuration due to the extra data coils needed. - It is the least used configuration. - Cross-coupling between data and power coils. - Higher number of components than for SL-SC and SL-DC. - It is necessary to introduce filters. - Position between coils must be carefully designed to minimize the coupling between the data and power coils. - Data transfer is more sensitive to misalignment than in SL-SC and SL-DC.

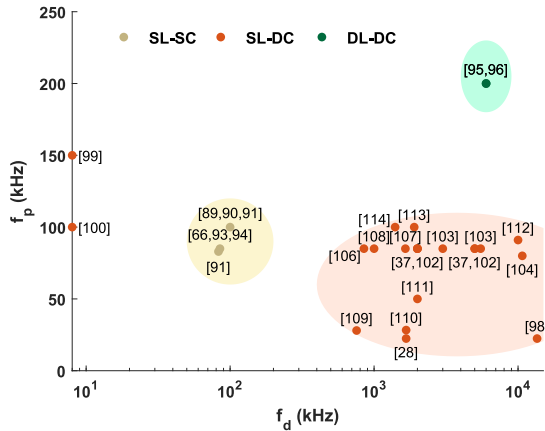

Fig. 21. f_d versus f_p in SL-SC, SL-DC, and DL-DC configurations.

power signal at the same instant of time, as required in SL-SC. All configurations with full-duplex communication have been proposed in SL-DC solutions, as the possibility of using two data signals at different frequencies facilitates their integration in such systems.

On the other hand, in this comparison, it should be mentioned that the most commonly used compensation systems are SS and *LCC*. In SL-SC systems, there is a clear tendency to use SS compensation; however, in the SL-DC topology, *LCC* compensation takes relevance. It is noteworthy that *LCC* compensation provides a significant advantage in SL-DC systems. In these solutions, the transmission of a data signal is achieved through the inclusion of a signal, generally of an order of magnitude higher than the power carrier signal. This

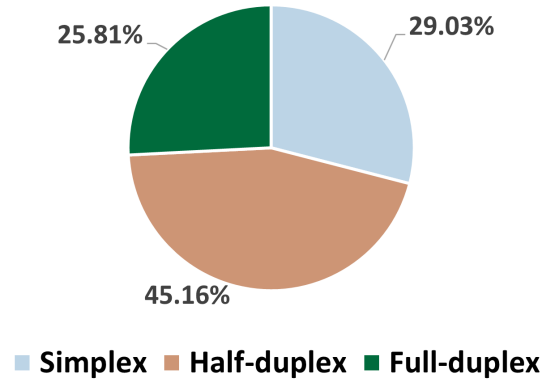

Fig. 22. Percentage of use of each communication technology.

means that special attention must be paid to the harmonics transmitted through the circuit. The *LCC* topology allows a large part of the harmonics arriving at the primary coil, which originates from the inverter's square output signal, to be filtered out.

There are two features that are unique to SL-DC systems: the signal combination technique and the method of data injection and extraction. First, the combination of signals is mostly based on FDM technology, where signals of different frequencies are combined in the same channel. Moreover, it is noteworthy that, in 89% of these systems, the frequency used for data transmission is greater than or equal to 1 MHz, which facilitates the coexistence of this signal with the power signal (which is in the order of kHz). With regard to the injection/extraction method, in most solutions, a transformer is specifically designed to insert or extract the data signal. As for

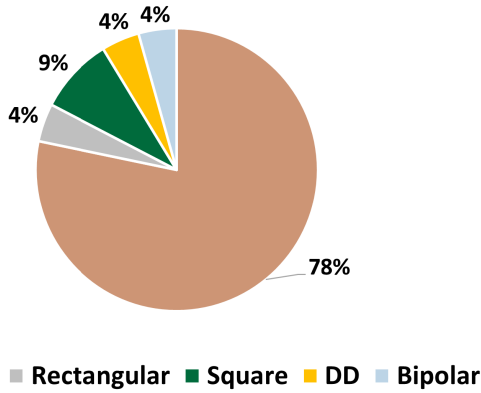

Fig. 23. Percentage of use of each coil geometry.

the connection of these transformers to the power circuit, there is no clear trend, as a similar number of solutions with series and parallel connections have been found.

The modulation techniques used in these SWPDT systems are diverse. According to the main classification, it can be seen that, in SL-SC systems, FSK and its variants are the most commonly used techniques. In SL-DC and DL-DC systems, however, the trend is more toward the use of the ASK/OOK technique due to its simplicity.

The geometry of the coils used in this type of system is in most cases circular although there are some specific cases where rectangular and DD coils are used, as shown in Fig. 23. In this part of the comparison, two main conclusions can be drawn. The first conclusion is that many papers do not consider the design of the coil as a relevant factor, as they do not provide information on its dimensions and geometry. On the other hand, for wireless charging of EVs, the recommendations of the SAE J2954 standard must be followed. This standard establishes the geometry of the coils, with their exact dimensions. It is noteworthy that the solutions reviewed in the literature have not focused their efforts on this highly important parameter.

Finally, it is necessary to mention that the DRs found in the literature range from 1 to 600 kb/s. However, despite this wide difference, it has been found that the systems with the minimum DR (1 kb/s) are those using a data signal with a frequency lower than or equal to the power signal. Attention should be paid to this relation as it may be an indication that these systems cannot be used in specific applications requiring high DRs.

It is very important to deeply analyze the DR during the design process of a wireless charger. Although some communication systems such as *LCC* or *LCL* significantly reduce the DR requirement to the order of Hz for cycle-by-cycle control, control is not the only communication objective in wireless chargers. As mentioned in Section IV and briefly shown in Table III, the use of a communication protocol, such as OCPP or ISO 15118, results in the exchange of a large number of messages during the communication between the EV and the EVSE. Thus, the integration of a communication protocol in wireless chargers forces the system to comply with

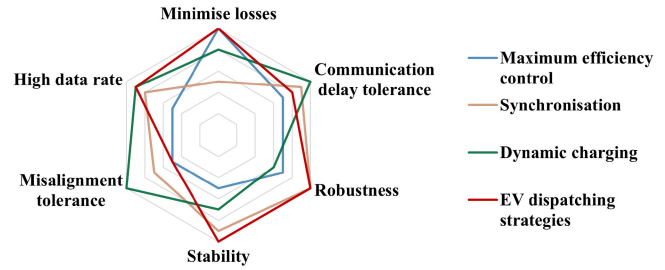

Fig. 24. Case studies critical parameters.

minimum time requirements for the exchange of messages that must be satisfied.

With the previous analysis, we now proceed to give some design guidelines for the use cases described in Section III.

XIII. DISCUSSION OF RELEVANT FEATURES IN CASE STUDIES

We will analyze different criteria presented in the classification of this article according to the needs of each use case described in Section III. Specifically, we will discuss those requirements that are critical for the implementation. In order to highlight the importance of each design criterion for each case study, the graph in Fig. 24 has been elaborated. In this graph, it can be directly observed that each of the applications has certain essential main requirements for the correct operation of these systems. The design parameters that directly affect the fulfillment of these requirements are detailed next.

A. Maximum Efficiency Control

Systems with maximum efficiency control aim to minimize losses in every part of the circuit. Thus, it is important to choose the optimal combination of components and criteria that allows the system to work at its maximum efficiency point. For this use case, we consider that the main objectives for the choice of design criteria are low losses and robustness. According to this criterion, we can consider the following guidelines.

- 1) *Number of Links and Signals*: In this case, it is noteworthy that, in the classification proposed in previous sections, only the SL-SC case carries out a modification of the power signal to perform data transmission. Although the modifications are usually not very significant, they can lead to slight losses in the overall efficiency of the system. Thus, the principle of operation of SL-SC systems may be contrary to the objective of maximum efficiency controls, and their use would not be recommended for this specific scenario. Instead, SL-DC or DL-DC systems can be used, with appropriate analysis of the effect of the data signal on the power signal.
- 2) *Data Communication Type*: For the choice of this criterion, it is necessary to consider that many systems have control in both the primary and secondary circuit converters. This control must have constant communication

in both directions in order to work according to the same variables. Therefore, in this case, we propose the use of full-duplex or half-duplex communication.

- 3) *Data Modulation*: In this case, the data transmitted is of great importance for the correct functioning of these systems since the entire control is carried out on the basis of the value received. It is, therefore, essential that the data received are correct. For this reason, a robust modulation technique must be chosen. Among the simplest techniques, FSK or DPSK modulation would be proposed.
- 4) *Compensation System*: In order to choose the appropriate compensation system, its performance in terms of efficiency will be considered. Among the monoresonant compensation systems, SS has the best performance, while, among the multiresonant systems, *LCC* stands out. However, in terms of efficiency, SS achieves a higher maximum value than *LCC*.

B. Synchronization

In reference to synchronization, there are systems that base their control on the prediction/deduction of variables of the primary circuit, which are used as a reference in the secondary circuit. Therefore, it would be convenient to consider that the objective of these systems is stability. Keeping this idea in mind, we propose the following recommendations.

- 1) *Number of Links and Signals*: It should be noted that the synchronization between the power converters is a process that must be carried out in a short period of time. Therefore, for the choice of this criterion, the DR is prioritized. As shown in Table XII, the configuration offering the highest DR is the SL-DC, which will initially be the most optimal solution.
- 2) *Data Communication Type*: In synchronized control systems, both circuits should ideally have constant information from the system, so the exchange of information between them becomes important. Thus, the use of half-duplex or full-duplex communication is proposed.
- 3) *Signal Multiplexing Technique*: The TDM modulation technique requires synchronization between the transmitter and receiver, which must be carried out prior to data transmission. This makes this technique not recommended for systems requiring synchronization between power converters, as this will delay the start of the communication and, consequently, the start of synchronization. Thus, the use of the FDM technique is more recommended.
- 4) *DR*: An important factor to consider when integrating an SWPDT system in the synchronization of power converters is the DR. It is important to note that the synchronization process must be carried out in the shortest possible time, so a requirement to be taken into account is that the DR is as high as possible. If data are considered to be a set of 8 bits, the time required for its transmission can be deduced in a simple way. Fig. 25 shows the curve defining the relation between the DR (from 1 b/s to 20 kb/s) and the transmission

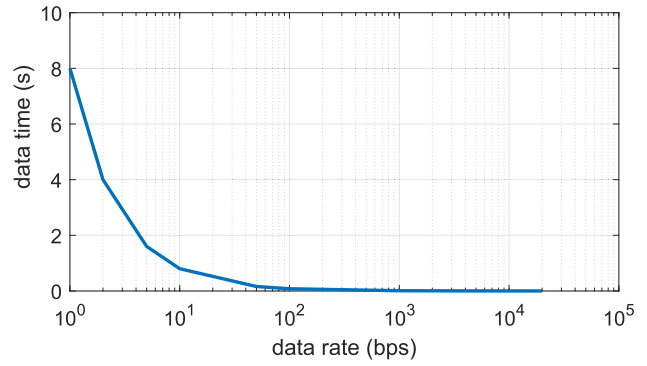

Fig. 25. DR versus transmission time in an 8-bit data.

time (from 8 s to 400 μ s). As indicated in [76], for synchronization, times longer than milliseconds should be avoided; therefore, it is recommended that, for the design of an SWPDT system for this application, the DR should be at least 8 kb/s.

- 5) *Compensation System*: In order to avoid instabilities in the system, it is advisable to use compensation systems with series connections in the primary circuit so that no current peaks occur. In the case of monoresonant technologies, SS compensation stands out. For multiresonant technologies, *LCC* compensation facilitates control in the secondary circuit, reducing the instabilities that can be caused by the rectifier.

C. Dynamic Charging

For the dynamic charging case study, it can be deduced that the clearest design criterion would be that the system could offer a high tolerance to misalignment so all components and configurations should be chosen to pursue that goal. In particular, we have identified the following recommendations.

- 1) *Number of Links and Signals*: As briefly mentioned in the previous paragraph, in dynamic charging systems, a high tolerance to misalignment is required since, during the charging process, it is not possible to ensure that the coils are aligned. Among the topologies presented in this article, we consider that the least suitable is the DL-DC since having a second pair of coils for data transmission can lead to a double problem of coil alignment. On the other hand, we also consider the use of SL-SC technology unsuitable since, during the dynamic charging process, the power signal can suffer fluctuations, which can be confused with the sending of data. We, therefore, propose the use of SL-DC technology.
- 2) *Data Communication Type*: The data transmission in dynamic charging systems must be done in both directions, as this can help in the positioning of the coils, as well as in knowing the state of the vehicle's battery at any given moment. Furthermore, this communication must be done at high speed, as the time that the secondary coil remains over the primary coil is limited. For this reason, the use of full-duplex communication is proposed.

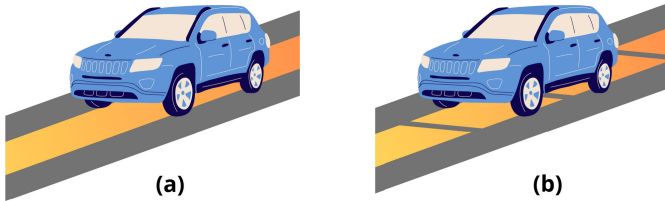

Fig. 26. Dynamic charger pads: (a) single pad and (b) multiple pads.

- 3) *Signal Multiplexing Technique*: Since, in the FDM multiplexing technique, the data can be sent at any time, this configuration will be chosen over TDM. This avoids high latencies, and communication in both directions takes place at the same instant of time, which will speed up the process.
- 4) *Compensation System*: The *LCC* compensation system has good performance in misalignment situations, and it has been widely used in the literature for this purpose [127], [128]. For this reason, this configuration is proposed as the optimal choice.
- 5) *DR*: The most important communication requirement is to achieve low latency since, as mentioned in the previous paragraphs, the design of a dynamic charging system prioritizes the speed of data transmission. Each specific dynamic charging application will have specific requirements defining the maximum latency, DR, and so on. We recommend the definition of simple and robust communication protocols to reduce the data exchange.
- 6) *Coil Design*: In the literature related to dynamic charging systems, a variety of design proposals can be found. However, we consider that not all designs would be appropriate for SWPDT in dynamic charging. Mainly two different solutions can be distinguished, as shown in Fig. 26: one solution using a single long primary coil and another solution using a large number of primary coils, which are switched as the vehicle moves over them. To implement SWPDT systems in dynamic charging, the speed at which the vehicle moves over the primary coil must be considered. This speed can be up to 100 km/h and would, therefore, represent a strong restriction in the communication process. The use of shorter primary coils may result in incomplete data transmission due to the short period of time the vehicle is on a coil. For this reason, the use of a single primary coil benefits the implementation of an SWPDT system.

D. EV Dispatching Strategies

Finally, with regard to EV dispatching strategies, it should be mentioned that the most critical requirements are the minimization of power transmission losses and the system's stability and robustness.

- 1) *Number of Links and Signals*: In EV dispatching strategies, it is important to minimize the power losses as the charging scheduling is conducted in order to achieve optimal energy management. Considering the types of configurations according to this criterion, we consider

that the use of SL-DC or DL-DC technology would be an optimal choice since, in these topologies, it is not necessary to modify the power signal to establish communication.

- 2) *Data Communication Type*: In this application, it is necessary to establish communication from EV charging station to EV and vice versa. Thus, there is a need to implement a bidirectional communication. Simplex communication is not recommended for this application, being half-duplex and full-duplex as the most appropriate options.
- 3) *Signal Multiplexing Technique*: In these systems, it is important that communication delays are minimized to avoid latencies that difficult real-time charging scheduling. In the case of implementing an SL-DC system, the use of FDM is recommended, as it does not require the division of the data into time slots.
- 4) *Compensation System*: As mentioned in case *Synchronization* stability is one of the most critical parameters of this application. Following the previous statement, the use of compensation systems with series compensation in the primary is recommended. The trend shows that the most commonly used systems are SS and *LCC* due to their good performance to avoid instabilities.
- 5) *DR*: The DR is important since, in this application, energy management is carried out in real time, analyzing at certain points in time variables that are involved in the charging process, such as the price of energy, energy demand, or the current charging status of the battery. This leads to the need to establish communication with high DRs and robust communication protocols that ensure the correct transmission of data through the system.

XIV. FUTURE RESEARCH TRENDS AND CHALLENGES

To conclude this review paper, this section outlines the topics that we consider most relevant for future developments of SWPDT technology in EVs. In Fig. 27, a resume diagram is represented. We have highlighted in blue the future trends and in red the challenges involved in integrating these systems into wireless charging.

After reviewing all the articles included in this article, it is clear that there are still areas in which further research is needed for SWPDT in EVs.

- 1) *Integration of Data and Power Coils*: In DL-DC systems, the study of the integration of data coils into the power transmission circuit needs special attention. In these systems, the positioning of the data coil is of great importance, as interference can occur, which can disturb the data transmission in the circuit. Not only the location of the data coils but also the positioning of the power coils in relation to other elements of the circuit must be studied. Compensation systems could be integrated with the main coils in a compact structure so that a unified system is achieved. In this way, SWPDT systems could be presented as two modules, one primary and one secondary, in which all elements are seamlessly integrated. An interesting field of work would

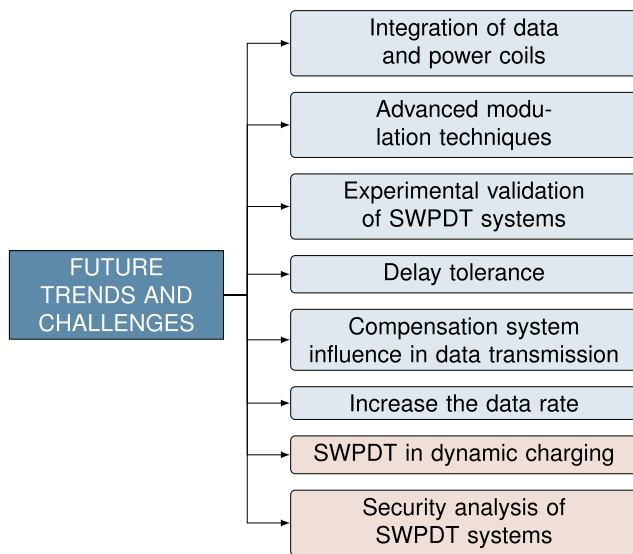

Fig. 27. Diagram of future trends and challenges in SWPDT technology.

be the development of theoretical and experimental studies relating the geometry of the coils used for data transmission to their tolerance to misalignment, with a focus on SWPDT systems. With this analysis, it would be possible to know how misalignment affects data transmission (bandwidth modification, bitrate alteration, and so on), depending on the coil topology used. A study of these characteristics can be beneficial for the optimal design of the data channel of an SWPDT system.

- 2) *Advanced Modulation Techniques for Data Transfer:* Currently, simple modulation techniques, such as ASK, PSK, or FSK, are used. More advanced modulation techniques, such as MSK [129], GMSK [130], or CPFSK [131], could be tested and studied for SWPDT systems to determine whether they offer advantages over the previous ones. In addition, it would be of great interest to carry out studies on the behavior of each of these modulation techniques in situations of misalignment between coils, which are quite common in EVs. Variations in the bandwidth or signal processing errors should be analyzed.
- 3) *Experimental Validations of SWPDT Systems:* It is vital to perform further experimental tests that provide information on the behavior of the system in different situations. For example, the system should be tested to establish whether it complies with the emissions recommended by the standard, either independently or with test platforms connected to the infrastructure, which allow the infrastructure to be studied continuously. Similarly, experimental tests could determine the benefits of using the OCPP protocol in SWPDT systems, as this protocol has mainly been used in solutions with power transmission only. Considering that this review is focused on the use of SWPDT systems for EVs, it is important to carry out experimental tests with SAE J-2954 compliant devices. This is relevant, especially with regard to the design, dimensions, and positioning

of the main coils, which must comply with the requirements of the standard. Furthermore, the behavior of the system can be tested in situations that are far from ideal: for example, where there is electromagnetic interference (EMI) with other devices, both in the radio spectrum close to 85 kHz for the power signal and in the order of MHz for the data signal, which can alter the signals that are transmitted and received. This can prevent the system from operating correctly and generate potentially serious errors. Finally, we would like to highlight the importance of implementing the use cases mentioned in this article in order to expand the literature related to this topic and motivate researchers to continue along these lines of research.

- 4) *Delay Tolerance:* Communication delay is a common feature of all data transmission systems, and it is, therefore, necessary to study its value and variability. The communication delay can be a critical parameter in some applications (referred to as delay-sensitive applications). In the context of EV wireless charging, there are cases where the communication delay tolerance is very restrictive, such as in synchronization or dynamic charging. In synchronization, the delay can imply that the system losses increase during the time when the power converters are not working properly (for instance, when it is not adopting the correct control setpoints to maximize efficiency). In dynamic charging, a delay in data transmission may result in loss of information (e.g., vehicle identification or battery status). The no reception of these data may prevent a correct power transfer, which could lead to inoperative dynamic wireless charging. Furthermore, the protocol for the data involved in dynamic wireless charging could be supported by a connection-oriented protocol. Under this configuration, it is essential to validate that the communication delay and jitter fulfill the requirements for the data exchange established by the protocol.
- 5) *Compensation System Influence in Data Transmission:* Similarly, as demonstrated in Section X, the compensation system is one of the key elements in the design of an SWPDT system. However, after an exhaustive review of the related literature, we only found a few articles that make comparative studies of the behavior of compensation systems in data transmission terms. In these studies, the analysis of the transfer functions would be very relevant, both for the communication channel used for data transmission and for the power transmission channel. Through them, it would be possible to determine the frequency range with the optimum behavior of the whole system, the gain in terms of voltage, and the possible phase variations suffered by the data signal after its transmission through the circuit. This type of analysis also makes it possible to determine whether the system bandwidth or bit rate is suitable for system communication. In addition, the misalignment between the coils also has a direct effect on the data transmission channel, and as discussed in this article, the compensation system is closely linked

to the performance of the system in misalignment situations.

- 6) *Increase the DR*: As can be seen from Table XII, DRs barely reach 600 kb/s. These values are still far below what is achievable with commercial technologies, such as Bluetooth or Wi-Fi. The low DR will limit its control performance in wireless EV charging applications. Therefore, we consider that a theoretical study is needed to find out the DR limit of different types of SWPDT systems and to identify the ways to implement optimized SWPDT-based communication. For this reason, we consider it interesting that new research should focus, in addition to the above, on increasing the DR in this type of system, so that it does not involve a significant problem in comparison with other technologies. The defined technologies to increase the bit rate must also offer a high tolerance to misalignment, as it is a strong requirement in future EV applications.

Finally, we would like to highlight that, in addition to these future studies, there are challenges not yet addressed by the scientific literature. Specifically, we highlight the following.

- 1) *SWPDT in Dynamic Charging*: As we suggest in Section III, one of the most attractive points in the field of EVs is dynamic charging, whereby the vehicle's battery is recharged, while the vehicle is in motion. However, no research paper has been found, which focuses on the simultaneous transmission of power and data in dynamic chargers. For dynamic charging SWPDT chargers, it would be necessary to study parameters such as the minimum DR for communication, the optimal system type for the charging in motion (SL-SC, SL-DC, or DL-DC), and the study of the optimal design criteria of the data channel. It should also be noted that misalignment affects wireless transmission, so it would be necessary to adapt the system to the conditions at any given time, in order to achieve optimal transmission.
- 2) *Security Analysis of SWPDT Systems*: As mentioned throughout this article, the transmission of data through power coils is a more robust method to potential attacks in terms of cybersecurity. However, we consider the need for an in-depth analysis to determine the level of security of SWPDT systems. In this analysis, we propose to carry out experimental tests on wireless charging platforms in which conclusions can be drawn to define the behavior of the system. For example, it would be very useful to perform various intentional cyberattacks, studying the ease of access to the system, the level of robustness of the communication, the threats of altering the data, the possibility of varying parameters that could lead to major failures, and so on. In particular, we find it interesting to analyze the cybersecurity issues that may arise in the case studies and their consequences.

REFERENCES

- [1] A. Triviño, J. M. González-González, and J. A. Aguado, "Wireless power transfer technologies applied to electric vehicles: A review," *Energies*, vol. 14, no. 6, p. 1547, Mar. 2021.
- [2] J. Byun, W.-J. Son, J. H. Lee, S. Ann, and B. K. Lee, "Current sensorless ZPA frequency tracking control of IPT system with LCCL-S topology," in *Proc. 10th Int. Conf. Power Electron. ECCE Asia*, 2019, pp. 1–6.
- [3] R. Ruffo, V. Cirimele, M. Diana, M. Khalilian, A. L. Ganga, and P. Guglielmi, "Sensorless control of the charging process of a dynamic inductive power transfer system with an interleaved nine-phase boost converter," *IEEE Trans. Ind. Electron.*, vol. 65, no. 10, pp. 7630–7639, Oct. 2018.
- [4] P.-A. Gori, D. Sadarnac, A. Caillierez, and S. Loudot, "Sensorless inductive power transfer system for electric vehicles: Strategy and control for automatic dynamic operation," in *Proc. 19th Eur. Conf. Power Electron. Appl.*, Sep. 2017, pp. P.1–P.10.
- [5] A. Triviño-Cabrera, J. M. González-González, and J. A. Aguado, *Wireless Power Transfer for Electric Vehicles: Foundations and Design Approach*. Cham, Switzerland: Springer, 2020.
- [6] C.-C. Huang, C.-L. Lin, and Y.-K. Wu, "Simultaneous wireless power/data transfer for electric vehicle charging," *IEEE Trans. Ind. Electron.*, vol. 64, no. 1, pp. 682–690, Jan. 2017.
- [7] *OCPP 2.0.1, Protocols, Home—Open Charge Alliance*. Accessed: Jun. 14, 2021. [Online]. Available: <https://www.openchargealliance.org/protocols/ocpp-201/>
- [8] M. Khalilian and P. Guglielmi, "Primary-side control of a wireless power transfer system with double-sided LCC compensation topology for electric vehicle battery charging," in *Proc. IEEE Int. Telecommun. Energy Conf. (INTELEC)*, Oct. 2018, pp. 1–6.
- [9] H. T. Mouftah and M. Erol-Kantarci, "Smart grid communications: Opportunities and challenges," in *Handbook of Green Information and Communication Systems*. Amsterdam, The Netherlands: Elsevier, 2013, pp. 631–663.
- [10] L. E. Frenzel, "Networking: Wired and wireless," in *Electronics Explained*. Amsterdam, The Netherlands: Elsevier, 2018.
- [11] P. Bulić, G. Kojek, and A. Biasizzo, "Data transmission efficiency in Bluetooth low energy versions," *Sensors*, vol. 19, no. 17, p. 3746, Aug. 2019.
- [12] *Different Wi-Fi Protocols and Data Rates*. Accessed: Jun. 14, 2021. [Online]. Available: <https://www.intel.com/content/www/us/en/support/articles/000005725/wireless/legacy-intel-wireless-products.html>
- [13] M. Uddin and T. Nadeem, "RF-Beep: A light ranging scheme for smart devices," in *Proc. IEEE Int. Conf. Pervasive Comput. Commun. (PerCom)*, Mar. 2013, pp. 114–122.
- [14] R. Rondón, M. Gidlund, and K. Landernäs, "Evaluating Bluetooth low energy suitability for time-critical industrial IoT applications," *Int. J. Wireless Inf. Netw.*, vol. 24, no. 3, pp. 278–290, Sep. 2017.
- [15] A. Pedross and K. Witrals, "Analysis of nonideal multipliers for multichannel autocorrelation UWB receivers," in *Proc. IEEE Int. Conf. Ultra-Wideband*, Sep. 2012, pp. 140–144.
- [16] H. Chen, Z. Cheng, Z. Qian, J. Wu, and X. He, "Application of SWPDT in the feedback control of wireless EV charging," in *Proc. IEEE Energy Convers. Congr. Expo.*, Oct. 2020, pp. 1012–1015.
- [17] X. Li, C. Tang, X. Dai, P. Deng, and Y. Su, "An inductive and capacitive combined parallel transmission of power and data for wireless power transfer systems," *IEEE Trans. Power Electron.*, vol. 33, no. 6, pp. 4980–4991, Jun. 2018.
- [18] J. A. Alvarez-Cedillo, P. Perez-Romero, and M. Hernandez-Bolaños, "Bluetooth intrusion techniques," *Int. J. Comput. Sci. Inf. Technol. Secur.*, vol. 2, no. 1, pp. 208–215, 2012.
- [19] P. Patel, A. Merchant, N. Tailor, and C. Trivedi, "Bluetooth security issues," *Int. J. Comput. Sci. Eng. Technol.*, vol. 6, pp. 1–15, Jan. 2015.
- [20] R. Bali, "Bluejacking technology: Overview, key challenges and initial research," *Int. J. Eng. Trends Technol.*, vol. 4, no. 7, pp. 1–11, 2013.
- [21] A. Lonsetta, P. Cope, J. Campbell, B. Mohd, and T. Hayajneh, "Security vulnerabilities in Bluetooth technology as used in IoT," *J. Sensor Actuator Netw.*, vol. 7, no. 3, p. 28, Jul. 2018.
- [22] P. R. Suri and S. Rani, "Bluetooth security—need to increase the efficiency in pairing," in *Proc. IEEE SoutheastCon*, Apr. 2008, pp. 607–609.
- [23] S. Zeadally, F. Siddiqui, and Z. Baig, "25 years of Bluetooth technology," *Future Internet*, vol. 11, no. 9, p. 194, Sep. 2019.
- [24] *Securing Wireless Networks*. CISA, Rosslyn, VA, USA, 2021.
- [25] S. Khanji, F. Iqbal, and P. Hung, "ZigBee security vulnerabilities: Exploration and evaluating," in *Proc. 10th Int. Conf. Inf. Commun. Syst. (ICICS)*, Jun. 2019, pp. 52–57.

- [26] P. Radmand et al., "ZigBee/ZigBee PRO security assessment based on compromised cryptographic keys," in *Proc. Int. Conf. P2P, Parallel, Grid, Cloud Internet Comput.*, Nov. 2010, pp. 465–470.
- [27] N. Vidgren, K. Haataja, J. L. Patiño-Andres, J. J. Ramírez-Sanchis, and P. Toivanen, "Security threats in ZigBee-enabled systems: Vulnerability evaluation, practical experiments, countermeasures, and lessons learned," in *Proc. 46th Hawaii Int. Conf. Syst. Sci.*, Jan. 2013, pp. 5132–5138.
- [28] J. Wu, C. Zhao, Z. Lin, J. Du, Y. Hu, and X. He, "Wireless power and data transfer via a common inductive link using frequency division multiplexing," *IEEE Trans. Ind. Electron.*, vol. 62, no. 12, pp. 7810–7820, Dec. 2015.
- [29] I. Krikidis, S. Timotheou, S. Nikolaou, G. Zheng, D. W. K. Ng, and R. Schober, "Simultaneous wireless information and power transfer in modern communication systems," *IEEE Commun. Mag.*, vol. 52, no. 11, pp. 104–110, Nov. 2014.
- [30] D. Niculae, M. Iordache, M. Stanculescu, M. L. Bobaru, and S. Deleanu, "A review of electric vehicles charging technologies stationary and dynamic," in *Proc. 11th Int. Symp. Adv. Topics Electr. Eng. (ATEE)*, Mar. 2019, pp. 1–4.
- [31] N. Khan, H. Matsumoto, and O. Trescases, "Wireless electric vehicle charger with electromagnetic coil-based position correction using impedance and resonant frequency detection," *IEEE Trans. Power Electron.*, vol. 35, no. 8, pp. 7873–7883, Aug. 2020.
- [32] J. J. Joseph, J. L. Juliha, and F. T. Josh, "Review on the recent development of the power converters for electric vehicle," in *Proc. 2nd Int. Conf. Commun. Electron. Syst. (ICCES)*, Oct. 2017, pp. 641–644.
- [33] T. D. P. Perera, D. N. K. Jayakody, S. K. Sharma, S. Chatzinotas, and J. Li, "Simultaneous wireless information and power transfer (SWIPT): Recent advances and future challenges," *IEEE Commun. Surveys Tuts.*, vol. 20, no. 1, pp. 264–302, 1st Quart., 2018.
- [34] J. Huang, C.-C. Xing, and C. Wang, "Simultaneous wireless information and power transfer: Technologies, applications, and research challenges," *IEEE Commun. Mag.*, vol. 55, no. 11, pp. 26–32, Nov. 2017.
- [35] L. Han and L. Li, "Integrated wireless communications and wireless power transfer: An overview," *Phys. Commun.*, vol. 25, pp. 555–563, Dec. 2017.
- [36] Y. Yao, P. Sun, X. Liu, Y. Wang, and D. Xu, "Simultaneous wireless power and data transfer: A comprehensive review," *IEEE Trans. Power Electron.*, vol. 37, no. 3, pp. 3650–3667, Mar. 2022.
- [37] F. Corti, A. Reatti, M. C. Piccirilli, F. Grasso, L. Paolucci, and M. K. Kazimierzczuk, "Simultaneous wireless power and data transfer: Overview and application to electric vehicles," in *Proc. IEEE Int. Symp. Circuits Syst. (ISCAS)*, Oct. 2020, pp. 1–5.
- [38] M. J. Karimi, A. Schmid, and C. Dehollain, "Wireless power and data transmission for implanted devices via inductive links: A systematic review," *IEEE Sensors J.*, vol. 21, no. 6, pp. 7145–7161, Mar. 2021.
- [39] A. Javan-Khoshkholgh and A. Farajidavar, "Simultaneous wireless power and data transfer: Methods to design robust medical implants for gastrointestinal tract," *IEEE J. Electromagn., RF Microw. Med. Biol.*, vol. 6, no. 1, pp. 3–15, Mar. 2022.
- [40] Y. Zhang, S. Chen, X. Li, Z. She, F. Zhang, and Y. Tang, "Coil comparison and downscaling principles of inductive wireless power transfer systems," in *Proc. IEEE PELS Workshop Emerg. Technol., Wireless Power Transf. (WoW)*, Nov. 2020, pp. 116–122.
- [41] Y. Li et al., "A new coil structure and its optimization design with constant output voltage and constant output current for electric vehicle dynamic wireless charging," *IEEE Trans. Ind. Informat.*, vol. 15, no. 9, pp. 5244–5256, Sep. 2019.
- [42] M. Mohammad, J. L. Pries, O. C. Onar, V. P. Galigekere, G.-J. Su, and J. Wilkins, "Comparison of magnetic field emission from unipolar and bipolar coil-based wireless charging systems," in *Proc. IEEE Transp. Electrification Conf. Expo (ITEC)*, Jun. 2020, pp. 1201–1207.
- [43] D. Patil, M. K. McDonough, J. M. Miller, B. Fahimi, and P. T. Balsara, "Wireless power transfer for vehicular applications: Overview and challenges," *IEEE Trans. Transport. Electrification*, vol. 4, no. 1, pp. 3–37, Mar. 2018.
- [44] K. Fotopoulou and B. W. Flynn, "Wireless power transfer in loosely coupled links: Coil misalignment model," *IEEE Trans. Magn.*, vol. 47, no. 2, pp. 416–430, Feb. 2011.
- [45] V. Cirimele, F. Freschi, and P. Guglielmi, "Wireless power transfer structure design for electric vehicle in charge while driving," in *Proc. Int. Conf. Electr. Mach. (ICEM)*, Sep. 2014, pp. 2461–2467.
- [46] V. Shevchenko, O. Husev, R. Strzelecki, B. Pakhaliuk, N. Poliakov, and N. Strzelecka, "Compensation topologies in IPT systems: Standards, requirements, classification, analysis, comparison and application," *IEEE Access*, vol. 7, pp. 120559–120580, 2019.
- [47] *Wireless Power Transfer for Light-Duty Plug-in/Electric Vehicles and Alignment Methodology*, Standard SAE J2954B, 2019.
- [48] J. Shin et al., "Contactless power transfer systems for on-line electric vehicle (OLEV)," in *Proc. IEEE Int. Electric Vehicle Conf.*, Mar. 2012, pp. 1–4.
- [49] M. Pickelsimer, L. Tolbert, B. Ozpineci, and J. M. Miller, "Simulation of a wireless power transfer system for electric vehicles with power factor correction," in *Proc. IEEE Int. Electr. Vehicle Conf.*, Mar. 2012, pp. 1–6.
- [50] H. Moon, S. Ahn, and Y. Chun, "Design of a novel resonant reactive shield for wireless charging system in electric vehicle," in *Proc. IEEE Wireless Power Transf. Conf.*, May 2014, pp. 220–223.
- [51] H. Li, J. Li, K. Wang, W. Chen, and X. Yang, "A maximum efficiency point tracking control scheme for wireless power transfer systems using magnetic resonant coupling," *IEEE Trans. Power Electron.*, vol. 30, no. 7, pp. 3998–4008, Jul. 2015.
- [52] L. Ji, Y. Song, L. Wang, and C. Liao, "A novel control strategy for wireless charging in electric vehicle based on class E amplifier," in *Proc. IEEE PELS Workshop Emerg. Technol., Wireless Power Transf. (WoW)*, May 2017, pp. 1–4.
- [53] H. L. Li, A. P. Hu, G. A. Covic, and C. Tang, "A new primary power regulation method for contactless power transfer," in *Proc. IEEE Int. Conf. Ind. Technol.*, Feb. 2009, pp. 1–12.
- [54] B. Pang, J. Deng, P. Liu, and Z. Wang, "Secondary-side power control method for double-side LCC compensation topology in wireless EV charger application," in *Proc. 43rd Annu. Conf. IEEE Ind. Electron. Soc.*, Oct. 2017, pp. 7860–7865.
- [55] C. Cui, K. Song, C. Zhu, Q. Zhang, Y. Liu, and S. Dong, "State feedback controller design of dynamic wireless power transfer system," in *Proc. IEEE PELS Workshop Emerg. Technol., Wireless Power Transf. (Wow)*, Jun. 2018, pp. 1–5.
- [56] Z.-H. Wang, Y.-P. Li, Y. Sun, C.-S. Tang, and X. Lv, "Load detection model of voltage-fed inductive power transfer system," *IEEE Trans. Power Electron.*, vol. 28, no. 11, pp. 5233–5243, Nov. 2013.
- [57] K. Colak, E. Asa, M. Bojarski, D. Czarkowski, and O. C. Onar, "A novel phase-shift control of semibridgeless active rectifier for wireless power transfer," *IEEE Trans. Power Electron.*, vol. 30, no. 11, pp. 6288–6297, Nov. 2015.
- [58] H. H. Wu, A. Gilchrist, K. D. Sealy, and D. Bronson, "A high efficiency 5 kW inductive charger for EVs using dual side control," *IEEE Trans. Ind. Informat.*, vol. 8, no. 3, pp. 585–595, Aug. 2012.
- [59] Q. Zhao, A. Wang, J. Liu, and X. Wang, "The load estimation and power tracking integrated control strategy for dual-sides controlled LCC compensated wireless charging system," *IEEE Access*, vol. 7, pp. 75749–75761, 2019.
- [60] Y. Lu and D. Ma, "Wireless power transfer system architectures for portable or implantable applications," *Energies*, vol. 9, no. 12, p. 1087, Dec. 2016.
- [61] K. Hata, T. Imura, and Y. Hori, "Efficiency maximization of wireless power transfer based on simultaneous estimation of primary voltage and mutual inductance using secondary-side information," in *Proc. 42nd Annu. Conf. IEEE Ind. Electron. Soc.*, Oct. 2016, pp. 4493–4498.
- [62] G. Sanborn and A. Phipps, "Standards and methods of power control for variable power bidirectional wireless power transfer," in *Proc. IEEE Wireless Power Transf. Conf. (WPTC)*, May 2017, pp. 1–4.
- [63] Y.-C. Hsieh, Z.-R. Lin, M.-C. Chen, H.-C. Hsieh, Y.-C. Liu, and H.-J. Chiu, "High-efficiency wireless power transfer system for electric vehicle applications," *IEEE Trans. Circuits Syst. II, Exp. Briefs*, vol. 64, no. 8, pp. 942–946, Aug. 2017.
- [64] B. X. Nguyen et al., "An efficiency optimization scheme for bidirectional inductive power transfer systems," *IEEE Trans. Power Electron.*, vol. 30, no. 11, pp. 6310–6319, Nov. 2015.
- [65] S. Mukherjee et al., "Control of output power in primary side LCC and secondary series tuned wireless power transfer system without secondary side sensors," in *Proc. IEEE Energy Convers. Congr. Expo.*, May 2020, pp. 1–12.
- [66] X. Liu, X. Yang, D. Ma, N. Jin, X. Lai, and H. Tang, "A novel simultaneous wireless information and power transfer system," in *Proc. IEEE Wireless Power Transf. Conf. (WPTC)*, Jun. 2019, pp. 212–215.

- [67] A. Krivchenkov and D. Sedykh, "Analysis of packets delay in wireless data networks," *Transp. Telecommun. J.*, vol. 16, no. 4, pp. 330–340, Dec. 2015.
- [68] M. J. Morón, R. Luque, E. Casilari, and A. Díaz-Estrella, "An analytical model for estimating the delay in Bluetooth communications with serial port profile," in *Proc. Int. Conf. Wireless Commun. Mobile Comput., Connecting World Wirelessly*, New York, NY, USA, 2009, pp. 1178–1183.
- [69] Y. Yao, L. Rao, X. Liu, and X. Zhou, "Delay analysis and study of IEEE 802.11p based DSRC safety communication in a highway environment," in *Proc. IEEE INFOCOM*, Apr. 2013, pp. 1591–1599.
- [70] J. M. González-González, A. Triviño-Cabrera, and J. A. Aguado, "Model predictive control to maximize the efficiency in EV wireless chargers," *IEEE Trans. Ind. Electron.*, vol. 69, no. 2, pp. 1244–1253, Feb. 2022.
- [71] A. Zakerian, S. Vaez-Zadeh, and A. Babaki, "A dynamic WPT system with high efficiency and high power factor for electric vehicles," *IEEE Trans. Power Electron.*, vol. 35, no. 7, pp. 6732–6740, Jul. 2020.
- [72] F. Liu, K. Li, K. Chen, and Z. Zhao, "A phase synchronization technique based on perturbation and observation for bidirectional wireless power transfer system," *IEEE J. Emerg. Sel. Topics Power Electron.*, vol. 8, no. 2, pp. 1287–1297, Jun. 2020.
- [73] S. Jia, C. Chen, P. Liu, and S. Duan, "A digital phase synchronization method for bidirectional inductive power transfer," *IEEE Trans. Ind. Electron.*, vol. 67, no. 8, pp. 6450–6460, Aug. 2020.
- [74] V.-B. Vu et al., "Operation of inductive charging systems under misalignment conditions: A review for electric vehicles," *IEEE Trans. Transport. Electrification*, vol. 9, no. 1, pp. 1857–1887, Mar. 2023.
- [75] A. Triviño, J. M. Gonzalez-Gonzalez, and M. Castilla, "Review on control techniques for EV bidirectional wireless chargers," *Electronics*, vol. 10, no. 16, p. 1905, Aug. 2021.
- [76] D. Zhang, M. Chen, B. Li, X. Wang, X. Sun, and F. Jiang, "Synchronization strategy based on resonant current detection for bidirectional wireless charging system," *IEEE Trans. Power Electron.*, vol. 37, no. 9, pp. 11436–11449, Sep. 2022.
- [77] A. N. Azad, A. Echols, V. A. Kulyukin, R. Zane, and Z. Pantic, "Analysis, optimization, and demonstration of a vehicular detection system intended for dynamic wireless charging applications," *IEEE Trans. Transport. Electrification*, vol. 5, no. 1, pp. 147–161, Mar. 2019.
- [78] Z. Li, J. Li, S. Li, Y. Yu, and J. Yi, "Design and optimization of asymmetric and reverse series coil structure for obtaining quasi-constant mutual inductance in dynamic wireless charging system for electric vehicles," *IEEE Trans. Veh. Technol.*, vol. 71, no. 3, pp. 2560–2572, Mar. 2022.
- [79] R. Tavakoli, T. Shabaniyan, E. M. Dede, C. Chou, and Z. Pantic, "EV misalignment estimation in DWPT systems utilizing the roadside charging pads," *IEEE Trans. Transport. Electrification*, vol. 8, no. 1, pp. 752–766, Mar. 2022.
- [80] K. Shi, C. Tang, Z. Wang, X. Li, Y. Zhou, and Y. Fei, "A magnetic integrated method suppressing power fluctuation for EV dynamic wireless charging system," *IEEE Trans. Power Electron.*, vol. 37, no. 6, pp. 7493–7503, Jun. 2022.
- [81] A. A. S. Mohamed, A. A. Shaier, H. Metwally, and S. I. Selem, "An overview of dynamic inductive charging for electric vehicles," *Energies*, vol. 15, no. 15, p. 5613, Aug. 2022.
- [82] E. Gryparis, P. Papadopoulos, H. C. Leligou, and C. S. Psomopoulos, "Electricity demand and carbon emission in power generation under high penetration of electric vehicles. A European union perspective," *Energy Rep.*, vol. 6, pp. 475–486, Nov. 2020.
- [83] *Open Charge Point Protocol 1.0*, Open Charge Alliance, Arnhem, The Netherlands, 2015.
- [84] *Open Charge Point Protocol 1.6*, Open Charge Alliance, Arnhem, The Netherlands, 2015.
- [85] *Open Charge Point Protocol 2.0.1*, Open Charge Alliance, Arnhem, The Netherlands, 2018.
- [86] D. Wellisch, J. Lenz, A. Faschingbauer, R. Pöschl, and S. Kunze, "Vehicle-to-grid AC charging station: An approach for smart charging development," *IFAC-PapersOnLine*, vol. 48, no. 4, pp. 55–60, 2015.
- [87] *Road Vehicles—Vehicle-to-Grid Communication Interface—Part 2: Network and Application Protocol Requirements*, Standard ISO 15118-2:2016, 2016.
- [88] V.-B. Vu, D.-H. Tran, and W. Choi, "Implementation of the constant current and constant voltage charge of inductive power transfer systems with the double-sided LCC compensation topology for electric vehicle battery charge applications," *IEEE Trans. Power Electron.*, vol. 33, no. 9, pp. 7398–7410, Sep. 2018.
- [89] J.-J. Kao, C.-L. Lin, Y.-C. Liu, C.-C. Huang, and H.-S. Jian, "Adaptive bidirectional inductive power and data transmission system," *IEEE Trans. Power Electron.*, vol. 36, no. 7, pp. 7550–7563, Jul. 2021.
- [90] P. Guo, R. Yuan, C. Cai, H. Lin, and L. Yang, "High-data-frequency-ratio information transmission method for fast dynamic response SWPIT systems based on DASK modulation," *IEEE J. Emerg. Sel. Topics Power Electron.*, vol. 9, no. 3, pp. 3822–3834, Jun. 2021.
- [91] R. Yuan, P. Guo, C. Cai, and L. Yang, "Quasi-independent bidirectional communication methods for simultaneous wireless power and information transmission," *Appl. Sci.*, vol. 10, no. 20, p. 7130, Oct. 2020.
- [92] P. Guo, R. Yuan, Y. Chen, C. Cai, and L. Yang, "High-bandwidth-utilization wireless power and information transmission based on DDPSK modulation," *IEEE Access*, vol. 7, pp. 85560–85572, 2019.
- [93] C.-C. Huang and C.-L. Lin, "Wireless power and bidirectional data transfer scheme for battery charger," *IEEE Trans. Power Electron.*, vol. 33, no. 6, pp. 4679–4689, Jun. 2018.
- [94] J. Wu, C. Zhao, S. He, N. Jin, and Z. Dou, "Simulation of information bidirectional transmission using single switch receiver in a SWIPT system," in *Proc. IEEE 4th Inf. Technol. Mechatronics Eng. Conf. (ITOEC)*, Dec. 2018, pp. 879–883.
- [95] J. Wu, C. Zhao, N. Jin, S. He, and D. Ma, "Bidirectional information transmission in SWIPT system with single controlled chopper receiver," *Electronics*, vol. 8, no. 9, p. 1027, Sep. 2019.
- [96] X. Li, J. Hu, Y. Li, H. Wang, M. Liu, and P. Deng, "A decoupled power and data-parallel transmission method with four-quadrant misalignment tolerance for wireless power transfer systems," *IEEE Trans. Power Electron.*, vol. 34, no. 12, pp. 11531–11535, Dec. 2019.
- [97] Y. Li, X. Li, and X. Dai, "A simultaneous wireless power and data transmission method for multi-output WPT systems: Analysis, design, and experimental verification," *IEEE Access*, vol. 8, pp. 206353–206359, 2020.
- [98] Z. Qian, R. Yan, J. Wu, and X. He, "Full-duplex high-speed simultaneous communication technology for wireless EV charging," *IEEE Trans. Power Electron.*, vol. 34, no. 10, pp. 9369–9373, Oct. 2019.
- [99] S. Afshar, S. M. R. Tousei, and H. Karami, "Wireless power and full-duplex data transfer system using the combination of TDM and FDM through a same inductive link," in *Proc. Iranian Conf. Electr. Eng. (ICEE)*, May 2018, pp. 1246–1250.
- [100] M. Trautmann, B. Sanftl, R. Weigel, and A. Koelpin, "Frequency separation stage design for a reliable data link in an IPT system for electric vehicles," in *Proc. IEEE 2nd Annu. Southern Power Electron. Conf. (SPEC)*, Dec. 2016, pp. 1–5.
- [101] B. Sanftl, C. Joffe, M. Trautmann, R. Weigel, and A. Koelpin, "Reliable data link for power transfer control in an inductive charging system for electric vehicles," in *IEEE MTT-S Int. Microw. Symp. Dig.*, May 2016, pp. 1–3.
- [102] P. Y. Wang, L. Sang, and K. Wang, "Optimization of simultaneous wireless power and data transmission system with single coil," in *Proc. 8th Int. Conf. Power Electron. Syst. Appl. (PESA)*, Dec. 2020, pp. 1–6.
- [103] Y. Fan, Y. Sun, X. Dai, Z. Zuo, and A. You, "Simultaneous wireless power transfer and full-duplex communication with a single coupling interface," *IEEE Trans. Power Electron.*, vol. 36, no. 6, pp. 6313–6322, Jun. 2021.
- [104] Y. Yao, H. Cheng, Y. Wang, J. Mai, K. Lu, and D. Xu, "An FDM-based simultaneous wireless power and data transfer system functioning with high-rate full-duplex communication," *IEEE Trans. Ind. Informat.*, vol. 16, no. 10, pp. 6370–6381, Oct. 2020.
- [105] H. Zheng, Z. Wang, Y. Li, and P. Deng, "Data transmission through energy coil of wireless power transfer system," in *Proc. IEEE PELS Workshop Emerg. Technol., Wireless Power Transf. (WoW)*, May 2017, pp. 1–4.
- [106] Z. Qian, R. Yan, J. Wu, and X. He, "Construction and analysis of communication channels for simultaneous wireless power and data transmission," in *Proc. 44th Annu. Conf. IEEE Ind. Electron. Soc.*, Oct. 2018, pp. 4793–4798.
- [107] Y. Wang, Y. Yao, Y. Guan, X. Liu, M. Liu, and D. Xu, "A novel modulation and demodulation method for wireless power and data transmission," in *Proc. IEEE Transp. Electrification Conf. Expo, Asia-Pacific*, Aug. 2017, pp. 1–6.
- [108] Y. Yao et al., "Analysis and design of a simultaneous wireless power and data transfer system featuring high data rate and signal-to-noise ratio," *IEEE Trans. Ind. Electron.*, vol. 68, no. 11, pp. 10761–10771, Nov. 2021.

- [109] G. Wei, J. Feng, J. Zhang, C. Wang, C. Zhu, and S. Yurievich Ostanin, "An efficient power and data synchronous transfer method for wireless power transfer system using double-D coupling coil," *IEEE Trans. Ind. Electron.*, vol. 68, no. 11, pp. 10643–10653, Nov. 2021.
- [110] Y. Sun et al., "Bidirectional simultaneous wireless information and power transfer via sharing inductive link and single switch in the secondary side," *IEEE Access*, vol. 8, pp. 184187–184198, 2020.
- [111] J. Wu et al., "A simultaneous wireless information and power transfer system with independent channel for information transfer," *IEEE Access*, vol. 8, pp. 125610–125619, 2020.
- [112] T. Zhang, D. Zhang, and W. Huang, "Research on inductively coupled full duplex communication method with power transmission," in *Proc. Int. Conf. Sens., Meas. Data Anal. Era Artif. Intell. (ICSMD)*, Oct. 2020, pp. 229–234.
- [113] X. Li, H. Wang, and X. Dai, "A power and data decoupled transmission method for wireless power transfer systems via a shared inductive link," *Energies*, vol. 11, no. 8, p. 2161, Aug. 2018.
- [114] P.-Y. Wang, Y. Sun, Y. Feng, T. Feng, Y. Fan, and X. Li, "An improvement of SNR for simultaneously wireless power and data transfer system with full-duplex communication mode," *IEEE Trans. Power Electron.*, vol. 37, no. 2, pp. 2413–2424, Feb. 2022.
- [115] P. Wang, Y. Sun, T. Feng, Y. Fan, and Y. Feng, "Simultaneous wireless power and data transfer system with full-duplex mode based on double-side LCCL and dual-notch filter," *IEEE J. Emerg. Sel. Topics Power Electron.*, vol. 10, no. 3, pp. 3140–3151, Jun. 2022.
- [116] Y. Jing, W. Feng, K. Qiao, L. Yang, S. Wang, and L. Lu, "Simultaneous wireless power and data transfer system with full-duplex mode based on LCC/CLC resonant network," *IEEE Trans. Power Electron.*, vol. 38, no. 4, pp. 5549–5560, Apr. 2023.
- [117] Á. Jaramillo-Duque, N. Muñoz-Galeano, J. Ortiz-Castrillón, J. López-Lezama, and R. Albarracín-Sánchez, "Power loss minimization for transformers connected in parallel with taps based on power chargeability balance," *Energies*, vol. 11, no. 2, p. 439, Feb. 2018.
- [118] J. Price and T. Goble, "Signals and noise," in *Telecommunications Engineer's Reference Book*. Butterworth-Heinemann, 1993, pp. 1–10.
- [119] C. M. White, "Multiplexing," in *Encyclopedia of Information Systems*. Amsterdam, The Netherlands: Elsevier, 2003, pp. 213–224.
- [120] S. Faruque, "Time division multiplexing (TDM)," in *Radio Frequency Source Coding Made Easy* (SpringerBriefs in Electrical and Computer Engineering). Cham, Switzerland: Springer, 2015, pp. 91–118.
- [121] S. Faruque, "Amplitude shift keying (ASK)," in *Radio Frequency Source Coding Made Easy* (SpringerBriefs in Electrical and Computer Engineering). Cham, Switzerland: Springer, 2017, pp. 45–55.
- [122] R. W. Middlestead, "Phase shift keying (PSK) modulation, demodulation, and performance," in *Digital Communications With Emphasis on Data Modems*. Hoboken, NJ, USA: Wiley, 2017.
- [123] R. W. Middlestead, "Frequency shift keying (FSK) modulation, demodulation and performance," in *Digital Communications With Emphasis on Data Modems*. Hoboken, NJ, USA: Wiley, 2017.
- [124] J. Sallan, J. L. Villa, A. Llombart, and J. F. Sanz, "Optimal design of ICPT systems applied to electric vehicle battery charge," *IEEE Trans. Ind. Electron.*, vol. 56, no. 6, pp. 2140–2149, Jun. 2009.
- [125] J. Hu and J. Zhao, "Design of wireless power transfer system with input filter," *IET Power Electron.*, vol. 13, no. 7, pp. 1–12, 2020.
- [126] A. Triviño-Cabrera, Z. Lin, and J. Aguado, "Impact of coil misalignment in data transmission over the inductive link of an EV wireless charger," *Energies*, vol. 11, no. 3, p. 538, Mar. 2018.
- [127] Q. Zhu, L. Wang, Y. Guo, C. Liao, and F. Li, "Applying LCC compensation network to dynamic wireless EV charging system," *IEEE Trans. Ind. Electron.*, vol. 63, no. 10, pp. 6557–6567, Oct. 2016.
- [128] E. ElGhanam, M. Hassan, and A. Osman, "Design of a high power, LCC-compensated, dynamic, wireless electric vehicle charging system with improved misalignment tolerance," *Energies*, vol. 14, no. 4, p. 885, Feb. 2021.
- [129] A. Grami, "Passband digital transmission," in *Introduction to Digital Communications*. Amsterdam, The Netherlands: Elsevier, 2016.
- [130] R. Ziemer, "Modulation," in *Encyclopedia of Physical Science and Technology*. Amsterdam, The Netherlands: Elsevier, 2002.
- [131] L.-K. Chen, "Timing misalignment monitoring," in *Timing Misalignment Monitoring*. Amsterdam, The Netherlands: Elsevier, 2010.



Inmaculada Casaucao Tenllado was born in Córdoba, Spain. She received the B.S. degree in electronics engineering and the master's degree in electronic systems for intelligent environments from the University of Málaga, Málaga, Spain, in 2019 and 2020, respectively, where she is currently pursuing the Ph.D. degree in the Mechatronics Engineering Programme with a focus on the simultaneous transmission of power and data in wireless chargers for electric vehicles.

She has also worked on research projects related to microgrid design and control techniques for wireless bidirectional chargers.



Alicia Triviño Cabrera received the master's degree in telecommunication engineering and the master's degree in computer science engineering from the University of Málaga, Málaga, Spain, in 2002 and 2008, respectively. Her thesis, which she defended in 2007, focused on wireless networks.

She is currently an Associate Professor with the University of Málaga. In the field of electric vehicle wireless chargers, she has played an active role in designing and developing several prototypes, including features such as bidirectionality and dynamic charging. Her research interests include wireless power transfer.

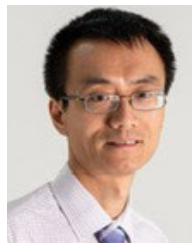

Zhengyu Lin (Senior Member, IEEE) received the B.Sc. and M.Sc. degrees from the College of Electrical Engineering, Zhejiang University, Hangzhou, China, in 1998 and 2001, respectively, and the Ph.D. degree from Heriot-Watt University, Edinburgh, U.K., in 2005.

He is currently a Reader with the School of Mechanical, Electrical and Manufacturing Engineering, Loughborough University, Loughborough, U.K. His research interests include power electronics and its applications in renewable energy, energy storage, wireless power transfer, motor drives, microgrids, and multienergy systems.