

# Radar-Communications Convergence: Coexistence, Cooperation, and Co-Design

Alex R. Chiriyath, *Student Member, IEEE*, Bryan Paul, *Student Member, IEEE*,  
and Daniel W. Bliss, *Fellow, IEEE*

**Abstract**—In this paper, we introduce a radar information metric, the estimation rate, that allows the radar user to be considered in a multiple-access channel enabling performance bounds for joint radar-communications coexistence to be derived. Traditionally, the two systems were isolated in one or multiple dimensions. We categorize new attempts at spectrum-space-time convergence as either coexistence, cooperation, or co-design. The meaning and interpretation of the estimation rate and what it means to alter it are discussed. Additionally, we introduce and elaborate on the concept of “not all bits are equal,” which states that communications rate bits and estimation rate bits do not have equal value. Finally, results for joint radar-communications information bounds and their accompanying weighted spectral efficiency measures are presented.

**Index Terms**—Joint radar-communications, SSPARC, radar information theory, performance bounds.

## I. INTRODUCTION

**R**ADAR and communications have typically been developed in isolation. A growing interest of electromagnetic radio frequency (RF) convergence is driving the future growth and operation of both class of systems [1]. Recently, with growing spectral congestion concerns, researchers have begun investigating methods of spectrum-space-time harmony. We define radar communications RF convergence to be the operating point at which a given bandwidth allocation is used jointly for radar and communications to mutual benefit.

Achieving RF convergence for joint radar-communications coexistence is incredibly complicated. Even for a simple case involving a single radar and communications link, one must consider spatial, spectral, and temporal degrees of freedom. In practice, there are many contributing sources in a given spectrum-space-time, and regulatory restrictions may not adequately protect both users even if isolation is acceptable. An example of the type of complicated scenario that is associated with achieving RF convergence is shown in Figure 1.

Manuscript received April 8, 2016; September 29, 2016 and January 25, 2017; accepted January 30, 2017. Date of publication February 14, 2017; date of current version April 7, 2017. This work was sponsored in part by DARPA under the SSPARC program. The associate editor coordinating the review of this paper and approving it for publication was C. Clancy.

A. R. Chiriyath and D. W. Bliss are with the Bliss Laboratory of Information, Signals, and Systems and the Center for Wireless Information Systems and Computational Architectures, Arizona State University, Tempe, AZ 85281 USA (e-mail: achiriyath@asu.edu).

B. Paul is with the Bliss Laboratory of Information, Signals, and Systems and the Center for Wireless Information Systems and Computational Architectures, Arizona State University, Tempe, AZ 85281 USA, and also with the General Dynamics Mission Systems, Scottsdale, AZ 85257 USA.

Digital Object Identifier 10.1109/TCCN.2017.2666266

In this work, we delineate solutions to spectral convergence using three categories: coexistence, cooperation, and co-design. We define coexistence methods as those that burden radar and communications transceivers to treat one another as interferers. For these methods, any information required to mitigate the other system’s interference is not shared, and must be estimated.

Cooperative techniques are techniques where some knowledge is shared between systems in order to more effectively mitigate interference relative to one another. In this regime, the systems may not significantly alter their core operation, but willingly exchange information necessary to mutually mitigate interference.

Co-design we define as the paradigm shift of considering communications and radar jointly when designing new systems to maximize their joint performance. Co-designed systems are jointly designed from the ground up, and now have the opportunity to improve their performance over isolated operation. For example, communications users can use codes that are invariant or even beneficial to communications operation, but also benefit radar-like operation for known training sequences. Simultaneously, radar processing can improve channel estimation to assist in equalization for communications systems. Future users will find it advantageous to consider co-designing systems to handle complicated RF convergence scenarios such as the one shown in Figure 1.

### A. Contributions

We present the joint radar-communications problem as a joint *information* problem. Information is chosen because it forces one to identify uncertainty in the situation and develop plans to reduce it. Estimation theory and signal processing are often presented with traditional metrics such as the Cramér-Rao lower bound (CRLB), minimum mean-squared error (MMSE), or signal-to-noise ratio (SNR). However, none of these address information gained from spectral access. When focusing on reducing estimation variance, if the information gained through estimation is minimal, precious spectrum in a given space-time is being inefficiently utilized.

The radar information measure to be used in this work is denoted estimation rate, which was first defined in [2] and extensively discussed in [3] and [4]. These works defined the quantity mathematically, and then presented a series of cooperative joint radar-communications inner bounds on performance. The result is a multiple-access information map,

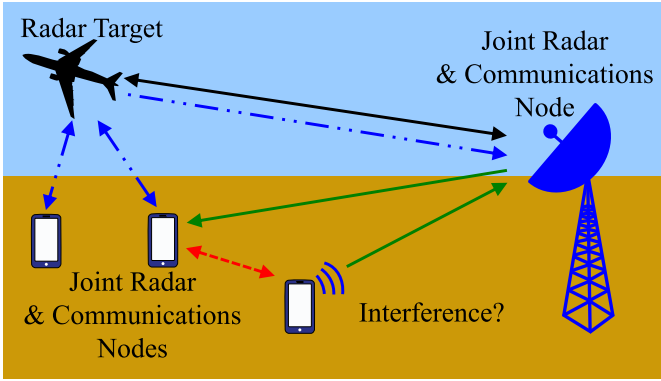

Fig. 1. An example highlighting the difficulties of achieving RF convergence. Future systems must be co-designed to not just mitigate interference, but jointly consider each other in their inherent operation.

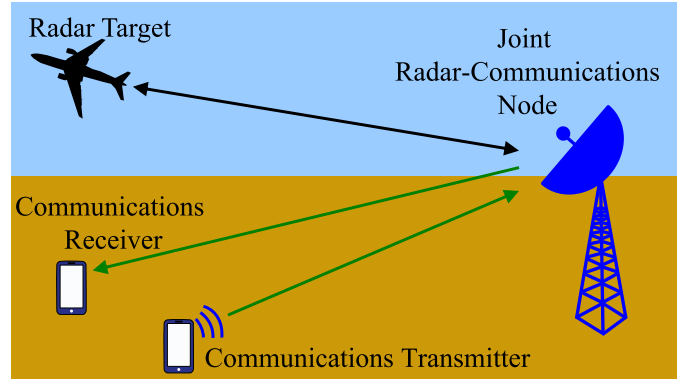

Fig. 2. The joint radar-communications system ‘basic multiple-access scenario.’ This is a simplified version of the complicated RF convergence scenario shown previously. However, it provides a point of departure for discussing future work, and enables tractable, intuitive solutions presented here.

providing systems engineers a region of achievable joint operation within a given spectrum-space-time.

To provide a tractable solution to achieving RF convergence, we define what we call the ‘basic multiple-access scenario.’ It is a simple scenario involving a radar and communications user attempting to use the same spectrum-space-time. This scenario is instructional, and can easily be scaled to more complicated scenarios by using it as a building block to construct real world examples. We present a diagram of the ‘basic multiple-access scenario’ in Figure 2. In this scenario, the joint radar-communications system consists of an active, mono-static, pulsed radar and a single user communications system. We consider the joint radar-communications receiver to be a radar transmitter/receiver that can act as a communications receiver. The joint receiver can simultaneously estimate the radar target parameters from the radar return and decode a received communications signal. While the node architecture can easily be generalized to function as a communications relay by including a communications transmitter, this is not explicitly discussed in this paper. We refer to the scenario described in Figure 2 throughout the rest of this paper.

Despite the difficulty in achieving RF convergence in scenarios such as the one seen in Figure 1, we do know that some important assumptions have to be made in order to develop a tractable solution. Those key assumptions made in this work are as follows

- Radar and communications operate in the same frequency allocation simultaneously
- Joint radar-communications receiver is capable of simultaneously decoding a communications signal and estimating a target parameter
- Radar detection and track acquisition have already taken place.

On top of the assumptions made above, the key assumptions made that apply for the scenario described in Figure 2 are as follows

- Radar system is an active, single-input single-output (SISO), mono-static, and pulsed system
- Radar system operates without any maximum unambiguous range
- A single SISO communications transmitter is present

- Only one radar target is present
- Target range or delay is the only parameter of interest
- Target cross-section is well estimated
- Communications signal is received through an antenna sidelobe; Antenna gains are not identical.

In this paper, we provide a clearer understanding of the estimation rate metric and also look at the optimality (in terms of spectral efficiency) of various joint radar-communications performance bounds. The main goals of this paper are three-fold

- Provide an intuitive understanding of radar estimation rate and the implications of altering it
- Introduce and elaborate on the concept of ‘Not All Bits are Equal’
- Use weighted spectral efficiency to highlight the optimality of joint radar-communications performance bounds.

## B. Background

Along with the estimation rate, the joint radar-communications performance bounds discussed in this paper were first defined in [2]. The estimation rate was extended in [3] to include Doppler measurement and continuous signaling radars. In [4], the metric was defined in more detail, along with additional inner bounds on joint-radar communications performance. Various extensions to the joint radar-communications inner bounds were presented in [5]–[9]. New inner bounds were developed in [10] for waveforms that were jointly optimized for simultaneous radar and communications operation. In [11], we use the I-MMSE [12] to develop bounds on the radar estimation rate (radar mutual information) from MMSE estimation bounds. These bounds are useful when closed form solutions to the estimation rate do not exist. Reference [13] provides an in depth survey of work done in various fields that are relevant to joint sensing and communications with a emphasis on joint radar-communications.

Achieving radar-communications RF convergence is complicated, and so the solution space tends to be greatly varied. Nevertheless, certain methods are gaining more traction than others.

Waveform design has become a dominant research thread in joint radar-communications phenomenology. Researchers have considered a variety of waveform options including orthogonal frequency-division multiplexing (OFDM) [14]–[21]. Most of these results are attempting co-designed systems, where OFDM waveforms are used for bi-static communications, and as a mono-static radar. However, results showed conflicting cyclic prefix requirements, data-dependent ambiguities, and trouble mitigating peak-to-average power ratio (PAPR) for typical radar power requirements. Similar to OFDM, spread spectrum waveforms have been proposed for their attractive, noise-like autocorrelation properties [22]–[24]. MIMO radar techniques have also been proposed, given that the independent transmitted waveforms allow more degrees of freedom for joint radar-communications co-design [25]–[27].

Other researchers looked at spatial mitigation as a means to improve spectral interoperability [28]–[30]. These methods can be considered either coexistence or cooperative, depending on the amount of information shared between users. However, this is merely a form of spatial isolation managed by radiation patterns. Another method of isolation utilized polarization for co-designed systems [31]. Space-time dynamic isolation techniques have been proposed, such as communications devices communicating carefully to avoid spectrum-space-time collisions with rotating radars [32], [33]. These also varied from coexisting to cooperative systems. An overview of interference mitigation techniques that aid in isolation between WiMax networks and ground-based radar systems is provided in [34].

Employing the existing cellular framework has also been proposed as a solution to augment the dwindling radar spectrum [35], [36]. These approaches range from radar systems subscribing as cellular users when there is a need for radar illumination, to using cellular protocols to prioritize radar tasks. As such, the radar is conforming to the design of the cellular user, and is subsequently closer to cooperation than co-design.

Advancements in cognitive radios and radar have been proposed as a natural solution to spectrum congestion problems [37]–[41]. Cognitive radio has been advancing spectral sharing potential in the communications realm [42]. However, RF convergence between radar and communications users is largely an open area of research. These two systems, unlike the cognitive radio user base, have vastly different goals, metrics, and operators. Joint coding techniques, such as robust codes for communications that have desirable radar ambiguity properties, as well as codes that trade data rate and channel estimation error have been investigated as co-design solutions [43]–[46]. Research has been done investigating the effects of passive and parasitic radar systems that passively exploit communications illuminations [47]–[50]. For example, some systems employ multiple orthogonal radar waveforms with embedded communications symbols and exploit the differential phase between waveforms to extract the parasitic data transmission [47], [48].

Information is well known in communications phenomenology, but less so in radar. Perhaps surprisingly, radars were looked at in the context of information theory soon after Shannon’s seminal work [51] by Woodward [52]. Interest resurged many years later with Bell’s work on waveform

design using information for statistical scattering targets [53]. Recent results have found connections between information theory and estimation theory, equating estimation information and the integrated MMSE [12]. The work presented in [54] develops an expression for radar capacity (for radar systems performing target detection only) which, in combination with the traditional communications capacity, can be used to measure the total capacity of a joint radar-communications network. In addition, cognitive radar architectures have been proposed using information to prioritize physical location access based on uncertainty [55]. These advances make the joint consideration of radar and communications information interesting when considering co-designed solutions.

## II. COMMUNICATIONS RATE

In this section, we present a brief exposition of communications capacity theory to lay groundwork for the sections to come. The goal is to understand the basic communications phenomenology and to understand dealing with systems in an information theory context. This section serves as a useful bridge to discuss radar information theory in the next section, and forms the basis of how we consider the joint system.

The communications rate capacity is formally defined as the supremum of achievable communications rates for a given channel model with respect to the input distribution. It tells us how much information as a function of time we can communicate with arbitrarily low bit error rate. This problem was solved by Shannon in his seminal work [51].

### A. Communications Rate Capacity for a Single Link

For our basic multiple-access scenario, we have a single communications user. Here, we present Shannon’s results for the capacity of this link, assuming the user is operating with no interference. We assume we have a single wireless communications link in a continuous memoryless real Gaussian channel with an average power constraint  $P_{\text{com}}$  and fixed bandwidth  $B$  and subject to receiver thermal noise. The capacity of such a channel was shown by Shannon to be [51]

$$\begin{aligned} R_{\text{com}} &\leq \frac{1}{2T_s} \log_2 \left( 1 + \frac{\|b\|^2 P_{\text{com}}}{k_B T_{\text{temp}} B} \right) \\ &= \frac{1}{2T_s} \log_2(1 + \text{SNR}), \end{aligned} \quad (1)$$

where  $T_s = \frac{1}{2B}$  is the independent sampling rate of the band-limited system,  $b$  is the combined gain and communications propagation loss product,  $k_B$  is the Boltzmann constant, and  $T_{\text{temp}}$  is the absolute temperature.

### B. Altering the Communications Rate

As we have stated previously, the communications rate is simply a measure of the amount of arbitrary information that can be transmitted through the channel given spectrum-space-time access. We can increase the communications rate in a fixed bandwidth by:

1) *Changing Source Entropy*: The source entropy is dictated by the source distribution  $p(X)$ . The more we increase

this entropy, the larger the mutual information [56]. While this may appear beneficial, in doing so, we may exceed the average power constraint, violating the maximizing terms of the capacity problem. Ignoring the mutual information construct, we can attempt to communicate at a faster rate (rate taking into account redundant and non-redundant information [56]). However, exceeding the capacity means an arbitrarily low bit error rate (BER) is not achievable. As a result, the spectral efficiency in b/s/Hz goes down when considering a channel with an arbitrarily low BER.

However, if the capacity is not exceeded, we achieve the maximum spectral efficiency given the problem parameters. Thus information must be carefully considered as to the root meaning when trading this parameter, as we see in Section III when considering radar estimation rate.

2) *Changing SNR*: From Equation (1), we see that by increasing the SNR, we get a net gain in information. Sphere packing is a good analogy. In an average power-constrained channel with fixed bandwidth, this amounts to decreasing the noise power. As a result, more “levels” can be transmitted and resolved on average at the receiver, meaning more entropy states and overall more information. Thus by increasing SNR, we can increase the source entropy level at which an arbitrary BER is possible. If less throughput is needed, the bandwidth can be reduced (noting the non-linear mapping), or the communications system can be duty cycled in time. This equates to spectrum-time isolation.

As we see, changing the rate of communication cannot be done arbitrarily, as bit error rates may preclude proper system operation. Increasing the communications rate through SNR is acceptable, but requires reduction of the thermal noise floor, or a change in the channel constraints. As we see in the next section, increasing the complementary radar estimation rate must also be done with careful consideration to proper system operation and estimation performance.

### III. RADAR ESTIMATION RATE

In this section, we present a novel parametrization of radar performance, the estimation rate. The estimation rate is a metric analogous to the communications rate and provides a measure of the information about a target that is gained from radar illumination in radar tracking estimation scenarios. In general, the target has some entropy or information about itself that is not explicitly being communicated to the radar system by the target. Radar illumination can be viewed as the target unwillingly communicating this target entropy or information to the radar receiver. Thus, the radar channel can be characterized as an uncooperative communications channel [4].

We assume that the radar system has some knowledge of the target parameter of interest, based on prior observations, up to some fluctuation. This fluctuation, also called process noise, is modeled by a Gaussian random variable  $n_{\text{parameter,proc}}$  with variance given by  $\langle \|n_{\text{parameter,proc}}\|^2 \rangle = \sigma_{\text{parameter,proc}}^2$ . Throughout the rest of the paper, we only consider radar range estimation. In such a case, the process noise for range fluctuation is interpreted as a fluctuation in delay,  $n_{\tau,\text{proc}}$  with

variance given by  $\langle \|n_{\tau,\text{proc}}\|^2 \rangle = \sigma_{\tau,\text{proc}}^2$ . The radar estimation rate can be extended to include estimation of different target parameters as seen in [3], in which the estimation rate is extended to take into account Doppler estimation.

The estimation rate is formally defined as the quantity that represents the minimum number of bits needed to encode the Kalman residual, which is the statistical deviation from the radar prediction of a target parameter, for a given channel degradation [4]. The estimation rate tells us how much information we stand to gain once we subtract the prediction of the target’s parameter, since the predicted target parameter is already known and does not truly convey any information.

#### A. Estimation Rate for a Single Target

Considering the radar channel to act as an uncooperative communications channel, the process noise,  $n_{\tau,\text{proc}}$ , is the information  $X$  being transmitted. This transmitted information  $X$  is to be degraded by the addition of some noise  $N$ , which for target parameter estimation is given by the radar estimation error,  $n_{\tau,\text{est}}$ , and a noisy measurement of  $X$  is received at the radar receiver system. The estimation rate for our uncooperative channel is therefore given by [56]

$$R_{\text{est}} = \frac{I(X; X + N)}{T_{\text{pri}}}, \quad (2)$$

where  $T_{\text{pri}} = T_{\text{pulse}}/\delta$  is the pulse repetition interval of the radar system,  $T_{\text{pulse}}$  is the radar pulse duration, and  $\delta$  is the radar duty factor.

Assuming that the radar estimation error,  $n_{\tau,\text{est}}$ , is Gaussian with variance  $\langle \|n_{\tau,\text{est}}\|^2 \rangle = \sigma_{\tau,\text{est}}^2$ , the mutual information can be shown to be [56]

$$R_{\text{est}} \leq \frac{1}{2T_{\text{pri}}} \log_2 \left( 1 + \frac{\sigma_{\tau,\text{proc}}^2}{\sigma_{\tau,\text{est}}^2} \right). \quad (3)$$

It should be noted that a Gaussian distribution is used to model the radar estimation error,  $n_{\tau,\text{est}}$ , and process noise,  $n_{\tau,\text{proc}}$ , because Gaussian distributions have a closed form solution to entropy, enabling a closed form solution for the estimation rate to exist. In radar estimation problems where a Gaussian distribution is not appropriate and a closed form solution for the estimation rate does not exist, bounds on the radar estimation rate (radar mutual information) exist which can still capture a measure of radar information [11]. We leave the estimation rate as an inequality because typically systems must perform certain non-ideal processing steps, such as quantization. As a result, the data-processing inequality is enforced [56].

Looking at the ratio of variances  $\frac{\sigma_{\tau,\text{proc}}^2}{\sigma_{\tau,\text{est}}^2}$ , we see that  $\sigma_{\tau,\text{proc}}^2 = \langle \|n_{\tau,\text{proc}}\|^2 \rangle$  is the power of the transmitted information,  $\langle \|X\|^2 \rangle$ , and that  $\sigma_{\tau,\text{est}}^2 = \langle \|n_{\tau,\text{est}}\|^2 \rangle$  is the noise power,  $\langle \|N\|^2 \rangle$ . Thus, the ratio of variances  $\frac{\sigma_{\tau,\text{proc}}^2}{\sigma_{\tau,\text{est}}^2}$  represents the SNR of the uncooperative communications channel that is used to characterize the radar channel. This is more evident when comparing Equation (3) to Equation (1). Thus, Equation (3) can be written as [2]

$$R_{\text{est}} \leq \frac{1}{2T_{\text{pri}}} \log_2(1 + \text{SNR}). \quad (4)$$

If we assume that the radar estimator achieves the CRLB, the variance of delay estimation,  $\sigma_{\tau, \text{est}}^2$ , is given by the CRLB for time delay estimation and Equation (3) can be written as

$$\begin{aligned} R_{\text{est}} &\leq \frac{1}{2T_{\text{pri}}} \log_2 \left( 1 + \left( 8\pi^2 \sigma_{\tau, \text{proc}}^2 B_{\text{rms}}^2 \text{ISNR} \right) \right), \\ &= \frac{1}{2T_{\text{pri}}} \log_2 \left( 1 + \left( 8\pi^2 \sigma_{\tau, \text{proc}}^2 \gamma^2 B^2 \text{ISNR} \right) \right), \end{aligned} \quad (5)$$

where  $B_{\text{rms}}$  is the full RMS bandwidth of the system, ISNR is the integrated SNR given by  $\text{ISNR} = \frac{T_{\text{pulse}} B P_{\text{rad, received}}}{k_B T_{\text{temp}} B}$  where  $P_{\text{rad, received}}$  is the received radar signal power, and  $\gamma$  is the scaling constant between  $B$  and  $B_{\text{rms}}$  that is dependent upon the shape of the radar waveform's power spectral density.  $\gamma$  is related to  $B_{\text{rms}}$  and bandwidth  $B$  as follows

$$\gamma^2 B^2 = (2\pi)^2 B_{\text{rms}}^2. \quad (6)$$

For a flat spectral shape,  $\gamma^2 = (2\pi)^2/12$ .

It should be noted here that if the delay estimator does not achieve the CRLB, the estimation rate is lowered.

### B. Altering the Estimation Rate

As we have stated before, the estimation rate is simply a measure of the amount of information about the target that can be gained through the radar channel through illumination. Thus, an increase in the estimation rate implies an increased amount of information about the target is gained by the radar system through the channel. As we see, increasing the estimation rate can lead to better target parameter estimation performance whereas reducing the estimation rate can result in reduced spectral access. From Equation (3), we see that the estimation rate can be altered by:

1) *Changing Process Noise*: Process noise represents the amount of information of the target that is unknown. From Equation (3), we see that by increasing the process noise, we increase the estimation rate. Increasing the process noise essentially means that the target behaves in an unexpected manner when compared to how the target was modeled by the radar system. Thus, the amount of information that can be gained about the target through radar illumination increases and this is reflected via an increase in the estimation rate.

However, if the target was modeled accurately, then the information content gained through radar illumination is low because much of the true uncertainty about the target was bought down by accurately modeling the target. This is beneficial since, as seen in [8] and [9], by reducing the process noise, the radar system can illuminate less frequently. Thus, by using a more accurate model of the target and reducing process noise, the radar system needs less spectral access which is beneficial for cooperative radar-communications spectrum sharing.

2) *Changing Estimation Performance*: From Equation (3), we see that by improving the estimation performance or decreasing the mean-squared estimation error  $\sigma_{\text{est}}^2$ , we increase the estimation rate. By improving the estimation performance, the radar system is able to extract more information about the target, thus increasing the estimation rate. Increasing the

estimation rate in this manner, enhances the target parameter estimation quality of the radar which is always desirable.

As we have seen above, an increase or decrease in the estimation rate is neither strictly good nor bad, rather it is the manner in which the estimation rate was altered that can be beneficial or detrimental to the joint radar-communications system. If the estimation rate is decreased by lowering the process noise, then the radar system needs less spectral access which results in a less congested spectrum (aids in radar-communications spectrum sharing). However, if the process noise is arbitrarily increased by ignoring prior information (a physical predictive model, for example), then we gain more information through measurement, but the estimation performance is degraded and radar system performance is lowered. However, increasing SNR increases both the estimation rate and estimation parameter performance.

There is a trade-off between reducing radar spectral access and increasing target parameter estimation quality. On one hand reducing the estimation rate by reducing process noise frees up more of the spectrum to be used by communications systems, aiding spectrum sharing, whereas increasing the estimation rate by improving target parameter estimation quality increases the radar system performance. Accordingly, attempts should be made to maximize the estimation rate from an SNR perspective, while jointly considering estimation error performance. That is, estimation error should never be increased to increase the estimation rate, but steps to maximize the mutual information for a fixed process noise should always be taken.

## IV. JOINT RADAR-COMMUNICATIONS ACCESS

Now that we have seen both the communications user and the radar user in an information theory context, we jointly consider the systems here. We start an exposition of the multiple-access communications performance bound for two communications users as motivation to develop inner bounds on the performance of a joint radar-communications system. We then present a number of inner bounds on performance for a joint radar-communications system and the signaling schemes that are used to achieve these inner bounds. The bounds presented in this section have been previously derived in much greater detail in [2] and [4]. Furthermore, to simplify the discussion, we consider only a single radar target with delay  $\tau$  and gain-propagation-cross-section product  $a$ . Additionally, we employ a blending ratio,  $\alpha$ , to regulate radar-communications sharing in the temporal or spectral dimension.

### A. Multiple-Access Communications Performance Bound

We consider a scenario in which the channel propagation gain for the first communications system is given by  $a_1$  and channel propagation gain for the second communications system is given by  $a_2$ . The power of the first communications transmitter is denoted by  $P_1$  and the power of the second communications transmitter is given by  $P_2$ . The scenario under consideration is shown in Figure 3.

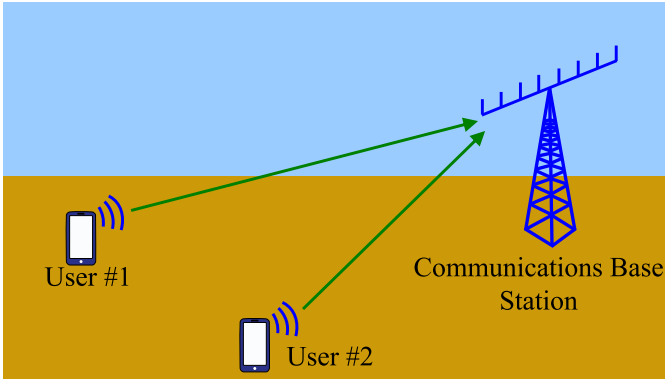

Fig. 3. Physical multiple access communications system scenario with 2 users. It is assumed both users are occupying the same bandwidth, and their space-time converge at the communications base station. As a result, their communication rates must be considered jointly.

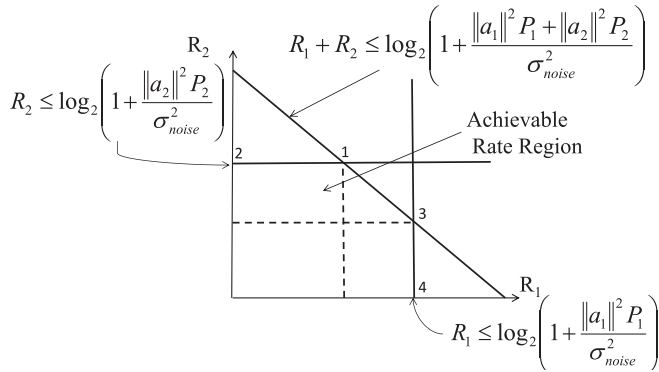

Fig. 4. Pentagon containing two-user communications multiple-access achievable rate region. Lines 1,2 and 3,4 are the rates achieved considering each communications user in an isolated bandwidth. The bisecting diagonal is the joint achievable rate. As a result, the convex hull of the three lines constructs the achievable region of two-user communications within a given shared bandwidth [4, Fig. 2].

Their corresponding rates are denoted  $R_1$  and  $R_2$ . Assuming that the noise variance is given by  $\sigma_{\text{noise}}^2$ , fundamental limits on the communications rate are shown in Figure 4. Vertices are found by jointly solving the two bounds to get [2], [4],

$$\{R_1, R_2\} = \left\{ \log_2 \left( 1 + \frac{\|a_1\|^2 P_1}{1 + \|a_2\|^2 P_2} \right), \log_2 \left( 1 + \frac{\|a_2\|^2 P_2}{\sigma_{\text{noise}}^2} \right) \right\}. \quad (7)$$

The other vertex can be found by switching the subscripts 1 and 2 in Equation (7). The region that satisfies these theoretical bounds is depicted in Figure 4. The vertices 1 and 3 shown in Figure 4 can be achieved by utilizing an optimal multiuser detection technique called Successive Interference Cancellation (SIC) [4], [56].

The achievable rate region is obtained by taking the convex hull [57] of the vertices 1-4. Because a radar signal return is not derived from a countable dictionary, the fundamental assumption of a communications signal is violated, and the bounds presented here can not be achieved by a joint radar-communications system [2]. The result presented in this

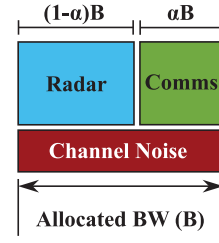

Fig. 5. Isolated sub-band bandwidth split. The noise floor is flat across the total bandwidth. The radar user and communications user are then given some complementary fraction of the overall bandwidth  $B$ , parameterized by the blending ratio  $\alpha$ .

section can be extended for more than two communications systems. For  $N$  different communications systems, the resultant achievable rate region is an  $N$ -dimensional polytope [56].

### B. Isolated Sub-Band Inner Bound

In this section, we derive an inner bound by considering a scenario in which we partition the total bandwidth into two sub-bands, one for radar only and the other for communications only, which is the standard, isolated solution. Each system functions without any interference in their respective sub-band [2], [4]. The bandwidth is split between the two sub-bands according to some blending ratio  $\alpha$  such that,

$$B = B_{\text{rad}} + B_{\text{com}}, \quad B_{\text{com}} = \alpha B, \quad B_{\text{rad}} = (1 - \alpha) B, \quad (8)$$

as shown in Figure 5. The corresponding communications rate (for the communications only sub-band) is given by

$$R_{\text{com}} \leq B_{\text{com}} \log_2 \left( 1 + \frac{\|b\|^2 P_{\text{com}}}{k_B T_{\text{temp}} B_{\text{com}}} \right), \quad (9)$$

where  $b$  is the combined gain and communications propagation loss product defined in Equation (1). The corresponding radar estimation rate is given by

$$R_{\text{est}} \leq \frac{1}{2 T_{\text{pri}}} \log_2 \left( 1 + \left( 8 \pi^2 \sigma_{\tau, \text{proc}}^2 \gamma^2 B_{\text{rad}}^2 \text{ISNR} \right) \right). \quad (10)$$

### C. Successive Interference Cancellation Inner Bound

As stated in Section III, we have some knowledge of the radar target parameter (in this case, range or time-delay) up to some range fluctuation (also called process noise). Using this information, we can generate a predicted radar return and subtract it from the joint radar-communications received signal. After suppressing the radar return, the receiver then decodes and removes the communications signal from the observed waveform to obtain a radar return signal free of communications interference. This method of interference cancellation is called SIC. SIC is the same optimal multiuser detection technique mentioned in Section IV-A, except it is now reformulated for a communications and radar user instead of two communications users. The block diagram of the joint radar-communications system considered in this scenario is shown in Figure 6.

If  $R_{\text{est}} \approx 0$  (for example, because of a low power return or well modeled target), it is as if the radar interference is not

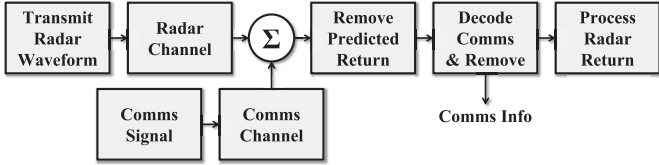

Fig. 6. Joint radar-communications system block diagram for SIC scenario. The radar and communications signals have two effective channels, but arrive converged at the joint receiver. The radar signal is predicted and removed, allowing a reduced rate communications user to operate. Assuming near perfect decoding of the communications user, the ideal signal can be reconstructed and subtracted from the original waveform, allowing for unimpeded radar access.

present and the communications system can operate at a data rate determined by the isolated communications bound,

$$R_{\text{com}} \leq B \log_2 \left( 1 + \frac{\|b\|^2 P_{\text{com}}}{k_B T_{\text{temp}} B} \right). \quad (11)$$

If the estimation rate is non-trivial, then the residual contributes to the communications system's noise floor. We can mitigate this by reducing  $R_{\text{com}}$  for a given transmit power. After subtraction of the predicted radar return, the receiver can decode the communications signal. With knowledge of the communications system, forward error correction and spectral shaping can be reapplied, and the radar system can remove the ideal communications signal from the observed waveform, leaving just the radar return. Thus, radar parameter estimation can be done without corruption from any outside interference. This implies that from the communications receiver's perspective, it observes interference plus noise as described by  $\sigma_{\text{int+n}}^2 = P_{\text{rad}} \|a\|^2 B_{\text{rms}}^2 \sigma_{\tau, \text{proc}}^2 + k_B T_{\text{temp}} B$  [2], [4], where  $a$  is the radar gain-propagation-cross-section product as defined in the beginning of Section IV, and the corresponding communications rate is given by

$$R_{\text{com}} \leq B \log_2 \left( 1 + \frac{\|b\|^2 P_{\text{com}}}{\sigma_{\text{int+n}}^2} \right). \quad (12)$$

In this regime, the corresponding estimation rate bound  $R_{\text{est}}$  is given by Equation (5). The SIC inner bound is given by connecting the points given by Equations (5), (11), and (12). This is equivalent to time sharing between full band SIC operation (normal radar, reduced communications), and communications only (no radar). In [8] and [9], the constant information radar (CIR) algorithm was developed which proposed to modulate radar spectral access based on the estimation rate measure, or more specifically, the radar estimation information,  $I(x; y)$ . The goal was to delay target revisit until an arbitrary number of bits of information about the target,  $I_{\text{const}}$ , would become available. This fixed the information rate locally around radar access, enforcing a spectral efficiency for allowing radar access. During periods when the target was well-modeled, or the SNR was low, insufficient information could be obtained, and so the communications user is allowed to broadcast freely for a longer period of time. Figure 7 shows this scheme in action. Our blending ratio  $\alpha$  now modulates radar time access or radar coherent processing interval (CPI), in which the communications user is allowed to communicate

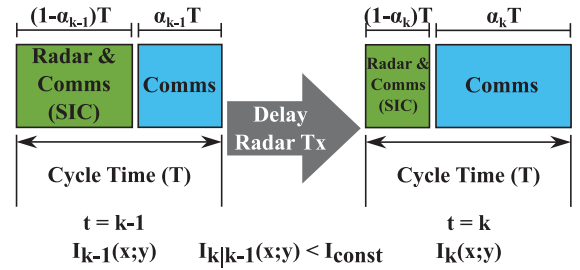

Fig. 7. Constant information radar time-sharing scheme. For the  $k^{\text{th}}$  iteration of cycle time  $T$ , part of the cycle is allocated to radar operation, where a reduced rate communications user is operating using SIC. This allocation depends on whether the radar information measure based on observations from previous cycle times,  $I_{k|k-1}(x; y)$ , is above or below a certain threshold,  $I_{\text{const}}$ . For the remainder of the cycle, the communications user is free to operate without any radar emissions. Note that the radar access time can be fixed at the duration for a single spectral access, and then the cycle time can be varied.

slower at the SIC node. Note that the radar access time or CPI can be fixed at the duration for a single spectral access, and then the cycle time can be varied.  $\alpha$  is increased when the target is well-modeled, or the SNR is low. In the former case, there is little information gained through measurement, since the target is well predicted [8], [9]. For the SNR, measurement noise dominates the entropy, and very little ‘‘good’’ information is obtained through access of the spectrum. The rates are then given by

$$\begin{aligned} R_{\text{com}} &\leq (1 - \alpha) B \log_2 \left( 1 + \frac{\|b\|^2 P_{\text{com}}}{\sigma_{\text{int+n}}^2} \right) \\ &\quad + \alpha B \log_2 \left( 1 + \frac{\|b\|^2 P_{\text{com}}}{k_B T_{\text{temp}} B} \right), \quad (13) \\ R_{\text{est}} &\leq (1 - \alpha) \frac{1}{2 T_{\text{pri}}} \log_2 \left( 1 + \left( 8 \pi^2 \sigma_{\tau, \text{proc}}^2 B_{\text{rms}}^2 \text{ISNR} \right) \right). \quad (14) \end{aligned}$$

#### D. Communications Water-Filling Bound

In this section, we consider a scenario in which the total bandwidth is split into two sub-bands, one sub-band for communications only and the other sub-band for both radar and communications. It is not necessary that the sub-bands be of equal bandwidth. We use water-filling to distribute the total communications power between the two sub-bands [2], [4]. Water-filling optimizes the power and rate allocation between multiple channels [56], [58]. The mixed use channel operates at the SIC rate vertex defined by Equations (5) and (12). The block diagram of the joint radar-communications system considered in this scenario is shown in Figure 8.

As in the isolated sub-band case, we use the blending ratio  $\alpha$  to split the overall bandwidth  $B$  into a communications only sub-band, and a mixed sub-band operating at the SIC node:

$$B = B_{\text{com}} + B_{\text{mix}}, \quad B_{\text{com}} = \alpha B, \quad B_{\text{mix}} = (1 - \alpha) B. \quad (15)$$

We then optimize the power utilization,  $\beta$ , between sub-bands,

$$P_{\text{com}} = P_{\text{CO}} + P_{\text{MU}}, \quad P_{\text{CO}} = \beta P_{\text{com}}, \quad P_{\text{MU}} = (1 - \beta) P_{\text{com}}. \quad (16)$$

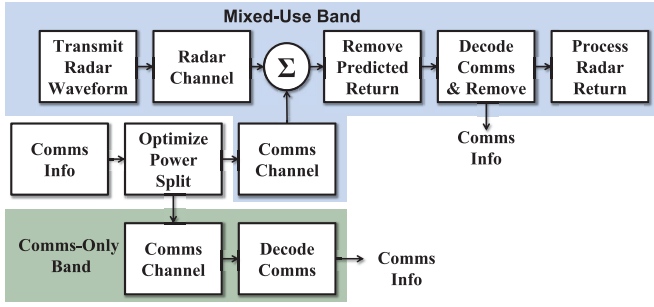

Fig. 8. Joint radar-communications system block diagram for communications only and mixed use sub-bands. One band is operating only for communications, and is spectrally isolated from the radar operation. The other sub-band is operating using SIC, where the communications and radar RF energy converge at the receiver. The optimal power split is determined using water-filling.

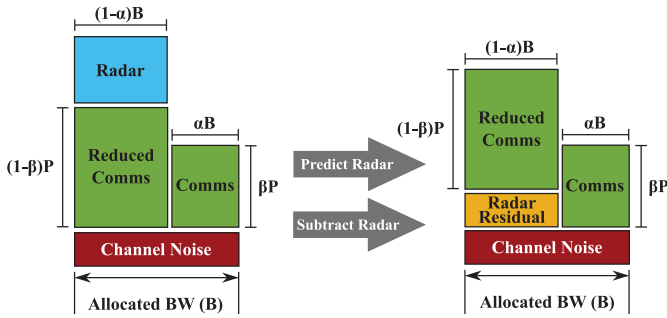

Fig. 9. Water-filling bandwidth allocation. As in the isolated sub-band case, we use our blending ratio  $\alpha$  to parameterize the allocation of bandwidth between the communications only user, and the joint radar-communications band operating using SIC. After the radar is predicted and subtracted, the mixed band has a radar residual contributing to the communications noise floor. We then have two channels with differing noise degradations, and the normal water-filling solution follows.

The water-filling power and bandwidth allocation, and the SIC algorithm are all shown in Figure 9. There are two effective channels

$$\mu_{\text{com}} = \frac{b^2}{k_B T_{\text{temp}} B_{\text{com}}}, \quad \mu_{\text{mix}} = \frac{b^2}{\sigma_{\text{int+n}}^2}, \quad (17)$$

$$\sigma_{\text{int+n}}^2 = \|\alpha\|^2 P_{\text{rad}} \gamma^2 B_{\text{mix}}^2 \sigma_{\tau, \text{proc}}^2 + k_B T_{\text{temp}} B_{\text{mix}}. \quad (18)$$

The first for the communications only channel, and the second for the mixed use channel. We apply the water-filling result derived in [2] and see that the optimal power distribution ( $\beta$ ) between the two sub-channels is given by:

$$\beta = \alpha + \frac{1}{P_{\text{com}}} \left( \frac{\alpha - 1}{\mu_{\text{com}}} + \frac{\alpha}{\mu_{\text{mix}}} \right);$$

$$\text{when } P_{\text{com}} \geq \frac{\alpha}{(1 - \alpha) \mu_{\text{mix}}} - \frac{1}{\mu_{\text{com}}}. \quad (19)$$

The resulting communications rate bound in the communications-only sub-band,  $R_{\text{com,CO}}$ , is given by

$$R_{\text{com,CO}} \leq B_{\text{com}} \log_2 \left( 1 + \frac{\beta P_{\text{com}} b^2}{k_B T_{\text{temp}} B_{\text{com}}} \right). \quad (20)$$

The mixed use communications rate inner bound,  $R_{\text{com,MU}}$ , is given by

$$R_{\text{com,MU}} \leq B_{\text{mix}} \log_2 \left( 1 + \frac{b^2 (1 - \beta) P_{\text{com}}}{\sigma_{\text{int+n}}^2} \right), \quad (21)$$

where  $\sigma_{\text{int+n}}^2$  is given by Equation (18). The corresponding radar estimation rate inner bound is then given by

$$R_{\text{est}} \leq \frac{1}{2 T_{\text{pri}}} \log_2 \left( 1 + \left( 8 \pi^2 \sigma_{\tau, \text{proc}}^2 \gamma^2 B_{\text{mix}}^2 \text{ISNR} \right) \right). \quad (22)$$

### E. Not All Bits Are Equal

As stated on numerous occasions through out this paper, the communications and estimation rates represent the amount of information, in bits, gained through the respective channels through message transmission or radar illumination. However, the bits that are used to represent the amount of information gained for each system can be prioritized differently and the information rate metrics do not clearly highlight this.

For the multiple-access communications system described previously, an increase in performance by 1 bit for the first communications system may not be as critical as an increase in performance by 1 bit for the second communications system and vice versa. For example, in Figure 4, if the first communications system with rate  $R_1$  represents a user receiving an emergency broadcast message and the second communications system with rate  $R_2$  represents a local Wi-Fi network connection, an increase in  $R_1$  by 1 bit is more critical than a similar improvement in  $R_2$ .

A similar case exists for joint radar-communications systems as well. As we see in the next section, we can use the estimation rate to generate achievable rate regions for the joint radar-communications system, such as in Figure 4. The bits used by the radar system can have more value or priority than the bits used by the communications system and vice versa.

Another consequence of the bits not being equal is that there is an intrinsic disparity in power required to increase the estimation rate by 1 bit when compared to the communications rate. A bit of higher value (or priority) may require more power for a 1 bit performance increase when compared to the other system.

For example, in Figure 10, consider a joint radar-communications system in which the communications system is used to stream a video and the radar system is monitoring air-traffic. An increase in the communications rate by 1 bit is not as critical as a similar improvement in the estimation rate. As highlighted by the examples provided in this discussion, the importance of bits are application specific. As shown in Section V-A, a system engineer can assign priorities to bits for different systems and use the complete profile of achievable rate regions, such as the ones provided by Figures 4 and 10, to determine the operating point for a joint radar-communications system which is the set of appropriate rates for each system.

The importance of this concept is further emphasized when looking at the weighted spectral efficiency of various inner bounds on performance against the blending ratio,  $\alpha$  in order to find the optimal operating point for both systems, as is done in Section V-B. The weighted spectral efficiency, which



TABLE I  
PARAMETERS FOR EXAMPLE PERFORMANCE BOUND

Parameter	Value
Bandwidth ( $B$ )	5 MHz
Center Frequency	3 GHz
Effective Temperature ( $T_{\text{temp}}$ )	1000 K
Communications Range	10 km
Communications Power ( $P_{\text{com}}$ )	0.3 W
Communications Antenna Gain	0 dBi
Radar Target Range	200 km
Radar Antenna Gain	30 dBi
Radar Power ( $P_{\text{rad}}$ )	100 kW
Target Cross Section	10 m <sup>2</sup>
Target Process Standard Deviation ( $\sigma_{\tau, \text{proc}}$ )	100 m
Time-Bandwidth Product ( $T_{\text{pulse}} B$ )	100
Radar Duty Factor ( $\delta$ )	0.01

is just a linear combination of the communications and estimation rate, can be modified to account for disparate priorities between a communications and estimation bit. Assigning different priorities to radar and communications bits alters the optimal or most spectrally efficient operating point for joint radar-communications differently. Thus, by assigning incorrect priorities, both systems could be operating in a spectrally inefficient manner thereby wasting precious spectral resources.

## V. EXAMPLES

Here we demonstrate the joint radar-communications multiple access information bounds for the basic multiple-access scenario for a given parameter set. We go over the key parameters, and present the multiple-access bounds similar to previous works [2], [3], [7]. In order to make a fair comparison, we then plot the weighted spectral efficiencies for the inner bounds using the cooperative/co-designed techniques, and the equivalent isolated solution. It should be noted that the spectral isolation bound that is plotted in Figures 10, 12, and 13 is a simple, unachievable outer bound that corresponds to each system utilizing the full bandwidth with out the presence of each other, given by Equations (9) and (10) with  $\alpha = 1$  and 0 respectively.

### A. Comparison of Joint Radar-Communications Performance Bounds

In Figure 10, we display an example of the inner bounds on performance. The parameters used in the example are displayed in Table I. In general, the inner bound is produced by the convex hull of all contributing inner bounds. There are some important subtleties with this figure. For example, the CIR time sharing scheme shows a linear interpolation between the full bandwidth SIC node, and the radar free operation (communications only). While it shows a linear decrease in estimation rate, for any given radar spectrum-space-time access, the radar is operating over the full bandwidth, unimpeded by the communications user. Contrast that with the isolated sub-band (ISB), where traveling along the curve toward the communications only axis implies a reduction in radar bandwidth, which impacts specific radar parameter estimation [59]. The same applies for water-filling. Finally, it should be stated that the performance bound curves are

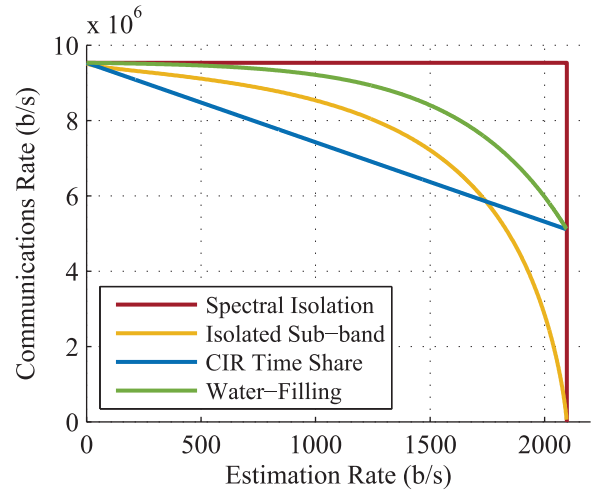

Fig. 10. Multiple access bounds for joint radar-communications access. The red lines, given by Equations (1) and (3), are created by considering each user independently in the entire bandwidth, without interference. The isolated sub-band, given by Equations (9) and (10), is represented by the yellow line, where the blending ratio  $\alpha$  is swept from 0 to 1, which allocates the overall bandwidth  $B$  proportionally to the radar or communications user. The constant information time share line is represented by the solid blue linear interpolation between the SIC node, given by Equations (5) and (12), and the radar-free communications point, given by Equation (11). Finally, the optimal water-filling solution, given by Equations (20) to (22), is represented by the solid green line. The proportion of  $B$  allocated to communications only and the mixed-use SIC band is swept with  $\alpha$ .

obtained by sweeping the blending ratio,  $\alpha$  from 0 to 1. Changing the blending ratio alters the operating point of a joint radar-communications system along the performance bound curves shown in Figure 10.

The concept that not all bits are equal discussed in Section IV-E can also be used to find the appropriate operating point for a joint radar-communications system from a complete profile of achievable rate regions such as the one shown in Figure 10. By assigning suitable weights to radar and communications bits, plotting this information against the complete profile of achievable rate regions indicates the appropriate operating point for the given joint system. This process is further highlighted in Figure 11, where we show two cases, one in which a radar bit is worth 10000 communications bits and another where a radar bit is worth 4000 communications bits. The two lines indicate on each inner bound what the appropriate operating points are for each radar bit weight case.

### B. Weighted Spectral Efficiency of Joint Radar-Communications Performance Bounds

The plots shown in Figures 10 and 11, while useful, does not give us a notion of how spectrally efficient we are. In Figures 12 and 13, we attempt to do a more fair comparison by looking at the weighted spectral efficiency of each bound. Here, the weighted spectral efficiency of each performance bound is given by

$$E_{\text{weighted}} = \frac{w_R R_{\text{est}} + w_C R_{\text{com}}}{(w_R + w_C) B_{\text{tot}}}, \quad (23)$$

where  $w_R$  is the radar bit weight,  $w_C$  is the communications bit weight, and  $B_{\text{tot}}$  is the sum of all the bandwidth consumed.

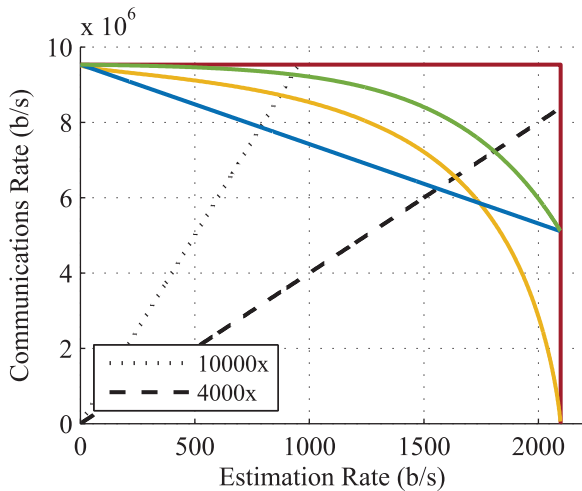

Fig. 11. Multiple access bounds for joint radar-communications access describing operating point selection. The dashed and dotted black lines represent two cases where a radar bit is valued against a communication bit. The slopes of the dashed lines indicate how much a radar bit is worth when compared against a communication bit. In the case of the dotted line, a radar bit is worth 10000 communications bits and in the case of the dashed line, a radar bit is worth 4000 communications bits. The solid lines depict the performance bounds shown in Figure 10. The intersection of a dashed line against a performance bound indicates the appropriate operating point for a given radar bit weight.

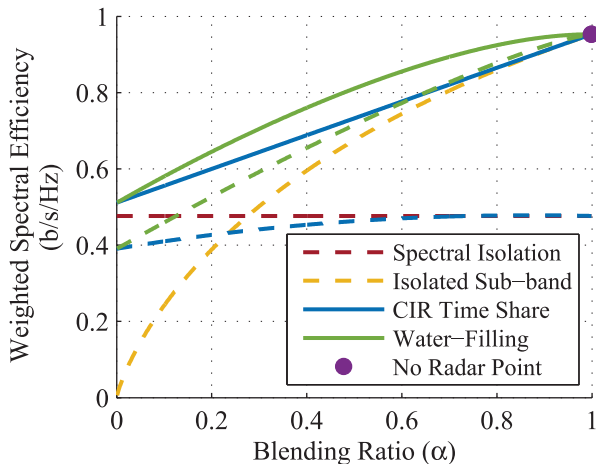

Fig. 12. Weighted spectral efficiency plots for joint radar-communications access. Note the accompanying colored dashed lines are the equivalent, isolated weighted spectral efficiencies. For example, the dashed blue line is the weighted spectral efficiency obtained if the two systems were operating at the same rate given by the CIR time share scheme in the solid blue line, but isolated in frequency. This means the communications user that is operating after subtraction of the radar would be in its own equivalent band.

In Figures 12 and 13, we look at the weighted spectral efficiency of the performance bounds discussed in Section IV for co-designed systems as well as their respective equivalent, isolated systems (spectrally isolated systems operating at the same rates) for a given spectral allocation,  $B$ . For these isolated systems, the total consumed bandwidth,  $B_{\text{tot}}$  is given by

$$B_{\text{tot}} = B + B_{\text{eff}}, \quad (24)$$

where  $B$  is the bandwidth consumed by an isolated radar system and  $B_{\text{eff}}$  is the effective bandwidth required by an isolated

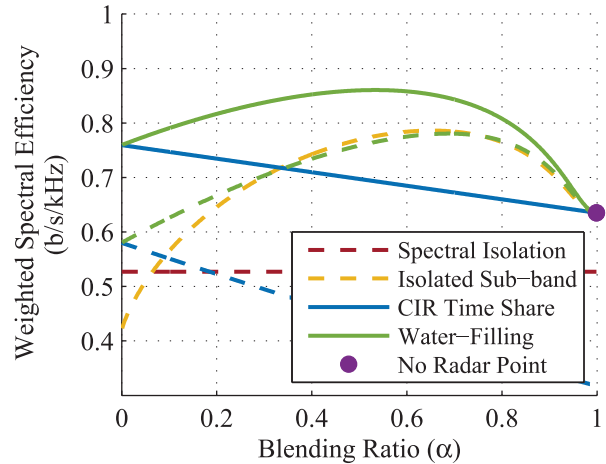

Fig. 13. Weighted spectral efficiency (measured here in bits per second per kilohertz) plots for joint radar-communications access, weighted for importance. In this example, we weighted the radar bits 3000x what the communications bits are worth. This may be true for certain military radar applications, and the weighting may be scenario dependent. With proper weighting, the maximum point of spectral efficiency has more meaning and utility.

communications system to achieve the same communications rate as a co-designed system. For the CIR time sharing scheme, we solve for the effective isolated bandwidth by solving

$$B_{\text{eff}} = R_{\text{com}}^{-1}(\alpha R_{\text{com,free}} + (1 - \alpha)R_{\text{com,sic}}), \quad (25)$$

where  $R_{\text{com,free}}$  is the communications rate when there are no other users given by Equation (11), and  $R_{\text{com,sic}}$  is the reduced communications rate operating at the SIC node, given by Equation (12). That is, we solve for  $B$  in Equation (11), given that the left hand side is equal to the total communications rate for a given point along the CIR time share line. This is the sum of the duty-cycled communications only rate given by Equation (11), and the complementary duty-cycled SIC communications rate operating after radar prediction subtraction given by Equation (12). We utilize a similar technique for the water-filling scenario.

To emphasize the importance of the concept that not all bits are equal that was discussed in great detail in Section IV-E, we assign both the radar and communications bits a weight of 1 and calculate the weighted spectral efficiency, as shown in Figure 12. Here, with solid and dashed lines representing the co-designed system and the equivalent isolated system (systems operating at same rates but isolated in frequency) respectively, we see that cooperation outperforms isolation for this case and that the water-filling bound is most spectrally efficient. However, on recognizing that the blending ratio  $\alpha$  is the  $x$ -axis for this plot, it then becomes clear that the peak of this plot is not the optimal operating point, given that  $\alpha = 1$  implies no radar use. Since both radar and communications bits are assigned equal priorities of 1 in this scenario, it is evident that not all bits are equal in this optimization process. We can underscore this by setting  $w_R = 3000$  and  $w_C = 1$  in Equation (23), as shown in Figure 13. With proper

weighting, the maximum in this plot becomes more meaningful when considering spectral allocation. It should be noted that since the radar bits are weighted 3000x what the communications bits are worth, this implies that more power may be required to increase the estimation rate as compared to the communications data rate.

## VI. CONCLUSION

In this paper, we describe the problem of radar communications coexistence and describe the challenges in achieving radar communications RF convergence. We perform a survey of previously proposed solutions and by considering the RF convergence problem as a joint information problem, we present a novel approach to constructing future solutions. We develop multiple solutions to cooperative radar and communications coexistence for a simple multi-access scenario, which can be applied to more complicated scenarios. We discuss our choice of information as a joint performance metric and present a novel parameterization of the radar in terms of target information gained through radar illumination, the estimation rate. We see how the estimation rate is a metric analogous to the communications data rate. We also note how the information measured by the estimation and communications rate in bits for each system can have different values or priority, depending on the importance of each system. Using the estimation rate and the communications data rate, we then develop several cooperative signaling schemes that are used to develop inner bounds on joint performance. Finally, we compare the weighted spectral efficiency of various bounds on performance as well traditional solutions to the RF convergence problem, such as complete spectral isolation, and observe that cooperative and co-design techniques provide high spectral efficiency and outperform traditional solutions.

## ACKNOWLEDGMENT

The views expressed are those of the authors and do not reflect the official policy or position of the Department of Defense or the U.S. Government.

## REFERENCES

- [1] H. Griffiths *et al.*, "Radar spectrum engineering and management: Technical and regulatory issues," *Proc. IEEE*, vol. 103, no. 1, pp. 85–102, Jan. 2015.
- [2] D. W. Bliss, "Cooperative radar and communications signaling: The estimation and information theory odd couple," in *Proc. IEEE Radar Conf.*, Cincinnati, OH, USA, May 2014, pp. 50–55.
- [3] B. Paul and D. W. Bliss, "Extending joint radar-communications bounds for FMCW radar with Doppler estimation," in *Proc. IEEE Radar Conf.*, Arlington County, VA, USA, May 2015, pp. 89–94.
- [4] A. R. Chiriyath, B. Paul, G. M. Jacyna, and D. W. Bliss, "Inner bounds on performance of radar and communications co-existence," *IEEE Trans. Signal Process.*, vol. 64, no. 2, pp. 464–474, Jan. 2016.
- [5] A. R. Chiriyath and D. W. Bliss, "Effect of clutter on joint radar-communications system performance inner bounds," in *Proc. 49th Asilomar Conf. Signals Syst. Comput.*, Pacific Grove, CA, USA, Nov. 2015, pp. 1379–1383.
- [6] A. R. Chiriyath, B. Paul, and D. W. Bliss, "Joint radar-communications information bounds with clutter: The phase noise menace," in *Proc. IEEE Radar Conf.*, Philadelphia, PA, USA, May 2016, pp. 690–695.
- [7] A. R. Chiriyath and D. W. Bliss, "Joint radar-communications performance bounds: Data versus estimation information rates," in *Proc. IEEE Mil. Commun. Conf. (MILCOM)*, Tampa, FL, USA, Oct. 2015, pp. 1491–1496.
- [8] B. Paul and D. W. Bliss, "Constant information radar for dynamic shared spectrum access," in *Proc. 49th Asilomar Conf. Signals Syst. Comput.*, Pacific Grove, CA, USA, Nov. 2015, pp. 1374–1378.
- [9] B. Paul and D. W. Bliss, "The constant information radar," *Entropy*, vol. 18, no. 9, p. 338, 2016. [Online]. Available: <http://www.mdpi.com/1099-4300/18/9/338>
- [10] B. Paul, A. R. Chiriyath, and D. W. Bliss, "Joint communications and radar performance bounds under continuous waveform optimization: The waveform awakens," in *Proc. IEEE Radar Conf.*, Philadelphia, PA, USA, May 2016, pp. 865–870.
- [11] B. Paul and D. W. Bliss, "Estimation information bounds using the I-MMSE formula and Gaussian mixture models," in *Proc. 50th Annu. Conf. Inf. Sci. Syst. (CISS)*, Princeton, NJ, USA, Mar. 2016, pp. 292–297.
- [12] D. Guo, S. Shamai, and S. Verdú, *The Interplay Between Information and Estimation Measures* (Foundations and Trends in Signal Processing). Boston, MA, USA: Now, 2012.
- [13] B. Paul, A. R. Chiriyath, and D. W. Bliss, "Survey of RF communications and sensing convergence research," *IEEE Access*, vol. 5, pp. 1–19, 2017.
- [14] C. Sturm and W. Wiesbeck, "Waveform design and signal processing aspects for fusion of wireless communications and radar sensing," *Proc. IEEE*, vol. 99, no. 7, pp. 1236–1259, Jul. 2011.
- [15] A. Turlapaty, Y. Jin, and Y. Xu, "Range and velocity estimation of radar targets by weighted OFDM modulation," in *Proc. IEEE Radar Conf.*, Cincinnati, OH, USA, May 2014, pp. 1358–1362.
- [16] T. Guo and R. Qiu, "OFDM waveform design compromising spectral nulling, side-lobe suppression and range resolution," in *Proc. IEEE Radar Conf.*, Cincinnati, OH, USA, May 2014, pp. 1424–1429.
- [17] G. Lellouch, A. Mishra, and M. Inggs, "Impact of the Doppler modulation on the range and Doppler processing in OFDM radar," in *Proc. IEEE Radar Conf.*, Cincinnati, OH, USA, May 2014, pp. 803–808.
- [18] S. C. Thompson and J. P. Stralka, "Constant envelope OFDM for power-efficient radar and data communications," in *Proc. Int. Waveform Diversity Design Conf.*, Kissimmee, FL, USA, Feb. 2009, pp. 291–295.
- [19] J. R. Krier *et al.*, "Performance bounds for an OFDM-based joint radar and communications system," in *Proc. IEEE Mil. Commun. Conf.*, Tampa, FL, USA, Oct. 2015, pp. 511–516.
- [20] G. Hakobyan and B. Yang, "A novel OFDM-MIMO radar with non-equidistant subcarrier interleaving and compressed sensing," in *Proc. 17th Int. Radar Symp. (IRS)*, Kraków, Poland, May 2016, pp. 1–5.
- [21] Y. L. Sit, B. Nuss, S. Basak, M. Orzol, and T. Zwick, "Demonstration of interference cancellation in a multiple-user access OFDM MIMO radar-communication network using USRPs," in *Proc. IEEE MTT-S Int. Conf. Microw. Intell. Mobility (ICMIM)*, San Diego, CA, USA, May 2016, pp. 1–4.
- [22] X. Shaojian, C. Bing, and Z. Ping, "Radar-communication integration based on DSSS techniques," in *Proc. 8th Int. Conf. Signal Process.*, vol. 4. Beijing, China, Nov. 2006, pp. 1–4.
- [23] Y. Xie, R. Tao, and T. Wang, "Method of waveform design for radar and communication integrated system based on CSS," in *Proc. 1st Int. Conf. Instrum. Meas. Comput. Commun. Control*, Beijing, China, Oct. 2011, pp. 737–739.
- [24] M. Robertson and E. R. Brown, "Integrated radar and communications based on chirped spread-spectrum techniques," in *Proc. IEEE MTT-S Int. Microw. Symp. Dig.*, vol. 1. Philadelphia, PA, USA, Jun. 2003, pp. 611–614.
- [25] A. Khawar, A. Abdel-Hadi, and T. C. Clancy, "MIMO radar waveform design for coexistence with cellular systems," in *Proc. IEEE Int. Symp. Dyn. Spectr. Access Netw. (DYSPAN)*, McLean, VA, USA, Apr. 2014, pp. 20–26.
- [26] Y. L. Sit and T. Zwick, "MIMO OFDM radar with communication and interference cancellation features," in *Proc. IEEE Radar Conf.*, Cincinnati, OH, USA, May 2014, pp. 265–268.
- [27] B. Li, A. P. Petropulu, and W. Trappe, "Optimum co-design for spectrum sharing between matrix completion based MIMO radars and a MIMO communication system," *IEEE Trans. Signal Process.*, vol. 64, no. 17, pp. 4562–4575, Sep. 2016.
- [28] A. Khawar, A. Abdel-Hadi, and T. C. Clancy, "Spectrum sharing between S-band radar and LTE cellular system: A spatial approach," in *Proc. IEEE Int. Sympo. Dyn. Spectr. Access Netw. (DYSPAN)*, McLean, VA, USA, Apr. 2014, pp. 7–14.
- [29] S. Sodagari, A. Khawar, T. C. Clancy, and R. McGwier, "A projection based approach for radar and telecommunication systems coexistence," in *Proc. IEEE Glob. Commun. Conf. (GLOBECOM)*, Anaheim, CA, USA, Dec. 2012, pp. 5010–5014.

- [30] H. Shajaiah, A. Abdelhadi, and C. Clancy, "Spectrum sharing approach between radar and communication systems and its impact on radar's detectable target parameters," in *Proc. IEEE 81st Veh. Technol. Conf. (VTC Spring)*, Glasgow, U.K., May 2015, pp. 1–6.
- [31] G. N. Saddik, R. S. Singh, and E. R. Brown, "Ultra-wideband multifunctional communications/radar system," *IEEE Trans. Microw. Theory Techn.*, vol. 55, no. 7, pp. 1431–1437, Jul. 2007.
- [32] R. Saruthirathanaworakun, J. M. Peha, and L. M. Correia, "Opportunistic sharing between rotating radar and cellular," *IEEE J. Sel. Areas Commun.*, vol. 30, no. 10, pp. 1900–1910, Nov. 2012.
- [33] F. Paisana, J. P. Miranda, N. Marchetti, and L. A. DaSilva, "Database-aided sensing for radar bands," in *Proc. IEEE Int. Symp. Dyn. Spectr. Access Netw. (DYSpan)*, McLean, VA, USA, Apr. 2014, pp. 1–6.
- [34] A. Lackpour, M. Luddy, and J. Winters, "Overview of interference mitigation techniques between WiMAX networks and ground based radar," in *Proc. 20th Annu. Wireless Opt. Commun. Conf.*, Newark, NJ, USA, Apr. 2011, pp. 1–5.
- [35] H. Shajaiah, A. Khawar, A. Abdel-Hadi, and T. C. Clancy, "Resource allocation with carrier aggregation in LTE advanced cellular system sharing spectrum with S-band radar," in *Proc. IEEE Int. Symp. Dyn. Spectr. Access Netw. (DYSpan)*, McLean, VA, USA, Apr. 2014, pp. 34–37.
- [36] J. R. Guerci and R. M. Guerci, "RAST: Radar as a subscriber technology for wireless spectrum cohabitation," in *Proc. IEEE Radar Conf.*, Cincinnati, OH, USA, May 2014, pp. 1130–1134.
- [37] Y. Nijsure, Y. Chen, C. Yuen, and Y. H. Chew, "Location-aware spectrum and power allocation in joint cognitive communication-radar networks," in *Proc. 6th Int. ICST Conf. Cogn. Radio Orient. Wireless Netw. Commun. (CROWNCOM)*, Yokohama, Japan, Jun. 2011, pp. 171–175.
- [38] A. Aubry *et al.*, "Cognitive radar waveform design for spectral coexistence in signal-dependent interference," in *Proc. IEEE Radar Conf.*, Cincinnati, OH, USA, May 2014, pp. 474–478.
- [39] K.-W. Huang, M. Bicá, U. Mitra, and V. Koivunen, "Radar waveform design in spectrum sharing environment: Coexistence and cognition," in *Proc. IEEE Radar Conf.*, Arlington County, VA, USA, May 2015, pp. 1698–1703.
- [40] J. Jakabosky, B. Ravenscroft, S. D. Blunt, and A. Martone, "Gapped spectrum shaping for tandem-hopped radar/communications & cognitive sensing," in *Proc. IEEE Radar Conf. (RadarConf)*, Philadelphia, PA, USA, May 2016, pp. 1–6.
- [41] M. Bica, K.-W. Huang, V. Koivunen, and U. Mitra, "Mutual information based radar waveform design for joint radar and cellular communication systems," in *Proc. IEEE Int. Conf. Acoust. Speech Signal Process. (ICASSP)*, Pudong, China, Mar. 2016, pp. 3671–3675.
- [42] J. M. Chapin and W. H. Lehr, "Cognitive radios for dynamic spectrum access—The path to market success for dynamic spectrum access technology," *IEEE Commun. Mag.*, vol. 45, no. 5, pp. 96–103, May 2007.
- [43] W. Zhang, S. Vedantam, and U. Mitra, "Joint transmission and state estimation: A constrained channel coding approach," *IEEE Trans. Inf. Theory*, vol. 57, no. 10, pp. 7084–7095, Oct. 2011.
- [44] S. Howard, W. Moran, A. R. Calderbank, H. Schmitt, and C. Savage, "Channel parameters estimation for cognitive radar systems," in *Proc. IEEE Int. Conf. Acoust. Speech Signal Process.*, vol. 5, Philadelphia, PA, USA, Mar. 2005, pp. 897–900.
- [45] A. Pezeshki, A. R. Calderbank, W. Moran, and S. D. Howard, "Doppler resilient Golay complementary waveforms," *IEEE Trans. Inf. Theory*, vol. 54, no. 9, pp. 4254–4266, Sep. 2008.
- [46] B. Li and A. Petropulu, "MIMO radar and communication spectrum sharing with clutter mitigation," in *Proc. IEEE Radar Conf. (RadarConf)*, Philadelphia, PA, USA, May 2016, pp. 1–6.
- [47] A. Hassanien, M. G. Amin, Y. D. Zhang, F. Ahmad, and B. Himed, "Non-coherent PSK-based dual-function radar-communication systems," in *Proc. IEEE Radar Conf. (RadarConf)*, Philadelphia, PA, USA, May 2016, pp. 1–6.
- [48] A. Hassanien, M. G. Amin, Y. D. Zhang, and F. Ahmad, "Dual-function radar-communications: Information embedding using sidelobe control and waveform diversity," *IEEE Trans. Signal Process.*, vol. 64, no. 8, pp. 2168–2181, Apr. 2016.
- [49] E. BouDaher, A. Hassanien, E. Aboutanos, and M. G. Amin, "Towards a dual-function MIMO radar-communication system," in *Proc. IEEE Radar Conf. (RadarConf)*, Philadelphia, PA, USA, May 2016, pp. 1–6.
- [50] D. Gaglione *et al.*, "Fractional Fourier based waveform for a joint radar-communication system," in *Proc. IEEE Radar Conf. (RadarConf)*, Philadelphia, PA, USA, May 2016, pp. 1–6.
- [51] C. Shannon, "A mathematical theory of communication," *Bell Syst. Tech. J.*, vol. 27, no. 3, pp. 379–423 and pp. 623–656, Jul./Oct. 1948.
- [52] P. M. Woodward, "Information theory and the design of radar receivers," *Proc. IRE*, vol. 39, no. 12, pp. 1521–1524, Dec. 1951.
- [53] M. R. Bell, "Information theory and radar waveform design," *IEEE Trans. Inf. Theory*, vol. 39, no. 5, pp. 1578–1597, Sep. 1993.
- [54] J. R. Guerci, R. M. Guerci, A. Lackpour, and D. Moskowitz, "Joint design and operation of shared spectrum access for radar and communications," in *Proc. IEEE Radar Conf.*, Arlington County, VA, USA, May 2015, pp. 761–766.
- [55] R. A. Romero and N. A. Goodman, "Cognitive radar network: Cooperative adaptive beamsteering for integrated search-and-track application," *IEEE Trans. Aerosp. Electron. Syst.*, vol. 49, no. 2, pp. 915–931, Apr. 2013.
- [56] T. M. Cover and J. A. Thomas, *Elements of Information Theory*, 2nd ed. Hoboken, NJ, USA: Wiley, 2006.
- [57] M. de Berg, O. Cheong, M. van Kreveld, and M. Overmars, *Computational Geometry: Algorithms and Applications*, 3rd ed. Heidelberg, Germany: Springer-Verlag, 2008.
- [58] D. W. Bliss and S. Govindasamy, *Adaptive Wireless Communications: MIMO Channels and Networks*. New York, NY, USA: Cambridge Univ. Press, 2013.
- [59] H. L. Van Trees, *Detection, Estimation, and Modulation Theory: Radar-Sonar Signal Processing and Gaussian Signals in Noise*. Malabar, FL, USA: Krieger, Jul. 1992.



**Alex R. Chiriyath** received the B.S.E.E. (*Cum Laude*) degree in electrical engineering from the University of Michigan at Ann Arbor in 2012, and the M.S. degree in electrical engineering from Arizona State University in 2014, where he is currently pursuing the Ph.D. degree in electrical engineering.



**Bryan Paul** received the B.S. (Highest Hons.) degree in electrical engineering from the University of Illinois at Urbana-Champaign in 2010, and the M.S. degree in electrical engineering from Arizona State University in 2014, where he is currently pursuing the Ph.D. degree with the School of Electrical, Computer and Energy Engineering.

From 2002 to 2008, he was enlisted in the Illinois Air National Guard completing multiple tours of duty in support of Operation Enduring Freedom and Operation Iraqi Freedom. From 2010 to 2012, he was with Validus Technologies, Peoria, IL, USA, working in the area of embedded software and digital signal processing. He is currently with General Dynamics Mission Systems, Scottsdale, AZ, USA, working in the area of digital signal processing for satellite payload systems. His current research interests include signal processing, information theory, radar, and communications.

He was a recipient of numerous military decorations, including the Humanitarian Service Medal. He is a co-inventor of one awarded U.S. patent.



**Daniel W. Bliss** (F'15) received the B.S.E.E. degree in electrical engineering from Arizona State University in 1989, and the M.S. degree in physics and the Ph.D. degree from the University of California at San Diego in 1995 and 1997, respectively. He was employed by General Dynamics from 1989 to 1993, where he designed rocket avionics and performed magnetic field calculations and optimization for high-energy particle-accelerator superconducting magnets. His doctoral work (1993–1997) was in the area of high-energy particle physics. He

was a senior member of the technical staff with MIT Lincoln Laboratory from 1997 to 2012. He is currently an Associate Professor with the School of Electrical, Computer and Energy Engineering, Arizona State University. His current research topics include multiple-input multiple-output (MIMO) wireless communications, MIMO radar, cognitive radios, radio network performance, geolocation, and statistical signal processing for anticipatory physiological analytics. He has been the Principal Investigator on numerous programs with applications to radio, radar, and medical monitoring. He has made significant contributions to robust multiple-antenna communications, including theory, patents, and the development of advanced prototypes. He is responsible for some of the foundational MIMO radar literature.