

Letters

A Hybrid Power Control Concept for PV Inverters With Reduced Thermal Loading

Yongheng Yang, *Student Member, IEEE*, Huai Wang, *Member, IEEE*, Frede Blaabjerg, *Fellow, IEEE*, and Tamas Kerekes, *Member, IEEE*

Abstract—This letter proposes a hybrid power control concept for grid-connected photovoltaic (PV) inverters. The control strategy is based on either a maximum power point tracking control or a constant power generation (CPG) control depending on the instantaneous available power from the PV panels. The essence of the proposed concept lies in the selection of an appropriate power limit for the CPG control to achieve an improved thermal performance and an increased utilization factor of PV inverters, and thus, to cater for a higher penetration level of PV systems with intermittent nature. A case study on a single-phase PV inverter under yearly operation is presented with analyses of the thermal loading, lifetime, and annual energy yield. It has revealed the trade-off factors to select the power limit and also verified the feasibility and the effectiveness of the proposed control concept.

Index Terms—Constant power generation (CPG), efficiency, maximum power point tracking (MPPT), photovoltaic (PV) inverters, reliability, thermal loading.

I. INTRODUCTION

MAXIMUM power point tracking (MPPT) is effective for photovoltaic (PV) inverters to maximize the energy harvested from PV panels [1]. However, with increasing installations of PV systems into the grid, the following issues appear if the inverters keep operation at MPPT mode even within the rated power range: 1) overloading of the grid at peak power generation [2] which may induce system level over-voltage and line frequency instability [3]; 2) limited utilization of the PV inverters, since they operate at relatively low power level with respect to the designed power rating during most of long-term field operations; 3) high temperature peaks and variations on switching devices due to the intermittency, which accelerates the degradation of the switching devices [4].

To tackle the overloading issue, expanding the grid infrastructure [5] (e.g., transformers, conductors) and integrating energy storage elements [6] are two of the solutions. However, as reported in [7], the expenses increased by grid expansion may severely exceed the initial project outlay. The energy storage elements are mostly installed at the substation side instead of in

the individual inverters also considering cost and maintenance. Since the aforementioned solutions introduce considerable investments, two kinds of hybrid control concepts have been proposed in prior-art research. In [3], an MPPT control with a reduced power mode control has been introduced to avoid dynamic overloading in a stand-alone wind-PV generation system. The selection of the power limit for the reduced power mode control is dynamically in accordance to the power oscillations during wind turbine soft stalling. The reduced power mode operation is achieved by modifying the MPPT algorithm based on a virtual MPPT. In [8], an MPPT control with power curtailment control is proposed to prevent over-voltage of low voltage feeders by limiting the excessive power injection to the grid from PV inverters. The selection of the power limit for the power curtailment control depends on the upper voltage limit of the low voltage feeders. These control concepts can effectively avoid the over-loading issue with an acceptable reduction of the overall energy generation [9]. However, the issue on the utilization of PV inverter remains and the thermal performance of the PV inverters is still unknown.

This letter therefore proposes a hybrid power control concept with the objective to improve the thermal performance and increase the utilization factor of PV inverters. It has the following features: 1) a constant power generation (CPG) control mode is activated by using a direct power control when the dc power from PV panels reaches to a specific limit, the value of which depends on the trade-offs of thermal loading (therefore lifetime) of switching devices, PV inverter utilization factor, and annual energy yield under yearly mission profiles (i.e., solar irradiance and ambient temperature). It should be noted that the selection of this power limit is different from those in [3] and [8] as discussed above. 2) The MPPT mode is active when the dc power is below the specific power level. The proposed MPPT-CPG control concept allows a reduction of required power ratings of PV inverters and also a reduction of junction temperature peaks and variations on the power devices (i.e., an extended lifetime [4], [10], [11]). Meanwhile, it could contribute to the system level power management to some extent, due to its role in smoothing and limiting the power fed into the grid. The concept, implementation, feasibility and effectiveness of the control strategy are discussed below.

II. PROPOSED HYBRID POWER CONTROL CONCEPT

The single-phase two-stage configuration is preferable for residential PV applications [1]. The control structure of a

Manuscript received April 3, 2014; revised May 21, 2014; accepted June 22, 2014. Date of publication June 25, 2014; date of current version August 13, 2014. Recommended for publication by Associate Editor H. Chung.

The authors are with the Department of Energy Technology, Aalborg University, DK-9220 Aalborg, Denmark (e-mail: yoy@et.aau.dk; hwa@et.aau.dk; fbl@et.aau.dk; tak@et.aau.dk).

Color versions of one or more of the figures in this paper are available online at <http://ieeexplore.ieee.org>.

Digital Object Identifier 10.1109/TPEL.2014.2332754

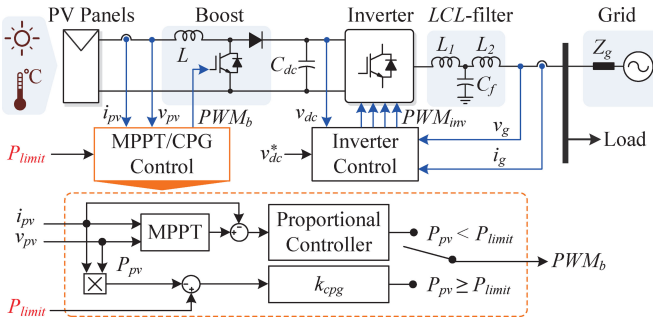

Fig. 1. Schematic and control diagram of a two-stage single-phase PV system with the proposed hybrid control concept.

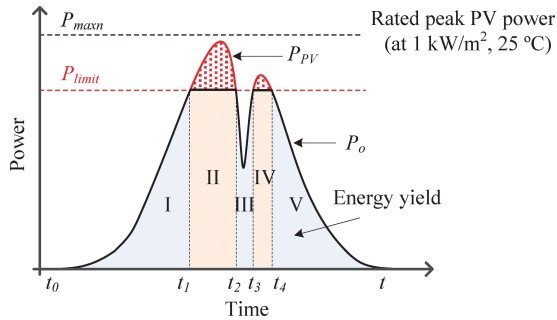

Fig. 2. Operation regions (I, III, V - MPPT; II, IV - CPG) for a single-phase PV system during a day with the proposed control strategy, where P_{limit} is determined by the tradeoffs among the device thermal performance, the inverter utilization factor, and the annual energy yield.

two-stage single-phase PV system with the proposed control concept is shown in Fig. 1, which indicates that the hybrid control strategy is implemented in the control of the boost stage. As shown in Fig. 1, depending on the instantaneous available power of the PV panels, the actual output power of the PV panels can be expressed as

$$P_o(t) = \begin{cases} P_{PV}(t), & \text{MPPT, when } P_{PV}(t) < P_{limit} \\ P_{limit}, & \text{CPG, when } P_{PV}(t) \geq P_{limit} \end{cases} \quad (1)$$

where $P_o(t)$ is the output power of the PV panels (i.e., input power of the power conversion stage), $P_{PV}(t)$ is the available maximum power of the PV panels, and P_{limit} is selected by taking into account the tradeoffs among the thermal performance (lifetime) of power devices, the PV inverter utilization factor, and the annual energy yield.

As the available PV power is weather-dependent, the operation modes will alter accordingly with the solar irradiance and ambient temperature. Fig. 2 exemplifies different operation regions for a single-phase PV system during a day with the proposed control strategy. Then, according to (1), it can be obtained that

$$\begin{cases} E_{mpp} = \int_{t_0}^t P_{PV}(t) dt \\ E_{cpg} = \int_{t_1}^{t_2} P_{limit} dt + \int_{t_3}^{t_4} P_{limit} dt \end{cases} \quad (2)$$

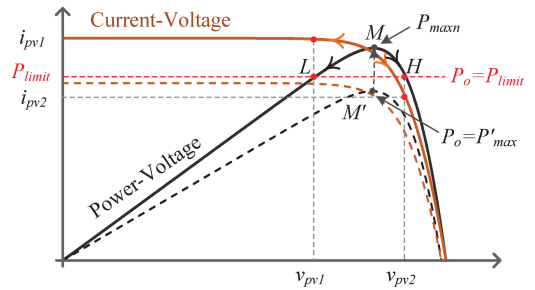

Fig. 3. PV characteristics with limiting maximum feed-in power control (solid lines – 1 kW/m² insolation; dashed lines – 0.8 kW/m² insolation).

where E_{mpp} is the available energy during a day with MPPT control, and E_{cpg} is the energy production in CPG operation mode in regions of II and IV in Fig. 2. Hereby, the “cut-off” energy (dotted-area) during the day can be given by,

$$E_{ess} = \int_{t_1}^{t_2} P_{PV}(t) dt + \int_{t_3}^{t_4} P_{PV}(t) dt - E_{cpg} \quad (3)$$

which can be adopted as a trade-off factor to determine the power limit P_{limit} as discussed later.

According to Figs. 1 and 2, and (1), the operation principle of the proposed hybrid MPPT-CPG control can be described as follows. When $P_{PV}(t) \geq P_{limit}$, the system enters into CPG operation mode and the MPPT control is deactivated. The PV output power is regulated by a proportional controller (k_{cpg}) to maintain the output power constant (i.e., $P_o(t) = P_{limit}$). When $P_{PV}(t) < P_{limit}$, the system maximizes the output power with an MPPT control, and thus the CPG control is disabled.

The CPG control can be achieved by diverting the operating point from the maximum power point. As an example illustrated in Fig. 3, if the available power of the PV panel exceeds the power limit when the solar irradiance is increased from 0.8 kW/m² to 1 kW/m², the operating point of the PV panels either moves to “L” or “H” rather than “M”. Accordingly, the operating point of the PV inverter is changed. There are three alternatives of the control variables for CPG control: v_{pv} , i_{pv} , or P_{pv} . The first two control options can be achieved on a basis of the existing power point tracking algorithms, e.g. Perturb and Observe (P&O) and incremental conductance methods [12], [13]. The third one is applied in this study by using P_{limit} as a power reference since it is relatively simple. It is worthwhile investigating the dynamic performance of different implementation methods, which is beyond the scope of this letter and is considered as a further in-depth study.

The implementation of the hybrid control concept requires an appropriate power limit (P_{limit}) as shown in Fig. 1. To quantitatively find the optimal power limit, a PV inverter utilization factor (in hours) is defined as

$$\gamma = \frac{E}{P_n} \quad (4)$$

in which E is the annual energy production and P_n is the rated maximum power of the PV inverter. Equation (4) indicates how many equivalent hours the system operates at the maximum

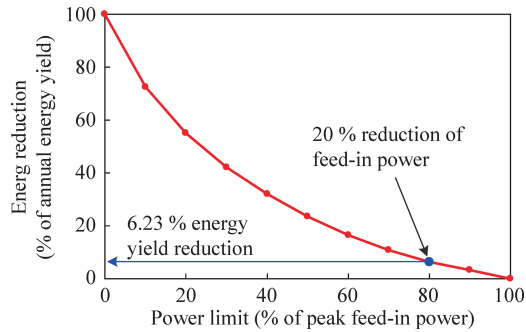

Fig. 4. Energy reduction due to the limitation of maximum feed-in power from a 3-kW grid-connected PV system using yearly real-field data.

TABLE I
PARAMETERS OF THE 3 kW TWO-STAGE SINGLE-PHASE PV SYSTEM

Parameter	Value
PV panels rated power	$P_n = 2925 \text{ W}$
Boost converter inductor	$L = 5 \text{ mH}$
DC-link capacitor	$C_{dc} = 2200 \text{ } \mu\text{F}$
LCL-filter	$L_1 = 2 \text{ mH}, L_2 = 3 \text{ mH}, C_f = 4.7 \text{ } \mu\text{F}$
Switching frequencies for boost stage and inverter	$f_{boost} = f_{inv} = 10 \text{ kHz}$
Grid nominal voltage (RMS)	$V_g = 230 \text{ V}$
Grid nominal frequency	$\omega_0 = 2\pi \times 50 \text{ rad/s}$

rated power through a year. With the proposed MPPT-CPG control, i.e. $P_n = P_{limit}$, a larger value of γ implies a relative lower cost of the PV inverters, as the ratings are reduced.

Additionally, the selection of P_{limit} should be compromised with the energy loss defined in (3). Fig. 4 presents the dependency of energy reduction on P_{limit} for a 3-kW PV system operating under a specific yearly mission profile. The energy loss is increased with the reduced value of P_{limit} . For example, a 20% reduction of the maximum feed-in power will result in a 6.23% reduction of the annual energy production. Correspondingly, the PV inverter utilization factor is increased by 17% (i.e., $\frac{1-0.0623}{0.8} - 1$). Further trade-off design factors, such as the impact on the lifetime of PV inverters and the cost-of-energy of the PV systems, are not covered in this letter.

III. OPERATION EXAMPLES

To illustrate the effectiveness of the proposed hybrid control concept, simulations of a 3-kW two-stage single-phase PV system are carried out referring to Fig. 1. The system consists of three PV strings (15 panels of each). The parameters of the system are listed in Table I. The P&O MPPT control method is adopted in the MPPT operation mode [12]. A proportional resonant controller is used in the current control loop for power quality consideration [1]. In both operation modes, the dc-link voltage is regulated within $400 \pm 5 \text{ V}$ to ensure the power injection, and the proposed power control is adopted according to Figs. 1 and 3.

Firstly, the single-phase PV system with the proposed hybrid MPPT-CPG control is tested under ramp-changes of solar irradiance at a constant ambient temperature. The results are

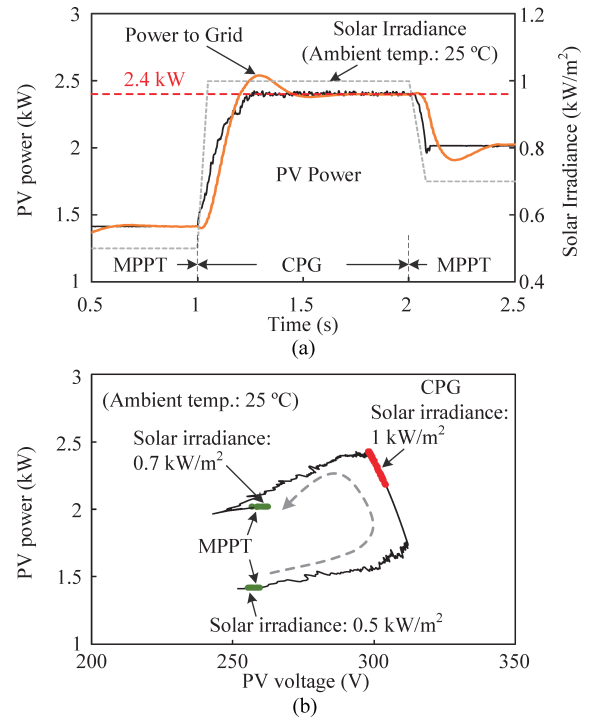

Fig. 5. Performance of the PV system with the hybrid control: (a) output power and solar irradiance profile and (b) PV power versus PV voltage.

presented in Fig. 5. It can be noted that, when the maximum power exceeds the limitation (80% of nominal power according to Fig. 4), the CPG control is activated and thus constant output power is achieved. Once the PV power goes below the limit, the system resumes MPPT operation mode. Then, the maximum power from the PV strings are fed into the grid.

Fig. 6(a) shows the output power and corresponding energy yield of the PV system with and without CPG control under two real-field daily profiles (sampling rate: 30 min per sample). According to (2) and (3), the energy yield is 94.9% and 88.8% of the MPPT controlled system in a clear day and a cloudy day, respectively. It demonstrates the effectiveness of the hybrid control on limiting and smoothing the feed-in power and on improving the utilization factor of the PV inverter. It should be noted that further efforts could be devoted to improving the dynamics during the transitions from MPPT mode to CPG mode or vice versa.

In addition, Fig. 6(b) presents the thermal loading of a power switching device in the PV inverter under those two daily mission profiles. It demonstrates that the hybrid control concept can contribute to a redistribution of the thermal loading on the switching devices, affecting the overall reliability, which is highly dependent on the mean temperature and temperature variations [4]. As further explored in Fig. 7, the resultant yearly junction temperature profiles of the switching devices under the MPPT control and the hybrid MPPT-CPG control are compared. It can be noted that the peak junction temperature is reduced by $6 \text{ }^\circ\text{C}$ with the hybrid MPPT-CPG control scheme. Moreover, the temperature variations are also lowered in the hybrid control mode. The reduction of thermal stresses imply the reliability

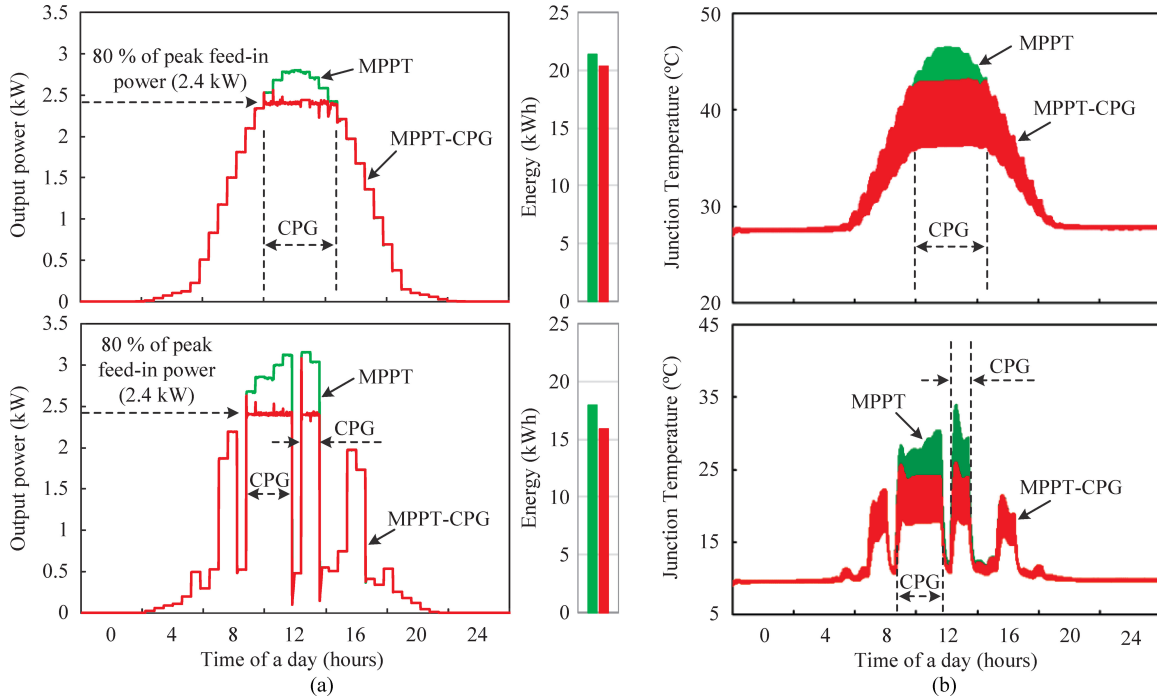

Fig. 6. Results of a single-phase PV system with and without the hybrid control using real-field daily profiles (top: A clear day; bottom: a cloudy day): (a) PV output power and energy yield and (b) thermal loading of an Insulated-Gate Bipolar Transistor (IGBT) of the PV inverter.

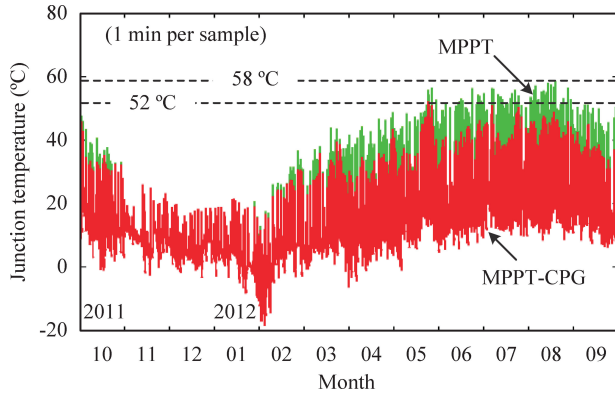

Fig. 7. Thermal loading of the power devices of the PV inverter with and without the proposed control concept (80 % of peak feed-in power) under a yearly real-field mission profile.

improvement and maintenance cost reduction, contributing to the reduction of cost-of-energy.

In order to further explore the potential reliability improvement by the proposed control concept, a lifetime model [10] (number of cycles to failure, N_f) is adopted as

$$N_f = A(\Delta T_j)^\alpha (ar)^{\beta_1 \Delta T_j + \beta_0} f(t_{ON}) \exp\left(\frac{E_a}{k_B T_{jm}}\right) f_d \quad (5)$$

with

$$f(t_{ON}) = \frac{C + (t_{ON})^\gamma}{C + 1}$$

where $A = 3.44 \times 10^{14}$, $\alpha = -4.92$, $\beta_0 = 1.94$, $\beta_1 = -9.01 \times 10^{-3}$, $\gamma = -1.21$, $f_d = 0.62$, and $C = 1.43$ are the

model parameters, ΔT_j , T_{jm} , and t_{ON} are the amplitude, mean value, and the period of the temperature cycles of the power devices, $E_a = 0.066$ eV is the activation energy, and $k_B = 8.617 \times 10^{-5}$ eV/K is the Boltzmann constant. A quantitative calculation of N_f can be enabled by a rain-flow counting algorithm [4], [14]. In this letter, for comparison, a normalized lifetime (LF) is defined as

$$LF = \frac{1}{\overline{LC}} \quad (6)$$

with \overline{LC} being the Life Consumption LC of the power devices in the MPPT-CPG operation mode normalized to that in MPPT mode. The LC can be calculated according to the Miner's rule [14] and the lifetime model shown in (5). The benefit of lifetime extension by the proposed control concept has been demonstrated in Fig. 8, where the energy yield and reliability improvement under different power limitations P_{limit} are presented. The power limit P_{limit} can be selected according to Fig. 8 when considering the energy yield and lifetime extension.

In addition, since the thermal loading of the power devices in the MPPT-CPG mode is reduced, the efficiency of the PV inverter might be improved. Fig. 9 shows the experimental results of the efficiency of a single-phase PV inverter and the case temperature of the power devices under different power levels. It can be observed in Fig. 9 that the efficiency of the PV inverter varies with the dc input power (i.e. the PV output power) and also the case temperature of the power devices. When the input power is kept constant (e.g., 2.4 kW of Point A and Point B), the case temperature is increased from 51 °C to 52 °C, while the efficiency is also increased from 93.20 % to 94.19 %. This can also contribute to an increase of the PV inverter utilization

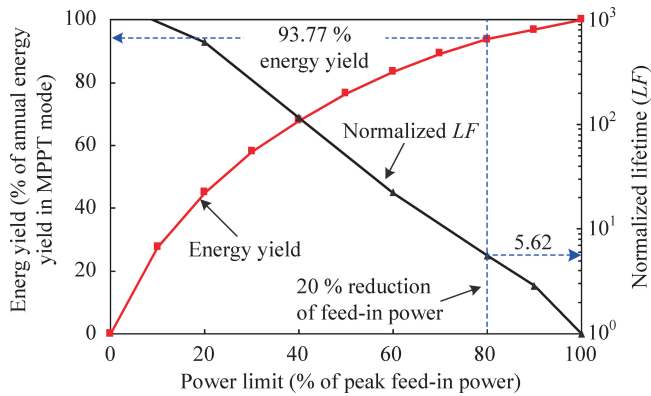

Fig. 8. Energy yield of the PV inverter and normalized lifetime of the power device in the PV inverter with the proposed control concept.

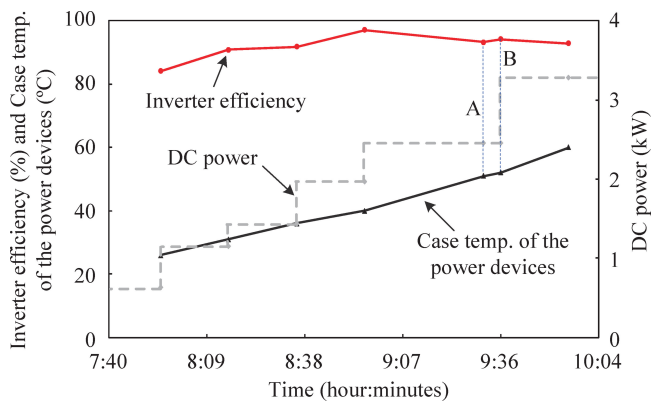

Fig. 9. Experimental results (inverter conversion efficiency and case temperature of the power devices) of a grid-connected single-phase PV inverter under different input power levels.

factor according to (4), and thus a reduction of the cost of energy can be achieved.

IV. CONCLUSION

A hybrid MPPT-CPG control concept is proposed for grid-connected PV inverters by considering the long-term mission profiles and the system level power management requirements. The proposed control strategy enables to increase the utilization factor of PV inverters and to reduce the temperature variations on power devices. Moreover, it is beneficial to system level power management by smoothing and limiting the PV inverter output power to some extent. This benefit is especially important to increase the PV installations with the existing grid infrastructure under a high PV penetration degree in the future. The

aforementioned advantages are compromised with the energy loss due to the proposed control, allowing the optimal selection of the power control limit depending on specific mission profiles. In the study case of a single-phase PV inverter, the power limit is selected as 80% of the maximum feed-in power of the PV panels, which is corresponding to a 6.23% energy yield reduction under a specific yearly mission profile. The PV inverter utilization is increased by 17% and the lifetime of the power devices is extended to 5.62 times of that in MPPT control mode.

REFERENCES

- [1] F. Blaabjerg, R. Teodorescu, M. Liserre, and A. V. Timbus, "Overview of control and grid synchronization for distributed power generation systems," *IEEE Trans. Ind. Electron.*, vol. 53, no. 5, pp. 1398–1409, Oct. 2006.
- [2] D. Maxwell. (2013, Nov. 13). Parts of northern Ireland's electricity grid overloaded. *BBC News*. [Online]. Available: <http://www.bbc.co.uk/>
- [3] A. Ahmed, L. Ran, S. Moon, and J.-H. Park, "A fast PV power tracking control algorithm with reduced power mode," *IEEE Trans. Energy Convers.*, vol. 28, no. 3, pp. 565–575, Sep. 2013.
- [4] H. Wang, M. Liserre, F. Blaabjerg, P. de Place Rikken, J.B. Jacobsen, T. Kvisgaard, and J. Landkildehus, "Transitioning to physics-of-failure as a reliability driver in power electronics," *IEEE J. Emerging Sel. Topics Power Electron.*, vol. 2, no. 1, pp. 97–114, Mar. 2014.
- [5] D. Rosenwirth and K. Strubbe. (2013, Mar.). Integrating variable renewables as Germany expands its grid. *RenewableEnergyWorld.com*. [Online]. Available: <http://renewableenergyworld.com/>
- [6] H. Gaztanaga, J. Landaluze, I. Etxeberria-Otadui, A. Padros, I. Berazaluze, and D. Cuesta, "Enhanced experimental PV plant grid-integration with a MW Lithium-Ion energy storage system," in *Proc. Energy Convers. Congr. Expo.*, 15–19, Sep. 2013, pp. 1324–1329.
- [7] Fraunhofer ISE. (2014, May 28). Recent facts about photovoltaics in Germany. Fraunhofer Inst. Sol. Energy Syst., Freiburg, Germany, Tech. Rep., [Online]. Available: <http://www.pv-fakten.de/>
- [8] R. Tonkoski, L. A. C. Lopes, and T. H. M. EL-Fouly, "Coordinated active power curtailment of grid connected PV inverters for overvoltage prevention," *IEEE Trans. Sustain. Energy*, vol. 2, no. 2, pp. 139–147, Apr. 2011.
- [9] Y. Ueda, K. Kurokawa, T. Tanabe, K. Kitamura, and H. Sugihara, "Analysis results of output power loss due to the grid voltage rise in grid-connected photovoltaic power generation systems," *IEEE Trans. Ind. Electron.*, vol. 55, no. 7, pp. 2744–2751, Jul. 2008.
- [10] U. Scheuermann, "Pragmatic bond wire model," Presentation at ECPE Workshop Lifetime Modeling Simulation, Jul. 3–4, 2013.
- [11] Y. Yang, H. Wang, and F. Blaabjerg, "Reduced junction temperature control during low-voltage ride-through for single-phase photovoltaic inverters," *IET Power Electron.*, pp. 1–10, in press, 2014. DOI: 10.1049/iet-pel.2013.0734.
- [12] D. Sera, L. Mathe, T. Kerekes, S. V. Spataru, and R. Teodorescu, "On the perturb-and-observe and incremental conductance MPPT methods for PV systems," *IEEE J. Photovoltaics*, vol. 3, no. 3, pp. 1070–1078, Jul. 2013.
- [13] L. Nousiainen, J. Puukko, A. Maki, T. Messo, J. Huusari, J. Jokipii, J. Viinamaki, D.T. Lobera, S. Valkealahti, and T. Suntio, "Photovoltaic generator as an input source for power electronic converters," *IEEE Trans. Power Electron.*, vol. 28, no. 6, pp. 3028–3038, Jun. 2013.
- [14] H. Huang and P. Mawby, "A lifetime estimation technique for voltage source inverters," *IEEE Trans. Power Electron.*, vol. 28, no. 8, pp. 4113–4119, Aug. 2013.