

Received 15 November 2022, accepted 16 December 2022, date of publication 22 December 2022, date of current version 29 December 2022.

Digital Object Identifier 10.1109/ACCESS.2022.3231603

TOPICAL REVIEW

The Recent Development of Optimal DOCR Protection Strategies for Sustainable Power Systems via Computational Intelligence Techniques

SUZANA PIL RAMLI¹, MEYSAM PASHAEI², MAZAHER KARIMI², (Senior Member, IEEE), KIMMO KAUHANIEMI², (Member, IEEE), ALIREZA POURDARYAEI^{3,4}, MEHDI DARYAEI^{3,4}, AND MASOUD ZAREI⁵

¹Department of Electrical Engineering, Faculty of Engineering, University of Malaya, Kuala Lumpur 50603, Malaysia

²School of Technology and Innovations, University of Vaasa, 65200 Vaasa, Finland

³Technical Planning and Load Forecasting Office, Hormozgan Regional Electric Company, Bandar Abbas 79167-95599, Iran

⁴Department of Power Engineering, Faculty of Electrical and Computer Engineering, Iran University of Science and Technology, Tehran 1684613114, Iran

⁵Substations and Relays Repairs and Maintenance Affairs, Operation and Protection Office, Hormozgan Regional Electric Company, Bandar Abbas 79167-95599, Iran

Corresponding author: Mazaher Karimi (mazaher.karimi@uvasa.fi)

This work was supported by the University of Vaasa through the Centralized Intelligent and Resilient Protection Schemes for Future Grids Applying 5G (CIRP-5G) Project with financial support provided by Business Finland under Grant 6937/31/2021.

ABSTRACT In the past decade, there has been unprecedented growth in distributed generation (DG) to cater to more load demand in the power grid. However, as the volume of these resources in the distribution network (DN) continues to increase, new challenges in voltage regulation, system stability, and protection coordination have emerged. The system is substantially changed when multiple types of DGs are incorporated into DN. These include new fault condition sources, different fault stages, a blinding influence on the protection scheme, a decrease in the relays' range, and a decline in the ability of existent relays to detect low-level fault currents. Due to the bidirectional current flow, this raises the fault current and, if improperly coordinated, causes the relays to trip unintentionally. Since fault current can flow in either direction (i.e. upstream or downstream), it is crucial that grid-mounted relays can detect it. This goal can be reached by including an optimal directional overcurrent relay (DOCR) coordination scheme in the system. In fact, DOCRs in interconnected power grids need to be coordinated effectively. This paper gives a comprehensive overview of the uses of various optimization strategies. The evaluation examines the benefits and drawbacks of the strategies used to address DOCR coordination problems. Additionally, this paper discusses future lines of inquiry for optimum DOCR coordination.

INDEX TERMS Computational intelligence, directional overcurrent relay, distributed generation, distribution network, renewable energy resources.

NOMENCLATURE

TMS_m Time multiplier setting.
 $ROT_{RCOT,k}$ Characteristic operational time DOCR.
 TMS_{min} Minimum range of time multiplier setting.

PSM_k Plug setting multiplier at relay k .
 TMS_{max} Maximum range of time setting multiplier corresponding to relay P .
 ROT_{mk} Primary relay operating time at fault m corresponding to relay k .
 PSC Plug setting current.
 CTR_m Turn ratio of current transformer.
 Y Set of relays.
 NPD Number of DOCR pair.

The associate editor coordinating the review of this manuscript and approving it for publication was Salvatore Favuzza^{id}.

$I_{f,m}^{min}$	Minimum fault current at the mid-point.
ROT_m	Operational time for DOCRs.
PSC_f	plug setting current corresponding to relay f .
ROT_{bk}	Backup relay operating time at fault b corresponding to relay k .
TCC	Time current characteristic.
$OLFC$	Overload factors current.
$I_{L,m}$	Maximum load current.
CTI_{min}	Minimum coordination time interval.
ROT_m	Relay operating time corresponding to relay m .
$RCOT_{kT}$	Relay characteristic operating time at fault k at bus T .
D_m	Fault occurrence probability measure.
NLP	Non-linear programming.
R_m	Primary/main DOCR relay.
$NIA-heuristic$	Nature Inspired Algorithm-heuristic.

I. INTRODUCTION

Consistent with a focus on sustainability and environmental concerns, distribution networks (DN) are currently being continually connected to distributed generation (DG) that utilized renewable energy sources. Common forms of renewable energy sources that are utilized as DG sources to create power include wind, photovoltaic, biomass, and mini-hydro. DG integration not only has environmental benefits but also increases the dependability of electrical supply and decreases power loss overall due to its proximity to loads. In spite of these advantages, integrating a large number of DG sources into DNs will result in the emergence of new challenges for the networks' protection mechanisms. Because of this, having an effective protection system is considered a crucial component of the power grid. A good protection system prevents power outages and keeps expensive equipment safe from being damaged, which means less money is lost. Coordination and isolation of the faulty zone by the protection relays are also essential for the security of the power system with enough margins with allowable time delays [1], [2], [3]. Therefore, the influence of DG on the DN needs to be carefully studied in order to provide an appropriate protection design, which will enable it to function efficiently [4], [5]. Prior to the existence of the DG, electricity is often distributed by a centralized source that supplies one end of a radial distribution network (DN) [6]. Thus, the fault current flows unidirectionally, which only needs a simpler protection design to isolate the faulted area.

Each line in a radial distribution network only needs one overcurrent relay (OCR) for individual line protection. As the grid-connected generator experiences a problem, the relay nearest to the fault location will detect the massive fault current [7]. However, a normal DN has significantly degraded in terms of network protection due to the widespread adoption of DG units [8], [9], [10], [11]. Due to the bidirectional current flow, the sensitivity and selectivity factor of each

relay has been compromised, resulting in unnecessary trip of the main and secondary protection schemes together with the coordination sequence of merging protection components such as breaker and fuse failed [12], [13]. Furthermore, it has been asserted that these issues with the protection of DN vary greatly depending on the scale of the network and the integrated DGs used. DG converts typical radial systems into grid networks since it is an active asset [14], [15]. However, when DGs are present in the system, it makes the DN to be multi-sourced, and thus there will be the possibility of having more than one fault current direction [16], [17]. This new network topology necessitates a revised protection strategy. In an integrated network, the DOCR has been chosen as the main protection relay that can locate faults in both directions. In general, DOCRs serves as a primary protection mechanism in sub-transmission or DN, while they are regarded as a secondary protection mechanism in transmission lines [18], [19].

The DOCRs coordination aims to achieve optimal settings for every protective relay. This helps to lessen the damage to the equipment and fix the problem as quickly as possible due to the improved tripping time provided by a proper coordination scheme [20], [21]. It is imperative to get familiar with each relay pair in the network to set the relays successfully. Generally, the plug setting current (PSC) in relays can range from 50% to 200% of rated current in 25% increments and is chosen based on the highest value for the load current and the minimum fault value. PSC is one of the primary variables in DOCRs that need to be precisely set in the coordination problem [3]. In normal practice, 50% to 200% refers to the overload factor of the load current that must be set to the PSC of DOCR, which must not be exceeded. For electromechanical relays, the percentage is in the step of 25%, while for numerical relays, it can be any value within that range. The engineer or the operator will set the plug current, based on the protected load type, to 100 to 125% or any other percentage of load current they desire.

The DOCR coordination problem is also known as a constraint-based problem. The number of constraints is directly proportional to the size of the network; hence, the sophistication of relay coordination will increase along with the size of the network. The major goal of the DOCR coordination problem is to minimize the overall operating time while achieving the TMS and PSC of each relay to prevent improper primary-backup (B-P) coordination DOCRs [22], [23]. In the late 1960s, researchers made significant efforts to deploy computational methods to resolve the DOCR coordination issue. The methods used by the researchers to coordinate the DOCR can be subdivided into five categories: traditional methods, Nature Inspired Algorithm (NIA)-heuristic methods, mathematical methods, hybrid-based strategies, and artificial intelligence models. Several methods that have been widely employed by researchers are depicted in Figure 1. Previously, trial and error, the curve-fitting methodology, and graph theory were the three methodologies that were utilized in conventional techniques. In the

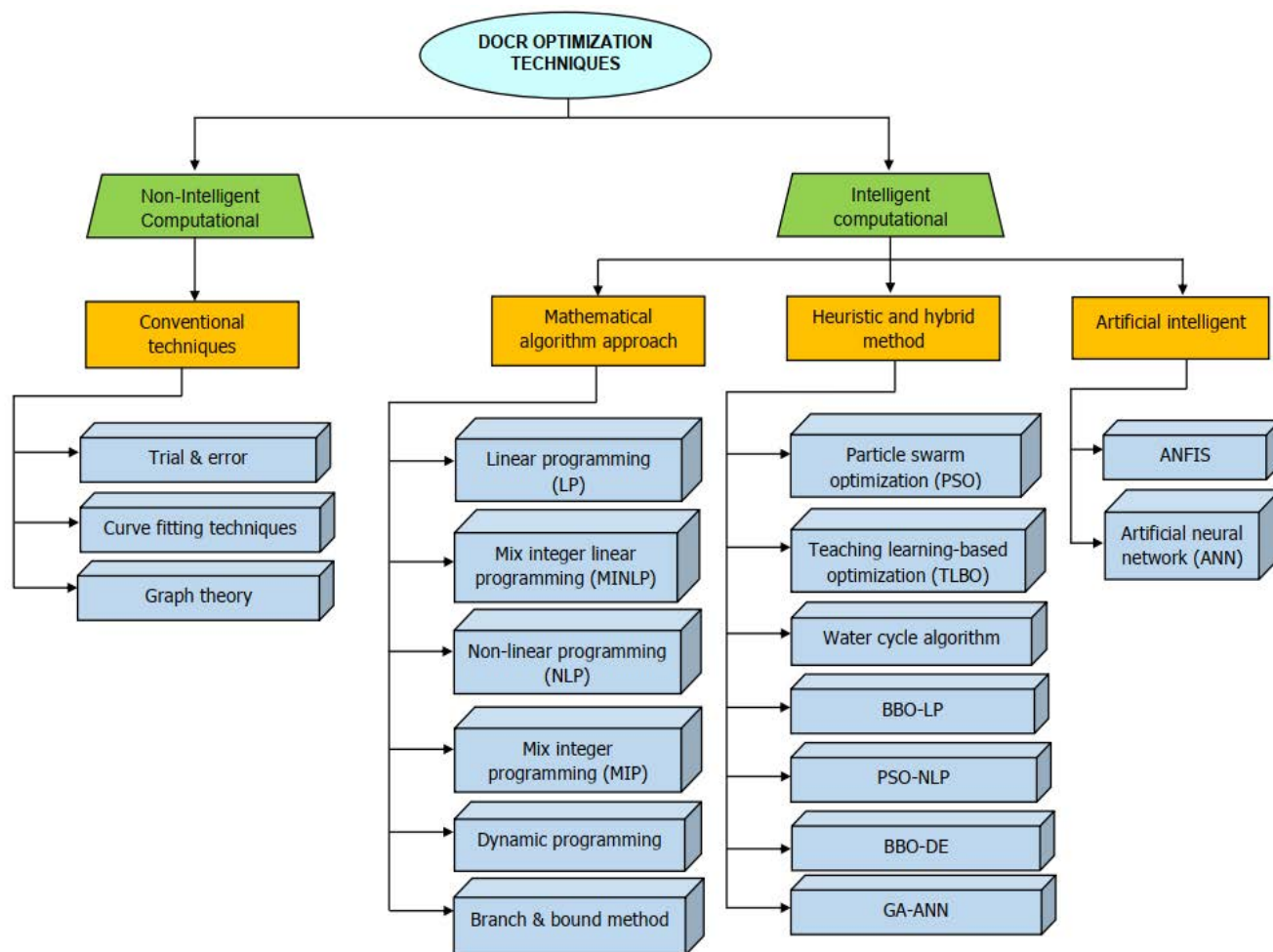

FIGURE 1. Coordinating the DOCR optimally using a variety of optimization methods.

past, the method of trial and error was carried out to determine the optimal setting for the relay. However, the technique may not provide sufficient relay settings for securing large-scale networks due to its poor convergence rate [3], [24], [25]. Nonetheless, the DOCR feature has been modelled mathematically through the use of the curve-fitting approach. As a result of these modelled time-inverse characteristics, the TMS and DOCR operation times are established. All of these techniques begin with a functional form that has a relay curve approximation, such as polynomials. The computer then calculates the functional coefficients that match the curves the best [18], [26]. In the graph theory method, breakpoint relays (BPS) are identified using a distribution network analysis, allowing for relay coordination establishment. The speed of convergence of the relay coordination problem relies on the suitable BPS being chosen [18], [27], [28]. The NIA-heuristic strategy is a repetitive generation method for finding the highest-quality results using learning procedures, incorporating many concepts to comb the search area. For issues with relay coordination, more intelligent methods have recently been used. Recently, the development of intelligent

methods of optimization has also adapted from surrounding fundamentals. These developments centered on studies of social animal behavior, natural phenomena including the flock of the bird, and the school of fish, the hydro-based cycle, the artistic composed music process, reminiscence of man patterns, Darwinian evolutionary notions, and swarm concept [29], [30]. At the same time, a mathematical optimization technique, such as linear programming (LP) and nonlinear programming (NLP) is used to solve the DOCR coordination problem. To accomplish selectivity between the relays, the TMS values are the only parameters taken into account in the LP method [31]. In contrast, the TMS and PSC relay settings are simultaneously tuned using the NLP method. Due to the fact that the issue formulation influences the outcomes of these methods, they guarantee the achievement of convergence and produce nearly optimal solutions. However, they are more computationally intensive [1], [32]. As a result, its difficulty level grows. [33], [34].

Researchers then have been investigating the solution for the coordination problem, combining metaheuristic methods with NLP or LP to overcome the shortcomings

of conventional protection methods. In [35], the DOCR problem is addressed using a Gravitational Search Algorithm and Sequential Quadratic Programming (GSA-SQP) hybrid. To obtain the optimum coordination of DOCRs, similar techniques such as Cuckoo Search (CS) with LP [36], Harmony search (HS) with non-linear programming(NLP) [37], and Salp-Swarm Algorithm (SSA) with Linear Programming (LP) (SSA-LP) [38] were used. Although numerous hybrid strategies have been put out to circumvent optimum DOCR coordination, further metaheuristic and mathematical programming pairings can still be extended, which might lead to more efficient and accurate solutions.

The contributions of this paper are summarized as follows:

- A comprehensive analysis of both the techniques' benefits and their limitations is performed. Based on the review, some upcoming work on achieving optimal DOCR is described.
- To determine the potential significance and superiority of NIA-heuristic, mathematical algorithms and AI/ANN techniques which might possess a wider search space to produce a group of populations in order to locate a feasible optimal solution
- To discover the effectiveness of combining metaheuristic techniques and mathematical programming in order to devise an efficient and precise coordination protection scheme.
- Article reviews a wide variety of methods in order to pinpoint the void in the most recent pertinent research. Most researchers are trying to attain a global optimization solution, by solving DOCR coordination challenges and minimizing the convergence interval.

The paper is structured in the following manner: Section 2 provides the formulation and constraint of the DOCR coordination problem. Section 3 examines the computational intelligence strategies proposed to alleviate relay coordination challenges, including their working principles, merits, and downsides. Section 4, provides suggestions for addressing the protection issues plaguing the integrated DN, and Section 5 has concluded the paper's findings.

II. COORDINATION PROBLEM FORMULATION AND CONSTRAINTS

In general, the coordination problem posed by DOCR is non-convex and highly constrained. The objective here is to pinpoint the optimum option for DOCR setup, which will reduce the amount of time that they spend performing operational tasks while still adhering to a variety of coordinated and borderline requirements [39], [40], [41], [42], [43]. The whole procedure for configuring relays and coordinating their operation within a power system network is depicted in Figure 2 [44]. The following is a comprehensive list of the procedures needed to explain process optimization in order to arrive at the best possible solution to the DOCR problem:

Step 1: The relay-equipped IEEE system is chosen. A load flow study and analysis of three-phase faults are performed

at this step, in order to establish the maximum value of load current and the magnitude of fault current, respectively.

Step 2: Relay settings are necessary and required. During this stage, the direction of the fault current is determined, the fault current value is gathered, the coordination scheme of each relay is defined, and decision variables and constraints for the formulation of the objective function (OF) are chosen.

Step 3: A technique for optimization is utilized. This step involves optimising the TMS, PSC, and relay operational time that is acquired for primary and backup protection using the most effective optimization approach.

Step 4: The relay setting is optimally affirmed. Here, industrial tool software is used to model the tested network's IEEE topology. Simulation data is computed. Mid-line fault current is applied to a simulated network. The software generates a time-current characteristic curve to determine each relay's tripping time.

A. FORMULATION OF OBJECTIVE FUNCTION

The sum operational time of the primary DOCR that secure the damaged network is the objective function (OF) whose minimization is required in the relay coordination problem, which is characterized by a nonlinear optimization function. The OF formulation can be represented as follows in Eq (1):

$$OF = \sum_{m=1}^a D_m ROT_m (main) \quad (1)$$

A DN-3 bus test system is presented in Figure 3. DOCR 1, 2, and 3 are indicated by R_1 , R_2 , and R_3 , accordingly. The fault locations in the system are indicated by the F_1 , F_2 , and F_3 . At the meantime for any occurrence of fault at F_3 , R_3 and R_2 will act as main and backup DOCR, MR and BR, respectively. At the same time, F_2 will be protected by R_2 as MR and R_1 as BR whenever a fault current flow through it. Lastly, for the fault at point F_1 , R_1 is the only available protection that will intervene as MR to protect the zone. The total main DOCR operating time (ROT) for this DN can be calculated as equation 1.

The protected area of each DOCR is indicated by the zone circled by dashed lines. Since MR and BR detect the fault concurrently, the lag between their operations must be equal to or longer than the coordination time interval (CTI) for the selectivity to be guaranteed. In this manner, the MR will have time to clear the fault, and the BP will only need to intervene if the MR is unable to do so [45].

B. DOCR CONSTRAINTS

Five constraints, which are outlined below, are typically met while keeping the concentration on minimising DOCR tripping time.

1) COORDINATION TIME INTERVAL

To guarantee the reliable operation of both the main and backup DOCRs, a pre-determined time interval must be established. In the event that the main DOCRs is unable

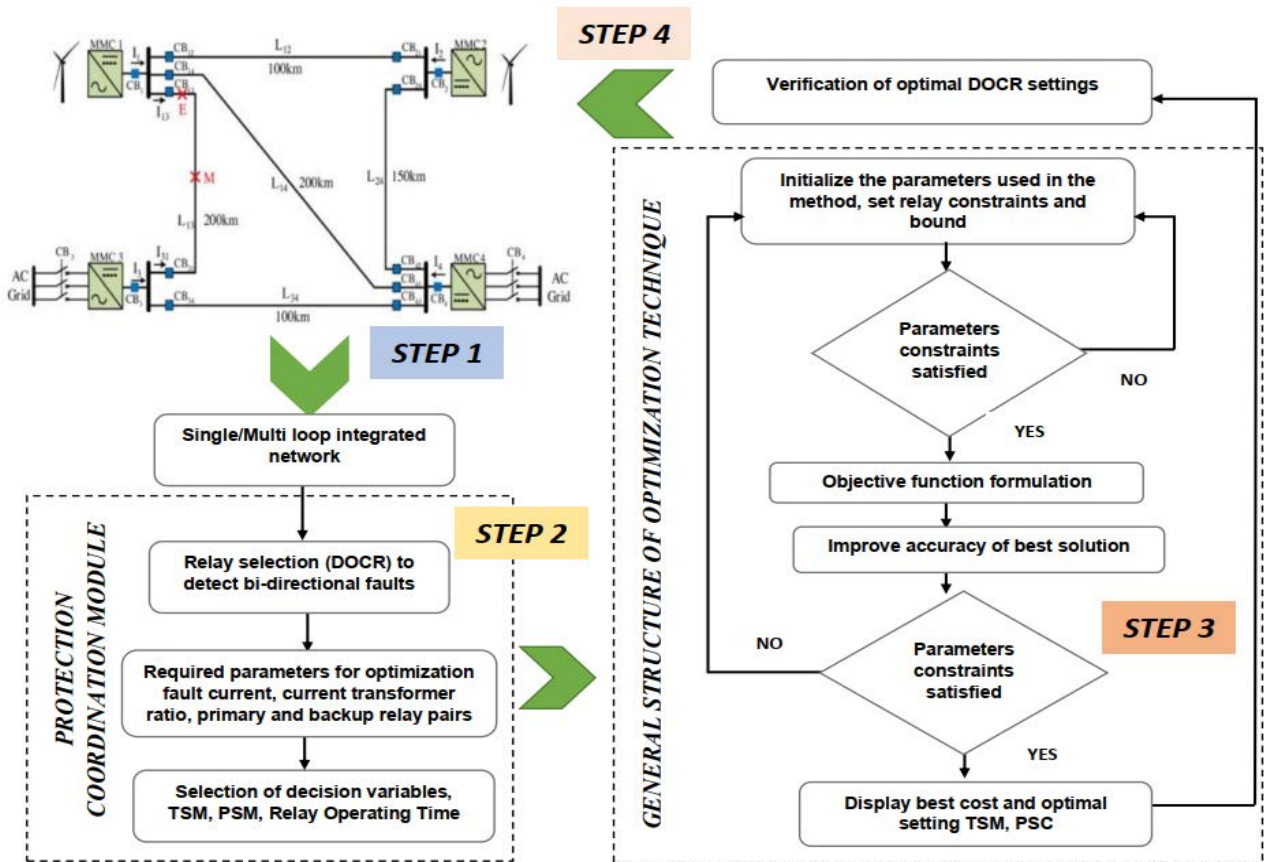

FIGURE 2. Procedure for the relay setting and coordination.

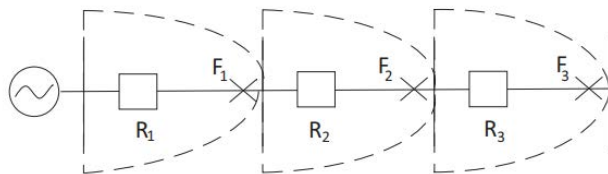

FIGURE 3. Radial DN comprises three DOCR with their respective main zones of protection.

to resolve the fault, the backup DOCRs would trip. Consequently, a period of time known as the coordination time interval (CTI) is required to ensure appropriate discrimination between DOCRs. In calculating the CTI, the DOCR type, time taken for the breaker to operate, the error of DOCR and the safety marginal are all taken into consideration. Reference [39], [41], [42], [46]. Following is the formulation for the duration coordination of the primary and backup DOCR:

$$ROT_{bk} - ROT_{mk} \geq CTI^{min} \quad \forall k \in NP D \quad (2)$$

2) TMS MARGIN

The TMS controls the operating time lag before the DOCR trips whenever the fault current reaches an amount that is equivalent to or exceeds the PSC [39], [41], [42], [46]. The

TMS's limits are as follows:

$$TMS_{min} \leq TMS_m \leq TMS_{max} \quad \forall m \in Y \quad (3)$$

3) PSC MARGIN

The PSC stipulates the ranges of secondary current based on two factors; DOCRs are restricted from operating at normal rated current and a minimum short circuit current. Additionally, the relays must react to the least fault current. The limits of the relay PSC can be specified as:

$$PSC_m^{min} \leq PSC_m \leq PSC_m^{max} \quad \forall m \in G \quad (4)$$

More details of the above expression are stated as follows:

$$PSC_m^{min} = \frac{OLF_x I_{L,m}}{CTR_m} \frac{I_{PSC}^{min}}{CTR_m} \quad (5)$$

$$PSC_m^{max} = \frac{2x I_{f,m}^{min}}{3x CTR_m} \frac{I_{PSC}^{max}}{CTR_m} \quad (6)$$

4) DOCR OPERATING TIME MARGIN

DOCR is calibrated to function within the specified time window, which means that it has an associated tripping time threshold and maximum operational time [40], [41], [42], [47], [48]. The explanation is expressed as follows:

$$ROT_m^{min} \leq ROT_m \leq ROT_m^{max} \quad \forall m \in G \quad (7)$$

5) DOCR OPERATING TIME CHARACTERISTICS

The non-linear formulation of the time inverse relay curve, which was addressed in [33] [39], [41], and [42] is represented by Eqs. (8), (9) and (10) in accordance with the IEC 60255-3 standard [49].

$$ROT_k = ROT_{RCOT,k} \times TMS_k \tag{8}$$

$$ROT_{RCOT,k} = \frac{c}{PSM_k^\beta - 1} \tag{9}$$

$$PSM_k = \frac{I_{f,k}}{PSC_k} \tag{10}$$

The expression in Eq. (8) and (9), are the coefficients of the time characteristic curve for any type of relay. The time characteristic curve for any type of relay has two coefficients which are denoted by the *c* and *β*.

III. DOCR OPTIMIZATION TECHNIQUES

Numerous computationally intelligent ways for DOCR coordination were published by researchers to address the issue discussed in Section 2 of this paper. In order to achieve the most optimal relay settings, all strategies generally attempt to minimise Eq. (1). There are two main categories of techniques. Conventional method protection is discussed in Section 3.1, with an evaluation of its benefits and drawbacks. The computationally intelligent ways are covered in Section 3.2, and that section comprises a total of four different methods.

A. CONVENTIONAL METHOD OF PROTECTION

Relay settings were manually changed by network operators prior to the widespread use of computers [30]. Regarding the load and impedance of the network, most DN operators previously adjusted the settings to permit the maximum rated current. In addition, they also computed the fault current and established the timespan that could be used to coordinate the DOCR by considering other parameters of relay (error and overshoot time) and the amount of time taken for the circuit breaker to trip. In order to retain the discrimination time, the current-time characteristics were displayed using log-log graph paper utilizing this data, adopting a tentative time multiplier setting. Nevertheless, this process is an exceedingly laborious task, and it involves a systematic review to determine whether or not the settings that are necessary for a little adjustment in the distribution network are still applicable [42]. This method was impractical and time-consuming in practice [50]. As a solution, several distinct computer methods have been offered which are known as trial-and-error, curve fitting and graph theory for solving the DOCR coordination problem. These methods range has been successfully used by most researchers. With the advent of the computer in the early 1960s, the appropriate setting for the relay was determined by the trial-and-error method. The approach was successful in resolving the coordination issue for an uncomplicated conventional network. Nevertheless, this approach had poor convergence

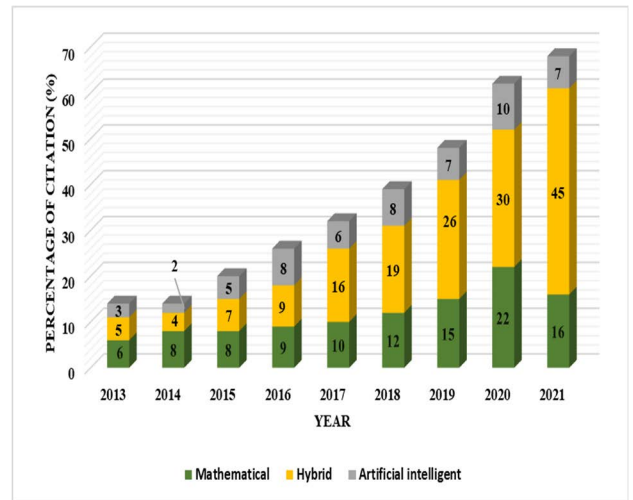

FIGURE 4. Percentage of citations in the optimal DOCR coordination study.

rates and necessitated a significant increase in the amount of computational work due to the growing scale and complexity of the network [51]. In the late 1980s, it became common practice to use a topological analysis-based, curve-fitting method that takes into account both graphical and functional dependencies. Curve fitting is easy for establishing OCRs settings. However, errors in the protection scheme may occur if the PSC is violated fewer than 1.3 times [18], [27], [28], [52].

Similar to that, a graph theoretical approach built on the breakpoint concept was employed [27], [53], [54]. The definition of all simple network loops has been broadened in [27] to include minimal BPS and every pair of B-P DOCR. This expands the scope of the linear graph theory definition. The functional dependence and methodical topological analytical approach formulate the constraints on these relay settings [54]. The method, however, is ineffective for networks with high DG penetration and complexity. Thereby, a computer-aided approach with a graphical user interface is used to pander to the difficulties that arise in coordinating DOCRs within a power network consisting of multiple DGs, but the strategy is not optimal enough when dealing with more miscoordination in the network [55], [56]. Compared to the curve-fitting and graph-theoretic approaches, optimization does not require the identification of breakpoints. Additionally, the value of TMS and PSC are not at the optimal point discovered by the graph and curve theoretical approaches [55], [56], [57]. Numerous studies have begun to investigate the use of artificial intelligence (AI) and nature-inspired algorithms (NIA) to resolve the best coordination of DOCR as a result of the issues [39], [47], [58], [59], [60].

B. COMPUTATIONAL INTELLIGENCE APPROACHES

The techniques can be divided into 2 primary groups, which are referred to as intelligent techniques and conventional

TABLE 1. Overview of a conventional technique to resolve the DOCR coordination problem.

Methodology	Defining characteristic	Advantage	Limitation
Trial & Error[30] [51]	The transparent plate has been trimmed to fit the current and time requirements of the relay.	Simple power network-friendly	Large networks are time-consuming. This method has a sluggish convergence rate and large relay TDS values.
Curve-fitting technique[18],[27], [28].	For many kinds of relay time operating curves, both linear and non-linear functions, time inverse operating characteristics are derived.	Easy for establishing relays	it's erroneous for currents less than 1.3 times the pickup current threshold
Graph theory [27], [102]	Relays for identifying breakpoints are performed.	all simple network loops have been broadened in to include both the minimal breakpoint set and all main- and backup-relay pairs	Networks with a significant penetration of DGs and complex topologies make the breakpoint selection process particularly crucial and inefficient.
Linear optimization technique[30], [47]	A linear programming problem is used as the basis for the formulation of the relay coordination problem.	TMS is LP-optimized for any fixed pickup current value.	The initial value of the pickup current, known as the PSC or plug setting current, can become mired in a local minimum if the designer or operator is inexperienced in tuning the value
Non-linear optimization technique[39], [55] [30]	The DOCR characteristic formulation is presented in non-linear programming form	Plug setting current, often known as PSC, is optimised in tandem with TMS.	Too intricate, with the potential for getting stuck in local minima if the PSC and TMS are set incorrectly.
AI/NIA [18], [103]	The two are commonly referred to as "optimization" and "analytical technique."	Easily achieves the global optimal solution, even for more complex networks with interdependencies	In the case of a stationary network topology

techniques. These optimization techniques of a certain DN are used in tandem with protection equipment to carry out the most effective protection scheme. Figure 4 depicts the percentage of researches citations for the DOCR coordinating area over the past seven years. It has been discovered that, in terms of percentage, hybrid approaches and mathematically based optimization show an upward tendency relative to artificial intelligence techniques. Nonetheless, hybrid techniques are preferred due to their robustness, quick convergence, and accelerated time to find a suitable solution to optimization issues. This will lead to effective DN protection via the most feasible relay settings [61]. The benefits and drawbacks of the optimization methods using combinatorial, LP/NLP, and ANFIS/ANN methods are tabulated in Table 1 and Table 2.

1) MATHEMATICAL TECHNIQUES

Based on mathematical formulations, numerical formulas are employed to develop mathematical approaches. Researchers have looked into new ways to configure the setting of the DOCR that use protective devices with well-designed objective functions. The rationale for using optimization techniques is to make sure that the DN with all of the

protection schemes dealing with DG is set up correctly and in a reliable manner [62], [63], [64].

Relay coordination has been conceptualised by some researchers as a nonlinear programming problem that can be resolved by using a variety of optimization strategies. Nevertheless, the techniques proposed are challenging and consume more time [56], [59]. The relay coordination problem was solved using the General Algebraic Modeling System (GAMS) software and was described in [39], [41], and [59] as a mixed-integer nonlinear programming (MINLP) problem. However, when the discrete PSC is taken into account, the coordination problem becomes more challenging due to the utilization of binary variables. [55]. Since coordinating the OCRs is a challenging task, simplex, dual simplex, and simplex two-phase methods of LP technique were frequently employed by some of the researchers [29], [39], [65], [66]. The methods depend on an initial forecast and are therefore liable to be mired in the local optimum point [67], [68]. For the TMS setting, these techniques set the PSC, and the operating time of each relay is presumed to be in a mathematical function of linear type. The big M-method, has been presumed in which the PSC is stipulated and resolved, was proposed in [69] for figuring out the best TMS value of overcurrent relays. After LP and Big-M procedures

TABLE 2. Overview of hybrid, analytical, and AI/ANN strategies for DOCR optimization problem.

Type of strategy	Name of technique	Suggested solution	Benefits	Drawback
Hybrid	WOA-SA [104]	DOCR coordination, the research has turned to convex optimization and problem relaxation techniques,	Help to keep the relay operation time for a complicated network to a minimum.	However, the method led to a lack of coordination in the system
	RGP-DE [105]	Using measured relay site voltages and currents,	To prove the effectiveness of the proposed method, the scheme was put to the test on a variety of DG sizes and positions.	But the procedure has not yet considered relay performance for high impedance faults and inverter-based DGs, which can significantly increase sensitivity problems for existing protection relay
	BBO-DE [106]	That uses both numerical and electromechanical	Enhance the performance of the standard BBO algorithm, which finds a satisfying solution with little iteration and processing power,	The rate at which the convergence process is slow, and as a result, algorithms grow more difficult to implement and more time-consuming to run.
Analytical	MINLP solver[107]	The strategy consisting of two stages of analysis	Eliminate the impossibility of solving the MINLP coordination problem and quickly reach the optimum result using iterative methods.	The outcome has not been validated.
	Analytic approach[108]	A numerical iterative solution is suggested for a new optimal relay setting methodology.	Short runtime, rapid convergence, and initial values independence and a lack of coordination order sensitivity	There is no context provided to demonstrate the method's efficacy.
	LP-interior point algorithm[24]	Utilised multiple centrality correctors in the primal-dual technique.	Management of reducing the dimension and number of constraints of the coordination problem	No analogous approach to compare it to in order to justify the effectiveness of the method.
AI/ANN	GA-ANN [109]	Using valid experimental results output from the MOF, which was capable of addressing the global optimum parameters settings identification as the data input to be trained by the ANN	Forecasting the precise optimum operating time for each protective DOCR of distinct bus lines by solving the characteristic curve of time-current	There was no real improvement in relay pair miscoordination eradication.
	Adaptive Neuro-Fuzzy Interface System (ANFIS)[110]	constructed protective relay model in the suggested system integrates the ANFIS structure, and each relay's ANFIS structure is optimally oriented to the topological state of the DG linked	For both post- and pre-contingency scenarios, the relay as a whole performs flawlessly. In any case, topological changes are few and far between, therefore network selection is less difficult	The method put only one type of inverse relay into consideration.

TABLE 2. (Continued.) Overview of hybrid, analytical, and AI/ANN strategies for DOCR optimization problem.

	ANN-FL [111]	an adaptive neuro-fuzzy interface system used for DG protection, are all covered by AI techniques	To locate the fault and trigger the related region breakers, the by recommending a unique method based on feed-forward neural networks	To collect the TMS settings for calculating the relay operating times, another study related to feed-forward multi-layer neural network technique for interlinked DNs and DGs must be considered.
--	--------------	---	--	---

were proposed, a comparison was made between them using LP-technique, Big-M-technique, and the dual-Simplex process in a preceding study [70].

In order to solve the relay coordination problem effectively, several techniques were already widely employed, including Linear Programming (LP), Non-linear Programming (NLP), Mixed-Integer Programming (MIP), Mixed-Integer Non-linear Programming (MINLP), and Branch and Bound. The major drawbacks of these approaches are their high dimensionality and also their low processing complexity [24], [71], [72]. For directional overcurrent relay coordination, the mixed integer programming problem (MIP) was established in the articles finding. By revamping the values of the global best (Gbest) and position vector (Pbest) with each iteration, the likelihood of becoming stuck in a local optimal solution is reduced [73]. The event tree approach is used to determine the probability of relay miscoordination, and this technique has been considered to perform the evaluation of on-line risk to pinpoint susceptibility areas [74]. M. Pourtandorost et al. in [75] utilized LP to optimise the TMS setting by predicting the PSC. D. Birla et al. used Sequential Quadratic Programming (SQP) in [1] to find an optimal solution to the coordination problem of a DOCR based solely on the location of the fault at the near end. However, to avoid a blinding trip, J. Gholinezhad et al. [76] have added the limitations of near-end selectivity and distant-end selectivity. To resolve this complicated problem, two phases were developed. In the first stage, an ordinary coordination technique is employed to identify sympathetic tripping. Meanwhile, in the second stage, additional constraints for addressing sympathy tripping derived from the first stage are implemented. This technique is able to prevent constraint breaches by loosening the constraints; but, due to the intricacy of the network, it consumes more time.

Methods based on mathematics are useful for analyzing more straightforward distribution networks. On the other hand, due to the high number of DOCRs in the interconnected networks, the coordination constraint matrix is complicated. This void prompted the researchers to investigate the adoption of NIA-heuristics and the combinatory of NIA-heuristics and mathematical methods to achieve a feasible result for the DCP, while mathematical methods tend to become trapped at local minimum points during the searching process.

2) NIA-HEURISTIC & HYBRID APPROACH

The most prominent usage of meta-heuristic methods for relay coordination is known as deterministic and multi-point search optimization, which has been employed to get an optimum global result in a faster manner [59].

For the DOCR coordination problem (DCP), the author proposes a method of optimization that takes into account FCL for the various operational modes of the DGs [77]. The GA is deploying the penalty factor in order to handle the complexity of the constraint in dealing with the DCP, which was in NLP formulation. To generate the optimum values required for PCP, the FCL constraints were considered together with the other protective parameters setting, TMS and PS. In addition, to locate the optimum and consistent feasible result for the DOCR parameters setting, the researcher recommended the well-known particle swarm optimization (PSO) technique to establish the analysis. In the meantime, a different approach that uses a modified PSO (MPSO) algorithm as an option to deal with relay coordination in a meshed network is reported in [78]. The comparison results of the modified PSO method with the results that were produced by the PSO algorithm is made, which had been employed purposely for the unconstrained DCP. A different MPSO-based strategy was employed to produce a more efficient approach for the interconnected DGs in large-scale networks. Results acquired from the analysis performed better than deterministic techniques for selecting the best PSC and TMS for DOCR, as well as improved selectivity and a reduction in relay operating time across various network layouts. To address the coordination issue with relays brought on by various DG penetration levels, fault types, and fault locations, many alternative metaheuristic solutions have been deployed in DN.

Hybrid optimization strategies have been put forth in [37], [40], and [79] to address this highly constrained DCP. By taking network instabilities and topological changes into account, the authors of [36] and [79] established an effective and thorough hybrid optimization framework for dynamic distribution networks to address the relay coordination problem. The convergence and efficiency of the NIA-heuristic technique have been improved by new and more thorough algorithms, such as the hybridization approach, which uses traditional and nature-inspired approaches [51]. In general, hybrid-type algorithms break the optimization problem down into smaller problems, with each smaller

problem being addressed using a different algorithm [80]. Mathematical optimization and NIA-heuristic optimization, or double NIA-heuristic optimization, are both components of these methods. In [38], the author suggests a fast hybrid optimization approach that incorporates the Salp-Swarm Algorithm and Linear Programming (SSA-LP). The PCP is tailored for relay coordination by incorporating both predefined and customizable features. Additionally, a mathematical formulation with constraints is developed for the grid-connected and islanded modes of service restoration at the radial DN with integrated DGs. The researcher is trying to reduce the complexity of the coordination constraint by optimizing the α and β constant of the DOCR equation. The researcher has included more decision variables which are by introducing the non-standard relay characteristics coefficients curve relay to provide more flexibility towards relay coordination problem. From here, it will reduce the convergence time and at the same time minimize the value of the OF and also correct the coordination issues between backup and primary.

The benefits of (GA) and nonlinear programming (NLP) are combined by the authors of [46] to determine the best OCR parameters setting. Nonlinearity has led to a new optimization problem formulation. The TMS and CSM values were initially determined using GA, and then the ultimate optimum values were determined using nonlinear programming (NLP) to overcome the pitfalls of both approaches. Using Laplace distribution, the author in [81] created Laplace Crossover PSO (LXPSO), an alternative method of optimization utilizing PSO. PDA, a partial differential algorithm, has been employed in [82] and produces results with higher accuracy than other traditional optimization techniques. During the implementation of GA, several types of relay characteristics and transformer curves were considered, and PDA chooses the closest point of the curves (VI or NI) for coordination constraints satisfactorily. Conversely, in [83], a hybrid CSA-FFA technique is established, with CSA serving as an upper limit in FFA to specify initial optimal values for TD and CSM, thereby guaranteeing a global optimal point. In comparison to the usual PSO and GA, the robustness and efficacy of this method have been well demonstrated [84]. The common challenges with relay coordination in large integrated networks can be alleviated by using NIA-heuristic or hybrid techniques in order to reach the optimal solution faster. Nevertheless, due to the inability to retain a large amount of load profile data, it only functions for fixed network topologies. The researchers were aware of this restriction, and as a result, they looked into the potential of using artificial intelligence as a solution to the problem.

3) ANN & AI

Artificial Intelligence (AI) emulates humanistic logical thought and duplicates it in a computer system that can reconfigure expert system networks [61]. In [85], S. Karupiah et al. recommended a new efficient relay operation time that can predict any chance of DOCR

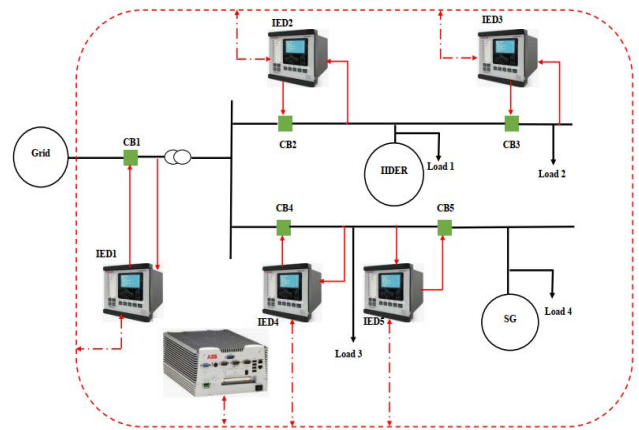

FIGURE 5. Adaptive relaying scheme.

miscoordination in the system using an Artificial Neural Network (ANN); nevertheless, the viability of this technique has not been verified through experimental testing. Similarly, in the GA solution, O. Emmanuel et al. deemed using valid experimental results output from the MOF, which was capable of addressing the global optimum parameters settings identification as to the input training data to the ANN by introducing a new GA-ANN hybrid method for solving the curve of Time-Current characteristics in predicting the exact optimum operation time for every DOCR at distinct bus lines [86]. However, there was no real improvement in relay pair miscoordination eradication. The fundamental problem with all of these proposed methods is that they require a large amount of memory to store and process the vast amounts of information needed to implement the various levels of protection. Considering the vastness of the set of additional conditions that must be taken into account, expanding the network or adding more DGs will need collecting an enormous amount of data. Additionally, the perception of the proposed framework becomes crucial if the current state of the DG is incompatible with any of the recorded DOCR settings. As a result, an adaptable technique is essential to search for a result to the problem associated with an existing approach. Matin Jamalian Daryani et al. suggested an Adaptive Neuro-Fuzzy Interface System (ANFIS), an adaptable method consisting of fuzzy logic (FL)-base and ANN, in [87]. The constructed protective relay model in the suggested system integrates the ANFIS structure, and each relay's ANFIS structure is optimally oriented to the topological state of the DG linked. For both post- and pre-contingency scenarios, the relay as a whole performs flawlessly. In any case, topological changes are few and far between, therefore network selection is less difficult. Nevertheless, the method put only one type of inverse relay into consideration. Figure 5 depicts the example of an adaptive relaying scheme [88].

Using AI approaches, this method anticipates the relay parameters to calculate the optimum DOCR settings based on network operating circumstances. ANN, FL control, and the

hybrid method (ANN-FL), a neuro-fuzzy interface adaptable system used for DG protection, are all covered by AI techniques [88], [89]. To locate the fault and trigger the related region breakers, the authors recommend a unique method based on a feed-forward neural networks [90]. Nonetheless, this method showed in the event that an un-operated circuit breaker in response to the triggering signal, there could be a backup region failure. To collect the TMS parameter for determining the DOCR time operation, another study correlated to feed-forward multi-layer neural network technique for interconnected DNs and DGs was undertaken. Furthermore, [85] postulated ANN technique to lessen miscoordination time occurrence during coordination. The data generated by the output of the ANN output demonstrates the reduction of miscoordination and an enhancement in operation times. To counteract the negative results of DOCR setting parameters on the basis of fault location, more enhancements are required. Because of the fluctuation in fault current rates, [91] released an online adaptive technique to deal with DCP. Based on network configuration, the method used adaptive FL to select the appropriate off-line settings. The findings demonstrate the efficacy of utilizing AI approaches. Yet, the optimization of DOCR settings has to be in an adaptive manner in accordance with the capacity of the DG and the sorts of faults.

Additionally, Daryani et al. in [87] introduced the Adaptive Neuro-Fuzzy Interface System (ANFIS), a dynamic method based on fuzzy logic and Artificial Neural Network (ANN). To proactively change the protection settings in accordance with the integrated state of the DG-grid, the suggested system incorporates the ANFIS structure into the designated protection relay scheme. Nevertheless, the proposed protection scheme may cause relay malfunction as a result of occurrences of changes in the network's topology and structure. The key challenge in the aforementioned systems is retaining the fault and relay data associated with protection settings with various sets in the memory of the computer. Additionally, the interpretation of the suggested structure becomes significant if the current circumstances of the linked DG-grid do not correspond to any of the recorded DOCR settings. Thus, finding a solution to the problem with current and future operational networks necessitates an adaptable strategy.

IV. RECOMMENDATIONS FOR FUTURE STUDIES

It is anticipated that the future abilities of smart grids would make use of network technology to bring about a revolution in the generation, transmission, distribution, and consumption of electricity [92]. The performance features of the power grid are getting more complicated as a result of factors such as the expansion of generator construction capacity, the proliferation of different forms of power, and the growing proximity of AC-DC hybrid connections to the power grid [93], [94].

Therefore, it is necessary to address the development of power grid-scale as well as the building of ultra-high voltage

(UHV) power grids, both of which lead to a fluctuation in fault current capacity as a result of the connection and disconnection of the utility grid [95], [96], [97]. According to the literature reviews in this study, alterations to power grids, such as increased penetration of distributed generation and dynamic load shifting, result in inconsistent coordination of the relay in order to resolve network problems [98]. Future recommendations are made in this section based on the gaps discovered in the literature, and DOCR for future studies are suggested. include:

- A promising approach to achieve significant operational time reduction is to eliminate or minimise the influence of handling constraints as much as feasible. Thus, a substantial reduction in TMS for relays is possible. However, any coordination constraint must not be breached. Using the approaches discussed in [99] and [100], the goal of this is to increase the size of the space containing feasible solutions that are technically possible while simultaneously reducing the size of the relay coordination problem. Nevertheless, the inequality coordination constraints, which are associated with various network topologies, should be satisfied by both methods.
- Establishing a set of criteria for selecting other than the standard IEC, IAC, IEEE, and US types relay decision variables or characteristics curves. Therefore, the usage of a user-defined relay characteristics curve is advised to improve the outcomes while tackling the relay coordination problem.
- Using a combination of an artificial neural network and fuzzy logic to coordinate numerical relays is a strategy for dealing with systems that are inadequate and unpredictable, especially the IBDG. In addition, it is expected that an accurate result will be produced by analyzing DOCRs using a particular neural network modelling. The majority of mathematically based models call for huge amounts of memory; therefore, another alternative is to include a proper microprocessor tools to retain the coordination programming by considering a few configurable options [101].
- Future research should focus on the following fundamental aspects of the hybrid intelligent computerised method. It is important to note that the impact of CTI toward tripping time of DOCR at their primary zone of protection makes it harder to coordinate protective relays as more Flexible AC Transmission Systems (FACTS) are added to the distribution network. Recently, a few techniques have been used to combat the effect of the controlled series FACTS device, specifically the TCSC and GCSC, on the optimal coordination of DOCRs problem. As a result, future research should consider using optimization techniques to achieve optimum DOCRs coordination settings for the transmission network with the integration of dynamic FACTS.
- With significant advancements, the use of variation coefficients or the combining of multiple phases of the

conventional procedure, various metaheuristic methods effectively address the challenges of protection schemes in contemporary power systems. Nevertheless, it is desirable to set a region for every coefficient in order to avoid risk in convergence occurring especially in complex power lines that are subject to substantial integration of distributed generation and active load redistribution.

- The field of power system resilience has acquired a lot of attention lately. In order to make the power system more resilient, it must be prepared for unforeseen high-intensity events that occur with a lower probability. It is clear that the usual N-1 and N-2 criteria for contingency planning are inadequate for the magnitude of fault seen throughout the incidents. So, research must be done to find the fault and notify the appropriate relays regarding their fault's path and the protection constraints. This will enhance the resilience of DG in any prolonged outage situation.

V. CONCLUSION

This paper emphasizes an up-to-date review of the most recent methods for achieving effective optimum protection of the DOCR coordination scheme. The complexity of the non-convex problem with the nonlinear highly-constrained problem and more objectives has been eased using a number of different established strategies. Innovative methods and technology, collectively referred to as computational intelligence, have nearly supplanted the conventional approaches that were used in an attempt to resolve protection challenges pertaining to the modern interconnected DN. A comprehensive analysis of hybrid methodologies, mathematical algorithms, and AI/ANN approaches is provided in this work. This analysis concludes that potential concerns such as the size of the DN, the complexity of coordination constraints, the type, and the size of the DG have contributed to the shortcomings of each method. Thus, ongoing research is still a crucial component in developing a reliable protection system to meet present and potential future issues in the linked DN. Additionally, it is advised for the sake of enhancing the smart grid security and dependability, recommendations should be made to strengthen the optimization strategies for coordination of DOCR.

ACKNOWLEDGMENT

The financial support provided through the research project is highly acknowledged.

REFERENCES

- [1] D. Birla, R. P. Maheshwari, and H. O. Gupta, "A new nonlinear directional overcurrent relay coordination technique, and banes and boons of near-end faults based approach," *IEEE Trans. Power Del.*, vol. 21, no. 3, pp. 1176–1182, Jul. 2006.
- [2] Y. G. Paithankar and S. Bhide, *Fundamentals of Power System Protection*. New Delhi, India: PHI Learning Pvt. Ltd., 2011.
- [3] R. Thangaraj, M. Pant, and K. Deep, "Optimal coordination of over-current relays using modified differential evolution algorithms," *Eng. Appl. Artif. Intell.*, vol. 23, no. 5, pp. 820–829, 2010.
- [4] L. Che, M. E. Khodayar, and M. Shahidehpour, "Adaptive protection system for microgrids: Protection practices of a functional microgrid system," *IEEE Electrific. Mag.*, vol. 2, no. 1, pp. 66–80, Mar. 2014.
- [5] A. Pathirana, A. Rajapakse, and N. Perera, "Development of a hybrid protection scheme for active distribution systems using polarities of current transients," *Electr. Power Syst. Res.*, vol. 152, pp. 377–389, Nov. 2017.
- [6] N. Huang, Q. He, J. Qi, Q. Hu, R. Wang, G. Cai, and D. Yang, "Multinodes interval electric vehicle day-ahead charging load forecasting based on joint adversarial generation," *Int. J. Electr. Power Energy Syst.*, vol. 143, Dec. 2022, Art. no. 108404.
- [7] X. Xu, D. Niu, B. Xiao, X. Guo, L. Zhang, and K. Wang, "Policy analysis for grid parity of wind power generation in China," *Energy Policy*, vol. 138, Mar. 2020, Art. no. 111225.
- [8] I. K. Tarsi, A. Sheikholeslami, T. Barforoushi, and S. M. B. Sadati, "Investigating impacts of distributed generation on distribution networks reliability: A mathematical model," in *Proc. Electr. Power Quality Supply Rel. Conf.*, Jun. 2010, pp. 117–124.
- [9] J. K. Taylor and A. H. Osman, "Restoration of fuse-recloser coordination in distribution system with high DG penetration," in *Proc. IEEE Power Energy Soc. Gen. Meeting-Convers. Del. Electr. Energy 21st Century*, Jul. 2008, pp. 1–8.
- [10] S. Chaitusaney and A. Yokoyama, "Prevention of reliability degradation from recloser–fuse miscoordination due to distributed generation," *IEEE Trans. Power Del.*, vol. 23, no. 4, pp. 2545–2554, Oct. 2008.
- [11] S. Chaitusaney and A. Yokoyama, "Reliability analysis of distribution system with distributed generation considering loss of protection coordination," in *Proc. Int. Conf. Probabilistic Methods Appl. Power Syst.*, Jun. 2006, pp. 1–8.
- [12] A. U. Khan, Q. Hong, A. Dysko, and C. Booth, "Review and evaluation of protection issues and solutions for future distribution networks," in *Proc. 54th Int. Universities Power Eng. Conf. (UPEC)*, Sep. 2019, pp. 1–6.
- [13] S. P. Ramli, H. Mokhlis, W. R. Wong, M. A. Muhammad, N. N. Mansor, and M. H. Hussain, "Optimal coordination of directional overcurrent relay based on combination of improved particle swarm optimization and linear programming considering multiple characteristics curve," *TURKISH J. Electr. Eng. Comput. Sci.*, vol. 2021, pp. 1765–1780, May 2021.
- [14] S.-E. Razavi, E. Rahimi, M. S. Javadi, A. E. Nezhad, M. Lotfi, M. Shafie-Khah, and J. P. S. Catalzo, "Impact of distributed generation on protection and voltage regulation of distribution systems: A review," *Renew. Sustain. Energy Rev.*, vol. 105, pp. 157–167, May 2019.
- [15] L. Zhang, D. Liu, G. Cai, L. Lyu, L. H. Koh, and T. Wang, "An optimal dispatch model for virtual power plant that incorporates carbon trading and green certificate trading," *Int. J. Electr. Power Energy Syst.*, vol. 144, Jan. 2023, Art. no. 108558.
- [16] T. Ni, D. Liu, Q. Xu, Z. Huang, H. Liang, and A. Yan, "Architecture of cobweb-based redundant TSV for clustered faults," *IEEE Trans. Very Large Scale Integr. (VLSI) Syst.*, vol. 28, no. 7, pp. 1736–1739, Jul. 2020.
- [17] X. Xu, D. Niu, L. Peng, S. Zheng, and J. Qiu, "Hierarchical multi-objective optimal planning model of active distribution network considering distributed generation and demand-side response," *Sustain. Energy Technol. Assessments*, vol. 53, Oct. 2022, Art. no. 102438.
- [18] M. Singh, "Protection coordination in distribution systems with and without distributed energy resources—A review," *Protection Control Mod. Power Syst.*, vol. 2, no. 1, p. 27, Dec. 2017.
- [19] L. Guo, C. Ye, Y. Ding, and P. Wang, "Allocation of centrally switched fault current limiters enabled by 5G in transmission system," *IEEE Trans. Power Del.*, vol. 36, no. 5, pp. 3231–3241, Oct. 2021.
- [20] J. M. Tripathi and S. K. Mallik, "An adaptive protection coordination strategy utilizing user-defined characteristics of DOCRs in a microgrid," *Electr. Power Syst. Res.*, vol. 214, Jan. 2023, Art. no. 108900.
- [21] F. Wadie, E. Abdulgawad, and A. M. Abd-Allah, "Adaptive real-time protection scheme for distribution networks with high penetration levels of renewable energy resources," *Ain Shams Eng. J.*, vol. 2021, Oct. 2022, Art. no. 102005.
- [22] A. Y. Abdelaziz, H. Talaat, A. Nousseir, and A. A. Hajjar, "An adaptive protection scheme for optimal coordination of overcurrent relays," *Electr. Power Syst. Res.*, vol. 61, no. 1, pp. 1–9, 2002.
- [23] M. Hussain, I. Musirin, S. Rahim, and A. Abidin, "Computational intelligence based technique in optimal overcurrent relay coordination: A review," *Electron. Eng.*, vol. 2, no. 1, pp. 1–9, 2013.

- [24] A. J. Urdaneta, L. G. Pérez, J. F. Gómez, B. Feijoo, and M. González, "Presolve analysis and interior point solutions of the linear programming coordination problem of directional overcurrent relays," *Int. J. Electr. Power Energy Syst.*, vol. 23, no. 8, pp. 819–825, Nov. 2001.
- [25] A. J. Urdaneta, H. Restrepo, S. Marquez, and J. Sanchez, "Coordination of directional overcurrent relay timing using linear programming," *IEEE Trans. Power Del.*, vol. 11, no. 1, pp. 122–129, Jan. 1996.
- [26] S. Zocholl, J. Akamine, A. Hughes, M. Sachdev, and L. Scharf, "Computer representation of overcurrent relay characteristics: IEEE committee report," *IEEE Trans. Power Del.*, vol. 4, no. 3, pp. 1659–1667, Oct. 1989.
- [27] M. Damborg, R. Ramaswami, S. Venkata, and J. Postforoosh, "Computer aided transmission protection system design Part I: Algorithms," *IEEE Trans. Power App. Syst.*, vol. PAS-103, no. 1, pp. 51–59, Jan. 1984.
- [28] K. R. Shah, E. D. Detjen, and A. G. Phadke, "Feasibility of adaptive distribution protection system using computer overcurrent relaying concept," *IEEE Trans. Ind. Appl.*, vol. IA-24, no. 5, pp. 792–797, Sep. 1988.
- [29] V. Rashtchi, J. Gholinezhad, and P. Farhang, "Optimal coordination of overcurrent relays using honey bee algorithm," in *Proc. Int. Congr. Ultra Mod. Telecommun. Control Syst.*, Oct. 2010, pp. 401–405.
- [30] A. Korashy, S. Kamel, A.-R. Youssef, and F. Jurado, "Modified water cycle algorithm for optimal direction overcurrent relays coordination," *Appl. Soft Comput.*, vol. 74, pp. 10–25, Jan. 2019.
- [31] Y. Xiao, Y. Zhang, I. Kaku, R. Kang, and X. Pan, "Electric vehicle routing problem: A systematic review and a new comprehensive model with nonlinear energy recharging and consumption," *Renew. Sustain. Energy Rev.*, vol. 151, Nov. 2021, Art. no. 111567.
- [32] S. S. Gokhale and V. S. Kale, "Application of the firefly algorithm to optimal over-current relay coordination," in *Proc. Int. Conf. Optim. Electr. Electron. Equip. (OPTIM)*, May 2014, pp. 150–154.
- [33] T. Amraee, "Coordination of directional overcurrent relays using seeker algorithm," *IEEE Trans. Power Del.*, vol. 27, no. 3, pp. 1415–1422, Jul. 2012.
- [34] V. A. Papaspiliotopoulos, T. Kurashvili, and G. N. Korres, "Optimal coordination of directional overcurrent relays in distribution systems with distributed generation based on a hybrid PSO-LP algorithm," *Comput. Sci., Eng., Tech. Rep.*, 2014.
- [35] J. Radosavljević and M. Jevtić, "Hybrid GSA-SQP algorithm for optimal coordination of directional overcurrent relays," *IET Gener. Transmiss. Distrib.*, vol. 10, no. 8, pp. 1928–1937, Feb. 2016.
- [36] M. Shabani and A. Karimi, "A robust approach for coordination of directional overcurrent relays in active radial and meshed distribution networks considering uncertainties," *Int. Trans. Electr. Energy Syst.*, vol. 28, no. 5, p. e2532, May 2018.
- [37] V. N. Rajput and K. S. Pandya, "A hybrid improved harmony search algorithm-nonlinear programming approach for optimal coordination of directional overcurrent relays including characteristic selection," *Int. J. Power Energy Convers.*, vol. 9, no. 3, pp. 228–253, 2018.
- [38] M. Usama, M. Moghavvemi, H. Mokhlis, N. N. Mansor, H. Farooq, and A. Pourdaryaei, "Optimal protection coordination scheme for radial distribution network considering ON/OFF-grid," *IEEE Access*, vol. 9, pp. 34921–34937, 2021.
- [39] A. S. Noghabi, J. Sadeh, and H. R. Mashhadi, "Considering different network topologies in optimal overcurrent relay coordination using a hybrid GA," *IEEE Trans. Power Del.*, vol. 24, no. 4, pp. 1857–1863, Oct. 2009.
- [40] F. A. Albasri, A. R. Alroomi, and J. H. Talaq, "Optimal coordination of directional overcurrent relays using biogeography-based optimization algorithms," *IEEE Trans. Power Del.*, vol. 30, no. 4, pp. 1810–1820, Aug. 2015.
- [41] P. P. Bedekar and S. R. Bhide, "Optimum coordination of directional overcurrent relays using the hybrid GA-NLP approach," *IEEE Trans. Power Del.*, vol. 26, no. 1, pp. 109–119, Jan. 2011.
- [42] V. N. Rajput and K. S. Pandya, "Coordination of directional overcurrent relays in the interconnected power systems using effective tuning of harmony search algorithm," *Sustain. Comput., Informat. Syst.*, vol. 15, pp. 1–15, Sep. 2017.
- [43] Y. Damchi, M. Dolatabadi, H. R. Mashhadi, and J. Sadeh, "MILP approach for optimal coordination of directional overcurrent relays in interconnected power systems," *Electr. Power Syst. Res.*, vol. 158, pp. 267–274, Feb. 2018.
- [44] S. P. Ramli, M. Usama, H. Mokhlis, W. R. Wong, M. H. Hussain, M. A. Muhammad, and N. N. Manso, "Optimal directional overcurrent relay coordination based on computational intelligence technique: A review," *Turkish J. Electr. Eng. Comput. Sci.*, vol. 29, no. 3, pp. 1284–1307, 2021.
- [45] A. A. Kida and L. A. Gallego, "A high-performance hybrid algorithm to solve the optimal coordination of overcurrent relays in radial distribution networks considering several curve shapes," *Elect. Power Syst. Res.*, vol. 140, pp. 464–472, Nov. 2016.
- [46] M. M. Mansour, S. F. Mekhamer, and N. E.-S. El-Kharbawe, "A modified particle swarm optimizer for the coordination of directional overcurrent relays," *IEEE Trans. Power Del.*, vol. 22, no. 3, pp. 1400–1410, Jul. 2007.
- [47] A. J. Urdaneta, R. Nadira, and L. G. Perez Jimenez, "Optimal coordination of directional overcurrent relays in interconnected power systems," *IEEE Trans. Power Del.*, vol. PD-3, no. 3, pp. 903–911, Jul. 1988.
- [48] P. Yadav, R. Kumar, S. K. Panda, and C. S. Chang, "An intelligent tuned harmony search algorithm for optimisation," *Inf. Sci.*, vol. 196, pp. 47–72, Aug. 2012.
- [49] Z. Moravej, F. Adelnia, and F. Abbasi, "Optimal coordination of directional overcurrent relays using NSGA-II," *Electr. Power Syst. Res.*, vol. 119, pp. 228–236, Feb. 2015.
- [50] A. S. Pabla, *Electric Power Distribution*. New York, NY, USA: McGraw-Hill, 2012.
- [51] M. Singh, B. K. Panigrahi, and A. R. Abhyankar, "Optimal coordination of directional over-current relays using teaching learning-based optimization (TLBO) algorithm," *Int. J. Electr. Power Energy Syst.*, vol. 50, pp. 33–41, Sep. 2013.
- [52] S. P. Ramli, H. Mokhlis, W. R. Wong, M. A. Muhammad, and N. N. Mansor, "Optimal coordination of directional overcurrent relay based on combination of firefly algorithm and linear programming," *Ain Shams Eng. J.*, vol. 13, no. 6, Nov. 2022, Art. no. 101777.
- [53] M. Dwarakanath and L. Nowitz, "An application of linear graph theory for coordination of directional overcurrent relays," in *Electric Power Problems: The Mathematical Challenge*. Philadelphia, PA, USA: SIAM, 1980, pp. 104–114.
- [54] L. Jenkins, H. P. Khincha, S. Shivakumar, and P. K. Dash, "An application of functional dependencies to the topological analysis of protection schemes," *IEEE Trans. Power Del.*, vol. 7, no. 1, pp. 77–83, Jan. 1992.
- [55] D. Birla, R. P. Maheshwari, and H. O. Gupta, "Time-overcurrent relay coordination: A review," *Int. J. Emerg. Electr. Power Syst.*, vol. 2, no. 2, pp. 1–15, Apr. 2005.
- [56] M. H. Hussain, S. R. A. Rahim, and I. Musirin, "Optimal overcurrent relay coordination: A review," *Proc. Eng.*, vol. 53, no. 1, pp. 332–336, 2013.
- [57] M. Hussain, I. Musirin, A. Abidin, and S. A. J. V. Rahim, "Solving directional overcurrent relay coordination problem using artificial bees colony," *Int. J. Electr. Comput. Eng.*, vol. 8, pp. 766–771, Apr. 2014.
- [58] M. Ezzeddine and R. Kaczmarek, "A novel method for optimal coordination of directional overcurrent relays considering their available discrete settings and several operation characteristics," *Electr. Power Syst. Res.*, vol. 81, no. 7, pp. 1475–1481, Jul. 2011.
- [59] H. A. Abyaneh, M. Al-Dabbagh, H. K. Karegar, S. H. H. Sadeghi, and R. A. J. Khan, "A new optimal approach for coordination of overcurrent relays in interconnected power systems," *IEEE Trans. Power Del.*, vol. 18, no. 2, pp. 430–435, Apr. 2003.
- [60] M. Ezzeddine, R. Kaczmarek, and M. U. Iftikhar, "Coordination of directional overcurrent relays using a novel method to select their settings," *IET Gener. Transmiss. Distrib.*, vol. 5, no. 7, pp. 743–750, Jul. 2007.
- [61] M. Norshahrani, H. Mokhlis, H. A. Bakar, J. J. Jamian, and S. Sukumar, "Progress on protection strategies to mitigate the impact of renewable distributed generation on distribution systems," *Energies*, vol. 10, no. 11, p. 1864, 2017.
- [62] J. Ehrenberger and J. Svec, "Protection settings optimization in distributed generation system," in *Proc. IEEE Int. Energy Conf.*, Apr. 2016, pp. 1–6.
- [63] H. R. E. H. Boucekara, M. Zellagui, and M. A. Abido, "Optimal coordination of directional overcurrent relays using a modified electromagnetic field optimization algorithm," *Appl. Soft Comput.*, vol. 54, pp. 267–283, May 2017.

- [64] H. M. Sharaf, H. H. Zeineldin, D. K. Ibrahim, and E. E.-D. A. El-Zahaba, "A proposed coordination strategy for meshed distribution systems with DG considering user-defined characteristics of directional inverse time overcurrent relays," *Int. J. Elect. Power Energy Syst.*, vol. 65, pp. 49–58, Feb. 2015.
- [65] F. Razavi, H. A. Abyaneh, M. Al-Dabbagh, R. Mohammadi, and H. Torkaman, "A new comprehensive genetic algorithm method for optimal overcurrent relays coordination," *Electr. Power Syst. Res.*, vol. 78, pp. 713–720, Apr. 2008.
- [66] M. Singh, B. K. Panigrahi, and A. R. Abhyankar, "Optimal overcurrent relay coordination in distribution system," in *Proc. Int. Conf. Energy, Autom. Signal*, Dec. 2011, pp. 1–6.
- [67] Z. Moravej, M. Jazaeri, and M. Gholamzadeh, "Optimal coordination of distance and over-current relays in series compensated systems based on MAPSO," *Energy Convers. Manage.*, vol. 56, pp. 140–151, Apr. 2012.
- [68] T. Cai, D. Yu, H. Liu, and F. Gao, "Computational analysis of variational inequalities using mean extra-gradient approach," *Mathematics*, vol. 10, no. 13, p. 2318, Jul. 2022.
- [69] P. P. Bedekar, S. R. Bhide, and V. S. Kale, "Optimum time coordination of overcurrent relays in distribution system using big-M (penalty) method," *WSEAS Trans. Power Syst.*, vol. 4, no. 11, pp. 341–350, 2009.
- [70] P. P. Bedekar, S. R. Bhide, and V. S. Kale, "Determining optimum TMS and PS of overcurrent relays using linear programming technique," in *Proc. 8th Electr. Eng./Electron., Comput., Telecommun. Inf. Technol. (ECTI) Assoc. Thailand-Conf.*, May 2011, pp. 700–703.
- [71] A. S. Noghbi, H. R. Mashhadi, and J. Sadeh, "Optimal coordination of directional overcurrent relays considering different network topologies using interval linear programming," *IEEE Trans. Power Del.*, vol. 25, no. 3, pp. 1348–1354, Jul. 2010.
- [72] C. W. So and K. K. Li, "Time coordination method for power system protection by evolutionary algorithm," *IEEE Trans. Ind. Appl.*, vol. 36, no. 5, pp. 1235–1240, Sep. 2000.
- [73] J. Gholinezhad, K. Mazlumi, and P. Farhang, "Overcurrent relay coordination using MINLP technique," in *Proc. 19th Iranian Conf. Electr. Eng.*, May 2011, pp. 1–6.
- [74] B. Zhang, Y. Lv, and W. Wu, "Hidden failure risk assessment and on-line adaptive relay coordination based on risk minimization," *Tech. Rep.*, Jan. 2008.
- [75] S. Jamali and M. Pourtandorost, "New approach to coordination of distance relay zone-2 with overcurrent protection using linear programming methods," in *Proc. 39th Int. Universities Power Eng. Conf.*, vol. 2, 2004, pp. 827–831.
- [76] D. Birla, R. P. Maheshwari, and H. O. Gupta, "An approach to tackle the threat of sympathy trips in directional overcurrent relay coordination," *IEEE Trans. Power Del.*, vol. 22, no. 1, pp. 851–858, Apr. 2007.
- [77] W. K. A. Najy, H. H. Zeineldin, and W. L. Woon, "Optimal protection coordination for microgrids with grid-connected and islanded capability," *IEEE Trans. Ind. Electron.*, vol. 60, no. 4, pp. 1668–1677, Apr. 2013.
- [78] H. H. Zeineldin, E. F. El-Saadany, and M. M. A. Salama, "Optimal coordination of overcurrent relays using a modified particle swarm optimization," *Electr. Power Syst. Res.*, vol. 76, no. 11, pp. 988–995, 2006.
- [79] K. A. Saleh, H. H. Zeineldin, and E. F. El-Saadany, "Optimal protection coordination for microgrids considering N–1 contingency," *IEEE Trans. Ind. Informat.*, vol. 13, no. 5, pp. 2270–2278, Oct. 2017.
- [80] A. A. Kida, A. E. Labrador Rivas, and L. A. Gallego, "An improved simulated annealing–linear programming hybrid algorithm applied to the optimal coordination of directional overcurrent relays," *Electr. Power Syst. Res.*, vol. 181, Apr. 2020, Art. no. 106197.
- [81] J. Kennedy, P. Ciuffo, and A. Agalgaonkar, "A review of protection systems for distribution networks embedded with renewable generation," *Renew. Sustain. Energy Rev.*, vol. 58, pp. 1308–1317, May 2016.
- [82] I. Chilvers, N. Jenkins, and P. Crossley, "Distance relaying of 11 kV circuits to increase the installed capacity of distributed generation," *IEE Proc. Gener., Transmiss. Distrib.*, vol. 152, no. 1, pp. 40–46, Jan. 2005.
- [83] I. Almutairy, "A review of coordination strategies and techniques for overcoming challenges to microgrid protection," in *Proc. Saudi Arabia Smart Grid (SASG)*, 2016, pp. 1–4.
- [84] M. R. Miveh, M. Gandomkar, S. Mirsaedi, and H. Nasiban, "Micro-grid protection by designing a communication-assisted digital relay," *Amer. J. Sci. Res.*, vol. 51, pp. 62–68, Feb. 2012.
- [85] S. Karupiah, M. Hussain, I. Musirin, and S. Rahim, "Prediction of overcurrent relay miscoordination time using artificial neural network," *Indonesian J. Electr. Eng. Comput. Sci.*, vol. 14, no. 1, pp. 319–326, 2019.
- [86] O. Emmanuel, M. L. Othman, H. Hizam, N. Rezaei, and M. M. Othman, "Time-current characteristic curve prediction for directional overcurrent relays in interconnected network using artificial neural network," *ARNP J. Eng. Appl. Sci.*, vol. 10, no. 1, pp. 10679–10685, 2015.
- [87] M. J. Daryani, A. E. Karkevandi, and O. Usta, "A hybrid approach for microgrid protection system based on neural network and fuzzy logic," in *Proc. IEEE PES Innov. Smart Grid Technol. Eur. (ISGT-Europe)*, Sep. 2019, pp. 1–5.
- [88] N. Hussain, M. Nasir, J. C. Vasquez, and J. M. Guerrero, "Recent developments and challenges on AC microgrids fault detection and protection systems—A review," *Energies*, vol. 13, no. 9, p. 2149, May 2020.
- [89] P. H. A. Barra, D. V. Coury, and R. A. S. Fernandes, "A survey on adaptive protection of microgrids and distribution systems with distributed generators," *Renew. Sustain. Energy Rev.*, vol. 118, Feb. 2020, Art. no. 109524.
- [90] N. Rezaei and M.-R. Haghifam, "Protection scheme for a distribution system with distributed generation using neural networks," *Int. J. Electr. Power Energy Syst.*, vol. 30, no. 4, pp. 235–241, May 2008.
- [91] N. El Naily, S. M. Saad, T. Hussein, and F. A. Mohamed, "Minimizing the impact of distributed generation of a weak distribution network with an artificial intelligence technique," *Appl. Sol. Energy*, vol. 53, no. 2, pp. 109–122, Apr. 2017.
- [92] J. Li, Y. Deng, W. Sun, W. Li, R. Li, Q. Li, and Z. Liu, "Resource orchestration of cloud-edge-based smart grid fault detection," *ACM Trans. Sensor Netw.*, vol. 18, no. 3, pp. 1–26, Aug. 2022.
- [93] L. Fucui, C. Tao, G. Qiuting, Q. Yuchen, and H. Wei, "Design and implementation of intelligent dispatching operation strategy platform for power grid with UHV," in *Proc. IEEE Innov. Smart Grid Technol.-Asia (ISGT Asia)*, May 2019, pp. 3788–3792.
- [94] K. J. Ross, K. M. Hopkinson, and M. Pachtar, "Using a distributed agent-based communication enabled special protection system to enhance smart grid security," *IEEE Trans. Smart Grid*, vol. 4, no. 2, pp. 1216–1224, Jun. 2013.
- [95] J. Lu, D. Xie, and Q. Ai, "Research on smart grid in China," in *Proc. Transmiss. Distrib. Conf. Expo., Asia Pacific*, 2009, pp. 1–4.
- [96] C. Gellings, "Using a smart grid to evolve a reliable power system," in *Proc. IEEE Int. Rel. Phys. Symp.*, May 2010, pp. 1–2.
- [97] D.-Q. Sun, J.-W. Zheng, T. Zhang, Z.-J. Zhang, H.-T. Liu, F. Zhao, and Z.-J. Qiu, "The utilization and development strategies of smart grid and new energy," in *Proc. Asia-Pacific Power Energy Eng. Conf.*, 2010, pp. 1–4.
- [98] J. Yang, H. Liu, K. Ma, B. Yang, and J. M. Guerrero, "An optimization strategy of price and conversion factor considering the coupling of electricity and gas based on three-stage game," *IEEE Trans. Autom. Sci. Eng.*, early access, May 25, 2022, doi: 10.1109/TASE.2022.3171446.
- [99] H. K. Karegar, H. A. Abyaneh, V. Ohis, and M. Meshkin, "Pre-processing of the optimal coordination of overcurrent relays," *Electr. Power Syst. Res.*, vol. 75, nos. 2–3, pp. 134–141, Aug. 2005.
- [100] M. Ezzeddine and R. Kaczmarek, "Reduction of effect of coordination constraints in the linear optimization of operating times of overcurrent relays," in *Proc. 14th IEEE Medit. Electrotech. Conf.*, May 2008, pp. 707–712.
- [101] A. Tjahjono, D. O. Anggriawan, A. Priyadi, M. Pujiantara, and M. H. Purnomo, "Digital overcurrent relay with conventional curve modeling using Levenberg–Marquardt backpropagation," in *Proc. Int. Seminar Intell. Technol. Appl. (ISITIA)*, May 2015, pp. 171–176.
- [102] R. Ramaswami, S. Venkata, M. Damborg, and J. Postforoosh, "Computer aided transmission protection system design Part II: Implementation and results," *IEEE Trans. Power App. Syst.*, vol. PAS-103, no. 1, pp. 60–65, Jan. 1984.
- [103] H. Wan, K. K. Li, and K. P. Wong, "An adaptive multiagent approach to protection relay coordination with distributed generators in industrial power distribution system," *IEEE Trans. Ind. Appl.*, vol. 46, no. 5, pp. 2118–2124, Sep. 2010.
- [104] A. Liu and M.-T. Yang, "A new hybrid nelder-mead particle swarm optimization for coordination optimization of directional overcurrent relays," *Math. Problems Eng.*, vol. 2012, Jan. 2012, Art. no. 456047.
- [105] M. Zellagui and A. Y. Abdelaziz, "Optimal coordination of directional overcurrent relays using hybrid PSO-DE algorithm," *Int. Elect. Eng. J.*, vol. 6, no. 4, pp. 1841–1849, 2015.
- [106] M. Sulaiman, A. Ahmad, A. Khan, and S. Muhammad, "Hybridized symbiotic organism search algorithm for the optimal operation of directional overcurrent relays," *Complexity*, vol. 2018, pp. 1–11, Jan. 2018.

- [107] H. Saberi and T. Amraee, "Coordination of directional over-current relays in active distribution networks using generalised benders decomposition," *IET Gener., Transmiss. Distrib.*, vol. 11, no. 16, pp. 4078–4086, Nov. 2017.
- [108] A. Mahari and H. Seyedi, "An analytic approach for optimal coordination of overcurrent relays," *IET Gener., Transmiss. Distrib.*, vol. 7, no. 7, pp. 674–680, Jul. 2013.
- [109] A. Tjahjono, D. O. Anggriawan, A. Priyadi, M. Pujiantara, and M. H. Purnomo, "Overcurrent relay curve modeling and its application in the real industrial power systems using adaptive neuro fuzzy inference system," in *Proc. IEEE Int. Conf. Comput. Intell. Virtual Environ. for Meas. Syst. Appl. (CIVEMSA)*, Jun. 2015, pp. 1–6.
- [110] A. Sahrin, A. Tjahjono, M. Pujiantara, and M. H. Purnomo, "The modeling of directional overcurrent relay in loop system using cascade forward neural network," in *Proc. Int. Seminar Intell. Technol. Appl. (ISITIA)*, Aug. 2017, pp. 69–74.
- [111] D. O. Anggriawan, E. Prasetyono, F. Fahrissi, A. Budikarso, A. Tjahjono, and H. R. P. Rogoondo, "Digital overcurrent relay implementation with non-standard inverse curve modelling using adaptive neuro fuzzy inference system," in *Proc. Int. Conf. Artif. Intell. Inf. Technol. (ICAIIIT)*, Mar. 2019, pp. 327–330.



KIMMO KAUHANIEMI (Member, IEEE) received the M.S. and Ph.D. degrees in electrical engineering from the Tampere University of Technology, Finland, in 1987 and 1993, respectively. He has been previously employed by the ABB Corporate Research Center and the VTT Technical Research Centre of Finland. He is currently a Professor of electrical engineering with the University of Vaasa, where he also leads the Smart Electric Systems Research Group. His research interests include power system transient simulation, protection of power systems, grid integration of distributed generation, and microgrids.



SUZANA PIL RAMLI received the B.E. and M.E. degrees in power electrical engineering from University Technology Malaysia (UTM), in 2003 and 2010, respectively, and the Ph.D. degree in electrical engineering from the University of Malaya. Her research interests include power system protection scheme, localize fault analysis, load shedding, distributed generation, and renewable energy.



ALIREZA POURDARYAEI received the bachelor's degree in electrical and electronic engineering from Hormozgan University, Iran, in 2010, and the M.Eng.Sc. degree in industrial electronic and control and the Ph.D. degree in power systems from the University of Malaysia (UM), in 2014 and February 2020, respectively. His current research interests include distribution automation, artificial intelligence (AI), energy management, and forecasting.



and control, namely wide area monitoring and protection, smart grid applications, earth fault management, cyber security, and islanding detection.

MEYSAM PASHAEI received the B.Sc. degree in electrical engineering from the Iranian Center of Excellence in Power Systems, Azad University (South Tehran Branch), Tehran, Iran, in 2013, and the M.Sc. degree in electrical engineering from the Amirkabir University of Technology (Tehran Polytechnic), Tehran, in 2019. He is currently a Project Researcher with the School of Technology and Innovations, University of Vaasa, Finland. His research interests include power system protection



MEHDI DARYAEI received the bachelor's degree in electrical engineering and the M.Eng.Sc. degree in power system from the Technical and Engineering Campus of Shahid Beheshti University (formerly known as the Power and Water University of Technology) (PWUT), Iran, in 2010 and February 2013, respectively. He is currently pursuing the Ph.D. degree in power system with the Iran University of Science and Technology (IUST). His current research interests include smart grid applications, distributed generation, machine learning (ML), load forecasting, power system planning and optimization, power flow analysis, power system stability, and frequency control.



His current research interests include smart grid applications, wide-area monitoring, protection, and control, distributed generation, power system stability, and frequency control.

MAZAHER KARIMI (Senior Member, IEEE) received the Ph.D. degree in electrical energy and power systems from the University of Malaya, Kuala Lumpur, Malaysia, in 2013. He worked as a Postdoctoral Research Fellow at the University of Malaya, in 2014 and 2015. He joined The University of Manchester, a Research Associate, from 2016 to 2017. From 2017 to 2020, he was an Assistant Professor at Gonbad Kavous University, Iran. He is currently an Assistant Professor with



the School of Technology and Innovations, University of Vaasa, Finland. His current research interest includes protection and stability of power grids.

...