

Received 15 October 2022, accepted 12 November 2022, date of publication 7 December 2022, date of current version 12 December 2022.

Digital Object Identifier 10.1109/ACCESS.2022.3227433

TOPICAL REVIEW

Microbial Fuel Cell as a Future Energy Source: A Review of Its Development, Design, Power Generation, and Voltage Reversal Control Mechanism

GANESAN V. MURUGESU¹, SAIFUL NIZAM KHALID¹,
AND HUSSAIN SHAREEF², (Member, IEEE)

¹Faculty of Engineering, School of Electrical Engineering, Universiti Teknologi Malaysia, Johor Bahru 81310, Malaysia

²Department of Electrical and Communication Engineering, College of Engineering, United Arab Emirates University, Al Ain, United Arab Emirates

Corresponding author: Hussain Shareef (shareef@uaeu.ac.ae)

This work was supported in part by the Public Service Department of Malaysia, and in part by the United Arab Emirates University.

ABSTRACT Microbial fuel cells (MFCs) are a promising technology that use microorganisms to generate electrical energy from chemical energy. However, ultralow-power production and high-cost materials have become significant drawbacks in MFC development. Therefore, various methods have been proposed for increasing the output power of MFC. Among them, stacking multiple cells in a series has been suggested as the most promising method for generating high power in MFC. However, voltage reversal (VR) has become an issue that limits the electrical power generation in stacked MFC. Thus, this study investigates and discusses the actual cause of the voltage reversal phenomenon in a series-stacked MFC from the perspective of electron and proton transfer mechanisms. This paper also discusses the electronic control methods used to eliminate VR and challenges in MFC development. Furthermore, this review also briefly explains the evolution of MFC development stages and the factors influencing MFC performance. It is found that solving the VR issue in a series of stacked MFC is a significant factor in boosting MFC technology in the commercial world. In addition, reducing material and operational costs will promote future implementation of MFCs.

INDEX TERMS Electron and proton transfer mechanisms, microbial fuel cell, series-stacked, substrate concentration, voltage reversal.

I. INTRODUCTION

Excessive energy demands and environmental contaminants have accelerated the research and development of renewable and sustainable energy sources [1]. Currently, solar, biogas, wind, fuel cell, hydro, and geothermal energy generation technologies are commercially available as replacements for fossil fuels that support the current energy demand [2]. Among other alternatives, microbial fuel cells (MFCs) are becoming popular, using exoelectrogens to generate electrical energy while removing pollutants [3]. However, the development of MFCs as viable energy sources faces many challenges. The core direction in MFC research includes methods

to improve electrical power generation in MFC systems, control of unstable MFC voltage, mitigation of multiple losses in the design, detection, and prevention of the voltage reversal phenomenon, and utilization of low-cost materials [2], [4].

In this review, an extensive overview of different aspects of MFCs, including their evolution, design considerations, mechanisms of energy generation, stacking, voltage reversal phenomena, and attempts to enhance MFC performance, is presented and discussed. Several well-known research databases were accessed considering four key objectives:

- a. Focus on the development of MFC
- b. Understand various MFC designs and operations
- c. Investigate the working principles of MFC
- d. Identify approaches used to enhance the performance of MFCs.

The associate editor coordinating the review of this manuscript and approving it for publication was Qiang Li¹.

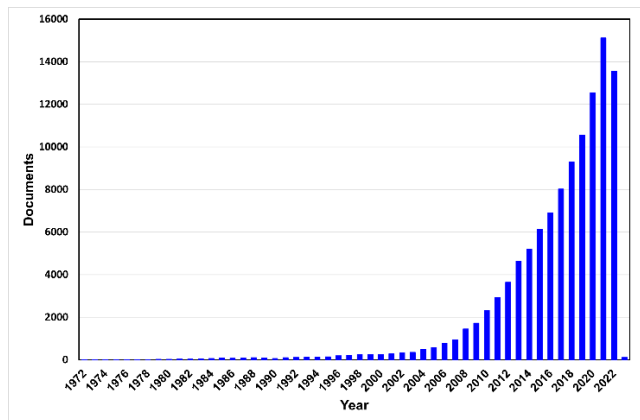

FIGURE 1. Number of Documents Presented on MFC.

The remainder of this paper is organized as follows. Section II presents the review methodology and Section III presents the development of the MFC. Section IV presents the exceptional reactor design of the MFC and Section V presents the working principles of the MFC. The voltage reversal control mechanism is discussed in Section VI. Finally, the challenges and future directions of MFC are discussed in Section VII, followed by the conclusions in Section VIII.

II. REVIEW METHODOLOGY

This section discusses the methods used to analyze research trends in MFC since 1971.

A. GATHERING LITERATURE

In the first stage, the database of SCOPUS, ScienceDirect Journal, Web of Science, SpringerLink Journal, and IEEE Xplore Digital Library were searched with “microbial fuel cell” as the main terms to obtain the relevant manuscripts. Then, “voltage reversal,” “wastewater treatment,” and “series-stacked” are used as subterms to filter and reduce the number of articles close to the research title. Finally, the latest articles published in the last ten years were filtered again to review the latest developments in the MFC field. Furthermore, some information is gathered from websites and books as needed.

B. RESEARCH TRENDS IN MFC RESEARCH AND DEVELOPMENT

Research and development of MFC has drastically increased over the last 20 years. The number of documents published increased from a few hundred to a few thousand each year, starting in 2000. Almost 80% of these documents were published as research articles in various journals, as shown in Fig.1 and Fig.2.

Fig. 3 shows the subject areas focusing on MFCs, accounting for 17.9% of the total documents related to environmental topics related to wastewater treatment. The most popular subjects in MFC research are chemical engineering, energy, and chemistry. The analysis showed that China is the leading

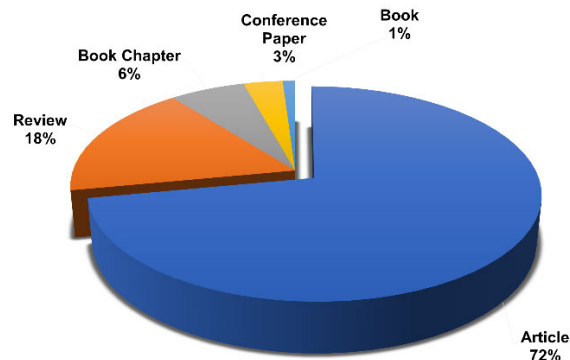

FIGURE 2. Type of Documents Presented on MFC.

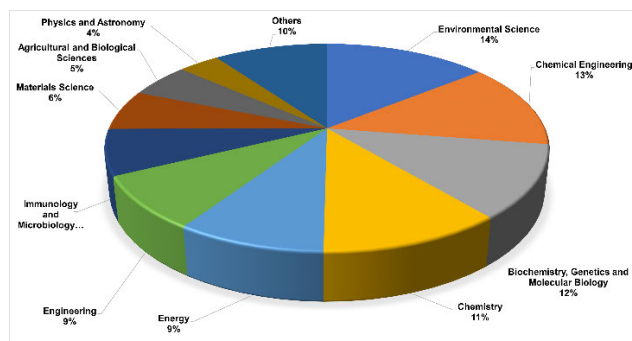

FIGURE 3. Documents Published on MFCs based on Subject Area.

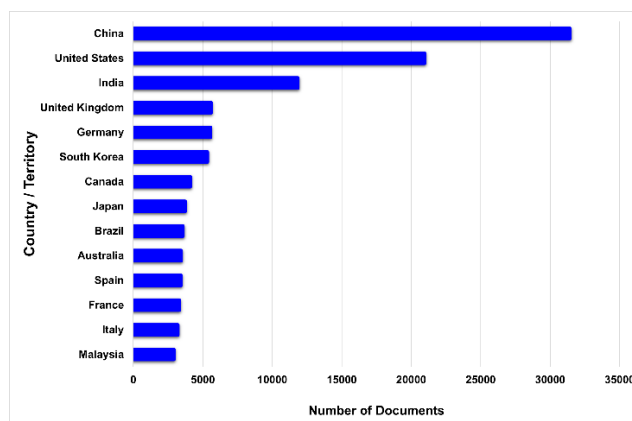

FIGURE 4. Documents by Country on MFC research.

country in MFC research, with almost 4,000 documents published related to MFC, as shown in Fig.4. The United States, India, and South Korea are also the leading countries in MFC research.

III. FUNDAMENTALS OF MFC DEVELOPMENT

The development of MFC began in the 18th century with the idea of animal electricity from Luigi Galvani. However, the actual concept and targeted research on MFCs began in the 2000s.

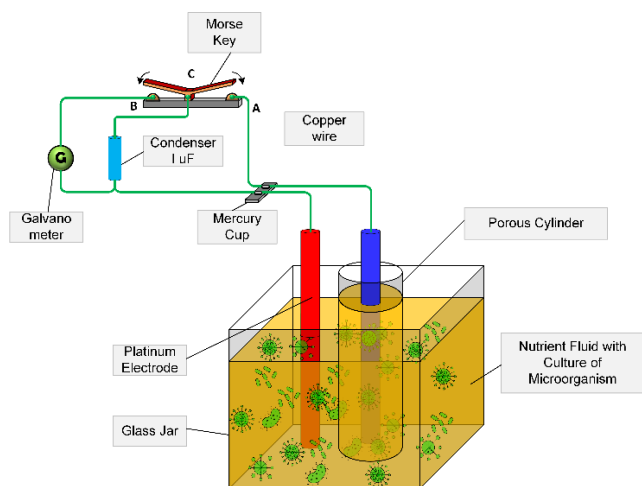

FIGURE 5. MFC by M.C. Potter, an illustration by the author.

A. EVOLUTION OF MFCS

An MFC uses the basic concept of a Galvanic Cell, which generates electrical energy directly from chemical energy with the aid of microorganisms [5], [6]. The term MFC was first proposed in 1962 by Davis and Yarbrough in their paper “Preliminary Experiment on a Microbial Fuel Cell.” They observed that microbes react with hydrocarbons to produce electrical energy [7]. However, the initial research that led to MFC began in the early 18th century with the birth of galvanic cells by Luigi Galvani. The idea of generating electricity from chemical reactions was started by Luigi Galvani and Alessandro Volta at the end of the 18th century [8], [12].

However, the idea of using microorganisms to generate electricity was initiated by Potter [13] in 1911 with the experimental setup illustrated by the author in Fig. 5. In his experiment, the nutrient fluid was filled with a microorganism culture in a glass jar. A platinum electrode was immersed inside the nutrient fluid, which acted as the anode. The same material was used as a cathode dipped into the liquid inside the porous cylinder, which acted as a proton exchange membrane (PEM). When the C-A terminal is closed, current flows from the cathode to the anode, charging the capacitor. When the C-B terminal of the switch is closed, the capacitor is discharged through a galvanometer [13]. However, no analysis has been performed to understand the details of the proton and electron transfer mechanisms.

Davis and Yarbrough explored the role of microbes that use hydrocarbons as their food to generate electrical energy. In this experiment, a different type of reactor was designed and divided into three main parts. The left-hand side is called a biological half-cell, supplied with continuous nitrogen. The middle part is called the buffer zone and is bubbled with Oxygen-free Nitrogen to prevent oxygen from reaching the biological half-cell. The right-hand side is called the oxygen half-cell, bubbled continuously with oxygen. All three compartments were filled with 1% Sodium Chloride (NaCl) with 0.05 M Phosphate buffer at pH 7. The researchers

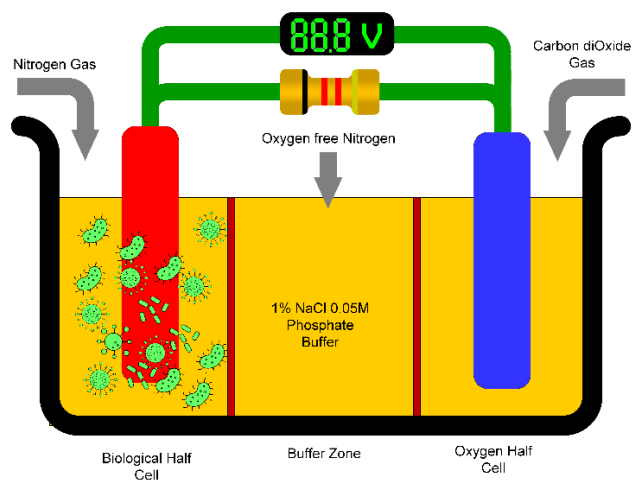

FIGURE 6. Experimental Setup by Davis et al. – Illustration by author.

reported three different types of experiments using (a) Glucose Oxidase, (b) Escherichia Coli, and (c) Nocardia as added microbes in the glucose substrate using a 1000 ohms load. The experiment shows that using microorganisms generates a higher voltage than the usual solution [7]. The MFC design introduced by Davis is shown in Fig. 6.

Research on MFC exploded when NASA announced a study to develop a fuel cell that used human waste to generate electricity in 2004 [14]. In 2006, researchers from the University of Florida investigated the possibility of converting human waste into methane to produce electricity in space [15]. A brief overview of the MFC is presented in Fig. 7.

B. ADVANTAGES AND DISADVANTAGES OF MFCS

The most notable advantage of MFC is that they can simultaneously remove pollutants by purifying wastewater while producing electrical energy. It is estimated that wastewater treatment plants contain approximately 930% more power compared to the power used by the total operations [16]. Reference [17] demonstrated the use of a two-chamber MFC to generate 107% electrical energy in a brewery wastewater plant compared to the operational energy required for an overall Chemical Oxygen Demand (COD) removal of 91.88%. Reference [18] showed that an air cathode MFC composed of a carbon brush anode with a twisted titanium wire and platinum-coated carbon cloth cathode managed to remove $89 \pm 1.4\%$ of total COD and $78 \pm 1.5\%$ of soluble COD at 1.25 organic load in the seafood processing industry in Saudi Arabia, with the highest power density of $530 \pm 2.4 \text{ mW/m}^2$.

Another significant advantage of MFCs is that they can operate under mild temperatures and pH conditions [19]. Temperature is the most vital parameter to be maintained to achieve an optimal output in any MFC system. The MFC operates well at room temperature to achieve its optimal output. The average temperature reported for MFC operation is approximately 20–32 °C [20], [25]. Generally, most bacteria used in MFCs can achieve optimal growth at one or two pH

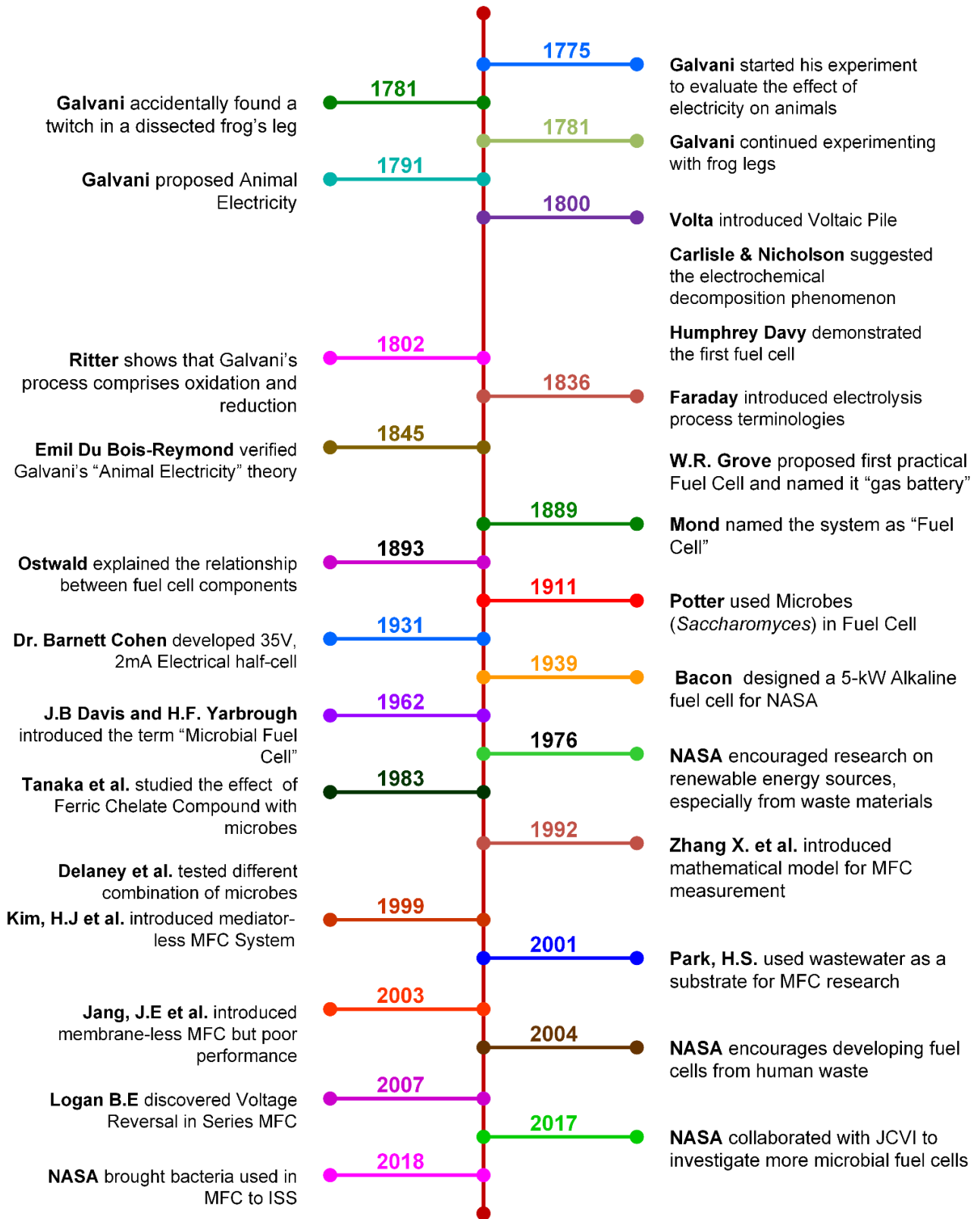

FIGURE 7. Evolution of MFCs since 1775.

units from a neutral value of 7.0 [26]. This value is favorable for MFC development using wastewater, where the pH for most wastewater is near-neutral and varies between 6.0–8.0

[27]. Another unique advantage of MFC over other fuel cells is their ease of customizability. In an MFC, the optimal output can be reached by adjusting

- reactor size and configuration
- reactor volume
- electrode type and size
- membrane type and size
- substrate composition
- catalyst
- pH value and
- temperature

These unique characteristics have opened a wide area of research into MFC [2]. Other advantages of MFCs are [28],

- direct chemical to electrical energy generation
- no sludge aeration
- easy installation in a rural area
- lower sludge treatment
- easy monitoring
- self-regeneration of microorganisms
- low carbon footprint, and
- water reclamation

Even though MFC have enormous advantages, some limitations still hinder their access to the commercial market [3]. Two significant limitations in MFC development are (a) ultralow power generation and (b) high-cost materials. The highest Open Circuit Voltage (OCV) generated by a single cell of MFC is only 1.1V. However, in practice, this value is reported to be around 0.2 V to 0.8 V [29], [30] due to the significant losses/ overpotential in the system, such as ohmic losses, activation losses, and concentration losses [4], [31], [34]. At the same time, the internal resistance is also very high because of the redox reaction, which reduces the MFC output power ($P = V^2 / R$). Therefore, the potential difference between the electrodes must be increased to improve power generation or the internal resistance should be reduced. Removing the membrane, modifying the reactor configuration, scaling up, and stacking several units in series or parallel have been attempted to strengthen power generation from MFC [2]. However, building a large-scale MFC or simply connecting several units of MFCs in series or parallel cannot produce enormous output power without an optimal power management system to support the energy harvesting process in MFC design [35].

Another major drawback of the MFC design is its high material cost. A basic MFC consists of reactors (anodic and cathodic), electrodes, PEM, substrates, mediators, and microorganisms [36]. Thus, many system design modifications have been considered to reduce the material cost, such as reducing from two chambers to a single chamber, using low-cost electrodes, membrane-less MFC, and mediator-less MFC. Liu H. and Logan. B.E. [37] introduced an air cathode MFC with only a single anodic chamber (single-chamber MFC) and without a proton exchange membrane to reduce the material cost. Mediator-less MFCs have been introduced when exoelectrogens such as *Geobacter sulfurreducens* (KN400) were found suitable for MFCs [38]. This microorganism can transfer electrons directly to electrodes using nanowires [39]. However, the cost remains a significant

TABLE 1. Advantages and limitations of MFC.

| Advantages of MFC | Limitations in MFC |
|---|--|
| <ul style="list-style-type: none"> • Remove pollutants while generating electricity • Direct chemical to electrical energy • Can work under mild conditions • Easy customizable • No sludge aeration • lower sludge treatment • Easy installation • Easy monitoring • self-regeneration of microorganisms • water reclamation | <ul style="list-style-type: none"> • Very lower power generation • High-cost material • High internal resistance • membrane fouling • electrochemical limitation • mass transport limitation between anode & cathode |

issue in MFC design with ultralow power generation. Other limitations of MFCs include high internal resistance, high dissolved oxygen permeability, membrane fouling, electrochemical limitations, and mass transport limitations [36], [40]. Table 1 summarizes the advantages and disadvantages of MFC.

C. FACTORS THAT INFLUENCE MFC PERFORMANCE

Generally, many biological, chemical, physical, and electrical parameters influence the electricity generation in MFC. A powerful MFC-based energy-harvesting system can be developed if these parameters are optimally maintained with sufficient modifications and existing resources [3]. The substrate concentration and reactor design are the most important elements influencing the output of MFCs. Temperature, pH, type of microorganism, substrate mixing, membrane selection, and feeding duration were also reported as other elements.

1) SUBSTRATE CONCENTRATION

The substrate concentration is a significant element that determines energy generation in MFC. Many studies have highlighted that an increase in the substrate concentration increases the power density in MFC, regardless of the reactor design. For example, Ni et al. tested three different concentrations of swine wastewater to study the effect of substrate concentration on MFC [41]. The results show that the MFC output voltage increases with the substrate concentration. Reference [42] reported the use of different contaminant concentrations between 215–813 mg/L and proved that an increased concentration generates a higher voltage. Table 2 lists the experimental results obtained by Wang et al. References [43] and [44] also proved that a higher value of the substrate concentrate generates a higher power density in MFC.

TABLE 2. Value of average Voltage generated with different substrate concentrations for different types of anode material.

| Substrate Concentration (mg/L) | Anode Type | | | |
|--------------------------------|------------------------|---------------------------|--------------------|--------------------|
| | Carbon Fiber Felt (mV) | Stainless Steel Mesh (mV) | Graphite rode (mV) | Foamed Nickle (mV) |
| 215 | 97.7 | 17.6 | 23.3 | 79.4 |
| 423 | 148.2 | 32.1 | 38.7 | 112.6 |
| 813 | 183.2 | 54.9 | 54.9 | 146.2 |

2) EFFECT OF TEMPERATURE

MFCs show excellent performance at mild temperatures (25–35 °C). According to Song *et al.*, the highest power density of 54 mW/m² was achieved at 25 °C compared to 35 °C and 45 °C. They also observed that a lower power density was recorded when the system was switched back to the initial temperature, thus concluding that the performance of MFC is significantly influenced by temperature changes [45]. In a similar work, Tee *et al.* stated that the ideal operating temperature for an MFC-adsorption hybrid system is 35 °C [46]. They tested the system between 20–55 °C (at 5 °C intervals) and achieved the highest power density of 74 ±6 mW/m³ at 35 °C. In another investigation, Tremouli *et al.* used a double-chamber MFC (DCMFC) to show that the optimal output of the MFC is at 35 °C and achieved the highest power density of 59 mW/m². According to them, microbial activity is not responsive to a slight change in temperature because the maximum power density remains at 36mW/m² at a lower temperature (24–26 °C) and shows changes at 30 °C and above [47]. Wang *et al.* investigated the temperature variation between 25–45 °C using DCMFC [48] and observed that optimal performance was attained at 35 °C with a power density of 0.54 W/m³. The low performance at higher temperatures is caused by the destruction of exoelectrogens at higher temperatures. Hamed *et al.* reported similar results in an investigation using a double-chamber MFC with different electrode materials [49]. They tested the performance of MFC between 20–45 °C (at 5 °C intervals) and achieved the highest power density at 30 °C and 35 °C. At these temperatures, the mass transfer limitation increased microbial activity. When the temperature increased beyond this level, the microbes were destroyed, lowering the performance.

3) EFFECT OF PH VALUE

The concentration of hydrogen ions in a substance or the pH value is also a major factor influencing MFC performance. Reference [50] reported that the optimal pH value for ideal MFC performance is between 8–10. The effect of anodic pH was investigated by varying the pH from 3–13 using a marine consortia-based dual-chamber MFC. In related work, Raghavulu *et al.* [51] used acidophilic (pH = 6), neutral (pH = 7), and alkaline (pH = 8) in the experiment and reported that acidophilic (pH = 6) gave the best result compared to pH 7 and 8. This result contradicts recent research, which suggests that pH 8–10 is the best value for optimal per-

TABLE 3. pH value for optimal microbial growth in MFC.

| Substrate | pH Value | Maximum Voltage (mV) | References |
|---------------------------------------|----------|----------------------|------------|
| Dewatered sludge with food waste | 8 | 807.0 | [53] |
| Digester sludge from WWT works | 9 | 197.2 | [52] |
| River wastewater | 8 | 1132.0 | [54] |
| Hospital wastewater | 9 | 1016.0 | [54] |
| Chemical wastewater with Ferricyanide | 6 | 470.0 | [51] |

formance. The latest research from T. E. Igboamalu *et al.* [52] supported the work reported in [50] and [51] and concluded that the initial pH value plays an essential role in determining the performance of the MFC. Reference [52] strongly agreed that an initial pH value below seven or above nine will produce higher proton liberation, causing the accumulation of more positive ions in the anode chamber, increased internal resistance, and reduced power generation. Table 3 shows the latest studies that showcase the effect of pH on MFC performance, clearly indicating that the optimal pH value for the MFC system is between 6–9.

D. FAULT IN MFC AND DETECTION METHOD

Faults in electrochemical systems are common. In MFC, the main fault is caused by the failure of hardware malfunction.

1) COMMON FAULTS DETECTED IN MFCs

a: BIOFOULING DEVELOPMENT

Biofouling is a phenomenon in which biofilms form on moist surfaces. Therefore, in MFC, biofilms commonly develop on the cathode surface and PEM. Biofilm formation in the cathode can reduce electron transfer to the cathodic substrate, thereby lowering the reduction process in the cathodic chamber [55]. The PEM is the intermediate layer between the anodic and cathodic chambers, allowing proton transfer to the cathodic chamber during the reduction process. Thus, when a PEM fails, it reduces the cation transfer rate to the cathodic chamber and causes a decrease in the overall performance. Nafion 117 has excellent antifouling capacity, lower internal resistance, and higher conductivity to cations and is the most used PEM in MFC designs [56].

b: ELECTRODE CORROSION

An MFC is an electrochemical system that transfers electrons from one metal (anode) to another (cathode) through an external wire. Copper is commonly used as an external wire, while various metals have been used as electrodes in MFCs.

Therefore, corrosion of the copper wire and electrodes in the MFC can increase the internal resistance, thus affecting the power generation in MFC [56].

Owing to the ultra-low power generation in MFC, stacking up several units in series or parallel is suggested as a promising technique to increase the performance of MFC. However, connecting one or more units in series or parallel can cause a voltage reversal in one or more unit cells. This phenomenon can generate bio-anode corrosion in stacked MFC and affect the overall system performance [29].

c: SUPPORTING EQUIPMENT FAILURE

Several supporting devices are used to maintain MFC performance, depending on the reactor design. The most common supporting devices used in a double-chamber MFC are an air pump in the cathodic chamber and a magnetic stirrer in the anodic chamber. The cathodic chamber used an air pump to supply continuous and sufficient oxygen to the cathodic substrate to perform a reduction reaction to form water. Failure of the air pump can cause insufficient oxygen in the cathodic chamber, which lowers the electricity production in the system. The magnetic stirrer at the bottom of the anodic chamber supports the microorganisms in the anodic substrate to maintain contact with the organic matter. The failure of this magnetic stirrer can reduce the electron production by microorganisms and lower the electricity generation in the MFC [57].

2) FAULT DETECTION METHOD

To date, only three methods have been proposed for detecting faults in MFC. The first two methods, proposed by Yan et al. and Fan *et al.*, using frequency doubling wavelet and fault tree MFC algorithm were criticized by Ma et al. [56] According to them, the previous two methods cannot produce an accurate result and take longer to identify faults. Therefore, they proposed a “Microbial Fuel Cell Model” to diagnose faults in MFCs. They used a three-layer wavelet packet decomposition method to determine the frequency range and an SOM neural network to construct a pattern classification [57].

IV. DESIGN OF MFC REACTOR

Reactor design plays a prominent role in the design of low-cost MFCs [58]. Many different types of MFCs have been designed to improve output power. The reactor volume, type of membrane or membrane-less, electrode distance, cathode position (inside the reactor or air-cathode), anode and cathode structure, and reactor arrangement are some of the configurations that should be considered when designing an optimal MFC [59]. However, the success of MFCs as alternative power sources is still under research and development because of many unsolved issues.

To find the most superior MFC designs, the author used the Scopus database to find the most cited literature in the last five years under different types of MFCs. Then, the eight most famous reactor types used in the research were selected from the search results, as shown in Table 4. The following

TABLE 4. Most used reactor types in research in last five years of MFC designs.

| Reactor Type | No. of Articles published in last 5 years |
|--------------------------|---|
| Dual-Chamber MFC | 104 |
| Single-Chamber MFC | 408 |
| Sediment MFC | 215 |
| Constructed Wetlands MFC | 196 |
| Parallel-stacked MFC | 111 |
| Photosynthetic MFC | 81 |
| Up-Flow MFC | 48 |
| Series-stacked MFC | 20 |

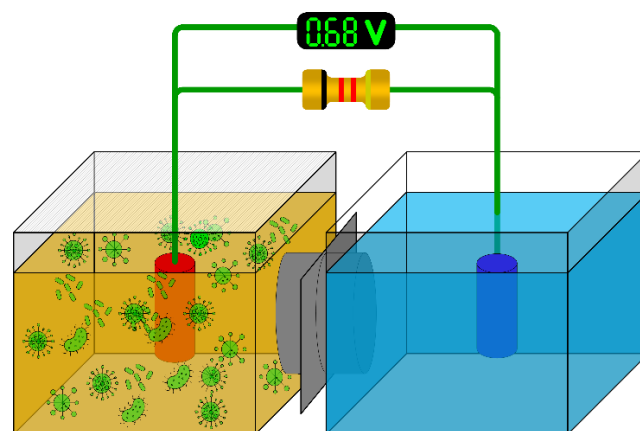

FIGURE 8. Dual-Chamber MFC.

subsections provide details of these designs, summarized in Table 5.

A. DUAL CHAMBER MFC (DCMFC)

The dual-chamber MFC (DCMFC), as shown in Fig. 8, consists of two compartments, an anodic and a cathodic chamber separated by a PEM [3], [36]. The double chamber was the first introduced model but was later modified into a single chamber to reduce the material cost [39]. To date, many types of dual-chamber MFCs have been presented. The H-type MFC is the most commonly designed DCMFC, consisting of two compartments connected by a membrane bridge in the middle. The anodic chamber is anaerobic, where the oxidation process produces electrons and the reduction process occurs in the cathodic chamber to produce clean water [3]. The DCMFC is the most suitable design for educational purposes because it consists of a comprehensive system with all essential components of the MFC. However, it is not cost-effective compared with a single-chamber MFC, which can be constructed at a lower cost.

TABLE 5. Advantages and disadvantages of selected MFCs.

| MFC Type | Advantages | Disadvantages |
|--------------------------|---|--|
| Dual-Chamber MFC | The first MFC model. Comprehensive. Suitable for educational purposes. | Not cost Effective. Cathodes need regular replacement. |
| Single Chamber MFC | Single reactor reduces the total cost of the material. Membraneless design is more economical. Design is not complex. | Lower coulombic efficient |
| Sediment MFC | Most suitable and economical design | Not suitable for wastewater treatment due to high internal resistance |
| Constructed Wetlands MFC | Low-cost model | Complex design and not customizable. |
| Parallel stacked MFC | Can produce higher current | Charge reversal is possible in this model reduces the power generation |
| Photosynthetic MFC | One of the promising models | Not suitable for countries with low sunlight. Cathodes need regular replacement. |
| Up-Flow MFC | | The design process is very complex. Has high internal resistance, Need and external pump to pump in influent |
| Series stacked MFC | Can generate higher voltages | Voltage reversal can reduce the resultant voltage and can damage the anode electrode. |

B. SINGLE CHAMBER MFC (SCMFC)

A single-chamber MFC (SCMFC), as shown in Fig. 9, was modified from the double-chamber design to reduce the cost and connect the cathode directly to air to absorb free oxygen [39]. This configuration removes the cathodic chamber but maintains other components such as electrodes, PEM (optional), microorganisms, and mediators. This design is simple and low-cost compared to other configurations. Some SCMFCs use a PEM as a separator between the anode and cathode chambers, but most SCMFCs are designed without a PEM [60], [62]. The membrane-less SCMFC is the most economical design, and the main cost of the MFC design for the PEM has been discarded. However, SCMFCs have a lower coulombic efficiency owing to oxygen diffusion into the anode.

C. SEDIMENT MFC (SMFC)

The sediment MFC was designed based on a naturally existing ecosystem of water and sediment, as shown in Fig. 10. The anode electrode is placed inside the sediment and the cathode electrode is placed in the water area; no membrane

was used in this setup. A copper wire was then connected between the anode and cathode to complete the circuit. Thomas et al. constructed an early SMFC using a cylindrical polyvinyl chloride tube (PVC) with graphite granules as the anode and a graphite rod as the cathode [63]. Consequently, SMFCs are one of the most promising, simple, and cost-effective designs. Unfortunately, this model is unsuitable for wastewater treatment plants owing to its high internal resistance [64].

D. CONSTRUCTED WETLAND MFC (CWMFC)

Yadav et al. introduced a Constructed Wetland MFC, as shown in Fig. 11, combining the double chamber and photosynthetic model, comprising anodic and cathodic chambers separated by glass wool. The cathodic chamber was placed at the top, with the anodic chamber at the bottom. The upper layer was left open, and the lower layer was sealed with epoxy material. Consequently, the cost of glass wool is relatively lower than that of PEM materials and can thus be categorized as a low-cost model [65].

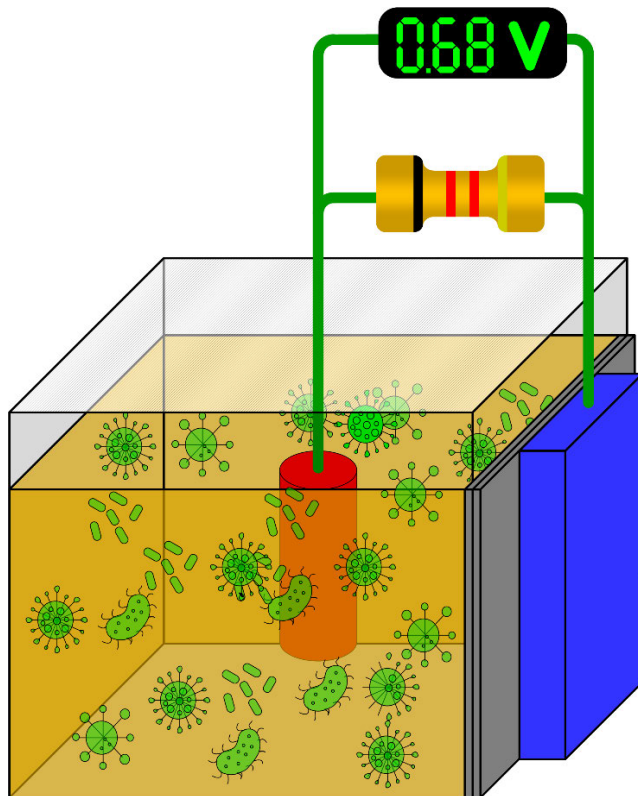

FIGURE 9. Single-Chamber MFC.

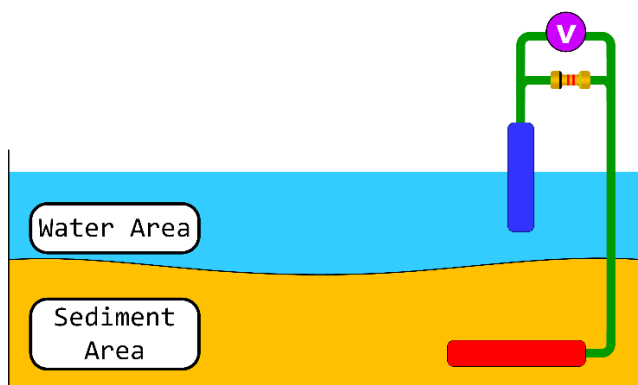

FIGURE 10. Sediment MFC.

E. PARALLEL-STACKED MFC

In a parallel-stacked MFC, as shown in Fig. 12, the anodes were connected to the adjacent anodes and the cathodes were connected to the adjacent cathodes. This model was designed to accumulate the current in the system. Aelterman et al. first tested six MFCs stacked in series and parallel and concluded that the current was higher in the parallel configuration and the voltage was higher in the series connection. However, the output powers of both structures are almost identical [32].

F. PHOTOSYNTHETIC MFC

Strik et al. introduced a plant MFC that uses plants and bacteria to produce electricity, as shown in Fig. 13. The plant uses solar energy to produce rhizodeposition, which is used by the bacteria in the MFC to generate electricity using fuel cells

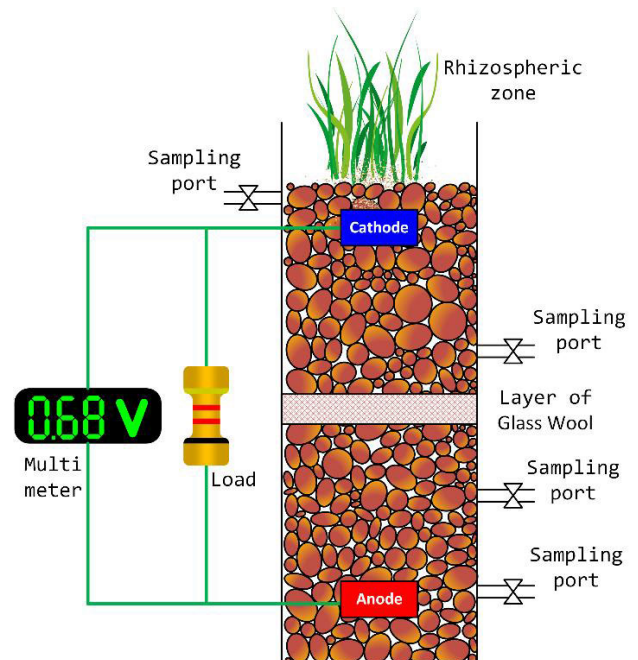

FIGURE 11. Constructed Wetland MFC.

[66]. The same concept was used by Yang et al. to produce a Photosynthetic MFC (PMFC) using algal cultivation with multiple anodes [67]. Nayak et al. designed a 3-compartment MFC where the first compartment contained microalgae. This pre-treatment compartment was exposed to an LED strip and supplied the influent to the anodic chamber. They also added microalgae to cathodic substrates [68]. These models are similar to double-chamber MFC in terms of cost, power generation, and design complexity.

G. UP-FLOW MFC (UFMFC)

He et al. [69] first introduced an up-flow MFC consisting of vertically connected cylindrical chambers, as shown in Fig. 14. The cathodic chamber was located at the top, whereas the anodic chamber was located at the bottom. The PEM was then placed in the middle at a 15° angle to the horizontal plane to avoid the accumulation of gas bubbles.

The influent was pumped at the bottom, and the effluent was released in the middle of the anodic chamber. Air was supplied to the top of the cathodic chamber, and a copper wire was connected to the anode and cathode. Later, Thung et al. [70] introduced a membrane-less up-flow MFC similar to a UFMFC, but instead of a PEM, 6 mm gravel was used as an anodic and cathodic separator. Three anodes were placed in this setup using carbon felt, while platinum-coated carbon paper, carbon felt, and carbon flakes were used as cathode electrodes. The influent was pumped from the bottom of the anodic chamber to the cathodic chamber. A copper wire connected the anode and cathode to complete the circuit via a load. However, this model has a large internal resistance, which reduces power density. The complexity of the design process is a significant disadvantage.

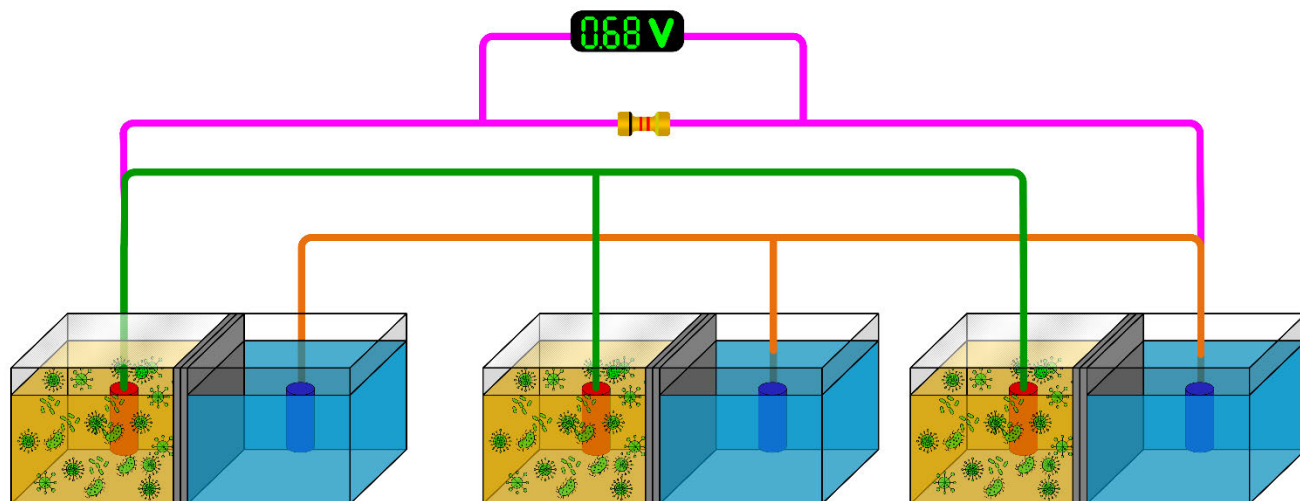

FIGURE 12. Parallel-Stacked MFC.

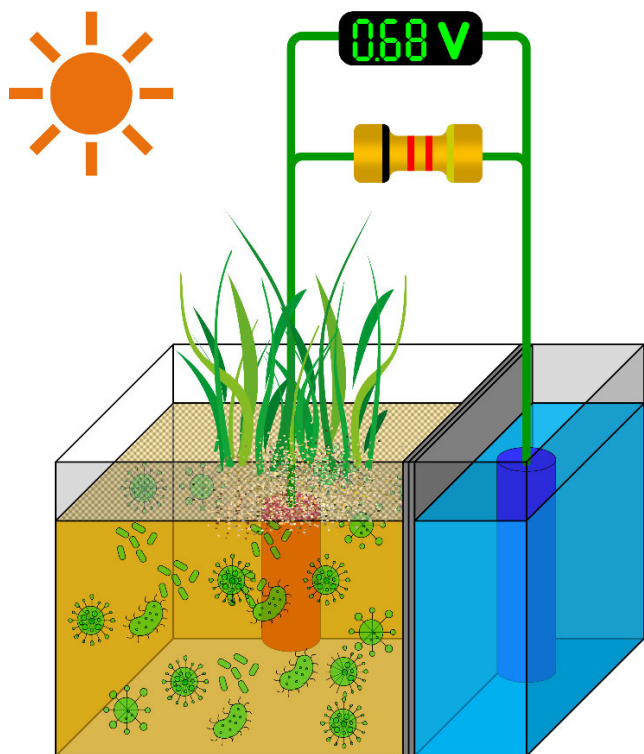

FIGURE 13. Photosynthetic MFC.

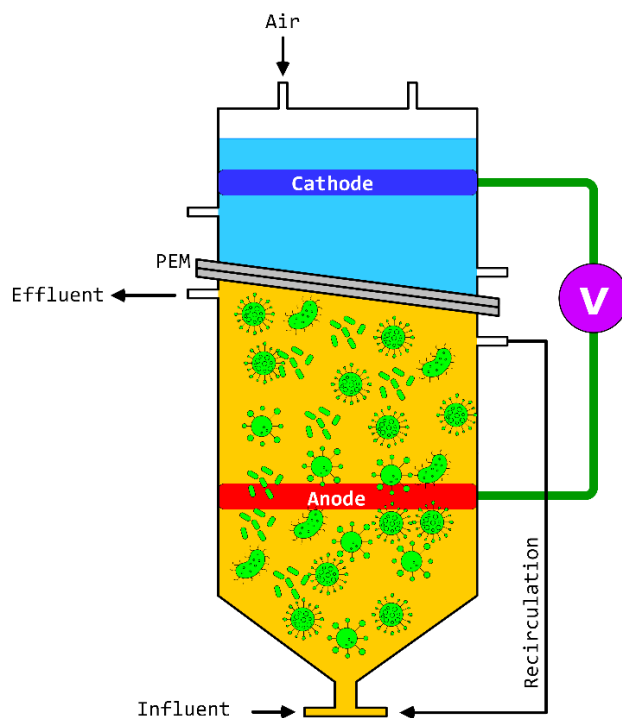

FIGURE 14. Up-Flow MFC.

H. SERIES-STACKED MFC

A series-stacked MFC was initially constructed by Oh et al. and B.E. Logan using the basic concept of the dry cell to multiply the total voltage in the system, as shown in Fig. 16. First, two single-chamber MFCs consisting of an anode, cathode, and reference electrode (Ag/AgCl) were constructed. The anode of the first cell was then connected to the cathode of the second cell using a graphite plate. Carbon paper and

Pt-coated carbon were used as materials for the anode and cathode, respectively [34].

I. OTHER TYPES OF MFC

1) HYDRAULICALLY STACKED MFC

J. An et al. introduced multiple single-chamber, membraneless MFCs stacked vertically to produce a high power density. First, they designed a cylindrical single-chamber MFC in

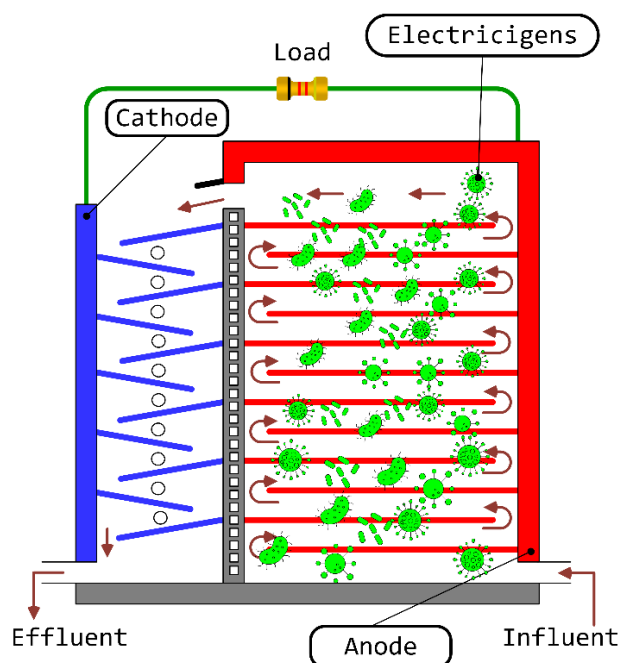

FIGURE 15. Multi-Criteria MFC.

which a graphite plate anode was placed at the bottom and covered by a rigid graphite plate as the bottom cap. The cathode was placed on top using graphite felt and exposed to air. Each compartment had an inlet for influents below the outlet for the effluent. Each cell was then connected vertically to form a stacked MFC. A copper wire was connected to the top cathode and bottom part of the anode (rigid graphite). The design is shown in Fig. 17 [71]. Winfield et al. tested seven hydraulically connected MFCs and concluded that this model is suitable for reducing the organic load and reacting to fluctuating flow rates [72]. However, the design complexity and high cost of this model are disadvantages.

2) MULTI-CRITERIA MFC (MCMFC)

Mathuriya et al. introduced another model called Multi-criteria MFC (MCMFC), as shown in Fig. 15. The main aim of this model is to remove the disinfection of clean water after treatment. This model consists of an anodic chamber with multiple anodes arranged in a horizontal position and biologically synthesized silver nanoparticle cathodes in a cathodic chamber placed slanted so that the liquid from the anode could flow down without any external equipment [36]. However, this model requires a pump to supply the influent to the MFC, which incurs extra costs for pump and energy consumption.

3) MULTI-ANODE CHAMBER MFC (MAC-MFC)

Generally, MFCs are designed using a single substrate type. However, to multiply power generation, Mathuriya et al. suggested multiple anodic chamber MFC (as shown in Fig. 18), which can treat more than one type of wastewater at a time.

They used three anodic chambers with three different types of wastewater connected to a single cathodic chamber with multiple cathodes. Nafion 117 was used as the PEM, and carbon paper and graphite plates were used as the anodes and cathodes [73].

4) MICROBIAL AUTO-FLOW MFC (MAFFC)

The two main processes required for scaling up an MFC include fluid mixing in the anodic chamber and aeration in the cathodic chamber for adequate power generation; however, this process requires additional power. To overcome this issue, Mathuriya et al. introduced an autoflow fuel cell, as shown in Fig. 19. It uses one anodic chamber in the middle of two cathodic chambers on the left and right, separated by the plaster-of-Paris sheet. Multiple stones coated with activated carbon were used as the anode electrode, and multiple cathode electrodes were placed in the cathodic chamber. This structure removes external power to pump the influent into the system [36], [74].

5) WETTED WALL MFC (WWWFC)

The wetted-wall MFC, as shown in Fig. 20, was constructed using two coaxial cylindrical glass tubes that separate the anodic and cathodic chambers. Carbon cloth was used as the anode and cathode, placed between the inner and outer tubes and inside the inner tube. The influent was pumped from the bottom to the anodic chamber, and the effluent flowed out of the cathodic chamber [75]. This model also requires an external pump to supply influent to the MFC. A notable advantage of this model is that the power density can be increased by increasing the flow rate. Unfortunately, oxygen reduction becomes the main limiting factor in generating higher power at a flow rate of more than 30mL/min. Table 5 summarizes the advantages and disadvantages of the different types of MFCs.

V. WORKING PRINCIPLES OF MFCs

The working principle of MFC is still not fully understood [76]. In an MFC, microbes oxidize the hydrocarbon substrate in an anodic chamber into protons (H^+), carbon dioxide (CO_2), and electrons (e^-). Carbon dioxide is released as a gas, and protons (H^+) move toward the opposite chamber across the PEM. Electrons were attracted to the electrode and transferred to the cathode through an external wire. Once the electron reaches the cathode, oxygen (O_2) from the surroundings consumes these electrons to combine with protons to form water (H_2O). This process continues until the substrate concentration in the anodic chamber is maintained at the optimal level and oxygen gas is available in the cathodic chamber [76], [78]. This process is illustrated in fig. 21.

A. BIOLOGICAL REACTIONS IN MFCs

The main difference between MFC and other fuel cells is the use of microorganisms to generate electricity. Fig.1 shows that research and development on MFCs has increased exponentially since 2019. The main reason for the increased interest in this field is the introduction of exoelectrogenic bacteria

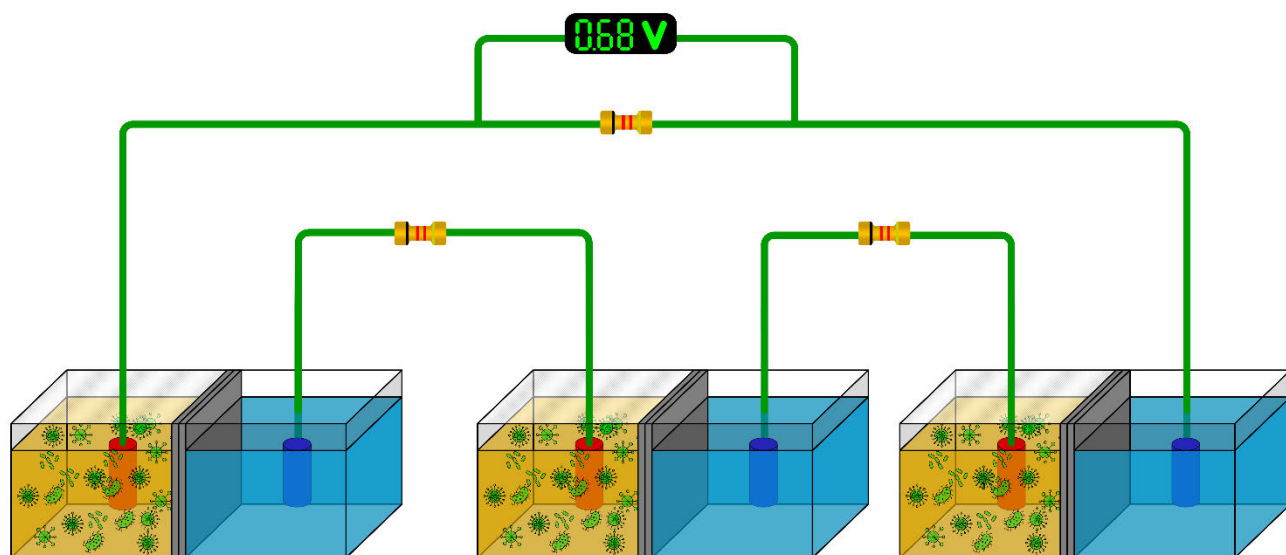

FIGURE 16. Series-Stacked MFC.

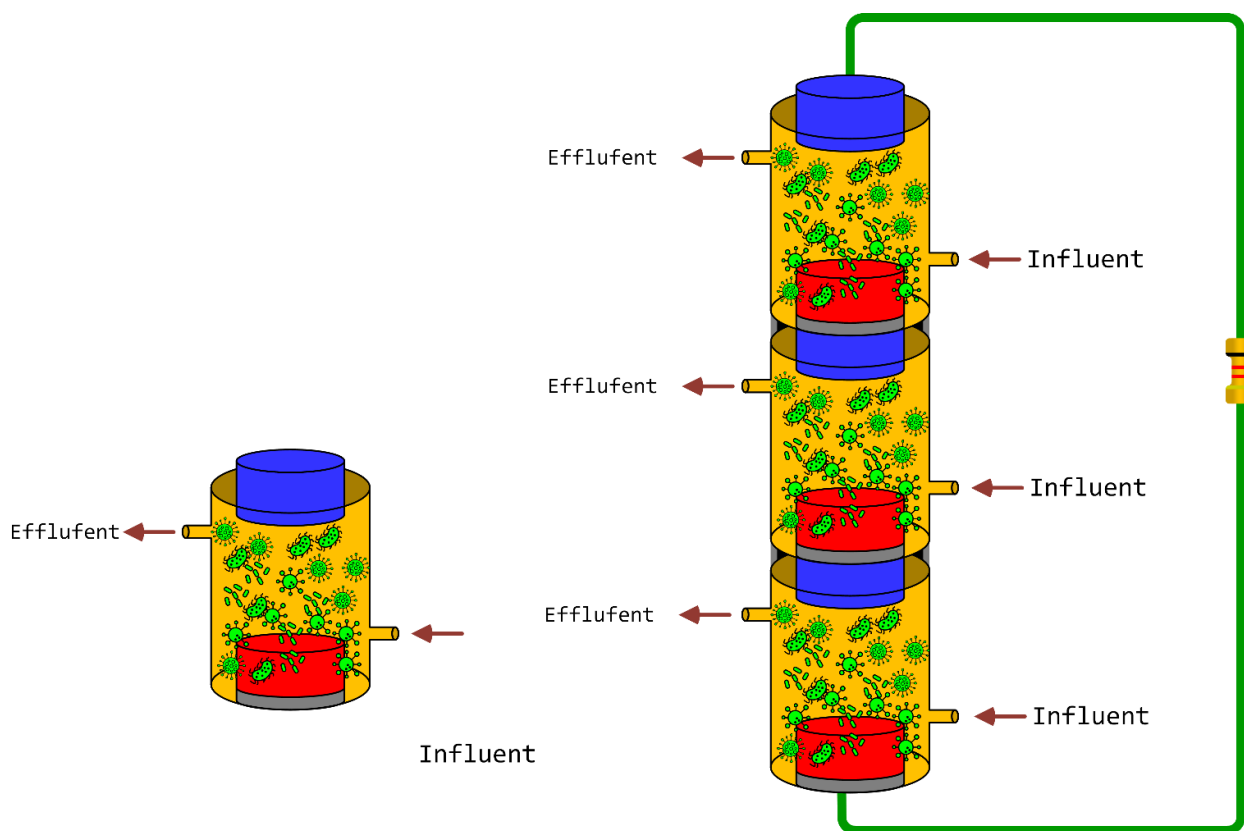

FIGURE 17. Hydraulically Stacked MFC.

into MFC technology [38]. *Shewanella* and *Geobacter* are examples of electric bacteria that release or accept electrons at different potentials without a mediator [79]. These exoelectrogenic bacteria transfer electrons, either directly or

indirectly, to the anode. Direct transfer occurs through a physical connection called nanowires, and indirect transfer occurs through electron-shuttling molecules [80]. Therefore, this type of bacteria can generate a high current in MFC.

B. CHEMICAL REACTIONS IN MFCS

Glucose, Acetate, and Sucrose are the most used primary substrates to initiate an oxidation process in the anodic chamber [81]. The chemical equations for the oxidation process in anodic chambers are as follow [82], [82]:

Glucose:

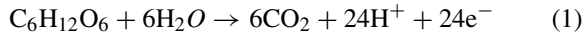

Acetate:

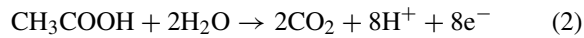

Sucrose:

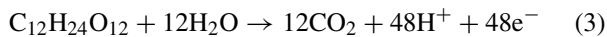

Formate:

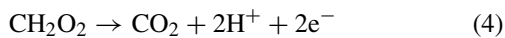

Propionate:

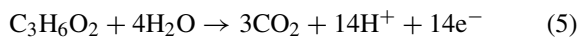

Ethanol:

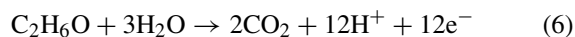

Equations (1)–(6) show that the number of moles of electrons and protons (H^+) produced by the oxidation reaction in the anodic chamber are always the same. Thus, if the number of electrons and protons produced in the anodic chamber is fully moved to the cathode and cathodic chambers, respectively, without any losses, the same number of electrons and protons will be used by oxygen to produce water molecules, according to the following equation:

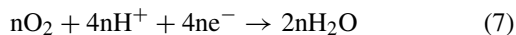

C. ELECTRICAL PROPERTIES OF MFCS

Voltage and current are two significant quantities that play a prominent role in any electric circuit. The work done to move a positive charge from the low-potential point (negatively charged) to the high-potential point (positively charged) was defined as the voltage. In comparison, the rate of electron flow through a point in a closed circuit is defined as the current. The directions of the current and electrons are opposite [84]. Electrons flow from the negatively charged point to the positively charged end [85].

There are three types of generators used to produce current in an electrical circuit: (a) chemical-based generators, (b) electromagnetic generators, and (c) thermoelectric generators. The MFC uses chemicals to generate voltage and current. Generally, an electrolyte is oxidized in a chemical-based generator to produce both negative and positive ions. When two metal plates are dipped into this electrolyte, the positive ion is attracted to one metal and the negative ions are attracted to another metal. If these two metals are connected using an external resistor, current is generated by moving electrons and ions [84].

The electric current (I) is the number of electrons passing through a certain point in an electric circuit for one second from the positive terminal to the negative terminal [86]. The anode is a high-potential area that is rich in electrons. Therefore, the cathode becomes a positively charged area with fewer electrons and attracts more electrons, which carry a negative charge. Therefore, the number of electrons flowing from the anode to the cathode determines the amount of electric current produced in the circuit. When the number of electrons in the anode increases, the value of the electrical current produced in the circuit increases.

1 Coulomb of Charge contains 6.242×10^{18} electrons.

$$1 \text{ C} = 6.242 \times 10^{18} \text{ Electrons} \quad (8)$$

The electric current is described as the rate of change of charge [86]. So,

$$\text{Electric Current, } I = \text{Charge (Q) / time (T)} \quad (9)$$

Therefore, referring to (9) and (10), we can conclude that

$$1 \text{ Ampere} = 1 \text{ Coulomb/second} \quad (9)$$

$$1 \text{ Ampere} = 6.242 \times 10^{18} \text{ electron/second} \quad (10)$$

$$1 \text{ electron/second} = 1.602 \times 10^{-19} \text{ A} \quad (11)$$

Equation (12) indicates that when one electron flows in a circuit for one second, a current of $1.602 \times 10^{-19} \text{ A}$ is generated. If n electrons flow in a circuit for one second, then a current of $1.602 \times n \times 10^{-19} \text{ A}$ will be produced.

Thus, if N_e represents the number of electrons flowing in a circuit and Q_e is the charge of an electron (1.602×10^{-19}), then the general equation to show the number of electrons flowing in t s and the total current generated in an electrical circuit can be written as:

$$I = \frac{N_e Q_e}{t} \quad (12)$$

Equation (12) shows that the current is proportional to the number of electrons flowing in the circuit ($I \propto N_e$).

1) ELECTRON AND PROTON TRANSFER MECHANISM IN SINGLE CELL MFC

The current generation of MFCs depend on the number of electrons produced by the oxidation reaction in the anodic chamber. The substrate concentration, pH, and temperature are the three main factors that influence the reaction rate of the anodic chamber (other factors are negligible at this stage). At high substrate concentrations (pH between 7.0–9.0, and temperature of 25–35 °C), the oxidation process in the anodic chamber can produce a high volume of electrons and protons. These electrons are attracted to the anode and then move to the cathode, generating an electric current. Simultaneously, the protons moved to the cathodic chamber across the PEM. The electrons and protons accumulated in the cathodic chamber react with oxygen gas to produce water molecules. If these parameters (concentration, pH, and temperature) are maintained at optimal levels, the redox process will continuously generate an electric current in the circuit. Unfortunately, if any of these parameters are changed or

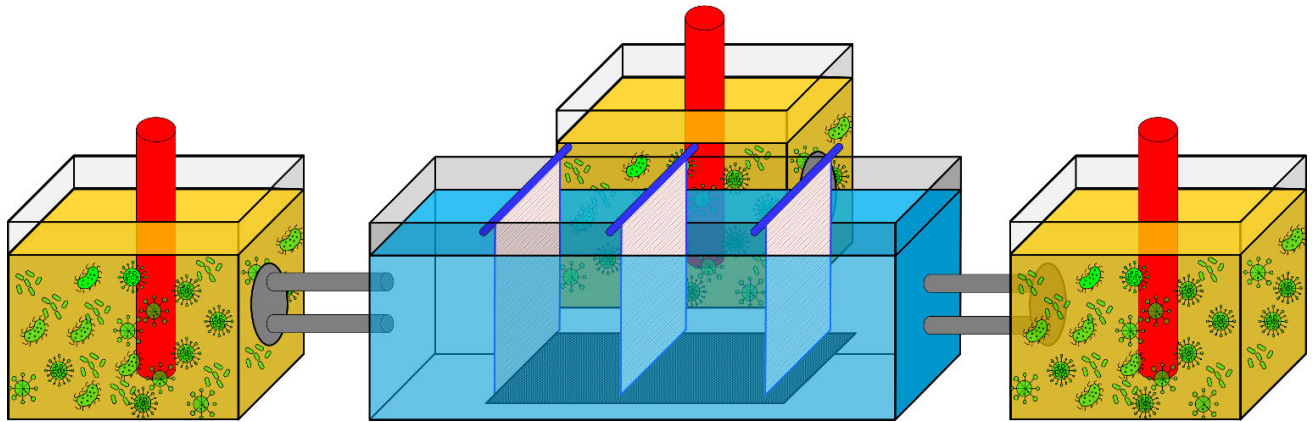

FIGURE 18. Multi-Anode Chamber MFC.

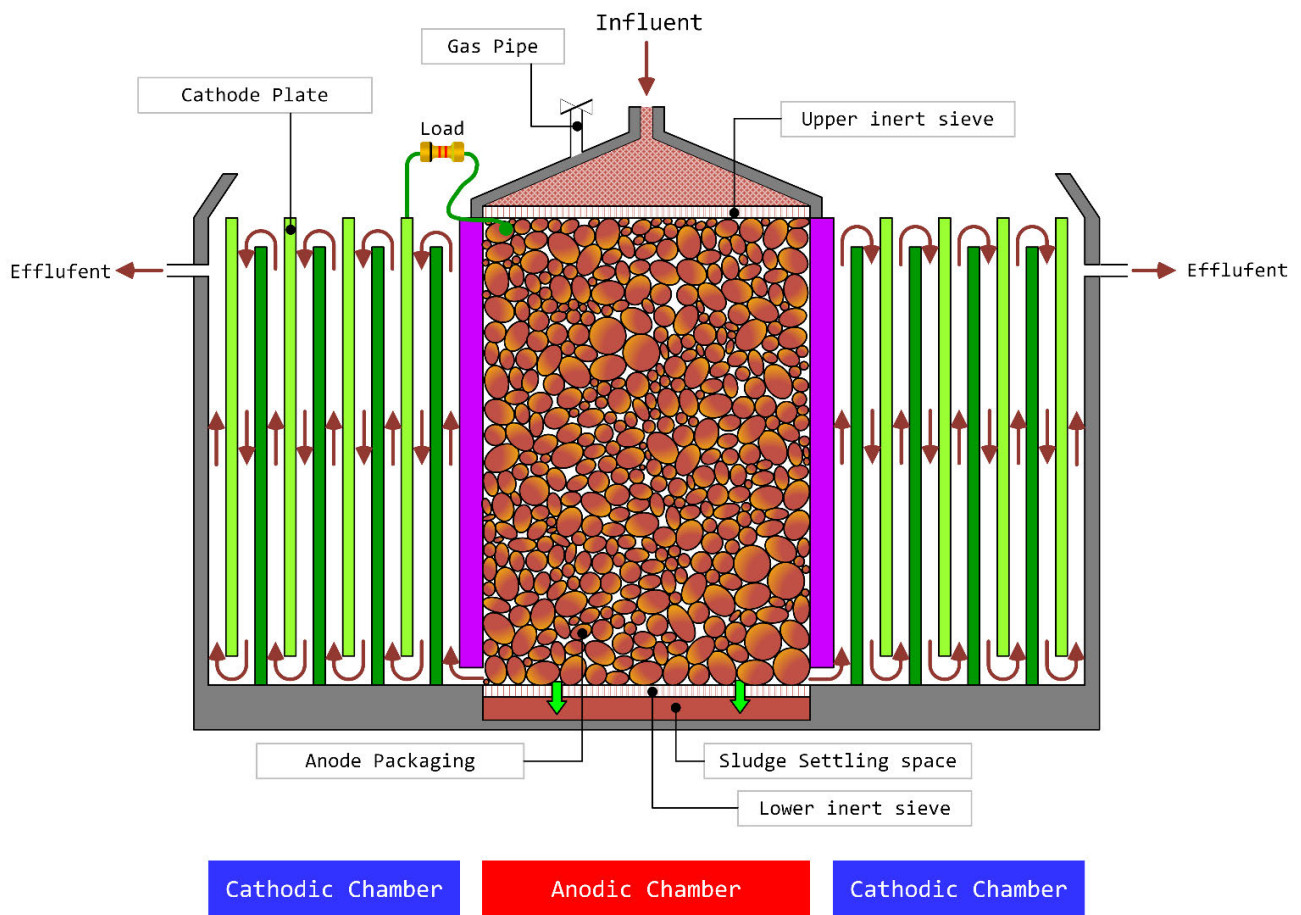

FIGURE 19. Microbial Auto-Flow Fuel Cell.

dropped, the number of electrons and protons produced in the anodic chamber is reduced. This situation affects current generation in the circuit, and a voltage drop occurs until the system malfunctions.

2) ELECTRON AND PROTON TRANSFER MECHANISM IN SERIES-STACKED MFC

Electrons and protons are not transferred within their compounds when connected in series. Fig. 22 shows three air-

cathode MFCs connected in series to explain this situation. The anode of MFC-1 (A-1) was connected to the cathode of MFC-3 (C-3). Similarly, the anode from MFC-2 (A-2) was connected to C-1, and the anode from MFC-3 (A-3) was connected to C-2. In the initial stage, the parameters (concentration, temperature, and pH) for all three MFCs were maintained at a common point. Thus, the number of protons and electrons (N number of protons and electrons) produced in all three MFCs was the same. Therefore, the N number of

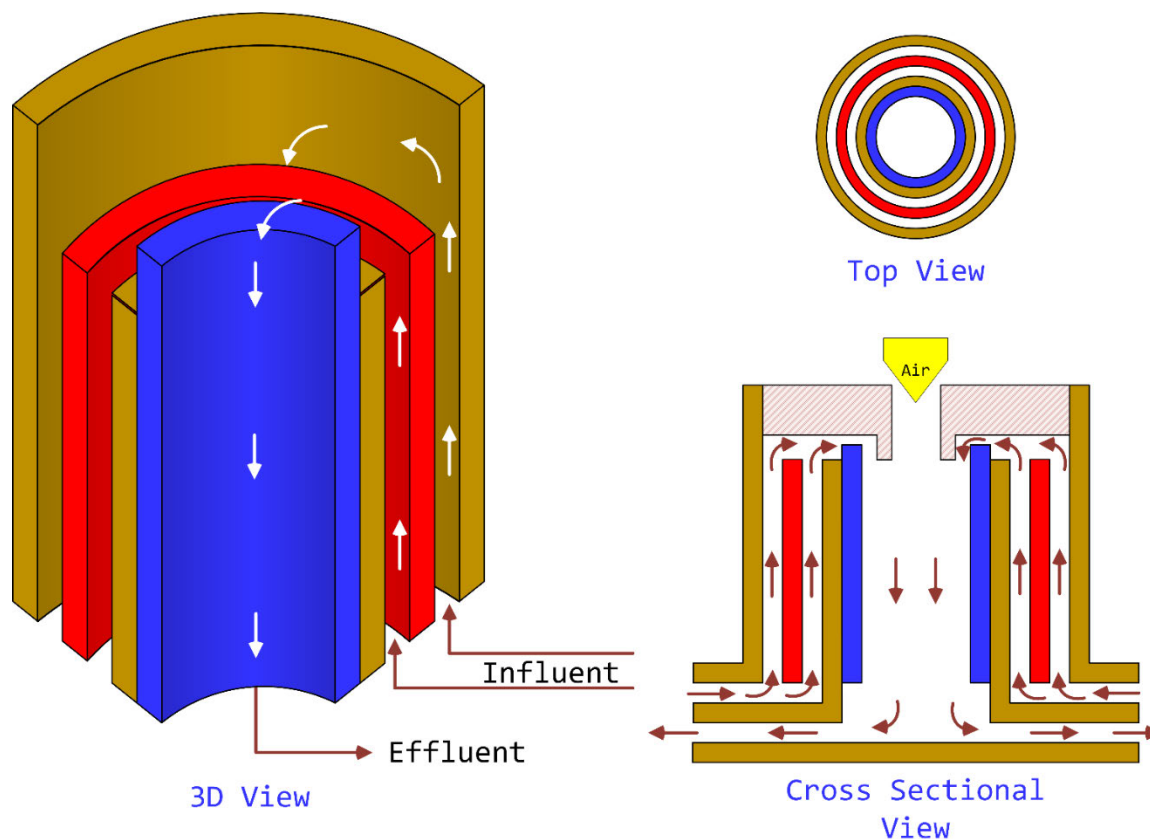

FIGURE 20. Wetted-Wall MFC.

electrons from A-1 and the N number of protons from MFC-3 move to C-3.

All of these particles are fully reduced by oxygen to produce water molecules, and cathode C-3 becomes empty to receive new electrons and protons. If the chemical parameters are the same in all three MFCs, there is no issue because the same number of electrons and protons are accumulated in C-1 and C-2 to produce water by the reduction process. However, the system becomes imbalanced when any of the reactor's chemical reactions become sluggish owing to the low concentration or invalid pH and temperature values.

For example, the substrate in MFC-2 had a lower concentration than the other two MFCs. Therefore, the number of electrons and protons produced in MFC-2 was less than those in MFC-1 and MFC-3. Therefore, the number of electrons transferred to C-1 (from A2) is less than the number of protons received by C-1 (from MFC-1). When the number of protons exceeds the number of electrons, the reduction process uses the lowest number of particles to produce water. In this situation, C-1 had an excess of protons. Simultaneously, fewer protons from MFC-2 are transferred to C-2 through the PEM, while C-2 receives more electrons from A-3, resulting in excess electrons in C-2 after reduction. The accumulation of electrons in C-2 makes it a negatively charged electrode and prevents the attraction of more electrons from A-3. At one

point, C-2 becomes the anode and A-3 becomes the cathode. Therefore, voltage reversal occurred between C-2 and A-3, giving the system a negative voltage. If this situation is not rectified and controlled at the initial stage, it will damage the electrodes and the system will fail. The same issue can occur in MFC with different pH and temperature values. Therefore, to avoid this issue, all parameters in all MFCs should be maintained at the same level. Unfortunately, maintaining each reactor with a standard operational parameter is not an easy task for MFCs as they consist of complex mixtures.

VI. VOLTAGE REVERSAL IN STACKED MFC

The main drawback of MFC is that the amount of power generated by a single cell is ultra-low, making it challenging to boost it through power electronic circuits [4], [87]. Although many attempts have been made to increase MFCs power generation, stacking up by combining two or more cells in series or parallel has been suggested as an efficient and economical method to increase the output power [88], [89]. However, the Voltage Reversal (VR) becomes another issue in this type of MFCs, which gives a 'zero' resultant voltage or current.

The voltage reversal phenomenon has become a critical issue in series-stacked MFC, even though it uses the same concept as in series solar and battery cells. In general, solar

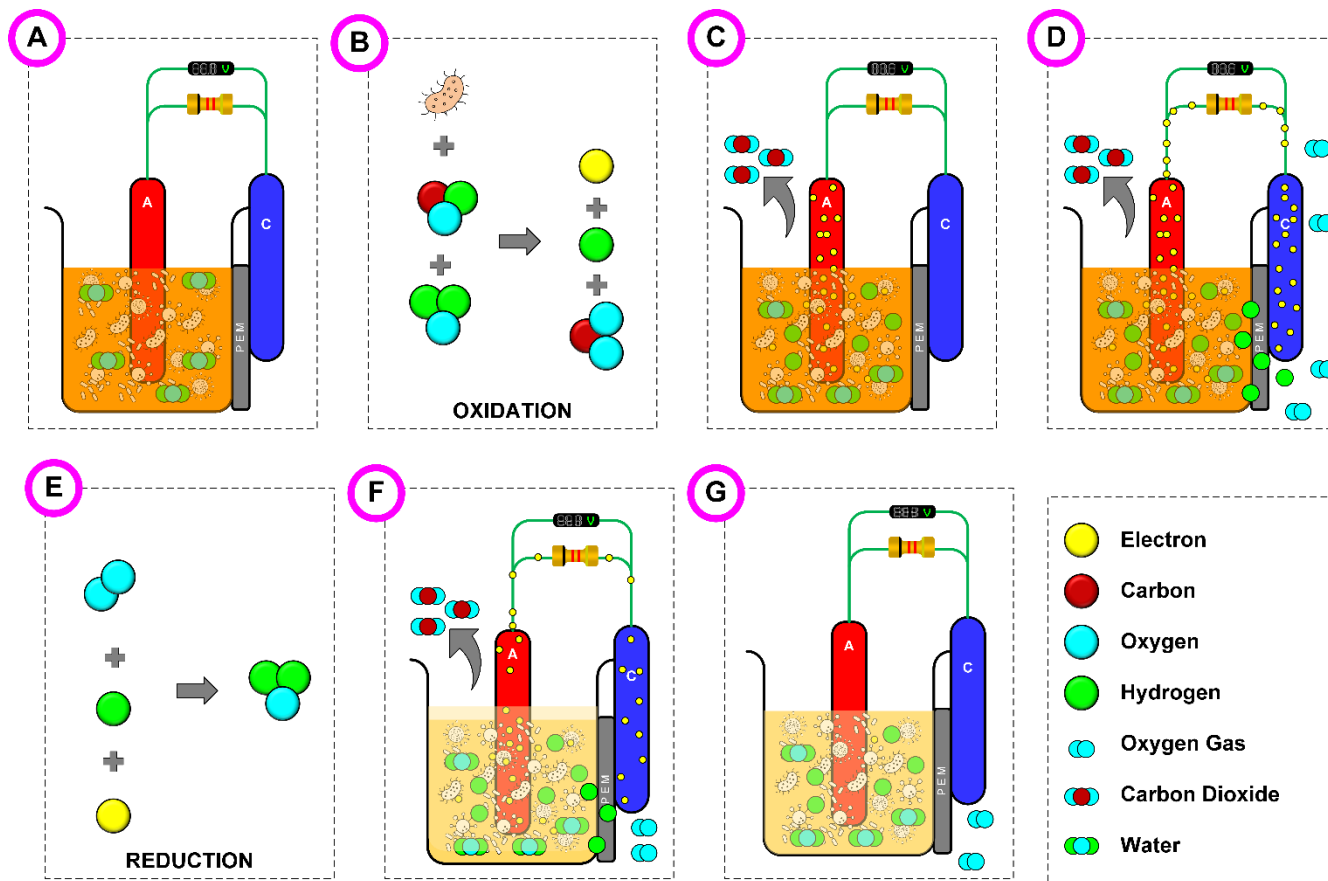

(A) An Air-cathode MFC consists of an Anodic chamber, anode, proton exchange membrane, and external wire with a resistor (B). Microbes inside the anodic chamber released electrons to oxidize the hydrocarbon substrate into Carbon dioxide gas, ion hydrogen (proton), and electrons (C). The electrons are move to the anode electrode and form biofilm (D). Ion Hydrogens (proton) are moving to cathodic chamber across the PEM. The electron from the anode moves to the cathode through an external wire and resistor to generate electricity (E). Oxygen gas from air uses the electrons accumulated at the cathode to bond with protons to form water (F). When the process is continuously run, the concentration of the substrates is reduced. This will reduce the chemical reaction in the anodic chamber and slow down the process (G). Finally, when the substrate concentration in the anodic chamber is too low, the process will stop, and no current is generated.

FIGURE 21. Basic working principles of Air-Cathode MFC.

electrical connections entirely use a solid electrical conductor, where only electrons are involved as charge carriers between the anode and the cathode. Unfortunately, electrons and protons are involved in the current generation of MFCs. The substrate concentration mainly determines the number of electrons and protons produced in the MFC. Therefore, an imbalanced substrate concentration will produce an imbalanced electron and proton production, affecting the MFC’s total power generation.

A. VOLTAGE REVERSAL CONTROL MECHANISM

A stacked MFC produces voltage reversal which can reduce the total power generation of the system [34], [87]. This phenomenon occurs when one of the cells in the stacked system achieves higher or lower voltages than the other cells [34] and was introduced as cell reversal by Aelterman et al. [32] in 2006. They stacked six identical MFCs in series to generate 258W/m³ volumetric power with a maximum cell voltage of 2.02V. However, some MFCs showed reversed polarity

due to increased anode potential and excessive current. The following year, Oh and Logan [34] tested a two-chamber air-cathode MFC in series using 0.1 Molar acetate in the cathodic chamber in fed-batch mode. They observed that voltage reversal occurred at the final stage of the fed-batch cycle, caused by fuel starvation and not by the bacteria used. Therefore, they suggested the following points to control voltage reversal in the MFC:

- voltage reversal must be eliminated to avoid short circuits in stacked MFC
- continuous fuel supply is required to reduce voltage reversal
- avoid low substrate conditions through the continuous operation of stacked MFC and
- maintain the system’s current density at a low value.

Subsequently, many studies have been conducted to control voltage reversal in MFC by manipulating their chemical, biological, physical, and electronic properties. Table 6 shows

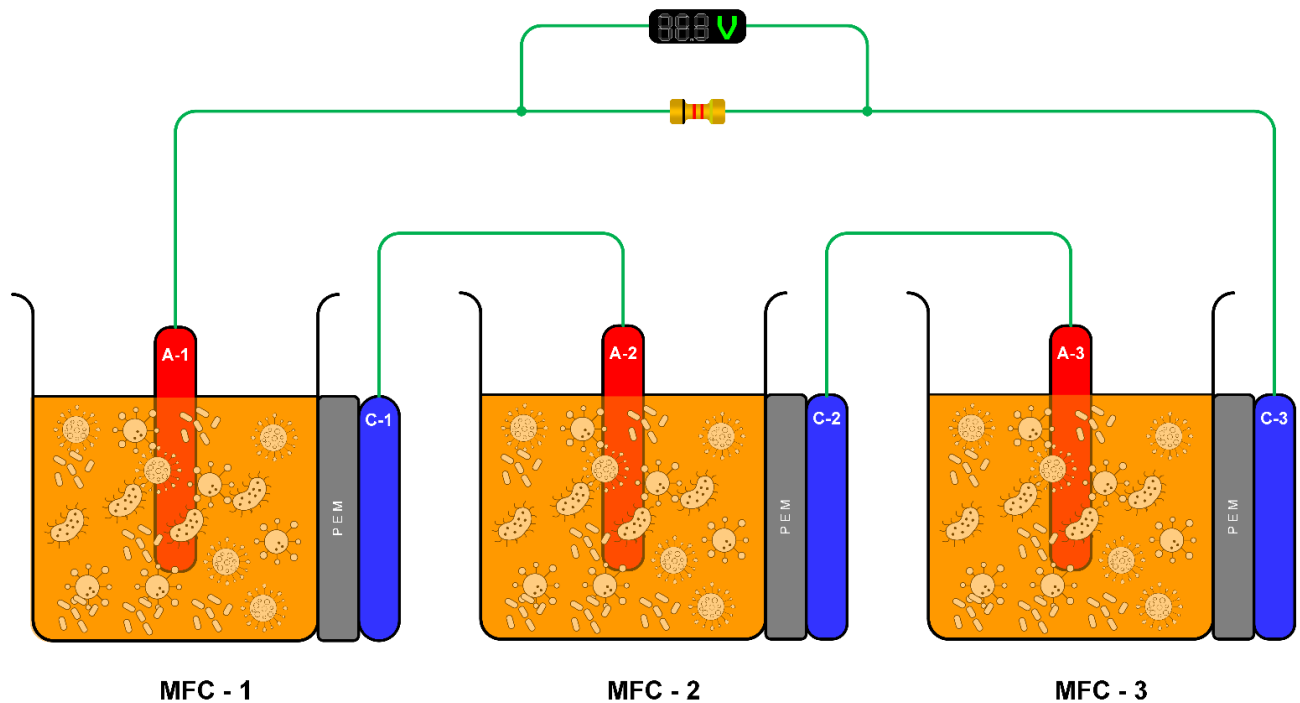

FIGURE 22. Three MFCs connected in series.

TABLE 6. Notable Research that discussed Voltage Reversal in MFC.

| Year | Suggestion or Conclusion by the researchers/author | Reference |
|------|--|-----------|
| 2013 | Authors claim that VR only happens temporarily and recovers itself due to biofilm capacitance without any external manipulation. | [90] |
| 2014 | This paper claims that the voltage reversal is caused by a power overshoot. So, it suggested combining MFCs in series and parallel to reduce power overshoot and VR. | [91] |
| 2015 | No VR is observed in five identical series-stacked MFC cells with variant substrate concentration | [31] |
| 2015 | Authors used Sediment Microbial Fuel Cells connected in series. The Voltage Reversal has been reduced by adjusting the internal resistance of each MFCs close to a few Ohms. | [92] |
| 2015 | Author used a variable resistor to control assistance current to resolve voltage reversal in series-connected MFCs | [93] |
| 2015 | Authors conclude that Voltage reversal only happens when current density > critical current density, with the VR controlled using a threshold resistor. | [94] |
| 2017 | This paper suggested using an adjustable resistor to control the current production in series-connected MFC. | [95] |
| 2018 | This paper claims a continuous VR can cause spoil the biofilm and lead to the malfunction of the MFC. | [28] |
| 2018 | Suggests Voltage Balancing Circuit (Switching Capacitor) to control the Voltage Reversal | [30] |

the notable literature that has discussed MFC voltage reversal phenomena since 2013.

Although many studies have discussed methods to control voltage reversal in MFC, only a few attempts have been made to control it using the electronics approach.

1) VR CONTROL USING RELAY SWITCHES AND CAPACITOR
Kim et al. [96] used a microcontroller to control relay switches connected to a couple of capacitors to eliminate voltage reversal in a stacked MFC. They connected four MFCs in parallel with supercapacitors, which were charged

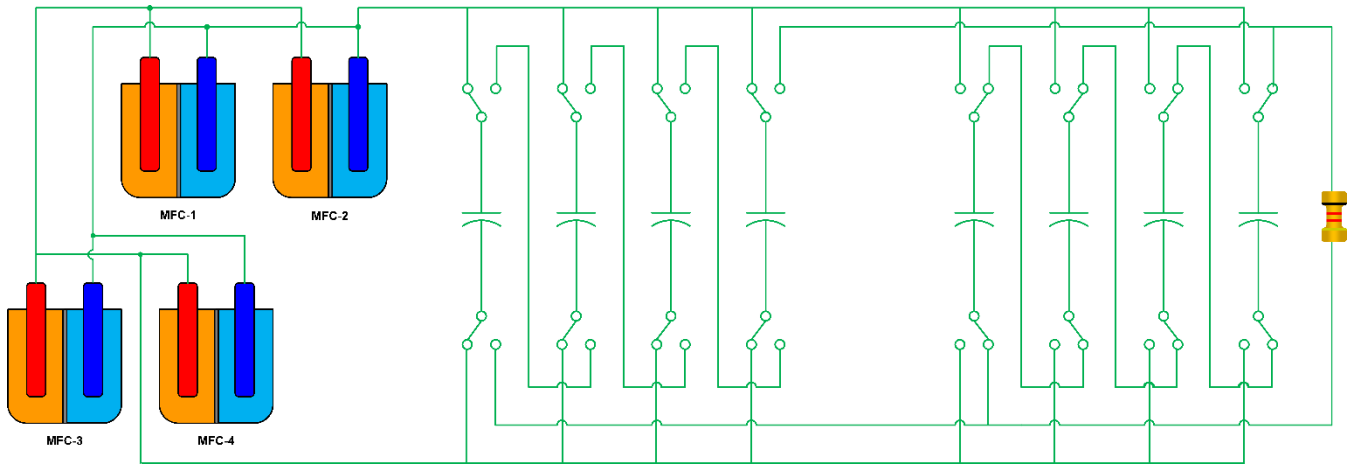

FIGURE 23. VR Control using relay-switched circuit.

in parallel and discharged serially every second. The maximum voltage recorded was 2.5 V with eight capacitors, which drops below 0.5V with less than 2mA of current. No current reversal issue was discussed in this work, even though the literature shows that parallel-stacked MFCs generate current reversal instead of voltage reversal. Although the author claims negligible energy loss in the system with 67% Coulombic efficiency, the external resistance is expected to contribute to the energy losses. Fig. 23 illustrates this control module.

2) VR CONTROL USING DIODES

Zhu et al. connected three MFCs in series and tested their performance without diodes, with forward-bias diodes, and reverse-bias diodes. They investigated the effect of the diode in controlling the voltage reversal, as shown in Fig.24. The stacked system without a diode generates a maximum of 0.8V with a 500-ohm resistor for 17 hours compared to 1.06V if connected separately. This result shows that there is about a 0.26 voltage drop due to VR. When the diodes are forward-biased, the voltage of one MFC is reversed and the total voltage of the stacked MFC decreases to 0.35V, caused by the resistance and voltage reversal of the diode. When diodes are connected in reverse bias, voltage reversal still occurs in one MFC, whereas the other two MFCs generate 0.75V, suggesting that voltage reversal will occur with and without diodes. In addition, the diodes generate extra voltage drops in the stacked MFC. If the system can intelligently manipulate forward and reverse bias, it may help reduce the voltage reversal phenomenon in a stacked MFC [77].

3) VR CONTROL USING VOLTAGE BALANCING CIRCUIT

Khaled et al. used voltage-balancing circuits to control VR in a two-series-stacked MFC. A parallel capacitor is connected to the individual MFC (two units) and controlled by a single-pole double thread (SPDT) switch through an oscillator.

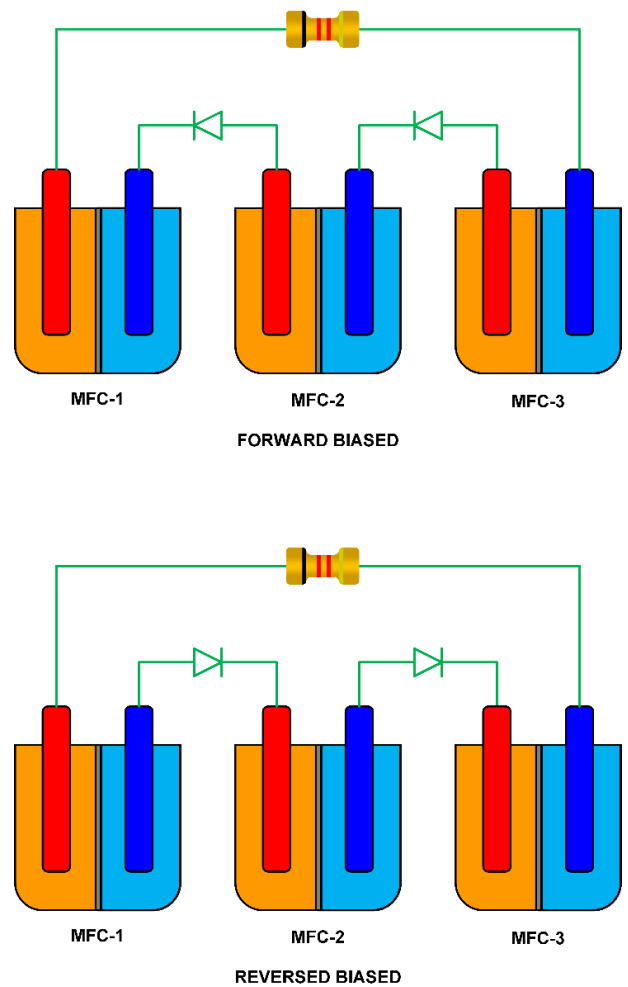

FIGURE 24. VR Control using forward- and reverse-biased diode.

The circuit performance was low at low frequencies ($f = 1$ Hz), but at high frequencies ($f = 10$ kHz), the efficiency increased to 90%. However, conduction, internal resistance,

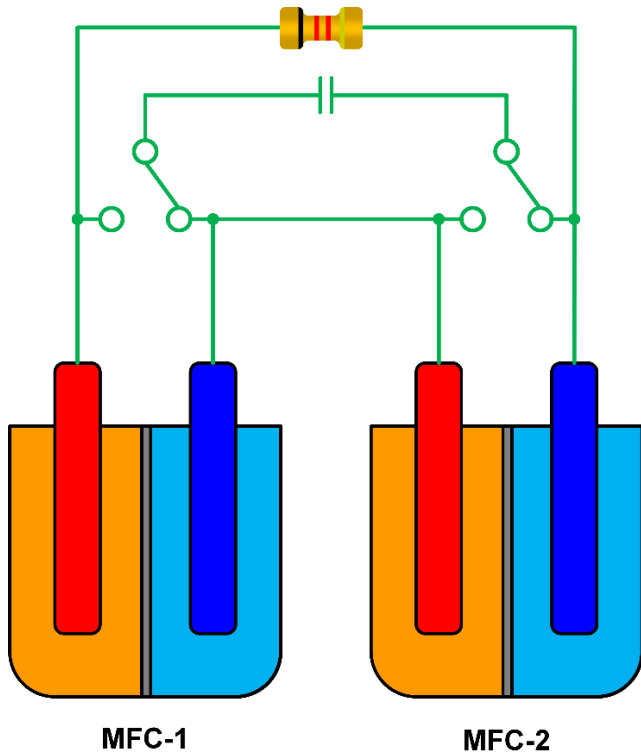

FIGURE 25. VR Control using Voltage Balancing Circuit.

and switching losses occur in the system. This system was tested only for a two-series stacked MFC. Multiple-stacked MFC can generate considerable losses in the system with an increasing number of switches [31]. An illustration of the controller is shown in Fig. 25.

4) VR CONTROL USING THRESHOLD RESISTOR

J. An et al. suggested that voltage reversal could be eliminated if the stacked MFCs current was maintained below the critical current density. To achieve this, the author used a threshold resistor between the two individual cells, as shown in Fig. 26. The threshold resistor can control the voltage reversal in the system. However, it generates energy loss with 91mV of a voltage drop of it [92].

5) VR CONTROL USING ASSISTANCE CURRENT

Kim et al. [94] applied an external current to the unit cells to eliminate the voltage reversal in the stacked system, as shown in Fig. 27. In a 3-series stacked MFC, they found one unit with a lower current density and defined it as a weak cell that generated voltage reversal. Thus, they introduced another electrode inside the weak cell, connected it to the anode, and supplied an assistance current to balance the power. Unfortunately, even though the voltage of the weak cell is increased, the overall stacked voltage still exhibits a negative value. Subsequently, another electrode was added with the same aim, but it regenerated the voltage reversal in another cell. Finally, they introduced an external resistance between the assistance electrode and cell electrode to control this

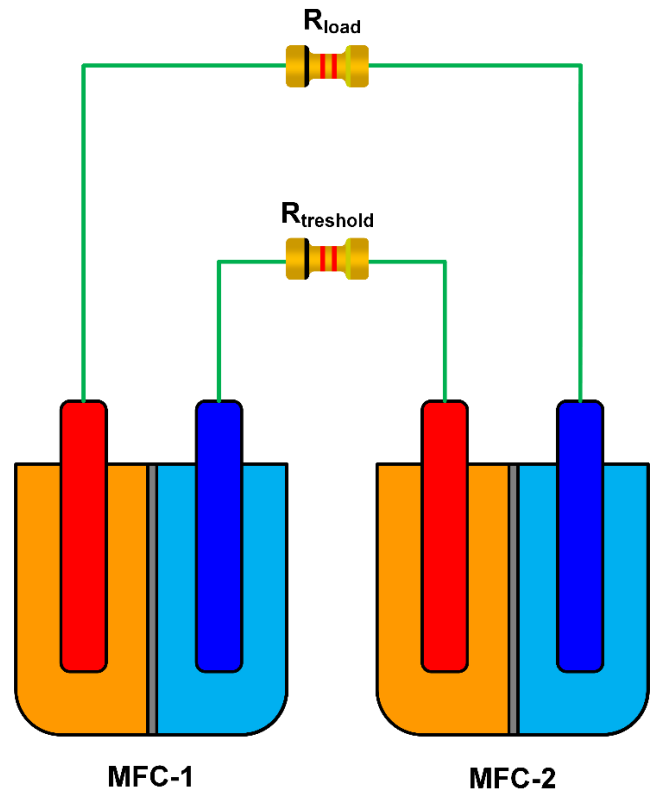

FIGURE 26. VR control using threshold resistor.

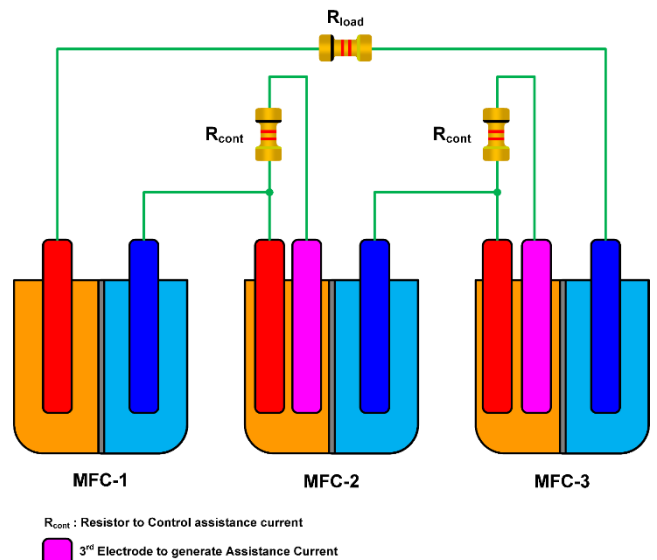

FIGURE 27. VR Control using Assistance Current.

phenomenon. Unfortunately, this method fails to produce balanced and stable power generation owing to the regeneration of VR in different units.

6) VR CONTROL USING CURRENT CONTROLLING RESISTOR

Kim et al. [97] suggested a multiple-membrane electrode MFC to eliminate voltage reversal. This concept uses the assistance-current method but is improved with an additional manipulating resistor. The authors constructed two 4-MFCs

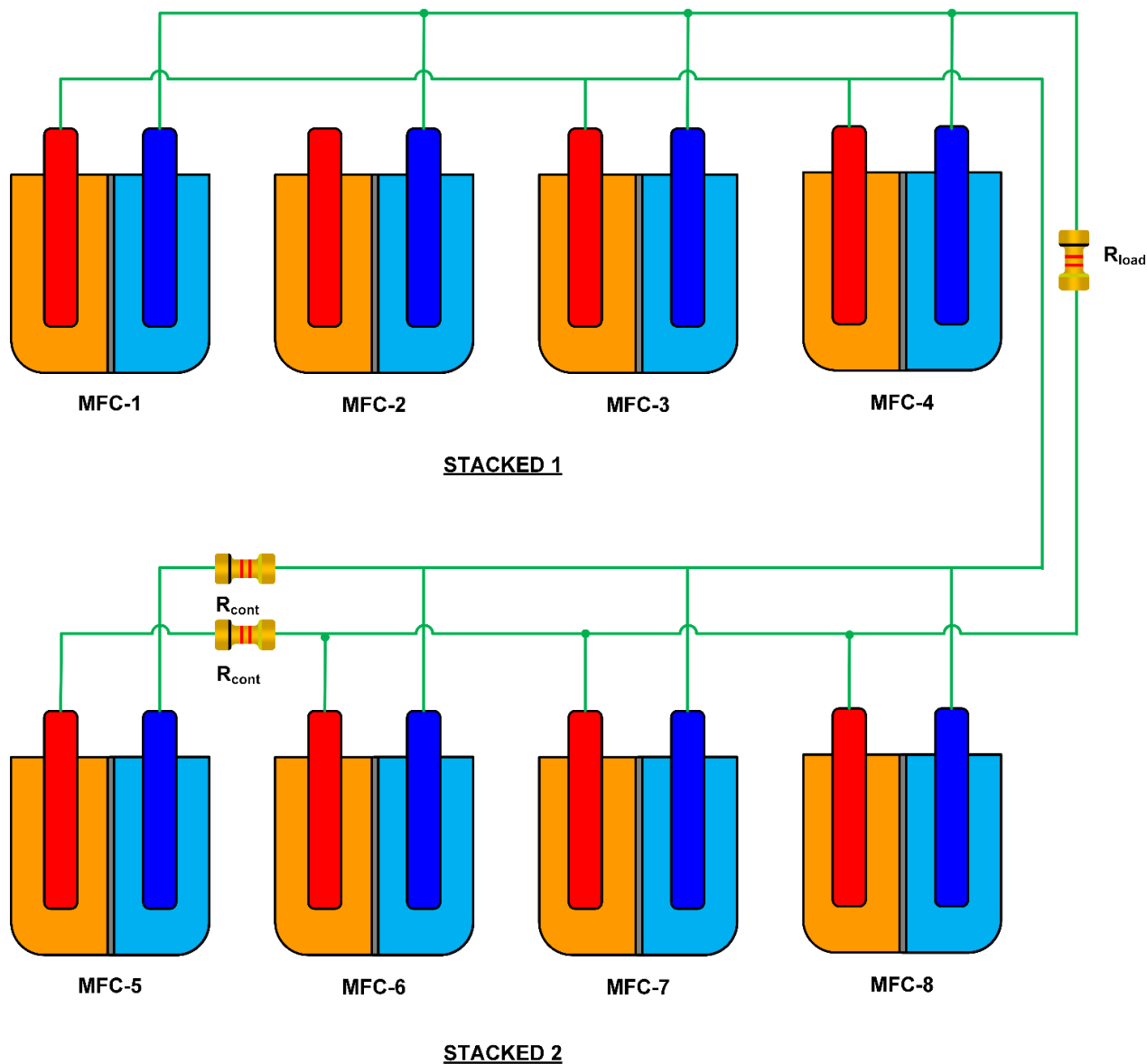

FIGURE 28. VR Control Using Current Control Resistor.

in a parallel stack and connected them serially with threshold resistors to eliminate VR, as shown in Fig. 28.

VR occurs in the system for low resistance values. Therefore, voltage reversal can be eliminated by adjusting the internal resistance to control the internal current. However, from the author’s perspective, this control method cannot be clearly explained using manual or automatic systems. Moreover, a manual system to control the resistance will be a burden if the operation takes a long time.

B. CRITICAL REVIEW OF VR CONTROL METHOD IN CURRENT LITERATURE

Current literature still shows a lack of solid design to control or eliminate voltage reversal in stacked MFC. The main issue in serially connected MFC is the occurrence of reversal

polarity in one or more unit cells of the system. Therefore, an electronic control method is required to eliminate VR in stacked MFC. The control methods discussed in the previous sections (VI-B-2 to 6) are good examples of electronically controlled MFC systems. However, using passive electronic components, such as diodes, resistors, and capacitors, generates more power losses in the system. Therefore, the system design must have fewer passive components.

A capacitor using a microcontroller to control the switches to charge and discharge was a good attempt by Kim et al. However, the numerous switches used in this design can result in high power losses in the system. One similarity in all the control methods is that they focus only on the output parameter, which is the voltage and power generation in the system.

However, the author strongly agrees (discussed in sections IV- A) that the main reason for VR in series stacked MFC is non-identical input parameters such as substrate concentration, temperature, and pH value of the individual cells. Therefore, balancing the input parameters is a primary concern in eliminating VR in the stacked MFC. Therefore, an artificial automatic control system is required to maintain identical input parameters in a stacked MFC. For this purpose, the author recommends using a low-cost microcontroller with multiple input sensors to measure, detect, and modify the input parameters of each cell in the stacked MFC.

VII. CHALLENGES AND FUTURE DIRECTION OF THE MFC

A report from Statistics MRC [98] announces that the MFC market is expected to reach \$22.38 Million by 2026, which accounts for 11.2% growth in ten years, with biosensors, wastewater treatment, and education industries contributing significant factors for this growth. Unfortunately, low-power generation and high-cost materials remain significant challenges for the growth of MFCs in the future. In recent years, research on MFC has shifted slightly toward low-cost designs using low-cost membranes, membrane-less reactors, and air-cathode MFCs [99]. However, apart from the material cost, operational cost is also becoming a significant issue in scaling up MFCs. To reduce the operational cost, Tommasi et al. [100] analyzed the energy sustainability of various MFCs and suggested that a sediment MFC (Benthic MFC) is suitable as a low-cost MFC.

Although power generation in MFC is very low, they can still be used for low-power gadgets such as mobile phones, biosensors, and laptops. Furthermore, the application of MFC in the human body to power biomedical devices such as pacemakers could be a new technology in the future [28].

Currently, many industries are interested in the development of large-scale MFC systems. However, stacking several MFCs in series or parallel connections is more effective in an electronic control system. Thus, the involvement of electrical engineers is crucial for developing a power management system for MFC to generate an adequate and stable power output. However, a new design of integrated circuits (ICs) and electronic control units will open a new path for advancing MFC design to solve global energy needs [101], [102].

VIII. CONCLUSION

Despite many challenges, MFCs have considerable advantages in replacing the current electrical energy generation for various applications. MFCs are the only technology that can remove pollutants while producing electrical energy directly from chemical energy. The drastic change in research and development of MFC in the last 20 years shows the growing popularity of this technology among researchers. Removal of pollutants while generating electricity, direct chemical to electrical energy, performance under mild conditions, easy customization, no sludge aeration, lower sludge treatment, self-regeneration of microorganisms, and water reclamation are some advantages of MFC. At the same time, some critical

issues in MFC, such as ultra-low power generation, high-cost materials, high internal resistance, membrane fouling, electrochemical limitations, and mass transport limitations, prevent it from becoming the primary source of power generation.

Three main chemical properties influence MFC performance: substrate concentration, temperature, and pH value. At the same time, modifying the reactor design was found to improve MFC. MFCs use a redox reaction to produce electrons and protons and transfer them from the anodic chamber to the cathodic chamber to generate current and voltage. However, a single cell can only generate a maximum of 1.1 V, well below the required voltage of many electronic appliances. An attempt to stack MFCs in series or parallel is a solution to increasing the total voltage and current; however, voltage reversal occurs in the system and reduces the total voltage and current.

Fuel starvation and high current density are the primary reasons for the VR of stacked MFCs. Some literature reviews have deduced that maintaining each cell's chemical properties (substrate concentration, temperature, and pH) at a standard level will prevent VR in stacked MFC. The main issue in stacked MFC (series-stacked) is that the electrons and protons transferred to the cathodic chamber are not from the same cells. Therefore, when the chemical properties in each cell are not the same, the number of electrons and protons arriving at the cathodic chamber may vary, possibly generating excess electrons and protons in the cathodic chamber and producing voltage reversal.

Much research has been conducted in the past ten years to prevent VR using electronic control circuits, power management systems (PMS), and voltage boosting. However, most designs use resistors and diodes to introduce more power loss in the system. Using capacitors and transistors with a microcontroller could be a better solution for preventing VR in a series of stacked MFC. Solving the VR issue in a series of stacked MFC using a comprehensive electronic control unit may become a significant factor in boosting this technology in the commercial world. In addition, reducing material and operational costs will promote future implementation of MFCs as they have a wide range of applications as future power sources. Therefore, continuous research and development to improve this technology is critical for the future of global energy.

REFERENCES

- [1] A. Qazi, F. Hussain, N. A. Rahim, G. Hardaker, D. Alghazzawi, K. Shaban, and K. Haruna, "Towards sustainable energy: A systematic review of renewable energy sources, technologies, and public opinions," *IEEE Access*, vol. 7, pp. 63837–63851, 2019.
- [2] S. G. A. Flimban, I. M. I. Ismail, T. Kim, and S.-E. Oh, "Overview of recent advancements in the microbial fuel cell from fundamentals to applications: Design, major elements, and scalability," *Energies*, vol. 12, no. 17, p. 3390, Sep. 2019.
- [3] H. Gul, W. Raza, J. Lee, M. Azam, M. Ashraf, and K.-H. Kim, "Progress in microbial fuel cell technology for wastewater treatment and energy harvesting," *Chemosphere*, vol. 281, Oct. 2021, Art. no. 130828.

- [4] C. Xia, D. Zhang, W. Pedrycz, Y. Zhu, and Y. Guo, "Models for microbial fuel cells: A critical review," *J. Power Sources*, vol. 373, pp. 119–131, Jan. 2018.
- [5] T. Brown, H. LeMay, B. Busten, C. Murphy, and P. Woodward, "Batteries and fuel cells," in *Chemistry—The Central Science*. Davis, CA, USA: Univ. of California Davis, Sep. 2022, p. 21796. [Online]. Available: <https://chem.libretexts.org/@go/page/21796>
- [6] Z. Du, H. Li, and T. Gu, "A state of the art review on microbial fuel cells: A promising technology for wastewater treatment and bioenergy," *Biotechnol. Adv.*, vol. 25, no. 5, pp. 464–482, Sep. 2007.
- [7] J. B. Davis and H. F. Yarbrough, "Preliminary experiments on a microbial fuel cell," *Science*, vol. 137, no. 3530, pp. 615–616, Aug. 1962.
- [8] M. Piccolino, "Luigi Galvani's path to animal electricity," *Comp. Rendus Biol.*, vol. 329, nos. 5–6, pp. 303–318, May 2006.
- [9] M. Piccolino, "Visual images in Luigi Galvani's path to animal electricity," *J. Hist. Neurosci.*, vol. 17, no. 3, pp. 335–348, Jul. 2008.
- [10] N. Kipnis, "Luigi Galvani and the debate on animal electricity, 1791–1800," *Ann. Sci.*, vol. 44, no. 2, pp. 107–142, Mar. 1987.
- [11] L. Fabbri, "Strange case of signor Volta and mister Nicholson: How electrochemistry developed as a consequence of an editorial misconduct," *Angew. Chem. Int. Ed.*, vol. 58, no. 18, pp. 5810–5822, Apr. 2019.
- [12] E. S. Goldensohn, "Animal electricity from Bologna to Boston," *Electroencephalogr. Clin. Neurophysiol.*, vol. 106, no. 2, pp. 94–100, Feb. 1998.
- [13] M. C. Potter, "Electrical effects accompanying the decomposition of organic compounds," *Proc. Roy. Soc. London B, Containing Papers Biol. Character*, vol. 84, no. 571, pp. 260–276, 1911.
- [14] J. M. Hogan and Flynn, "Synthetic biology and microbial fuel cells: Towards self-sustaining life support systems," NASA, Washington, DC, USA, Aug. 2017. [Online]. Available: <https://www.nasa.gov/centers/ames/cct/office/cif/center-innovation-fund-2011-winners/hogan-flynn>
- [15] A. S. Dhoble and P. C. Pullammanappallil, "Design and operation of an anaerobic digester for waste management and fuel generation during long term lunar mission," *Adv. Space Res.*, vol. 54, no. 8, pp. 1502–1512, Oct. 2014, doi: [10.1016/j.asr.2014.06.029](https://doi.org/10.1016/j.asr.2014.06.029).
- [16] I. Shizas and D. M. Bagley, "Experimental determination of energy content of unknown organics in municipal wastewater streams," *J. Energy Eng.*, vol. 130, no. 2, pp. 45–53, Aug. 2004.
- [17] E. Dannys, T. Green, A. Wettlaufer, C. Madhurnathakam, and A. Elkamel, "Wastewater treatment with microbial fuel cells: A design and feasibility study for scale-up in microbreweries," *J. Bioprocess Biotech.*, vol. 6, no. 267, p. 2, 2016.
- [18] A. Pugazhendhi, A. E. Al-Mutairi, M. T. Jamal, R. B. Jeyakumar, and K. Palanisamy, "Treatment of seafood industrial wastewater coupled with electricity production using air cathode microbial fuel cell under saline condition," *Int. J. Energy Res.*, vol. 44, no. 15, pp. 12535–12545, Dec. 2020.
- [19] G. Silveira, S. de Aquino Neto, and J. M. Schneedorf, "Development, characterization and application of a low-cost single chamber microbial fuel cell based on hydraulic couplers," *Energy*, vol. 208, Oct. 2020, Art. no. 118395.
- [20] G. Papaharalabos, A. Stinchcombe, I. Horsfield, C. Melhuish, J. Greenman, and I. Ieropoulos, "Autonomous energy harvesting and prevention of cell reversal in MFC stacks," *J. Electrochem. Soc.*, vol. 164, no. 3, pp. H3047–H3051, 2017.
- [21] P. Aelterman, K. Rabaey, P. Clauwaert, and W. Verstraete, "Microbial fuel cells for wastewater treatment," *Water Sci. Technol.*, vol. 54, no. 8, pp. 9–15, 2006.
- [22] A. Tremouli, J. Greenman, and I. Ieropoulos, "Investigation of ceramic MFC stacks for urine energy extraction," *Bioelectrochemistry*, vol. 123, pp. 19–25, Oct. 2018.
- [23] H. Liu, S. Cheng, and B. E. Logan, "Production of electricity from acetate or butyrate using a single-chamber microbial fuel cell," *Environ. Sci. Technol.*, vol. 39, no. 2, pp. 658–662, Jan. 2005.
- [24] M. M. Ghangrekar, S. R. Asolekar, and S. G. Joshi, "Characteristics of sludge developed under different loading conditions during UASB reactor start-up and granulation," *Water Res.*, vol. 39, no. 6, pp. 1123–1133, Mar. 2005.
- [25] G. S. Jadhav and M. M. Ghangrekar, "Performance of microbial fuel cell subjected to variation in pH, temperature, external load and substrate concentration," *Bioresour. Technol.*, vol. 100, no. 2, pp. 717–723, 2009.
- [26] N. Parker, M. Schneegurt, A. T. Tu, P. Lister, and B. M. Forster, "The effects of pH and temperature on microbial growth," in *Introduction to Microbiology*. Davis, CA, USA: Univ. California Davis, Feb. 2021, p. 31819. [Online]. Available: <https://bio.libretexts.org/@go/page/31819>
- [27] M. Rahimnejad, A. Adhami, S. Darvari, A. Zirepour, and S. E. Oh, "Microbial fuel cell as new technology for bioelectricity generation: A review," *Alexandria Eng. J.*, vol. 54, no. 3, pp. 745–756, 2015.
- [28] S. Mateo, P. Cañizares, F. J. Fernandez-Morales, and M. A. Rodrigo, "A critical view of microbial fuel cells: What is the next stage?" *ChemSusChem*, vol. 11, no. 24, pp. 4183–4192, Dec. 2018.
- [29] J. Li, H. Li, Q. Fu, Q. Liao, X. Zhu, H. Kobayashi, and D. Ye, "Voltage reversal causes bioanode corrosion in microbial fuel cell stacks," *Int. J. Hydrogen Energy*, vol. 42, no. 45, pp. 27649–27656, Nov. 2017.
- [30] K. V. Singh, V. Deep Juyal, A. Chakravorty, N. Upadhyay, and D. Thapliyal, "Approaches in microbial fuel cell array arrangements for conventional DC battery charger," in *Proc. 2nd Int. Conf. Inventive Syst. Control (ICISC)*, Jan. 2018, pp. 418–422, doi: [10.1109/ICISC.2018.8399106](https://doi.org/10.1109/ICISC.2018.8399106).
- [31] F. Khaled, O. Ondel, B. Allard, and N. Degrenne, "Voltage balancing circuit for energy harvesting from a stack of serially-connected microbial fuel cells," in *Proc. IEEE ECCE Asia Downunder*, Jun. 2013, pp. 392–397, doi: [10.1109/ECCE-Asia.2013.6579126](https://doi.org/10.1109/ECCE-Asia.2013.6579126).
- [32] P. Aelterman, K. Rabaey, H. T. Pham, N. Boon, and W. Verstraete, "Continuous electricity generation at high voltages and currents using stacked microbial fuel cells," *Environ. Sci. Technol.*, vol. 40, no. 10, pp. 3388–3394, May 2006.
- [33] V. M. Ortiz-Martínez, M. J. Salar-García, A. P. D. L. Ríos, F. J. Hernández-Fernández, J. A. Egea, and L. J. Lozano, "Developments in microbial fuel cell modeling," *Chem. Eng. J.*, vol. 271, pp. 50–60, Jul. 2015.
- [34] S.-E. Oh and B. E. Logan, "Voltage reversal during microbial fuel cell stack operation," *J. Power Sources*, vol. 167, no. 1, pp. 11–17, 2007.
- [35] H. Wang, J.-D. Park, and Z. J. Ren, "Practical energy harvesting for microbial fuel cells: A review," *Environ. Sci. Technol.*, vol. 49, no. 6, pp. 3267–3277, Mar. 2015.
- [36] A. S. Mathuriya, D. A. Jadhav, and M. M. Ghangrekar, "Architectural adaptations of microbial fuel cells," *Appl. Microbiol. Biotechnol.*, vol. 102, no. 22, pp. 9419–9432, Nov. 2018.
- [37] H. Liu and B. E. Logan, "Electricity generation using an air-cathode single chamber microbial fuel cell in the presence and absence of a proton exchange membrane," *Environ. Sci. Technol.*, vol. 38, no. 14, pp. 4040–4046, 2004.
- [38] A. E. Franks and K. P. Nevin, "Microbial fuel cells, a current review," *Energies*, vol. 3, no. 5, pp. 899–919, Apr. 2010.
- [39] K. Obileke, H. Onyeaka, E. L. Meyer, and N. Nwokolo, "Microbial fuel cells, a renewable energy technology for bio-electricity generation: A mini-review," *Electrochem. Commun.*, vol. 125, Apr. 2021, Art. no. 107003.
- [40] D. A. Jadhav, A. K. Mungray, A. Arkatkar, and S. S. Kumar, "Recent advancement in scaling-up applications of microbial fuel cells: From reality to practicability," *Sustain. Energy Technol. Assessments*, vol. 45, Jun. 2021, Art. no. 101226.
- [41] H. Ni, K. Wang, S. Lv, X. Wang, L. Zhuo, and J. Zhang, "Effects of concentration variations on the performance and microbial community in microbial fuel cell using swine wastewater," *Energies*, vol. 13, no. 9, p. 2231, May 2020.
- [42] J. Wang, X. Song, Y. Wang, Z. Zhao, B. Wang, and D. Yan, "Effects of electrode material and substrate concentration on the bioenergy output and wastewater treatment in air-cathode microbial fuel cell integrating with constructed wetland," *Ecol. Eng.*, vol. 99, pp. 191–198, Feb. 2017.
- [43] A. R. Rahmani, N. Navidjoui, M. Rahimnejad, S. Alizadeh, M. R. Samarghandi, and D. Nematollahi, "Effect of different concentrations of substrate in microbial fuel cells toward bioenergy recovery and simultaneous wastewater treatment," *Environ. Technol.*, vol. 43, no. 1, pp. 1–9, Jan. 2022.
- [44] Z. Ullah and S. Zeshan, "Effect of substrate type and concentration on the performance of a double chamber microbial fuel cell," *Water Sci. Technol.*, vol. 81, no. 7, pp. 1336–1344, Apr. 2020.
- [45] Y. Song, J. An, and K.-J. Chae, "Effect of temperature variation on the performance of microbial fuel cells," *Energy Technol.*, vol. 5, no. 12, pp. 2163–2167, Dec. 2017.

- [46] P.-F. Tee, M. O. Abdullah, I. A. W. Tan, M. A. M. Amin, C. Nolasco-Hipolito, and K. Bujang, "Effects of temperature on wastewater treatment in an affordable microbial fuel cell-adsorption hybrid system," *J. Environ. Chem. Eng.*, vol. 5, no. 1, pp. 178–188, Feb. 2017.
- [47] A. Tremouli, M. Martinos, and G. Lyberatos, "The effects of salinity, pH and temperature on the performance of a microbial fuel cell," *Waste Biomass Valorization*, vol. 8, no. 6, pp. 2037–2043, Sep. 2017.
- [48] S. Wang, J. Zhao, S. Liu, R. Zhao, and B. Hu, "Effect of temperature on nitrogen removal and electricity generation of a dual-chamber microbial fuel cell," *Water, Air, Soil Pollut.*, vol. 229, no. 8, pp. 1–13, Aug. 2018.
- [49] M. S. Hamed, H. S. Majdi, and B. O. Hasan, "The effect of temperature on electrical energy production in double chamber microbial fuel cell using different electrode materials," *Mater. Today, Proc.*, vol. 42, pp. 3018–3021, Jan. 2021.
- [50] V. Margaria, T. Tommasi, S. Pentassuglia, V. Agostino, A. Sacco, C. Armato, A. Chiodoni, T. Schilirò, and M. Quaglio, "Effects of pH variations on anodic marine consortia in a dual chamber microbial fuel cell," *Int. J. Hydrogen Energy*, vol. 42, no. 3, pp. 1820–1829, Jan. 2017.
- [51] S. V. Raghavulu, S. V. Mohan, R. K. Goud, and P. N. Sarma, "Effect of anodic pH microenvironment on microbial fuel cell (MFC) performance in concurrence with aerated and ferricyanide catholytes," *Electrochem. Commun.*, vol. 11, no. 2, pp. 371–375, Feb. 2009.
- [52] T. E. Igboamalu, N. Bezuidenhout, M. T. Matsena, and E. Chirwa, "Microbial fuel cell power output and growth: Effect of pH on anaerobic microbe consortium," *Chem. Eng. Trans.*, vol. 76, pp. 1381–1386, Jul. 2019.
- [53] N. M. Azmi, N. Anandita, H. A. Tajarudin, N. F. Shoparwe, and M. M. Z. Makhtar, "Membrane-less microbial fuel cell: Effect of pH on the electricity generation powered by municipal food waste," *J. Phys., Conf. Ser.*, vol. 2129, no. 1, Dec. 2021, Art. no. 012095.
- [54] M. A. Halim, M. O. Rahman, M. Ibrahim, R. Kundu, and B. K. Biswas, "Effect of anolyte pH on the performance of a dual-chambered microbial fuel cell operated with different biomass feed," *J. Chem.*, vol. 2021, pp. 1–8, Aug. 2021.
- [55] M. T. Noori, M. M. Ghangrekar, C. K. Mukherjee, and B. Min, "Biofouling effects on the performance of microbial fuel cells and recent advances in biotechnological and chemical strategies for mitigation," *Biotechnol. Adv.*, vol. 37, no. 8, Dec. 2019, Art. no. 107420, doi: 10.1016/j.biotechadv.2019.107420.
- [56] F. Ma, Y. Yin, and K. Sun, "Fault diagnosis of microbial fuel cell based on wavelet packet and SOM neural network," in *Proc. Chin. Control Decis. Conf. (CCDC)*, Jun. 2019, pp. 367–372, doi: 10.1109/CCDC.2019.8832962.
- [57] F. Ma, L. Lian, P. Ji, Y. Yin, and W. Chen, "Fault diagnosis scheme based on microbial fuel cell model," *IEEE Access*, vol. 8, pp. 224306–224317, 2020, doi: 10.1109/ACCESS.2020.3044354.
- [58] F. Nourbakhsh, M. Pazouki, and M. Mohsemmia, "Simultaneous investigation of three effective parameters of substrate, microorganism type and reactor design on power generation in a dual-chamber microbial fuel cells," *Iranian J. Biotechnol.*, vol. 18, no. 2, 2020, Art. no. e2292, doi: 10.30498/ijb.2020.132869.2292.
- [59] K. A. Dwivedi, S.-J. Huang, C.-T. Wang, and S. Kumar, "Fundamental understanding of microbial fuel cell technology: Recent development and challenges," *Chemosphere*, vol. 288, Feb. 2022, Art. no. 132446, doi: 10.1016/j.chemosphere.2021.132446.
- [60] C. Sato, N. E. Paucar, S. Chiu, M. Z. I. M. Mahmud, and J. Dudgeon, "Single-chamber microbial fuel cell with multiple plates of bamboo charcoal anode: Performance evaluation," *Processes*, vol. 9, no. 12, p. 2194, Dec. 2021, doi: 10.3390/pr9122194.
- [61] I. T. Vargas, N. Tapia, and J. M. Regan, "Rumen inoculum enhances cathode performance in single-chamber air-cathode microbial fuel cells," *Materials*, vol. 15, no. 1, p. 379, Jan. 2022, doi: 10.3390/ma15010379.
- [62] E. A. E. Sakr, D. Z. Khater, and K. M. El-khatib, "Anodic and cathodic biofilms coupled with electricity generation in single-chamber microbial fuel cell using activated sludge," *Bioprocess Biosyst. Eng.*, vol. 44, no. 12, pp. 2627–2643, Dec. 2021, doi: 10.1007/s00449-021-02632-5.
- [63] Y. R. J. Thomas, M. Picot, A. Carer, O. Berder, O. Sentieys, and F. Barrière, "A single sediment-microbial fuel cell powering a wireless telecommunication system," *J. Power Sources*, vol. 241, pp. 703–708, Nov. 2013.
- [64] B. Xu, Z. Ge, and Z. He, "Sediment microbial fuel cells for wastewater treatment: Challenges and opportunities," *Environ. Sci., Water Res. Technol.*, vol. 1, no. 3, pp. 279–284, 2015.
- [65] A. K. Yadav, P. Dash, A. Mohanty, R. Abbassi, and B. K. Mishra, "Performance assessment of innovative constructed wetland-microbial fuel cell for electricity production and dye removal," *Ecol. Eng.*, vol. 47, pp. 126–131, Oct. 2012, doi: 10.1016/j.ecoleng.2012.06.029.
- [66] D. P. B. T. B. Strik, H. V. M. H. Bert, J. F. H. Snel, and C. J. N. Buisman, "Green electricity production with living plants and bacteria in a fuel cell," *Int. J. Energy Res.*, vol. 32, no. 9, pp. 870–876, Jul. 2008.
- [67] Z. Yang, L. Zhang, C. Nie, Q. Hou, S. Zhang, and H. Pei, "Multiple anodic chambers sharing an algal raceway pond to establish a photosynthetic microbial fuel cell stack: Voltage boosting accompany wastewater treatment," *Water Res.*, vol. 164, Nov. 2019, Art. no. 114955.
- [68] J. K. Nayak and U. K. Ghosh, "Post treatment of microalgae treated pharmaceutical wastewater in photosynthetic microbial fuel cell (PMFC) and biodiesel production," *Biomass Bioenergy*, vol. 131, Dec. 2019, Art. no. 105415.
- [69] Z. He, S. D. Minter, and L. T. Angenent, "Electricity generation from artificial wastewater using an upflow microbial fuel cell," *Environ. Sci. Technol.*, vol. 39, no. 14, pp. 5262–5267, Jul. 2005.
- [70] W.-E. Thung, S.-A. Ong, L.-N. Ho, Y.-S. Wong, Y.-L. Oon, Y.-S. Oon, and H. K. Lehl, "Simultaneous wastewater treatment and power generation with innovative design of an upflow membrane-less microbial fuel cell," *Water, Air, Soil Pollut.*, vol. 226, no. 5, pp. 1–7, May 2015.
- [71] J. An, B. Kim, J. K. Jang, H.-S. Lee, and I. S. Chang, "New architecture for modularization of membraneless and single-chambered microbial fuel cell using a bipolar plate-electrode assembly (BEA)," *Biosensors Bioelectron.*, vol. 59, pp. 28–34, Sep. 2014.
- [72] J. Winfield, I. Ieropoulos, and J. Greenman, "Investigating a cascade of seven hydraulically connected microbial fuel cells," *Bioresour. Technol.*, vol. 110, pp. 245–250, Apr. 2012, doi: 10.1016/j.biortech.2012.01.095.
- [73] A. S. Mathuriya, "Novel microbial fuel cell design to operate with different wastewaters simultaneously," *J. Environ. Sci.*, vol. 42, pp. 105–111, Apr. 2016.
- [74] A. Mathuriya, "Novel microbial auto flow fuel cell (MAFFC) architecture for large scale energy efficient wastewater treatment," *Intellectual Property J. India*, vol. 23, no. 2016, 2016, Art. no. 23155.
- [75] Z. Li, X. Zhang, Y. Zeng, and L. Lei, "Electricity production by an overflow-type wetted-wall microbial fuel cell," *Bioresour. Technol.*, vol. 100, no. 9, pp. 2551–2555, May 2009.
- [76] K. Scott, E. H. Yu, M. M. Ghangrekar, B. Erable, and N. M. Duteanu, "Biological and microbial fuel cells," in *Comprehensive Renewable Energy*. Alpharetta, GA, USA: Elsevier, 2012, pp. 277–300.
- [77] N. W. Zhu, X. Chen, L. X. Tu, P. X. Wu, and Z. Dang, "Voltage reversal during stacking microbial fuel cells with or without diodes," in *Advanced Materials Research*, vols. 396–398. Switzerland: Trans Tech Publications, 2021, pp. 188–193, doi: 10.4028/www.scientific.net/AMR.396-398.188.
- [78] S. Bagchi and M. Behera, "Microbial fuel cells: A sustainable technology for pollutant removal and power generation," in *Bioelectrochemical Interface Engineering*. Hoboken, NJ, USA: Wiley, 2019, pp. 91–116.
- [79] E. A. Mukhaifi and S. A. Abduljaleel, "Electric bacteria: A review," *J. Adv. Lab. Res. Biol.*, vol. 11, no. 1, pp. 7–15, 2020.
- [80] A. J. Slate, K. A. Whitehead, D. A. C. Brownson, and C. E. Banks, "Microbial fuel cells: An overview of current technology," *Renew. Sustain. Energy Rev.*, vol. 101, pp. 60–81, Mar. 2019, doi: 10.1016/j.rser.2018.09.044.
- [81] K. A. Dwivedi, S.-J. Huang, and C.-T. Wang, "Integration of various technology-based approaches for enhancing the performance of microbial fuel cell technology: A review," *Chemosphere*, vol. 287, Jan. 2022, Art. no. 132248, doi: 10.1016/j.chemosphere.2021.132248.
- [82] J. Zhang, Y. Bai, Y. Fan, and H. Hou, "Improved bio-hydrogen production from glucose by adding a specific methane inhibitor to microbial electrololysis cells with a double anode arrangement," *J. Biosci. Bioeng.*, vol. 122, no. 4, pp. 488–493, Oct. 2016, doi: 10.1016/j.jbiosc.2016.03.016.
- [83] S. K. Chaudhuri and D. R. Lovley, "Electricity generation by direct oxidation of glucose in mediatorless microbial fuel cells," *Nature Biotechnol.*, vol. 21, no. 10, pp. 1229–1232, Oct. 2003, doi: 10.1038/nbt867.
- [84] F. M. Mims, *Getting Started in Electronics*. New York, NY, USA: Master Publishing, 2003.
- [85] P. H. W. Hill, *The Art of Electronics*. 3rd ed. New York, NY, USA: Cambridge Univ. Press, 2016, p. 1225.
- [86] The Editors of Encyclopaedia Britannica. *Electric Current*. Accessed: Jun. 23, 2022. [Online]. Available: <https://www.britannica.com/science/electric-current>

- [87] B. Kim, S. V. Mohan, D. Fapyane, and I. S. Chang, "Controlling voltage reversal in microbial fuel cells," *Trends Biotechnol.*, vol. 38, no. 6, pp. 667–678, Jun. 2020.
- [88] S. Wu, H. Li, X. Zhou, P. Liang, X. Zhang, Y. Jiang, and X. Huang, "A novel pilot-scale stacked microbial fuel cell for efficient electricity generation and wastewater treatment," *Water Res.*, vol. 98, pp. 396–403, Jul. 2016.
- [89] E. B. Estrada-Arriaga, J. Hernández-Romano, L. García-Sánchez, R. A. G. Garcés, E. O. Bahena-Bahena, O. Guadarrama-Pérez, and G. E. M. Chavez, "Domestic wastewater treatment and power generation in continuous flow air-cathode stacked microbial fuel cell: Effect of series and parallel configuration," *J. Environ. Manag.*, vol. 214, pp. 232–241, May 2018, doi: [10.1016/j.jenvman.2018.03.007](https://doi.org/10.1016/j.jenvman.2018.03.007).
- [90] P. Ledezma, J. Greenman, and I. Ieropoulos, "MFC-cascade stacks maximise COD reduction and avoid voltage reversal under adverse conditions," *Bioresour. Technol.*, vol. 134, pp. 158–165, Apr. 2013.
- [91] R. H. Huang, B. Mo, F. Zhao, and C. D. Ling, "Voltage reversal of microbial fuel cells stacked in serial," in *Key Engineering Materials*, vol. 609. Zürich, Switzerland: Trans Tech Publications, 2014, pp. 1422–1427.
- [92] J. An, J. Sim, and H.-S. Lee, "Control of voltage reversal in serially stacked microbial fuel cells through manipulating current: Significance of critical current density," *J. Power Sources*, vol. 283, pp. 19–23, Jun. 2015.
- [93] J. An, B. Kim, I. S. Chang, and H.-S. Lee, "Shift of voltage reversal in stacked microbial fuel cells," *J. Power Sources*, vol. 278, pp. 534–539, Mar. 2015.
- [94] B. Kim, B.-G. Lee, B. H. Kim, and I. S. Chang, "Assistance current effect for prevention of voltage reversal in stacked microbial fuel cell systems," *ChemElectroChem*, vol. 2, no. 5, pp. 755–760, May 2015.
- [95] Y. S. Lee, J. An, B. Kim, and I. S. Chang, "Serially connectable sediment microbial fuel cells using dipole graphite solids and voltage reversal suppression," *Energy Technol.*, vol. 5, no. 11, pp. 1946–1952, Nov. 2017.
- [96] Y. Kim, M. C. Hatzell, A. J. Hutchinson, and B. E. Logan, "Capturing power at higher voltages from arrays of microbial fuel cells without voltage reversal," *Energy Environ. Sci.*, vol. 4, no. 11, pp. 4662–4667, 2011.
- [97] B. Kim and I. S. Chang, "Elimination of voltage reversal in multiple membrane electrode assembly installed microbial fuel cells (mMEA-MFCs) stacking system by resistor control," *Bioresour. Technol.*, vol. 262, pp. 338–341, Aug. 2018.
- [98] *Microbial Fuel Cells (MFC)—Global Market Outlook (2017–2026)*, Asian Intell. Center, Hyderabad, India, Aug. 2019. [Online]. Available: <https://www.strategymrc.com/report/microbial-fuel-cells-mfc-market>
- [99] W. H. Tan, S. Chong, H.-W. Fang, K.-L. Pan, M. Mohamad, J. W. Lim, T. J. Tiong, Y. J. Chan, C.-M. Huang, and T. C.-K. Yang, "Microbial fuel cell technology—A critical review on scale-up issues," *Processes*, vol. 9, no. 6, p. 985, Jun. 2021, doi: [10.3390/pr9060985](https://doi.org/10.3390/pr9060985).
- [100] T. Tommasi and G. Lombardelli, "Energy sustainability of microbial fuel cell (MFC): A case study," *J. Power Sources*, vol. 356, pp. 438–447, Jul. 2017, doi: [10.1016/j.jpowsour.2017.03.122](https://doi.org/10.1016/j.jpowsour.2017.03.122).
- [101] A. Mukherjee, V. Patel, M. T. Shah, D. A. Jadhav, N. S. Munshi, A. D. Chendake, and D. Pant, "Effective power management system in stacked microbial fuel cells for onsite applications," *J. Power Sources*, vol. 517, Jan. 2022, Art. no. 230684, doi: [10.1016/j.jpowsour.2021.230684](https://doi.org/10.1016/j.jpowsour.2021.230684).
- [102] A. Dutta, C. A. Jacob, P. Das, E. Corton, D. Stom, L. Barbora, and P. Goswami, "A review on power management systems: An electronic tool to enable microbial fuel cells for powering range of electronic appliances," *J. Power Sources*, vol. 517, Jan. 2022, Art. no. 230688, doi: [10.1016/j.jpowsour.2021.230688](https://doi.org/10.1016/j.jpowsour.2021.230688).



GANESAN V. MURUGESU received the B.Eng. degree in electrical and electronic engineering from Universiti Sains Malaysia, Perak, Malaysia, in 1999, and the master's degree in electrical and electronics engineering from Universiti Teknologi Malaysia, Johor, Malaysia, in 2009, where he is currently pursuing the Ph.D. degree in electrical and electronics engineering.



SAIFUL NIZAM KHALID received the B.Eng., M.E.E., and Ph.D. degrees from Universiti Teknologi Malaysia, Johor Bahru, Malaysia, in 1998, 2000, and 2009, respectively.

He is currently an Associate Professor with the Faculty of Engineering, School of Electrical Engineering, Universiti Teknologi Malaysia. His research interests include deregulated power systems, application of artificial neural networks in power systems, power tracing, and smart metering applications.



HUSSAIN SHAREEF (Member, IEEE) received the Ph.D. degree from Universiti Teknologi Malaysia (UTM), in 2007. He is a Professor with the Department of Electrical and Communication Engineering, United Arab Emirates University, and the Head of the Emirates Center for Mobility Research, Green Mobility Research Team. He has published more than 400 peer-reviewed journal articles in various fields related to power and energy systems. He has more than 5500 citations with an h-index of 37. His research interests include power system planning, the integration of renewable power sources, the application of AI techniques in power systems, energy management, power quality, and electric vehicle grid integration. He is a member of the Mohammed Bin Rashid Academy of Scientists. He appeared as the world's top 2% scientists at Stanford University, from 2020 to 2022. He was a recipient of the UAE University Award for Excellence in Scholarship, from 2019 to 2020, and the Chancellor Innovation Award, from 2020 to 2021.

• • •