

## RESEARCH ARTICLE

# A Novel Tri-Stage RIA Scheme for Cooperative Cell Edge Users in a Multi-Cellular MIMO IMAC

VIVEK MENON U<sup>ID</sup> AND POONGUNDRAN SELVAPRABHU<sup>ID</sup>

Department of Communication Engineering, School of Electronics Engineering (SENSE), Vellore Institute of Technology, Vellore, Tamil Nadu 632014, India

Corresponding author: Poongundran Selvaprabhu (poongundran.selvaprabhu@vit.ac.in)

This work was supported by the School of Electronics Engineering (SENSE), Vellore Institute of Technology, Vellore, Tamil Nadu, India.

**ABSTRACT** In the real world of wireless communication systems, one solution to the practical limitation of interference alignment in terms of global channel state information at the transmitter (CSIT) requirement is to consider a linear precoding approach that only uses delayed CSIT known as retrospective interference alignment (RIA). Therefore, in the proposed work, a novel RIA scheme for the cooperative cell edge (CE) users that are more vulnerable to inter-cell interference in a multi-cellular multiple-input multiple-output (MIMO) interference multiple access channels (IMAC) is presented. The core idea of the proposed RIA is characterized by interference refining at the end of the first two stages and interference redirecting at the third stage. The initial stage 1 involves feeding the base station (BS) in cell-1 with the data streams from the cooperative CE users. During stage 2, the BS in cell-2 is fed with data streams from the cooperative CE users in cell-2. In the final stage 3, the overheard equation redirecting is performed. Based on the proposed method, we showed that for a three CE user cooperative multi-cellular MIMO IMAC channel, the achievable degrees of freedom (DoF) is  $\frac{24}{7}$  and later extended to a general  $L$ -CE user cooperative multi-cellular MIMO IMAC channel and obtained the desired DoF as  $\frac{2L(L+1)}{2L+1}$ . The simulation result shows that in comparison with the other benchmark schemes considered, the proposed scheme provides a greater DoF and thereby enhances the performance of cooperative CE users.

**INDEX TERMS** Channel state information at the transmitter, degrees of freedom, interference management, retrospective interference alignment.

## I. INTRODUCTION

One of the factors supporting the expansion of the wireless industry is the massive hike in mobile data traffic. With the flourishing wireless industry, interference management has become a hot topic in academia and industry [1]. Interference alignment (IA) is one such noteworthy interference management approach that handles the positioning of signals. These signals are positioned to generate an overlapping shadow at the unintended receivers, while the desired interference-free signals remain distinct at the intended receivers [2]. However, the requirement of perfect knowledge of global channel state information at the transmitter (CSIT) acts as a practical constraint for IA in real-world wireless communication systems. Furthermore, in a practical system, the CSIT obtained

is usually imperfect because of the channel's time-varying characteristics, errors in estimation, feedback, quantization and so forth. These practical constraints in obtaining the perfect CSIT were overcome at first in [3] by introducing the novel concept of retrospective interference alignment (RIA). Thus, RIA points to a linear precoding approach that utilizes only the delayed CSIT [4]. Also, it is observed that closely associated with the RIA scheme, the then-existing IA schemes such as space-time interference alignment with moderately delayed CSIT [5], [6], blind IA with no knowledge of CSIT [7], [8] aid in imparting novel insight into the interplay between the delay in channel state information (CSI) feedback and the performance of the system in terms of sum degrees of freedom (DoF) gain.

Before the pioneering works in [3] and [9], the common consensus was that the knowledge of the channel is only beneficial to the transmitter if it aids in learning the present

The associate editor coordinating the review of this manuscript and approving it for publication was Barbara Masini<sup>ID</sup>.

channel state. Through introducing RIA, the prior consensus regarding the channel state was proved wrong as the delayed CSIT independent of the present channel state is valuable enough to enhance the DoF. The works in [10], [11], [12], [13], [14], [15], [16], [17], [18], [19], [20], [21], [22], [23], [24], [25], [26], [27], and [28] illustrate the diversity of research works performed in the field of RIA. Table 1 illustrates some recent works on RIA. In [10], the authors illustrate the feasibility of RIA in an interference network comprising distributed transmitters and receivers in which the interference is contributed by the numerous transmitters, where each transmitter reconstructs only a part of the interference caused by themselves. Furthermore, this work illustrates that a DoF of  $\frac{9}{8}$  and  $\frac{8}{7}$  is attained by a three-user interference channel (IC) and a two-user X channel with delayed CSIT respectively. Also, it is observed that  $\frac{6}{5}$  and  $\frac{4}{3}$  DoF are individually achieved by a three-user IC and X channel when delayed output feedback is available to the transmitters.

The authors in [16] at first established the usefulness of the completely stale CSI. Furthermore, it was illustrated that in a MIMO BC channel, having  $K$  number of transmitter antennas and  $K$  number of receivers with each having one antenna is capable of attaining a DoF of  $\left[ \frac{K}{(1+\frac{1}{2}+\dots+\frac{1}{K})} \right]$  even when the feedback channel is completely independent of the current channel state. This result can be viewed as the first example of feedback providing a DoF gain in the memoryless channel. The notion of fast fading and delayed knowledge of CSIT is used by the authors in [17] for obtaining the inner and outer bounds of DoF for a MIMO IC with two users. Under the delayed CSIT assumption, the authors in [18] proposed a multi-stage IA scheme that attains an improved DoF for a single-input single-output (SISO) additive white gaussian noise (AWGN) IC with  $K$  users and a  $2 \times K$  SISO AWGN X channel. The authors studies in [19] showed that a MIMO IC with output feedback combined with delayed CSIT obtains a DoF, where this obtained DoF is equivalent to the DoF of the perfect CSIT. The novelty of the proposed scheme compared to the other existing schemes is that each terminal of the MIMO IC is characterized by arbitrarily numerous antennas. The application of RIA on a MIMO IC with three users is illustrated by the authors in work [20]. Later the authors in [21] proposed an RIA scheme for a MIMO IC having  $K$  users with  $M$  antennas at the transmitter and  $N$  antennas at the receiver. Thereafter, the authors in [22] illustrated an RIA scheme on a SISO IC with  $K$  users and disclosed that the DoF grows in proportion to the square root of the number of users.

In the presence of delayed CSIT for an X channel and an X network, the authors in [23] derived the DoF as  $\frac{6}{5}$  and  $\frac{5}{4}$  respectively. Similarly, with the knowledge of delayed CSIT using linear encoding techniques the authors in [24] obtained the linear DoF for a gaussian X channel with two users as  $\frac{6}{5}$  and an IC with three users as  $\frac{9}{7}$ . Then the authors of [25] determined the achievable sum DoF of MIMO X networks with numerous users having local and moderately delayed CSIT by using RIA. By considering linear coding techniques

at the transmitter, the authors [26] analyzed and determined the linear sum DoF of a delayed CSIT-based MIMO X channel having two configurations, where the former points to a general antenna configuration and the latter points to the symmetric antenna configuration. Later, the authors in [27] emphasize the significance of feedback and the presence of delayed CSIT in a MIMO X channel and assess that the DoF attained by the MIMO X channel is similar to that obtained in the MIMO BC channel. Furthermore, in the presence of delayed CSIT, for a MIMO gaussian BC under independent and identically distributed fading, the authors in [28] obtained the outer bound to the DoF. Then, for the interference BC, an RIA scheme with four phases was proposed [29].

The application of IA and RIA in standard network topologies like interference multiple access channels (IMAC) is illustrated by the authors in [30], [31], and [32]. Thus, IMAC is defined as a scenario in which each cell consisting of numerous transmitters simultaneously transmits the information to the base station (BS) and the transmission that occurs between the different cells results in interference. The practical significance of IMAC is that it develops an environment suitable for uplink communication consisting of numerous neighboring cells. In [33] for a MIMO IMAC with two cells, the authors presented a new RIA scheme that attains a DoF of  $\left[ \frac{2M(\lceil \frac{2M}{N} \rceil + 1)}{(2\lceil \frac{2M}{N} \rceil + 1)} \right]$  where  $M$  denotes the number of antennas at the receiving BS and  $N$  denotes the number of transmitter antennas present on the  $K$  users of each cell. Thus, from the above-mentioned literature works, it can be observed that a plethora of research works illustrate the application of RIA in cellular networks. Later, in a two-cell Z interference MIMO channel, the authors in [34], classified the mobile users into two groups based on their position from the BS. They are the cell center (CC) users that lie in the proximity of the BS and the cell edge (CE) users located further away from the BS [35]. Furthermore, the authors in [36] considered multi-cell MIMO cooperative networks with cooperative CE mobile users and investigated the power allocation and feasibility criteria.

## A. MOTIVATION AND SUMMARY OF CONTRIBUTIONS

The proposed work is motivated by the fact that cooperative CE users in a multi-cellular MIMO IMAC are more vulnerable to inter-cell interference (ICI) issues. This issue of ICI faced by the cooperative CE users in a multi-cellular MIMO IMAC can be overcome by introducing a tri-staged scheme, an outdated CSIT-based RIA scheme.

The following are the key contributions of this paper:

- The novelty of this research is that a tri-staged, outdated CSIT-based RIA scheme is proposed for a multi-cellular MIMO IMAC. The reason for considering the RIA scheme is to overcome the practical constraints in obtaining the perfect CSIT.
- In the proposed work, the users are classified into three categories: CC users, cell median (CM) users and CE

TABLE 1. Recent works on RIA.

Year	Author	Summary
2019	Mohamed Seif <i>et al.</i>	The authors of [11] presented a new secure RIA technique for an IC with $K$ users, wherein the transmitter precisely/meticulously integrates the information symbol with artificial noises to preserve confidentiality.
2020	Wei Liu <i>et al.</i>	The authors in [12] presented a sophisticated cache-aided RIA strategy in a multiple-input single-output (MISO) broadcast channel (BC) to nullify the interference by utilizing the cached content.
2021	Jingfu Li <i>et al.</i>	To overcome the issues of traditional IA schemes in terms of increased computational complexity and practical difficulties in attaining the global and instantaneous CSI, the authors in [13] proposed two new IA schemes for downlink cellular $K$ -user multiple-input multiple-output (MIMO) networks. The two new IA schemes proposed are retrospective interference regeneration (RIR) schemes and beamforming-based distributed retrospective IA schemes.
2021	Weiheng Jiang <i>et al.</i>	For the downlink MIMO networks with a varied number of users, the authors in [14] proposed three unique and novel joint IA strategies. They are hybrid antenna array-based partial interference elimination and RIR scheme; hybrid antenna array-based improved partial interference elimination and RIR schemes; hybrid antenna array-based cyclic interference elimination and RIR scheme. As a result, these schemes can overcome the problems of IA approaches, causing information delay and further enhancing the capacity of the system based on the RIA scheme.
2022	Wei Liu <i>et al.</i>	The authors in [15] presented a sophisticated cache-aided RIA strategy in a MISO BC to nullify the interference by utilizing the cached content.

users. The CE users that are more vulnerable to ICI are considered in this work and applied the tri-staged, outdated, CSIT-based RIA scheme.

- The DoF for cooperative three CE users and a general cooperative  $L$ -CE users in a multi-cellular MIMO IMAC are calculated. The DoF for a cooperative three CE user multi-cellular MIMO IMAC is determined to be  $\frac{24}{7}$  and the DoF for a cooperative  $L$ -CE user multi-cellular MIMO IMAC is determined to be  $\frac{2L(L+1)}{2L+1}$ .
- The simulation result shows that the proposed scheme achieves enhanced DoF that scales with the number of CE users.

## B. ORGANIZATION

The remaining sections and their contributions are as follows: the system model for cooperative  $L$ -CE user in a multi-cellular MIMO IMAC is described in section II. The subsection that follows section II illustrates the notion of cooperative multi-cellular MIMO networks, non-cooperation among users, cooperation among CE users, fractional frequency reuse and soft frequency reuse. It also illustrates how the user locations are determined. Section III describes the proposed outdated CSIT-based RIA scheme for cooperative three-CE users in a multi-cellular MIMO IMAC channel and section IV illustrates the same outdated CSIT-based RIA scheme for a generalised  $L$ -CE user multi-cellular MIMO IMAC channel. In section V, the numerical results associated with the proposed scheme is illustrated. Finally, the paper is concluded in section VI.

## II. SYSTEM MODEL

The system model considered in the proposed work is for an uplink cellular network that operates at the same frequency. That is specifically for an  $L$ -CE user cooperative multi-cellular MIMO IMAC wherein  $L \geq 2$ . Figure 1 illustrates the system model for a cooperative  $L$ -CE user multi-cellular MIMO IMAC. The individual cells in the cooperative multi-cellular network are characterized by a single BS and a varying number of users. In the proposed system

model, the cell (BS present in the cell denoted by BS-C) that receives the interference from the users of the other cells is assumed to be present in the idle condition. Thus, this cell consists of only a BS and no users are present. The user  $[l,k]$  represents the  $l^{\text{th}}$  user in the  $k^{\text{th}}$  cell where  $l \in \{1, 2, \dots, L\}$  and  $k \in \{1, 2, \dots, K\}$ .  $M$  and  $N$  denote the antennas equipped at the users and the BSs, respectively, wherein the values of  $\{M, N\} \geq 2$ . Thus, by considering the settings mentioned above, the proposed system model can be, in general, represented as  $(N, M, L)$  MIMO IMAC. Incorporating the condition of  $N \geq M$  in the proposed work leads to a more pragmatic cellular environment.

The concept of cellular frequency reuse (FR) is used in the proposed system model to select only those cells having the same frequency. Thus, a co-channel interference occurring between the users in cell-1 and cell-2 due to simultaneous transmission is aligned in the direction of the BS-C. Also, here the channels are assumed to be independent of time and the cooperative CE users transmitters are assumed to have a delayed knowledge of CSI through a noiseless feedback link, while the receiving BSs are assumed to have an instantaneous global channel state information at the receiver (CSIR). The received signal  $Rx^{[a]}(t)$  at the  $a^{\text{th}}$  BS for a total of  $2L$  cooperative CE users that simultaneously transmits their signal at the  $t^{\text{th}}$  time slot is denoted by:

$$Rx^{[a]}(t) = \sum_{k=1}^K \sum_{l=1}^L H_a^{[l,k]}(t) \times Tx^{[l,k]}(t) + n^{[a]}(t). \quad (1)$$

Here, the channel matrix from the  $l^{\text{th}}$  cooperative CE user in the  $k^{\text{th}}$  cell denoted by user  $[l,k]$  to the  $a^{\text{th}}$  BS is denoted by  $H_a^{[l,k]}(t)$ , the transmit signal vector from the user  $[l,k]$  over the time slot  $t$  with  $E\|Tx^{[l,k]}(t)\|^2 \leq P$  as the average power constraint is denoted by  $Tx^{[l,k]}(t)$  and the noise term at the  $a^{\text{th}}$  BS is denoted by  $n^{[a]}(t)$ .

## A. COOPERATIVE MULTI-CELLULAR MIMO NETWORK

The emphasis of this section is on multi-cellular MIMO networks with the contemplation of cooperation among CE

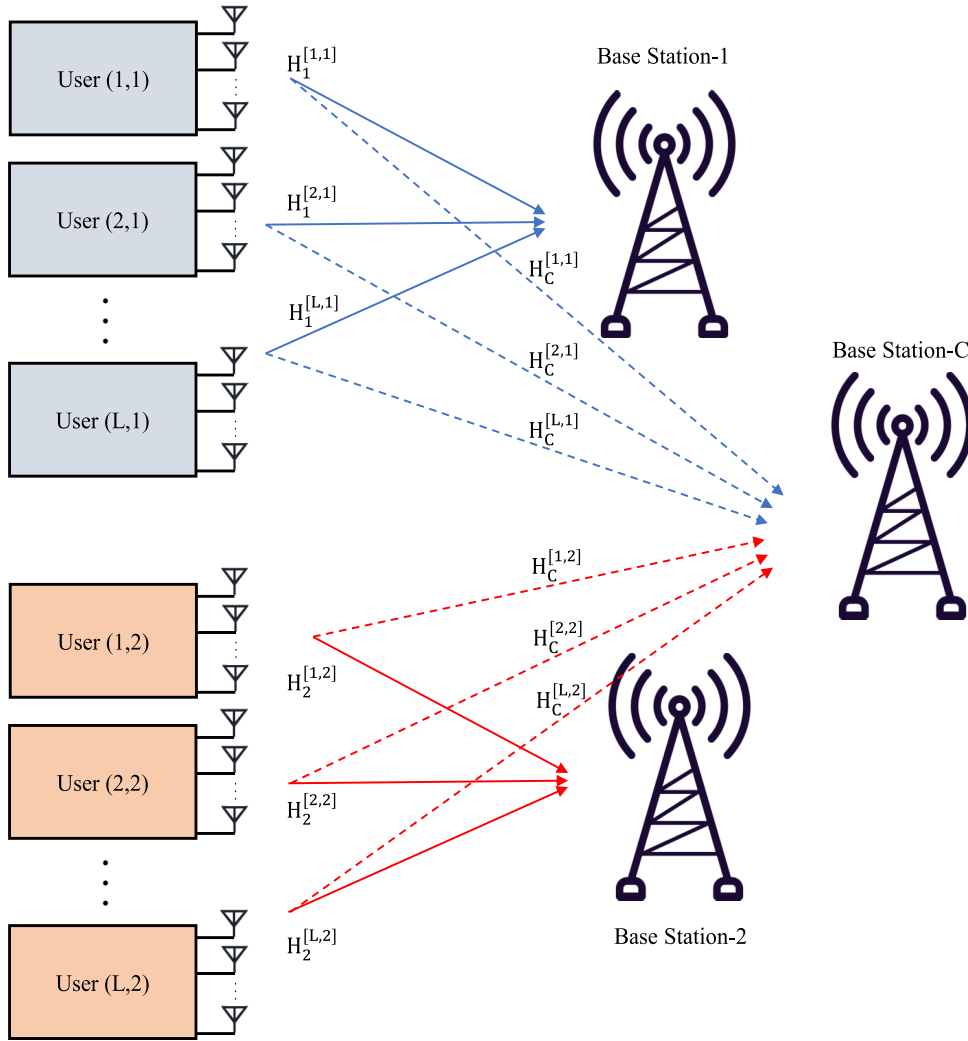

FIGURE 1. L-CE users multi-cellular MIMO IMAC.

mobile users. The proposed system model focuses on the frequency reuse technique to improve the cooperative CE mobile users performance. The BS cooperation encompasses the control dissemination, data signal transmission, the transmission of precoders and CSI over the wired backhaul links that aid in enhanced synchronization between the transmitters to the mobile users. The BS utilizes this information to adjust its surroundings and initialize communication approaches as per the required conditions of the channel. Figure 2 depicts the classification of mobile users in a multi-cellular MIMO network, wherein the CC mobile users are {1,2}, CM mobile users are {3} and the CE mobile users are {4,5}.

**B. NON-COOPERATION AMONG USERS**

The non-cooperative transmission scheme among the different classifications of mobile users is addressed in the normal mode of operation. The relationship between the capacity of the mobile users under the non-cooperative transmission scheme ( $C_{NC}$ ) and signal to interference plus noise

ratio (SINR) of the non-cooperative transmission scheme ( $SINR_{NC}$ ) for the downlink MIMO Gaussian IC is represented by the following equation:

$$C_{NC} = \log_2(1 + \lambda SINR_{NC}). \tag{2}$$

The  $C_{NC}$  in bits/s/Hz is characterized by using the Shannon capacity formula and  $\lambda$  denotes the SINR gap between the practical and theoretical coding approaches.

**C. COOPERATION AMONG CE USERS**

An enhanced sum rate and throughput are attained by the full cooperation among all the users. In a multi-cellular MIMO network, these mobile users are classified into CC, CM and CE users; out of these, the CE users are affected by the co-channel interference from the adjacent cells. The full cooperation aids in enhancing the cost efficiency in view of the vast volume of information shared among the users and the BS's. Nevertheless, the full cooperation among the different classifications of mobile users results in increased

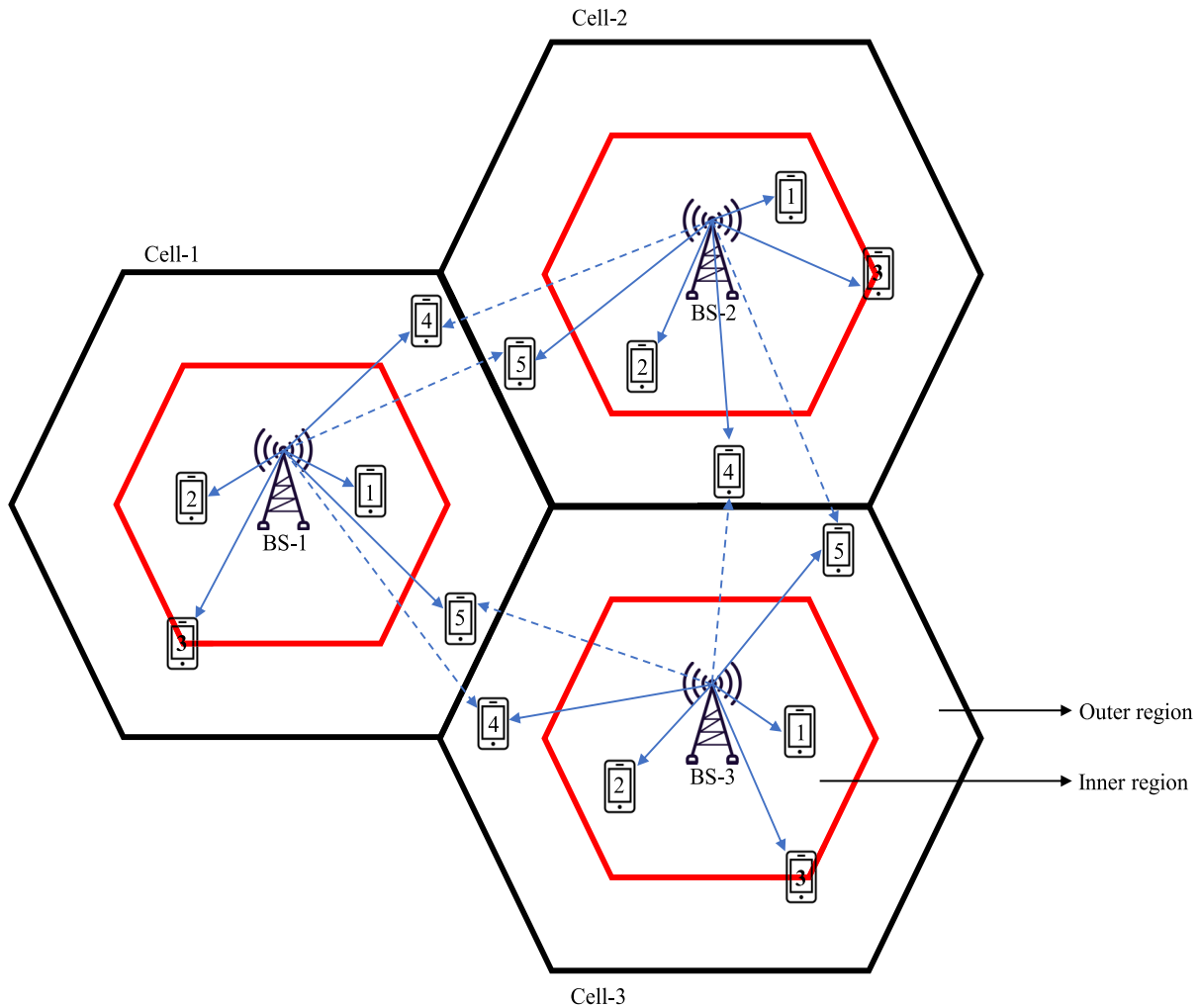

FIGURE 2. Multi-cellular MIMO network illustrating the CC, CM and CE users.

complexity and imposes much strain on backhaul links. Thus, in the proposed system model, only the cooperation among CE users is considered to enhance cost efficiency and facilitates the exchange of a massive amount of data. The cooperation of CE users with the adjacent CE users is considered, since  $SINR_C$  for the MIMO downlink Gaussian IC system will be reliant on the suggested CE users cooperation scheme. The equation below represents the capacity associated with the cooperative CE users:

$$C_C = \alpha \log_2(1 + \lambda SINR_C), \tag{3}$$

Here  $C_C$  signifies the capacity associated with the cooperative CE users and the proportion of resource sharing allocation between the cooperative CE users is defined by  $\alpha$ . Therefore, in the proposed system model, the resource fairness associated with the suggested method is defined when the value of  $\alpha = \frac{1}{2}$ . For an enhancement in SINR, cooperation between the CE users and the adjacent CE users needs to be considered. The accurate representation of the cooperative CE user scheme for the resource constraint to function well in

a downlink MIMO transmission strategy given by  $C_C > C_{NC}$  is as follows:

$$\begin{aligned} \frac{1}{2} \log_2(1 + \lambda SINR_C) &> \log_2(1 + \lambda SINR_{NC}), \\ \log_2(1 + \lambda SINR_C) &> \log_2(1 + \lambda SINR_{NC})^2, \\ (1 + \lambda SINR_C) &> 1^2 + (\lambda SINR_{NC})^2 + 2(\lambda SINR_{NC}), \\ (SINR_C) &> (\lambda SINR_{NC}^2 + 2SINR_{NC}). \end{aligned} \tag{4}$$

As a result, CE users should consider whether to use the cooperative downlink MIMO transmission technique between nearby CE users.

**D. FRACTIONAL FREQUENCY REUSE (FFR) AND SOFT FREQUENCY REUSE (SFR)**

The FFR and SFR approaches are two types of FR strategies that significantly enhance the spectral efficiency of the CE user by minimizing the ICI coordination. Also, these FFR and SFR approach partitions the cell into inner and outer zones or regions by employing a distinct FR factor. On the other hand, the distance present between the BS and the CE users



can result in diminished quality of service and poor channel conditions; to address these issues, CC, CM and CE user locations must be defined. The section below illustrates how to find the location of the user.

**E. DETERMINING THE USER LOCATION**

The stationary BS and the dynamic mobile users in the proposed system model use an efficient user pairing technique to select the optimum user pair based on identifying the user location. To determine the users location based on its position from BS, the median equation (5) is used. The users are classified into three primary groups: they are CC, CM and CE users, as depicted in figure 3. In the case of dynamic mobile users, the users are first separated by using the Euclidean norm and then using the median equation for the effective user pairing [37]; the available users are categorized into CC, CM and CE users. As a result, an effective user pairing is accomplished by selecting the best pair using the Euclidean norm and median equation. Also, out of the three categories of users, the CE users are affected by interference from the adjacent cells termed ICI. Thus, the equation below determines CM users:

$$CM\ Users = \frac{\|\hat{h}_{\frac{L}{2}}\| + \|\hat{h}_{\frac{L}{2}+1}\|}{2}. \tag{5}$$

The users having a value less than the value of the above equation are considered to be CC users and those users with a value greater than the value of the above equation are considered to be CE users. More precisely, the CC users (1,2), the CM users (3) and the CE users (4,5) are shown in figure 3.

**III. AN OUTDATED CSIT BASED RIA SCHEME**

This section illustrates an outdated CSIT-based RIA scheme for cooperative CE users in a multi-cellular MIMO IMAC and typifies the achievable sum DoF. The significance of outdated CSIT is that the already obtained overheard side information at the numerous receivers is utilized by the transmitters in such a way that it aids in creating upcoming transmissions that are concurrently beneficial for more than a receiver and can then be transmitted efficiently. Thus, from the motivation of RIA strategies in [9], [16], and [33], a transmission strategy consisting of three stages is proposed. That is, a tri-staged, outdated CSIT-based RIA scheme is proposed here. The three stages are as follows: stage 1 involves feeding the BS in cell-1 with the data streams from the cooperative CE users. During stage 2, the BS in cell-2 is fed with data streams from the cooperative CE users in cell-2. Finally, in stage 3, the overheard data streams (overheard undesired interference) received by the BS-C present in the cell in idle condition are redirected with the aid of outdated CSIT. On that account, overheard equation redirecting is performed at this stage. In the subsection that follows, by using the proposed tri-staged outdated CSIT-based RIA scheme, the sum of DoF attained by a three cooperative CE and an  $L$  cooperative CE multi-cellular MIMO IMAC is determined.

The figure 4 represents the step by step procedures involved in the proposed work.

**A. THREE COOPERATIVE CE MULTI-CELLULAR MIMO IMAC WITH OUTDATED CSIT BASED RIA SCHEME**

The application of the proposed outdated CSIT-based RIA scheme to a multi-cellular MIMO IMAC with three antennas equipped at each BS, two antennas each equipped at the three cooperative CE users denoted by (3,2,3) is illustrated and determines the achievable DoF of the same as  $\frac{24}{7}$ . Subsequently, this section illustrates how  $\frac{24}{7}$  DoF is attained by successfully transmitting all the twenty-four desired interference-free symbols over the seven-time slots. The proposed transmission scheme illustrating all the three stages is detailed further below:

**Stage-1:** This stage is characterized by three-time slots. The cooperative CE users in cell 1, denoted by [1,1], [2,1] and [3,1], transmit the information symbols as shown below:

$$T_x^{[1,1]}(1) = \begin{bmatrix} w_1^{[1]} \\ w_2^{[1]} \end{bmatrix}, \quad T_x^{[1,1]}(2) = \begin{bmatrix} w_3^{[1]} \\ 0 \end{bmatrix},$$

$$T_x^{[1,1]}(3) = \begin{bmatrix} w_4^{[1]} \\ 0 \end{bmatrix}, \tag{6}$$

$$T_x^{[2,1]}(1) = \begin{bmatrix} w_1^{[2]} \\ 0 \end{bmatrix}, \quad T_x^{[2,1]}(2) = \begin{bmatrix} w_2^{[2]} \\ w_3^{[2]} \end{bmatrix},$$

$$T_x^{[2,1]}(3) = \begin{bmatrix} w_4^{[2]} \\ 0 \end{bmatrix}, \tag{7}$$

$$T_x^{[3,1]}(1) = \begin{bmatrix} w_1^{[3]} \\ 0 \end{bmatrix}, \quad T_x^{[3,1]}(2) = \begin{bmatrix} w_2^{[3]} \\ 0 \end{bmatrix},$$

$$T_x^{[3,1]}(3) = \begin{bmatrix} w_3^{[3]} \\ w_4^{[3]} \end{bmatrix}. \tag{8}$$

Thus, stage-1 is exclusively dedicated to the cooperative CE users belonging to cell 1 and the signal received by the receiver (BS-1) in this stage for the  $t^{th}$  time slot is given by the equation below:

$$R_x^{[1]}(t) = \sum_{b=1}^3 H_1^{[b,1]}(t) \times T_x^{[b,1]}(t) + n^{[1]}(t), \tag{9}$$

Thus, by expanding the above equation, the received signal at the BS-1 for the  $t^{th}$  time slot is denoted by:

$$R_x^{[1]}(t) = H_1^{[1,1]}(t) \times T_x^{[1,1]}(t) + H_1^{[2,1]}(t) \times T_x^{[2,1]}(t) + H_1^{[3,1]}(t) \times T_x^{[3,1]}(t) + n^{[1]}(t), \tag{10}$$

For the first time slot, the received signals at the BS-1 is denoted as follows:

$$R_x^{[1]}(1) = H_1^{[1,1]}(1) \times T_x^{[1,1]}(1) + H_1^{[2,1]}(1) \times T_x^{[2,1]}(1) + H_1^{[3,1]}(1) \times T_x^{[3,1]}(1) + n^{[1]}(1), \tag{11}$$

Similarly, for the time slot  $t \in [2,3]$ , the received signals at the BS-1 follows that of equation (10) with the value of  $t$  changing to 2 and 3 respectively. Also, the same information

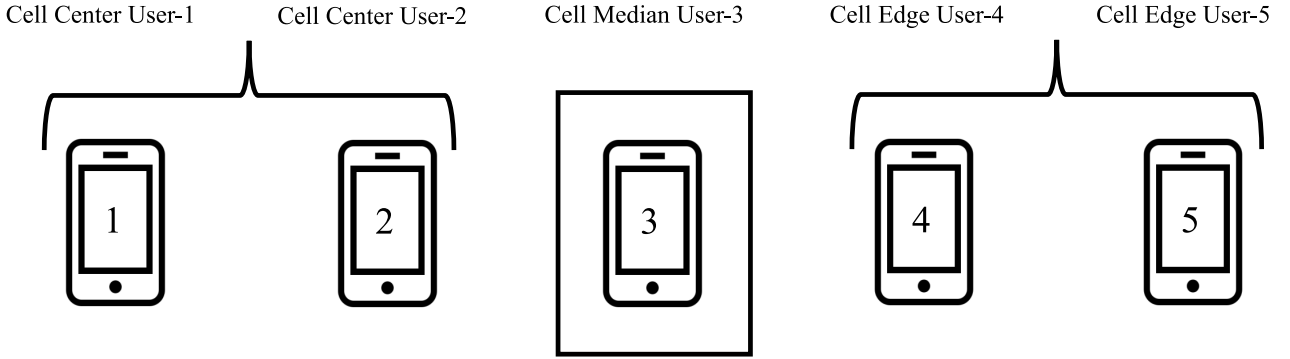

FIGURE 3. Determining the position of the user based on its distance from the BS.

symbols from the cooperative CE users in cell-1 are overheard by the BS-C. Thus, the received signals at the BS-C are denoted by the following equations:

$$R_x^{[C]}(t) = \sum_{b=1}^3 H_C^{[b,1]}(t) \times T_x^{[b,1]}(t) + n^{[C]}(t), \quad (12)$$

Thus, by expanding the above equation, the received signal at the BS-C for the  $t^{\text{th}}$  time slot is denoted by:

$$R_x^{[C]}(t) = H_C^{[1,1]}(t) \times T_x^{[1,1]}(t) + H_C^{[2,1]}(t) \times T_x^{[2,1]}(t) + H_C^{[3,1]}(t) \times T_x^{[3,1]}(t) + n^{[C]}(t), \quad (13)$$

For the first time slot, the received signals at the BS-C are denoted as follows:

$$R_x^{[C]}(1) = H_C^{[1,1]}(1) \times T_x^{[1,1]}(1) + H_C^{[2,1]}(1) \times T_x^{[2,1]}(1) + H_C^{[3,1]}(1) \times T_x^{[3,1]}(1) + n^{[C]}(1), \quad (14)$$

Similarly, for the time slot  $t \in [2,3]$ , the resulting equation follows that of (13) where the value of  $t$  changes to 2 and 3 respectively. The shorthand representation of the desired and the overheard signals by the BS-1 and BS-C, in stage-1 is represented by the following equations:

$$S_1^{[1]}(w_1^{[1]}, w_2^{[1]}, w_1^{[2]}, w_1^{[3]}) = H_1^{[1,1]}(1) \times T_x^{[1,1]}(1) + H_1^{[2,1]}(1) \times T_x^{[2,1]}(1) + H_1^{[3,1]}(1) \times T_x^{[3,1]}(1), \quad (15)$$

$$S_2^{[1]}(w_3^{[1]}, w_2^{[2]}, w_3^{[2]}, w_2^{[3]}) = H_1^{[1,1]}(2) \times T_x^{[1,1]}(2) + H_1^{[2,1]}(2) \times T_x^{[2,1]}(2) + H_1^{[3,1]}(2) \times T_x^{[3,1]}(2), \quad (16)$$

$$S_3^{[1]}(w_4^{[1]}, w_4^{[2]}, w_3^{[3]}, w_4^{[3]}) = H_1^{[1,1]}(3) \times T_x^{[1,1]}(3) + H_1^{[2,1]}(3) \times T_x^{[2,1]}(3) + H_1^{[3,1]}(3) \times T_x^{[3,1]}(3), \quad (17)$$

$$S_1^{[C]}(w_1^{[1]}, w_2^{[1]}, w_1^{[2]}, w_1^{[3]}) = H_C^{[1,1]}(1) \times T_x^{[1,1]}(1) + H_C^{[2,1]}(1) \times T_x^{[2,1]}(1) + H_C^{[3,1]}(1) \times T_x^{[3,1]}(1), \quad (18)$$

$$S_2^{[C]}(w_3^{[1]}, w_2^{[2]}, w_3^{[2]}, w_2^{[3]}) = H_C^{[1,1]}(2) \times T_x^{[1,1]}(2)$$

$$+ H_C^{[2,1]}(2) \times T_x^{[2,1]}(2) + H_C^{[3,1]}(2) \times T_x^{[3,1]}(2), \quad (19)$$

$$S_3^{[C]}(w_4^{[1]}, w_4^{[2]}, w_3^{[3]}, w_4^{[3]}) = H_C^{[1,1]}(3) \times T_x^{[1,1]}(3) + H_C^{[2,1]}(3) \times T_x^{[2,1]}(3) + H_C^{[3,1]}(3) \times T_x^{[3,1]}(3). \quad (20)$$

In the shorthand representation above, the noise terms are not considered as they do not have any impact on the DoF characterization at high SNR regimes. The overheard equation vectors that transmit information intended to BS-1 are stored in the BS-C. These overheard equation vectors stored in BS-C will be utilized later in stage-3.

**Stage-2:** This stage is also characterized by three-time slots. The cooperative CE users in cell 2, denoted by [1,2], [2,2] and [3,2], transmit the information symbols as shown below:

$$T_x^{[1,2]}(4) = \begin{bmatrix} x_1^{[1]} \\ x_2^{[1]} \end{bmatrix}, \quad T_x^{[1,2]}(5) = \begin{bmatrix} x_3^{[1]} \\ 0 \end{bmatrix}, \quad T_x^{[1,2]}(6) = \begin{bmatrix} x_4^{[1]} \\ 0 \end{bmatrix}, \quad (21)$$

$$T_x^{[2,2]}(4) = \begin{bmatrix} x_1^{[2]} \\ 0 \end{bmatrix}, \quad T_x^{[2,2]}(5) = \begin{bmatrix} x_2^{[2]} \\ x_3^{[2]} \end{bmatrix}, \quad T_x^{[2,2]}(6) = \begin{bmatrix} x_4^{[2]} \\ 0 \end{bmatrix}, \quad (22)$$

$$T_x^{[3,2]}(4) = \begin{bmatrix} x_1^{[3]} \\ 0 \end{bmatrix}, \quad T_x^{[3,2]}(5) = \begin{bmatrix} x_2^{[3]} \\ 0 \end{bmatrix}, \quad T_x^{[3,2]}(6) = \begin{bmatrix} x_3^{[3]} \\ x_4^{[3]} \end{bmatrix}. \quad (23)$$

Thus, stage-2 is exclusively dedicated to the CE users belonging to cell 2 and the signal received by the receiver (BS-2) in this stage for the  $t^{\text{th}}$  time slot is given by the equation below:

$$R_x^{[2]}(t) = \sum_{b=1}^3 H_2^{[b,2]}(t) \times T_x^{[b,2]}(t) + n^{[2]}(t), \quad (24)$$

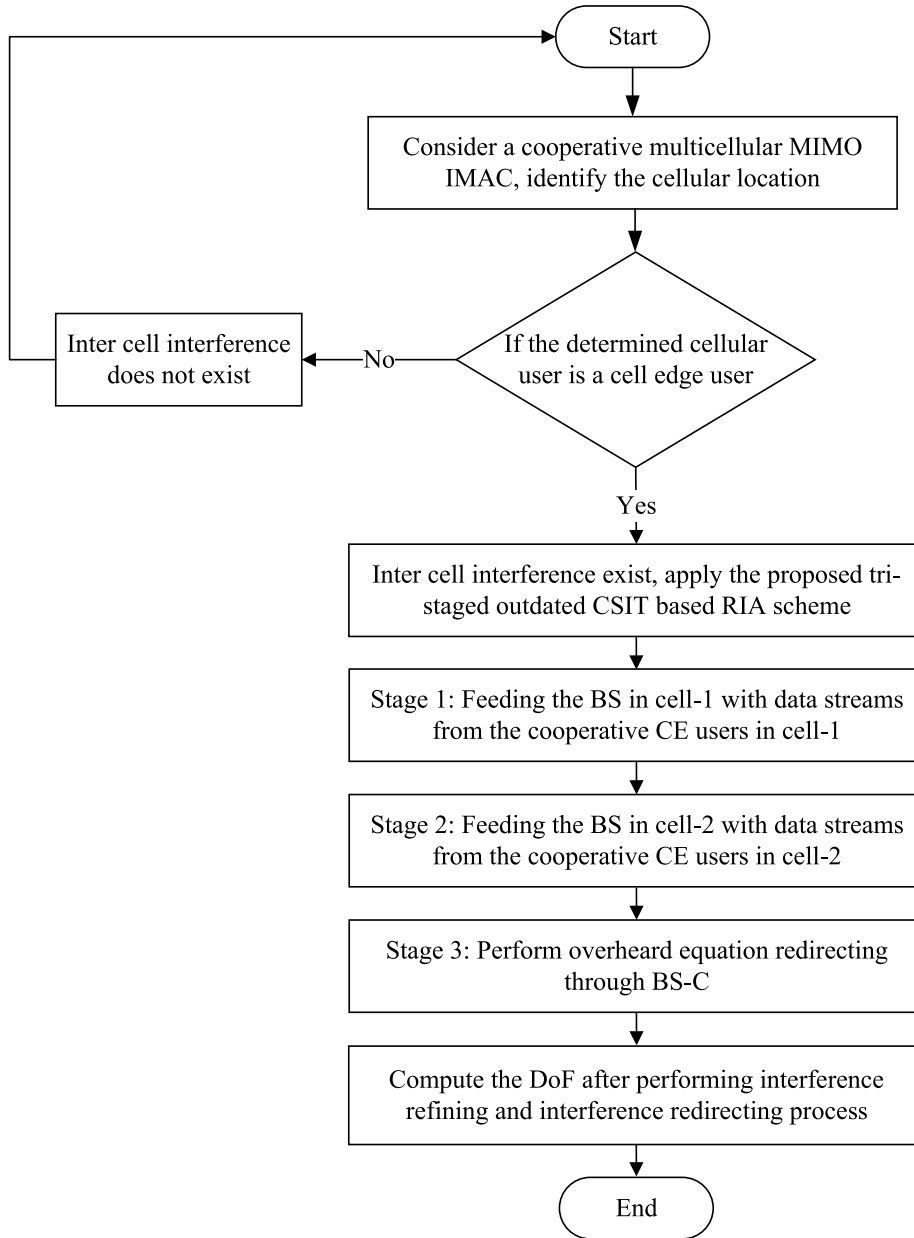

FIGURE 4. Step-by-step procedures involved in the proposed work.

Thus, by expanding the above equation, the received signal at the BS-2 for the  $t^{\text{th}}$  time slot is denoted by:

$$R_x^{[2]}(t) = H_2^{[1,2]}(t) \times T_x^{[1,2]}(t) + H_2^{[2,2]}(t) \times T_x^{[2,2]}(t) + H_2^{[3,2]}(t) \times T_x^{[3,2]}(t) + n^{[2]}(t), \quad (25)$$

For the fourth time slot, the received signals at the BS-2 are denoted as follows:

$$R_x^{[2]}(4) = H_2^{[1,2]}(4) \times T_x^{[1,2]}(4) + H_2^{[2,2]}(4) \times T_x^{[2,2]}(4) + H_2^{[3,2]}(4) \times T_x^{[3,2]}(4) + n^{[2]}(4), \quad (26)$$

Similarly, for the time slot  $t \in [5,6]$ , the resulting equation follows that of (25) where the value of  $t$  changes to 5 and

6 respectively. Also, the BS-C overhears the same information symbols from the cooperative CE users in cell-2. Thus, the received signals at the BS-C are denoted by the following equations:

$$R_x^{[C]}(t) = \sum_{b=1}^3 H_C^{[b,2]}(t) \times T_x^{[b,2]}(t) + n^{[C]}(t), \quad (27)$$

Thus, by expanding the above equation, the received signal at the BS-C for the  $t^{\text{th}}$  time slot is denoted by:

$$R_x^{[C]}(t) = H_C^{[1,2]}(t) \times T_x^{[1,2]}(t) + H_C^{[2,2]}(t) \times T_x^{[2,2]}(t) + H_C^{[3,2]}(t) \times T_x^{[3,2]}(t) + n^{[C]}(t), \quad (28)$$



For the time slot  $t \in [4,5,6]$ , the received signals at the BS-C are denoted as follows:

$$\begin{aligned} \text{Rx}^{[C]}(4) &= \text{H}_C^{[1,2]}(4) \times \text{Tx}^{[1,2]}(4) + \text{H}_C^{[2,2]}(4) \times \text{Tx}^{[2,2]}(4) \\ &\quad + \text{H}_C^{[3,2]}(4) \times \text{Tx}^{[3,2]}(4) + \text{n}^{[C]}(4), \end{aligned} \quad (29)$$

$$\begin{aligned} \text{Rx}^{[C]}(5) &= \text{H}_C^{[1,2]}(5) \times \text{Tx}^{[1,2]}(5) + \text{H}_C^{[2,2]}(5) \times \text{Tx}^{[2,2]}(5) \\ &\quad + \text{H}_C^{[3,2]}(5) \times \text{Tx}^{[3,2]}(5) + \text{n}^{[C]}(5), \end{aligned} \quad (30)$$

$$\begin{aligned} \text{Rx}^{[C]}(6) &= \text{H}_C^{[1,2]}(6) \times \text{Tx}^{[1,2]}(6) + \text{H}_C^{[2,2]}(6) \times \text{Tx}^{[2,2]}(6) \\ &\quad + \text{H}_C^{[3,2]}(6) \times \text{Tx}^{[3,2]}(6) + \text{n}^{[C]}(6). \end{aligned} \quad (31)$$

The shorthand representation of desired and overheard signals by the BS-2 and BS-C, in stage-2 is represented by the following equations:

$$\begin{aligned} \text{S}_4^{[2]}(x_1^{[1]}, x_2^{[1]}, x_1^{[2]}, x_1^{[3]}) &= \text{H}_2^{[1,2]}(4) \times \text{Tx}^{[1,2]}(4) \\ &\quad + \text{H}_2^{[2,2]}(4) \times \text{Tx}^{[2,2]}(4) \\ &\quad + \text{H}_2^{[3,2]}(4) \times \text{Tx}^{[3,2]}(4), \end{aligned} \quad (32)$$

$$\begin{aligned} \text{S}_5^{[2]}(x_3^{[1]}, x_2^{[2]}, x_3^{[2]}, x_2^{[3]}) &= \text{H}_2^{[1,2]}(5) \times \text{Tx}^{[1,2]}(5) \\ &\quad + \text{H}_2^{[2,2]}(5) \times \text{Tx}^{[2,2]}(5) \\ &\quad + \text{H}_2^{[3,2]}(5) \times \text{Tx}^{[3,2]}(5), \end{aligned} \quad (33)$$

$$\begin{aligned} \text{S}_6^{[2]}(x_4^{[1]}, x_4^{[2]}, x_3^{[3]}, x_4^{[3]}) &= \text{H}_2^{[1,2]}(6) \times \text{Tx}^{[1,2]}(6) \\ &\quad + \text{H}_2^{[2,2]}(6) \times \text{Tx}^{[2,2]}(6) \\ &\quad + \text{H}_2^{[3,2]}(6) \times \text{Tx}^{[3,2]}(6), \end{aligned} \quad (34)$$

$$\begin{aligned} \text{S}_4^{[C]}(x_1^{[1]}, x_2^{[1]}, x_1^{[2]}, x_1^{[3]}) &= \text{H}_C^{[1,2]}(4) \times \text{Tx}^{[1,2]}(4) \\ &\quad + \text{H}_C^{[2,2]}(4) \times \text{Tx}^{[2,2]}(4) \\ &\quad + \text{H}_C^{[3,2]}(4) \times \text{Tx}^{[3,2]}(4), \end{aligned} \quad (35)$$

$$\begin{aligned} \text{S}_5^{[C]}(x_3^{[1]}, x_2^{[2]}, x_3^{[2]}, x_2^{[3]}) &= \text{H}_C^{[1,2]}(5) \times \text{Tx}^{[1,2]}(5) \\ &\quad + \text{H}_C^{[2,2]}(5) \times \text{Tx}^{[2,2]}(5) \\ &\quad + \text{H}_C^{[3,2]}(5) \times \text{Tx}^{[3,2]}(5), \end{aligned} \quad (36)$$

$$\begin{aligned} \text{S}_6^{[C]}(x_4^{[1]}, x_4^{[2]}, x_3^{[3]}, x_4^{[3]}) &= \text{H}_C^{[1,2]}(6) \times \text{Tx}^{[1,2]}(6) \\ &\quad + \text{H}_C^{[2,2]}(6) \times \text{Tx}^{[2,2]}(6) \\ &\quad + \text{H}_C^{[3,2]}(6) \times \text{Tx}^{[3,2]}(6). \end{aligned} \quad (37)$$

In the shorthand representation above, the noise terms are not considered as they do not have any impact on the DoF characterization at high SNR regimes. The overheard equation vectors that transmit information intended to BS-2 are stored in the BS-C. These overheard equation vectors stored in BS-C will be utilized later in stage-3.

The key point to be noted at the conclusion of stage 1 is that the BS-1 is characterized by nine linearly independent equations with twelve desired symbols; thus, an additional three more linear independent equations are needed to resolve the desired symbols. These additional three linear independent equations are obtained from the BS-C. As BS-C possesses a total of eighteen overheard linear independent equations, none of which pertains to BS-C but rather to BS-1 (nine overheard linear independent equations can be utilized by BS-1) and BS-2 (nine overheard linear independent equations can be utilized by BS-2). Similarly, the BS-2 is also deficit by

three independent linear equations. This insufficiency of the three linear independent equations is handled by the BS-C that received extra overheard equations during stage-2. Subsequently, the outdated CSIT based RIA scheme is utilized at the initial stage where the overheard linear independent equations need to be refined by using appropriate linear combinations, resulting in three new linear independent equations per cell that are purely in terms of one transmitters information symbol. Thus the equations overheard by the BS-C during stage-1 are modified (interference refined) and is used in BS-2. Therefore, to apply RIA in the upcoming stage-3, BS-C eliminates  $(w_1^{[2]}, w_1^{[3]})$ ,  $(w_3^{[1]}, w_2^{[3]})$  and  $(w_4^{[1]}, w_4^{[2]})$  symbols from the overheard received signal vectors during time slots 1, 2 and 3, respectively. Therefore, the modified (interference refined) overheard equations illustrating the same for  $1 \leq t \leq 3$  are as shown below:

$$\hat{\text{S}}_1^{[C]}(w_1^{[1]}, w_2^{[1]}) = \text{W}_1^{[1]\dagger} \text{S}_1^{[C]}(w_1^{[1]}, w_2^{[1]}, w_1^{[2]}, w_1^{[3]}), \quad (38)$$

$$\hat{\text{S}}_2^{[C]}(w_2^{[2]}, w_3^{[2]}) = \text{W}_2^{[1]\dagger} \text{S}_2^{[C]}(w_3^{[1]}, w_2^{[2]}, w_3^{[2]}, w_2^{[3]}), \quad (39)$$

$$\hat{\text{S}}_3^{[C]}(w_3^{[3]}, w_4^{[3]}) = \text{W}_3^{[1]\dagger} \text{S}_3^{[C]}(w_4^{[1]}, w_4^{[2]}, w_3^{[3]}, w_4^{[3]}), \quad (40)$$

Here,  $\text{W}_t^{[1]\dagger}$  denotes the conjugate transpose of the combining vector of order  $N \times 1$  for the equations overheard at time slot  $1 \leq t \leq 3$  during the stage-1.  $\hat{\text{S}}_t^{[C]}(w_t^{[t]}, w_{t+1}^{[t]})$  wherein  $t \in \{1, 2, 3\}$  denotes the newly formed linear equation that purely consists of symbols sent by a single transmitter, enabling them to be locally created with delayed CSIT at that transmitter, this method is termed interference refining. Furthermore, the combining vector  $\text{W}_t^{[1]\dagger}$  must meet the following criteria:

$$\text{W}_t^{[1]\dagger} \times \text{H}_C^{[\bar{t},1]}(t) \times \text{Tx}^{[\bar{t},1]}(t) = 0, \quad \forall t, \bar{t} \in \{1, 2, 3\}, \bar{t} \neq t. \quad (41)$$

Similarly, the equations overheard by the BS-C during stage-2 are modified and used in BS-1. Consequently, to apply RIA in the upcoming stage-3, BS-C eliminates  $(x_1^{[2]}, x_1^{[3]})$ ,  $(x_3^{[1]}, x_2^{[3]})$  and  $(x_4^{[1]}, x_4^{[2]})$  symbols from the overheard received signal vectors during time slots 4, 5 and 6 respectively. Therefore, the modified overheard equations illustrating the same for  $4 \leq t \leq 6$  are as shown below:

$$\hat{\text{S}}_4^{[C]}(x_1^{[1]}, x_2^{[1]}) = \text{W}_4^{[2]\dagger} \text{S}_4^{[C]}(x_1^{[1]}, x_2^{[1]}, x_1^{[2]}, x_1^{[3]}), \quad (42)$$

$$\hat{\text{S}}_5^{[C]}(x_2^{[2]}, x_3^{[2]}) = \text{W}_5^{[2]\dagger} \text{S}_5^{[C]}(x_3^{[1]}, x_2^{[2]}, x_3^{[2]}, x_2^{[3]}), \quad (43)$$

$$\hat{\text{S}}_6^{[C]}(x_3^{[3]}, x_4^{[3]}) = \text{W}_6^{[2]\dagger} \text{S}_6^{[C]}(x_4^{[1]}, x_4^{[2]}, x_3^{[3]}, x_4^{[3]}), \quad (44)$$

Here,  $\text{W}_t^{[2]\dagger}$  denotes the conjugate transpose of the combining vector of the order  $N \times 1$  for the equations overheard at time slot  $4 \leq t \leq 6$  during the stage-2. Also, the combining vector  $\text{W}_t^{[2]\dagger}$  must meet the following criteria:

$$\text{W}_t^{[2]\dagger} \times \text{H}_C^{[\bar{t},2]}(t) \times \text{Tx}^{[\bar{t},2]}(t) = 0, \quad \forall t, \bar{t} \in \{4, 5, 6\}, \bar{t} \neq t. \quad (45)$$

It is observed that the  $\text{Tx}^{[\bar{t},1]}(t)$  is a  $2 \times 1$  vector with a single non-zero entry. Thus,  $\text{H}_2^{[\bar{t},1]}(t) \times \text{Tx}^{[\bar{t},1]}(t)$  is effectually a

$3 \times 1$  matrix, specifying the occurrence of  $W_i^{[1]\dagger}$  by employing the linear algebras rank nullity theorem. Also, it can be concluded that without the interference refining process, the individual transmitters (cooperative CE users) are unable to provide the locally created delayed CSIT linear equation. Thus the purpose of stage-3 is to redirect the refined overheard equations from the BS-C to the intended BS's (i.e., BS-1 and BS-2). In other words, the three overheard independent linear equations from BS-C are refined overheard equations denoted by  $\hat{S}_1^{[C]}(w_1^{[1]}, w_2^{[1]})$ ,  $\hat{S}_2^{[C]}(w_2^{[2]}, w_3^{[2]})$  and  $\hat{S}_3^{[C]}(w_3^{[3]}, w_4^{[3]})$  are redirected to BS-2, which makes a total of twelve independent linear equations with twelve desired symbols that make it resolvable. Similarly, the remaining three overheard linear independent equations from BS-C are redirected to the BS-1. That is, the refined overheard equations denoted by  $\hat{S}_4^{[C]}(x_1^{[1]}, x_2^{[1]})$ ,  $\hat{S}_5^{[C]}(x_2^{[2]}, x_3^{[2]})$  and  $\hat{S}_6^{[C]}(x_3^{[3]}, x_4^{[3]})$  from the BS-C are redirected to BS-1. As a result, in stage-3, each transmitter reconstructs the subsequently transmitted signals using the delayed CSIT and previously sent symbols.

**Stage-3:** This stage functions in a time slot 7, where each transmitter has the knowledge of CSI from the previous time slots. Thus, by making use of the delayed CSIT, the individual transmitter can reassemble the extra linear equations created at the end of the stage-2 depending on the interfering BSs overheard equation vectors. This stage is also called as interference redirecting term, and this information symbols are conveyed as follows:

$$\begin{aligned} T_X^{[1,1]}(7) &= \begin{bmatrix} \hat{S}_1^{[C]}(w_1^{[1]}, w_2^{[1]}) \\ 0 \end{bmatrix}, \\ T_X^{[2,1]}(7) &= \begin{bmatrix} \hat{S}_2^{[C]}(w_2^{[2]}, w_3^{[2]}) \\ 0 \end{bmatrix}, \\ T_X^{[3,1]}(7) &= \begin{bmatrix} \hat{S}_3^{[C]}(w_3^{[3]}, w_4^{[3]}) \\ 0 \end{bmatrix}, \end{aligned} \tag{46}$$

$$\begin{aligned} T_X^{[1,2]}(7) &= \begin{bmatrix} \hat{S}_4^{[C]}(x_1^{[1]}, x_2^{[1]}) \\ 0 \end{bmatrix}, \\ T_X^{[2,2]}(7) &= \begin{bmatrix} \hat{S}_5^{[C]}(x_2^{[2]}, x_3^{[2]}) \\ 0 \end{bmatrix}, \\ T_X^{[3,2]}(7) &= \begin{bmatrix} \hat{S}_6^{[C]}(x_3^{[3]}, x_4^{[3]}) \\ 0 \end{bmatrix}. \end{aligned} \tag{47}$$

The signals received at the BS-C from the transmitters present in the cell-1 and cell-2 are depicted below:

$$\begin{aligned} R_X^{[C,1]}(7) &= h_{C1}^{[1,1]}(7) \times \hat{S}_1^c(w_1^{[1]}, w_2^{[1]}) + h_{C1}^{[2,1]}(7) \\ &\quad \times \hat{S}_2^c(w_2^{[2]}, w_3^{[2]}) + h_{C1}^{[3,1]}(7) \\ &\quad \times \hat{S}_3^c(w_3^{[3]}, w_4^{[3]}) + n^{[C]}(7), \end{aligned} \tag{48}$$

$$\begin{aligned} R_X^{[C,2]}(7) &= h_{C1}^{[1,2]}(7) \times \hat{S}_4^c(x_1^{[1]}, x_2^{[1]}) + h_{C1}^{[2,2]}(7) \\ &\quad \times \hat{S}_5^c(x_2^{[2]}, x_3^{[2]}) + h_{C1}^{[3,2]}(7) \\ &\quad \times \hat{S}_6^c(x_3^{[3]}, x_4^{[3]}) + n^{[C]}(7). \end{aligned} \tag{49}$$

The signals received by the BS-1, BS-2 from the transmitters present in the cell-1 and cell-2 are depicted below:

$$\begin{aligned} R_X^{[1]}(7) &= h_{11}^{[1,1]}(7) \times \hat{S}_1^c(w_1^{[1]}, w_2^{[1]}) \\ &\quad + h_{11}^{[2,1]}(7) \times \hat{S}_2^c(w_2^{[2]}, w_3^{[2]}) \\ &\quad + h_{11}^{[3,1]}(7) \times \hat{S}_3^c(w_3^{[3]}, w_4^{[3]}) + n^{[1]}(7), \end{aligned} \tag{50}$$

$$\begin{aligned} R_X^{[2]}(7) &= h_{21}^{[1,2]}(7) \times \hat{S}_4^c(x_1^{[1]}, x_2^{[1]}) \\ &\quad + h_{21}^{[2,2]}(7) \times \hat{S}_5^c(x_2^{[2]}, x_3^{[2]}) \\ &\quad + h_{21}^{[3,2]}(7) \times \hat{S}_6^c(x_3^{[3]}, x_4^{[3]}) + n^{[2]}(7). \end{aligned} \tag{51}$$

Therefore the total received signal is calculated by summing up the intended redirected signal from the BS-C and the BSs of the individual cell-1 (BS-1) and cell-2 (BS-2) are as follows:

$$\begin{aligned} R_X^{[C,2]}(7) + R_X^{[1]}(7) &= h_{C1}^{[1,2]}(7) \times \hat{S}_4^c(x_1^{[1]}, x_2^{[1]}) \\ &\quad + h_{C1}^{[2,2]}(7) \times \hat{S}_5^c(x_2^{[2]}, x_3^{[2]}) \\ &\quad + h_{C1}^{[3,2]}(7) \times \hat{S}_6^c(x_3^{[3]}, x_4^{[3]}) \\ &\quad + h_{11}^{[1,1]}(7) \times \hat{S}_1^c(w_1^{[1]}, w_2^{[1]}) \\ &\quad + h_{11}^{[2,1]}(7) \times \hat{S}_2^c(w_2^{[2]}, w_3^{[2]}) \\ &\quad + h_{11}^{[3,1]}(7) \times \hat{S}_3^c(w_3^{[3]}, w_4^{[3]}) \\ &\quad + n^{[1]}(7) + n^{[C]}(7) \end{aligned} \tag{52}$$

$$\begin{aligned} R_X^{[C,1]}(7) + R_X^{[2]}(7) &= h_{C1}^{[1,1]}(7) \times \hat{S}_1^c(w_1^{[1]}, w_2^{[1]}) \\ &\quad + h_{C1}^{[2,1]}(7) \times \hat{S}_2^c(w_2^{[2]}, w_3^{[2]}) \\ &\quad + h_{C1}^{[3,1]}(7) \times \hat{S}_3^c(w_3^{[3]}, w_4^{[3]}) \\ &\quad + h_{21}^{[1,2]}(7) \times \hat{S}_4^c(x_1^{[1]}, x_2^{[1]}) \\ &\quad + h_{21}^{[2,2]}(7) \times \hat{S}_5^c(x_2^{[2]}, x_3^{[2]}) \\ &\quad + h_{21}^{[3,2]}(7) \times \hat{S}_6^c(x_3^{[3]}, x_4^{[3]}) \\ &\quad + n^{[C]}(7) + n^{[2]}(7) \end{aligned} \tag{53}$$

Here,  $h_{a,b}^{[l,k]}(t)$  is the  $b^{\text{th}}$  column of  $H_a^{[l,k]}(t)$ . Therefore, it can be noted that utilizing the entire time slots  $1 \leq t \leq 7$ , the transmitted signals are completely designed in the proposed network. The equation (54), as shown at the bottom of the next page, represents the combined received signals of BS-1 and BS-C during stages 1,2 and 3.

In equation (54),  $\Gamma_b^{[a]}$  represents  $h_{1,1}^{\text{mod}(b-1,2)+1,a]}(7) \times W_b^{[a]\dagger} \forall a, a \neq \bar{a}$  where  $\bar{a} \in \{1, 2, 3\}$ . It is visible that after multiplying  $\Gamma_4^{[2]}$  by  $R_X^{[C]}(4)$ , the interference signals  $x_1^{[1]}$  and  $x_2^{[1]}$  are aligned at the received signal from the same direction  $[0, 0, 0, (\Gamma_4^{[2]}h_{C1}^{[1,2]}(4))^T, 0, 0, (\Gamma_4^{[2]}h_{C1}^{[1,2]}(4))^T]^T$  at BS-C. Likewise, the symbols  $(x_2^{[2]}, x_3^{[2]})$  and  $(x_3^{[3]}, x_4^{[3]})$  are also aligned by applying the combiner  $\Gamma_5^{[2]}$  with  $R_X^{[C]}(5)$  and  $\Gamma_6^{[2]}$  with  $R_X^{[C]}(6)$ . Subsequently, to eliminate the ICI at the BS-C, the following steps need to be performed: firstly, the received signals  $R_X^{[C]}(4)$ ,  $R_X^{[C]}(5)$  and  $R_X^{[C]}(6)$  need to be multiplied with the combiners  $\Gamma_4^{[2]}$ ,  $\Gamma_5^{[2]}$  and  $\Gamma_6^{[2]}$ , respectively.

The summation of the resultant is considered and subtracted from the signals received at the seventh time slot denoted by  $Rx^{[C, 2]}(7) + Rx^{[1]}(7)$  are depicted in (55), as shown at the bottom of the next page.

In addition, the equation (55) concludes that as all the channel values are generic, the three-channel matrices above are linearly independent and will have a probability of 1. Thus, by completely eliminating the corresponding inter-user interference, each receiver can successfully decode the twelve data symbols of  $w_i^{[1]}$ ,  $w_i^{[2]}$ ,  $w_i^{[3]}$  and  $x_i^{[1]}$ ,  $x_i^{[2]}$ ,  $x_i^{[3]}$   $i \in \{1, 2, 3, 4\}$  specified for BS-1 and BS-2 respectively. The equation (56), as shown at the bottom of the next page, denote the successfully decoded twelve data symbols meant for BS-2.

Thus it can be concluded that a total of  $\frac{24}{7}$  DoF (i.e.,  $\frac{12}{7}$  DoF of BS-1 and  $\frac{12}{7}$  DoF of BS-2) is attained by the three cooperative CE user multi-cellular MIMO IMAC.

#### IV. L COOPERATIVE CE MULTI-CELLULAR MIMO IMAC WITH OUTDATED CSIT BASED RIA SCHEME

This section illustrates the application of the proposed outdated CSIT-based RIA scheme to a multi-cellular MIMO

IMAC with  $L$  antennas equipped at each BS, two antennas each equipped at the  $L$  cooperative CE users denoted by  $(L, 2, L)$  and determines the desired DoF of the same as  $\frac{2L(L+1)}{2L+1}$ . The algorithm 1 demonstrates the proposed tristaged RIA scheme for the  $L$  cooperative CE multicellular MIMO IMAC. The proposed transmission scheme illustrating all the three stages is detailed below:

**Stage-1:** This stage is characterized by  $L$  time slots and is intended for the cooperative CE users belonging to cell-1.

$$Tx^{[b, 1]}(t) = \begin{cases} \begin{bmatrix} w_t^{[b]} \\ 0 \end{bmatrix} & \text{for } (t < b), \\ \begin{bmatrix} w_t^{[b]} \\ w_{t+1}^{[b]} \end{bmatrix} & \text{for } (t = b), \\ \begin{bmatrix} w_{t+1}^{[b]} \\ 0 \end{bmatrix} & \text{for } (t > b), \end{cases} \quad (57)$$

Here  $1 \leq t \leq L$ ,  $t$  represents the time slot,  $[b, a]$  denotes the  $b^{\text{th}}$  user in the  $a^{\text{th}}$  cell and  $w_k^{[b]}$  denotes the  $k^{\text{th}}$  information symbol for the  $b^{\text{th}}$  user in the BS-1. The signal received by the receiver (BS-1) in this stage for the  $t^{\text{th}}$  time slot is given

$$\begin{aligned} & \begin{bmatrix} Rx^{[1]}(1) \\ Rx^{[1]}(2) \\ Rx^{[1]}(3) \\ Rx^{[C]}(4) \\ Rx^{[C]}(5) \\ Rx^{[C]}(6) \\ Rx^{[C, 2]}(7) + Rx^{[1]}(7) \end{bmatrix} = \begin{bmatrix} h_{11}^{[1, 1]}(1) & h_{12}^{[1, 1]}(1) & 0 & 0 \\ 0 & 0 & h_{11}^{[1, 1]}(2) & 0 \\ 0 & 0 & 0 & h_{11}^{[1, 1]}(3) \\ 0 & 0 & 0 & 0 \\ 0 & 0 & 0 & 0 \\ 0 & 0 & 0 & 0 \\ \Gamma_1^{[1]} h_{11}^{[1, 1]}(1) & \Gamma_1^{[1]} h_{12}^{[1, 1]}(1) & 0 & 0 \end{bmatrix} \begin{bmatrix} w_1^{[1]} \\ w_2^{[1]} \\ w_3^{[1]} \\ w_4^{[1]} \end{bmatrix} \\ + & \begin{bmatrix} h_{11}^{[2, 1]}(1) & 0 & 0 & 0 \\ 0 & h_{11}^{[2, 1]}(2) & h_{12}^{[2, 1]}(2) & 0 \\ 0 & 0 & 0 & h_{11}^{[3, 1]}(3) \\ 0 & 0 & 0 & 0 \\ 0 & 0 & 0 & 0 \\ 0 & 0 & 0 & 0 \\ 0 & \Gamma_2^{[1]} h_{11}^{[2, 1]}(2) & \Gamma_2^{[1]} h_{12}^{[1, 1]}(2) & 0 \end{bmatrix} \begin{bmatrix} w_1^{[2]} \\ w_2^{[2]} \\ w_3^{[2]} \\ w_4^{[2]} \end{bmatrix} + \begin{bmatrix} h_{11}^{[3, 1]}(1) & 0 & 0 & 0 \\ 0 & h_{11}^{[3, 1]}(2) & 0 & 0 \\ 0 & 0 & h_{11}^{[3, 1]}(3) & h_{12}^{[3, 1]}(3) \\ 0 & 0 & 0 & 0 \\ 0 & 0 & 0 & 0 \\ 0 & 0 & 0 & 0 \\ 0 & 0 & \Gamma_3^{[1]} h_{11}^{[3, 1]}(3) & \Gamma_3^{[1]} h_{12}^{[3, 1]}(3) \end{bmatrix} \begin{bmatrix} w_1^{[3]} \\ w_2^{[3]} \\ w_3^{[3]} \\ w_4^{[3]} \end{bmatrix} \\ + & \begin{bmatrix} 0 & 0 & 0 & 0 \\ 0 & 0 & 0 & 0 \\ 0 & 0 & 0 & 0 \\ h_{C1}^{[1, 2]}(4) & h_{C2}^{[1, 2]}(4) & 0 & 0 \\ 0 & 0 & h_{C1}^{[1, 2]}(5) & 0 \\ 0 & 0 & 0 & h_{C1}^{[1, 2]}(6) \\ \Gamma_4^{[2]} h_{C1}^{[1, 2]}(4) & \Gamma_4^{[2]} h_{C2}^{[1, 2]}(4) & 0 & 0 \end{bmatrix} \begin{bmatrix} x_1^{[1]} \\ x_2^{[1]} \\ x_3^{[1]} \\ x_4^{[1]} \end{bmatrix} + \begin{bmatrix} 0 & 0 & 0 & 0 \\ 0 & 0 & 0 & 0 \\ 0 & 0 & 0 & 0 \\ h_{C1}^{[2, 2]}(4) & 0 & 0 & 0 \\ 0 & h_{C1}^{[2, 2]}(5) & h_{C2}^{[2, 2]}(5) & 0 \\ 0 & 0 & 0 & h_{C1}^{[2, 2]}(6) \\ 0 & \Gamma_5^{[2]} h_{C1}^{[2, 2]}(5) & \Gamma_5^{[2]} h_{C2}^{[2, 2]}(5) & 0 \end{bmatrix} \begin{bmatrix} x_1^{[2]} \\ x_2^{[2]} \\ x_3^{[2]} \\ x_4^{[2]} \end{bmatrix} \\ + & \begin{bmatrix} 0 & 0 & 0 & 0 \\ 0 & 0 & 0 & 0 \\ 0 & 0 & 0 & 0 \\ h_{C1}^{[3, 2]}(4) & 0 & 0 & 0 \\ 0 & h_{C1}^{[3, 2]}(5) & 0 & 0 \\ 0 & 0 & h_{C1}^{[3, 2]}(6) & h_{C2}^{[3, 2]}(6) \\ 0 & 0 & \Gamma_6^{[2]} h_{C1}^{[3, 2]}(6) & \Gamma_6^{[2]} h_{C2}^{[3, 2]}(6) \end{bmatrix} \begin{bmatrix} x_1^{[3]} \\ x_2^{[3]} \\ x_3^{[3]} \\ x_4^{[3]} \end{bmatrix} + \begin{bmatrix} n^{[1]}(1) \\ n^{[1]}(2) \\ n^{[1]}(3) \\ n^{[C]}(4) \\ n^{[C]}(5) \\ n^{[C]}(6) \\ n^{[C]}(7) + n^{[1]}(7) \end{bmatrix} \quad (54) \end{aligned}$$

by the equation below:

$$R_x^{[1]}(t) = \sum_{b=1}^L H_1^{[b,1]}(t) \times T_x^{[b,1]}(t) + n^{[1]}(t), \quad (58)$$

Also, the same information symbols from the cooperative CE users in cell-1 are overheard by the BS-C. Thus, the received signals at the BS-C are denoted by the following equations:

$$R_x^{[C1]}(t) = \sum_{b=1}^L H_C^{[b,1]}(t) \times T_x^{[b,1]}(t) + n^{[C1]}(t). \quad (59)$$

**Stage-2:** This stage is also characterized by  $L$  time slots and is intended for the cooperative CE users belonging to cell-2.

$$T_x^{[b,2]}(t) = \begin{cases} \begin{bmatrix} x_{t'}^{[b]} \\ 0 \end{bmatrix} & \text{for } (t' < b), \\ \begin{bmatrix} x_{t'}^{[b]} \\ x_{t'+1}^{[b]} \end{bmatrix} & \text{for } (t' = b), \\ \begin{bmatrix} x_{t'+1}^{[b]} \\ 0 \end{bmatrix} & \text{for } (t' > b), \end{cases} \quad (60)$$

Here  $(L+1) \leq t \leq 2L$ ,  $t' = (t-L)$  and  $x_k^{[b]}$  denotes the  $k^{\text{th}}$  information symbol for the  $b^{\text{th}}$  user in the BS-2. The signal received by the receiver (BS-2) in this stage for the  $t^{\text{th}}$  time slot is given by the equation below:

$$R_x^{[2]}(t) = \sum_{b=1}^L H_2^{[b,2]}(t) \times T_x^{[b,2]}(t) + n^{[2]}(t), \quad (61)$$

Also, the BS-C overheard the same information symbols from the cooperative CE users in cell-2. Thus, the received signals at the BS-C are denoted by the following equations:

$$R_x^{[C1]}(t) = \sum_{b=1}^L H_C^{[b,2]}(t) \times T_x^{[b,2]}(t) + n^{[C1]}(t). \quad (62)$$

The critical point to be noted at the conclusion of stage-1 is that the BS-1 is characterized by  $L^2$  linearly independent equations with  $L(L+1)$  desired symbols; thus, an additional  $L$  more linear independent equations are needed to resolve the desired symbols. These additional  $L$  linear independent equations are obtained from the BS-C. As BS-C possesses a total of  $2L^2$  overheard equations, none of which pertains to BS-C, but rather to BS-1, ( $L^2$  overheard equation can

$$\begin{bmatrix} R_x^{[1]}(1) \\ R_x^{[1]}(2) \\ R_x^{[1]}(3) \\ [R_x^{[C, 2]}(7) + R_x^{[1]}(7)] - \Gamma_4^{[2]} R_x^{[C]}(4) - \Gamma_5^{[2]} R_x^{[C]}(5) - \Gamma_6^{[2]} R_x^{[C]}(6) \end{bmatrix} = \begin{bmatrix} h_{11}^{[1,1]}(1) & h_{12}^{[1,1]}(1) & 0 & 0 \\ 0 & 0 & h_{11}^{[1,1]}(2) & 0 \\ 0 & 0 & 0 & h_{11}^{[1,1]}(3) \\ \Gamma_1^{[1]} h_{11}^{[1,1]}(1) & \Gamma_1^{[1]} h_{12}^{[1,1]}(1) & 0 & 0 \end{bmatrix} \begin{bmatrix} w_1^{[1]} \\ w_2^{[1]} \\ w_3^{[1]} \\ w_4^{[1]} \end{bmatrix} + \begin{bmatrix} h_{11}^{[2,1]}(1) & 0 & 0 & 0 \\ 0 & h_{11}^{[2,1]}(2) & h_{12}^{[2,1]}(2) & 0 \\ 0 & 0 & 0 & h_{11}^{[3,1]}(3) \\ 0 & \Gamma_2^{[1]} h_{11}^{[2,1]}(2) & \Gamma_2^{[1]} h_{12}^{[1,1]}(2) & 0 \end{bmatrix} \begin{bmatrix} w_1^{[2]} \\ w_2^{[2]} \\ w_3^{[2]} \\ w_4^{[2]} \end{bmatrix} + \begin{bmatrix} h_{11}^{[3,1]}(1) & 0 & 0 & 0 \\ 0 & h_{11}^{[3,1]}(2) & 0 & 0 \\ 0 & 0 & h_{11}^{[3,1]}(3) & h_{12}^{[3,1]}(3) \\ 0 & 0 & \Gamma_3^{[1]} h_{11}^{[3,1]}(3) & \Gamma_3^{[1]} h_{12}^{[3,1]}(3) \end{bmatrix} \begin{bmatrix} w_1^{[3]} \\ w_2^{[3]} \\ w_3^{[3]} \\ w_4^{[3]} \end{bmatrix} + \begin{bmatrix} n^{[1]}(1) \\ n^{[1]}(2) \\ n^{[1]}(3) \\ [n^{[C]}(7) + n^{[1]}(7)] - \Gamma_4^{[2]} n^{[C]}(4) - \Gamma_5^{[2]} n^{[C]}(5) - \Gamma_6^{[2]} n^{[C]}(6) \end{bmatrix} \quad (55)$$

$$\begin{bmatrix} R_x^{[2]}(4) \\ R_x^{[2]}(5) \\ R_x^{[2]}(6) \\ [R_x^{[C, 1]}(7) + R_x^{[2]}(7)] - \Gamma_1^{[1]} R_x^{[C]}(1) - \Gamma_2^{[1]} R_x^{[C]}(2) - \Gamma_3^{[1]} R_x^{[C]}(3) \end{bmatrix} = \begin{bmatrix} h_{21}^{[1,2]}(4) & h_{22}^{[1,2]}(4) & 0 & 0 \\ 0 & 0 & h_{21}^{[1,2]}(5) & 0 \\ 0 & 0 & 0 & h_{21}^{[1,2]}(6) \\ \Gamma_4^{[2]} h_{21}^{[1,2]}(4) & \Gamma_4^{[2]} h_{22}^{[1,2]}(4) & 0 & 0 \end{bmatrix} \begin{bmatrix} x_1^{[2]} \\ x_2^{[2]} \\ x_3^{[2]} \\ x_4^{[2]} \end{bmatrix} + \begin{bmatrix} h_{21}^{[2,2]}(4) & 0 & 0 & 0 \\ 0 & h_{21}^{[2,2]}(5) & h_{22}^{[2,2]}(5) & 0 \\ 0 & 0 & 0 & h_{21}^{[2,2]}(6) \\ 0 & \Gamma_5^{[2]} h_{21}^{[2,2]}(5) & \Gamma_5^{[2]} h_{22}^{[2,2]}(5) & 0 \end{bmatrix} \begin{bmatrix} x_1^{[1]} \\ x_2^{[1]} \\ x_3^{[1]} \\ x_4^{[1]} \end{bmatrix} + \begin{bmatrix} h_{21}^{[3,2]}(4) & 0 & 0 & 0 \\ 0 & h_{21}^{[3,2]}(5) & 0 & 0 \\ 0 & 0 & h_{21}^{[3,2]}(6) & h_{22}^{[3,2]}(6) \\ 0 & 0 & \Gamma_6^{[2]} h_{21}^{[3,2]}(6) & \Gamma_6^{[2]} h_{22}^{[3,2]}(6) \end{bmatrix} \begin{bmatrix} x_1^{[3]} \\ x_2^{[3]} \\ x_3^{[3]} \\ x_4^{[3]} \end{bmatrix} + \begin{bmatrix} n^{[2]}(4) \\ n^{[2]}(5) \\ n^{[2]}(6) \\ [n^{[C]}(7) + n^{[2]}(7)] - \Gamma_1^{[1]} n^{[C]}(1) - \Gamma_2^{[1]} n^{[C]}(2) - \Gamma_3^{[1]} n^{[C]}(3) \end{bmatrix} \quad (56)$$

**Algorithm 1** Interference Alignment for Cooperative CE Users

---

```

1: Initialize  $L, t, \text{Tx}^{[b,1]}(t), \text{Tx}^{[b,2]}(t), a, b.$ 
2: To Compute DoF of cooperative CE users in a multi-cellular MIMO IMAC with the aid of a common BS (BS-C).
3: for determining the user location  $L > \frac{\|h_{\frac{L}{2}}\| + \|h_{\frac{L}{2}+1}\|}{2}$  do
4:   The CC, CM and CE users are obtained, then the tri-staged algorithm is proposed.
5:   for  $L$  in cell-1 do
6:     for  $t = 1$  to  $L$  do
7:       Compute the received signals at BS-1 denoted by  $\text{Rx}^{[1]}(t)$  using equation (58),
8:       Compute the overheard signals at BS-C denoted by  $\text{Rx}^{[C]}(t)$  using equation (59),
9:       Perform interference refining for the obtained  $\text{Rx}^{[C]}(t)$  using equation (63) and store the resultant value as
           $\hat{\text{S}}_t^{[C]}(w_t^{[r]}, w_{t+1}^{[r]}).$ 
10:      end for
11:    end for ★ → Stage-1
12:    for  $L$  in cell-2 do
13:      for  $t = (L+1)$  to  $2L$  do
14:        Compute the received signals at BS-1 denoted by  $\text{Rx}^{[2]}(t)$  using equation (61),
15:        Compute the overheard signals at BS-C denoted by  $\text{Rx}^{[C]}(t)$  using equation (62),
16:        Perform interference refining for the obtained  $\text{Rx}^{[C]}(t)$  using equation (65) and store the resultant value as
           $\hat{\text{S}}_t^{[C]}(x_{t'}^{[r]}, x_{t'+1}^{[r]}).$ 
17:      end for
18:    end for ★ → Stage-2
19:    for  $t = 2L+1$  do
20:      Equation denoting  $\text{Tx}^{[b,1]}(2L+1)$  and  $\text{Tx}^{[b,2]}(2L+1)$  are formed by using the interference refined equation obtained
          in (67),
21:      Compute the signals received at the BS-C from the cooperative CE users in cell-1 denoted by  $\text{Rx}^{[C,1]}(2L+1)$  using
          equation (68),
22:      Compute the signals received at the BS-C from the cooperative CE users in cell-2 denoted by  $\text{Rx}^{[C,2]}(2L+1)$  using
          equation (69),
23:      Compute  $\text{Rx}^{[1]}(2L+1)$  using equation (70),
24:      Compute  $\text{Rx}^{[2]}(2L+1)$  using equation (71),
25:      Compute the total received signal from the cooperative CE users in cell-1 by adding steps 22 and 23,
26:      Compute the total received signal from the cooperative CE users in cell-2 by adding steps 21 and 24,
27:      Develop the equations for inter-cell interference-free desired signals using equations in (74) and (75).
28:    end for ★ → Stage-3
29:    Interference refining and interference redirecting are performed with the aid of BS-C.
30:    Compute the DoF ( $d_1$ ) and DoF ( $d_2$ ) for cell-1 and cell-2, respectively,
31:    Total DoF ( $D$ ) = DoF ( $d_1$ ) + DoF ( $d_2$ ).
32:  end for

```

---

be utilized by BS-1) and BS-2 ( $L^2$  overheard equations can be utilized by BS-2). Similarly, the BS-2 is also deficit by  $L$  linear independent equations. This insufficiency of the  $L$  linear independent equations is handled by the BS-C that received extra overheard equations during stage-2. Subsequently, the outdated CSIT based RIA scheme is utilized at the initial stage where the overheard equations need to be refined by using appropriate linear combinations, resulting in  $L$  new linear equations per cell that are purely in terms of one transmitters information symbol. Thus, the equations overheard by the BS-C during stage-1 are modified and is used in BS-2. Therefore, the refined overheard equation for  $1 \leq t \leq L$  is as shown below:

$$\hat{\text{S}}_t^{[C]}(w_t^{[r]}, w_{t+1}^{[r]}) = \text{W}_t^{[1]\dagger} \text{S}_t^{[C]}(w_{t+1}^{[1]}, w_{t+1}^{[2]}, \dots, w_t^{[L]}), \quad (63)$$

Here,  $\text{W}_t^{[1]\dagger}$  denotes the conjugate transpose of combining vector for the equations overheard at time slot  $1 \leq t \leq L$  during the stage-1.  $\hat{\text{S}}_t^{[C]}(w_t^{[r]}, w_{t+1}^{[r]})$  denotes the newly formed linear equation that purely consists of symbols sent by a transmitter. The interference refining method treats the linear equations by considering locally created delayed CSIT at that transmitter. Furthermore, it is necessary for the combining vector  $\text{W}_t^{[1]}$  to meet the following criteria:

$$\begin{aligned} \text{W}_t^{[1]\dagger} \times \text{H}_C^{[\bar{r},1]}(t) \times \text{Tx}^{[\bar{r},1]}(t) &= 0, \\ \forall t, \bar{t} \in \{1, 2, \dots, L\}, \bar{t} &\neq t. \end{aligned} \quad (64)$$

Similarly, the equations overheard by the BS-C during stage-2 are modified and is used in BS-1. Therefore, the refined

overheard equations illustrating the same for  $(L+1) \leq t \leq 2L$  are as shown below:

$$\hat{S}_t^{[C]}(x_{t'}^{[r]}, x_{t'+1}^{[r]}) = W_t^{[2]\dagger} S_t^{[C]}(x_{t'+1}^{[1]}, x_{t'+1}^{[2]}, \dots, x_{t'}^{[L]}), \quad (65)$$

Here,  $W_t^{[2]\dagger}$  denotes the conjugate transpose of combining vector for the equations overheard at time slot  $(L+1) \leq t \leq 2L$  during the stage-2. Also, it is necessary for the combining vector  $W_t^{[2]}$  to meet the following criteria:

$$W_t^{[2]\dagger} \times H_C^{[r',2]}(t') \times T_x^{[r',2]}(t') = 0, \quad \forall t', t' \in \{(L+1), \dots, 2L\}, t' \neq t'. \quad (66)$$

Thus, it can be concluded that without the interference refining process, the individual transmitters are unable to provide the locally created delayed CSIT linear equations. The purpose of stage-3 is to redirect the refined overheard equations from the BS-C to the intended BS's (i.e., BS-1 and BS-2). Therefore, in stage-3, each transmitter reconstructs the subsequently transmitted signals using the delayed CSIT and previously sent symbols.

**Stage-3:** This stage functions in a single time slot  $(2L+1)$  and the information symbols transmitted in this stage are as follows:

$$T_x^{[b,1]}(2L+1) = \begin{bmatrix} \hat{S}_b^{[C]}(w_b^{[b]}, w_{b+1}^{[b]}) \\ 0 \end{bmatrix}, \quad T_x^{[b,2]}(2L+1) = \begin{bmatrix} \hat{S}_{b'}^{[C]}(x_b^{[b]}, x_{b+1}^{[b]}) \\ 0 \end{bmatrix}, \quad \forall b' = (b+L). \quad (67)$$

The signals received at the BS-C from the transmitters (cooperative CE users) present in the cell-1 and cell-2 respectively are depicted as below:

$$R_x^{[C,1]}(2L+1) = \sum_{b=1}^L h_{C1}^{[b,1]}(2L+1) \times \hat{S}_b^{[c]}(w_b^{[b]}, w_{b+1}^{[b]}) + n^{[C]}(2L+1), \quad (68)$$

$$R_x^{[C,2]}(2L+1) = \sum_{b=1}^L h_{C1}^{[b,2]}(2L+1) \times \hat{S}_{b'}^{[c]}(x_b^{[b]}, x_{b+1}^{[b]}) + n^{[C]}(2L+1). \quad (69)$$

The signals received by the BS-1, BS-2 from the transmitters present in the cell-1 and cell-2 are depicted below:

$$R_x^{[1]}(2L+1) = \sum_{b=1}^L h_{11}^{[b,1]}(2L+1) \times \hat{S}_b^{[c]}(w_b^{[b]}, w_{b+1}^{[b]}) + n^{[1]}(2L+1), \quad (70)$$

$$R_x^{[2]}(2L+1) = \sum_{b=1}^L h_{21}^{[b,2]}(2L+1) \times \hat{S}_{b'}^{[c]}(x_b^{[b]}, x_{b+1}^{[b]}) + n^{[2]}(2L+1). \quad (71)$$

Therefore, the total received signal by summing up the intended redirected signal from the BS-C and the BSs of the individual cells i.e., cell-1 and cell-2 are as follows:

$$R_x^{[C,2]}(2L+1) + R_x^{[1]}(2L+1) = \sum_{b=1}^L h_{C1}^{[b,2]}(2L+1) \times \hat{S}_{b'}^{[c]}(x_b^{[b]}, x_{b+1}^{[b]}) + \sum_{b=1}^L h_{11}^{[b,1]}(2L+1) \times \hat{S}_b^{[c]}(w_b^{[b]}, w_{b+1}^{[b]}) + n^{[C]}(2L+1) + n^{[1]}(2L+1), \quad (72)$$

$$R_x^{[C,1]}(2L+1) + R_x^{[2]}(2L+1) = \sum_{b=1}^L h_{C1}^{[b,1]}(2L+1) \times \hat{S}_b^{[c]}(w_b^{[b]}, w_{b+1}^{[b]}) + \sum_{b=1}^L h_{21}^{[b,2]}(2L+1) \times \hat{S}_{b'}^{[c]}(x_b^{[b]}, x_{b+1}^{[b]}) + n^{[C]}(2L+1) + n^{[2]}(2L+1). \quad (73)$$

The ICI that exists between the cooperative CE users can be eliminated by considering the following equations:

$$[R_x^{[C,2]}(2L+1) + R_x^{[1]}(2L+1)] - \sum_{b=1}^L h_{C1}^{[b,2]}(2L+1) \times \hat{S}_{b'}^{[c]}(x_b^{[b]}, x_{b+1}^{[b]}) = \left[ h_{11}^{[1,1]}(2L+1) \dots h_{11}^{[L,1]}(2L+1) \right] \times \begin{bmatrix} \hat{S}_1^{[2]}(w_1^{[1]}, w_2^{[1]}) \\ \vdots \\ \hat{S}_L^{[2]}(w_L^{[L]}, w_{L+1}^{[L]}) \end{bmatrix} + n^{[1]}(2L+1), \quad (74)$$

$$R_x^{[C,1]}(2L+1) + R_x^{[2]}(2L+1) - \sum_{b=1}^L h_{C1}^{[b,1]}(2L+1) \times \hat{S}_b^{[c]}(w_b^{[b]}, w_{b+1}^{[b]}) = \left[ h_{21}^{[1,1]}(2L+1) \dots h_{21}^{[L,1]}(2L+1) \right] \times \begin{bmatrix} \hat{S}_1^{[2]}(x_1^{[1]}, x_2^{[1]}) \\ \vdots \\ \hat{S}_L^{[2]}(x_L^{[L]}, x_{L+1}^{[L]}) \end{bmatrix} + n^{[2]}(2L+1). \quad (75)$$

Therefore, each BS (BS-1 and BS-2) individually decodes a total of  $L(L+1)$  data symbols towards the conclusion of stage-3. Thus, by successfully performing the interference refining and interference redirecting processes, a total of  $\frac{2L(L+1)}{2L+1}$  DoF are attained.

## V. NUMERICAL RESULTS

In this section, numerical results are presented to illustrate the improved performance of the cooperative CE users through a novel tri-staged outdated CSIT-based RIA scheme. Furthermore, the achievable DoF reported by the schemes [8], [16] and [38] are considered to be the benchmark schemes for comparison. Figure 5 compares the DoF achieved by the proposed tri-staged outdated CSIT-based RIA scheme and other benchmark schemes to the number of users. It is



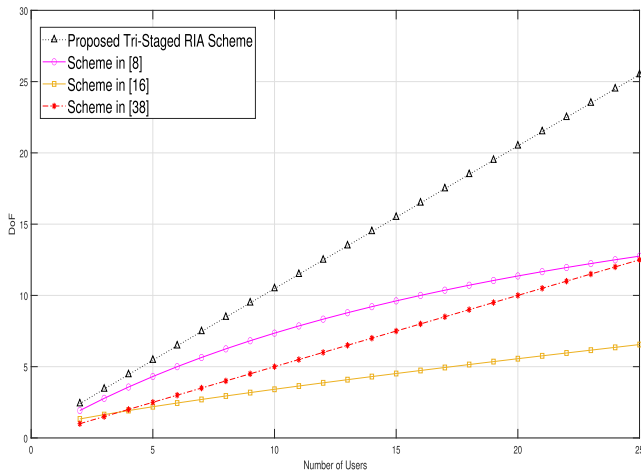

**FIGURE 5.** Comparison of DoF by the proposed tri-staged RIA scheme with other benchmark schemes.

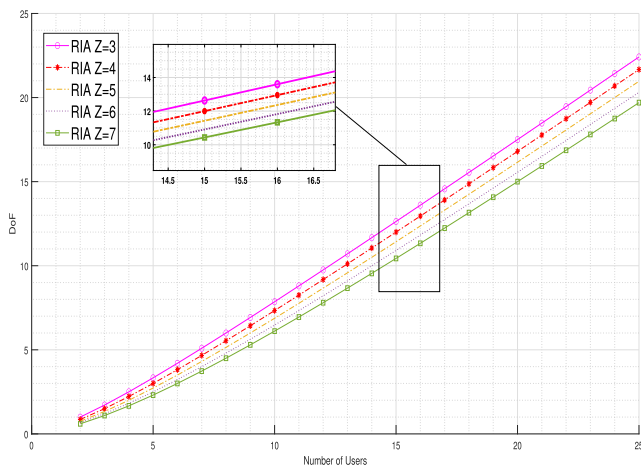

**FIGURE 6.** Achievable DoF against the number of users for the proposed tri-staged RIA scheme.

observed that the proposed scheme's achieved DoF scales with the number of users. As a result, this scheme achieves a greater DoF than all of the other benchmark IA schemes such as BIA [8], IA with completely delayed CSIT [16] and IA with perfect CSIT [38]. The DoF of a general cooperative  $L$ -CE user in a multi-cellular MIMO IMAC is obtained to be  $\frac{2L(L+1)}{2L+1}$ . Therefore the DoF starts from  $\frac{12}{5}$  for a two-user case and attains  $\frac{1300}{51}$  as the value of  $L$  reaches 25.

Each BS decodes  $L(L+1)$  data symbols individually in  $2L+1$  time slots, resulting in a DoF of  $\frac{L(L+1)}{2L+1}$ . This obtained DoF equation of the individual BS is modified by substituting  $Z+L$  for  $2L$ , resulting in a new equation denoted by  $\frac{L(L+1)}{Z+L+1}$ . Figure 6 depicts the achievable DoF versus the number of users for the proposed tri-staged RIA scheme with varying  $Z$  values.

## VI. CONCLUSION

This paper presents user classification, a tri-staged outdated CSIT-based RIA scheme and the common BS concepts. The proposed work also classifies the users into three groups: CC, CM and CE users. Among these, cooperative CE users are more vulnerable to ICI in MIMO IMAC networks. Thus, the

proposed method enhances the efficiency of the cooperative CE users by implementing a novel tri-staged outdated CSIT-based RIA scheme. This proposed RIA scheme is characterized by interference refining at the end of the first two stages and interference redirecting at the third stage to enhance the CE user's performance. Where the BS-C overhears the edge user's signal from the BS-1 and BS-2 to determine the desired DoF. Therefore, the DoF of the cooperative three CE users is obtained to be  $\frac{24}{7}$ , where  $\frac{12}{7}$  is from BS-1 and the remaining  $\frac{12}{7}$  is from BS-2. Further, a general cooperative  $L$ -CE user in a multi-cellular MIMO IMAC is calculated to have a DoF of  $\frac{2L(L+1)}{2L+1}$ . Additionally, the simulation results demonstrate that the proposed scheme increases cooperative CE user performance. For future work, we will extend the consideration of inter-symbol interference and inter-user interference between CC, CM, and CE users to assess individual user performance to determine the desired DoF.

## REFERENCES

- [1] L. Suo, H. Li, S. Zhang, and J. Li, "Successive interference cancellation and alignment in  $K$ -user MIMO interference channels with partial unidirectional strong interference," *China Commun.*, vol. 19, no. 2, pp. 118–130, Feb. 2022.
- [2] W. Liu, K. Liu, L. Tian, C. Zhang, and Y. Yang, "Joint interference alignment and subchannel allocation in ultra-dense networks," *IEEE Trans. Veh. Technol.*, vol. 71, no. 7, pp. 7287–7296, Jul. 2022.
- [3] M. A. Maddah-Ali and D. Tse, "On the degrees of freedom of MISO broadcast channels with delayed feedback," Dept. EECS, Univ. California, Berkeley, CA, USA, Tech. Rep. UCB/EECS-2010-122, Sep. 2010.
- [4] J. Li, Z. Xiong, W. Feng, W. Jiang, and D. Niyato, "Retrospective interference regeneration schemes for relay-aided  $K$ -user MIMO broadcast networks," in *Proc. IEEE Int. Conf. Commun.*, May 2022, pp. 5153–5158.
- [5] N. Lee and R. W. Heath, Jr., "Space-time interference alignment and degree-of-freedom regions for the MISO broadcast channel with periodic CSI feedback," *IEEE Trans. Inf. Theory*, vol. 60, no. 1, pp. 515–528, Jan. 2014.
- [6] Z. Li and H. Sun, "Conditional disclosure of secrets: A noise and signal alignment approach," *IEEE Trans. Commun.*, vol. 70, no. 6, pp. 4052–4062, Jun. 2022.
- [7] T. Gou, C. Wang, and S. A. Jafar, "Aiming perfectly in the dark-blind interference alignment through staggered antenna switching," *IEEE Trans. Signal Process.*, vol. 59, no. 6, pp. 2734–2744, Jun. 2011.
- [8] V. Menon and P. Selvaprabhu, "Blind interference alignment: A comprehensive survey," *Int. J. Commun. Syst.*, vol. 35, no. 8, Feb. 2022, p. e5116.
- [9] H. Maleki, S. A. Jafar, and S. Shamai, "Retrospective interference alignment," in *Proc. IEEE Int. Symp. Inf. Theory*, Jul. 2011, pp. 2756–2760.
- [10] H. Maleki, S. A. Jafar, and S. Shamai, "Retrospective interference alignment over interference networks," *IEEE J. Sel. Topics Signal Process.*, vol. 6, no. 3, pp. 228–240, Jun. 2012.
- [11] M. Seif, R. Tandon, and M. Li, "Secure retrospective interference alignment," *Entropy*, vol. 21, no. 11, p. 1092, Oct. 2019.
- [12] W. Liu and C. Zhang, "Cache-aided retrospective interference alignment in SISO X wireless networks," *IEEE Access*, vol. 8, pp. 133225–133232, 2020.
- [13] J. Li, W. Feng, F. R. Yu, and W. Jiang, "Two new kinds of interference alignment schemes for cellular  $K$ -user MIMO downlink networks," *IEEE Trans. Veh. Technol.*, vol. 70, no. 11, pp. 11827–11842, Nov. 2021.
- [14] J. Li, Z. Xiong, D. Niyato, W. Su, W. Feng, and W. Jiang, "Retrospective interference regeneration schemes for relay-aided  $K$ -user MIMO downlink networks," 2021, *arXiv:2106.12805*.
- [15] W. Liu and G. Wu, "Cache-aided retrospective interference alignment in wireless broadcast channels," *IEEE Trans. Veh. Technol.*, vol. 71, no. 2, pp. 1509–1518, Feb. 2022.
- [16] M. A. Maddah-Ali and D. Tse, "Completely stale transmitter channel state information is still very useful," *IEEE Trans. Inf. Theory*, vol. 58, no. 7, pp. 4418–4431, Jul. 2012.

- [17] C. S. Vaze and M. K. Varanasi, "The degrees of freedom region and interference alignment for the MIMO interference channel with delayed CSIT," *IEEE Trans. Inf. Theory*, vol. 58, no. 7, pp. 4396–4417, Jul. 2012.
- [18] M. J. Abdoli, A. Ghasemi, and A. K. Khandani, "On the degrees of freedom of K-user SISO interference and X channels with delayed CSIT," *IEEE Trans. Inf. Theory*, vol. 59, no. 10, pp. 6542–6561, Oct. 2013.
- [19] R. Tandon, S. Mohajer, H. V. Poor, and S. Shamai, "Degrees of freedom region of the MIMO interference channel with output feedback and delayed CSIT," *IEEE Trans. Inf. Theory*, vol. 59, no. 3, pp. 1444–1457, Mar. 2013.
- [20] M. Torrellas, A. Agustin, and J. Vidal, "Retrospective interference alignment for the 3-user MIMO interference channel with delayed CSIT," in *Proc. IEEE Int. Conf. Acoust., Speech Signal Process. (ICASSP)*, May 2014, pp. 2445–2449.
- [21] D. Castanheira, A. Silva, and A. Gameiro, "Retrospective interference alignment for the K-user  $M \times N$  MIMO interference channel," *IEEE Trans. Wireless Commun.*, vol. 15, no. 12, pp. 8368–8379, Dec. 2016.
- [22] D. Castanheira, A. Silva, and A. Gameiro, "Retrospective interference alignment: Degrees of freedom scaling with distributed transmitters," *IEEE Trans. Inf. Theory*, vol. 63, no. 3, pp. 1721–1730, Mar. 2017.
- [23] A. Ghasemi, A. S. Motahari, and A. K. Khandani, "On the degrees of freedom of X channel with delayed CSIT," in *Proc. IEEE Int. Symp. Inf. Theory*, Jul. 2011, pp. 767–770.
- [24] S. Lashgari, A. S. Avestimehr, and C. Suh, "Linear degrees of freedom of the X-channel with delayed CSIT," *IEEE Trans. Inf. Theory*, vol. 60, no. 4, pp. 2180–2189, Apr. 2014.
- [25] T. Ying, W. Feng, W. Su, and W. Jiang, "On the degrees of freedom of MIMO X networks with non-cooperation transmitters," *IEEE Trans. Wireless Commun.*, vol. 16, no. 4, pp. 2490–2504, Apr. 2017.
- [26] D. T. H. Kao and A. S. Avestimehr, "Linear degrees of freedom of the MIMO X-channel with delayed CSIT," *IEEE Trans. Inf. Theory*, vol. 63, no. 1, pp. 297–319, Jan. 2017.
- [27] R. Tandon, S. Mohajer, H. V. Poor, and S. Shamai, "On X-channels with feedback and delayed CSI," in *Proc. IEEE Int. Symp. Inf. Theory*, Jul. 2012, pp. 1877–1881.
- [28] C. S. Vaze and M. K. Varanasi, "The degrees of freedom region of the two-user MIMO broadcast channel with delayed CSIT," in *Proc. IEEE Int. Symp. Inf. Theory*, Jul. 2011, pp. 199–203.
- [29] M. Torrellas, A. Agustin, and J. Vidal, "Retrospective interference alignment for the MIMO interference broadcast channel," in *Proc. IEEE Int. Symp. Inf. Theory (ISIT)*, Oct. 2015, pp. 1492–1496.
- [30] B. Zhuang, R. A. Berry, and M. L. Honig, "Interference alignment in MIMO cellular networks," in *Proc. IEEE Int. Conf. Acoust., Speech Signal Process. (ICASSP)*, May 2011, pp. 3356–3359.
- [31] H. J. Yang, W.-Y. Shin, B. C. Jung, and A. Paulraj, "Opportunistic interference alignment for MIMO interfering multiple-access channels," *IEEE Trans. Wireless Commun.*, vol. 12, no. 5, pp. 2180–2192, May 2013.
- [32] X. Qu and C. G. Kang, "A closed-form solution to implement interference alignment and cancellation for a Gaussian interference multiple access channel," *IEEE Trans. Wireless Commun.*, vol. 13, no. 2, pp. 710–723, Feb. 2014.
- [33] W. Shin and J. Lee, "Retrospective interference alignment for the two-cell MIMO interfering multiple access channel," *IEEE Trans. Wireless Commun.*, vol. 14, no. 7, pp. 3937–3947, Jul. 2015.
- [34] P. Selvaprabhu, S. Chinnadurai, I. Tamilarasan, R. Venkatesan, and V. B. Kumaravelu, "Priority-based resource allocation and energy harvesting for WBAN smart health," *Wireless Commun. Mobile Comput.*, vol. 2022, pp. 1–11, Jul. 2022.
- [35] X. Chen, Z. Zhang, L. Zheng, L. Wu, J. Dang, P.-S. Lu, and C. Sun, "Blind interference alignment in two-cell Z interference MIMO channel," *IEEE Access*, vol. 5, pp. 10526–10532, 2017.
- [36] P. Selvaprabhu, S. Chinnadurai, M. A. L. Sarker, and M. H. Lee, "Joint interference alignment and power allocation for K-user multicell MIMO channel through staggered antenna switching," *Sensors*, vol. 18, no. 2, p. 380, Jan. 2018.
- [37] S. Chinnadurai, P. Selvaprabhu, Y. Jeong, A. L. Sarker, H. Hai, W. Duan, and M. H. Lee, "User clustering and robust beamforming design in multicell MIMO-NOMA system for 5G communications," *AEU-Int. J. Electron. Commun.*, vol. 78, pp. 181–191, Aug. 2017.
- [38] V. R. Cadambe and S. A. Jafar, "Interference alignment and degrees of freedom of the K-user interference channel," *IEEE Trans. Inf. Theory*, vol. 54, no. 8, pp. 3425–3441, Aug. 2008.



**VIVEK MENON U** received the master's degree in communication engineering from the Vellore Institute of Technology, Vellore, Tamil Nadu, India, in 2019, where he is currently pursuing the Ph.D. degree with the Department of Electronics and Communication Engineering. He has participated in various conferences, such as the International Conference on Vision Towards Emerging Trends in Communication and Networking (ViTECoN-2019) and the International Conference on Micro-electronic Devices, Circuits and Systems (ICMDCS), organized by the Vellore Institute of Technology. His main research interests include interference alignment in wireless communication systems, blind interference alignment, massive MIMO, and the Internet of Things.



**POONGUNDRAN SELVAPRABHU** received the bachelor's degree in electronics and communication engineering from Anna University, India, in 2009, the master's degree in electronics design from Mid Sweden University, Sweden, in 2012, and the Ph.D. degree in wireless and mobile communications from Chonbuk National University, Republic of Korea, in 2017. He worked as a Postdoctoral Research Fellow at the Division of Electronics and Information Engineering, Chonbuk National University and Inha University, Republic of Korea, from 2017 to 2018. He is currently working as an Assistant Professor (Senior Grade II) with the Vellore Institute of Technology, Vellore, Tamil Nadu, India. He was a participant of many projects, such as Brain Korea-21 (BK-21), World Class University (WCU), and the Ministry of Education Science and Technology (MEST) Project, which funded by NRF, Republic of Korea. His main research interests include 5G wireless communications, especially interference alignment for massive MIMO, signal processing, information theory, NOMA, and wireless body area networks (WBAN) with a focus on energy optimization and algorithm design.

...