

## RESEARCH ARTICLE

# Simulation Analysis of Grounding Characteristics of Cable Based on ATP-EMTP

YOUCONG HUANG<sup>1</sup>, ZHIWEI FU<sup>2</sup>, ZHONGNAN ZHENG<sup>1</sup>, TUO SHI<sup>3</sup>,  
YING ZHANG<sup>1</sup>, SHAKANG CHEN<sup>2</sup>, AND JING JIAO<sup>3</sup>

<sup>1</sup>State Grid Fujian Electric Power Research Institute, Fuzhou 350007, China

<sup>2</sup>State Grid Fujian Electric Power Company Ltd., Fuzhou 350000, China

<sup>3</sup>School of Automobile and Rail Transit, Nanjing Institute of Technology, Nanjing 211167, China

Corresponding author: Youcong Huang (hyoucong@163.com)

This work was supported by the Research on Key Technologies of Transmission Capacity Optimization and Health Status Evaluation of UHVAC Submarine cable lines under Grant 5500-202121120A-0-0-00.

**ABSTRACT** In order to improve the operational safety and stability of power cables, it is necessary to conduct targeted research on different grounding modes. Firstly, the appropriate cable parameters were selected according to the specific use, and the model was established in ATP-EMTP according to the selected cable parameters. Then, the availability of three grounding modes models of grounding at one end, grounding at both ends and cross-connection grounding (cable core grounding, shielding layer grounding and armor layer grounding) were compared and verified by simulation. Finally, by setting the shielding layers of different thicknesses as a comparison, the impedance and current characteristics of the cables under three different grounding methods were analyzed. The result indicates that the impedance values of the three grounding methods are essentially the same. However, according to the current characteristics, when the shielding layer and the armored layer are cross-connected and grounded, their current is much smaller than that which is grounded by other grounding methods. Therefore, under the comprehensive consideration of economic benefits, this grounding is the best choice. This study provides guidance for the grounding mode of cable early laying and a reference for other cable related research.

**INDEX TERMS** ATP-EMTP, current, grounding mode, impedance, power cable.

## I. INTRODUCTION

The main function of power cables is to transmit and distribute electrical energy. It is widely used in urban underground power grids. In addition, it is also widely used in power station lead-out lines and underwater transmission lines. With the economic development of coastal cities and islands, cables have become an important way of power transmission between land and sea, and undertake the heavy responsibility of offshore wind farm power transmission channels [1]. In recent years, cross-linked polyethylene (XLPE) insulated power cables have become more popular [2]. Compared with overhead lines, laying power cables into the ground is simpler, saves urban space, and can greatly reduce costs. With the proposal of the marine development strategy, the combined sea-land transmission and distribution

network has been widely used. Especially for the transmission lines of some islands, the hybrid transmission mode of submarine cable - land cable - overhead line is adopted [3]. Therefore, the carrying capacity and durability of the cable are very important.

When building a cable line, the choice of the cable grounding method is very important. The common grounding method is shown in Fig. 1. By comparing the characteristics of grounding methods such as grounding at one end of the metal sheath, grounding at both ends, and cross-connection grounding (grounding of the cable core, shielding layer, and armoring layer), Dongjian Lv [4] pointed out that long-length high-voltage submarine cables are suitable for metal sheathing at both ends. The set position adopted a three-phase interconnected grounding scheme. Xie et al. [5], it concluded that a bridge is suitable for a hybrid grounding method that combines cross-connection grounding and single-point grounding at one end or single-point grounding at the center. It can

The associate editor coordinating the review of this manuscript and approving it for publication was Ahmed Aboushady.

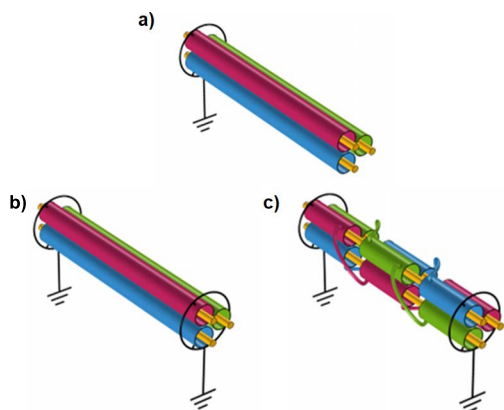

**FIGURE 1.** Common interconnection types of cables. a) One-end grounding. b) Two-end grounding. c) Cross-interconnection grounding.

be seen that laying cables in different application scenarios requires specific analysis.

The main purpose of cable grounding is to ensure safety during cable operation and maintenance. Once the insulation of the metal sheath of the high-voltage cable is damaged, it will inevitably cause multi-point grounding of the metal sheath, which will lead to a significant increase in the sheath circulating current value, thereby accelerating the aging of the cable insulation, shortening the service life and transmission capacity of the cable, and threatening the safe and stable operation of the power system [6], [7], [8]. Therefore, before laying the cable, it is necessary to simulate and calculate the grounding method of the cable to eliminate the above-mentioned safety hazards. References [9] and [10] simulated the single-ended grounding and cross-connected grounding of three-phase cables through the electromagnetic transient simulation software ATP, and obtained the correlation between the circulating current value and the fault distance. In addition, the influence of soil resistivity, grounding resistance and three-phase cable laying method on sheath circulating current was studied, which provided reference for circulating current monitoring and sheath fault diagnosis.

In addition, in order to reduce the circulating current and the voltage at the end of the control cable, cross-connection is generally used for long-distance power transmission. When the cable fails, the fault current of the core wire in the cross-connection operation mode is quite different from that of the direct grounding. Therefore, it is extremely important to accurately identify the faults of different cross-connection segments for the cable fault determination. Wang et al. in [11], ATP simulation modeling was used to study the direction and magnitude of fault current in three-core cables in different cross-connection sections. And the ATP simulation data was summarized to get the fault current direction and magnitude judgment rule of the cable when it was directly grounded and grounded through a transition impedance, which realized the precise location of faults in key parts of the cable and reduced unnecessary power outages caused by cable faults. Liu [12] analyzed the grounding characteristics of

single-core power cables from the perspective of safety. When the cable was grounded at both ends, the metal sheath will form a loop with the ground. Compared with grounding at one end, it will only produce smaller eddy current losses in the metal sheath. Cross-connected grounding can prevent large circulating current losses, and this method was often applied to high-voltage, long-length cables [13]. This paper further explores the impedance and current characteristics of different grounding methods for specific cable models.

## II. PARAMETER DESIGN AND MODELING

### A. PARAMETER DESIGN OF SINGLE-CORE CABLE

Due to the harsh seabed environment and complex geological structure, the design requirements of cables are strict. The designed cable model is shown in Fig. 2, which needs to include water-resisting copper conductor, conductor shielding, XLPE insulation, insulation shielding, buffer water-resisting layer, alloy lead sleeve, semi-conductive PE sheath, armor cushion, armor copper wire and outer cover.

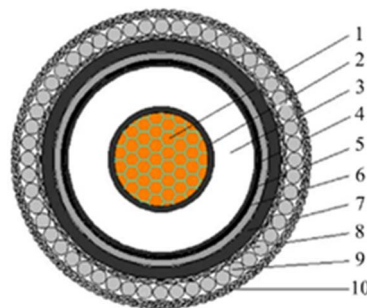

**FIGURE 2.** Chart of cable structure 1-Water-resisting copper conductor; 2-Conductor shielding; 3-XLPE insulation; 4-Insulation shielding; 5-Buffer water-resisting layer; 6-Alloy lead sleeve; 7-Semi-conductive PE sheath; 8-Armor cushion; 9-Armor copper wire; 10-Outer cover.

According to GB/T 18890. 2-2015 standard, conductor with nominal cross-sectional area of more than 800 mm<sup>2</sup> should adopt segmented conductor structure. The insulation material is cross-linked polyethylene (XLPE). The metal lead sleeve can effectively prevent the infiltration of seawater, and has good bending performance and corrosion resistance. In addition, in order to better protect the cable, it is necessary to install metal armor on the outer sheath, which can greatly reduce the wear and impact consumption during the laying of cables. The armor layer is composed of copper wire and asphalt to ensure the requirements of cable transmission current and traction tension. The specific parameters are shown in Table 1.

### B. SINGLE-CORE CABLE MODELING

The single-core cable model is established in the electromagnetic transient simulation software ATP-EMTP. It is necessary to set the power cable form to be single-core cable, the number of phases to be 3, the laying form to be underground, and the calculation model to be the PI model. This study mainly studies the grounding characteristics, so the PI model

TABLE 1. Cable parameters.

Serial number	Structure	Thickness (mm)	Diameter and Tolerance (mm)
1	Water-resisting copper conductor		47.6±0.3
2	Semiconductive tape + extrusion conductor shielding	2×0.27+1.5	51.8±0.5
3	XLPE insulation	24.0	99.8±1.5
4	Insulation shielding	1.2	102.2±1.5
5	Buffer water-resisting layer	2×0.5	104.2±1.5
6	Alloy lead sleeve	4.1	112.4±2.5
7	Semi-conductive PE sheath	3.7	119.8±3.0
8	Armor cushion	2.0	122.8±3.0
9	Armor copper wire + asphalt	(63±3)×Φ6.0	134.8±3.0
10	PP outer cover	4.0	142.8±4.0

is selected. In addition, the parameters of the cable core layer, insulating layer and armor layer are set respectively. Since the cable cores are mostly split conductors, in order to improve the accuracy of the model, the resistivity needs to be corrected. In addition, the semiconductor layer cannot be modeled in the ATP software. In order to facilitate the calculation, the water blocking layer and the sheath in Fig. 1 are combined, and the dielectric constant needs to be corrected [14].

Modeling is performed according to the above steps, and the model is obtained as shown in Fig. 3. Fig. 3(a) shows the modeling structure diagram of the single-core cable. Fig. 3(b) shows the cable laying position diagram.

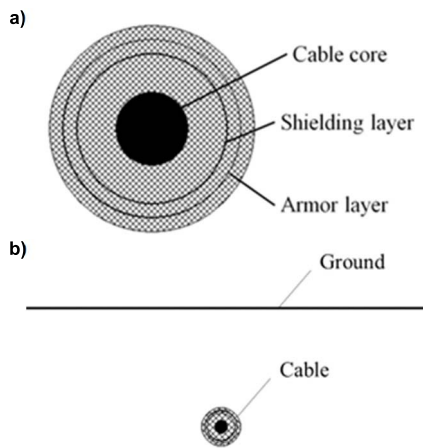

FIGURE 3. LCC model of single-core cable. a) Modeling structure diagram of single-core cable. b) Cable laying position diagram.

C. SIMULATION SETTING OF THREE-PHASE SINGLE-CORE CABLE

The single-core cable model is established by taking the cable in Table 1 as an example. On this basis, it is necessary to

modify some parameters to meet the simulation requirements of three-phase cables. It is necessary to set the number of single-core cables to 3 and the number of phases to 9.

For the simulation of three-phase cables, it is necessary to discuss the calculation methods of zero-sequence and positive-sequence parameters of three-phase single-core cables, calculate the electrical transposition (Snaking), and select the matrix output in lis file (Matrix output). Ground the sheath, all shields, then the total number is 3. The arrangement is that three single-core cables are placed horizontally under the surface of 1m, with 0.5m intervals, as shown in Fig. 4.

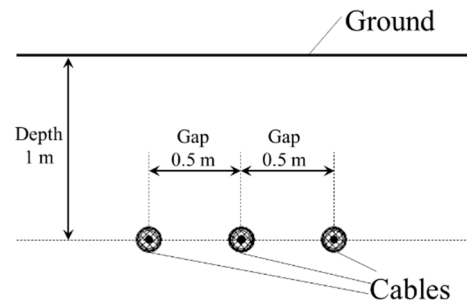

FIGURE 4. The arrangement of three-phase single-core cables.

III. THEORETICAL MODEL

A. IMPEDANCE CALCULATION

Through ATP calculation, the impedance  $Z$  and admittance matrix  $Y$  of the three-phase balance of the single-core cable are obtained. But when calculating the sequence parameters, the transformation matrix usually used for the balance matrix is not used. The transformation matrix used is  $T_i$ . According to the transformation matrix  $T_i$ , the transformed modulus impedance matrix  $T_i^T Z T_i$  is obtained by using other mathematical calculation tools. Similarly, the modulus admittance matrix is  $T_i^{-T} Y T_i^{-T}$ .

The zero-sequence and positive-sequence impedances of the cable can be obtained by matrix transformation, and can also be calculated by formula (1) and formula (2) respectively.

$$Z_0 = Z_s + 2Z_m \tag{1}$$

$$Z_1 = Z_s - Z_m \tag{2}$$

In the formula,  $Z_0$  is the zero-sequence impedance of the cable;  $Z_1$  is the positive-sequence impedance of the cable;  $Z_s$  is the diagonal element of the cable impedance matrix;  $Z_m$  is the non-diagonal element of the cable impedance matrix.

B. CURRENT CALCULATION

In the metal shielding layer of the cable, the transient ground current is mainly composed of the capacitive current  $I_c$  and the induced circulating current  $I_s$ .

In this paper, the single-core cable is used, and a capacitance will be formed between the cable core and the metal shielding layer of the large-length single-core cable, so the grounding capacitance current  $I_c$  will be formed under the action of the AC voltage. The capacitor uses the cable core and the metal shielding layer as the two poles, and the insulating layer is the capacitor medium. The capacitor current  $I_c$  can be expressed by formula (3),

$$I_c = j\omega CU_0l \quad (3)$$

In the formula,  $j$  is the imaginary unit;  $\omega$  is the angular frequency;  $C$  is the cable capacitance per unit length;  $U_0$  is the phase voltage of the core wire;  $l$  is the cable length.

When the metal shielding layer fails, the circulating current of the faulty phase will increase significantly. At the same time, the other two-phase sheaths have no multi-point grounding, and the circulating current can be ignored. At this time, the circulating current of the faulty phase can be expressed by formula (4),

$$I_s = \frac{E_1 - E_2}{R + jX + R_1 + R_2 + R_3} \quad (4)$$

In the formula,  $E_1$  is the induced potential generated in the metal shielding layer,  $E_2$  is the induced potential generated by the other two-phase core wires to the faulty phase metal shielding layer,  $R$  and  $X$  are the resistance and self-inductance of the metal shielding layer, respectively,  $R_1$  is the metal shielding layer. The grounding resistance when the shielding layer fails,  $R_2$  is the direct grounding of the metal shielding layer, and  $R_3$  is the ground resistance.

#### IV. IMPEDANCE ANALYSIS IN CABLE

##### A. GROUNDING LINE CONSTRUCTION

Cables have different grounding methods, namely grounding at one end, grounding at both ends, and cross-connecting grounding (one complete transposition, two complete transpositions). Different grounding methods will bring different impedances. In engineering, zero-sequence and positive-sequence parameters are used for power flow, stability, and short-circuit calculations. In this paper, ATP is used to build grounding lines to calculate zero-sequence and positive-sequence parameters of cables to verify the accuracy of the model. The specific grounding circuit is shown in Fig. 5.

It can be seen from Fig. 5 that the first line shows that the shielding layer and the armor layer are only grounded at one end. The second line shows that the shielding layer and the armor layer are grounded at both ends. The third line shows the shielding layer and armor layer cross interconnection, and both ends are grounded. The fourth line and the third line grounding mode is the same, two complete transposition. The grounding line was set up in ATP to simulate the grounding characteristics of the cable. The cable model adopted the LCC model of the three-phase single-core cable set up above. The left end of all grounding modes was connected to the current source 2 of 1A. The circuit used the current meter 3 to calculate the voltage of the left end, and the right end

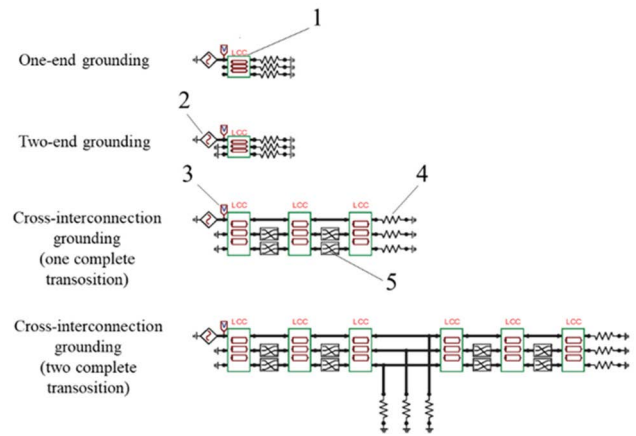

FIGURE 5. The wiring diagram of different grounding modes. 1-LCC model of three-phase single-core cable; 2-Current source; 3-Voltmeter; 4-Resistance; 5-Cross Connection Module.

was uniformly grounded. According to different grounding modes, grounding and non-grounding were selected at the left end, as shown in Fig. 6. Cross-connected grounding was divided into one complete transposition and two complete transpositions. Cross-connected connection module 5 was used for cross transposition.

##### B. IMPEDANCE COMPARATIVE ANALYSIS OF POSITIVE AND ZERO SEQUENCE

The impedance values of different grounding modes can be obtained by simulation on the built grounding circuit diagram shown in Fig. 6, as shown in Table 2.

TABLE 2. Impedance values of different grounding modes (Unit:  $(\Omega \cdot m^{-1})$ ).

Grounding mode	Zero-sequence impedance of cable $Z_0$	Positive sequence impedance of cable $Z_1$
One-end grounding	$6.442 \times 10^{-5} + 6.546 \times 10^{-4}i$	$1.523 \times 10^{-5} + 2.176 \times 10^{-4}i$
Two-end grounding	$2.378 \times 10^{-5} + 6.903 \times 10^{-5}i$	$2.383 \times 10^{-5} + 6.908 \times 10^{-5}i$
Cross-interconnection grounding (one complete transposition)	$1.803 \times 10^{-5} + 1.679 \times 10^{-4}i$	$1.521 \times 10^{-5} + 2.173 \times 10^{-4}i$
cross-interconnection grounding (two complete transposition)	$3.606 \times 10^{-5} + 3.357 \times 10^{-4}i$	

In normal operation, the positive sequence current flows through the cable core, so that the induced voltage in the shielding layer counteracts each other, and the induced current will decrease. If the zero sequence current flows through the cable core, the cross transposition will not cause any influence.



This can also be seen in the impedance calculation parameters of cables. In the calculation process of positive sequence impedance, the cables are transposed. The ‘snaking’ is selected in the parameters of the cable. In Fig. 5, the first is the case where only one end of the shielding layer and the armoring layer is grounded, and the second is the case where both ends of the shielding layer and the armoring layer are grounded. Since there is current in the shielding layer, the resistance  $2.383 \times 10^{-5} \Omega$  when both ends are grounded is greater than  $1.523 \times 10^{-5} \Omega$  for single-ended grounding, and the inductance  $6.908 \times 10^{-5} \text{ H}$  is less than  $2.176 \times 10^{-4} \text{ H}$  for single-ended grounding. The third is the case where the shielding layer and the armoring layer are cross-connected, and both ends are grounded, and the corresponding impedance is exactly the same as that of the single-ended grounding.

For zero sequence impedance, the change trend of impedance after single-end grounding and two-end grounding of shielding layer and armor layer is the same as that of positive sequence impedance. Because there is a current in the shielding layer of two-end grounding, the resistance increases and the inductance decreases. When the shielding layer and the armor layer are interconnected, the corresponding impedance and the grounding impedance at both ends are the same, because the current flowing through the shielding layer is the same in both cases. The fourth line and the third line grounding mode is the same, two complete transposition. After two cross transpositions, the impedance value is  $3.606 \times 10^{-5} + 3.357 \times 10^{-4}i$ . Since the conductor length required for two complete transpositions is twice that of one complete transposition, the impedance value is also twice that of one complete transposition.

Through positive sequence and zero sequence analysis, it can be concluded that the model conforms to the basic laws of electricity and the grounding characteristics of the cable, which verifies the feasibility of the model and facilitates subsequent calculations.

**C. CANCEL THE IMPEDANCE ANALYSIS AFTER THE CABLE CORE TRANSPOSITION**

The thickness of the cable shielding layer was increased from 0.12 mm to 0.42 mm, and the cable core transposition was removed. After the cable core transposition was removed, a cable core interconnection was set as a comparison. For the analysis, compared to “ $V_{re} + jV_{im}$ ”, using the form of “ $|V|/\delta$ ” can compare and observe the grounding characteristics better. The impedance values of phase A, phase B and phase C of the cable are listed below when the thickness is 0.12 mm and 0.42 mm respectively, see Tables 3 and Table 4 for details.

According to the positive-sequence parameters, in the case of one-end grounding, the impedance between the three phases of the cable is not equal, which is because the cable core is not displaced, and the difference between the maximum and the minimum impedance is about  $2.74 \times 10^{-5} \Omega \cdot \text{m}^{-1}$ . The case of two-end grounding is

**TABLE 3. Positive sequence impedance value when a thickness of 0.12 mm for the cable shielding layer (Unit: ( $\Omega \cdot \text{m}^{-1}$ )).**

Grounding mode	Phase A impedance	Phase B impedance	Phase C impedance
One-end grounding	$2.310 \times 10^{-4}$ $\angle 76.7$	$2.036 \times 10^{-4}$ $\angle -34.3$	$2.259 \times 10^{-4}$ $\angle -144.1$
Two-end grounding	$7.308 \times 10^{-5}$ $\angle 71.1$	$7.312 \times 10^{-5}$ $\angle -48.9$	$7.304 \times 10^{-5}$ $\angle -168.1$
Cross-interconnection grounding of the shielding layer and the armor layer	$2.353 \times 10^{-4}$ $\angle 80.1$	$1.887 \times 10^{-4}$ $\angle -34.6$	$2.320 \times 10^{-4}$ $\angle -147.5$
Cable core cross-connected grounding	$2.179 \times 10^{-4}$ $\angle 86.0$	$2.179 \times 10^{-4}$ $\angle -34.0$	$2.179 \times 10^{-4}$ $\angle -154.1$

similar to the one-end grounding. Three phases’ resistance of two-end grounding cable are larger than that of one-end grounding cable. The difference between the maximum and the minimum impedance is  $3 \times 10^{-7} \Omega \cdot \text{m}^{-1}$ . However, the impedance value is larger than the other grounding modes. In the case of cross-interconnection between the shielding and armor layers, three phases’ impedance parameters of the cable are also unequal, and the difference between the maximum and the minimum impedance is about  $4.66 \times 10^{-5} \Omega \cdot \text{m}^{-1}$ . When the cable cores are cross-connected, the three-phase impedance value of the cable is equal, which is a balanced transposition method, and the grounding effect is the best. The impedance voltage of 220 kV power devices reaches 12% to 14%, and the impedance voltage of several grounding methods is within a reasonable range.

**TABLE 4. Positive sequence impedance values with a thickness of 0.42 mm for the cable shielding layer (Unit: ( $\Omega \cdot \text{m}^{-1}$ )).**

Grounding mode	Phase A impedance	Phase B impedance	Phase C impedance
One-end grounding	$2.310 \times 10^{-4}$ $\angle 76.7$	$2.036 \times 10^{-4}$ $\angle -34.3$	$2.259 \times 10^{-4}$ $\angle -144.1$
Two-end grounding	$6.791 \times 10^{-4}$ $\angle 71.1$	$6.791 \times 10^{-4}$ $\angle 48.9$	$6.788 \times 10^{-4}$ $\angle -168.1$
Cross-interconnection grounding of the shielding layer and the armor layer	$2.353 \times 10^{-4}$ $\angle 80.1$	$1.887 \times 10^{-4}$ $\angle -34.6$	$2.320 \times 10^{-4}$ $\angle -147.5$
Cable core cross-connected grounding	$2.179 \times 10^{-4}$ $\angle 86.0$	$2.179 \times 10^{-4}$ $\angle -34.0$	$2.179 \times 10^{-4}$ $\angle -154.1$

From the comparison of Table 3 and Table 4, it can be concluded that the impedance voltage value of the grounding at both ends has a small increase, which is almost negligible, and the impedance values of other grounding methods remain

unchanged. It shows that the change of the thickness of the shielding layer has little change in the impedance value of the cable. The following is a further analysis of the cable current to determine a better grounding method.

**V. ANALYSIS OF THE CURRENT IN CABLE**

**A. CONSTRUCTION OF GROUNDING LINE**

Now the small resistance of short circuit was replaced with current measuring instrument to compare the current flowing through the line. Schematic diagram of ammeter wiring is shown in Fig. 6.

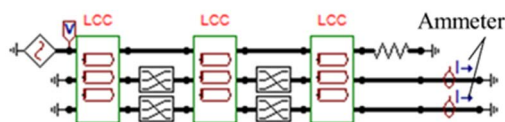

**FIGURE 6. Schematic diagram of the ammeter wiring.**

To further explore the characteristics of different grounding methods, the grounding line as shown in Fig. 7 was established. The cable core cross-connected application is less, and its cost is higher, but the grounding characteristics are better. This study listed this line as a comparison to verify the feasibility of cross-interconnection grounding of the shielding layer and the armor layer.

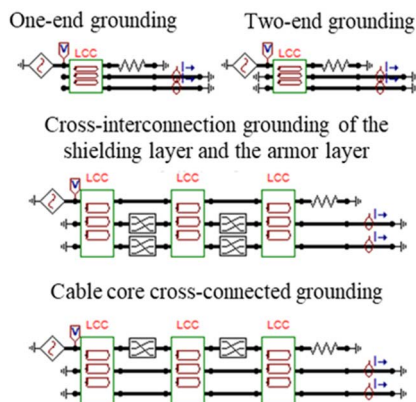

**FIGURE 7. Schematic diagram of the ammeter wiring.**

**B. COMPARATIVE ANALYSIS OF POSITIVE AND ZERO SEQUENCE**

According to the wiring mode of the diagram above, the current values of different grounding modes can be obtained, as shown in Table 5. By comparing the current value of different grounding methods, the best grounding method was better selected.

First, the state of positive sequence was analyzed. When the shielding layer and the armor layer are grounded, the current flowing through the shielding layer is 0.306 A, and the current source current is 1 A, so 30% of the current in the shielding layer is 0.843 A current in the armor layer.

**TABLE 5. Positive sequence current values of different grounding modes (Unit: A).**

Grounding mode	Shielding layer current	Armor layer current
One-end grounding	/	/
Two-end grounding	0.306	0.843
Cross-interconnection grounding of the shielding layer and the armor layer	$5 \times 10^{-9}$	$3 \times 10^{-7}$
Cable core cross-connected grounding	$8 \times 10^{-9}$	$3 \times 10^{-7}$

If both the shielding layer and the armor layer are cross-transposition, the current in the shielding layer is  $5 \times 10^{-9}$  A, the current in the armor layer is  $3 \times 10^{-7}$  A. It can be seen that the effect of cross-transposition. The current is greatly reduced, and the grounding characteristics are good.

Table 6 shows the zero-sequence current values for different grounding methods.

**TABLE 6. Zero sequence current values of different grounding modes (Unit: A).**

Grounding mode	Shielding layer current	Armor layer current
One-end grounding	/	/
Two-end grounding	0.304	0.833
Cross-interconnection grounding of the shielding layer and the armor layer	0.1	0.277
Cable core cross-connected grounding	0.1	0.277

Then, the situation of zero sequence current in the circuit was analyzed. This transposition has no effect on the current in the shielding layer and the armor layer. The current in the shielding layer is 0.1 A, accounting for about 10% of the current in the circuit. The current in the armor layer is 0.277 A, which is about 30%.

In addition to the above cross-interconnection of the shielding layer and the armor layer, there is another transposition way in the cross-interconnection of cable grounding is that the shielding layer and armor layer are not cross-interconnection but the cable core for cross-interconnection. The results showed that there was no change from the cross-interconnection of the shield layer and the armor layer, because the cable core was replaced when setting the single-core cable above.

**C. COMPARISON ANALYSIS OF CURRENT AFTER CANCELING CABLE CORE TRANSPOSITION**

Next the thickness of cable shielding layer was increased from 0.12 mm to 0.42 mm, and the cable core transposition was removed. After the cable core transposition was removed, a cable core interconnection was set as a comparison. Positive sequence current values can be obtained when the cable shield

**TABLE 7. Positive sequence current value when the thickness of cable shielding layer is 0.12 mm (Unit: (A)).**

Grounding mode	Shielding layer current	Armor layer current
One-end grounding	/	/
Two-end grounding	0.306	0.827
Cross-interconnection grounding of the shielding layer and the armor layer	0.001	0.009
Cable core cross-connected grounding	$8 \times 10^{-9}$	$3 \times 10^{-7}$

**TABLE 8. Positive sequence current value when the thickness of cable shielding layer is 0.42 mm (Unit: (A)).**

Grounding mode	Shielding layer current	Armor layer current
One-end grounding	/	/
Two-end grounding	0.644	0.536
Cross-interconnection grounding of the shielding layer and the armor layer	0.003	0.008
Cable core cross-connected grounding	$9 \times 10^{-9}$	$3 \times 10^{-7}$

thickness was 0.12 mm and 0.42 mm by ATP simulation, as shown in Table 7 and Table 8.

According to the comparative analysis of Table 7 and 8, increasing the thickness of the shielding layer will increase the current of the shielding layer. The shielding layer is designed to control the cable from failing to work normally due to insulation damage, mechanical damage, fire or electrical interference. Therefore, the increase of current can't be ignored to increase the thickness of shielding layer, and in the design of cable should pay attention to the thickness of the cable layer.

According to Table 8, in the case of eliminating the cable core transposition, the current of the shielding layer and armor layer is much reduced when they are cross-interconnection grounding than when both ends are grounded. According to the simulation results, by comparing three phases, the size and phase of the current flowing through the cable shielding layer are same. When the cable core is cross-connected at high pressure conditions, the current flowing through the shielding layer and the armor layer is the minimum and negligible. The effect of cable core cross-connected grounding is better, which is an ideal cross-interconnection way, but in the process of connection needs a large number of metal materials, and its cost is much higher than cross-interconnection grounding of the shielding layer and the armor layer.

## VI. CONCLUSION

Based on ATP-EMTP, this paper made simulation and analysis of different grounding modes of cable, and compared three grounding modes of one-end grounding, two-end

grounding and cross-interconnection grounding (cable core grounding, shielding layer and armor layer grounding). Finally, the impedance and current characteristics of cable were analyzed, and set the different shielding thickness to choose the appropriate grounding. This study provides guidance for the grounding method of cable laying work in the early stage, and provides reference for other cable related research.

- 1) According to the relevant standards, the parameters of the single-core cable was selected. Then the three-phase cable LCC model was established in the ATP.
- 2) Grounding lines with different grounding methods were built. They were calculated and analyzed from zero order and positive order to verify the accuracy of the model.
- 3) After confirming the model, the transposition of the cable core was cancelled. Then the impedance characteristics of the cable were analyzed. The results show that several grounding methods have little difference, and they all meet the requirements;
- 4) According to the above grounding model, the current characteristics of the cable after the transposition of the cable core cancelled were analyzed. The results show that the ground current characteristic of the cross-connection of the cable core is the best, and the loss during operation is almost negligible. However, under the premise of considering the cost, the cross-connected grounding of the shielding layer and the armored layer is more in line with the requirements of grounding characteristics.

## REFERENCES

- [1] Z. Jin, "Research on outgoing power frequency and operating overvoltage of 220 kV long submarine cable in offshore wind farm," *Electric Porcelain Lightning Arrester*, vol. 1, pp. 47–53, Feb. 2020, doi: [10.16188/j.isa.1003-8337.2020.01.008](https://doi.org/10.16188/j.isa.1003-8337.2020.01.008).
- [2] X. Xu, X. Chen, F. Meng, and A. Paramane, "Performance of different grounding systems of 500 kV XLPE long submarine cables based on improved multiconductor analysis method," *Electric Power Syst. Res.*, vol. 202, Jan. 2022, Art. no. 107608, doi: [10.1016/j.epsr.2021.107608](https://doi.org/10.1016/j.epsr.2021.107608).
- [3] Y. Zhang, R. Luo, and D. Tian, "110 kV submarine cable-overhead line lightning strike overvoltage analysis," *Electric Porcelain Lightning Arrester*, vol. 2, pp. 14–19, Apr. 2022, doi: [10.16188/j.isa.1003-8337.2022.02.003](https://doi.org/10.16188/j.isa.1003-8337.2022.02.003).
- [4] D. Lu, L. Zheng, and J. Zh, "Discussion on grounding method of high-voltage submarine cable," *Opt. Fiber Cable Appl. Technol.*, vol. 2, pp. 27–29, Mar. 2022, doi: [10.19467/j.cnki.1006-1908.2022.02.009](https://doi.org/10.19467/j.cnki.1006-1908.2022.02.009).
- [5] S. Xie, Z. Gao, and X. Jianliang, "Grounding scheme design of high-voltage bridge-accompanying cables for sea-crossing bridges," *Electr. Technol.*, vol. 13, pp. 44–47, Jul. 2022, doi: [10.19768/j.cnki.dgjs.2022.13.012](https://doi.org/10.19768/j.cnki.dgjs.2022.13.012).
- [6] G. Chen, Y. Tang, and X. Wang, "Multi-point grounding fault simulation of high-voltage cable metal sheath based on ATP," *High-Voltage Electr. Appliances*, vol. 50, no. 4, pp. 49–53&60, Jun. 2014, doi: [10.13296/j.1001-1609.hva.2014.04.009](https://doi.org/10.13296/j.1001-1609.hva.2014.04.009).
- [7] R. Liu, "Research on multi-point grounding fault of transmission cable shield based on ATP-EMTP," *Electr. Eng.*, vol. 5, pp. 64–66&70, Mar. 2022, doi: [10.19768/j.cnki.dgjs.2022.05.016](https://doi.org/10.19768/j.cnki.dgjs.2022.05.016).
- [8] Z. G. Zhang, Z. G. Ding, Y. J. Dong, Z. L. Yuan, H. C. Tao, and J. J. Wang, "The study of burial depth and risk assessment of submarine power cable," in *Proc. GMEE*, Beijing, China, 2018, pp. 399–406.



[9] X. Lu, J. Liu, and S. Feng, "No-load input simulation of submarine cable based on ATP," *China Mar. Platform*, vol. 32, no. 2, pp. 41–48&54, Apr. 2017.

[10] C. Zhang, H. Rui, and H. Liu, "Simulation analysis of overvoltage characteristics of single-phase ground fault sheath of high-voltage single-core cable," *Electr. Meas. Instrum.*, vol. 55, no. 11, pp. 115–119, Jun. 2018.

[11] Q. Wang, F. Ji, and Z. Fan, "Study on influence of cross interconnection cable on fault power frequency current," *Electr. Eng.*, vol. 7, pp. 81–84, Apr. 2022, doi: [10.19768/j.cnki.dgjs.2022.07.022](https://doi.org/10.19768/j.cnki.dgjs.2022.07.022).

[12] L. Liu, "Research on calculation method of temperature field and carrying flow of bridge laying cable group," M.S. thesis, Dept. Electron. Eng., HEBUST Univ., Hebei, China, 2015.

[13] B. Feng, G. Liu, and H. Cai, "Simulation analysis of induced voltage of standby submarine cable conductor in Hainan network project," *Electr. Eng.*, vol. 5, pp. 106–108, Mar. 2020, doi: [10.19768/j.cnki.dgjs.2020.05.040](https://doi.org/10.19768/j.cnki.dgjs.2020.05.040).

[14] C. Lin, X. Chen, and X. Wen, "Research on power frequency overvoltage of hybrid transmission lines in 220 kV offshore wind farms," *Hydropower Energy Sci.*, vol. 38, no. 2, pp. 197–201, Feb. 2020.

[15] Y. Li, *Electromagnetic Transient Simulation and Application of Transmission Lines*. Beijing, China: China Water Resources and Hydropower Press, 2019, pp. 222–258.



**YOUCONG HUANG** received the master's degree. He was a senior engineer and a technician. He is currently the Director at the State Grid Fujian Electric Power Research Institute Equipment Technology Research Center Transmission Technology Room. He was a part-time Trainer at the State Grid Fujian Electric Power Company Ltd. He has published nine papers and monographs, received 17 patents, and drafted 17 technical standards. He was engaged in high voltage cable and transmission line maintenance technology research.

He served as a member for the Technical Committee of Power Cable and Accessories of the National Transmission and Distribution Technology Cooperation Network (EPTC), the Transmission Line Professional Committee of the Fujian Provincial Institute of Electrical Engineering, and the Non-Stop Technology Professional Committee of the Fujian Provincial Institute of Electrical Engineering.



**ZHIWEI FU** was born in September 1985. He was a senior engineer and the State Grid Company Outstanding Expert Talent. He is currently with the State Grid Fujian Electric Power Company Ltd., Equipment Management Department as the Deputy Director of the Transmission Department, where he is responsible for the Fujian company overhead and cable transmission line intelligent transportation and inspection system construction and new technology application research, trans-

mission and transformation equipment overvoltage and anti-fouling flash management, and other work. He is familiar with the power grid operation management, equipment maintenance, installation tests, power grid regulation, other power production process management, technical supervision business. He has participated in a number of state grid companies and provincial companies' science and technology projects such as "Research on Operation and Maintenance Strategy of High-voltage Large-Capacity Flexible HVDC Transmission" and "Research on the Application of New Technologies for Condition Detection and Diagnosis of High-Voltage Cables." He has published nearly ten core journals of EI retrieval and Chinese. Many times he won the provincial power company safety production advanced individual and outstanding party member of the provincial power company. He has won two first prizes, one second prize, and two third prizes of Fujian Provincial Science and Technology Progress in the past five years; and four third prizes of "Five Small Innovations" in Fujian.



**ZHONGNAN ZHENG** was born in Fuzhou, Fujian, China, in 1991. He received the B.S. and M.S. degrees in electric engineering from the University of Wuhan, in 2016.

In August 2016, he entered the Fujian Electric Power Research Institute to participate in the work, and his current position is the Primary Division of Power Cable Evaluation. He has professional quality and business ability. He has completed transformer gas physical leakage live detection, cable grounding circulation detection, and 1000kV Rongcheng transformer GIS withstand voltage test. In 2018, as the coach of the bureau release testing project of the national power cable installation skills and testing competition in our province, he participated in the scientific research project of the State Grid Headquarters Science and Technology Project "Key Technologies and Applications of Power Cable Fire Mechanism, Monitoring and Prevention." He is the author of more than ten inventions. His research interests include high voltage cable, insulator, and transmission line.



**TUO SHI** was born in Xuzhou, China, in 1999. He received the bachelor's degree in vehicle engineering from the Nanjing Institute of Technology, in June 2021. In September 2021, he entered the Graduate School of Nanjing Institute of Technology and is currently in the second grade of graduate students. He has published two articles in provincial journals at the postgraduate level. During his undergraduate degree, he has won the first-class scholarship and other honors for many times.



**YING ZHANG** was born in Fujian, China, in 1995. She received the bachelor's degree in electrical engineering from the China University of Mining and Technology, in 2018, and the master's degree in electrical engineering from Xi'an Jiaotong University, in 2021. From 2021 to 2022, she worked at the State Grid Fujian Electrical Power Research Institute. She was engaged in high-voltage power cable and overvoltage simulation research.



**SHAOKANG CHEN** was born in Fujian, China, in 1996. He received the M.E. degree from Fu'zhou University, Fu'zhou, China, in 2021. He has been worked at the Electric Power Research Institute of State Grid Fujian Electric Power Company Ltd., since 2021. His current research interests include overvoltage protection and insulation technology.



**JING JIAO** was born in Xuzhou, China, in 1998. She graduated the bachelor's degree in control engineering of transportation equipment from the Nanjing Institute of Technology, in June 2022. During the undergraduate period, she has participated in the Undergraduate Science and Technology Innovation Training Project. In September 2022, she entered the Graduate School of Nanjing Institute of Technology for study, and is currently in the first grade of graduate students. During her undergraduate she has won honors such as national inspirational scholarships, school-level special scholarships, and school-level three-good students.

...