

RESEARCH ARTICLE

Evaluation Index and Evaluation Method of Three-Phase Imbalance Treatment Effect Based on Commutation

JIE CHEN¹, FEIYAN ZHOU¹, LINGYUN GU¹, HUI YIN¹, LI ZHANG², AND CHAOFEI GAO^{1,2}¹Beijing Key Laboratory of Distribution Transformer Energy-Saving Technology, China Electric Power Research Institute, Beijing 100192, China²Beijing Information Science and Technology University, Beijing 100192, China

Corresponding author: Chaofei Gao (gaocf@bistu.edu.cn)

This work was supported by the Open Fund of Beijing Key Laboratory of Distribution Transformer Energy-Saving Technology, China Electric Power Research Institute, under Grant PDB51202001511.

ABSTRACT With the construction and development of the distribution Internet of things in China, the three-phase imbalance treatment in the distribution area has gradually attracted attention as an optional function, and a large number of intelligent terminal manufacturers have begun to study this aspect. In this paper, research is carried out on the three-phase imbalance treatment function based on commutation control. The evaluation index system of imbalance treatment based on commutation is proposed in combination with the imbalance harm and the influence of treatment, and the three-phase imbalance treatment effect is evaluated by combining the analytic hierarchy process and improved entropy weight method. An example is given to verify the effectiveness of the evaluation method proposed in this paper.

INDEX TERMS Three-phase load imbalance, intelligent terminal, index system, analytic hierarchy process, improved entropy weight method.

I. INTRODUCTION

With the gradual upgrade and expansion of the distribution network in China, the problems of insufficient planning and management, the surge and unbalanced distribution of the single-phase load, and the time characteristics of the load make the three-phase load imbalance problem of the low-voltage distribution network more prominent. Serious three-phase imbalance will increase the power loss of the low-voltage distribution network, damage the power equipment, and seriously affect the quality of the power supply and the economic operation of the low-voltage distribution network [1], [2]. Therefore, the in-depth study of the three-phase imbalance treatment method in the distribution network can ensure good power quality, effectively reduce equipment and line losses, and reduce the occurrence of destructive accidents, which has important theoretical research significance and practical application value for the economically safe operation of distribution networks.

The associate editor coordinating the review of this manuscript and approving it for publication was Shun-Feng Su¹.

At present, the methods to deal with three-phase imbalance mainly include load phase sequence balance, distribution network reconfiguration, and three-phase imbalance compensation devices. Each treatment method has its own advantages and disadvantages, and the scope of application is also different [3], [4], [5], [6], [7], [8], [9]. The imbalance treatment method based on commutation switch collects the data of the terminal by analyzing the electricity consumption information, the optimal control strategy is used to switch the phases of a certain number of single-phase users, and the load redistribution on the three-phase line is realized [8], [9].

The construction of the distribution Internet of Things can realize the real-time monitoring of the line load, and the status of the distribution line load switch can be visualized and controlled, which provides the hardware foundation and data support for the three-phase imbalance treatment based on the commutation switch. At the same time, the development of advanced application analysis functions in the intelligent fusion terminal can meet the power supply service and management needs of the distribution area in different scenarios, which is the development demand of the distribution Internet

of Things [11], [12]. At present, although the three-phase imbalance treatment function is an elective requirement for intelligent fusion terminals, an increasing number of intelligent terminal manufacturers are gradually developing this application.

Judging from the literature, there are many imbalanced treatment commutation strategies, and the treatment goals are also quite different, resulting in different treatment effects. However, there is a lack of evaluation at the national and industry levels regarding the effects of various strategies. The State Grid's "Notice of the State Grid Operation and Maintenance Department on Carrying out the Treatment of Three-phase Load Imbalance Problems in the Distribution Area" (referred to as the "Notice") only gives the scope of treatment; that is, the continuous overlimit time for more than 1 hour in one day is set as 1 overlimit day. The distribution area with an average loading rate greater than 20% and more than 5 days exceeding the limit in a single month should be included in the scope of treatment. There is a lack of what standard to achieve after load adjustment and the basis for evaluating the effect after treatment. Therefore, it is very important to study the treatment effect index system of the treatment method based on load commutation and to evaluate the treatment effect.

Although there is a lack of research related to effect evaluation on three-phase imbalance treatment, there are many mature evaluation theories and methods used in various fields of power systems, such as the comprehensive evaluation of power quality combined with subjectivity and objectivity, fuzzy mathematics evaluation methods, and radar chart methods [12], [13], [14], [15], [16]. Reference [13] establishes a scientific and reasonable evaluation index system of distribution network adaptability and combines the analytic hierarchy process (AHP) and entropy weight method to determine the index weight. Reference [14] combines AHP and the entropy weight method to comprehensively evaluate the reliability of the power consumption of a distribution network. Reference [15] assesses the power quality of distorted distribution networks incorporating renewable distributed generation systems based on an analytic hierarchy process. Reference [16] presents a data-driven abnormality assessment algorithm for low-voltage power consumers based on the CRITIC method and the improved radar chart method. Reference [17] uses the minimum deviation combination weight method to calculate the optimal combination weight of each evaluation index and uses the improved radar chart method to comprehensively evaluate the power quality of the distribution system. Based on extensive literature analysis, the key to the evaluation of the three-phase imbalance treatment effect lies in the construction of the index system and the selection of the evaluation method.

Aiming at the problem that there is, at present, neither an evaluation index nor an evaluation method for three-phase imbalance treatment based on commutation, this paper starts from the imbalance influence and the imbalance treatment mechanism of load balancing, proposing an evaluation index

system for three-phase imbalance treatment based on commutation switch. The subjective weight of each index is given by the analytic hierarchy process, and the objective weight of each index is determined by the improved entropy weight method while overcoming the defect of polarizing index importance. The three-phase imbalance treatment based on commutation is comprehensively evaluated by combining subjectivity and objectivity.

II. THREE-PHASE IMBALANCE TREATMENT EFFECT EVALUATION INDEX SYSTEM

A. THE HARM OF THREE-PHASE IMBALANCE AND ITS REGULATION BENEFIT INDEX

1) THE HARM OF THREE-PHASE IMBALANCE

When a serious three-phase imbalance occurs in the outlet of the distribution area, it increases the loss of the power grid, endangers the electrical equipment and lines, causes the malfunction of the protection device, brings economic losses to the power supply enterprise, and affects the power quality of the users. The root cause of its harm is mainly reflected in the increase in current loss and voltage deviation caused by imbalance.

The increase in current loss caused by imbalance includes the load loss of distribution transformers in the station area, the loss of low-voltage lines, and the loss of high-voltage lines in the station area. The increase in loss not only directly affects the economic benefits of power supply enterprises but also causes the superheating of equipment and lines. It brings about problems such as equipment damage and line failure, which indirectly affect the safety and economy of the power supply. The factor that affects the degree of loss is the current size of each phase. Therefore, not only the degree of imbalance but also the size of the current, that is, the loading rate, should be considered when performing imbalance treatment.

The three-phase load imbalance causes voltage deviation in each phase, which causes a certain degree of damage to the high- and low-voltage equipment. The calculation of the voltage deviation is not related to the size of the current but only to the imbalance degree of the current.

Therefore, the treatment effect index must be comprehensively considered from the two aspects of imbalance degree and loading rate.

2) REGULATION BENEFIT INDEX

The regulation benefit is defined as a first-level index of three-phase imbalance treatment, reflecting the benefits that can be brought after treatment. There are two second-level indices, namely, the imbalance degree and the imbalance loss coefficient.

Imbalance degree, k : The imbalance degree of the three-phase current, according to the State Grid Corporation's enterprise standard (Q/GD W519-2010) "Procedure for distribution network", can be calculated as

$$k = \frac{I_{\max} - I_{\min}}{I_{\max}} \times 100\% \quad (1)$$

In the formula, I_{max} is the significant value of the maximum current in three phases, and I_{min} is the significant value of the minimum current in three phases.

The imbalance loss coefficient, α , the product of the loading rate, and the imbalance degree reflect the influence of the current imbalance on the loss.

$$\alpha = k \times \beta \quad (2)$$

In the formula, β is the loading rate of the transformer.

The overall loss caused by imbalance is a function of the current of each phase and can be expressed as a function of the imbalance loss coefficient, α , that is, in the form of $loss = f(\alpha)$. The calculation of the loss value involves the loading rate, line topology, and line parameters, and it is difficult to calculate accurately. Therefore, this paper uses the imbalance loss coefficient, α , to replace the specific loss value as the evaluation index of the treatment effect.

B. THREE-PHASE IMBALANCE TREATMENT PRINCIPLE AND REGULATION COST INDEX BASED ON COMMUTATION

1) THREE-PHASE IMBALANCE TREATMENT PRINCIPLE BASED ON COMMUTATION

The three-phase imbalance treatment system in the distribution area is composed of an intelligent terminal and a phase commutation switch. As shown in Figure 1, the intelligent terminal detects the current transformer data at the outlet of the station area in real time. When the imbalance is judged, it communicates with the commutation switch to obtain the current data of each controllable load. The intelligent terminal controls the commutation unit to switch the single-phase load by optimizing the control strategy analysis and realizes the three-phase balance of the entire station area from the load side.

At present, the commutation switch combines the advantages of semiconductor devices and contactor switches, which avoids the problem of a large surge current caused by the contactor switch at the moment of load switching and greatly shortens the power supply interruption time during the commutation process. Even so, a certain degree of power supply interruption will occur during the commutation process. Frequent switching of the commutation switch will bring poor user experience and will affect the practical life of the commutation switch and other faults in the commutation process.

Therefore, when evaluating the effect of three-phase load imbalance treatment, it is necessary to take into account the influence introduced by the treatment process, that is, the possible losses caused by the treatment, namely, the regulation cost. In this paper, the commutation switch action is considered to represent the regulation cost.

2) THE REGULATION COST INDEX

The regulation cost is defined as a first-level index for three-phase imbalance treatment, which is mainly reflected by the action of the commutation switch. There are two second-level

indices under it, which are the total number of commutation switch actions and the degree of commutation switch action difference.

The total number of switch actions, n : the total number of actions of all commutation switches within the statistical time.

Switch action difference, m : the ratio of the maximum number of actions of a single commutation switch to the average number of actions of all commutation switches within the statistical time.

C. THE INDEX SYSTEM COMBINING REGULATION BENEFIT AND REGULATION COST

1) IMBALANCE TREATMENT INDEX SYSTEM

Although the "Notice" sets out the regulations for one over-limit day (continuous overlimit time for more than 1 hour in one day) and the conditions that the distribution area needs to be treated, nonetheless it does not specify what standards must be met after treatment. Therefore, various treatment strategies can easily achieve this index, such as taking action every 45 minutes to keep it from exceeding the limit continuously for 1 hour, but it cannot reflect the ultimate reduction in loss and the improvement in voltage quality. Longer treatment intervals (one action every 45 minutes) may not be able to guarantee the load balance state after treatment, while shorter treatment intervals (one action every 15 minutes) will bring about the frequent action of the commutation switch. Therefore, the three-phase imbalance treatment evaluation not only considers the treatment effect under the condition of a fixed load but should also consider the comprehensive treatment effect over a period of time.

Considering the treatment effect and the influence introduced in the treatment process, this paper divides the three-phase imbalance treatment index system into two first-level indices: Regulation benefit and regulation cost. The two first-level indices correspond to the two second-level indices. The treatment index system is shown in Figure 2.

2) THE CLASSIFICATION BASIS OF EACH INDEX

The second-level indices of regulation benefit are divided into five levels. Based on expert opinion, the threshold values for each level are shown in Table 1. Because it is a periodic evaluation, the specific value of the imbalance influence index after treatment is the statistical value of the time occupied by each level.

The second-level indices of regulation cost are also divided into five levels, and the threshold value of each level is determined through specific test cases. A three-phase imbalance test scheme is designed, in which six fixed loads and six adjustable loads can be set, each load has an adjustment range of 0–3 KW, and the adjustment step value is 0.1 KW. Given the load test data for a period of time, calculate all possible switch action combinations, count the action combinations with an imbalance loss coefficient greater than level 5 after adjustment, and then determine the threshold value of each

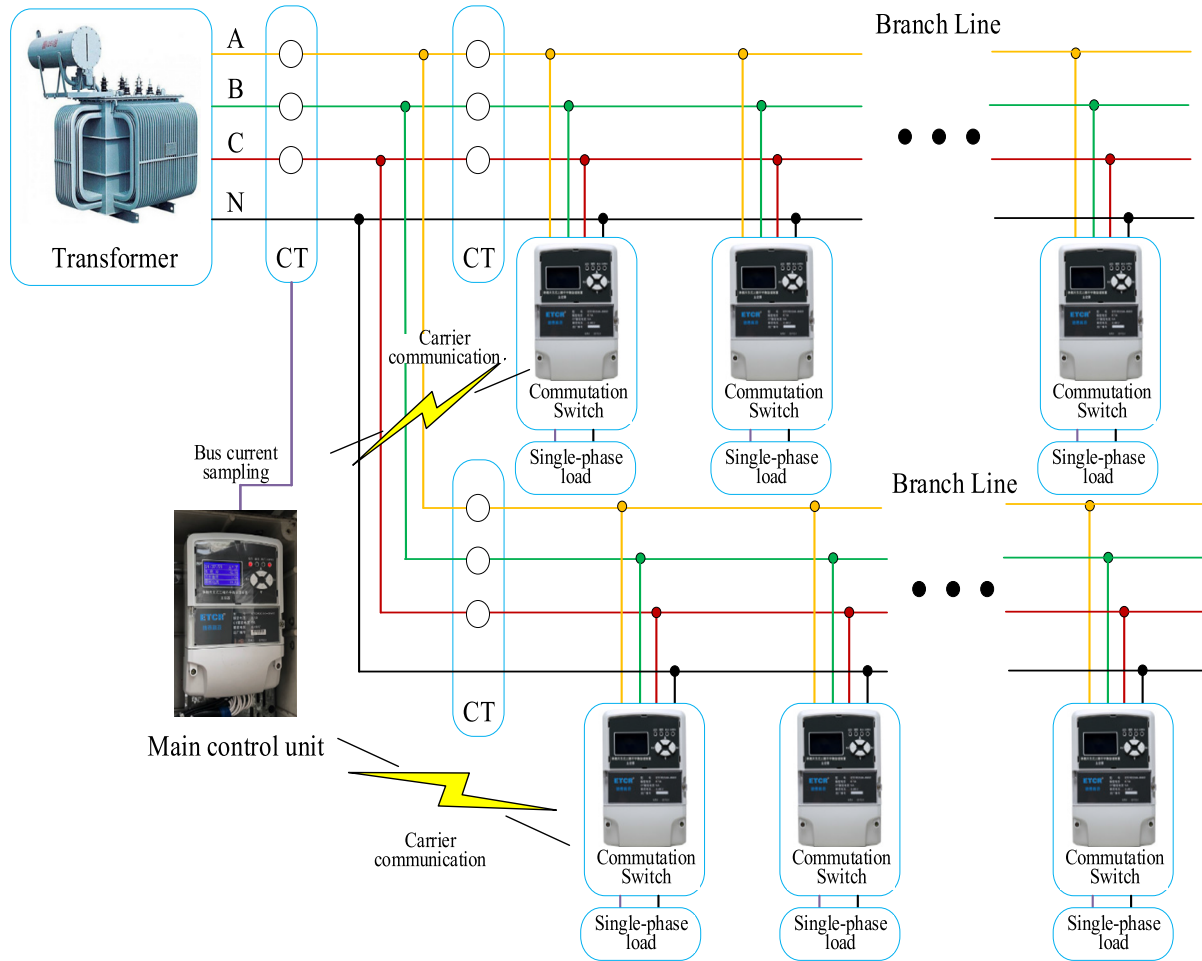

FIGURE 1. System diagram of the three-phase imbalance treatment of the distribution station area.

TABLE 1. Regulation benefit index of three-phase imbalance and its classification limit.

Evaluation indices		Three-phase imbalance treatment effect level				
First-level index	Second-level indices	Level 1	Level 2	Level 3	Level 4	Level 5
Regulation benefit	Difference degree	≤5%	≤10%	≤15%	≤30%	≥30%
	Imbalance loss coefficient	≤0.03	≤0.06	≤0.09	≤0.18	≥0.18

level for each second-level index. taking the index of the total number of switch actions as an example, there are 200 groups of switch action combinations, of which the lowest 5% of the total number of switch actions is considered to be level 1. Then, the total number of switch actions corresponding to the 10th group is regarded as the threshold value n_1 of the level 1 index. By analogy, the index threshold values at all levels can be obtained.

III. THE COMPREHENSIVE EVALUATION METHOD COMBINED WITH SUBJECTIVITY AND OBJECTIVITY

The effect of the three-phase imbalance treatment needs to be comprehensively evaluated from the following aspects:

the imbalance degree after treatment, the loss of power distribution area, and the number of switching actions. It is a multilevel and multi-index comprehensive evaluation. This paper uses the analytic hierarchy process and entropy weight method to determine the subjective and objective weight of each index in the evaluation of the imbalance treatment effect so that the final evaluation results are more objective and reasonable.

A. CALCULATION OF SUBJECTIVE WEIGHT BASED ON ANALYTIC HIERARCHY PROCESS

The analytic hierarchy process (AHP) is a hierarchical analysis method that combines qualitative and quantitative

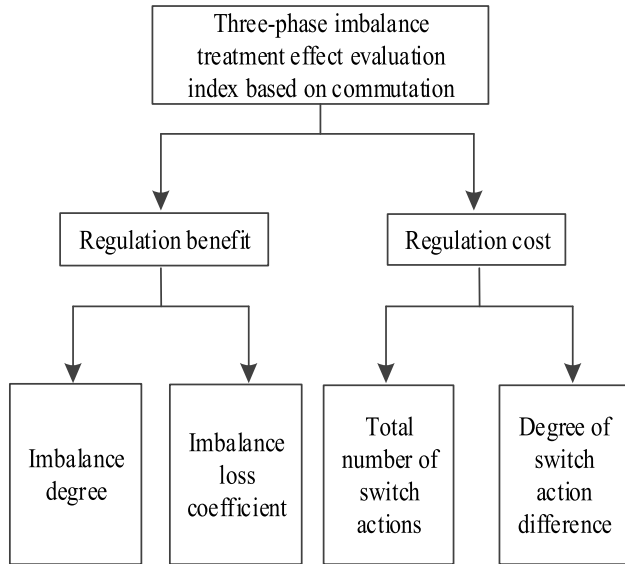

FIGURE 2. Index diagram of the three-phase imbalance treatment.

analyses to yield a subjective weighting method. The steps of using AHP to evaluate the effect of the three-phase imbalance treatment are as follows.

1) BUILD A JUDGMENT MATRIX

By collecting the opinions of a number of experts, according to the 1–9 ratio scaling theory, the pairwise judgment matrix is established for the indices at each level. The significance of the 1–9 ratio scaling is shown in Table 3. The intermediate state between the two scales, such as 2 and 4, indicates that the importance of the two indices is between the two scales.

2) PERFORM A JUDGMENT MATRIX CONSISTENCY CHECK

After the judgment matrix has been formed, the consistency check should be performed to calculate the consistency index C_I and the consistency ratio C_R . If $C_R < 0.1$, then the consistency of the judgment matrix is considered acceptable; if $C_R > 0.1$, then the judgment matrix should be revised until the consistency is acceptable. The formulas for calculating C_I and C_R are as follows.

$$C_I = (\lambda_{\max} - y)/(n - 1) \tag{3}$$

$$C_R = C_I/R_I \tag{4}$$

where λ_{\max} is the maximum eigenvalue of the judgment matrix and R_I is the average random consistency index.

3) DETERMINE THE SUBJECTIVE WEIGHT

After passing the consistency check, the maximum eigenvector of the judgment matrix is calculated and normalized, and then the total sorting is performed according to the level to obtain the subjective weight s_i of each index.

B. CALCULATION OF OBJECTIVE WEIGHT BASED ON IMPROVED ENTROPY WEIGHT METHOD

Information entropy is a measure of the uncertainty of a random event. The basic idea of the entropy weight method for determining the objective weight is as follows: according to the test data, the entropy value e_i of each index of the three-phase imbalance treatment is calculated and compared, and then the corresponding weight of each index is determined according to the entropy value. The specific steps are as follows.

1) ESTABLISH THE FUZZY JUDGMENT MATRIX

The treatment effect index set $V = \{v_1, v_2, \dots, v_n\}$ is a set composed of n indices to evaluate the treatment effect, and the evaluation set $Q = \{q_1, q_2, \dots, q_m\}$ is a set composed of m evaluation results of each evaluation index. Select excellent, fine, passed, poor, or very poor, corresponding to the 1st to 5th levels of the evaluation results, respectively. The evaluation function, f_{ij} , from index v_i to evaluation element q_j is established, and then the fuzzy evaluation matrix F from V to Q is obtained, which is expressed as follows.

$$F = \begin{bmatrix} f_{11} & f_{12} & \dots & f_{1m} \\ f_{21} & f_{22} & \dots & f_{2m} \\ \vdots & \vdots & \vdots & \vdots \\ f_{n1} & f_{n2} & \dots & f_{nm} \end{bmatrix} \tag{5}$$

2) CALCULATE THE ENTROPY VALUE

The entropy value of each index is calculated by the improved entropy weight method. First, for the judgment matrix, the entropy value, e_i , of the relative importance of a certain index, v_i , is calculated.

$$e_i = -\frac{1}{\ln m} \sum_{j=1}^m f_{ij} \ln f_{ij} \tag{6}$$

To prevent the variation of some index data from affecting the weight of the corresponding index, this paper uses activation function logistics to improve the traditional entropy weight method, and the improved entropy value is e'_i .

$$e'_i = \frac{1}{1 + e^{-e_i}} \tag{7}$$

3) CALCULATE THE OBJECTIVE WEIGHT

Calculate the objective weight, w_i , of each index using method shown in Formula (8).

$$w_i = \frac{1 - e'_i}{n - \sum_{i=1}^n e'_i} \tag{8}$$

C. DETERMINATION OF COMPREHENSIVE WEIGHTS

After the subjective weight and the objective weight have been calculated by Formula (9), the comprehensive weight, θ_i , of each index can be obtained.

$$\theta_i = \frac{s_i w_i}{\sum_{j=1}^n s_j w_j}, \quad i = 1, \dots, n \tag{9}$$

TABLE 2. Regulation cost index and its classification limit.

Evaluation indices		Three-phase imbalance treatment effect level				
First-level index	Second-level indices	Level 1	Level 2	Level 3	Level 4	Level 5
		Excellent	Fine	Average	Poor	Very poor
Regulation cost	Total number of switch actions	$\leq n_1$	$\leq n_2$	$\leq n_3$	$\leq n_4$	$\geq n_4$
	Degree of switch action difference	$\leq m_1$	$\leq m_2$	$\leq m_3$	$\leq m_4$	$\geq m_4$

TABLE 3. Judgment matrix formation criteria.

Scale value	Meaning
1	Both indices are equally important
3	The former is slightly more important than the latter
5	The former is obviously more important than the latter
7	The former is much more important than the latter
9	The former is extremely more important than the latter

IV. THREE-PHASE IMBALANCE TREATMENT EFFECT EVALUATION PROCESS

The evaluation process of the three-phase imbalance treatment effect using AHP and the improved entropy weight method is as follows.

Determine the evaluation time, T , classify the imbalance loss index and imbalance degree index according to expert opinions, and then determine the threshold value of each level of the switch action index according to the statistics of all switch action combinations under the load data of the specific test.

According to the test data, the time of the i -th index at the j -th level is calculated, which is represented by t_{ij} , and the probability distribution of the imbalance index at the j -th level is determined.

$$p_{ij} = \frac{t_{ij}}{T} \tag{10}$$

Count the total number of switch actions of the device under test within the statistical time T , calculate the degree of switch action difference, and determine the level of these two indices according to the threshold values given in step (1). If there is a corresponding level, $p_{ij} = 1$; otherwise, $p_{ij} = 0$

Form the fuzzy judgment matrix, F , in which the element $f_{ij} = p_{ij}$ represents the probability of the i -th index at the j -th level.

Calculate the subjective weight and the objective weight, obtain the comprehensive weight $\theta = [\theta_1, \theta_2, \dots, \theta_n]$ of each evaluation index, and then calculate the comprehensive

TABLE 4. Statistical time at all levels of benefit index.

Index	Statistical time/min for each level				
	Level 1	Level 2	Level 3	Level 4	Level 5
Imbalance loss coefficient	15	75	30	0	0
Imbalance degree	0	15	60	30	15

evaluation result R .

$$R = \theta \cdot F \tag{11}$$

Perform a weighted averaging on R to obtain the final evaluation result D .

$$D = \frac{\sum_{i=1}^n iR_i}{\sum_{i=1}^n R_i} \tag{12}$$

V. EXAMPLE ANALYSIS

According to the three-phase imbalance test method described in Section III, C, the load test data are given, the total time is 2 hours, the load changes every 15 minutes, and the level limit of each index is obtained according to the load data. The factor set V and the judgment set Q of the

TABLE 5. Evaluation results of each example.

Text example	Index	Statistical time/min for each level					Evaluation result
		Level 1	Level 2	Level 3	Level 4	Level 5	
Example 1	Imbalance loss coefficient	15	75	30	0	0	Between fine and passed (2.384)
	Imbalance degree	0	15	60	30	15	
	Total number of switch actions	0	1	0	0	0	
	Degree of switch action difference	0	0	1	0	0	
Example 2	Imbalance loss coefficient	45	75	0	0	0	Between excellent and fine (1.987)
	Imbalance degree	0	60	60	0	0	
	Total number of switch actions	0	1	0	0	0	
	Degree of switch action difference	0	0	1	0	0	
Example 3	Imbalance loss coefficient	90	30	0	0	0	Between excellent and fine (2.1861)
	Imbalance degree	60	60	0	0	0	
	Total number of switch actions	0	0	0	0	1	
	Degree of switch action difference	0	0	1	0	0	
Example 4	Imbalance loss coefficient	0	0	30	60	30	Between fine and passed (3.280)
	Imbalance degree	0	0	30	30	60	
	Total number of switch actions	1	0	0	0	0	
	Degree of switch action difference	0	0	1	0	0	
Example 5	Imbalance loss coefficient	45	75	0	0	0	Between fine and passed (2.479)
	Imbalance degree	0	60	60	0	0	
	Total number of switch actions	0	0	0	1	0	
	Degree of switch action difference	0	0	0	1	0	
Example 6	Imbalance loss coefficient	90	30	0	0	0	Between excellent and fine (1.993)
	Imbalance degree	60	60	0	0	0	
	Total number of switch actions	0	0	0	1	0	
	Degree of switch action difference	0	0	1	0	0	

treatment effect are determined. In the text, $V = \{\text{imbalance loss, imbalance degree, total number of switch actions, degree of switch action difference}\}$, $Q = \{\text{excellent, fine, passed, poor, very poor}\}$, corresponding to the five levels of treatment effect. The control result of a certain device is evaluated by the method combined with subjectivity and objectivity.

A. DETERMINE THE SUBJECTIVE WEIGHT BY USING AHP

According to the expert opinions, the judgment matrices R_1 and R_2 between the second-level indices of imbalance influence and switch action and the judgment matrix R between the two first-level indices are established.

$$R_1 = \begin{bmatrix} 1 & 3 \\ 1/3 & 1 \end{bmatrix} \quad R_2 = \begin{bmatrix} 1 & 2 \\ 1/2 & 1 \end{bmatrix} \quad R = \begin{bmatrix} 1 & 3 \\ 1/3 & 1 \end{bmatrix} \quad (13)$$

Explanation: For the influence of three-phase imbalance, the main consideration is the loss effect. After the loss effect is distinguished, the influence degree of imbalance is reduced, so the scale between the two indices is 3.

After the judgment matrix is formed, the consistency check should be carried out. Since the number of indices at all

levels in this paper is 2, there is no need to check. Finally, the subjective weights of each index are calculated as $s_1 = 0.5625$, $s_2 = 0.1875$, $s_3 = 0.1667$, and $s_4 = 0.0833$, which in turn represent the subjective weights of imbalance loss, imbalance degree, total number of switch actions, and degree of switch action difference.

B. FORM THE JUDGMENT MATRIX, F

According to the load data, the imbalance loss coefficient and the time when the imbalance degree is at different levels after the imbalance treatment of the tested intelligent terminal are counted. Table 4 is a set of statistical results.

The probability occupied by each level is calculated according to Formula (10), and together with the statistical value of the switch action index, a judgment matrix F is formed, as shown in Formula (14).

$$F = \begin{bmatrix} 0.125 & 0.625 & 0.250 & 0.000 & 0.000 \\ 0.000 & 0.125 & 0.500 & 0.250 & 0.125 \\ 0.000 & 1.000 & 0.000 & 0.000 & 0.000 \\ 0.000 & 0.000 & 1.000 & 0.000 & 0.000 \end{bmatrix} \quad (14)$$

C. CALCULATE THE OBJECTIVE WEIGHT BY USING THE IMPROVED ENTROPY WEIGHT METHOD

The entropy weight method is improved by Formulas (6) and (7), the matrix F is calculated, and the information value, e'_i , e_i of each index is 0.6363, 0.68, 0.5, and 0.5. Then, using Formula (8), the objective weights of each index are calculated as $w_1 = 0.2160$, $w_2 = 0.1901$, $w_3 = 0.2970$, and $w_4 = 0.2970$.

D. CALCULATE THE COMPREHENSIVE WEIGHT

By using Formula (9), the comprehensive weights of each index are calculated as $\theta_1 = 0.5251$, $\theta_2 = 0.1540$, $\theta_3 = 0.2139$, and $\theta_4 = 0.1069$.

E. CALCULATE THE COMPREHENSIVE EVALUATION RESULT VECTOR

The comprehensive evaluation result vector is calculated by using Formula (11).

$$\begin{aligned} R &= \theta \cdot F \\ &= [0.0656, 0.5614, 0.3152, 0.0385, 0.0193] \end{aligned}$$

F. OBTAIN THE FINAL EVALUATION RESULT

The results are judged by the weighted averaging method, and the final evaluation result, D , of the treatment effect is obtained. It is calculated that $D = 2.384$, which is between 2 and 3, indicating that the treatment effect is between fine and passed.

The evaluation results of several test statistics are shown in Table 5. Although the data in example 1 have a high degree of imbalance, its imbalance loss coefficient is low, which corresponds to the situation of a high imbalance degree and low loading rate, and fewer switch actions can achieve the effect of reducing loss. Therefore, the comprehensive evaluation result is between fine and passed. Comparing example 1 and example 2, if the same switch action level can reduce the imbalance degree and imbalance loss coefficient, then the comprehensive evaluation result is obviously better. Example 3 shows that although the imbalance degree and imbalance loss coefficient are low, switching too frequently also reduces the overall evaluation result. Example 4 reflects the situation in which the number of switch actions is small, both the imbalance degree and imbalance loss are high, and the comprehensive score is low. The comparison between example 5 and example 2 achieves the same imbalance degree and imbalance loss, the number of switching actions is high, and the difference is also determined. The final evaluation result is reduced from 1.987 to 2.479. Example 6 and example 3 are compared, due to the less number of switching actions, the difference is small, and the strategy is obviously better. The evaluation result is improved from 2.186 to 1.993, and the effect is better. The above examples reflect the mutual influence between regulation benefit and regulation cost and can provide a comprehensive evaluation of three-phase imbalance treatment based on commutation switch.

VI. CONCLUSION

This paper focuses on the three-phase imbalance treatment evaluation of intelligent terminals in the distribution area based on commutation switching and performs the following work:

The influence of the three-phase imbalance in the distribution area and the three-phase imbalance treatment principle based on the commutation switch are analyzed, the treatment effect and the influence introduced by the treatment process are combined, and the index system for the three-phase imbalance treatment of an intelligent terminal is proposed.

The weight of each evaluation index is determined by using AHP, and the improved entropy weight method is used to overcome the influence of some index data concentrations and determine the objective weight. The subjective weight and objective weight are combined to evaluate the three-phase imbalance treatment effect of the intelligent terminal.

The effectiveness of the evaluation method is verified by a set of examples. However, the algorithm still has some shortcomings, which cannot accurately distinguish the number of switch actions, and the evaluation results will be significantly different when its value is near the classification threshold value.

REFERENCES

- [1] D. Feng, Z. Chen, Z. Jiang, L. Yan, N. Qian, and X. Zong, "Analysis and treatment of three-phase unbalance problem," in *Proc. IEEE 4th Inf. Technol., Netw., Electron. Autom. Control Conf. (ITNEC)*, Jun. 2020, pp. 1501–1504.
- [2] K. Ma, L. R. Fang, and W. W. Kong, "Review of distribution network phase unbalance: Scale, causes, consequences, solutions, and future research directions," *CSEE J. Power Energy Systems.*, vol. 6, no. 3, pp. 479–488, Sep. 2020.
- [3] L. Wang, C.-S. Lam, and M.-C. Wong, "Unbalanced control strategy for a thyristor-controlled LC-coupling hybrid active power filter in three-phase three-wire systems," *IEEE Trans. Power Electron.*, vol. 32, no. 2, pp. 1056–1069, Feb. 2017.
- [4] A. Zhou, H. Zhai, M. Yang, and Y. Lin, "Three-phase unbalanced distribution network dynamic reconfiguration: A distributionally robust approach," *IEEE Trans. Smart Grid*, vol. 13, no. 3, pp. 2063–2074, May 2022.
- [5] X. Gao, Y. Wang, Z. Wang, and Z. Yang, "A method of solving three-phase power unbalance problem with PV inverters connected to the grid in series," in *Proc. 4th Int. Conf. Power Renew. Energy (ICPRE)*, Sep. 2019, pp. 249–253.
- [6] C. Yin, F. Wang, X. Ding, C. Tian, and P. Duan, "A novel compensator for three-phase load unbalance of the low voltage distribution network," in *Proc. Chin. Autom. Congr. (CAC)*, Oct. 2017, pp. 7518–7521.
- [7] Y. Yamamoto and T. Mannen, "Three-phase unbalance compensator using neutral point clamped multilevel interleaved inverter," in *Proc. IEEE 4th Southern Power Electron. Conf. (SPEC)*, Dec. 2018, pp. 1–7.
- [8] S. Liu, R. Jin, H. Qiu, X. Cui, Z. Lin, Z. Lian, Z. Lin, F. Wen, Y. Ding, Q. Wang, and L. Yang, "Practical method for mitigating three-phase unbalance based on data-driven user phase identification," *IEEE Trans. Power Syst.*, vol. 35, no. 2, pp. 1653–1656, Mar. 2020.
- [9] O. Pereira, J. Quiros-Tortos, and G. Valverde, "Phase rebalancing of distribution circuits dominated by single-phase loads," *IEEE Trans. Power Syst.*, vol. 36, no. 6, pp. 5333–5344, Nov. 2021.
- [10] P. Han, W. Pan, N. Zhang, H. Wu, R. Qiu, and Z. Zhang, "Optimization method for artificial phase sequence based on load forecasting and non-dominated sorting genetic algorithm," *Autom. Electr. Power Systems.*, vol. 44, no. 20, pp. 71–78, 2020.
- [11] J. Lv, W. Luan, R. Liu, P. Wang, and J. Lin, "Architecture of distribution Internet of Things based on widespread sensing & software defined technology," *Power Syst. Technol.*, vol. 42, no. 10, pp. 3108–3175, 2018.

- [12] Y. Sun, L. Wang, J. Xu, and G. Lin, "An intelligent coupling 3-grade fuzzy comprehensive evaluation approach with AHP for selection of levitation controller of maglev trains," *IEEE Access*, vol. 8, pp. 99509–99518, 2020.
- [13] Y. Huang, Y. Jiang, and J. Wang, "Adaptability evaluation of distributed power sources connected to distribution network," *IEEE Access*, vol. 9, pp. 42409–42423, 2021.
- [14] T. C. Huang, L. H. Ye, and Y. J. Zhang, "Comprehensive evaluation on electricity consumption reliability of power distribution network based on AHP-entropy weight method," *Guangdong Electr. Power*, vol. 31, no. 1, pp. 44–49, 2018.
- [15] M. Bajaj, A. K. Singh, M. Alowaidi, N. K. Sharma, S. K. Sharma, and S. Mishra, "Power quality assessment of distorted distribution networks incorporating renewable distributed generation systems based on the analytic hierarchy process," *IEEE Access*, vol. 8, pp. 145713–145737, 2020.
- [16] B. Zhang, S. Liu, H. Dong, S. Zheng, L. Zhao, R. Zhu, L. Zhao, Z. Lin, L. Yang, and Q. Wang, "Data-driven abnormality assessment for low-voltage power consumption and supplies based on CRITIC and improved radar chart algorithms," *IEEE Access*, vol. 8, pp. 27139–27151, 2020.
- [17] Z. Y. Cheng, W. W. Zhu, Q. Tao, M. Wang, and Z. Y. Hu, "Power quality evaluation method of distribution system based on improved radar chart," *Electr. Meas. Instrum.*, vol. 56, no. 14, pp. 34–39, 2019.

JIE CHEN was born in 1994. He received the master's degree. His research interests include distribution automation, distribution network digitization, and test technology of medium- and low-voltage electrical apparatuses.

FEIYAN ZHOU was born in 1995. She received the master's degree. Her research interests include the key technology for primary and secondary fusion of distribution networks, the key technology of distribution network fault simulation and testing, digital promotion, and the intelligent application technology of low-voltage power distribution equipment.

LINGYUN GU, photograph and biography not available at the time of publication.

HUI YIN, photograph and biography not available at the time of publication.

LI ZHANG, photograph and biography not available at the time of publication.

CHAOFEI GAO was born in Shijiazhuang, China, in 1986. He received the B.S., M.S., and Ph.D. degrees in electrical engineering from North China Electric Power University, in 2008, 2011, and 2019, respectively. He served as an Electrical Engineer at Shandong Power Supply Company, State Grid of China, from 2011 to 2015. He was a Visiting Scholar with the Center for Power Electronics Systems, Virginia Tech, from 2018 to 2019. He is currently an Associate Professor with Beijing Information Science and Technology University. His current research interest includes the condition monitoring of power apparatuses.

• • •