

Received 29 August 2022, accepted 16 September 2022, date of publication 22 September 2022, date of current version 30 September 2022.

Digital Object Identifier 10.1109/ACCESS.2022.3208704

RESEARCH ARTICLE

Hybrid Beamforming and Data Stream Allocation Algorithms for Power Minimization in Multi-User Massive MIMO-OFDM Systems

BO-YAN CHEN¹, YUNG-FANG CHEN², (Member, IEEE),
AND SHU-MING TSENG³, (Member, IEEE)

¹MediaTek Inc. (Headquarters), Hsinchu Science Park, Hsinchu 300, Taiwan

²Department of Communication Engineering, National Central University, Taoyuan 32001, Taiwan

³Department of Electronic Engineering, National Taipei University of Technology, Taipei 10608, Taiwan

Corresponding author: Yung-Fang Chen (yfchen@ce.ncu.edu.tw)

This work was supported in part by the Ministry of Science and Technology, Taiwan, under Grant MOST 111-2221-E-008-041 and Grant MOST 110-2221-E-008-038, and in part by the Qualcomm through the Taiwan University Research Collaboration Project.

ABSTRACT A hybrid beamforming structure is suggested as one of the solutions to reduce implementation costs and energy consumption in millimeter-wave massive multiple-input, multiple-output (MIMO) systems. In this study, an optimization problem of resource allocation was formulated to minimize the total system transmission power on downlink under a certain quality-of-service (QoS), such as bit/block error rates and data rates for each user, and the solution was proposed therein. Our proposed stream incremental algorithm can dynamically adjust the number of data streams for each user according to the channel state information. Precoding and combining schemes need to be developed to solve the formulated problem and also are proposed in this paper to be paired up with the stream incremental algorithm. Our proposed algorithms consider the practical modulation and coding scheme for transmission in various data stream allocation and beamforming designs. The proposed algorithms provide beamforming solutions for millimeter-wave massive MIMO systems, which achieve comparable performance to that of a fully digital block-diagonalization (BD) algorithm with a lower implementation cost and outperform those of modified existing hybrid beamforming algorithms. Simulation results demonstrate the efficacy of the proposed schemes by allocating the different numbers of data streams for each user according to the channel state information. The simulation results verified that the proposed method can achieve a good trade-off between complexity and performance on comparison with the modified existing schemes and the full digital solutions.

INDEX TERMS Millimeter-wave, massive MIMO, beamforming, hybrid beamforming, adaptive modulation and coding scheme, resource allocation.

I. INTRODUCTION

Millimeter-wave frequency communication is a promising candidate that can deal with the challenge of bandwidth shortage for the fifth generation (5G) and the beyond wireless cellular communication systems [1], [2]. Smaller cells are attractive for operation at millimeter-wave frequencies where the path loss is significantly high. Shorter wavelengths associated with higher frequencies are suitable for massive multiple-input, multiple-output (MIMO) designs because

of decreased antenna spacing and related electronics size. Therefore, massive MIMO can provide a large beamforming gain to compensate for the high path loss by using millimeter-wave frequency carriers [3]. A key challenge is that each antenna in a MIMO system generally requires a dedicated radio frequency (RF) chain [4]. Because of this, a hybrid beamforming structure has been suggested as one of the solutions to reduce the implementation cost and energy consumption. In the existing resource allocation related papers, most researches aim to maximize the total throughput subject to specific power constraints. At present, few reports consider the power control problems [5], [6], [7], [8]. However, in the

The associate editor coordinating the review of this manuscript and approving it for publication was Bilal Khawaja¹.

above papers, a single-carrier transmission method is used; the number of user antennas is one. Or, these papers develop hybrid beamforming algorithms but do not consider practical modulation or coding schemes to transmit data.

In recent years, more researchers have studied multi-user and multi-carrier scenarios. In existing research related to millimeter-wave massive MIMO systems, most of the papers mainly discuss single-carrier or single-user scenarios, but the practical millimeter-wave frequency band has a large amount of available bandwidth to support a large number of users, and orthogonal frequency-division multiplexing (OFDM) transmission may be considered. The number of antennas at the transmitter may be as high as hundreds, and the number of antennas at the receiver may also reach dozens. Due to the channel hardening, the subcarrier allocation task would no longer be required [9]. On the downlink, a scheduling method can be applied to all users in the cell, and the selected users can use the entire frequency band. However, extending the algorithm of a single-carrier scenario for the application to an OFDM system is not a simple task. The analog precoder is executed in the time domain and used for the entire bandwidth, while the digital precoder is executed on each sub-carrier basis. Therefore, the resulting multi-user broadband hybrid precoding problem becomes very complicated [10]. In view of the above discussion, we investigated multi-user and multi-carrier scenarios, adopted the multi-antenna hybrid architecture at the transceiver and the receiver, and considered the constraints of the data rates along with block error rates with practical modulation and coding schemes of each user to minimize the transmission power.

The characteristics of the millimeter-wave channel were studied because the channel characteristics are quite different from the traditional microwave frequency band [1], [11], [12], [13], [14]. Then, scholars considered the single-carrier and point-to-point systems [15], [16], [17], [18], [19], [20] for simulation and implementation. After some basic properties were studied, researchers considered the scenarios of either a single-carrier and multi-user [21], [22], [23], [24], [25] or multi-carrier and single-user systems [26], [27], [28]. In recent years, more researchers have studied multi-user and multi-carrier systems [29], [30], [31], [32]. For OFDM-based systems, the effect of inter-user interference and to design a digital beamformer must be considered on a per sub-carrier basis, respectively. In hybrid beamforming designs, several design criteria can be adopted. One approach may include matrix factorization imposed by the phase shifters restriction [33]. Another approach is to decompose the design of the analog beamformer and the digital beamformer into two stages. The analog beamformer harvests array gain, and the digital beamformer is responsible for eliminating interference [34], [35]. In the analog beamformer design, a low complexity approach is followed through codebook selection [36]. In one report [34], the authors used the equal gain transmission method to design the analog beamformer, which leads to some limitations and cannot be used in the scenario of data stream adjustment. Particularly, the authors

in [32] study the single-carrier scenario and use the interference plus noise suppression criteria to design the digital beamformer; the authors in previous reports [37], [38], [39] considered multi-carrier scenarios; these three papers use the criteria of maximizing the signal-to-leakage-plus-noise ratio, weighted sum mean square error minimization, and minimizing mean square error (MMSE) to design the digital beamformer, respectively. These papers mentioned above do not guarantee that all interferences are eliminated to satisfy the constraints of bit error rates and block error rates (BERs/BLERs). In addition, although researchers considered multi-carrier and multi-user scenarios [40] and [41], their user equipment was set to a single antenna, so their methods are not feasible to use in our scenario. In [5], [6], [7], and [8], the authors considered the power control problems for a narrow-band single antenna millimeter-wave massive MIMO system. We investigated multi-carrier and multi-antenna millimeter-wave massive MIMO systems where data rates, block error rates, practical modulation, and coding schemes of each user are considered. Based on the above discussion, the methods of these papers could not be applied directly to solve the optimization problem of this study and to be compared with the proposed schemes. To the best of our knowledge, the scenario setting along with the problem formulation has not been investigated so far.

In this paper, we investigated a resource allocation problem for multi-carrier (OFDM) and multi-user millimeter-wave systems and use a multi-antenna hybrid architecture at the transceiver to design the beamforming algorithm to pair with the resource allocation solution for the formulated problem. The main contributions are summarized as follows.

- Common optimization problems in this field include either capacity problems – maximizing the total throughput subject to specific power constraints, or power control problems – minimizing the transmission power under a certain quality-of-service (QoS) for each user. In the millimeter-wave large antenna array systems under consideration, most papers discuss the capacity problems. Up to now, only a few studies have investigated the above power control problems. However, in these few studies, a single-carrier transmission method was used; the number of user antennas was one, and the required received SINR of each user was not considered to meet the error rate and data rate constraints. We studied the power control problems for multi-user and multi-carrier and adopted the multi-antenna hybrid architecture at the transceiver. The constraints of the data rates along with block error rates with practical modulation, and coding schemes of each user were considered to minimize the transmission power. To the best of our knowledge, the resource allocation problem along with the beamforming design with the above scenario has not been considered yet in the literature.
- The existing studies assumed that each user transmits the same number of data streams. If power control regarding

resource allocation is the main purpose, it may be more advantageous to offer flexible assignments regarding the number of data streams for users. This novel idea motivated us to design a resource allocation algorithm with the number of data streams adjustment to achieve better performance in terms of transmit power. Therefore, we proposed a data stream allocation algorithm based on an equivalent bit incremental loading idea for practical modulation and coding scheme (MCS such as in 3gpp) selection.

- A hybrid beamforming algorithm can be designed based on various viewpoints. One of the approaches is to find a fully digital beamforming solution first and try to minimize the Euclidean distance between the fully digital beamforming solution and the hybrid beamforming solution. In one report [42], the authors imposed a semi-orthogonal constraint on the digital beamformer and propose an alternating minimization (AltMin) algorithm. The structure of the analog beamformer was adjusted to be the single phase-shifter. Then, the scheme was modified in the received digital combiner so that the inter-stream interference can be eliminated. After the modification and the re-derivation, due to the interference cancelation capability, this beamforming scheme can be applied to solve the formulated optimization problem in this paper to satisfy the constraint of BERs/BLERs by using the practical MCS such as in 3gpp.
- The performance of the traditional classic block-diagonalization (BD) method is affected by the number of transmitting and receiving antennas due to the limitation on the serving number of users by the base station at the same time owing to the interference effect. Therefore, compared with this method, our proposed algorithm has better flexibility in the number of serving users. In our proposed processing scheme, a parameter can be adjusted to reduce computational complexity. Simulation results also verify that the proposed algorithms can achieve a good trade-off between complexity and performance compared with these existing schemes.

The following notations are used throughout this paper. The lower-case boldface letter \mathbf{a} and upper-case boldface letter \mathbf{A} stand for a column vector and a matrix, respectively; The conjugate, transpose, and conjugate transpose of \mathbf{A} are represented by \mathbf{A}^* , \mathbf{A}^T , and \mathbf{A}^H ; $\max(\mathbf{A})$ and $\min(\mathbf{A})$ indicate the maximum and the minimum values of \mathbf{A} , respectively; $|a|$ is the amplitude of scalar a ; $\|\mathbf{a}\|$ denote the Euclidean norm of \mathbf{a} , and $\|\mathbf{A}\|_F$ denote the Frobenius norm of \mathbf{A} ; $\text{rank}(\mathbf{A})$ and $\text{Tr}(\mathbf{A})$ indicate the rank and trace of \mathbf{A} , respectively; $\mathbf{A}(i, j)$ represent the element in the i -th row and j -th column of \mathbf{A} . The phase of a complex variable is noted by $\angle[\cdot]$; $\text{Card}(A)$ denotes the cardinality of set A ; $\mathcal{O}(\cdot)$ is the big O notation for complexity analysis.

The remainder of this paper is organized as follows. In Section II, we introduce the adopted hybrid beamforming,

channel model and the problem formulation. In Section III, the two beamforming algorithms are compared, and we proposed a beamforming algorithm as the main contribution to solve the formulated optimization problem. These include the modified phase extraction alternating minimization (PE-AltMin) hybrid precoding/combining, the multi-carrier extension of the fully digital block diagonalization precoding/combining, and the proposed two-stage hybrid precoding/combining. In addition, we also discuss the proposed stream incremental algorithm based on the MCS index allocation/equivalent bit incremental loading algorithm. In Section IV, the computational complexity for the proposed hybrid precoding/combining schemes are analyzed. Simulation results are presented in Section V. Finally, Section VI presents the conclusion of this paper.

II. SYSTEM MODEL

A. HYBRID PRECODING AND COMBINING STRUCTURE

A downlink multi-user millimeter-wave MIMO-OFDM system as shown in Fig. 1., was considered. A base station equipped with N_t antennas and N_{rRF} RF chains simultaneously transmits N_s data streams to serve selected users over K subcarriers using OFDM. And each user equipment is equipped with N_r antennas and N_{rRF} RF chains to receive $n_{s,u}$ data streams, where $n_{s,u}$ is the number of received data streams by the u -th user. The transmitted data streams are allocated to all U users, and the number is $n_{s,1} + n_{s,2} + \dots + n_{s,U} = N_s$. The existing papers assumed that each user transmits the same number of data streams $n_{s,1} = n_{s,2} = \dots = n_{s,U}$. However, allocating different numbers of data streams according to the channel state information of each user may further improve the performance. Therefore, we assumed that the number of data streams allocated to each user would be different. $N_s \leq N_{rRF} < N_t$ and $n_{s,u} \leq N_{rRF} < N_r$ should be satisfied to hold the multiplexing of data streams.

In the hybrid beamforming structure, input data symbols are precoded by a low-dimension digital precoder $\mathbf{F}_{BB}[k] \in \mathbb{C}^{N_{rRF} \times N_s}$, $k = 1, \dots, K$. After digital precoding $\mathbf{F}_{BB}[k]$, signals are transformed from the frequency domain to the time domain by $N_{rRF}K$ -points inverse fast Fourier transforms (IFFTs) and added cyclic prefixes (CP).

Next, an analog precoder $\mathbf{F}_{RF} \in \mathbb{C}^{N_t \times N_{rRF}}$ was adopted to generate the final transmitted signal. The analog precoder \mathbf{F}_{RF} was executed in the time domain and used for the entire bandwidth, while the digital precoder was executed on each subcarrier basis, thus, complicating the resulting broadband hybrid precoding design problem [10].

The final transmitted signal for the u -th user on the k -th subcarrier is written as

$$\mathbf{x}_u[k] = \mathbf{F}_{RF}\mathbf{F}_{BBu}[k]\mathbf{s}_u[k] \quad (1)$$

where $\mathbf{F}_{BB}[k] = [\mathbf{F}_{BB1}[k], \mathbf{F}_{BB2}[k], \dots, \mathbf{F}_{BBU}[k]] \in \mathbb{C}^{N_{rRF} \times N_s}$, $\mathbf{s}[k] = [\mathbf{s}_1^T[k], \mathbf{s}_2^T[k], \dots, \mathbf{s}_U^T[k]]^T \in \mathbb{C}^{N_s \times 1}$ is the transmit modulated data symbols on the k -th subcarrier with $\mathbb{E}[\mathbf{s}[k]\mathbf{s}^H[k]] = \frac{P}{KN_s}\mathbf{I}_{N_s}$, and P is the transmit power.

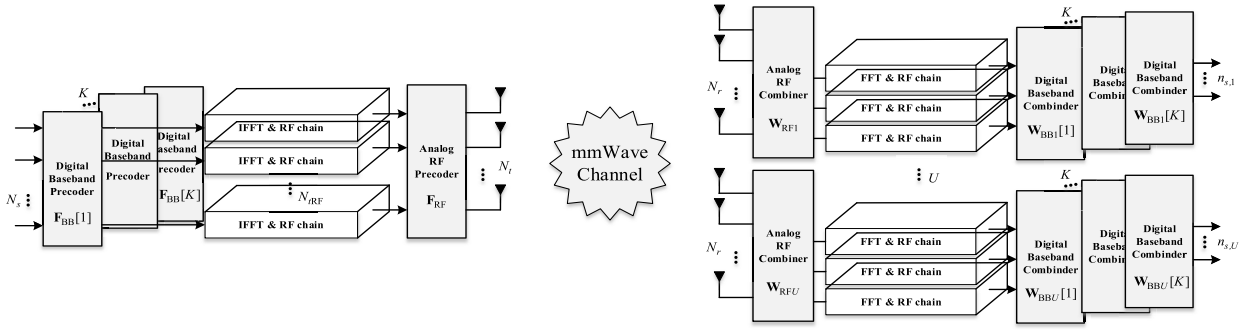

FIGURE 1. Illustration of the downlink multi-user millimeter wave MIMO-OFDM system in which the BS and the UEs both employ the hybrid beamforming architecture.

Assuming a block fading channel model and perfect carrier frequency offset synchronization, the received signal over a MIMO channel for the u -th user on the k -th subcarrier is

$$\mathbf{y}_u[k] = \mathbf{H}_u[k] \sum_{j=1}^U \mathbf{x}_j[k] + \mathbf{z}_u[k] \quad (2)$$

where $\mathbf{H}_u[k] \in \mathbb{C}^{N_r \times N_t}$ is the frequency domain channel for the u -th user on the k -th subcarrier, and $\mathbf{z}_u[k] \sim \mathcal{CN}(0, \sigma_n^2)$ is the circularly symmetric additive white Gaussian noise with power σ_n^2 for the u -th user on the k -th subcarrier.

At the receiver, the received signals were first combined by the common analog combiner $\mathbf{W}_{RFu} \in \mathbb{C}^{N_r \times N_{rRF}}$. Then, it removed CP and transformed the signals from the time domain to the frequency domain by $N_{rRF}K$ -points FFT. Finally, a low-dimension digital combiner $\mathbf{W}_{BBu}[k] \in \mathbb{C}^{N_{rRF} \times n_{s,u}}$ was employed for each subcarrier. Then, the final received signals for the u -th user on the k -th subcarrier was

$$\begin{aligned} \tilde{\mathbf{y}}_u[k] &= \mathbf{W}_{BBu}^H[k] \mathbf{W}_{RFu}^H \mathbf{H}_u[k] \sum_{j=1}^U \mathbf{F}_{RF} \mathbf{F}_{BBj}[k] \mathbf{s}_j[k] \\ &+ \mathbf{W}_{BBu}^H[k] \mathbf{W}_{RFu}^H \mathbf{z}_u[k]. \end{aligned} \quad (3)$$

Particularly, the analog precoder \mathbf{F}_{RF} and the analog combiner \mathbf{W}_{RFu} , $u = 1, \dots, U$ were implemented by phase-shifters. We adopted the most common fully connected and single phase-shifter architecture [32] in this paper.

The millimeter-wave propagation can be well characterized by a cluster Saleh-Valenzuela channel model for millimeter-wave systems [43]. The time-domain channel tap between the base station and the u -th user can be modeled as

$$\mathbf{H}'_u[d] = \sum_{l=0}^{N_{cl}-1} \mathbf{H}_{u,l} \delta[d-l] \quad (4)$$

where N_{cl} is the number of scattering clusters, $\delta[\cdot]$ is the Kronecker delta function, and the l -th tap for the u -th user can be modeled as the sum of N_{ray} contributions of propagation paths in a cluster, given by

$$\mathbf{H}_{u,l} = \frac{1}{\sqrt{p_{l,u}}} \sum_{i=1}^{N_{ray}} \alpha_{i,l} \mathbf{a}_r(\phi_{i,l}^r) \mathbf{a}_t^H(\phi_{i,l}^t) \quad (5)$$

where $\alpha_{i,l} \sim \mathcal{CN}(0, N_t N_r P_l / N_{ray})$ is the complex gain for the i -th propagation path in the l -th cluster; $p_{l,u}$ is the path loss for the u -th user; $\phi_{i,l}^r$ and $\phi_{i,l}^t$ are the angles of arrival and departure for the i -th propagation path in the l -th cluster, respectively.

Further, $\mathbf{a}_r(\cdot)$ and $\mathbf{a}_t(\cdot)$ are the antenna array response vectors for the receiver and the transmitter, respectively. We considered the scenario of N_{cl} clusters and N_{ray} scatterers per cluster [44] in which the angles of arrival (departure) are generated by following the Laplacian distribution with random mean cluster angles $\bar{\phi}_{cl}^r \in [0, 2\pi]$ ($\bar{\phi}_{cl}^t \in [0, 2\pi]$) and angular spreads of θ_{as} within each cluster. This paper adopted the uniform linear array configuration with N antennas and antenna spacing d . Therefore, the antenna array response vector was expressed as

$$\mathbf{a}(\phi) = \sqrt{\frac{1}{N}} \left[1, e^{j\frac{2\pi}{\lambda} d \sin(\phi)}, \dots, e^{j(N-1)\frac{2\pi}{\lambda} d \sin(\phi)} \right]^T \quad (6)$$

where λ is the signal wavelength and d is usually set to $\frac{\lambda}{2}$.

By applying the fast Fourier transform (FFT) to the time domain channel, the frequency domain channel coefficient between the base station and the u -th user on the k -th subcarrier can be expressed as

$$\mathbf{H}_u[k] = \sum_{l=0}^{N_{cl}-1} \mathbf{H}_{u,l} e^{-j2\pi l(k/K)}, \quad k = 0, 1, \dots, K-1. \quad (7)$$

B. PROBLEM FORMULATION

As the motivation described in Section I, the scenario under consideration is multi-user and multi-carrier, and we adopted the multi-antenna hybrid architecture at the transceiver. We considered the data rate, the block error rate, and the practical modulation and coding scheme of each user to minimize the transmission power. Based on our observations and due to the channel hardening, subcarrier allocation would be no longer required [9]. With OFDM transmission, each subcarrier in a massive MIMO system has a property of similar channel gains after beamforming. Therefore, the entire bandwidth would be employed for each user. We assumed that the

receiver can perfectly obtain the channel state information. The optimization problem was formulated as

$$\underset{\substack{\mathbf{W}_{RFu}^U, [\mathbf{W}_{BBu}[k]]_{k=1}^K]_{u=1}^U, \\ \mathbf{F}_{RF}, [\mathbf{F}_{BB}[k]]_{k=1}^K, (n_{su})_{u=1}^U}}{\text{minimize}} \sum_{u=1}^U \sum_{k=1}^K \sum_{n=1}^{n_{s,u}} P(r_{u,n,k}) \quad (8a)$$

$$\text{subject to } |\mathbf{F}_{RF}(i, j)| = 1, \quad \text{and } |\mathbf{W}_{RFu}(i, j)| = 1 \quad (8b)$$

$$\sum_{k=1}^K \sum_{n=1}^{n_{s,u}} r_{u,n,k} \geq R, \quad \text{for } u = 1, \dots, U. \quad (8c)$$

Assume $f_k(r_{u,n,k})$ is the required receive SINR for a particular BLER such as 10^{-1} . (8d)

Then, the required transmission power for the n -th data stream on the k -th subcarrier for the u -th user can be expressed as

$$P(r_{u,n,k}) = \frac{f_k(r_{u,n,k}) \left\| \mathbf{w}_{BBu,n}^H[k] \mathbf{W}_{RFu}^H \right\|^2 \sigma_n^2}{\left\| \mathbf{w}_{BBu,n}^H[k] \mathbf{W}_{RFu}^H \mathbf{H}_u[k] \mathbf{F}_{RF} \mathbf{f}_{BBu,n}[k] \right\|^2}. \quad (9)$$

The beamforming weight vectors for the u -th user on the k -th subcarrier are denoted as

$$\begin{aligned} \mathbf{W}_{BBu}[k] &= [\mathbf{w}_{BBu,1}[k], \dots, \mathbf{w}_{BBu,n_{s,u}}[k]]; \\ \mathbf{F}_{BBu}[k] &= [\mathbf{f}_{BBu,1}[k], \dots, \mathbf{f}_{BBu,n_{s,u}}[k]] \end{aligned} \quad (10)$$

where $\mathbf{w}_{BBu,n}[k]$ is the n -th column of $\mathbf{W}_{BBu}[k]$, and $\mathbf{f}_{BBu,n}[k]$ is the n -th column of $\mathbf{F}_{BBu}[k]$.

Based on (8a), we planned to design the hybrid beamforming weight vectors and allocate the appropriate number of data streams for each user to minimize the transmission power of the base station. (8b) indicates the hardware limitation due to fully connected and single phase-shifter architecture. And (8c) means that each user must reach a minimum predetermined data rate constraint R , where $r_{u,n,k} \in B$, and B is the set of available equivalent loading bits defined in Table 1 as described later.

III. PROPOSED HYBRID BEAMFORMING SCHEMES

The main challenge in this multi-user spectrum sharing system was to design the beamformer while considering the inter-user interference cancellation. In this section, we adapted two beamforming algorithms for performance comparison and propose beamforming processing schemes as the main contribution to solve the optimization problem. These first two beamforming algorithms in the following discussions were used as performance benchmarks to be compared with the proposed methods described in this Subsection C. After developing these three beamforming algorithms, the proposed MCS index allocation algorithm was derived to satisfy the remaining optimization problem constraints. We will also develop the proposed stream incremental algorithm to achieve better system performance.

A. MODIFIED PE-ALTMIN HYBRID BEAMFORMING

The authors in an earlier report [33] developed an alternating minimization (AltMin) algorithm mainly in a single-user system. If this scheme were extended to multi-user and multi-carrier systems for solving the formulated optimization problem along with the constraints in this paper, adaptation would be required for the application. Due to the use of MCS index selection to satisfy BERS/BLERs, it is required to ensure that the interference effect is eliminated. A cascade digital combiner is adopted to achieve this purpose. Therefore, a cascade of additional block-diagonalization (BD) precoders based on the effective channel idea to cancel the residual interference was used [42]. For a multi-carrier system design, we arranged precoders, where $\mathbf{F}_{\text{dig}} = [\mathbf{F}_{\text{dig}}[1], \mathbf{F}_{\text{dig}}[2], \dots, \mathbf{F}_{\text{dig}}[K]]$ is the $N_t \times KN_s$ combined fully digital precoder, for all subcarriers into a larger matrix and then deal with the optimization problem. After designing the hybrid beamformer through the steps, we defined an effective channel for the u -th user on the k -th subcarrier as

$$\hat{\mathbf{H}}_u[k] = \mathbf{W}_{BBu}^H[k] \mathbf{W}_{RFu}^H \mathbf{H}_u[k] \mathbf{F}_{RF} \mathbf{F}_{BB}[k] \quad (11)$$

where $\mathbf{W}_{BBu}[k]$ is the $N_{rRF} \times n_{s,u}$ digital combiner for the u -th user on the k -th subcarrier, \mathbf{W}_{RFu} is the $N_r \times N_{rRF}$ analog combiner for the u -th user, $\mathbf{H}_u[k]$ is the frequency domain channel for the u -th user on the k -th subcarrier, \mathbf{F}_{RF} is the $N_t \times N_{tRF}$ common analog precoder, and $\mathbf{F}_{BB}[k]$ is the $N_{tRF} \times N_s$ combined digital precoder on the k -th subcarrier.

After some derivations, the effective channel $\hat{\mathbf{H}}_u[k]$ is the input of the block-diagonalization (BD) algorithm to obtain $\mathbf{F}_{BD}[k]$ and $\mathbf{W}_{BDu}[k]$ for the cascade digital combiner; it was thus achieved so that the inter-stream interference was eliminated to solve the optimization problem for the comparison in this paper. The processing steps are illustrated by the pseudo-code in *Algorithm 1*, labeled Modified PE-AltMin Algorithm. Although this method has a low complexity, its performance depends on the initial input of the fully digital solutions.

B. FULLY DIGITAL BLOCK DIAGONALIZATION BEAMFORMING

The fully digital block-diagonalization (BD) algorithm was proposed earlier [45] for a single-carrier scenario. For a multi-carrier system, the following constraint was imposed herein, on each subcarrier to eliminate inter-user interference.

$$\mathbf{H}_i[k] \mathbf{F}_j[k] = \mathbf{0} \quad \text{for } i \neq j \quad (12)$$

where $\mathbf{H}_i[k]$ is the frequency domain channel for the i -th user on the k -th subcarrier, and $\mathbf{F}_j[k]$ is the digital precoder for the j -th user on the k -th subcarrier. The processing scheme is illustrated by the pseudo-code in *Algorithm 2* labeled Fully Digital BD Algorithm. This scheme is aimed for the comparison with the following proposed hybrid beamforming.

C. PROPOSED HYBRID BEAMFORMING

The above fully digital BD method can achieve good performance in the traditional rich scattering Rayleigh fading chan-

Algorithm 1 Steps by Using PE-AltMin Algorithm

Inputs: $\mathbf{F}_{\text{dig}}, \mathbf{H}[k] = [\mathbf{H}_1^T[k], \dots, \mathbf{H}_U^T[k]]^T, k = 1, \dots, K$.

- 1: Construct $\mathbf{F}_{\text{RF}}^{(0)}$ with a feasible phase and set $i = 0$.
- 2: **repeat**
- 3: Fix $\mathbf{F}_{\text{RF}}^{(i)}$, compute the SVD of $\mathbf{F}_{\text{dig}}^H \mathbf{F}_{\text{RF}}^{(i)} = \mathbf{U}_1^{(i)} \mathbf{S}^{(i)} \mathbf{V}^{(i)H}$.
- 4: Update $\mathbf{F}_{\text{BB}}^{(i)} = \mathbf{V}^{(i)} \mathbf{U}_1^{(i)H}$.
- 5: Fix $\mathbf{F}_{\text{BB}}^{(i)}$, and update $\mathbf{F}_{\text{RF}}^{(i)}$ by $\mathbf{F}_{\text{RF}} = e^{j\angle \mathbf{F}_{\text{dig}} \mathbf{F}_{\text{BB}}^H}$.
- 6: $i \leftarrow i + 1$.
- 7: **until** a stopping criterion triggers.
- 8: Construct the effective channel.
- 9: According to the effective channels, calculate the BD precoders $\tilde{\mathbf{F}}_{\text{BD}}[k]$ and combiner $\mathbf{W}_{\text{BD}u}[k]$.
- 10: Calculate $\tilde{\mathbf{F}}_{\text{BB}}[k] = \mathbf{F}_{\text{BB}}[k] \tilde{\mathbf{F}}_{\text{BD}}[k]$.
- 11: Calculate $\mathbf{W}_{\text{BB}u}[k] = \mathbf{W}_{\text{BB}u}[k] \mathbf{W}_{\text{BD}u}[k]$.
- 12: For digital precoder at the transmitter, normalize $\mathbf{F}_{\text{BB}}[k] = \frac{\sqrt{N_s}}{\|\mathbf{F}_{\text{RF}} \tilde{\mathbf{F}}_{\text{BB}}[k]\|_F} \tilde{\mathbf{F}}_{\text{BB}}[k]$.

Outputs: $\mathbf{F}_{\text{RF}}, \mathbf{W}_{\text{RF}}$ and $\mathbf{W}_{\text{BB}}[k], \mathbf{F}_{\text{BB}}[k], k = 1, \dots, K$.

Algorithm 2 Steps by Using Fully Digital BD Algorithm

Inputs: $n_{s,u}, u = 1, \dots, U$.

$$\mathbf{H}[k] = [\mathbf{H}_1^T[k], \mathbf{H}_2^T[k], \dots, \mathbf{H}_U^T[k]]^T, k = 1, \dots, K.$$

- 1: **for** every k -th subcarrier **do**
- 2: **for** every u -th user **do**
- 3: Calculate the null space of the interference channel.
- 4: Calculate SVD of the effective channel.
- 5: Calculate $\mathbf{F}_u[k] = \tilde{\mathbf{V}}_{u2}[k] \mathbf{V}_{u1}[k]$.
- 6: Calculate $\mathbf{W}_u[k] = \mathbf{U}_{u1}[k]$.
- 7: **end**
- 8: **end**

Outputs: Obtain digital precoder and digital combiner

$$\begin{aligned} \mathbf{F}_{\text{dig}}[k] &= [\mathbf{F}_1[k], \dots, \mathbf{F}_U[k]], k = 1, \dots, K. \\ \mathbf{W}_{\text{dig}}[k] &= [\mathbf{W}_1[k], \dots, \mathbf{W}_U[k]], \\ &k = 1, \dots, K. \end{aligned}$$

nel and the millimeter-wave channel with limited scattering. But the condition of $N_t \geq UN_r$ had to be satisfied to find the null space of interference for each user. This condition led to a limitation on the number of users served by the base station simultaneously. The fully digital BD algorithm can achieve sub-optimal performance in a multi-user MIMO system [34]. In the millimeter-wave scenario with limited scattering, the performance of the hybrid beamforming algorithm may be better than that of the fully digital BD algorithm. Due to the limited number of clusters, the frequency selective fading effect is not obvious. Therefore, it is more likely that an analog beamformer appropriately shared by all sub-carriers is designed. These observations motivate us to design a hybrid beamforming algorithm along with the capability of flexibly,

adjusting the number of data streams to achieve better performance.

In a single-carrier scenario, the analog precoder design and analog combiner design may be viewed as two independent stages [34], [43]. It assumes that the analog precoder is an optimal para-unitary matrix on a per subcarrier basis [37]. Then the analog combiner is designed to have the largest array gain for each user regardless of the inter-user interference. The optimal analog combiner for the u -th user can be expressed as

$$\begin{aligned} \mathbf{W}_{\text{RF}u}^{\text{opt}} &= \arg \max_{\mathbf{W}_{\text{RF}u}} \frac{1}{K} \left\| \mathbf{W}_{\text{RF}u}^H \mathbf{H}_u^{(h)} \right\|_F^2 \\ \text{s.t. } &|\mathbf{W}_{\text{RF}u}(i, j)| = 1 \end{aligned} \quad (13)$$

where $\mathbf{H}_u^{(h)} = [\mathbf{H}_u[1], \mathbf{H}_u[2], \dots, \mathbf{H}_u[K]]$ is the $N_r \times (N_t K)$ horizontal tensor unfolding of the three-dimensional matrix. SVD is performed on $\mathbf{H}_u^{(h)}$ to have $\mathbf{H}_u^{(h)} = \tilde{\mathbf{U}}_u \tilde{\Sigma}_u \tilde{\mathbf{V}}_u^H$, where $\tilde{\mathbf{U}}_u$ and $\tilde{\mathbf{V}}_u$ are the left and right singular matrices, respectively; $\tilde{\Sigma}_u$ is the non-negative diagonal matrix constituted by the singular values of $\mathbf{H}_u^{(h)}$. By expanding the term in the norm, the objective function of (13) can be expressed as

$$\begin{aligned} &\left\| \mathbf{W}_{\text{RF}u}^H \mathbf{H}_u^{(h)} \right\|_F^2 \\ &= \text{Tr} \left\{ \left(\mathbf{W}_{\text{RF}u}^H \tilde{\mathbf{U}}_u \tilde{\Sigma}_u \tilde{\mathbf{V}}_u^H \right)^H \left(\mathbf{W}_{\text{RF}u}^H \tilde{\mathbf{U}}_u \tilde{\Sigma}_u \tilde{\mathbf{V}}_u^H \right) \right\} \\ &= \text{Tr} \left\{ \tilde{\mathbf{V}}_u \tilde{\Sigma}_u^H \tilde{\mathbf{U}}_u^H \mathbf{W}_{\text{RF}u}^H \mathbf{W}_{\text{RF}u} \tilde{\mathbf{U}}_u \tilde{\Sigma}_u \tilde{\mathbf{V}}_u^H \right\} \\ &= \text{Tr} \left\{ \tilde{\Sigma}_u^2 \tilde{\mathbf{U}}_u^H \mathbf{W}_{\text{RF}u}^H \mathbf{W}_{\text{RF}u} \tilde{\mathbf{U}}_u \right\} \end{aligned} \quad (14)$$

Next, we can partition these two matrices $\tilde{\Sigma}_u$ and $\tilde{\mathbf{U}}_u$ as

$$\tilde{\Sigma}_u = \begin{bmatrix} \tilde{\Sigma}_{u1} & \mathbf{0} \\ \mathbf{0} & \tilde{\Sigma}_{u2} \end{bmatrix}, \quad \tilde{\mathbf{U}}_u = [\tilde{\mathbf{U}}_{u1} \quad \tilde{\mathbf{U}}_{u2}] \quad (15)$$

where $\tilde{\Sigma}_{u1}$ is the $N_{r\text{RF}} \times N_{r\text{RF}}$ diagonal matrix, and $\tilde{\mathbf{U}}_{u1}$ is the first $N_{r\text{RF}}$ columns of the matrix $\tilde{\mathbf{U}}_u$. It implies that to maximize this function is to set $\mathbf{W}_{\text{RF}u} = \tilde{\mathbf{U}}_{u1}$. By Euclidean projection of $\tilde{\mathbf{U}}_{u1}$ onto the feasible set to satisfy the constant modulus norm constraints, we obtained the expression for the solution as

$$\mathbf{W}_{\text{RF}u}^{\text{opt}} = e^{j\angle \tilde{\mathbf{U}}_{u1}}. \quad (16)$$

After the analog combiners are designed, we regard the result of the multiplication of the analog combiner and the frequency domain channel as an equivalent channel. Then the analog precoder $\mathbf{F}_{\text{RF}} = [\mathbf{F}_{\text{RF}1}, \mathbf{F}_{\text{RF}2}, \dots, \mathbf{F}_{\text{RF}U}]$ is designed to have the largest array gain regardless of the inter-user interference. The derivation process is similar to that of above the analog combiner such that the analog precoder for the u -th user $\mathbf{F}_{\text{RF}u}$ is the first $n_{s,u}$ columns of the matrix $\tilde{\mathbf{V}}_u$ expressed as $\tilde{\mathbf{V}}_{u1}$. Then, the phases are fetched to satisfy the constant modulus norm constraints. The entire process of the analog beamformer design is shown by the pseudo-code in **Algorithm 3-1** denoted as Proposed Hybrid Beamforming Algorithm (Analog).

Algorithm 3-1 Proposed Hybrid Beamforming Algorithm (Analog)

Inputs: $n_{s,u}, u = 1, \dots, U$.

$$\mathbf{H}[k] = [\mathbf{H}_1^T[k], \mathbf{H}_2^T[k], \dots, \mathbf{H}_U^T[k]]^T, k = 1, \dots, K.$$

- 1: **for** every u -th user **do**
- 2: $\mathbf{H}_u^{(h)} = [\mathbf{H}_u[1], \mathbf{H}_u[2], \dots, \mathbf{H}_u[K]]$.
- 3: Calculate SVD of $\mathbf{H}_u^{(h)} = \tilde{\mathbf{U}}_u \tilde{\Sigma}_u \tilde{\mathbf{V}}_u^H$.
- 4: Calculate $\mathbf{W}_{RFu} = e^{j\angle \tilde{\mathbf{U}}_{u1}}$.
- 5: $\mathbf{H}_{\text{eff}u}^{(l)} = [(\mathbf{W}_{RFu}^H \mathbf{H}_u[1])^T, \dots, (\mathbf{W}_{RFu}^H \mathbf{H}_u[K])^T]^T$.
- 6: Calculate SVD of $\mathbf{H}_{\text{eff}u}^{(l)} = \tilde{\mathbf{U}}_u \tilde{\Sigma}_u \tilde{\mathbf{V}}_u^H$.
- 7: Calculate $\mathbf{F}_{RFu} = e^{j\angle \tilde{\mathbf{V}}_{u1}}$.
- 8: **end**

Outputs:
Analog precoder $\mathbf{F}_{RF} = [\mathbf{F}_{RF1}, \mathbf{F}_{RF2}, \dots, \mathbf{F}_{RFU}]$ and analog combiner $\mathbf{W}_{RFu}, u = 1, \dots, U$.

After solving the problem in the analog beamformer design stage, a baseband equivalent channel is formed by the result of the multiplication of the channel and the designed analog beamformer. Therefore, the equivalent baseband channel for the u -th user on the k -th subcarrier is expressed as

$$\mathbf{H}_{\text{equ}}[k] = \mathbf{W}_{RFu}^H \mathbf{H}_u[k] \mathbf{F}_{RF}. \quad (17)$$

Based on this baseband equivalent channel, the low-dimension BD digital beamformer discussed earlier may be applied to cancel inter-user interference. However, while the condition $N_{tRF} < UN_{rRF}$ occurs, the baseband equivalent channel could not be used to perform the BD algorithm, canceling inter-user interference completely. It means that the algorithm could not find all required null spaces to interferers for users. Unfortunately, this condition is inevitable if the resource allocation algorithm such as flexible data stream adjustment is considered. A joint processing idea such as [45] called ‘‘coordinated transmit-receive processing’’ was proposed for the application to a fully digital beamforming system. Herein, a joint transmit-receive processing scheme is developed to solve this hybrid beamforming problem under consideration to relax the RF chain number constraint based on an equivalent channel idea. The proposed scheme is derived as follows.

First, let $\check{\mathbf{W}}_u[k]$ be a receiving combiner for the u -th user on the k -th subcarrier that will receive data from the base station. The new equivalent baseband channel for all users is formed to be a block matrix as

$$\begin{aligned} \check{\mathbf{H}}_{\text{eq}}[k] &= [\check{\mathbf{H}}_1^T[k], \dots, \check{\mathbf{H}}_U^T[k]]^T \\ &= [(\check{\mathbf{W}}_1^H[k] \mathbf{H}_{\text{eq}1}[k])^T, \dots, (\check{\mathbf{W}}_U^H[k] \mathbf{H}_{\text{eq}U}[k])^T]^T. \end{aligned} \quad (18)$$

The proposed joint transmit-receive processing scheme is performed on $\check{\mathbf{H}}_{\text{eq}}[k]$ instead of the baseband equivalent channel as the input of **Algorithm 2**. Some inter-user interference is allowed in the transmit signals; it means interference is not completely canceled in the transmit. The residual interference is dependent on the nulling of the beam pattern $\check{\mathbf{W}}_u[k]$. In other words, it aims to be canceled after the combiner output.

Based on the above discussion, the next step is to determine the expression of $\check{\mathbf{W}}_u[k]$. A baseband equivalent channel is performed by SVD and expressed as

$$\mathbf{H}_{\text{equ}}[k] = \check{\mathbf{U}}_u[k] \check{\Sigma}_u[k] \check{\mathbf{V}}_u^H[k]. \quad (19)$$

Then, the receiving combiner for the u -th user on the k -th subcarrier may be conjectured as

$$\check{\mathbf{W}}_u[k] = \check{\mathbf{U}}_{u1}[k] \quad (20)$$

where $\check{\mathbf{U}}_{u1}[k]$ is the first $n_{s,u}$ columns of the matrix $\check{\mathbf{U}}_u[k]$, because the beamformer is temporarily assumed by the transmitter on the best combiner structure, and the beamformer is not necessarily the result of the final combiner.

After the above processing, the digital beamformer is further imposed by the following constraint to eliminate the inter-user interference.

$$\check{\mathbf{H}}_i[k] \mathbf{F}_j[k] = \mathbf{0} \quad \text{for } i \neq j \quad (21)$$

where $\check{\mathbf{H}}_i[k]$ is the new equivalent baseband channel for the i -th user on the k -th subcarrier and $\mathbf{F}_j[k]$ is the low-dimension digital precoder for the j -th user on the k -th subcarrier.

Then the new equivalent baseband interference channel is constructed for the u -th user on the k -th subcarrier as

$$\begin{aligned} \check{\check{\mathbf{H}}}_u[k] &= [\check{\check{\mathbf{H}}}_1^T[k], \dots, \check{\check{\mathbf{H}}}_{u-1}^T[k], \check{\check{\mathbf{H}}}_{u+1}^T[k], \dots, \check{\check{\mathbf{H}}}_U^T[k]]^T. \end{aligned} \quad (22)$$

The zero-interference constraint makes $\mathbf{F}_u[k]$ lie in the null space of $\check{\check{\mathbf{H}}}_u[k]$. SVD is performed to find the null space of the new equivalent baseband interference channel.

$$\check{\check{\mathbf{H}}}_u[k] = \check{\mathbf{U}}_u[k] \check{\Sigma}_u[k] [\check{\mathbf{V}}_{u1}[k] \check{\mathbf{V}}_{u2}[k]]^H \quad (23)$$

where $\check{\mathbf{V}}_{u1}[k]$ is composed of the first $\text{rank}(\check{\check{\mathbf{H}}}_u[k])$ right singular vectors, and $\check{\mathbf{V}}_{u2}[k]$ has the last $N_{tRF} - \text{rank}(\check{\check{\mathbf{H}}}_u[k])$ right singular vectors associated with zero singular values.

Therefore, $\check{\mathbf{V}}_{u2}[k]$ forms an orthogonal basis for the null space of $\check{\check{\mathbf{H}}}_u[k]$. We project the new equivalent baseband channel $\check{\mathbf{H}}_u[k]$ onto the null space to obtain an effective channel without interference expressed as

$$\check{\mathbf{H}}_{\text{eff}u}[k] = \check{\mathbf{H}}_u[k] \check{\mathbf{V}}_{u2}[k]. \quad (24)$$

In the absence of interference, the precoder and the combiner can be designed based on SVD performed on this channel as

$$\check{\mathbf{H}}_{\text{eff}u}[k] = \hat{\mathbf{U}}_u[k] \hat{\Sigma}_u[k] \hat{\mathbf{V}}_u^H[k]$$

$$= \left[\hat{\mathbf{U}}_{u1}[k] \hat{\mathbf{U}}_{u2}[k] \right] \hat{\mathbf{\Sigma}}_u[k] \left[\hat{\mathbf{V}}_{u1}[k] \hat{\mathbf{V}}_{u2}[k] \right]^H \quad (25)$$

where $\hat{\mathbf{U}}_{u1}[k]$ is the first $n_{s,u}$ columns of the matrix $\hat{\mathbf{U}}_u[k]$, $\hat{\mathbf{V}}_{u1}[k]$ is the first $n_{s,u}$ columns of the matrix $\hat{\mathbf{V}}_u[k]$, and $\hat{\mathbf{\Sigma}}_u[k]$ is the non-negative diagonal matrix constituted by the singular values of $\hat{\mathbf{H}}_{\text{eff}u}[k]$.

Finally, the multiplication of $\tilde{\mathbf{V}}_{u2}[k]$ and the first $n_{s,u}$ columns of $\tilde{\mathbf{V}}_u[k]$ is considered as the digital precoder to cancel some inter-user interference. At the receiver, the multiplication of $\tilde{\mathbf{W}}_u[k]$ and the first $n_{s,u}$ columns of $\hat{\mathbf{U}}_u[k]$ is used as the digital combiner to cancel residual inter-user interference and inter-stream interference. This proposed processing scheme has greater flexibility in serving the number of users because it avoids the above-mentioned constraint regarding the serving number of users. The entire process of digital beamformer design is shown by the pseudo-code in *Algorithm 3-2*, denoted as Proposed Hybrid Beamforming Algorithm (Digital).

Algorithm 3-2 Proposed Hybrid Beamforming Algorithm (Digital)

- 1: **for** every k -th subcarrier **do**
- 2: **for** every u -th user **do**
- 3: Define $\mathbf{H}_{\text{equ}}[k] = \mathbf{W}_{\text{RF}u}^H \mathbf{H}_u[k] \mathbf{F}_{\text{RF}}$.
- 4: Calculate SVD of $\mathbf{H}_{\text{equ}}[k]$ by (19).
- 5: Define $\tilde{\mathbf{H}}_u[k] = \tilde{\mathbf{U}}_{u1}^H[k] \mathbf{H}_{\text{equ}}[k]$.
- 6: **end**
- 7: **for** every u -th user **do**
- 8: Define new equivalent baseband interference Channel by (22).
- 9: Calculate the null space of the new equivalent baseband interference channel by (23).
- 10: Calculate SVD of effective channel by (24).
- 11: Calculate $\tilde{\mathbf{F}}_{\text{BB}u}[k] = \tilde{\mathbf{V}}_{u2}[k] \hat{\mathbf{V}}_{u1}[k]$.
- 12: Calculate $\mathbf{W}_{\text{BB}u}[k] = \mathbf{U}_{u1}[k] \hat{\mathbf{U}}_{u1}[k]$.
- 13: **end**
- 14: **end**
- 15: Obtain digital precoder and digital combiner
 $\tilde{\mathbf{F}}_{\text{BB}}[k] = [\mathbf{F}_{\text{BB}1}[k], \dots, \mathbf{F}_{\text{BB}U}[k]]$, $k = 1, \dots, K$
 $\mathbf{W}_{\text{BB}}[k] = [\mathbf{W}_{\text{BB}1}[k], \dots, \mathbf{W}_{\text{BB}U}[k]]$,
 $k = 1, \dots, K$.
- 16: For digital precoder at the transmitter, normalize
 $\mathbf{F}_{\text{BB}}[k] = \frac{\sqrt{N_s}}{\|\mathbf{F}_{\text{RF}} \tilde{\mathbf{F}}_{\text{BB}}[k]\|_F} \tilde{\mathbf{F}}_{\text{BB}}[k]$.

Outputs: $\mathbf{W}_{\text{BB}}[k]$ and $\mathbf{F}_{\text{BB}}[k]$, $k = 1, \dots, K$.

The above three beamforming algorithms are developed to cancel interference for solving the formulated problem and particularly for meeting the BER/BLER constraint by using practical modulation and coding. One of the key issues is that the MCS index allocation algorithm to select appropriate modulation and coding to transmit is required after appropriately controlling over all interferences such that the switching levels would be applied to satisfy the system's specified BER/BLER. In the next part, the proposed MCS

TABLE 1. SNR switching levels for modulation and coding schemes satisfying 10% block error rates.

MCS Index	Modulation	Code Rate	Equivalent Loading Bits	SNR Threshold
1	QPSK	0.1885	0.3770	-4.3591 (dB)
2	QPSK	0.5879	1.1758	1.9976 (dB)
3	16-QAM	0.6016	2.4063	8.0591 (dB)
4	16-QAM	0.6504	3.9023	13.4893 (dB)
5	64-QAM	0.9258	5.5547	19.2155 (dB)

index allocation algorithm is derived in detail. This consideration is rarely investigated in hybrid beamforming systems for multi-user multi-carrier scenarios.

D. PROPOSED MCS INDEX ALLOCATION ALGORITHM

The issue of the switching levels for modulation and coding is addressed as follows. In the performance curves of SNR-BLER for 5G NR systems are presented. In 3GPP 38.212 [46], the LDPC code replaces the turbo code used in the 4G LTE data channels, and the polar code replaces the convolutional code used in the 4G LTE control channels. Once the switching level is obtained, the proposed allocation schemes can be applied, and a similar performance trend is observed. The CQI table for the LDPC code in is adopted here as an example of the modulation and coding schemes. This table provides fifteen schemes, and each corresponds to an MCS index. Five out of these fifteen schemes were extracted and employed for simulation, and the related parameters are listed in Table 1. The target BLER is set to 10% by the 3GPP standard. The SNR of this table provides the switching level for each MCS index satisfying 10% BLER.

First, the MCS_u is denoted as the MCS index allocation table to indicate the selected modulation and coding schemes used by the u -th user on different data streams and subcarriers and is initialized as

$$MCS_u = [\mathbf{0}_{n_{s,u} \times K}]. \quad (26)$$

The proposed novel approach is addressed as follows. An MCS index corresponds to a transmission with equivalent loading bits for performing typical bit loading algorithms. Therefore, the mapping to the spectral efficiency as the equivalent loading bits for the n -th data stream on the k -th subcarrier is expressed as

$$SE(n, k) = g_k(MCS_u(n, k)) \quad (27)$$

where $MCS_u(n, k)$ is the assigned MCS index for the n -th data stream on the k -th subcarrier for the u -th user, and $g_k(\cdot)$ is a mapping function for a specific MCS index mapped to equivalent loading bits according to Table 1. The MCS index assignment corresponding to the equivalent loading bits is iteratively evaluated one-by-one until each user achieves the target data rate. The above idea is similar to that of the bit loading process, where the assignment is based on the required minimum transmission power per bit during each MCS index evaluation iteration.

The transmission power increment table is denoted as

$$\Delta P_u = [0_{n_{s,u} \times K}] \quad (28)$$

where each element in ΔP_u represents the increased transmission power per additional transmit bit on all data streams and subcarriers. The expression is

$$\Delta P_u(n, k) = \frac{\Delta SINR_u(n, k) \left\| \mathbf{w}_{BBu,n}^H[k] \mathbf{W}_{RFu}^H \right\|^2 \sigma_n^2}{\Delta R_u(n, k) \left\| \mathbf{w}_{BBu,n}^H[k] \mathbf{W}_{RFu}^H \mathbf{H}_u[k] \mathbf{F}_{REF} \mathbf{F}_{BBu,n}[k] \right\|^2} \quad (29)$$

where $\Delta SINR_u(n, k)$ is the increased SINR for the n -th data stream on the k -th subcarrier switched to the next level MCS index, and $\Delta R_u(n, k)$ is the associated increased number of bits.

The entire process of the MCS index allocation algorithm is shown by the pseudo-code in *Algorithm 4*, denoted as the Proposed MCS Index Allocation Algorithm.

Algorithm 4 Proposed MCS Index Allocation Algorithm

- 1: **for** every u -th user **do**
- 2: bits $\leftarrow b$.
- 3: Define $\mathbf{W}_{BBu}[k]$ and $\mathbf{F}_{BBu}[k]$ by (10).
- 4: Initialize the MCS index allocation table by (26).
- 5: Initialize the transmission power increment table by (28).
- 6: Calculate $\Delta P_u(n, k)$, for all n, k .
- 7: **repeat**
- 8: $(n, k) = \arg \min_{n,k} \Delta P_u(n, k)$.
- 9: $MCS_u(n, k) \leftarrow MCS_u(n, k) + 1$.
- 10: Obtain spectral efficiency by (27), and calculate the increased spectral efficiency $\Delta SE(n, k)$.
- 11: Update $\Delta SINR_u(n, k)$ and $\Delta R_u(n, k)$ to next MCS index, then update $\Delta P_u(n, k)$.
- 12: bits \leftarrow bits $- \Delta SE(n, k)$.
- 13: **until** bits ≤ 0
- 14: **end**

E. PROPOSED STREAM INCREMENTAL ALGORITHM (SIA)

Existing millimeter-wave hybrid beamforming algorithms usually assume that all the users transmit the same number of data streams. Herein, we propose algorithms to allocate different numbers of data streams dynamically for each user according to the channel state information of all users. The idea of the flexible data stream assignment and the above proposed hybrid beamforming along with the MCS allocation schemes are integrated to be the proposed processing procedures, as presented in Fig. 2 to solve the optimization problem in this study.

NS_C is denoted as the data stream allocation table for the user set C as the number of data streams assigned to the users,

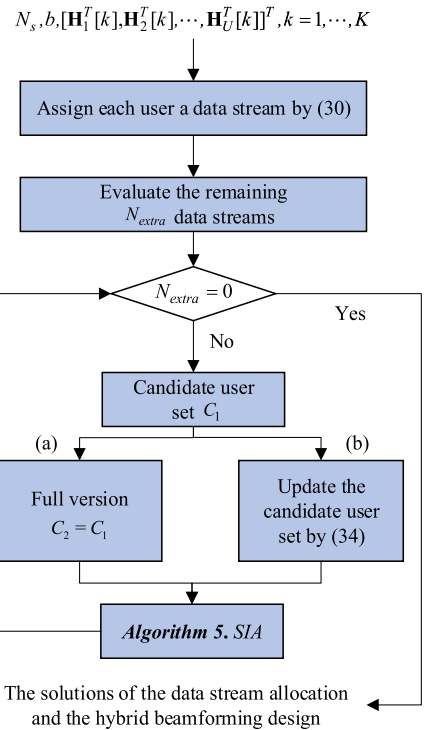

FIGURE 2. Flow chart of the proposed processing scheme.

which is initialized:

$$NS_C = [n_{s,1}, n_{s,2}, \dots, n_{s,U}] = [1_{1 \times U}] \quad (30)$$

where $n_{s,u}$ is the number of received data streams by the u -th user.

$$N_{extra} = N_s - \sum_{i=1}^U n_{s,i}. \quad (31)$$

If more available data streams need to be transmitted at the base station, the incremental algorithm is performed to allocate the additional data streams based on the criterion of minimizing the total transmission power. In other words, the case of maximum reduced power is selected while an additional data stream is allocated. This rule is repeated iteratively until all of the available data streams are completely assigned.

The received data streams for a user can be demodulated and requires $n_{s,u} \leq N_{rRF}$. In running the proposed algorithm, candidate users set C_1 for data stream allocation is formed if satisfying

$$C_1 = \{u | n_{s,u} < N_{rRF}, u \in C\}. \quad (32)$$

First, one version of the proposed schemes, called the full version, is performed by running the procedure through the block labeled (a) of Fig. 2. Each candidate user tries to allocate an additional data stream, and the required power associated with the beamformer is calculated. The case with the lowest power requirement is selected to allocate accordingly. This process repeats until $N_{extra} = 0$.

Next, the reduced complexity version is proposed, which is performed through the block labeled (b) in Fig. 2. The

version is proposed based on the observation that there is a low probability that multiple data streams would be allocated to those users with better channel state information for the formulated problem under consideration. Therefore, a few users with better channel state information are removed from the candidate set at the starting point of the processing. The details are as follows.

Based on the path losses of users, a pass loss table is created as

$$\mathbf{PL}_{C_1} = [pl_1, \dots, pl_{Card(C_1)}] \quad (33)$$

where \mathbf{PL}_{C_1} is the path loss table for the users in set C_1 , and pl_u is the path loss in dB for the u -th user in set C_1 . The value of this path loss may be estimated from the base station transmit signal with known power to the user equipment, and each user would perform the estimation task and report it to the base station.

A threshold Υ is set to remove some users with a lower probability of obtaining multiple data stream assignments. After the screening, the resulting candidate set is expressed as

$$C_2 = \{u \mid pl_u > \max(\mathbf{PL}_{C_1}) - \Upsilon, u \in C_1\} \quad (34)$$

where C_2 is the modified set of the candidates. While setting a higher value of Υ , it will be closer to the performance of the version with the full user set, but the complexity increases. The performance loss becomes significant if the value of Υ is too small. Therefore, the value Υ is a trade-off between performance and complexity.

Algorithm 5 Proposed Stream Incremental Algorithm

```

1: if ( $Card(C_2) = 1$ )  $\cap N_{extra} > 1$ 
2:    $k \in C_2, n_{s,k} \leftarrow n_{s,k} + 1.$ 
3:    $N_{extra} \leftarrow N_{extra} - 1.$ 
4: else
5:   Initialize the transmitted power table
    $\mathcal{P} = [p_1, p_2, \dots, p_{Card(C_2)}] = [\mathbf{0}_{1 \times Card(C_2)}].$ 
6:   for every  $i$ -th candidate user do
7:      $n_{s,i} \leftarrow n_{s,i} + 1.$ 
8:      $N_{temp} = n_{s,1} + n_{s,2} + \dots + n_{s,U}.$ 
9:     Execute Beamforming Design Algorithm.
10:    Execute MCS Index Allocation Algorithm.
11:    According to  $\mathbf{MCS}_u$ , calculate  $p_i.$ 
12:     $n_{s,i} \leftarrow n_{s,i} - 1.$ 
13:   end
14:    $Index = \arg \min(p_u).$ 
15:    $n_{s,Index} \leftarrow n_{s,Index} + 1.$ 
16:    $N_{extra} \leftarrow N_{extra} - 1.$ 
17: end

```

The entire process of the stream incremental algorithm is shown by the pseudo-code in **Algorithm 5**, denoted as the Proposed Stream Incremental Algorithm.

IV. COMPUTATIONAL COMPLEXITY

In this section, the complexities of the proposed algorithms are analyzed. Regarding the analog beamforming design, the analog combiner \mathbf{W}_{RFu} is obtained by calculating the SVD of $\mathbf{H}_u^{(h)}$, and $\mathbf{H}_u^{(h)}$ is the $N_r \times (N_t K)$ horizontal tensor unfolding of the three-dimensional matrix for all subcarrier channels. According to some numerical analysis skills [47], we do not need to perform the full SVD of \mathbf{W}_{RFu} because only the largest N_{rRF} singular values and their associated singular vectors are needed. Therefore, the required complexity to calculate \mathbf{W}_{RFu} was $\mathcal{O}(N_{rRF} N_r K N_t)$. After all of the analog combiners for all users are designed, the analog combiner and the frequency domain channel are multiplied as an equivalent channel $\mathbf{H}_{effu}^{(l)}$ to design the analog precoder. $\mathbf{H}_{effu}^{(l)} = [(\mathbf{W}_{RFu}^H \mathbf{H}_u[1])^T, \dots, (\mathbf{W}_{RFu}^H \mathbf{H}_u[K])^T]^T$ is the $(N_{rRF} K) \times N_t$ longitudinal tensor unfolding of the three-dimensional matrix for all equivalent subcarrier channels. The multiplication of the two matrices is performed K times, so the complexity required to calculate $\mathbf{H}_{effu}^{(l)}$ is $\mathcal{O}(N_{rRF} N_r N_t K)$. After that, the analog precoder \mathbf{F}_{RFu} is obtained by calculating the SVD of $\mathbf{H}_{effu}^{(l)}$ and taking the first $n_{s,u}$ columns of the matrix $\check{\mathbf{V}}_u$. Therefore, the required complexity to calculate \mathbf{F}_{RFu} is $\mathcal{O}(n_{s,u} K N_{rRF} N_t)$. The above is analyzed per user, and the computation can be performed in parallel. The iteration needs N_{avg} times on average, so the overall complexity of the analog beamformer design is

$$\mathcal{O}(N_{avg} K N_{rRF} N_t (N_r + n_{s,u})).$$

In digital beamforming design, the baseband equivalent channel $\mathbf{H}_{equ}[k]$ is obtained by the multiplication of the channel and the analog beamformer; $\mathbf{H}_{equ}[k] = \mathbf{W}_{RFu}^H \mathbf{H}_u[k] \mathbf{F}_{RF}$. The term $\mathbf{W}_{RFu}^H \mathbf{H}_u[k]$ has been already obtained in the previous step and needs not be calculated again. Then, the complexity of multiplying two matrices is obtained as $\mathcal{O}(N_{rRF} N_t N_{rRF})$. $\check{\mathbf{H}}_u[k] = \check{\mathbf{W}}_u^H[k] \mathbf{H}_{equ}[k]$ is formed as the new equivalent baseband channel, where $\check{\mathbf{W}}_u[k] = \check{\mathbf{U}}_{u1}[k]$ is the one component of the cascaded receiving combiner from the SVD of $\mathbf{H}_{equ}[k]$. In addition, the largest $n_{s,u}$ singular values and their associated singular vectors are needed. Therefore, the complexity to calculate $\check{\mathbf{U}}_{u1}[k]$ and $\check{\mathbf{H}}_u[k]$ is $\mathcal{O}(n_{s,u} N_{rRF} N_{rRF})$. Based on (22), the null space of the constructed equivalent baseband interference channel $\check{\check{\mathbf{H}}}_u[k]$ is obtained by the SVD of $\check{\check{\mathbf{H}}}_u[k]$. Therefore, the complexity to calculate the null space $\check{\check{\mathbf{V}}}_{u2}[k]$ is $\mathcal{O}((N_s - n_{s,u})^2 N_{rRF})$. Then, the projection of the new equivalent baseband channel onto the null space to obtain the effective channel without interference $\check{\check{\mathbf{H}}}_{effu}[k] = \check{\check{\mathbf{H}}}_u[k] \check{\check{\mathbf{V}}}_{u2}[k]$ requires multiplication of two matrices and the complexity is $\mathcal{O}(n_{s,u}^2 N_{rRF})$. To design $\mathbf{F}_{BBu}[k]$ and $\mathbf{W}_{BBu}[k]$, the SVD of $\check{\check{\mathbf{H}}}_{effu}[k]$ is computed. It follows that the complexity to calculate $\check{\check{\mathbf{V}}}_{u1}[k]$ and $\check{\check{\mathbf{U}}}_{u1}[k]$ is $\mathcal{O}(n_{s,u}^3)$. Finally, the digital precoder as $\mathbf{F}_{BBu}[k] = \check{\check{\mathbf{V}}}_{u2}[k] \check{\check{\mathbf{V}}}_{u1}[k]$ and the digital combiner as $\mathbf{W}_{BBu}[k] = \check{\check{\mathbf{U}}}_{u1}[k] \check{\check{\mathbf{U}}}_{u1}[k]$ are formed. Therefore, the complexities of multiplying two matrices are $\mathcal{O}(N_{rRF} n_{s,u}^2)$ and

$\mathcal{O}(N_{rRF}n_{s,u}^2)$, respectively. The above complexity is analyzed for a single user on a single subcarrier basis. It could be processed in parallel for U users and K subcarriers, and each is performed N_{avg} times on average. Therefore, the total complexity of the digital beamformer design is

$$\mathcal{O}(N_{avg}(N_{rRF}N_tN_{tRF} + n_{s,u}N_{rRF}N_{tRF} + (N_s - n_{s,u})^2 N_{tRF} + n_{s,u}^2 N_{tRF} + n_{s,u}^3 + N_{rRF}n_{s,u}^2)).$$

In the last step of the digital beamformer design, we normalize to satisfy the power constraint. It has shown in line 16 for **Algorithm 3-2**. First, we calculate $\mathbf{F}_{RF}\tilde{\mathbf{F}}_{BB}[k]$. Therefore, the complexity required to multiply two matrices is $\mathcal{O}(N_tN_{tRF}N_s)$. Next, we multiply the calculated value with $\tilde{\mathbf{F}}_{BB}[k]$ to complete the normalization. Therefore, the complexity of multiplying the value and the matrix is $\mathcal{O}(N_tN_{tRF}N_s)$. The above is a complexity analysis for a single subcarrier. We then processed K subcarriers in parallel, and each subcarrier is performed N_{avg} times on average; the overall complexity of digital beamformer normalization is

$$\mathcal{O}(N_{avg}N_tN_{tRF}N_s(N_t + 1)) = \mathcal{O}(N_{avg}N_tN_{tRF}N_sN_t).$$

In the MCS index allocation, each element in the transmission power increment table is required to be calculated. For each element in $\Delta\mathbf{P}_u$, $\mathbf{w}_{BBu,n}^H[k]\mathbf{W}_{RFu}^H$ in the numerator is calculated and the complexity to multiply these two matrices is $\mathcal{O}(N_{rRF}N_r)$. Similarly, $\mathbf{w}_{BBu,n}^H[k]\mathbf{W}_{RFu}^H\mathbf{H}_u[k]\mathbf{F}_{RF}\mathbf{f}_{BBu,n}[k]$ in the denominator is calculated and $\mathbf{w}_{BBu,n}^H[k]\mathbf{W}_{RFu}^H$ has already been obtained in the previous step. Therefore, the complexity to multiply these matrices is $\mathcal{O}(N_rN_t + N_tN_{tRF} + N_{tRF})$. The above complexity is analyzed for calculating the initial value of the transmission power increment table. The initialization process is analyzed per user, and the computation is performed in parallel and it is executed N_{avg} times on average. In the iterative procedure, the worst-case is evaluated so that all elements are updated to the last MCS index denoted I_{max} , where each element in this table may iterate to MCS index I_{max} . So the overall complexity of MCS index allocation is

$$\mathcal{O}(N_{avg}Kn_{s,u}(N_rN_t + N_tN_{tRF} + N_{tRF} + N_{rRF}N_r + I_{max})).$$

V. SIMULATION RESULTS

In this section, the performances of the various schemes are presented to show the efficacy of the proposed schemes. The downlink of the base station is considered to serve the users randomly distributed in the cell with a TDD mode. The entire channel bandwidth was 3.84 MHz, and it was divided into $K = 16$ subcarriers using the OFDM transmission to combat the multipath fading. The subcarrier spacing was 240 kHz. The cluster powers $P_l, l = 0, \dots, N_{cl} - 1$ follow the exponential delay distribution as defined in 3GPP 38.900 [48]. Moreover, the path loss pl_u for the u -th user was generated by the path loss model of the NLOS UMi-Street Canyon scenario in 3GPP 38.901 [49]. The remaining simulation settings are described as follows:

TABLE 2. Average number of executions N_{avg} of the proposed schemes in figs. 3-5.

γ (Fig. 3)	N_{avg}		
	SIA	Reduced Complexity SIA	
5	4.00	1.46	
10	4.00	1.96	
15	4.00	2.44	
20	4.00	2.85	
d (Fig. 4)	SIA	Reduced Complexity SIA	
	50	4.00	2.00
	100	4.00	1.96
	150	4.00	1.95
	200	4.00	1.95
N_t (Fig. 5)	SIA	Reduced Complexity SIA	
	128	4.00	1.96
	160	4.00	1.97
	192	4.00	1.97

- Noise density -174 dBm/Hz
- Millimeter-wave frequency $f_c = 28$ GHz
- Frame duration $T_f = 10$ ms
- Data rate for each user $R = 8.4$ Mbps
- Switch level in Table 1.
- Cell radius $d = 100$ m
- Number of BS antennas $N_t = 128$
- Number of BS RF chains $N_{tRF} = 5, 8$
- BS antenna height $h_{BS} = 10$ m
- Number of UE antennas $N_r = 16$
- Number of UE RF chains $N_{rRF} = 3$
- UE antenna height $h_{UE} \in U \sim [1.5, 22.5]$ m
- RMS delay spread $DS = 66$ ns
- Delay distribution proportionality factor $r_\tau = 2.1$
- Per cluster shadowing std $\zeta = 3$
- Number of the cluster $N_{cl} = 5$
- Number of the ray $N_{ray} = 10$
- Angle spread $\theta_{as} = 10^\circ$

These simulations were categorized into two parts. First, we considered the scenario of the base station transmitting $N_s = 5$ data streams and simultaneously serving $U = 4$ users.

In the beamforming method, we compared various schemes along with different scenarios in Figs. 3-9. Among these schemes under comparison, one is the fully digital BD beamforming scheme mentioned earlier, which is expected to achieve sub-optimal performance; another is the proposed hybrid beamforming scheme. In the comparison for data stream allocation, three allocation methods were compared, including the random assignment, the stream incremental algorithm (SIA), and the reduced complexity stream incremental algorithm. As revealed in the simulation result in Fig. 3, the use of the stream incremental algorithm to dynamically allocate resources can reduce the transmission power of the base station. The performance improvement by allocating different numbers of data streams for users according to the channel state information is significant. Regardless

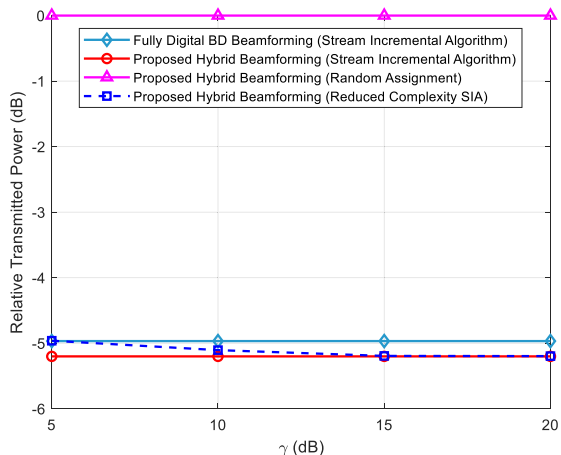

FIGURE 3. Relative transmitted power versus γ of different methods for the 128×16 OFDM MIMO system; four users, $N_{tRF} = 5$, $N_s = 5$, and $N_{rRF} = 3$.

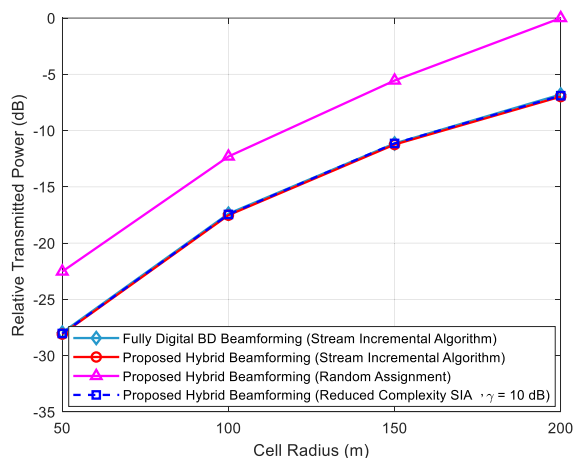

FIGURE 4. Relative transmitted power versus cell radius of different methods for the 128×16 OFDM MIMO system; four users, $N_{tRF} = 5$, $N_s = 5$, and $N_{rRF} = 3$.

of whether the beamforming scheme uses the fully digital BD or the proposed methods, the total power is reduced by approximately 5dB compared with the random assignment scheme. In addition, the proposed hybrid beamforming scheme achieves comparable performance to that of the fully digital BD scheme. As observed from the simulation result of Fig. 3 and Table 2, while setting $\gamma = 10$ dB, the proposed reduced complexity SIA can achieve a good trade-off between complexity and performance.

Under this setting, the relative transmitted power by base stations in different coverage areas is also evaluated. As revealed in Fig. 4, while the cell radius increases, the required transmission power of the base station will also increase. A base station with a cell radius of two hundred meters requires approximately 10 dB more transmission power than that of a cell radius of one hundred meters on average in the system under consideration. In addition, the proposed hybrid beamforming schemes achieved a perfor-

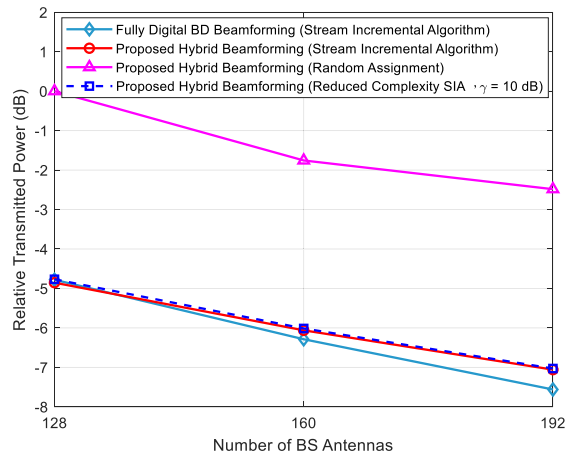

FIGURE 5. Relative transmitted power versus the number of BS antennas of different methods for the OFDM MIMO system; four users, $N_{tRF} = 5$, $N_s = 5$, and $N_{rRF} = 3$.

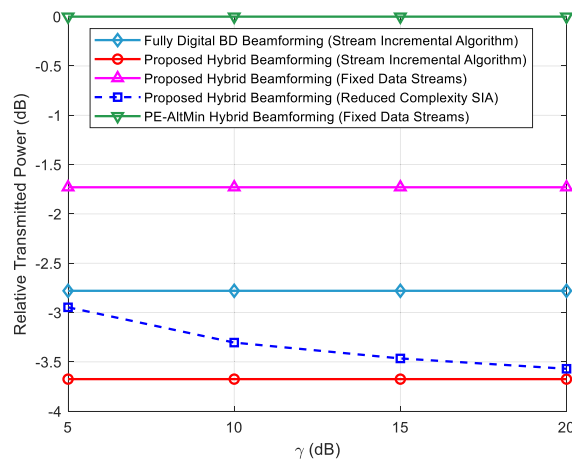

FIGURE 6. Relative transmitted power versus γ of different methods for the 128×16 OFDM MIMO system, four users, $N_{tRF} = 8$, $N_s = 8$, and $N_{rRF} = 3$.

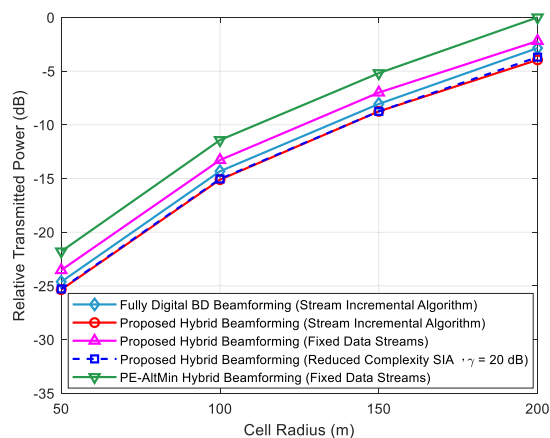

FIGURE 7. Relative transmitted power versus cell radius of different methods for the 128×16 OFDM MIMO system, four users, $N_{tRF} = 8$, $N_s = 8$, and $N_{rRF} = 3$.

mance very close to that of the fully digital BD scheme, where the number of RF chains reduced from 128 to 5. It improved the implementation feasibility and the cost of large antenna

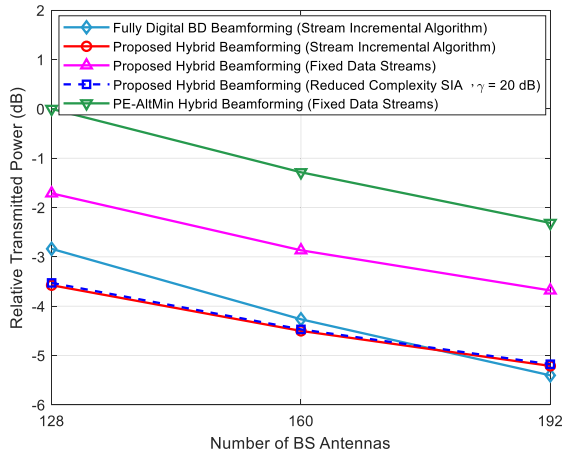

FIGURE 8. Relative transmitted power versus the number of BS antennas of different methods for the OFDM MIMO system, four users, $N_{tRF} = 8$, $N_s = 8$, and $N_{rRF} = 3$.

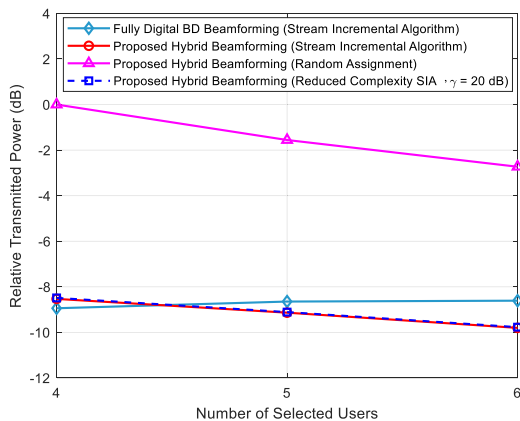

FIGURE 9. Relative transmitted power versus the number of selected users of different methods for the 192×16 OFDM MIMO system; $N_{tRF} = 8$, $N_s = 8$, $N_{rRF} = 3$, and system sum rate = 39.2 Mbps.

array systems. As observed in Fig. 5, as the number of transmit antennas increased, the required transmission power of the base station decreased. The power of the fully digital BD scheme decreased faster than that of the proposed hybrid scheme. This reason would be that the performance of the fully digital BD beamforming scheme is affected by the antenna numbers. When the value of N_t is much larger than UN_r , the system can achieve better performance. As the value of N_t is close to UN_r , the overall performance may degrade.

In the second part of the simulation, we considered the scenario of the base station with $N_{tRF} = 8$ RF chains transmitting $N_s = 8$ data streams and simultaneously serving $U = 4$ users. The other parameters remain unchanged; one more scheme, the modified PE-AltMin beamforming scheme, was included for comparison. Note that the existing hybrid beamforming algorithm designs in the literature assume all users were allocated with an equal number of data streams.

Based on the simulation results in Fig. 6, the benefit of the dynamic assignment on the numbers of data streams for

TABLE 3. Average number of executions N_{avg} of proposed schemes for figs. 6-9.

γ (Fig. 6)	Average Number of Executions N_{avg}	
	SIA	Reduced Complexity SIA
5	14.90	4.54
10	14.90	7.27
15	14.90	9.42
20	14.90	11.07
d (Fig. 7)	SIA	
	50	14.91
	100	14.90
	150	14.89
200	14.89	10.85
N_t (Fig. 8)	SIA	
	128	14.90
	160	14.89
	192	14.91
		Reduced Complexity SIA
U (Fig. 9)	SIA	
	4	14.86
	5	14.68
	6	12.00
		Reduced Complexity SIA
		11.06
		11.04
		11.10
		11.05
		10.16
		7.77

users is also verified. In Fig. 6, two schemes use fixed data stream allocation, and the performances are worse than those of the other three schemes. Even though these two schemes use fixed data stream allocation, the transmission power of our proposed hybrid beamforming scheme is about 1.7dB lower than the modified PE-AltMin algorithm. In addition, the proposed hybrid beamforming scheme, even with the reduced complexity version of SIA, outperforms the fully digital BD scheme for $\Upsilon = 5, 10, 15$, and 20dB, respectively.

Similar to the previous simulation, the required transmission power for various cell radiuses were also evaluated. As indicated in the simulation results of Fig. 7, a similar performance trend was observed. A base station with a cell radius of two hundred meters required approximately 10 dB more transmission power than that of the cell radius of one hundred meters on average. Similarly, in Fig. 8, while the antenna numbers increased in the simulation, the required transmission power reduced. These results are consistent with the previous simulation results.

Finally, the impact on performance by varying numbers of users was evaluated. An increase in the number of users had a big impact on the performance of the fully digital BD beamforming scheme, as mentioned before; the results increased significantly in the required power. To avoid this issue, the number of the base station antennas was increased to $N_t = 192$ while the other parameters remained unchanged. The total data rate of the base station was fixed at 39.2 Mbps, and then the system allocated the resources by varying the number of users. Due to the multi-user diversity and the inter-user interference was appropriately controlled, the power requirement could be reduced. While the amount of interference was beyond the suppression capability of the beamforming mechanism, it led to an increase in the required power significantly.

From the simulation results in Fig. 9, the required power of the proposed method decreased by approximately more than 1 dB as the number of users increased from four to six. On the contrary, the required power by employing the fully digital BD beamforming scheme could not be improved by increasing the number factor of users. Thus, the proposed method has better capability in handling the interference effect.

VI. CONCLUSION

In this study, we considered the hybrid beamforming and the data stream allocation algorithm designs for a multi-carrier millimeter-wave massive MIMO system. The formulated optimization problem was to minimize the transmission power under a certain quality-of-service (QoS), such as bit/block error rates and data rates for each user, where the switching levels of practical modulation and coding schemes were considered. To achieve the goal of the bit/block error rates, the interference effect needed to be controlled and canceled. Therefore, the beamforming schemes were developed. Our proposed hybrid beamforming algorithms aimed to harvest the large array gain through the analog beamformer design and then cancel the interference by the digital beamformer based on an idea of the equivalent baseband channel.

Our proposed algorithms have better flexibility in serving the number of users. Simulation results demonstrated that the proposed schemes outperformed the adapted existing schemes for the formulated problem. The proposed novel idea of allocating different numbers of data streams for users was dynamically able to improve performance. Particularly, simulation results verified that the proposed schemes with a lower implementation complexity could achieve comparable performance to those of a fully digital BD algorithm.

REFERENCES

- [1] T. S. Rappaport, S. Sun, R. Mayzus, H. Zhao, Y. Azar, K. Wang, G. N. Wong, J. K. Schulz, M. Samimi, and F. Gutierrez, "Millimeter wave mobile communications for 5G cellular: It will work!" *IEEE Access*, vol. 1, pp. 335–349, 2013.
- [2] F. Boccardi, R. W. Heath, Jr., A. Lozano, T. L. Marzetta, and P. Popovski, "Five disruptive technology directions for 5G," *IEEE Commun. Mag.*, vol. 52, no. 2, pp. 74–80, Feb. 2014.
- [3] P. Wang, Y. Li, L. Song, and B. Vucetic, "Multi-gigabit millimeter wave wireless communications for 5G: From fixed access to cellular networks," *IEEE Commun. Mag.*, vol. 53, no. 1, pp. 168–178, Jan. 2015.
- [4] F. Rusek, D. Persson, B. K. Lau, E. G. Larsson, T. L. Marzetta, O. Edfors, and F. Tufvesson, "Scaling up MIMO: Opportunities and challenges with very large arrays," *IEEE Signal Process. Mag.*, vol. 30, no. 1, pp. 40–60, Jan. 2013.
- [5] G. Hegde, Y. Cheng, and M. Pesavento, "Hybrid beamforming for large-scale MIMO systems using uplink-downlink duality," in *Proc. IEEE Int. Conf. Acoust., Speech Signal Process. (ICASSP)*, Mar. 2017, pp. 3484–3488.
- [6] R. Ye, S. He, Y. Huang, B. Jiang, and M. Su, "Power minimization hybrid precoding for millimeter wave communication systems," in *Proc. IEEE Int. Conf. Commun. Syst. (ICCS)*, Dec. 2016, pp. 1–6.
- [7] S. Malla and G. Abreu, "Transmission strategies in multi-user millimeter wave systems," in *Proc. Int. Symp. Wireless Commun. Syst. (ISWCS)*, Aug. 2017, pp. 54–59.
- [8] S. Malla and G. Abreu, "Transmit power minimization in multi-user millimeter wave systems," in *Proc. Int. Symp. Wireless Commun. Syst. (ISWCS)*, Sep. 2016, pp. 409–413.
- [9] E. G. Larsson, O. Edfors, F. Tufvesson, and T. L. Marzetta, "Massive MIMO for next generation wireless systems," *IEEE Commun. Mag.*, vol. 52, no. 2, pp. 186–195, Feb. 2014.
- [10] J. Zhang, Y. Huang, J. Wang, and L. Yang, "Hybrid precoding for wideband millimeter-wave systems with finite resolution phase shifters," *IEEE Trans. Veh. Technol.*, vol. 67, no. 11, pp. 11285–11290, Nov. 2018.
- [11] A. N. Uwaechia and N. M. Mahyuddin, "A comprehensive survey on millimeter wave communications for fifth-generation wireless networks: Feasibility and challenges," *IEEE Access*, vol. 8, pp. 62367–62414, 2020.
- [12] M. Xiao, S. Mumtaz, Y. Huang, L. Dai, Y. Li, M. Matthaiou, G. K. Karagiannidis, E. Björnson, K. Yang, and I. G. Chih-Lin, "Millimeter wave communications for future mobile networks," *IEEE J. Sel. Areas Commun.*, vol. 35, no. 9, pp. 1909–1935, Sep. 2017.
- [13] I. A. Hemadeh, K. Satyanarayana, M. El-Hajjar, and L. Hanzo, "Millimeter-wave communications: Physical channel models, design considerations, antenna constructions, and link-budget," *IEEE Commun. Surveys Tuts.*, vol. 20, no. 2, pp. 870–913, 2nd Quart., 2018.
- [14] S. Sun, T. S. Rappaport, R. W. Heath, Jr., A. Nix, and S. Rangan, "MIMO for millimeter-wave wireless communications: Beamforming, spatial multiplexing, or both?" *IEEE Commun. Mag.*, vol. 52, no. 12, pp. 110–121, Dec. 2014.
- [15] S. Stein Ioushua and Y. C. Eldar, "A family of hybrid analog-digital beamforming methods for massive MIMO systems," *IEEE Trans. Signal Process.*, vol. 67, no. 12, pp. 3243–3257, Jun. 2019.
- [16] W. Huang, Q. Si, and M. Jin, "Alternating optimization based low complexity hybrid precoding in millimeter wave MIMO systems," *IEEE Commun. Lett.*, vol. 24, no. 3, pp. 635–638, Mar. 2020.
- [17] Z. Xiao, P. Xia, and X.-G. Xia, "Codebook design for millimeter-wave channel estimation with hybrid precoding structure," *IEEE Trans. Wireless Commun.*, vol. 16, no. 1, pp. 141–153, Jan. 2017.
- [18] T. Peken, S. Adiga, R. Tandon, and T. Bose, "Deep learning for SVD and hybrid beamforming," *IEEE Trans. Wireless Commun.*, vol. 19, no. 10, pp. 6621–6642, Oct. 2020.
- [19] C.-C. Hu and C.-W. Hsu, "Efficient adaptive subarrays in millimeter-wave MIMO systems with hybrid RF/baseband precoding/combining design," *IEEE Syst. J.*, vol. 13, no. 4, pp. 3735–3746, Dec. 2019.
- [20] N. Li, Z. Wei, H. Yang, X. Zhang, and D. Yang, "Hybrid precoding for mmWave massive MIMO systems with partially connected structure," *IEEE Access*, vol. 5, pp. 15142–15151, 2017.
- [21] X. Wu, D. Liu, and F. Yin, "Hybrid beamforming for multi-user massive MIMO systems," *IEEE Trans. Commun.*, vol. 66, no. 9, pp. 3879–3891, Sep. 2018.
- [22] G. M. Zilli and W.-P. Zhu, "Constrained channel decomposition-based hybrid beamforming for mmWave massive MIMO systems," *IEEE Open J. Commun. Soc.*, vol. 1, pp. 1707–1720, 2020.
- [23] Y. Zhang, J. Du, Y. Chen, X. Li, K. M. Rabie, and R. Khkrel, "Dual-iterative hybrid beamforming design for millimeter-wave massive multi-user MIMO systems with sub-connected structure," *IEEE Trans. Veh. Technol.*, vol. 69, no. 11, pp. 13482–13496, Nov. 2020.
- [24] X. Tian, M. Li, Z. Wang, and Q. Liu, "Hybrid precoder and combiner design for secure transmission in mmWave MIMO systems," in *Proc. IEEE Global Commun. Conf. (GLOBECOM)*, Dec. 2017, pp. 1–6.
- [25] C. Chen, Y. Dong, X. Cheng, and L. Yang, "Low-resolution PSs based hybrid precoding for multiuser communication systems," *IEEE Trans. Veh. Technol.*, vol. 67, no. 7, pp. 6037–6047, Jul. 2018.
- [26] H. Li, M. Li, Q. Liu, and A. L. Swindlehurst, "Dynamic hybrid beamforming with low-resolution PSs for wideband mmWave MIMO-OFDM systems," *IEEE J. Sel. Areas Commun.*, vol. 38, no. 9, pp. 2168–2181, Sep. 2020.
- [27] A. Alkhateeb and R. W. Heath, Jr., "Frequency selective hybrid precoding for limited feedback millimeter wave systems," *IEEE Trans. Commun.*, vol. 64, no. 5, pp. 1801–1818, May 2016.
- [28] T. Mir, U. Abbasi, R. Ali, S. M. Hussain, and U. Mir, "Joint hybrid precoder and combiner for wideband millimeter-wave massive MIMO systems," *IEEE Access*, vol. 8, pp. 196375–196385, 2020.
- [29] J. P. González-Coma, J. Rodríguez-Fernández, N. González-Prelcic, L. Castedo, and R. W. Heath, Jr., "Channel estimation and hybrid precoding for frequency selective multiuser mmWave MIMO systems," *IEEE J. Sel. Topics Signal Process.*, vol. 12, no. 2, pp. 353–367, May 2018.
- [30] Y. Chen, D. Chen, T. Jiang, and L. Hanzo, "Channel-covariance and angle-of-departure aided hybrid precoding for wideband multiuser millimeter wave MIMO systems," *IEEE Trans. Commun.*, vol. 67, no. 12, pp. 8315–8328, Dec. 2019.

- [31] S. Gherekhloo, K. Ardah, and M. Haardt, "Hybrid beamforming design for downlink MU-MIMO-OFDM millimeter-wave systems," in *Proc. IEEE 11th Sensor Array Multichannel Signal Process. Workshop (SAM)*, Jun. 2020, pp. 1–5.
- [32] J. Zhang, X. Yu, and K. B. Letaief, "Hybrid beamforming for 5G and beyond millimeter-wave systems: A holistic view," *IEEE Open J. Commun. Soc.*, vol. 1, pp. 77–91, 2020.
- [33] X. Yu, J. Shen, J. Zhang, and K. B. Letaief, "Alternating minimization algorithms for hybrid precoding in millimeter wave MIMO systems," *IEEE J. Sel. Topics Signal Process.*, vol. 10, no. 3, pp. 485–500, Feb. 2016.
- [34] W. Ni and X. Dong, "Hybrid block diagonalization for massive multiuser MIMO systems," *IEEE Trans. Commun.*, vol. 64, no. 1, pp. 201–211, Jan. 2016.
- [35] C. Hu, J. Liu, X. Liao, Y. Liu, and J. Wang, "A novel equivalent baseband channel of hybrid beamforming in massive multiuser MIMO systems," *IEEE Commun. Lett.*, vol. 22, no. 4, pp. 764–767, Apr. 2018.
- [36] Y. Niu, Z. Feng, M. Chen, Y. Li, Z. Zhong, and B. Ai, "Low complexity and robust codebook-based analog beamforming for millimeter wave MIMO systems," *IEEE Access*, vol. 5, pp. 19824–19834, 2017.
- [37] D. Zhang, Y. Wang, X. Li, and W. Xiang, "Hybrid beamforming for downlink multiuser millimeter wave MIMO-OFDM systems," *IET Commun.*, vol. 13, no. 11, pp. 1557–1564, Jul. 2019.
- [38] X. Zhao, T. Lin, T. Hui, and Y. Zhu, "Hybrid beamforming for multiuser millimeter wave MIMO-OFDM Systems," in *Proc. IEEE 6th Int. Conf. Comput. Commun. (ICCC)*, Dec. 2020, pp. 618–622.
- [39] L. Qianrui, "Hybrid precoding for wideband multi-user MIMO millimeter wave system," in *Proc. IEEE Wireless Commun. Netw. Conf. (WCNC)*, Apr. 2019, pp. 1–6.
- [40] X. Sun and C. Qi, "Codeword selection and hybrid precoding for multiuser millimeter-wave massive MIMO systems," *IEEE Commun. Lett.*, vol. 23, no. 3, pp. 386–389, Feb. 2019.
- [41] B. Dutta, R. Budhiraja, and R. D. Koilpillai, "Low-complexity subspace-based multi-user hybrid precoding," *IEEE Commun. Lett.*, vol. 23, no. 2, pp. 222–225, Feb. 2019.
- [42] X. Yu, J. Zhang, and K. B. Letaief, "Alternating minimization for hybrid precoding in multiuser OFDM mmWave systems," in *Proc. 50th Asilomar Conf. Signals, Syst. Comput.*, Nov. 2016, pp. 281–285.
- [43] O. El Ayach, S. Rajagopal, S. Abu-Surra, Z. Pi, and R. W. Heath, Jr., "Spatially sparse precoding in millimeter wave MIMO systems," *IEEE Trans. Wireless Commun.*, vol. 13, no. 3, pp. 1499–1513, Mar. 2014.
- [44] M. R. Akdeniz, Y. Liu, M. K. Samimi MK, S. Sun, S. Rangan, T. S. Rappaport, and E. Erkip, "Millimeter wave channel modeling and cellular capacity evaluation," *IEEE J. Sel. Areas Commun.*, vol. 32, no. 6, pp. 1164–1179, Jun. 2014.
- [45] Q. H. Spencer, A. L. Swindlehurst, and M. Haardt, "Zero-forcing methods for downlink spatial multiplexing in multiuser MIMO channels," *IEEE Trans. Signal Process.*, vol. 52, no. 2, pp. 461–471, Feb. 2004.
- [46] E. Chu, J. Yoon, and B. Jung, "A novel link-to-system mapping technique based on machine learning for 5G/IoT wireless networks," *Sensors*, vol. 19, no. 5, p. 1196, Mar. 2019.
- [47] *3rd Generation Partnership Project; Technical Specification Group Radio Access Network; NR; Multiplexing and Channel Coding (Release 16)*, document TS 38.212 V16.3.0, 3GPP, Sep. 2020. [Online]. Available: <http://www.3gpp.org>
- [48] G. H. Golub and C. F. Van Loan, *Matrix Computations*, 4th ed. Baltimore, MD, USA: The Johns Hopkins Univ. Press, 2013.
- [49] *3rd Generation Partnership Project; Technical Specification Group Radio Access Network; Study on Channel Model for Frequency Spectrum Above 6 GHz (Release 15)*, document TR 38.900 V15.0.0, 3GPP, Jun. 2018. [Online]. Available: <http://www.3gpp.org>
- [50] *3rd Generation Partnership Project; Technical Specification Group Radio Access Network; Study on Channel Model for Frequencies From 0.5 to 100 GHz (Release 16)*, document TR 38.901 V16.1.0, 3GPP, Dec. 2019. [Online]. Available: <http://www.3gpp.org>



BO-YAN CHEN received the B.S. degree in electrical engineering from National United University, Miaoli, Taiwan, in 2019, and the M.S. degree in communication engineering from National Central University, Taoyuan, Taiwan, in 2021. Since 2021, he has been engaged in 5G physical layer performance verification-related work with MediaTek Inc., Hsinchu, Taiwan. His current research interests include baseband technologies for 5G and B5G wireless communications, with emphasis on beamforming algorithms and multicarrier transmission schemes.



YUNG-FANG CHEN (Member, IEEE) received the B.S. degree in computer science and information engineering from National Taiwan University, Taipei, Taiwan, in 1990, the M.S. degree in electrical engineering from the University of Maryland, College Park, in 1994, and the Ph.D. degree in electrical engineering from Purdue University, West Lafayette, IN, USA, in 1998. From 1998 to 2000, he was at Lucent Technologies, Whippany, NJ, USA, where he worked with the CDMA Radio Technology Performance Group. Since 2000, he has been the Faculty Member with the Department of Communication Engineering, National Central University, Taoyuan, Taiwan, where he is currently a Professor. From 2017 to 2020, he was the Chairperson of the Department of Communication Engineering, National Central University. Since 2021, he has been the Vice Dean of the College of Electrical Engineering and Computer Science. His research interests include resource management algorithm designs for communication systems and signal processing algorithm designs for wireless communication systems.



SHU-MING TSENG (Member, IEEE) received the Ph.D. degree in electrical engineering from Purdue University, West Lafayette, IN, USA, in 1999. Since 2001, he has been with the Department of Electronic Engineering, National Taipei University of Technology, Taipei, Taiwan, where he has been a Professor, since 2007. He is the author of 58 SCI journal articles, including 17 in IEEE. His research interests include AI, B5G, radio resource allocation, cross layer design, video temporal segmentation, network performance evaluation, and optical sensors. He is a TPC member of IEEE International Wireless Communications and Mobile Computing Conference (IWCMC) 2022 Low Power IoT Symposium. He was a TPC Co-Chair of IEEE 2021 30th Wireless and Optical Communications Conference (WOCC 2021). He is the Editor of *KSII Transactions on Internet and Information Systems*.

...