

## RESEARCH ARTICLE

# Research on Influence of Damping on the Vibration Noise of Transformer

LIHUA ZHU<sup>1,2</sup>, JIANYING HAO<sup>1</sup>, AND LAN LU<sup>1</sup> <sup>1</sup>Department of Electrical Engineering, Tiangong University, Tianjin 300387, China<sup>2</sup>School of Electrical Engineering and Automation, Tianjin University of Technology, Tianjin 300382, China

Corresponding author: Lihua Zhu (zhulihua@email.tjut.edu.cn)

This work was supported in part by the National Natural Science Foundation of China under Grant 92066206.

**ABSTRACT** To improve the transformer vibration analysis accuracy, a numerical vibration model of transformer, including the damping effect, is proposed in the paper. According to power transformer structure, the Rayleigh damping model is used to indicate the transformer damping effect. The damping coefficients can be got by analyzing and testing the transformer structure. The modal measurement system of the prototype is constructed and tested to improve and verify the modal analysis method, which can be used to analyze the engineering power transformer that the modal measurement should not be achieved. According to the Rayleigh damping parameters, the vibration and noise of damped and undamped transformers are calculated respectively. Then the effect of the damping on the vibration and noise can be obtained. At last, the vibration and noise of the transformer were tested and compared with the analytic results. Comprehensive analysis shows that the analysis results considering damping can be improved, and are closer to the measured results.

**INDEX TERMS** Damping effect, vibration noise, transformer, modal analysis, Rayleigh damping.

## I. INTRODUCTION

It is well known that transformers play a vital role in power energy transmission. The vibration and noise of the transformer will affect not only the normal operation and service life of the transformer, but also the normal life of human beings. In recent years, reducing audible noise from transformer core has become the key to high-quality living environment. Therefore, the vibration and noise of transformers has attracted extensive attention, which becomes one of the indicators for evaluating performance of transformer. Thus, it is of great significance to study the vibration and noise of transformer [1], [2], [3].

The main source of transformer noise is its body vibration and cooler. The vibration and noise of the transformer is related to the transformer load, silicon steel sheet material, core structure, magnetic flux density and other factors [4]. In recent years, in order to better design low-noise

transformers, the academic community has paid more and more attention to improving the accuracy of transformer vibration and noise calculation [5], [6]. By combining the electromagnetic field theory with the elastic theory, a mathematical model of transformer electromagnetic vibration is established [7], [8]. Reference [9] studied the magneto-mechanical effects of core transformers with different structures, and experiments verified that transformers have high vibration strength. [10], [11] established the electromagnetic mechanical vibration coupling mathematical model considering the magnetostrictive characteristics of the transformer, and simulates the vibration and noise of the transformer. Reference [12] proposed to obtain the quantitative relationship between the magnetostriction characteristics of the core reactor and the noise by systematically evaluating the noise and vibration shape of the simple small transformer core. [13] obtained the relationship between magnetostriction of grain oriented electrical steel (GOES) coils and no-load noise of power transformer (PT) by experiments. [14] analyzed the winding electromagnetic vibration of AIHS converter

The associate editor coordinating the review of this manuscript and approving it for publication was Yingxiang Liu .

transformer in HVDC transmission system. It is revealed that the AIHS converter transformer and its corresponding filter can improve the performance by reducing the winding vibration in real HVDC applications. The existing researches on transformer vibration and noise mainly focus on the magnetic characteristics of transformer and the analysis method of vibration signal, but ignore the damping effect of transformer. Damping, as one of the characteristics reflecting energy dissipation in vibration process, is an important factor affecting the vibration response of structure. In order to further accurate numerical model of transformer electromagnetic vibration, it is of great significance to consider damping effect.

In order to improve the accuracy of transformer vibration analysis, a numerical model of transformer vibration considering damping effect is proposed in this paper. Based on the model of SGB-10KVA three-phase transformer, the modal measurement system of the prototype is constructed and tested. According to the test results, the modal analysis method is improved and verified, which can be used to analyze the engineering power transformer whose modal measurement cannot be realized. In addition, the damping parameters are calculated according to the modal measurement results, and the vibration and noise of the transformer with and without damping effect are calculated and analyzed. Finally, the vibration and noise of the transformer are tested and verified.

## II. MODAL DAMPING SELECTION

Damping, as one of the dynamic properties reflecting the energy dissipation during structural vibration, is different from other dynamic properties such as structural mass and stiffness that can be described directly and accurately, and usually needs to be abstracted into a mathematical model in the calculation. Rayleigh, Caughey and Clough have proposed models for the calculation of damping such as Rayleigh damping, Corsi damping and Clough damping respectively.

Rayleigh damping is usually used to approximate the damping effect of a structure with equivalent single damping characteristics. The main damping coefficients are calculated as:

$$[C] = \alpha[M] + \beta[K] \quad (1)$$

where  $[C]$  is the damping matrix,  $[M]$  is the mass matrix,  $[K]$  is the stiffness matrix, and  $\alpha$  and  $\beta$  are the coefficients of the mass and stiffness matrices respectively.

Using the orthogonality of the damping array about the vibration pattern, the vibration pattern of the structure  $[\phi]$  is related to the mass matrix and the stiffness matrix as follows:

$$[\phi]^T [M] [\phi] = [I]$$

$$[\phi]^T [K] [\phi] = \begin{bmatrix} \omega_1^2 & & & & \\ & \omega_2^2 & & & \\ & & \dots & & \\ & & & \omega_{n-1}^2 & \\ & & & & \omega_n^2 \end{bmatrix} \quad (2)$$

The expressions of transformer mass matrix and stiffness matrix coefficients are obtained by numerical calculation:

$$\alpha = \frac{2[\sum (\xi_i/\omega_i) \sum \omega_i^2 - n \sum \omega_i \xi_i]}{\sum (1/\omega_i^2) \sum \omega_i^2 - n^2} \quad (3)$$

$$\beta = \frac{2[\sum (1/\omega_i^2) \sum \omega_i \xi_i - n \sum (\xi_i/\omega_i)]}{\sum (1/\omega_i^2) \sum \omega_i^2 - n^2} \quad (4)$$

## III. THEORETICAL ANALYSIS OF TRANSFORMER VIBRATION NOISE

Transformer vibration noise mainly comes from noise caused by core vibration, that is, magnetostrictive effect of core silicon steel sheet and electromagnetic attraction caused by magnetic leakage between the joint of silicon steel sheet and disk. In addition, when transformer is running, winding current will generate magnetic leakage in space. Winding under alternating magnetic field will be affected by Lorentz force and cause winding vibration and noise [14].

Damping, as one of the characteristics of energy dissipation in vibration process, is also an important factor affecting the vibration response of transformer.

Proceed from vibration analysis, this paper comprehensively interprets the vibration and noise of the transformer through modal analysis, magnetic-mechanical coupling analysis and acoustic field analysis of the prototype transformer.

### A. MODAL THEORY ANALYSIS

Modal analysis is the process of replacing the original finite element node coordinates with vibration coordinates. The frequency response function of a given input and output position is expressed by modal parameters:

$$h_{ij}(j\omega) = \sum_{k=1}^m \left( \frac{q_k u_{ik} u_{jk}}{j\omega - p_k} + \frac{q_k^* u_{ik}^* u_{jk}^*}{j\omega - p_k^*} \right) \quad (5)$$

In this paper, the motion equation of the prototype transformer's N-degree-of-freedom system is simplified into a finite element elastic system with mass, elasticity and damping in the vibration coordinate system, and its motion equation is shown in (6):

$$[M]\{X(t)\} + [C]\{X(t)\} + [K]\{X(t)\} = \{F(t)\} \quad (6)$$

Take the special solution:

$$x(t) = x \sin \omega t$$

Then:

$$([K] - \omega^2[M])x = f' \quad (7)$$

Draw into formula:

$$Z(\omega) = ([K] - \omega^2[M]) \quad (8)$$

where  $Z(\omega)$  is the dynamic stiffness equation of the system and is invertible, with the inverse matrix,  $H(\omega)$  is called

the displacement frequency response function matrix of the system:

$$H(\omega) = Z^{-1}(\omega) = ([K] - \omega^2[M])^{-1} \quad (9)$$

Solving the generalised eigenvalue equations for the system matrices  $K$  and  $M$ :

$$([K] - \omega^2[M])\varphi = 0 \quad (10)$$

Solution of (10)  $\omega_i^2$  ( $i = 1, 2, 3, \dots, n$ ) called the  $i$ -th eigenvalue.  $\omega_i$  ( $i = 1, 2, 3, \dots, n$ ) is called the  $i$ -th order intrinsic circular frequency. From (10), it can be seen that the intrinsic circular frequency is only related to the stiffness matrix  $[K]$  and the mass matrix  $[M]$ . The relationship between the intrinsic frequency  $f_i$  and the intrinsic circular frequency is

$$f_i = \frac{\omega_i}{2\pi} \quad (11)$$

Satisfying (10) corresponds to  $\omega_i$  the  $i$ -th feature vector  $\{\varphi_i\}$ . It is called the  $i$ -th-order intrinsic modal or modal, or simply the  $i$ -order modal.

### B. THEORETICAL ANALYSIS OF MAGNEO-MECHANICAL COUPLING

The vibration of transformer body is mainly periodic vibration caused by magnetostriction of silicon steel sheet of iron core, that is, when ferromagnetic material is in a periodically changing magnetic field environment, the magnetostriction effect of material will also periodically change with the magnetic field. Macroscopically, it is manifested as periodic elongation and shortening of material size, thus forming periodic vibration related to magnetic field frequency. Because magnetostriction changes twice in a period of magnetic field change, the frequency of the main vibration of electromagnetic vibration is usually twice that of the excitation frequency. As the excitation frequency is power frequency, the noise characteristics of core vibration caused by magnetostriction effect are also based on 100Hz.

In addition to magnetostrictive effect, there are also vibration caused by electromagnetic attraction between joints and lamination and winding caused by leakage field. Vibration is a coupling problem of circuit, magnetic field and structure field.

In the magnetic field, the governing equation for the magnetic vector is

$$\nabla \times (\mu_0^{-1}\mu_r^{-1}\nabla \times \mathbf{A}) = \mathbf{J} \quad (12)$$

where  $A$  is the magnetic vector potential,  $J$  is the current density,  $\mu_0$  indicates vacuum permeability,  $\mu_r$  Indicates the relative magnetic permeability of the material medium.

The relationship between the magnetic induction strength  $B$  and the strength of the magnetic field can be shown to be

related to the current density  $J$  by

$$\mathbf{B} = \mu_0\mu_r\mathbf{H} = \nabla \times \mathbf{A} \quad (13)$$

In the structural force field, the relationship between stress and strain is

$$\sigma = \varepsilon D \quad (14)$$

During the operation of a power transformer, the transformer produces electromagnetic vibration due to the interaction of electromagnetic fields, among which the main force is the Maxwell force  $F_{vmax}$  of the core and the magnetostrictive force  $F_{vms}$ , and the Lorentz force  $F_l$  generated by the windings. The electromagnetic force is calculated according to (15), and the obtained results are analyzed in combination with solid mechanics, so as to realize the magnetic-mechanical coupling:

$$\begin{aligned} \mathbf{F} &= \mathbf{F}_{vmax} + \mathbf{F}_{vms} + \mathbf{F}_l \\ &= \int_S \mathbf{T}dS + \int_S \sigma_{vms}dS + \int_V \mathbf{J} \times \mathbf{B}dV \end{aligned} \quad (15)$$

Among them:

$$\sigma_{vms} = D\varepsilon_{vms}$$

where  $T$  represents Maxwell stress tensor;  $\sigma_{vms}$  magnetostrictive stress;  $D$  represents elastic tensor, which can be obtained from Young's modulus and Poisson's ratio of silicon steel;  $\varepsilon_{vms}$  is the magnetostrictive strain tensor, which is obtained by interpolating the measure  $B - \lambda_{pp}$  curve;  $F$  is the volume force in the structural field.

The node vibration equation is:

$$\mathbf{M} \frac{d^2\mathbf{u}}{dt^2} + \mathbf{C} \frac{d\mathbf{u}}{dt} + \mathbf{K}\mathbf{u} = \mathbf{F} \quad (16)$$

where  $M$  is the mass matrix,  $C$  is the damping matrix,  $K$  is the stiffness matrix.

Combined with the virtual work displacement method, the finite element method is used to discretize the solution element, and all the subdivision elements are collected. The magnetic mechanical coupling model can be written as follows:

$$\mathbf{S}\mathbf{A} = \mathbf{J} \quad (17)$$

$$\mathbf{M}\ddot{\mathbf{u}} + \mathbf{C}\dot{\mathbf{u}} + \mathbf{K}\mathbf{u} = \mathbf{F} \quad (18)$$

where  $S$  is the electromagnetic matrix;  $u$  is the displacement to be determined;  $A$  is the magnetic vector potential to be found. When the damping effect is not taken into account, the damping term in the vibration equation of the structure is 0.

### C. SOUND FIELD ANALYSIS

Transformer vibration to produce sound waves, is essentially a silicon steel sheet in the micro-element movement to produce a certain displacement, which is reflected in the transmission of waves, vibration displacement as an intermediate

amount, combined with solid mechanics with the acoustic propagation control equation can be expressed in the acoustic transmission process (19):

$$\eta \nabla^2 \mathbf{u} + (\eta + \lambda) \nabla \nabla \cdot \mathbf{u} = \rho \frac{\partial^2 \mathbf{u}}{\partial t^2} \quad (19)$$

where  $\rho$  is the density of the medium,  $\eta$  is shear modulus,  $\lambda$  is the elasticity constant. In order to obtain the distribution of the sound field around the transformer, the sound pressure level energy of the resulting waveform needs to be calculated to determine the noise level distribution.

Transformer-generated acoustic waves propagate through air, and the conventional finite difference method combined with the immersed boundary method is used to derive the acoustic propagation control equations for acoustic waves containing complex boundaries and moving boundaries:

$$\frac{\partial \rho}{\partial t} + \nabla \cdot (\rho \mathbf{V}) = 0 \quad (20)$$

In the formula,  $\mathbf{V} = (a, b, c)$  is the vector form of the proton velocity. The sound wave propagation process should satisfy the continuity equation, momentum conservation equation and energy conservation equation of the sound wave, and the above equations can be solved with (19) and (20) to find the sound field propagation equation.

Based on the results of the pre-sequential magnetic field and solid mechanics calculations, the energy  $W_m$  at any point  $m$  of the sound energy around the power transformer is obtained according to (21):

$$\begin{aligned} W_m &= \rho c \kappa_n \oint_S v_i^2 dS_c = \rho_0 c_0 \kappa_n \sum_n v_{i,k}^2 S_{c,k} \cos \theta_m \\ &= \rho_0 c_0 \kappa_n \sum_n (\partial \mathbf{u}_{n,k} / \partial t)^2 S_{c,k} \cos \theta_m \end{aligned} \quad (21)$$

where  $\rho_0 c_0$  is the characteristic impedance of the air medium;  $\kappa_n$  denotes the sound radiation coefficient on the  $n$ th side;  $v_i$  denotes the root mean square velocity of the vibration perpendicular to the contact surface of the air medium;  $S_{c,k}$  is the area of the intersection of the power transformer surface unit  $k$  and the surrounding medium,  $\mathbf{u}_{n,k}$  is the displacement of the surface cell  $k$  on the  $n$ th side,  $\cos \theta_m$  indicates surface unit  $dS_{c,k}$  the angle between the two and the analysis point  $m$ .

Using the formula (20) the sound pressure level in the sound field around the transformer can be calculated as follows:

$$L_{p_m} = 10 \lg (W_m / W_0) - \lg R_m - Q \quad (22)$$

where  $W_0 = 10^{-12} W$ ,  $W$  is the reference reference energy,  $R_m$  is the actual distance between measuring point  $m$  and transformer core;  $Q$  is the degree of freedom coefficient of the surrounding sound field, where the value of the free sound field is 11, and the value of the semi-free sound field is 8.

TABLE 1. Material parameters for transformer components.

Components	Modulus of elasticity (GPa)	Poisson's ratio	Density (kg·m <sup>-3</sup> )
Core	205	0.29	7650
Coil	126	0.34	8940
Clamp	200	0.3	7850

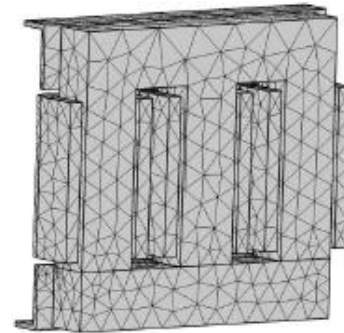

FIGURE 1. 1/2 Schematic diagram of transformer model grid generation.

#### IV. U EXPERIMENTAL ANALYSIS OF TRANSFORMER VIBRATION

In order to verify the correctness of the above numerical calculation, the prototype transformer needs to be modeled in the software first. The model established in this paper is based on the actual size of the SGB-10kVA prototype transformer. The finite element model mainly considers the core, clamp, winding and other components of the transformer. The parameters of the prototype are shown in the Table 1:

Due to the symmetry of the structure of the prototype transformer, the whole transformer model is simplified to a 1/2 model, which can simplify the model and improve the calculation efficiency. Then mesh them, including 7454 domain elements, 3839 boundary elements and 944 edge elements. The results are shown in Figure 1.

Since the magnetic properties and magnetostrictive properties are inherent properties of the material, the data of the magnetic properties and magnetostrictive properties of the silicon steel sheet when the transformer is running are brought into the model for calculation. First, the input excitation of the transformer is set by the current calculated from the no-load rated voltage provided by the prototype transformer manufacturer. In this paper, the 26A AC power supply is used as the input excitation of the transformer, and the windings are set to be uniform and multi-turn. Because the prototype works at power frequency, the frequency domain is set to 50Hz. After the designed circuit meets the operating conditions of the transformer, carry out numerical simulation of electromagnetic vibration and noise.

Through the modal experiment platform and electromagnetic vibration measurement platform, the modal parameters, electromagnetic vibration and noise of the three-phase



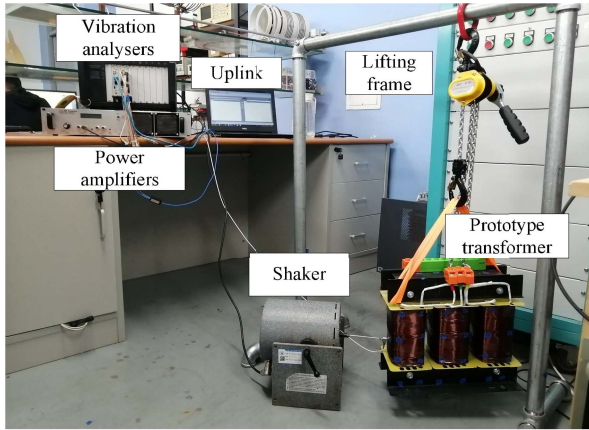

FIGURE 2. Parameters of the modal test system.

TABLE 2. Equipment composition and main parameters of the modal test system.

Equipment name	Type	Main parameters
Collection systems	AMETEK-VTI-CMX09	16Access
Analysis systems	DSP	SIMO Modules
Shaker	DC6000	Maximum sine thrust $\geq 220\text{N}\cdot\text{pk}$
Force sensors	Piezoelectric	Sensitivity 22mv/N
Three-axis acceleration sensors	Piezoelectric	Sensitivity X:5.141mv/g Y:5.077mv/g Z:5.170mv/g

transformer prototype are measured and analyzed when it is running without load.

**A. MODAL EXPERIMENTAL ANALYSIS**

The AMETEK-VTI-CMX09 signal analysis and acquisition system used in this paper was developed by AMETEK, a US company, which is capable of both modal vibration data acquisition and instant analysis of the collected data. X-MODAL software on the PC side can be imported to analyse and calculate the collected data. The system components are shown in Table 2 and the modal test system for transformer specimens is shown in Figure 2.

In order to simulate the “free-free” experimental conditions of the modal, the transformer specimens were flexibly suspended from a steel test frame by means of a less damped and less sensitive suspension rope. In order to match the experimental modal with the actual model characteristics, 60 measuring points, 12 measuring points and 84 measuring points were set up on the core, winding and complete surface of the transformer respectively. The test site is shown in Figure 3.

In this study, the modal state of the transformer under study was first calculated using analysis software. Since the first

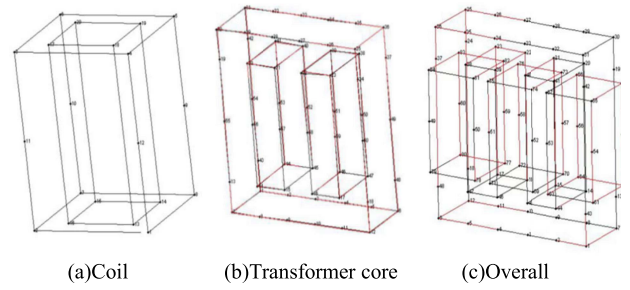

FIGURE 3. Sketch of transformer components.

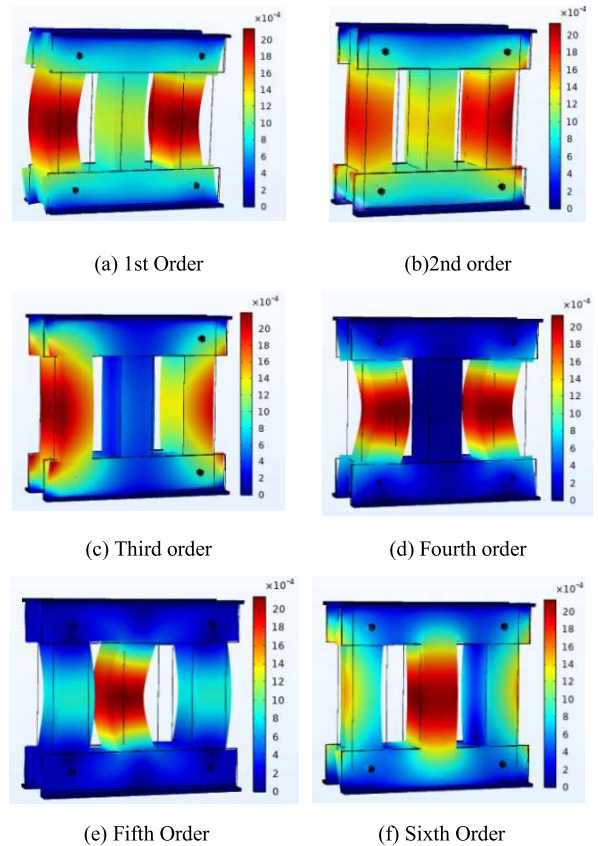

FIGURE 4. Calculated modal vibrations of the first six orders of the transformer core.

few orders of modal state have a more significant effect on the system vibration, the first six orders of modal frequency were taken as the main object of study in this paper. The first six orders of the transformer are shown in Figure 4.

Combined with the simulated experimental calculation data, after the modal test completed the data acquisition at each measurement point, the collected excitation force signal and the response signal collected by the three-way acceleration s-ensor were imported into the X-MODAL/DSP signal proces-sing system respectively, and the first six orders of the transf-ormer calculated and measured eigenfrequencies were collat-ed asshown in Table 3.

**TABLE 3.** First six order characteristic frequency table.

Modal order	complete machine (Hz)	calculate measure
modal 1	2684.3	2147.1593
modal 2	2695.0	2424.0889
modal 3	3007.8	2570.0427
modal 4	3146.2	2873.8606
modal 5	3178.4	3046.1883
modal 6	3196.0	3281.1961

From the test obtained the transformer’s intrinsic frequency, damping ratio and vibration type, the results are brought into (3) and (4) to obtain the actual damping matrix stiffness coefficient and mass coefficient. The obtained transformer stiffness coefficient is  $1.036 \times 10^{-4}$  and the mass coefficient is  $3.689 \times 10^3$ . The obtained transformer mass matrix coefficient and stiffness matrix coefficient provide data support for the subsequent vibration and noise experimental analysis.

**B. TRANSFORMER VIBRATION NOISE EXPERIMENTS AND SIMULATION ANALYSIS**

In order to determine the actual vibration noise of the transformer, we needed to carry out an experimental analysis of the prototype transformer under air. The 10kVA three-phase transformer experimental platform used in this paper consists mainly of the test prototype, an adjustable voltage three-phase AC power supply and a vibration test system. The prototype transformer is powered by the adjustable voltage three-phase AC power supply, and the excitation is applied in the transformer working winding. 50 Hz AC power is used to ensure the normal operation of the transformer, while vibration data is collected using the SQuadriga\_II. The vibration and noise data acquisition analyser SQuadriga\_II used in this experiment is a multi-functional portable system which can be collected by sensors to The SQuadriga\_II is a multifunctional portable system that can collect vibration and noise data from the prototype through sensors and store them, and then import them to the PC for analysis and processing through the frontend mode. The prototype vibration and noise test site is shown in Figure 5.

The complex vibration is decomposed into a number of resonances of different amplitudes and frequencies by the FFT transform, and the resonance amplitudes are arranged by frequency to obtain a vibration spectrum. A three-way acceleration sensor was used to measure the transformer vibration, with the X, Y and Z directions of the three-way sensor probe corresponding to the three channels of the vibration analyser in turn. The experimentally obtained vibration spectrum of the prototype is shown in Figure 6.

The electromagnetic vibration of transformer is mainly due to the periodic vibration of core caused by magnetostriction

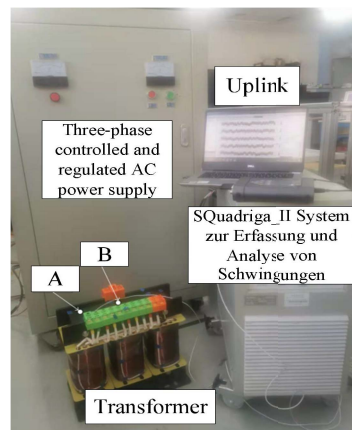

**FIGURE 5.** Field view of the prototype vibration and noise measurement experiment.

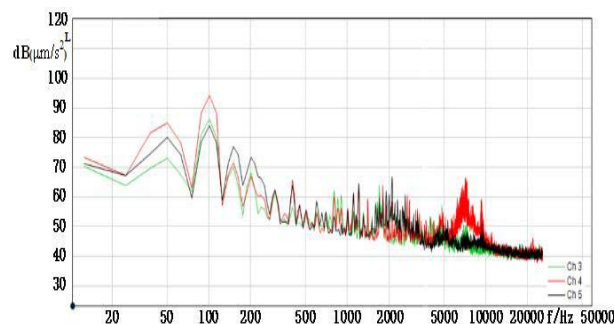

**FIGURE 6.** Vibration spectrum.

with the change of excitation frequency. By analyzing the electromagnetic vibration of a 10kVA/380V three-phase transformer, the electromagnetic vibration of transformer under different damping conditions is studied in this paper.

To reflect the influence of modal damping on vibration it is first necessary to carry out a vibration analysis of the transformer. On the basis of a correct calculation of the magnetic field, the analysis of electromagnetic vibration is started.

The specific parameters of the experimental prototype first need to be entered into the simulation software to calculate the core flux density and coil current density in the magnetic field in the transformer prototype as shown in Figure 7.

Based on the calculations obtained in the magnetic field, the magnetostrictive strain is converted into magnetostrictive stress using the stress-strain relationship of elastodynamics, which is brought into the vibration calculations as a load, resulting in the vibration of the transformer as shown in Figure 8.

This paper is based on the magneto-mechanical coupling model, which is further extended to establish an analytical model of the sound field of the prototype. The purpose of the model is to accurately calculate the magnitude of the vibration noise generated by the prototype transformer.

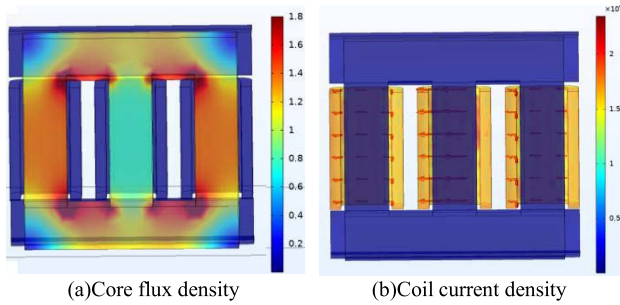

FIGURE 7. Results of the magnetic field distribution of the transformer calculation model.

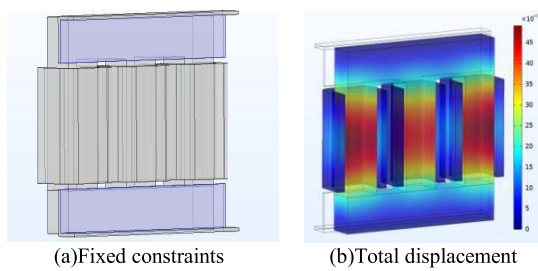

FIGURE 8. Analysis of the solid mechanics of the transformer.

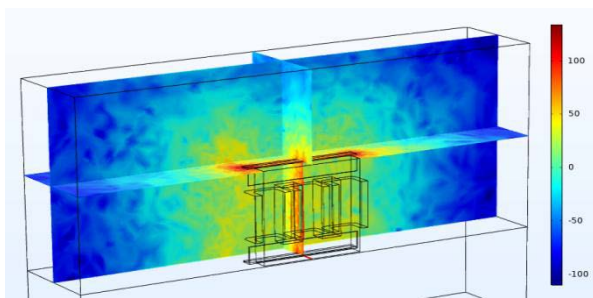

FIGURE 9. Sound field distribution of power transformers.

Figure 9 shows a schematic diagram of the transformer noise sound pressure level.

V. COMPARISON AND ANALYSIS OF RESULTS

According to the calculation results of the damping coefficients in the previous section, the calculated mass matrix coefficient  $\alpha$  and stiffness matrix coefficient  $\beta$  are brought into the finite element numerical analysis software. By modifying boundary conditions and setting solvers, the overall damping effect is considered for calculation. After the analysis and comparison, points A and B with clear vibration waveforms are selected as the main comparison points. Figure 10 shows the comparison between simulation and experiment on vibration under each condition.

From the above figure, it can be seen that the simulation value of the transformer vibration without considering damping effect is greater than the actual experimental values, and the simulation value without considering damping effect is closer to the experimental values, and the partially damped

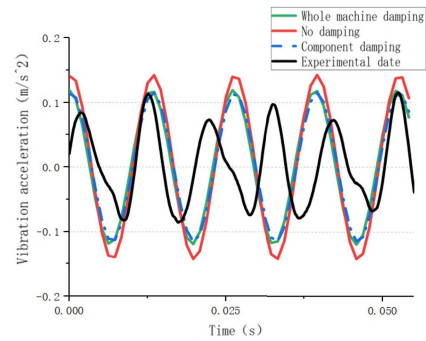

(a) A vibration comparison chart

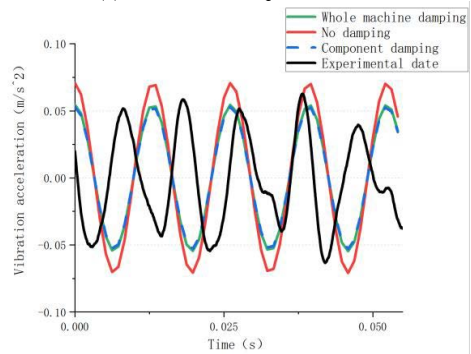

(b) B vibration comparison chart

FIGURE 10. Comparison of experimental and simulated vibrations.

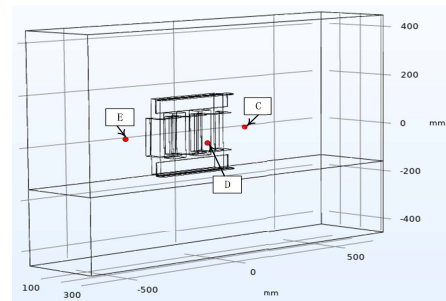

FIGURE 11. Schematic diagram of the distribution of measurement points.

line is closer to the experimental values. Therefore, it is easy to draw a conclusion that the electromagnetic vibration analysis of transformers is affected by damping effect to some extent, and considering damping effect can make the calculation of electromagnetic vibration more accurate.

In order to verify the influence of damping on transformer noise, this paper selects three points around the transformer C, D and E as reference points (as shown in Figure 11). According to the calculation of transformer noise in the previous section, the change of transformer noise after adding damping effect is analyzed. First of all, use the transformer noise model to calculate the sound pressure level distribution of undamped transformer noise and the sound pressure distribution after damping, as shown in Figure 12.



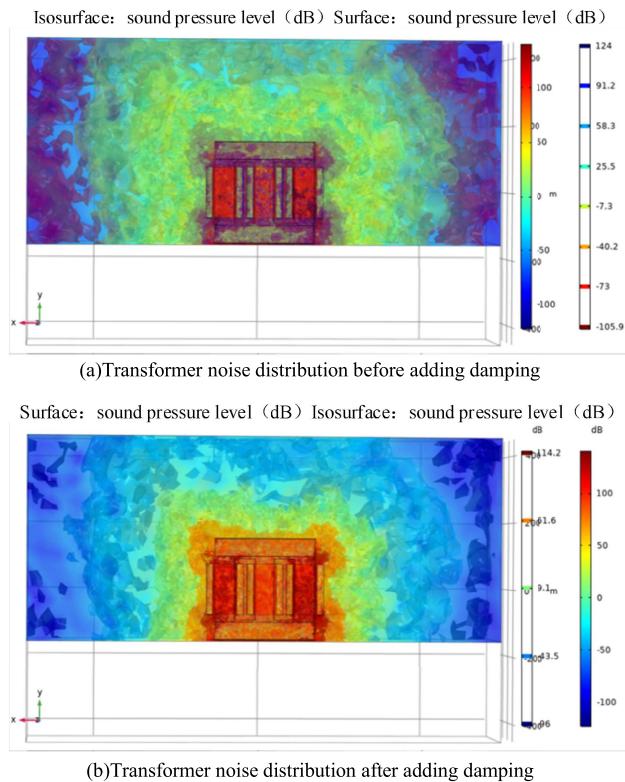

FIGURE 12. Distribution of transformer noise sound pressure levels.

TABLE 4. Noise values at measurement points.

Measuring points	Measured values (dB)	Undam-ped (dB)	Integral damping (dB)
C	32.33	40.72	32.73
D	47.17	53.95	48.26
E	40.82	48.79	41.14

From the data in the chart, it can be seen that the noise range of the transformer is 1.048 dB ~ 61.926 dB before the damping parameter is added, but it is 3.426 dB ~ 73.428 dB after the damping parameter is added. It is not difficult to draw a conclusion that the noise of the transformer will be affected by the damping in simulation calculation.

Then, through the simulation calculation of the noise model, the noise decibels in three cases are obtained, and compared with the data obtained from the noise experiment. The comparison data are shown in Table 4.

The data in the table show that the noise values of the measurement points without damping is higher than the actual measurement values, while the noise values of the measurement points with damping is lower than that without damping, and closer to the actual measurement values. This proves once again that the damping effect not only affects transformer vibration analysis, but also affects the vibration and noise analysis to some degree.

## VI. CONCLUSION

In this paper, the first six main vibration modal of the test transformer and their corresponding damping ratios and natural frequencies are quantitatively calculated by using the finite element simulation software, and the accuracy of simulations is verified by modal experiments. The mass matrix parameters and stiffness matrix parameters corresponding to the selected Rayleigh damping are calculated by using the simulation results. In addition, the results are brought into the damping module of the simulation software to participate in calculations, and the results of electromagnetic vibration and the noise distribution of the transformer are obtained. By comparing the vibration acceleration with noise sound pressure level, the following conclusions are drawn.

- 1) Under condition of transformer normal working, the vibration noise of transformer will be affected by damping effect.
- 2) The accuracy of calculation will be improved with the addition of damping effect.

In this paper, the distribution of electromagnetic vibration and noise of transformer considering damping effects is studied. These opinions play an important role in improving the calculation accuracy of transformer electromagnetic vibration and noise, accurately predicting the noise level of transformer products, and researching more effective method of vibration reduction and noise reduction.

## REFERENCES

- [1] H. Xia, K. Yang, Y. Ma, Y. Wang, and Y. Liu, "Noise reduction method for acoustic sensor arrays in underwater noise," *IEEE Sensors J.*, vol. 16, no. 24, pp. 8972–8981, Dec. 2016, doi: [10.1109/JSEN.2016.2618770](https://doi.org/10.1109/JSEN.2016.2618770).
- [2] H. Jingzhu, L. Dichen, L. Qingfen, Y. Yang, and L. Shanshan, "Electromagnetic vibration noise analysis of transformer windings and core," *IET Electr. Power Appl.*, vol. 10, no. 4, pp. 251–257, Apr. 2016.
- [3] T. Phway and A. J. Moses, "Magnetisation-induced mechanical resonance in electrical steels," *J. Magn. Magn. Mater.*, vol. 316, no. 2, pp. 468–471, 2007.
- [4] A. J. Moses, P. I. Anderson, and T. Phopongviwat, "Localized surface vibration and acoustic noise emitted from laboratory-scale transformer cores assembled from grain-oriented electrical steel," *IEEE Trans. Magn.*, vol. 52, no. 10, pp. 1–15, Oct. 2016, doi: [10.1109/TMAG.2016.2584004](https://doi.org/10.1109/TMAG.2016.2584004).
- [5] B. Zhang, N. Yan, J. Du, F. Han, and H. Wang, "A novel approach to investigate the core vibration in power transformers," *IEEE Trans. Magn.*, vol. 54, no. 11, pp. 1–4, Nov. 2018, doi: [10.1109/TMAG.2018.2839722](https://doi.org/10.1109/TMAG.2018.2839722).
- [6] L. Min, S. Li, X. Zhang, F. Zhang, Z. Sun, M. Wang, Q. Zhao, Y. Yang, and L. Ma, "The research of vibration monitoring system for transformer based on optical fiber sensing," in *Proc. IEEE 3rd Optoelectron. Global Conf. (OGC)*, Sep. 2018, pp. 126–129, doi: [10.1109/OGC.2018.8529978](https://doi.org/10.1109/OGC.2018.8529978).
- [7] Y.-H. Chang, C.-H. Hsu, H.-L. Chu, and C.-P. Tseng, "Magnetomechanical vibrations of three-phase three-leg transformer with different amorphous-cored structures," *IEEE Trans. Magn.*, vol. 47, no. 10, pp. 2780–2783, Oct. 2011, doi: [10.1109/TMAG.2011.2146242](https://doi.org/10.1109/TMAG.2011.2146242).
- [8] M. Bagheri, A. Zollanvari, and S. Nezhivenko, "Transformer Fault condition prognosis using vibration signals over cloud environment," *IEEE Access*, vol. 6, pp. 9862–9874, 2018, doi: [10.1109/ACCESS.2018.2809436](https://doi.org/10.1109/ACCESS.2018.2809436).
- [9] A. Secic, M. Krpan, and I. Kuzle, "Vibro-acoustic methods in the condition assessment of power transformers: A survey," *IEEE Access*, vol. 7, pp. 83915–83931, 2019, doi: [10.1109/ACCESS.2019.2923809](https://doi.org/10.1109/ACCESS.2019.2923809).
- [10] L. Zhu, Q. Yang, and R. Yan, "Numerical analysis of vibration due to magnetostriiction of three phase transformer core," in *Proc. 6th Int. Conf. Electromagn. Field Problems Appl.*, Jun. 2012, pp. 1–4, doi: [10.1109/ICEF.2012.6310376](https://doi.org/10.1109/ICEF.2012.6310376).



- [11] F. Yang, Z. Ren, D. Zhang, L. Li, X. Fan, and Y. Zhou, "Simulation analysis and experiment validation of vibration and noise of oil-immersed transformer," in *Proc. 22nd Int. Conf. Electr. Mach. Syst. (ICEMS)*, Aug. 2019, pp. 1–5, doi: 10.1109/ICEMS.2019.8922244.
- [12] J. Moses, P. I. Anderson, T. Phophongviwat, and S. Tabrizi, "Contribution of magnetostriction to transformer noise," in *Proc. 45th Int. Univ. Power Eng. Conf. (UPEC)*, 2010, pp. 1–5.
- [13] T. Tanzer, H. Pregartner, M. Riedenbauer, R. Labinsky, M. Witlatschil, A. Muetze, and K. Krischan, "Magnetostriction of electrical steel and its relation to the no-load noise of power transformers," *IEEE Trans. Ind. Appl.*, vol. 54, no. 5, pp. 4306–4314, Sep. 2018, doi: 10.1109/TIA.2018.2840977.
- [14] P. Shao, L. Luo, Y. Li, and C. Rehtanz, "Electromagnetic vibration analysis of the winding of a new HVDC converter transformer," *IEEE Trans. Power Del.*, vol. 27, no. 1, pp. 123–130, Jan. 2012, doi: 10.1109/TPWRD.2011.2174164.



**LIHUA ZHU** was born in March 1984. She received the bachelor's degree in electrical engineering and automation from the Hunan Institute of Engineering, in 2007, and the master's and Ph.D. degrees in electrical engineering from the Hebei University of Technology, in 2010 and 2013, respectively.

She joined Tiangong University as a Lecturer, in 2013, where she won the title of an Associate Professor, in 2016. She served as a one-year Seconded Staff of the China Science and Technology Exchange Center, in 2017. She won the title of a Professor with Tiangong University, in 2020. She studied as a Visiting Scholar at Zhongbei National University, South Korea, in 2018. In 2021, she entered Tiangong University as a Professor to carry out teaching and scientific research related work. In 2018, she has published "Core Loss Calculation Based on Finite-Element Method With Jiles–Atherton Dynamic Hysteresis Model" in *IEEE TRANSACTIONS ON MAGNETIC*. In 2020, she has published "An Improved Magnetostriction Model for Electrical Steel Sheet Based on Jiles–Atherton Model" in *IEEE TRANSACTIONS ON MAGNETIC*. In May 2021, she has published "New Structure of a Gap-Reactor to Reduce Electromagnetic Vibrations" in the *Journal of Electrical Engineering & Technology*, and other papers. Her research interests include numerical analysis of engineering electromagnetic field, vibration and noise reduction technology of electromagnetic energy equipment, and radio energy transmission technology.

Prof. Zhu is also a member of the International Society for Computational Electromagnetics (ICS), the Deputy Secretary-General of the Electrical Theory and New Technology Committee of the China Electrotechnical Society, and the Deputy Secretary-General of the Tianjin Society of Electrical Engineering. The awards and honors, she has won include Hebei Provincial Excellent Doctoral Dissertation, Tianjin "131" Talents Backbone and Tianjin Young, and Middle-Aged Backbone Innovative Talents Training Program.



**JIANYING HAO** was born in August 1996. He received the bachelor's degree in electrical engineering and automation from the Hebei Normal University of Science and Technology, in 2019. He is currently pursuing the master's degree in electrical engineering with Tiangong University.

His research interests include numerical analysis of engineering electromagnetic fields, vibration reduction, and reduction of electromagnetic energy equipment noise technology. During his master's degree, he won a Freshman Scholarship and a Third-Class Scholarship, in 2020. In April 2021, he has published an invention patent "Method for Active Noise Reduction of Electrical Equipment," which has been disclosed. His research interests include numerical analysis of engineering electromagnetic fields and multi-physics coupling.



**LAN LU** was born in November 1995. She received the bachelor's degree in electrical engineering and automation from the School of Science and Technology, North China Electric Power University, in 2018. She is currently pursuing the master's degree in electrical engineering with Tiangong University. Her research interests include numerical analysis of engineering electromagnetic field and vibration and noise reduction technology of electromagnetic energy equipment.

During her master's degree, she won a Freshman Scholarship and a Third-Class Scholarship. In September 2021, she published a utility model patent "A Phononic Crystal Sound Isolator for Noise Reduction of Electrical Equipment." At present, the electromagnetic vibration and noise of engineering electrical equipment are mainly studied and studied.

...