

Received 17 June 2022, accepted 20 July 2022, date of publication 5 August 2022, date of current version 18 August 2022.

Digital Object Identifier 10.1109/ACCESS.2022.3196784

RESEARCH ARTICLE

A Deep Learning Model to Predict Student Learning Outcomes in LMS Using CNN and LSTM

ABDULAZIZ SALAMAH ALJALOUD¹, DIAA MOHAMMED ULIYAN¹, ADEL ALKHALIL¹,
MAGDY ABD ELRHMAN^{2,3}, AZIZAH FHAD MOHAMMED ALOGALI^{4,5},
YASER MOHAMMED ALTAMEEMI⁶, MOHAMMED ALTAMIMI¹,
AND PAUL KWAN⁷, (Senior Member, IEEE)

¹Department of Information and Computer Science, College of Computer Science and Engineering, University of Ha'il, Ha'il 81481, Saudi Arabia

²Foundations of Education Department, Community College/Education College, University of Ha'il, Ha'il 81481, Saudi Arabia

³New Valley University, 1064188, Egypt

⁴Department of Educational Leadership, University of Rochester, Rochester, NY 14627, USA

⁵The University of Akron, Akron, OH 44325, USA

⁶Department of English, College of Arts and Literature, University of Ha'il, Ha'il 81481, Saudi Arabia

⁷School of IT and Engineering, Melbourne Institute of Technology, Melbourne, VIC 3000, Australia

Corresponding author: Diaa Mohammed Uliyan (d.ulyan@uoh.edu.sa)

This work was supported by the University of Ha'il, Ha'il, Saudi Arabia, under Grant. This work was supported by the University of Ha'il, Ha'il, Saudi Arabia, under Grant.

ABSTRACT Learning Management Systems (LMSs) are increasingly utilized for the administration, tracking, and reporting of educational activities. One such widely used LMS in higher education institutions around the world is Blackboard. This is due to its capabilities of aligning items of learning content, student-student and student-teacher interactions, and assessment tasks to specified goals and student learning outcomes. This study aimed to determine how certain Key Performance Indicators (KPIs) based on student interactions with Blackboard helped to forecast the learning outcomes of students. A mixed-methods study design was used which included analysis of four deep learning models for predicting student performance. Data were collected from reports on seven general preparation courses. They were analyzed using a documentary analysis approach to establish possible predictive KPIs associated with the electronic Blackboard report. Correlational analyses were performed to examine the extent to which these factors are linearly correlated with the performance indicators of students. Results indicated that a predictive model which combined convolutional neural networks and long short-term memory (CNN-LSTM) was the optimal method among the four models tested. The main conclusion drawn from this finding is that the combined CNN-LSTM approach may lead to interventions that optimize and expand use of the Blackboard LMS in universities.

INDEX TERMS Learning management systems, student prediction, deep learning, CNN, LSTM.

I. INTRODUCTION

A Learning Management System (LMS) is an application of purposefully selected software that supports the learning process in higher education institutions. It acts as an automated system for the administration, tracking, and reporting of educational activities and learning outcomes [1]. LMSs are designed and implemented to help streamline the education process – including teaching, learning and administration – through the identification and assessment of students and

institutional learning goals, by tracking progress towards meeting the set goals, and the collection and presentation of data for supervision of the learning process. In this way, an LMS is not only useful for delivering learning content but also for the management of student uptake and compliance, and the analysis of knowledge and skills gaps [2].

One widely used LMS in higher education institutions around the world is Blackboard. This is a technology platform utilized by educational institutions to support the exchange of important learning content and materials, student assignments and reports, and announcements by the teacher. Additionally, Blackboard technology facilitates real-time activities

The associate editor coordinating the review of this manuscript and approving it for publication was Seifedine Kadry^{id}.

including discussion forums and chat rooms for student-student online interactions and for the transfer of documents, resources, and questions between students and teachers [3].

With advances in technology, LMSs are increasingly utilized to forecast student learning outcomes as well as to monitor student performance. The affordances of Blackboard mean that all content, interactions, and assessment tasks items can be aligned to specified goals or student learning outcomes. Alignment to activities for assessing students, including assignments, examinations, and discussion forums, allows for the collection of student performance data at the course level to establish the extent to which students are achieving the stated goals. Students can also keep track of how their learning is progressing in relation to those goals. Further, such systems generate and store large amounts of meta-data. These include but are not limited to: number of hits to the course content, number of visits to the course, duration of interactions using the online systems, number of downloads, and date of visit. This data can be utilized to generate valuable information to assist staff with the decision-making process [4], [5].

The aim of paper is to predict student learning outcomes and to monitor their performance during the educational process. The method utilizes automatically generated data from the online LMS. More specifically, we examine how seven selected Key Performance Indicators (KPIs) in Blackboard help educators to predict the learning outcomes of students. In order to achieve this goal, there is a need to apply artificial intelligence models. Artificial intelligence is referred to as to the general capacity of computers to imitate human thought and perform tasks in real-world setting, whereas machine learning refers to the types of technologies and algorithms which support systems to identify patterns, engage in decision making, and generate improvement through experience [6]. Deep Learning is generally described as a form of machine learning based on learning data representations. In this field, machine learning refers a form of artificial intelligence that includes systems which can learn from data, identify patterns, and implement decisions with minimal human intervention [7].

Deep learning permits computational models made up of multiple processing layers to 'learn' representations of data with several levels of abstraction. Deep learning is associated with significant advances in problem solving which have not been fully resolved by the artificial intelligence community. This is because it is effective at discovering intricate structures within large data sets through the use of a backpropagation algorithm [6], [7]. The algorithm is used to determine how the machine should alter its internal parameters being utilized to compute the representation in each layer from the representation in the layer before it. The deep learning process therefore involves each new level 'learning' to transform the input data into a slightly more composite and abstract representation [6], [7].

In this paper, a new deep learning model using convolutional neural networks (CNN) and long short-term

memory (LSTM) is developed to predict student performances. It provides valuable information for universities which can help to ensure the quality of their services. It can also help with the development of strategies as well as ensuring student success by providing them with tailored support based on their predicted performance.

In summary, the main contributions of this paper are presented as follows:

- 1) Analysis of the level of support provided to universities to exploit student meta-data generated from the online LMS.
- 2) Analysis of deep learning models for predicting student performance.
- 3) Analysis of the correlation and time series of student performance at university per attended course.
- 4) Comparison of the results obtained using CNN-LSTM with CNN, recurrent neural networks (RNN), LSTM, and CNN-RNN for the prediction of student performance.

The remainder of this paper is organized as follows: Section II presents a review of relevant literature. The proposed method is presented in Section III, followed by details of the experiment results and discussions in Section IV and V. Finally, Section VI presents a conclusion in the paper.

II. LITERATURE REVIEW

Most universities now utilize technology platforms to improve education service delivery. This highlights the importance of activating technology in response to changes in students' learning needs and education provision more broadly. Indeed, building a big institutional dataset of student activities is important for monitoring student retention, progression, and attainment, and can be accomplished through a LMS [8]. This literature review is divided into two parts: a) use of LMSs in education; and b) predicting student learning performance using LMSs.

A. THE USE OF LMS IN EDUCATION

Various LMSs may be adopted to facilitate educational processes such as Blackboard, Desire2Learn, Moodle, and Canvas [9]. These LMSs share similar features in that they provide asynchronous interaction, at any time, in any place. In addition, they incorporate services such as collaborative learning, video conferencing, file sharing, student grading, and a discussion forum. Significant differences among the systems are rare, however, due to the high level of competition between the systems commercially. Yet, while differences in the features of the systems are not salient, differences in usage are prevalent geographically. **Table 1** shows the general global use of various LMSs across the world. Use of Blackboard in the United States (US) and Canada is at 33%, whereas use of Moodle and Canvas are both at 20%. By contrast, use of Moodle in Europe is at 65% compared to Blackboard (12%). In Saudi Arabia, most public universities (25 out of 28) use Blackboard over other systems.

TABLE 1. Percentage of LMS in universities in the US & Canada, Europe, and Saudi Arabia [2], [9].

	US & Canada	Europe	Saudi Arabi
Blackboard	33%	12%	89%
Moodle	20%	65%	7%
Canvas	20%	NA	NA

According to a study conducted at the University of Ha'il, the Blackboard communication platform offers effective communication and content sharing features [10]. These include announcements shared by faculty members with students, chat functions, discussions, email capabilities, content sharing, a calendar, assignments, a media library, and assessments. However, studies have also identified some issues that may interfere with the ability of students and instructors to collaborate effectively over the Blackboard platform [11], [12].

Additionally, faculty members must be motivated to become proficient users of Blackboard or else they miss the benefits of its innovative pedagogies. [13] support this result, reporting that 80% of students felt Blackboard was convenient to use in learning. In addition, 34% of students at the University of Ha'il felt Blackboard improved their learning experience, and 41% of students felt it helped to improve student-instructor communication. However, these results were obtained before the University of Ha'il had implemented the use of Blackboard for all courses, as was the case during the University lockdown due to the COVID-19 pandemic. According to students at the University, Blackboard was incorporated into classroom learning systems for all courses. Moreover, faculty members continue to be encouraged to use it to support curriculum implementation.

It is noted that Blackboard creates customized course management through its software, or Building Blocks, which use open application programming interfaces (APIs) and web services produced by third-party developers. However, Blackboard does not provide a comprehensive and professional system for analyzing student performance to assist decision makers to forecast activities that best promote the achievement of program learning outcomes (PLOs). In response to this issue, we adapted effective strategies and KPIs which may assist students to improve their achievement of the PLOs.

In summary, Blackboard provides a virtual learning environment that enables easy communication between students and instructors. It also allows educational institutions to perform tasks virtually such as lectures, assignments submission, and exams. Conducting all learning tasks in one virtual environment provides auto-generated data which allows educational institutions to gain more insight into student performances, thus supporting their decision making. Further, Blackboard generates data on student interactions within the learning environment. This allows educational institutions to

broaden the measurement of student performance as well as to analyze this data to customize academic support to students and improve their overall learning experience. However, auto-generated data can be difficult to analyze due to its large volume and variety. Therefore, in the next section we analyze the level of support provided by researchers to aid educational institutions to analyze auto-generated data from virtual learning environments [14].

B. ANALYSIS OF CURRENT STUDIES ON THE PREDICTION OF STUDENT LEARNING PERFORMANCE THROUGH LMS

The use of LMSs to investigate student performance and to monitor students' learning progress has increased significantly. By applying such systems, we can potentially provide effective strategies and KPIs to help students to improve their PLOs. This section analyses the systems and methods identified in other studies which can be applied in Blackboard to achieve the goals of this research.

One technological strategy for monitoring student learning is use of the MSocial system. It is integrated into the LMS in order to monitor student activities in social networks [15]. Analysts apply this system to conduct a Social Network Analysis (SNA), which focuses on examining students' use of social media as a part of learning. Specifically, researchers apply SNA to understand, visualize, and analyze students' social participation and interaction, and how these factors may enhance the learning process.

[16] expands the approach to monitoring student progress by considering the effect of social media on student learning and the need to identify the strategies, methods, and tools which assist researchers to analyze, report, and provide recommendations to improve student performance. Teachers can gain insights into the participation of a student through a display of activities and KPIs. However, the results reported by [16] do not include the educational context, overlooking the student's role in using e-learning tools and the culture of using such tools in the learning institution. Another issue with their method is that the use of social media is dependent on several variables such as student preferences and the possible negative or positive effects of social media on student education.

Other studies highlight the importance of considering the learning approach in relation to student KPIs [17], [18]. For instance, a learning approach refers to the bridge between learning environment and learning styles as influenced by a person's character [17]. [18] refer to a learning approach as the learning motivation by which suitable strategies in teaching are implemented. However, student KPIs do not always influence student performance and their final grades. As a result, the current study does not focus on the learning approach, and specifically the environment, when interpreting data related to student KPIs and their effect on student grades.

Another method of monitoring student performance is Learning Analytics (LA), which involves the use of large

TABLE 2. Summary of literature review.

Authors	Research theme	Research sub-theme and tools	Approach	Findings
[8]	Educational quality	Communication and student activities in Blackboard.	Linking communication to the activities conducted by students.	There is a need to diagnose and overcome issues that students and instructors may face to collaborate effectively.
[12]	Educational management	Stakeholder interests in using Blackboard.	Managing data in Blackboard relates to users' interests in using the system and not only the indicators of students' activities.	The institutional environment and context are important indicators in knowledge acquisition through Blackboard.
[13]	Educational management	Stakeholder interests in using Blackboard.	Surveys on stakeholder attitudes towards the use of Blackboard in education.	At the time of the study the results were neutral. This was before the University of Ha'il placed emphasis on the utilization of Blackboard.
[15]	Student performance	LMS and KPIs.	Integrating the MSocial system into the LMS.	Applying SNA with LMSs is effective for understanding, visualizing and analyzing students' social participation and interaction, and how these factors enhance learning processes.
[16]	Student performance	LMS in social media.	Reviewing papers on learning and teaching using social network sites.	Few studies have focused on students' and teachers' practices with social network sites and their application in the LMS.
[19-24]	Information management	Dataset of student performance in educational processes.	LA to monitor student performance through a big dataset.	LA is useful for identifying students who are at risk in order to support them in the learning process.
[30]	Educational quality	LMS - institutional LA project supported by a Joint Information Systems Committee (JISC).	Big dataset in the LMS to track student activities.	LA makes it possible to identify students who are at risk due to lack of participation.
[31]	Learning approach and student KPIs	Learning environment and learning styles.	Applying the learning approach by combining learning environment and learning styles.	Student KPIs should not only be analyzed in terms of learning styles. Learning environment is also an important factor in the analysis of KPIs.
[33]	Information management	Dataset of student performance in educational processes.	Combining LA and LD.	LA and LD provide a dataset of student activities which considers the educational environment (i.e. student activities through number of clicks, essays and discussion posts).

datasets to inform faculty members of students' learning and university experiences [19]. Many researchers have focused on applying LA in the educational context [20]–[23]. Moreover, LA is used to identify students who are at risk in order to support their learning progress [24]. However, the current study focuses on both diagnosing the issues students may encounter and on proposing educational practices that may assist them to achieve the intended learning outcomes at a high level.

[25] expand on the ideas of [24] with their suggestion that measuring learning experience effectiveness should be supported by LA through feedback on learning design (LD). [26] support this view by criticizing the focus on LA without sufficient consideration of the educational environment. For example, educators identify student activities through the number of clicks, essays, and discussion posts. However, LD can assist researchers to determine which variables tend

to generalize the findings to various educational contexts, and how to action the findings [27].

Analysis of previous studies reveals a lack of research that predicts student outcomes based on their interaction with LMSs. They have focused on LA and the learning environment, while the application of a LMS to forecast KPIs related to the intended learning outcomes has not been fully covered. It appears that to assist decision-makers to match the university's general requirements with the activities which enhance the intended learning outcomes of students, a combination of Blackboard LA and KPIs would be useful [28], [29], [32]. Table 2 provides a summary of the literature review regarding methods previously employed to analyze student performance using LMSs.

It should be noted that the researchers in this study faced no issues regarding educational context when monitoring student KPIs because the context was almost identical for all

students. This was for two reasons. First, all students shared the same requirement; that is, they take their courses using Blackboard, due to the University lockdown in response to the COVID-19 pandemic. Second, student conduct with regard to the investigated courses aligned with general university requirements for all students across the institution.

The researchers encountered no issues with regard to LD as the activities were provided in the course specifications and course reports. Thus, LA was the focus of the current study as the findings would be useful for identifying the educational activities and KPIs to enhance student achievement in relation to the intended learning outcomes [34]. Educators adopting this approach can predict issues to potentially affect student learning, revise the activities designed for students, forecast possible learning competencies, and implement effective activities in general courses. Based on these perspectives, the main research question is: How do the LA of KPIs in a LMS help educators to forecast the intended learning outcomes of students? The method proposed to answer this question is introduced in the section below.

III. PROPOSED METHOD

The design goal of the proposed method is to predict student learning outcomes and performance in LMS at a higher education institution using two methods: CNN [35] and LSTM [36], [37]. By combining two methods; namely, 1) CNN to extract effective features from the data, and 2) LSTM to identify the interdependence of data in time series data, the performance prediction accuracy was improved compared with state-of-the-art methods.

The prediction framework is shown in **Fig. 1**, and the main steps of the CNN and LSTM prediction model are introduced as follows:

- 1) Collect students' data from Blackboard, a common LMS used as a tool for storing university student data efficiently over time according to an analysis of predictions of student performance.
- 2) Select the significant features and eliminate abnormal values for each course to obtain valid data on students' performance as mentioned in **Table 3**. Seven courses were selected and seven features for each course were analyzed.

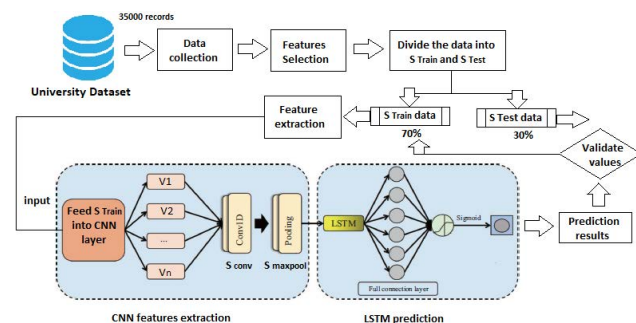

FIGURE 1. Proposed CNN-LSTM architecture diagram.

TABLE 3. Student performance during the first and second semesters (preparatory year).

Feature ID	Feature name
F1	Number of times logged into the course
F2	Total hours spent on the course
F3	Total number of participations per student in the course
F4	Total number of downloads per student
F5	Total number of assignments and projects from students
F6	Total number of attended exams and quizzes from students
F7	Total number of messages sent from students

- 3) Divide student data S into S_{Training} and S_{Testing} sets. The time series students' data is S_t , the size of training set S_{Training} is t , the size of the test set S_{Testing} is $V - t$, where V is the size of students' features in S_t
- 4) Extraction of students' features is applied by Feeding S_{Train} set into the convolutional layers and the max pooling layer of the CNN model. Input data is calculated as $S_{\text{conv}} = S_{\text{train}} * K$, $S_{\text{maxpool}} = \text{Max}(S_{\text{conv}})$. Here, S_{conv} is defined as the convolution layer result from trained data. The $*$ represents convolution operation, and K is defined as the convolutional kernel, which is the convolution window size. S_{maxpool} is the result of max pooling the layer of CNN.
- 5) Feed the extracted features of students S_{maxpool} to the LSTM model. S_{maxpool} is passed through three gates: input gate, forget gate and output gate of LSTM.
- 6) Prediction results on S_{Testing} sets are gained by training and learning.

A. DATA COLLECTION

Students' performance dataset was acquired from the report of students' KPIs based on seven general preparation courses in Blackboard. The report is a combination of one report for all students, one for each student, and one for each course. These reports are provided by the IT Department at the targeted university which include electronic data associated with the Blackboard distance learning system. They outline the general university requirements for all undergraduates according to their specializations at the university. This comes in the form of students' cumulative data which include: 1) courses, 2) activities in course, 3) assessment methods, 4) grades, and 5) materials. We utilized the students' performance dataset because it purely contains features reflecting students' academic performances and online behaviors. The dataset consists of 35,000 student records with seven features mentioned in **Table 3**. Each student studied seven courses related to four subjects: English, Mathematics, Physics, and Arabic language. As a result, the size of student record is $7_{\text{Courses}} \times 7_{\text{Features}} = 49$ per student which makes the total dataset size $35,000 \times 49 = 1,715,000$.

B. FEATURES SELECTION

Feature extraction imports student performance data from the Blackboard system and selects significant features to save into a feature vector. The features are described in **Table 3**. A 1D vector of student features is considered as the KPIs data in this paper. The selected student features as shown in **Fig. 2**. are considered in the prediction CNN-LSTM problem as an input and sequence labelling model. Both the fetched student features and the output labels are constructed as sequences and saved into a feature vector. This is denoted by an input sequence $V_{c[i]} = [V_{c[i],f1}, V_{c[i],f2}, V_{c[i],f3}, V_{c[i],f4}, V_{c[i],f5}, V_{c[i],f6}, V_{c[i],f7}]$ with $i = 1$ to $n = 7$. These features were examined for various preparatory year courses studied during the first and second semesters.

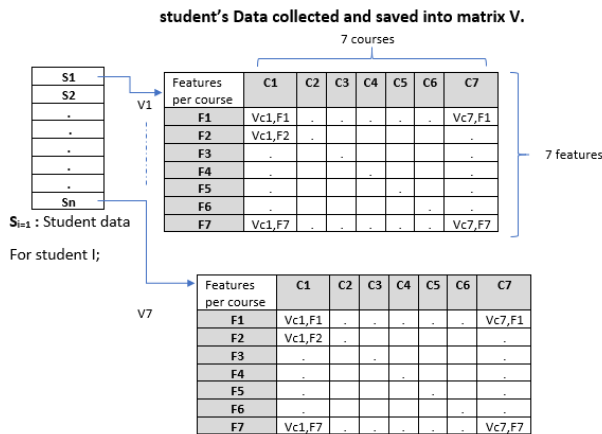

FIGURE 2. Data structure of collected student's data.

C. FEATURES EXTRACTION USING CNN MODEL

A new deep learning model using CNN and LSTM was developed to predict student performance in each course. In the proposed prediction model, CNN was used to extract the time series of student features and LSTM was used for performance prediction. This made full use of the time sequence of student data to obtain more reliable predictions. Second, by comparing the CNN-LSTM evaluation indexes with CNN [35], LSTM [36], RNN [40], and CNN-RNN [41], our method had good prediction accuracy and was better able to predict student performance within our higher education institution.

The CNN model is a type of feedforward neural network developed by [38]. CNN presents good performance in many applications such as image recognition, healthcare analysis, and predictive analytics, and is one of the most well-known deep learning models. CNN can be effectively applied to the prediction of time series data and is composed primarily of two parts: the convolution layer and the max pooling layer. In our method, four convolution layers and one pooling layer were applied. Each convolution layer contains a plurality of convolution kernels and its equation after the convolution operation is:

$$l_t = \tan h(x_t * k_t + b_t), \tag{1}$$

where l_t represents the output value after convolution, $\tan h$ is the activation function, x_t is the input vector, k_t is the weight of the convolution kernel, and b_t is the convolution kernel bias.

D. LSTM TRAINING AND PREDICTION MODEL

The LSTM model is an extension of the recurrent neural network developed by [42]. It is commonly utilized in text analysis and speech recognition. It includes a memory cell to support accurate predictions. Recently, it has also been adopted in the field of time series data prediction. The LSTM has three main components: 1) forget gate, 2) input gate, and 3) output gate as presented in **Fig. 3**.

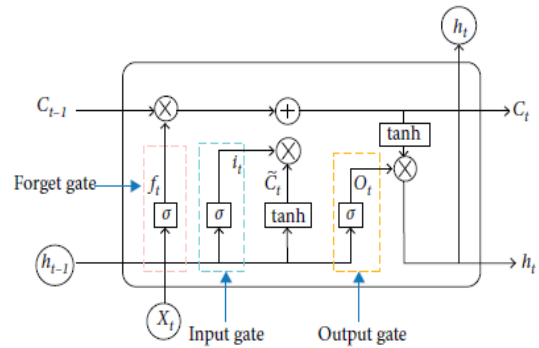

FIGURE 3. LSTM model.

The LSTM calculation process is as follows:

- a) The forget gate considers the output value of the last cell and the input parameter of the current time as its input. The output value of the forget gate is calculated as follows:

$$f_t = \sigma(W_f \cdot [h_{t-1}, x_t] + b_f), \tag{2}$$

where the output is in limit of $f_t \in [0, 1]$, W_f is the weighted value of the forget gate, and b_f is defined as the forget gate bias function. x_t is considered as the input value of the current time, and h_{t-1} is the output value.

- b) h_{t-1} and x_t are used as the input values for the input gate. The output and memory cell state of the input gate are calculated as follows:

$$i_t = \sigma(W_i \cdot [h_{t-1}, x_t] + b_i), \tag{3}$$

$$\tilde{C}_t = \tanh(W_c \cdot [h_{t-1}, x_t] + b_c), \tag{4}$$

where $i_t \in (0, 1)$, W_i is the weighted coefficient of the input gate, b_i is computed as the input gate bias function, W_c is the weight of the candidate input gate, and b_c is the bias of the candidate input gate.

- c) Change the current cell state as follows:

$$C_t = f_t * C_{t-1} + i_t * \tilde{C}_t, \tag{5}$$

where the value range of $C_t \in (0,1)$.

- d) The output h_{t-1} and input x_t are received as input values of the output gate at time t, and the output O_t of the output gate is defined as follows:

$$o_t = \sigma (W_o [h_{t-1}, x_t] + b_o), \quad (6)$$

Here, the $o_t \in (0, 1)$, W_o is the weight of the output gate, and b_o is defined as bias function of output gate.

- e) LSTM output value is using the output gate output and the state of the cell as follows:

$$h_t = o_t * \tanh(C_t), \quad (7)$$

The training and prediction steps were introduced as follows:

- a) Initialize the CNN model training parameter: W_i is the weight coefficients and the deviation b_i as shown in **Table 4**.
- b) Prepare the training set S_{Train} which includes the students' data in time series t . S_{train} represents 70% of the dataset.
- c) Fed to the S_{Train} as input layer, and passed to the CN layer to calculate S_{conv} and then transferred to the max pooling layer as S_{maxpool} according to **Fig. 1**.
- d) The effective features S_{maxpool} are extracted and then fed to the LSTM model to produce the output result h_t as shown in **Fig. 3**.
- e) The predicted values \hat{x}_i are then estimated based on the fully connected layer.
- f) To improve training in the model, data x_i is normalized as there is a reasonable distance between student data in the input gate. The z-score method is applied to normalize the input data as follows:

$$y_i = \frac{x_i - \bar{x}}{s}, \quad (8)$$

$$x_i = y_i * s + \bar{x}, \quad (9)$$

where y_i is defined as the normalized value, x_i is the input data for each student, and \bar{x} is the average of the student performance. s is the standard deviation of x_i .

- g) Error estimation: the estimated value is defined by the output gate and \hat{y}_i is compared with the observed value of this data group y_i to estimate the corresponding error.
- h) Validate if the weights $W_i \leq$ a specified criterion, predetermined number of epochs is defined that make

TABLE 4. Parameters of proposed CNN and LSTM method.

Parameter	Value
Convolution layer filters	24
Convolution layer kernel size	1
Convolution layer activation function	Tanh
Convolution layer padding	Same
Pooling layer pool size	1
Pooling layer padding	Same
Pooling layer activation function	Relu
Number of hidden units in LSTM layer	49
LSTM layer activation function	Tanh
Time step	10
Batch size	49
Learning rate	0.001
Optimizer	Adam
Loss function	Absolute Error
Epochs	100

the training model completed with the lowest error rate. Update the CNN-LSTM model and go to step 10; or else go to step 9.

- i) Propagate the calculated error in the backward way, change the weight and bias function for each layer, and go to step d to continue to train the model.
- j) Save the trained model for prediction.
- k) Set input testing S_{test} with size 30% of dataset to predict their values. For more explanation, see the flowchart of the prediction process in **Fig. 4**.

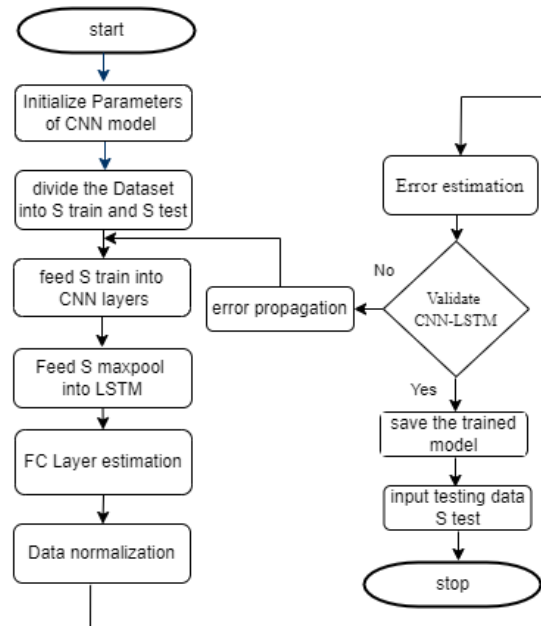

FIGURE 4. Flowchart of prediction process.

IV. RESULTS

Codes in MATLAB R2020b were used to develop the CNN-LSTM algorithm. Data were exported from the Blackboard reports for each course. The MATLAB Coder, with a Deep Learning Toolbox, was applied to generate the C++ code containing the basic framework of multiple deep neural networks using a combined CNN-LSTM method. During the experimental process, 70% of student data were selected as the training set and the remaining 30% as the test set. As for the 1D CNN and LSTM models, the number of training epochs was 100 as mentioned in **Table 4**. During training, at the end of each epoch, the accuracy of the proposed 1D CNN and LSTM model with regard to the training and test datasets were estimated. This was done to help judge whether the model was overfitting and thereby to verify the generalization ability of the current model. The first experiment was conducted based on the proposed method and evaluated based on the evaluation metric: $\text{Accuracy} = \frac{\text{\#No. of correctly predicted student data}}{\text{Total number of true students data}}$. The accuracy of our CNN-LSTM method is presented in **Fig. 5(a)** and Accuracy vs. Loss results are presented in **Fig. 5(b)**. While

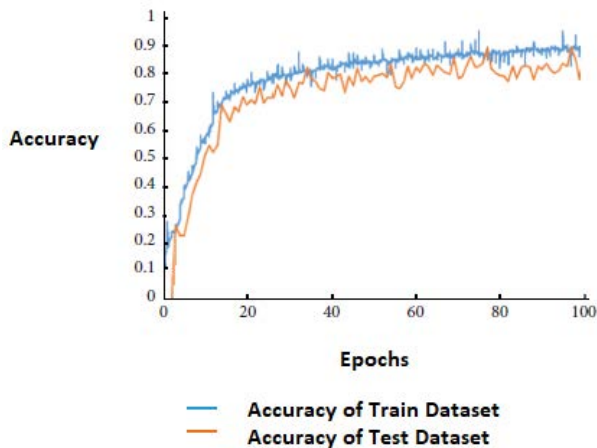

FIGURE 5. Prediction results of training and testing data in the CNN-LSTM model. Effects of epochs from 20-100 to compute training and test accuracy.

the number of epochs reached 100, the approximate accuracy of training data produces a reasonable result (96.2%), whereas the accuracy of testing data is 94.3%.

A. PERFORMANCE EVALUATION

Many factors affect the prediction model including: a) size of CNN convolution filter, b) neurons in LSTM, and c) LSTM batch size. We utilized three evaluation metrics to examine the prediction accuracy and its performance according to the above-mentioned factors:

- 1) Loss function (LOSS).
- 2) Root mean square error (RMSE).
- 3) Mean absolute percentage error (MAPE).

These metrics are defined as follows:

$$Loss = \frac{\sum_{i=1}^n |y_i - \hat{y}_i|}{n}, \tag{10}$$

$$RMSE = \sqrt{\frac{1}{n} \sum_{i=1}^n (y_i - \hat{y}_i)^2}, \tag{11}$$

where n is the number of input samples, y_i is defined as the predictive value, and \hat{y}_i represents the observed value.

$$MAPE = \frac{\sum_{i=1}^n \left| \frac{\hat{y}_i - y_i}{y_i} \right|}{n} \times 100\%, \tag{12}$$

The main goal is for loss to have the lowest rate and the lowest running time cost.

1) SIZE OF CNN CONVOLUTION FILTER

A kernel can produce dimensionality reduction of the input data which can improve the learning rate of the CNN model to extract significant features. Results of the experiment presented in Table 5 show CNN filter size=10 provides the lowest loss value and low prediction errors (RMSE, MAPE) compared with other filter sizes.

TABLE 5. Prediction rate of S_{train} data with different filter sizes.

	Filter size= 5	Filter size= 10	Filter size= 15	Filter size= 20
Loss	0.052	0.037	0.053	0.039
RMSE	0.048	0.027	0.034	0.033
MAPE	0.036	0.016	0.021	0.020

2) NEURONS IN LSTM

LSTM neurons influence prediction accuracy. To determine the best number of neurons, we examined the proposed method according to various neurons [3, 6, 9, and 12] as presented in Fig. 6. We found the optimal number of LSTM neurons is 6.

3) LSTM BATCH SIZE

The proposed model’s time complexity and memory consumption are affected by the batch size and the optimal LSTM batch size setting can be determined based on balancing the results between memory efficiency and running time. This can be done by considering the prediction loss as shown in Fig. 7. It can be seen that, when the batch size is increased,

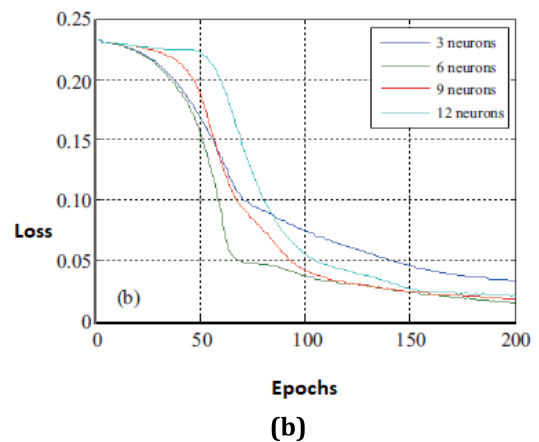
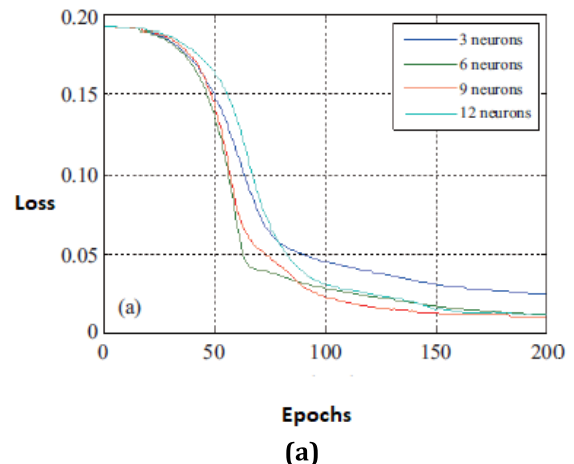

FIGURE 6. Loss vs epochs for LSTM neurons=3,6,9,12 in a) S train dataset; b) S test dataset.

the prediction (Loss) is decreased. Furthermore, the running time is increased when the batch size is increased. In the experimental results, the best batch size=100.

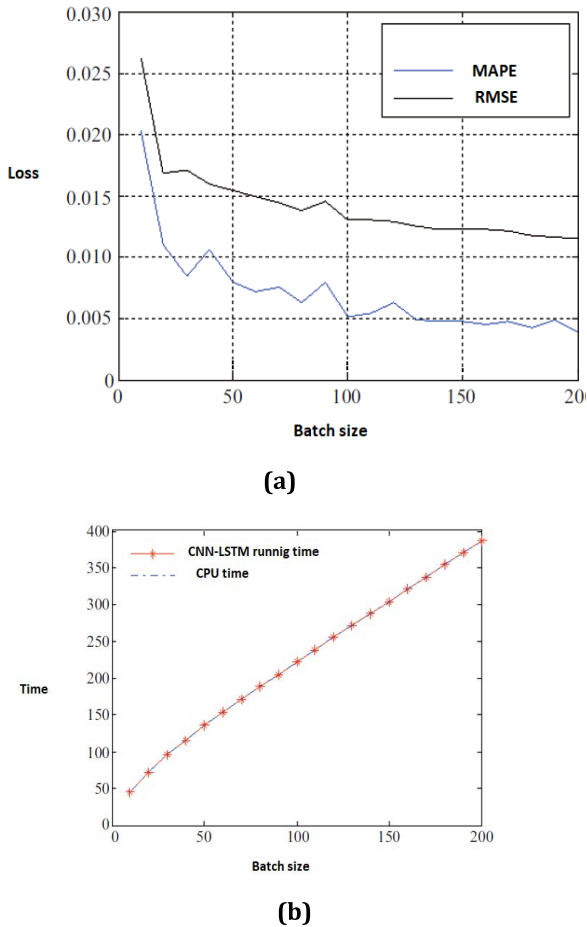

FIGURE 7. a) Prediction (Loss) for various batch sizes; b) running time based on batch size.

B. COMPARISONS

As shown in Fig. 8, we compared the CNN-LSTM model with other models: CNN [35], LSTM [36], RNN [40], and CNN-RNN [41] in terms of performance evaluation, MAPE, and RMSE. The results show that our CNN-LSTM method has the smallest prediction error compared with other methods according to $RMSE = 39.69$ and $MAPE = 27.56$.

Furthermore, the F1-score was utilized to evaluate the prediction accuracy of our method and then compared with other methods: CNN [35] and LSTM [36].

$$F1 - score = 2 \times \frac{Precision \times Recall}{Precision + Recall} \quad (13)$$

where values of TP , TN , FP and FN represent the number of true positives, true negatives, false positives, and false negatives, respectively. $Precision = \frac{TP}{TP+FP}$ and $Recall = \frac{TP}{TP+FN}$, as shown in Fig. 9, and F1-score is approximately 0.9359 which is better than utilizing CNN or LSTM only.

V. DISCUSSION

As mentioned in Tables 2 and 3, there are 7 features [F1, F2, F3, F4, F5, F6, F7] per one course C_i in our experiment.

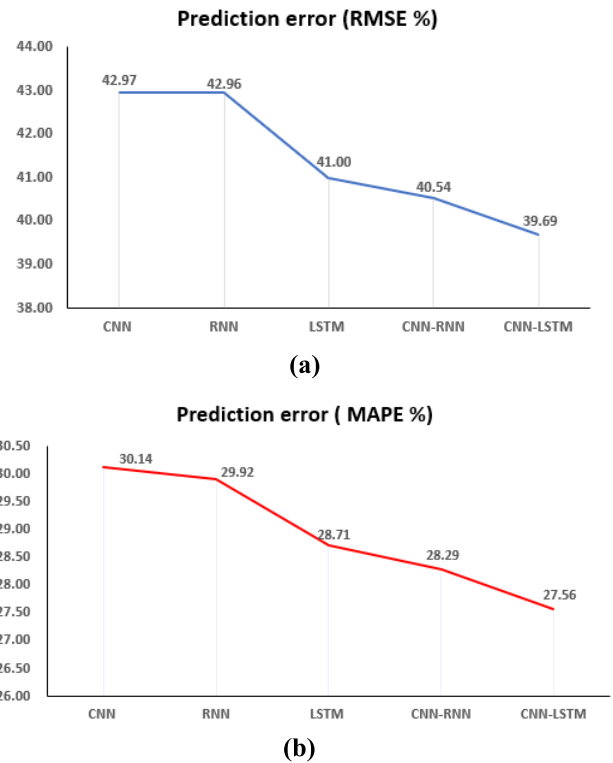

FIGURE 8. Comparisons of RMSE and b) MAPE of the proposed method with other methods.

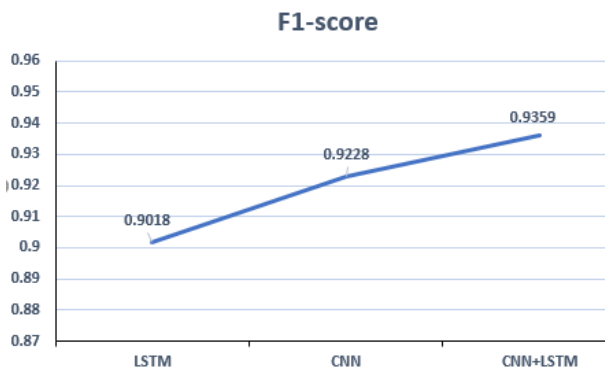

FIGURE 9. F1-score results of CNN-LSTM prediction method.

We included 7 courses $C_{i=1,2,3,\dots,7}$ selected from each student record in Blackboard. These significant features are utilized as KPIs for the students. This helped to predict the students' study behaviors using a deep learning model based on CNN-LSTM. These features were examined for various preparatory year courses studied during the first and second semester. The proposed method with selected features was examined and evaluated using precision as the criterion as reflected in Fig. 6.

The experiment as shown in Fig. 10 observed that the proposed CNN-LSTM method achieved a precision score of 94.2% using 7 features together, whereas the proposed method achieved 90.94% precision using only 3 features [F1, F2, F4]. These features represent login, time of reading course, and number of downloads. It shows how many students are interested in the selected courses. The proposed

method achieved 92.6% precision using 2 other features [F5, F6]. These features represent the assessment behaviors of student. The precision score of 89.0% was achieved using another 2 features [F3, F7]. These features represent the participation behavior of students.

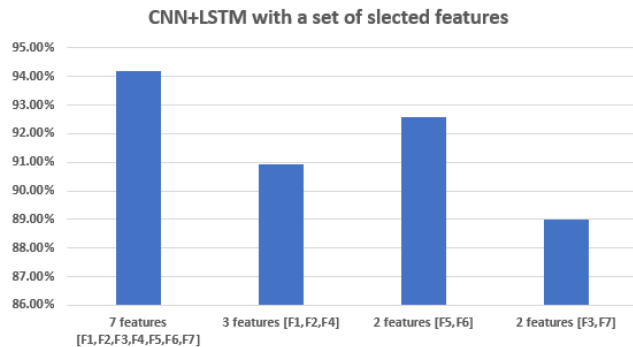

FIGURE 10. Performance evaluation of the proposed method based on selected features (F_i).

VI. CONCLUSION

This study utilized collected data generated by students' interactions with an LMS (i.e. Blackboard). We measured the effectiveness of our deep learning CNN-LSTM model for predicting student performance using prediction accuracy and prediction error. 7×7 features were selected for each student as an input of CNN layers. Three factors were regarded in the deep learning model to affect prediction accuracy and prediction error: size of CNN convolution filter, neurons in LSTM, and LSTM batch size. The limitation of the CNN-LSTM model is high time consumption when increasing the size of CNN layers, filters, and LSTM batch size. Furthermore, it is worth noting that different feature selection methods may be utilized to reveal student performance. Furthermore the CNN-LSTM deep learning model with multiple layers can learn more effectively and provides greater computing power but takes longer time to train. Thus, future studies could utilize a light weight, shallow deep learning model that offers low training time with reasonable computing power.

ACKNOWLEDGMENT

This research has been funded by Research Deanship at University of Ha'il -Saudi Arabia Through project number (RG-20 146).

CONFLICTS OF INTEREST

The authors declare that they have no conflicts of interest to report regarding the present study.

REFERENCES

- [1] N. Simanullang and J. Rajagukguk, "Learning management system (LMS) based on Moodle to improve students' learning activity," *J. Phys., Conf.*, vol. 1462, no. 1, pp. 120–144, 2020.
- [2] A. Aldiab, H. Chowdhury, A. Kootsookos, F. Alam, and H. Allhibi, "Utilization of learning management systems (LMSs) in higher education system: A case review for Saudi Arabia," *Energy Proc.*, vol. 160, pp. 731–737, Feb. 2019.
- [3] N. Kerimbayev, J. Kultan, S. Abdykarimova, and A. Akramova, "LMS Moodle: Distance international education in cooperation of higher education institutions of different countries," *Educ. Inf. Technol.*, vol. 22, no. 5, pp. 2125–2139, Sep. 2017.
- [4] R. M., N. F., and A. A., "Predicting and analysis of students' academic performance using data mining techniques," *Int. J. Comput. Appl.*, vol. 182, no. 32, pp. 1–6, Dec. 2018.
- [5] M. J. Parker, "Can BlackBoard engagement (Activity) suggest connections to student success in an online course and offer predictive value?" in *Proc. E-Learn, World Conf. E-Learn. Corporate, Government, Healthcare, Higher Educ.*, 2018, pp. 1284–1289.
- [6] I. Goodfellow, Y. Bengio, and A. Courville, *Deep Learning*. Cambridge, MA, USA: MIT Press, 2016.
- [7] Y. LeCun, Y. Bengio, and G. Hinton, "Deep learning," *Nature*, vol. 521, no. 7553, pp. 436–444, Sep. 2015.
- [8] R. Conijn, C. Snijders, A. Kleingeld, and U. Matzat, "Predicting student performance from LMS data: A comparison of 17 blended courses using Moodle LMS," *IEEE Trans. Learn. Technol.*, vol. 10, no. 1, pp. 17–29, Jan./Mar. 2017.
- [9] Z. Unal and A. Unal, "Investigating and comparing user experiences of course management systems: BlackBoard vs. Moodle," *J. Interact. Learn. Res.*, vol. 25, no. 1, pp. 101–123, 2014.
- [10] A. Ali and K. A. Sheirah, "Utilizing the blackboard learning management system at the university of Ha'il from the perspective of faculty members using Internet of Things (IoT)," *Int. J. Educ. Inf. Technol.*, vol. 14, pp. 214–222, Feb. 2021.
- [11] J. Uziak, M. T. Oladiran, E. Lorencowicz, and K. Becker, "Students' and instructor's perspective on the use of blackboard platform for delivering an engineering course," *Electron. J. e-Learn.*, vol. 16, no. 1, pp. pp1–15, Feb. 2018.
- [12] J. A. Alokluk, "The effectiveness of blackboard system, uses and limitations in information management," *Intell. Inf. Manage.*, vol. 10, no. 6, p. 133, 2018.
- [13] I. Osman, M. Nasir, and R. Alzoubi, "Blackboard usage: An investigative study among CCSE female faculty staff and students at University of Hail," *J. Econ. Manage. Perspect.*, vol. 11, no. 2, pp. 508–515, 2017.
- [14] D. Carmichael and C. MacEachen, "Heuristic evaluation of the use of Blackboard & Facebook groups in computing higher education," *Int. J. Modern Educ. Comput. Sci.*, vol. 9, no. 6, pp. 1–8, Jun. 2017.
- [15] M. J. Verdu, J.-P. De Castro, L. M. Regueras, and A. Corell, "MSocial: Practical integration of social learning analytics into Moodle," *IEEE Access*, vol. 9, pp. 23705–23716, 2021.
- [16] C. Greenhow and E. Askari, "Learning and teaching with social network sites: A decade of research in K-12 related education," *Educ. Inf. Technol.*, vol. 22, no. 2, pp. 623–645, Mar. 2017.
- [17] M. D. Lytras, N. R. Aljohani, A. Visvizi, P. Ordonez De Pablos, and D. Gasevic, "Advanced decision-making in higher education: Learning analytics research and key performance indicators," *Behav. Inf. Technol.*, vol. 37, nos. 10–11, pp. 937–940, Nov. 2018.
- [18] X. Zhang, Y. Meng, P. O. de Pablos, and Y. Sun, "Learning analytics in collaborative learning supported by slack: From the perspective of engagement," *Comput. Hum. Behav.*, vol. 92, pp. 625–633, Mar. 2019.
- [19] A. Van Barneveld, K. E. Arnold, and J. P. Campbell, "Analytics in higher education: Establishing a common language," *Educause Learn. Initiative*, vol. 1, no. 1, pp. 1–2, 2012.
- [20] R. Ferguson, "Learning analytics: Drivers, developments and challenges," *Int. J. Technol. Enhanced Learn.*, vol. 4, nos. 5–6, pp. 304–317, 2012.
- [21] A. Muslim, M. A. Chatti, M. B. Bashir, O. E. B. Varela, and U. Schroeder, "A modular and extensible framework for open learning analytics," *J. Learn. Anal.*, vol. 5, no. 1, pp. 92–100, Apr. 2018.
- [22] M. Oster, S. Lonn, M. D. Pistilli, and M. G. Brown, "The learning analytics readiness instrument," in *Proc. 6th Int. Conf. Learn. Anal. Knowl.*, 2016, pp. 173–182.
- [23] G. Siemens and D. Gasevic, "Guest editorial-learning and knowledge analytics," *J. Educ. Technol. Soc.*, vol. 15, no. 3, pp. 1–2, 2012.
- [24] N. Sclater, "Code of practice for learning analytics: A literature review of the ethical and legal issues," *Recuperado de*, Jan. 2014.
- [25] K. Mangaroska and M. Giannakos, "Learning analytics for learning design: A systematic literature review of analytics-driven design to enhance learning," *IEEE Trans. Learn. Technol.*, vol. 12, no. 4, pp. 516–534, Oct. 2019.
- [26] S. Joksimović, D. Gašević, T. M. Loughin, V. Kovanović, and M. Hatala, "Learning at distance: Effects of interaction traces on academic achievement," *Comput. Educ.*, vol. 87, pp. 204–217, Sep. 2015.

- [27] L. Toetenel and B. Rienties, "Analysing 157 learning designs using learning analytic approaches as a means to evaluate the impact of pedagogical decision making," *Brit. J. Educ. Technol.*, vol. 47, no. 5, pp. 981–992, Sep. 2016.
- [28] N. Gitinabard, Y. Xu, S. Heckman, T. Barnes, and C. F. Lynch, "How widely can prediction models be generalized? Performance prediction in blended courses," *IEEE Trans. Learn. Technol.*, vol. 12, no. 2, pp. 184–197, Apr. 2019.
- [29] Á. Hernández-García, I. González-González, A. I. Jiménez-Zarco, and J. Chaparro-Peláez, "Visualizations of online course interactions for social network learning analytics," *Int. J. Eng. Technol.*, vol. 11, no. 7, pp. 6–15, Jul. 2016.
- [30] S. Robertson, S. Humphrey, and J. Steele, "Using technology tools for formative assessments," *J. Educators*, vol. 16, no. 2, p. n2, Jul. 2019.
- [31] F. Puteh-Behak and I. R. Ismail, "Multiliteracies project approach: Dated or a worthy learning tool?" *GEMA Online J. Lang. Stud.*, vol. 18, no. 2, pp. 312–334, May 2018.
- [32] P. Kirschner, "Learning analytics: Utopia or dystopia," in *Proc. Learn. Anal. Knowl. Keynote Conf.*, 2016.
- [33] Q. Nguyen, "Unravelling the dynamics of learning design within and between disciplines in higher education using learning analytics," in *Proc. Int. Conf. Learn. Anal. Knowl. (LAK)*, vol. 17, 2017.
- [34] N. Alalwan, W. M. Al-Rahmi, O. Alfarraj, A. Alzahrani, N. Yahaya, and A. M. Al-Rahmi, "Integrated three theories to develop a model of factors affecting students' academic performance in higher education," *IEEE Access*, vol. 7, pp. 98725–98742, 2019.
- [35] S. Poudyal, M. J. Mohammadi-Aragh, and J. E. Ball, "Prediction of student academic performance using a hybrid 2D CNN model," *Electronics*, vol. 11, no. 7, p. 1005, Mar. 2022.
- [36] Y. Zhou, C. Huang, Q. Hu, J. Zhu, and Y. Tang, "Personalized learning full-path recommendation model based on LSTM neural networks," *Inf. Sci.*, vol. 444, pp. 135–152, May 2018.
- [37] D. Uliyan, A. S. Aljaloud, A. Alkhalil, H. S. A. Amer, M. A. E. A. Mohamed, and A. F. M. Alogali, "Deep learning model to predict students retention using BLSTM and CRF," *IEEE Access*, vol. 9, pp. 135550–135558, 2021.
- [38] Y. LeCun, L. Bottou, Y. Bengio, and P. Haffner, "Gradient-based learning applied to document recognition," *Proc. IEEE*, vol. 86, no. 11, pp. 2278–2324, Nov. 1998.
- [39] M. Yousefi and J. H. L. Hansen, "Block-based high performance CNN architectures for frame-level overlapping speech detection," *IEEE/ACM Trans. Audio, Speech, Language, Process.*, vol. 29, pp. 28–40, 2020.
- [40] F. Okubo, T. Yamashita, A. Shimada, and S. Konomi, "Students' performance prediction using data of multiple courses by recurrent neural network," in *Proc. 25th Int. Conf. Comput. Educ.*, 2017, pp. 439–444.
- [41] S. Khaki, L. Wang, and S. V. Archontoulis, "A CNN-RNN framework for crop yield prediction," *Frontiers Plant Sci.*, vol. 10, p. 1750, Jan. 2020.
- [42] S. Hochreiter and J. Schmidhuber, "Long short-term memory," *Neural Comput.*, vol. 9, no. 8, pp. 1735–1780, 1997.



ABDULAZIZ SALAMAH ALJALLOUD received the M.Sc. and Ph.D. degrees from the University of New England, Australia, in 2015 and 2018, respectively. He is currently working as an Assistant Professor with the College of Computer Science and Engineering, University of Ha'il, Saudi Arabia, where he is also working as the Vice-Dean of the Quality Assurance Unit. His research interests include machine learning and signal processing.



DIAA MOHAMMED ULIYAN received the Ph.D. degree in computer science (digital image forensics) from the University of Malaya, Kuala Lumpur, Malaysia, in 2016. He has been an Assistant Professor with Middle East University, since 2016. He has been with the College of Computer Science and Engineering, University of Ha'il, Hail, Saudi Arabia, as an Assistant Professor, since 2019. He is currently the Director of the Strategic Planning Unit in the college.

Furthermore, he is also the Director of the Academic Advising Unit in the college. His research interests include deep learning, computer vision, and information security.



ADEL ALKHALIL received the Ph.D. degree from Bournemouth University, Poole, U.K. He joined the College of Computer Science and Engineering, University of Ha'il, Hail, Saudi Arabia, as an Assistant Professor. His research interests include software evolution for mobile and cloud computing systems, decision support systems, and knowledge-based systems.



MAGDY ABD ELRHMAN is currently an Associate Professor in educational planning and a Quality Expert and an Accreditation Expert. He is also the Director of the Department Planning, Studies and Institutional Excellence—Deanship of Quality and Development—University of Hail.

AZIZAH FHAD MOHAMMED ALOGALI is currently a Consultant at the Saudi Standards, Metrology and Quality Organization, Saudi Arabia. He is also a Principal Consultant at Nagarro Information Technology Company. He is also the Administration Director of the American Society for Quality, Saudi Arabia.



YASER MOHAMMED ALTAMEEMI is currently an Assistant Professor with the Department of English, College of Literature and Arts, University of Hai'l. He is interested in critical discourse analysis, discourse studies, and corpus linguistics. His research interests include investigating the use of language with the consideration of institutional, social, and cultural contexts qualitatively and quantitatively through big data analytical tools.



MOHAMMED ALTAMIMI received the Ph.D. degree from Bangor University, Bangor, Wales, in 2020. He joined the College of Computer Science and Engineering, University of Ha'il, Ha'il, Saudi Arabia, as an Assistant Professor. His research interests include machine learning and natural language processing (NLP).



PAUL KWAN (Senior Member, IEEE) received the B.Sc. degree in computer science from Cornell University, USA, the M.Sc. degree in computer science from The University of Arizona, USA, and the Ph.D. degree in engineering from the University of Tsukuba, Japan. He is currently a Course Coordinator for Master of Data Analytics and Master of Business Analytics with the Melbourne Institute of Technology, Australia. His research interests include artificial intelligence, computer

vision, data science, image processing, and machine learning.

...