

Received April 28, 2022, accepted May 11, 2022, date of publication May 16, 2022, date of current version May 24, 2022.

Digital Object Identifier 10.1109/ACCESS.2022.3175515

Pollution Severity Monitoring of High Voltage Transmission Line Insulators Using Wireless Device Based on Leakage Current Bursts

OSAMA E. GOUDA¹, MOHAMED M. F. DARWISH^{2,3}, (Senior Member, IEEE),
KARAR MAHMOUD^{3,4}, (Senior Member, IEEE), MATTI LEHTONEN³,
AND TAMER M. ELKHODRAGY⁵

¹Department of Electrical Power Engineering, Faculty of Engineering, Cairo University, Giza 12613, Egypt

²Department of Electrical Engineering, Faculty of Engineering at Shoubra, Benha University, Cairo 11629, Egypt

³Department of Electrical Engineering and Automation, School of Electrical Engineering, Aalto University, 02150 Espoo, Finland

⁴Department of Electrical Engineering, Faculty of Engineering, Aswan University, Aswan 81542, Egypt

⁵Department of Electrical Engineering, Faculty of Engineering, Benha University, Benha 13511, Egypt

Corresponding authors: Osama E. Gouda (prof_ossama11@yahoo.com; prof_ossama11@cu.edu.eg) and Mohamed M. F. Darwish (mohamed.m.darwish@aalto.fi; mohamed.darwish@feng.bu.edu.eg)

This work was supported by the Department of Electrical Engineering and Automation, School of Electrical Engineering, Aalto University, Espoo, Finland.

ABSTRACT The present article describes a smart wireless online device for the severity monitoring of the contaminated insulators of high voltage transmission networks. Accordingly, the wireless developed monitor works by continuously sensing the magnitudes of the leakage current bursts and calculating its average root-mean-square (RMS) value for every second or minute as the monitor software is calibrated. Regarding, if the average of the leakage current RMS value is adjudicated by the monitor as corresponding to a probably significant scale of a power outage, the monitor transfers an alarm signal and sends a warning message to the maintenance crew members to take the action to wash the high voltage line insulators on time before the unexpected outage of the high voltage network has been occurring. The developed monitor contains the following main units: current transformer with burden resistor, Node MCU (ESP8266), solar power bank, cloud-based data storage, and smart device (Mobile or tablet). These units can be assembled to work without the need for a power source. The proposed monitor has many merits over the other monitoring devices; it enjoys little cost, easy of handling, and calibration. It has a high degree of safety, it is an online system, and its design is simple. The developed monitor is tested in the Laboratory using insulators with different pollution layers' conductivity and the findings show that the accuracy of the proposed monitor reached 91.66 % after carrying out 50 tests.

INDEX TERMS Contaminated insulators, Internet of Things, leakage currents, sensors, smart monitor system.

I. INTRODUCTION

In the high voltage power system networks, all outdoor insulators are usually exposed to serious environmental climatic conditions. Experience in the process of the tower's installations of the high voltage transmission lines (HVTLs) shows that the capability of insulators to withstand over-voltage differs from one site to another according to the places at which they are erected. Comprehensive experimental researches to study the performance of contaminated insulators have been

The associate editor coordinating the review of this manuscript and approving it for publication was Mauro Fadda¹.

reported by reference [1]. When pollutants accumulate on the HVTLs insulator surfaces and when they become moist, some pollutants are dissolved in the deposited moisture, forming an electrolyte on the insulator's surfaces. The conductance of the moist pollution layer is usually used as a measure of the severity of the insulator pollution [2], [3]. The passage of the leakage current in the moist polluted layer may lead to a flashover of the insulator's string and a power outage. Flashover of H.V.T.L insulators by pollution phenomenon can consider as a problem that faces the high voltage networks pass in the desert, near the industrial areas, and in marine areas.

The influences of this issue practically in a country like Egypt can be estimated by a statistical study carried out on the faults of medium and high voltage networks, which indicated to ~82% of the lines' faults, are done to the polluted insulators flashover [4]. Over the past decades, comprehensive efforts have been done to surveillance the polluted insulator's severity of high voltage transmission lines to minimize the electricity outages. Previous researches have used various techniques to monitor the pollution severity of high voltage polluted insulators. Such these are the measurements of the insulator surface conductivity or its equivalent salt deposited density, monitoring of the leakage current, and the use of advanced mathematical algorithms, and the tools of artificial intelligence for the analysis of the weather data. Many investigations have already carried out great efforts to surveillance the polluted insulator's severity to minimize the outages of electricity [5], [6]. Different methods are currently in use for the severity monitoring of the electrical power outage by the polluted insulators problem, they include insulator conductivity and equivalent salt deposited density measurements [2], such these methods need time-consuming and suffer from inaccuracy in determining the measured values and the possibility of destroying contamination samples while transporting the insulator samples for testing. The problem of the contaminated insulators of high voltage overhead networks can be solved, depending mainly on the used online type of permanent monitoring system, how it can effectively predict the occurrence of the H.V.T.L insulators event, and its used criteria in monitoring the pollution severity. Monitoring of the leakage current of polluted insulators is one method used early as a warning way from high voltage network failure depending on measurements of the leakage current magnitudes [7]–[10], [12]–[18] or counting its discharging pulses that exceed certain limits [12]. Such monitors need low voltage supply sources that may not be present in high voltage networks or are placed on towers that are not loaded with high voltage.

Nowadays, the techniques of the data acquisition, optical sensors, and online monitors of leakage current peak magnitudes or repetition pulses are used for surveillance of networks of the high voltage transmission lines [19] to obtain a more careful measurement for monitors operation. Means of technological progress promoted the researchers to use of smart computer programs, advanced mathematical algorithms, and the tools of artificial intelligence for the analysis of the weather data of the site of the H.V.T.L insulators and leakage current pulses for the investigation of the insulator surface seriousness during its contamination duration and for the flashover prediction of the polluted insulators early. Investigations on the flashover principles prediction proved that many characteristics can be combined simultaneously to give a warning signal when the flashover of the contaminated insulator is approached. An online monitor system that is established on the artificial neural networks which are fed by the pulses of the leakage current, and the surrounding site ecological data that can be collected from the field, is proposed

by Gouda and Khalifa [10]. Some of the proposed wireless monitors used wireless sensors for monitoring the pollution severity of high and medium network insulators [20]. Such monitors need to be fed with weather information from the site, as well as fed by a low-voltage source as they deal with a complex system of computers. Methods for monitoring and controlling the smart grids are proposed by [21].

According to the literature review, most existing studies have poor accuracy for pollution online monitoring of high voltage insulators. Based on this notice, a smart wireless monitoring device for the pollution severity of the polluted insulators is proposed that continuously senses the magnitudes of the leakage current pulses and calculates its root-mean-square (RMS) value every minute or second, yielding higher accuracy rates.

To cover the above-mentioned gap in the literature, this paper proposed a monitor based on recording the average value of leakage current RMS magnitude every second. The proposed monitor is basically different from the previous monitors, as it is a wireless device and does not need any external source from the network. The only voltage source of this monitor is the solar power bank system 5 volts. It supersedes previous ones in the sensing of leakage current continually. It occupies no extra area or land, and it does not interfere with the stable operation of the high voltage transmission system. Its cost is only some tens of dollars, so it is very cheap. Finally, it has to point out that the device design, construction, and testing in the Laboratory are the subject of the present article. In the future, the device will be tested in the field.

II. PROPOSED MONITOR COMPONENTS, CONSTRUCTION, AND OPERATION

The (IoT) is an abbreviation of the words, Internet of Things, and its definition is the network of substantial matters or “things” that are established with software programs, electronics, network connectivity, and sensors, which authorizes these objects to gather and interchange the available data [22], [23]. IoT allows sensing and remotely controlling of the objects across the network infrastructure, creating chances for more direct incorporation between the physical world and established computer-systems. This is resulting in improved accuracy; economic benefits and efficiency [24], [25]. The proposed monitoring system is made up of four main units. These can be assembled and configured to work as the proposed monitor for monitoring the leakage current of the high voltage contaminated insulators every one second. The proposed apparatus contains the following elements:

- (A) Current transformer with a burden resistor,
- (B) Node MCU (ESP8266),
- (C) Cloud-based data storage, and
- (D) Smart device (Mobile with display apps).

Figure 1 shows a simulation of the main elements comprising the suggested monitor. In this monitor, combinations of a current transformer with a burden resistor and Node MCU are used to collect data, calculate the current RMS

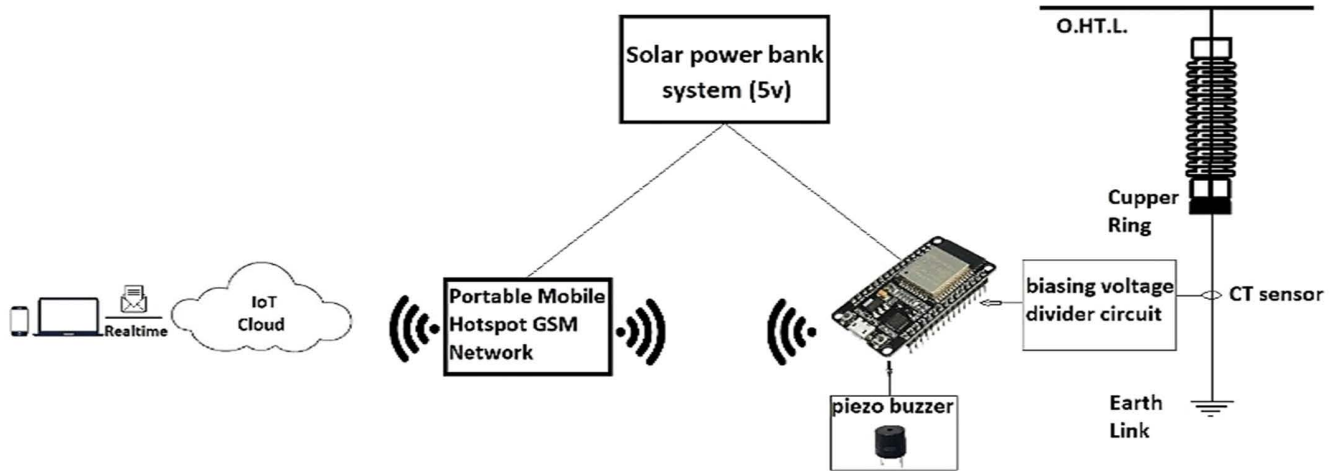

FIGURE 1. Simulation of main elements comprises the suggested monitor.

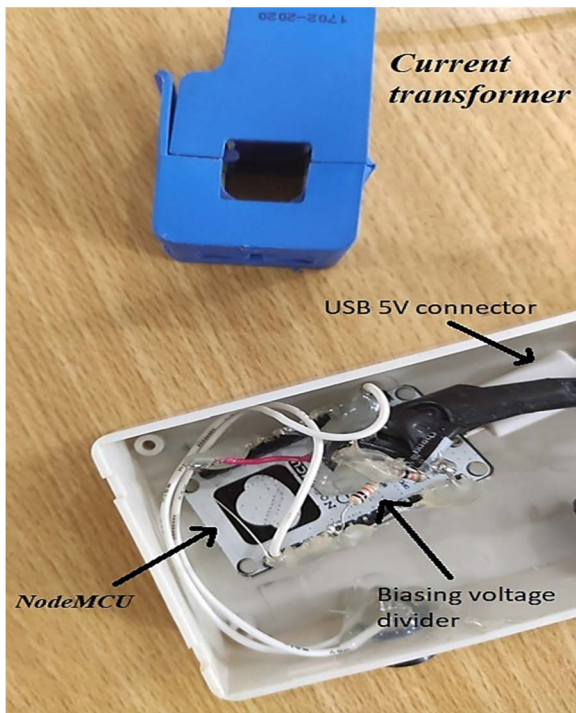

FIGURE 2. Components of the suggested monitor.

value, and send it to the cloud Platform every specific period (one second in the case of the suggested monitor). Cloud shares the collected data to the Android apparatus and controls the Node MCU over the internet network. The android apparatus is a digital dashboard where a graphic interface for any project can be built by using readymade widgets. The warning leakage current limit used in the testing of the proposed monitor is 60 mA as the RMS value for each second. The suggested monitor is characterized by good accuracy in the leakage current monitoring, its cheapness compared with other monitoring devices, and the simplicity of its design. Tests are done on the monitor in the laboratory using different

pollution layer conductivities and it gave excellent results in monitoring the leakage current severity of the contaminated insulators. In Figure 1, the GSM modem is connected to a nodemcu8266 module by a GSM/Wi-Fi modem. The GSM modem and the GSM network instead of a LTE/Wi-Fi modem are used. This choice is related to the generation of the cellular network available at the experimental site. Figure 2 gives the hardware of the components of the proposed monitor. The IoT devices gather beneficial data with the assistance of the present technologies and then independently influx the information between the sharing devices. The collected data can be analyzed to be predicted when networks need maintenance and when they will fail [26], [27].

For the choice of suitable values for the voltage divider resistances R_1 and R_2 , higher resistances and lower energy consumption, 10Ω resistances for mains powered monitors are chosen.

A. CURRENT SENSOR

The used current transformer (CT) is considered as an ideal one in which its internal burden resistance is very small. It is provided with a transient voltage suppressor that limits the output voltage in abnormal events. It has the capability of evolving adequate voltage for driving input voltage equals 5 V. In Fig. 3 an example of a used split-core current transformer is presented. Metering current transformer (5A/50 mA) with a 0.2 accuracy class (0.2 percent) to improve the accuracy to (10 mA (0.002*5A)) is used. It is sufficient for the case under study in which the leakage current threshold limit was 60 mA (6 times the accuracy) and we were looking for the threshold value to be crossed more than the accurate reading. Fig. 4 shows the CT burden resistor and biasing voltage divider circuit [22], [23]. In some cases, the insertion of a copper connection in series, such as MAX472 Current Sensor with Precision Internal Sense Resistor $35 \text{ m}\Omega$ is required for lower leakage current. To connect a current transformer sensor to a Node MCU, the output signal from the

current transformer has to be conditioned to meet the input requirements of the Node MCU analog inputs, i.e., a positive voltage between 0V and the ADC reference voltage. This can be done by using circuit [28], [29] contains mainly two parts:

1. Current transformer sensor element and its burden resistance.
2. Two resistances R1 and R2 which are used as biasing voltage dividers.

As mentioned earlier, the suitable values for the voltage divider resistances R1 and R2, higher resistances and lower energy consumption, and 10 Ω resistances for mains powered monitors are chosen.

B. NODE MCU (ESP8266)

It is used as an open source for the IoT podium. It contains firmware that operates by using the ESP8266 Wi-Fi SOC from Espressif System, and hardware that is built on the ESP-12 module. The expression “NODEMCU” in fact indicates the firmware instead of the development of the kits. The language of Lua scripting is used by firmware. The NODEMCU is established on the eLua venture and constructed on the Espressif NON-OS SDK for ESP8266. It used several open-source ventures, like spiffs and Lua-cjson. A pinpoint description is given in Fig. 5 (a). A photo of the used IoT wireless development module is given in Fig. 5(b). It can operate at a supply voltage of 3.3 volts. It is a chip with which manufacturers make wireless micro-controller modules. It has a low-cost and networkable foundation for facilitating IoT development. ESP8266 Module is not able to 5-3 V logic shifting and requires an additional Logic Level Circuit. The ESP8266 is a low-cost Wi-Fi chip with a full TCP/IP stack. It has one mega of Flash Memory. It has an onboard low-power 32-bit CPU for applications [30], [31].

C. CLOUD-BASED DATA STORAGE

For choosing the most suitable cloud data storage, several cloud data storages are tested in the system, one of them is Cloud MQTT. It is managed by Mosquito servers in the cloud. Mosquito performs the MQ Telemetry Transport protocol, MQTT, that arranges portable modes of performing messages (notice of events) using the publish/subscribe messages of a queuing model. MQTT can be considered as a machine-to-machine protocol for the future. It is considered as a suitable tool for the “Internet of Things” world for linked devices. Its minimal design makes it idealistic for compact systems, mobile phones, and other memory and bandwidth-sensitive implementations [29]–[32]. The message file provides an asynchronous communication protocol; it is not required for the receiver and the sender of the message to react with the message queue at the same time. The Message which placed in the queue is stored until the recipient restores it or until its time has been based. MQTT and Mosquito are for good use by bandwidth susceptible applications. Cloud MQTT helps in focusing on the applications



FIGURE 3. Split-core current transformer.

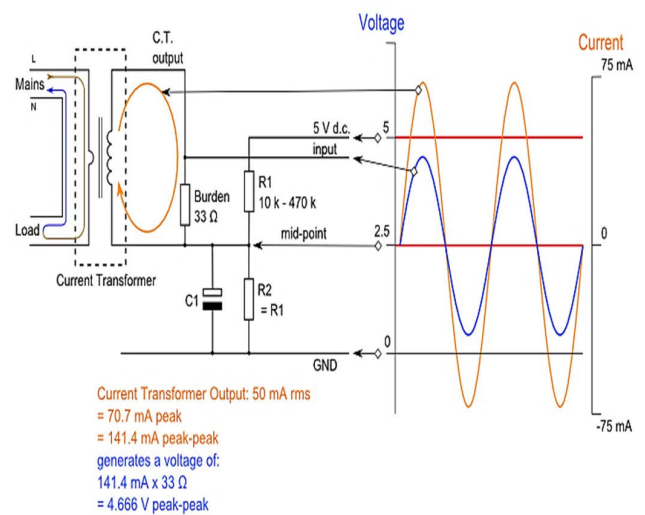

FIGURE 4. CT burden resistor and biasing voltage divider circuit [22], [23].

rather than the time loss in the broke scaling or the platform patching [33], [34].

D. SMART DEVICE (MOBILE WITH DISPLAY APPS)

It is a digital device where a graphic interface can be built for a project by simply finding the wanted data and removing the junk things. With this app, any MQTT client device with very simple configuration step can easily be controlled.

Highlighted features of the available apps in the market are

- Many connections,
- Specify all units of the data.
- Show the numerical values in real-time updating schedules.
- Able to modify the publication components.

The block diagram shown in Fig. 6 explains the operating steps of the suggested monitoring system.

III. DEVICE OPERATION THEORY

In Fig. 6, the monitor starts to read the leakage current bursts by the current transformer as a sensor; that is fixed on the top of the insulator string from the point of contact with

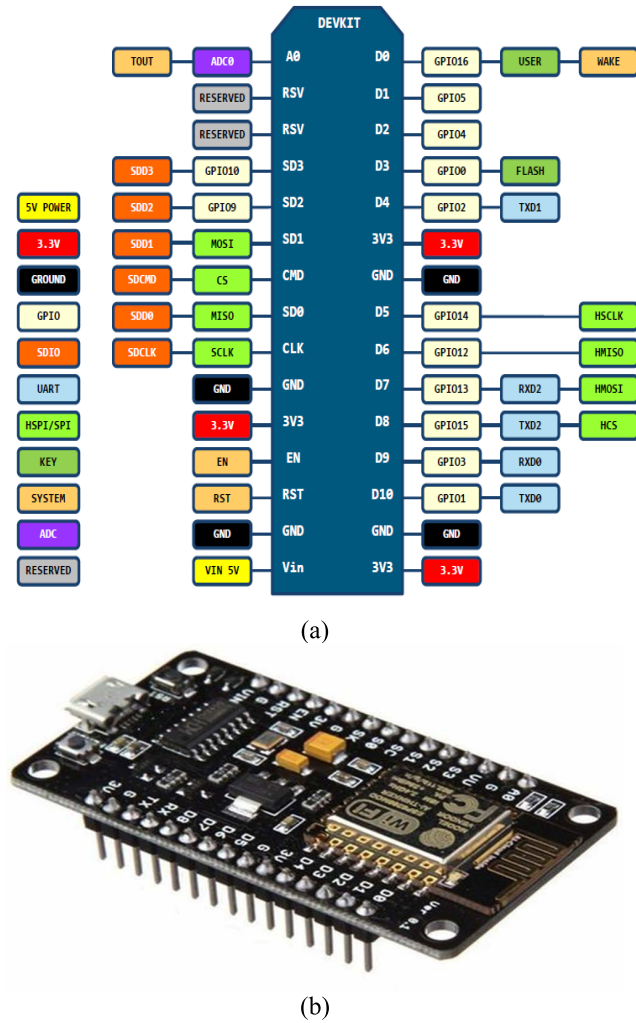

FIGURE 5. (a) Description of node MCU(ESP8266), (b) Photo of the used IoT wireless development module.

the earthed tower. Node MCU changes the analog readings to digital signals and collects the data. The calculations of the average R.M.S value of the leakage current bursts every specific period and sending it to the cloud platform has to be done by the software. It will be sent to cloud-based data storage. If it exceeds the predetermined R.M.S value of the leakage current, a local alarm program will be called, and a message will be sent to the crew of the overhead transmission line maintenance.

The device operation can be explained in steps as the following:

1. The transformer current senses the value of leakage current passing from the overhead transmission line (OHTL) insulators to the earthing system and converts it to peak voltage signal ($3V_p/400\text{ mA}$) using a CT burden resistor and biasing voltage divider circuit
2. The voltage signal received by the microcontroller (Node MCU) is converted by built-in ADC to Digital 10 bit, which means it scales an analog signal in a range of 0-1023.

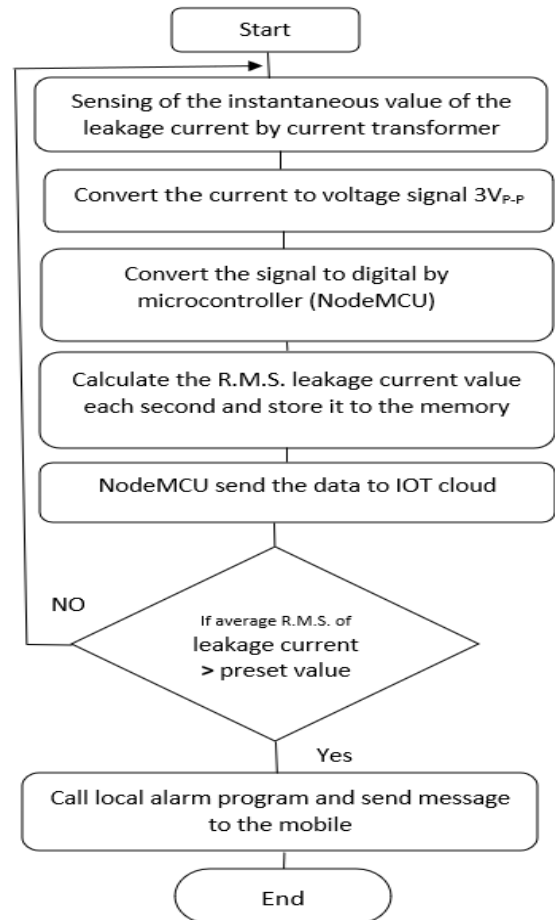

FIGURE 6. Block diagram of the suggested monitor.

3. The program calculates the current R.M.S value every second and stores it in the memory.
4. Every second the Node MCU attempt to login to the server (IoT cloud) and send the data.
5. The cloud server store the average values of the R.M.S of the leakage current and the real-time clock (time/day/month/year).
6. Mobile phone can gain access to the server to present the value of the measured current through the dashboard and receive an alert message (SMS) when the current exceeds the specified limit.

Due to the continuous functionality of the monitor code in difficult weather conditions and under electric field interference, failure inNode MCU operation may be observed when it works for a few days consecutively (more than three days). This failure could be caused by one of two reasons as the following

- 1- Temporary power insecurity, which could be caused by a variety of factors, some of which are unknown.
- 2- Code execution results in an overflow of one or more registers, necessitating the monitoring of the code's running time.

To address the first sort of failure, a software restart is planned to occur every 24 hours of continuous running to ensure that

all registers have been cleared and a power cycle has been reconnected; the time to restart and reconnect the Node MCU to the network is approximately 3 seconds; at which data will not be calculated or stored during this period; this period is extremely short and will not affect the decision of leakage current monitoring.

could be less or more depending on each setup; in our instance, it is resulted in outstanding reliability improvement and Node MCU continuously running for several months with no crash seen. To address the second sort of failure, a watchdog timer has been utilized. The Node MCU has 2 types of watchdog; one is implemented in hardware and the other in software.

A watchdog is a timer that, when the system is not reset before expiring, triggers the reset of the monitoring system. Fig. 7 gives the flowcharts of the steps used in avoiding the failure in Node MCU operation.

IV. EXPERIMENTAL STUDY AND TESTING OF THE PROPOSED MONITORING SYSTEM

A. MEASUREMENT OF POLLUTED LAYER CONDUCTIVITY OF THE INSULATOR UNDER TESTING

The contaminated insulator’s performance is usually governed by the conductivity of the pollution layer and the contamination distribution on the insulator surface or the equivalent salt deposit density of the polluted insulator. The diameter of the insulator under testing is 320 mm, its spacing equals 145 mm, the insulator leakage path equals 385 mm, and its form factor equals 0.85. The pollution layer is formed by dipping the insulation into a suspension containing 1000 gm kieselguhr, 10 gm highly dispersed silicon dioxide, an amount of NaCl to control the suspension conductivity, and 1000 cm³ water which is added in small steps with the past. The measurements of the insulator pollution layer conductivity are done according to IEC [2], [3]. The testing voltage of two 50 Hz volts for each millimeter of the total leakage path is applied to the insulator string that is tested inside a fog chamber with a temperature range between 60-70 ° C and 100% relative humidity. The voltage used in testing is applied for a time period between two to three minutes merely sufficient for measuring the peak value of the leakage current, otherwise, if the applied test voltage stays a long time the moisture will evaporate, and dry bands may be formed on the surface of the contaminated insulator. The test is reiterated at least three times separated by five minutes for the same insulator string. The conductivity of the contaminated layer is calculated using the following relation.

$$K = \frac{I}{V} F_f \tag{1}$$

where K is the insulator contaminated layer conductivity in μ S, I is the peak value of the leakage current, V is the test voltage and F_f is the form factor of the insulator. The average of the three tests is considered as acceptable value of insulator conductivity for each test.

B. THE FLASHOVER VOLTAGE VERSUS THE CONTAMINATED LAYER CONDUCTIVITY

The flashover voltage as a function of the contaminated insulator conductivity is given in Table 1. The tests are done using a single-phase testing transformer. Its output single-phase voltage equals 250 kV, its power factor at short circuit (R/X)

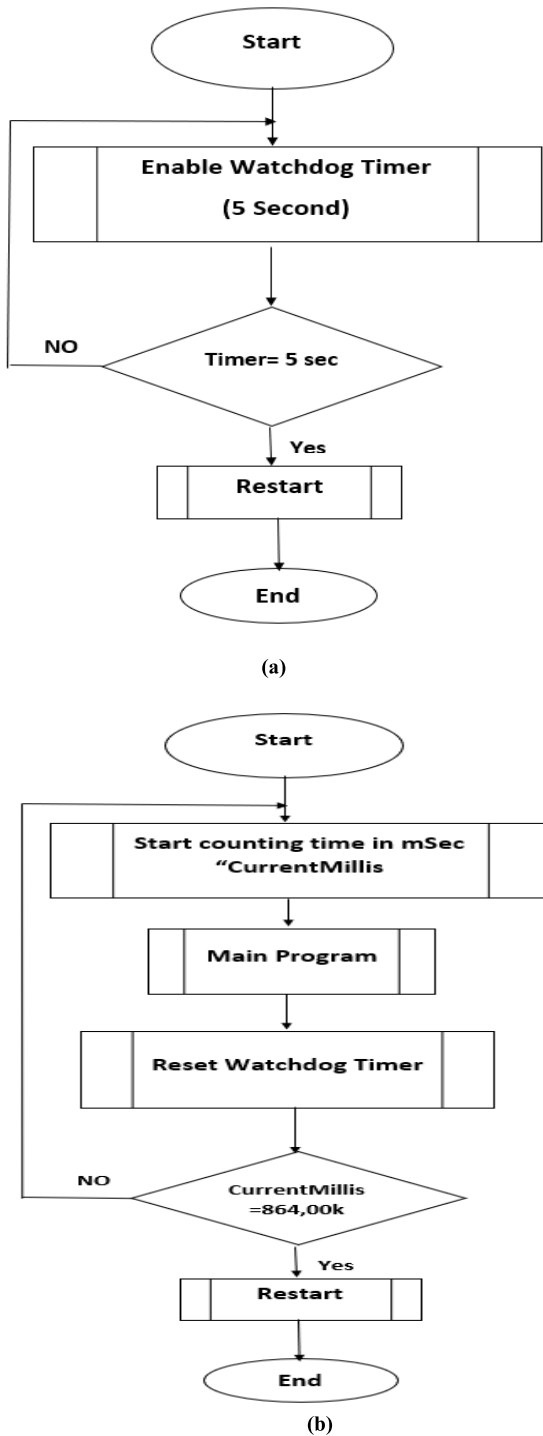

FIGURE 7. (a) Temporary power insecurity, (b) Code execution.

The 24-hour period was chosen based on the setup conditions (location, weather, size, and quality of battery) and

TABLE 1. Flashover voltage of each insulator unit versus polluted insulator conductivity.

Insulator conductivity in μS	Flashover voltage in kV
Clean	25.5
5	23.7
10	19.3
18	15.25
25	14.65
30	13.75
35	13.2

TABLE 2. The average of the R.M.S of leakage current bursts versus the applied test voltage under different surrounding conditions.

Average of the R.M.S values of the current bursts in dry condition	Average of the R.M.S values of current bursts at 30 μS conductivity	Average of the R.M.S values of current bursts at 35 μS conductivity	Test voltage (kV)	
23 mA	80 mA	90 mA	93mA	13.7
16 mA	68 mA	75 mA	81 mA	12.5
5 mA	62 mA	70 mA	76 mA	11.7

equals 0.2 and its short circuit current is 1.5 A. It is complying with IEC [2]. The warning voltage level for the pollution severity could be adjusted to 90% of the contaminated insulator flashover voltage. This criterion may be sufficient for the Laboratory tests in which the test environment can be controlled; unfortunately, it is not the condition in the field. Adjusting the level of the warning voltage to be 80% of the flashover voltage is selected as it allows for the somewhat lower values in field conditions. The proposed monitor can compare the amplitude of the average of the R.M.S value of the leakage current bursts in mA with a preset level of a similar amplitude at 90% of the flashover voltage in the Laboratory.

C. LEAKAGE CURRENT MEASUREMENTS

The measured values of the bursts of the leakage current are obtained using a direct measurement device oscilloscope across small resistance connected in series with the testing circuit. The R.M.S values of the leakage current bursts versus the applied test voltage and under different surrounding conditions are indicated in Table 2, mainly in the dry and polluted conditions. The value of I_{rms} , which is given in this table, is the mean value of the R.M.S leakage current pulses that is measured for about five tests at different voltage levels. If the leakage current RMS value exceeds the preset value, a signal will produce an alarm, and the maintenance crew of towers will carry out the insulators washing.

The calculation of the average RMS values of the leakage current bursts in the Discrete Time Domain is done by

the use of equation (2).

$$I_{rms} = \sqrt{\frac{\sum_{n=0}^{N-1} i^2(n)}{N}} \tag{2}$$

where N is the total number of leakage current pulses during one second at 90% of flashover voltage level, $n = 1, 2, n$.

Figure 8 gives samples of the current bursts on the polluted insulator surface.

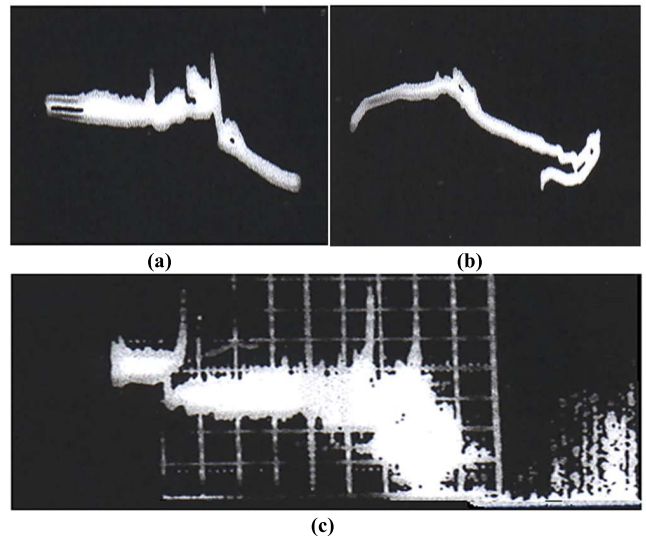

FIGURE 8. Samples of leakage currents pulses, (a) Conductivity 15 μS , Applied voltage 25 kV, 50 mV/div. 0.5 ms/div., (b) Conductivity 35 μS , Applied voltage 20 kV, 50 mV/div. 0.5 ms/div. and (c) Conductivity 35 μS , Applied voltage 22 kV, 50 mV/div. 0.5 ms/div.

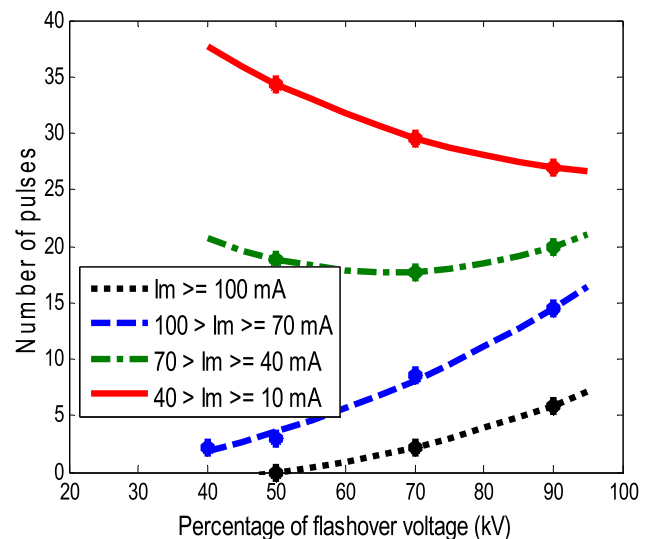

FIGURE 9. Number of leakage current bursts versus percentage of the flashover voltage (14.65 kV), time of test is 5 minutes for each applied voltage. Polluted layer conductivity is 25 (μS).

More experimental tests are done for recording the leakage current bursts in the laboratory to obtain a good contribution to the possibility of the insulator string flashover and to test

the proposed monitor operation under conditions that simulate its working in the field. Figure 9 gives the number of the maximum value of the leakage current bursts that occurred over a period of five minutes with values I_m exceeding or equal to 100, 70, 40 and 10 mA versus the percentage of flashover voltage.

Figure 10 gives a relation between average repetition times versus the surface layer conductivities when the test voltage was 90%, 70%, and 50% of the flashover voltage. It is noticed that the average repetition time decreases when approaching a state of flashover.

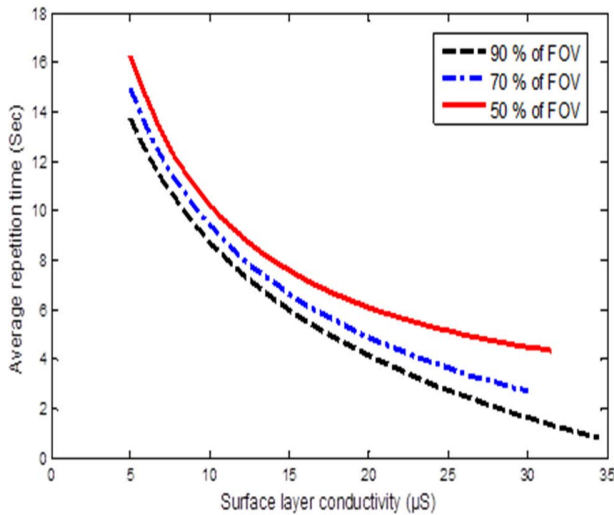

FIGURE 10. A relation between the surface layer conductivity and the average repetition time of leakage current pulses (IEC fog test).

D. TESTING OF THE PROPOSED MONITOR IN THE LABORATORY

A lot of experiments are done in the Laboratory for testing the proposed monitoring device and to check its ability to give an alarm signal when the leakage current root mean square value reaches the warning level which depends on the pollution layer conductivity and the testing voltage. The warning current level is suggested to be 60 mA. This value can be changed depending on the pollution severity in the areas at where the device is installed on the power transmission lines. The proposed device records the polluted insulators severity by continuous measurement of the leakage current (R.M.S) using a current sensor (clip-on current transforme) and converts it to a voltage signal as given in Fig. 1.

The output voltages of the current sensor in mVs represent the current pulses which are received by the microcontroller (Node MCU) converted by built-in ADC to Digital and the software program calculates the current R.M.S value every second and store it in the memory. Every second the Node MCU login to the server (IoT cloud) and send the data. The cloud server stores the value of the current. A mobile phone can gain access to the server to present the value of the measured current through a dashboard and receive alert SMS

when the current exceeds the specified limit. This specific limit current represents the critical leakage current level of the flashover of polluted insulator conductivity in mVs. When the current transformer signal reaches to be higher than the specified limi, the smart monitoring device works to send the signal to trigger the Mobile phone. Several laboratory experimental tests are done to check the reliability of the wireless monitoring device. The device testing details using the test arrangement given in Fig. 1 are tabulated as shown in Table 3. Ten tests are done with ten minutes separation between each test and the other.

The warning current level was taken as 60 mA during the device operation. Figure 11 gives the relation between the recorded current by the monitoring device versus the time, each point in this figure is the average value of RMS currents in one second. The test voltage was increased in steps from zero to 16 kV. At this value, the flashover occurred when the polluted layer conductivity was 18 µ S. As shown in this figure the device recorded the current which exceeds 60 mA after about 9 minutes from starting the applied voltage which is increased in steps until the flashover has occurred.

The details of the device testing using the test arrangement illustrated in Fig. 1 are given in Table 3. The monitor was tested with the use of different insulator surface conductivities and applied voltages. The test is repeated ten times on each polluted insulator string sample with th separation of ten minutes between every two tests.

The operating time of the proposed monitor versus the insulator string polluted layer conductivity and the applied test voltage is illustrated in Table 3. It can be observed from this table that the smart monitor manifested superior efficiency and credibility in monitoring the severity of the pollution leakage current before flashover occurrence.

The aggregate percentage accuracy of the proposed monitor can be evaluated based on its successful number of processes by using the formulas given in equations (3) and (4) [35]:

$$S_{Fj} = \frac{P_{Fj}}{\text{Total number of the device operation for each } F_j} \times 100 \tag{3}$$

$$C_{Fj} = F_j \frac{\sum_{j=1}^{j=n} S}{n} \times 100 \tag{4}$$

where;

- F_j : The polluted layer conductivity code;
- S_{Fj} : The percentage of the successful processes of the monitoring smart device;
- P_{Fj} : The number of the successful processes;
- j : Number of the monitoring smart device processes in each test ($j = 1, 2, 3, 4 \dots, n$);
- C_{Fj} : The average of the aggregate percentage of successful processes of all of the tests done on the monitor.

TABLE 3. Summary of laboratory tests done on the proposed monitor.

Polluted layer conductivity (μS)	Test voltage (kV), 90% of the flashover voltage	Time of the monitor operation starting from the applied of the test voltage (minutes)	Comments
5	21	30	Ten tests are done, with ten minutes time separation between every two tests. The device succeeded to give a message that will be sent to the crew of the maintenance without any fail
18		6	Ten tests are done, with ten minutes time separation between every two tests. The device succeeded to give a message that will be sent to the crew of the maintenance without any fail
25	13.8	3	Ten tests are done, with ten minutes time separation between every two tests. The device failed to send a message two times because of problems in the internet network
30	12.5	1	Ten tests are done, with ten minutes time separation between every two tests. The device failed to send a message two times because of an error in the current setting
35	11.7	0.5	Ten tests are done, with ten minutes of time separation between every two tests and the other and the device failed to send a message one time because of an error in the current setting

From the above table, it can be noticed that from fifty tests carried out on the proposed monitoring device in the laboratory under different polluted conductivities and test voltages, it failed five times to operate, two of them because of problems in the internet network and the others due to an error in the warning current setting.

By using the formulas given in equations (3) and (4) in the calculation of the monitor accuracy it is found that its accuracy is in the range of 91.66 % after 50 tests done on insulators having different pollution surface conductivities and test voltages as illustrated in Table 3. The monitoring device is not tested in the field because this needs the acceptance of the electricity transmission company in Egypt which is difficult to be obtained. When comparing the proposed monitor with the conventional monitors, the advantages of the suggested one can be summarized as the following:

- (i) The proposed monitor enjoys little cost, easy of handling and calibration if it is compared with the other monitoring devices; the monitor cost is in the range of a few tens of dollars.

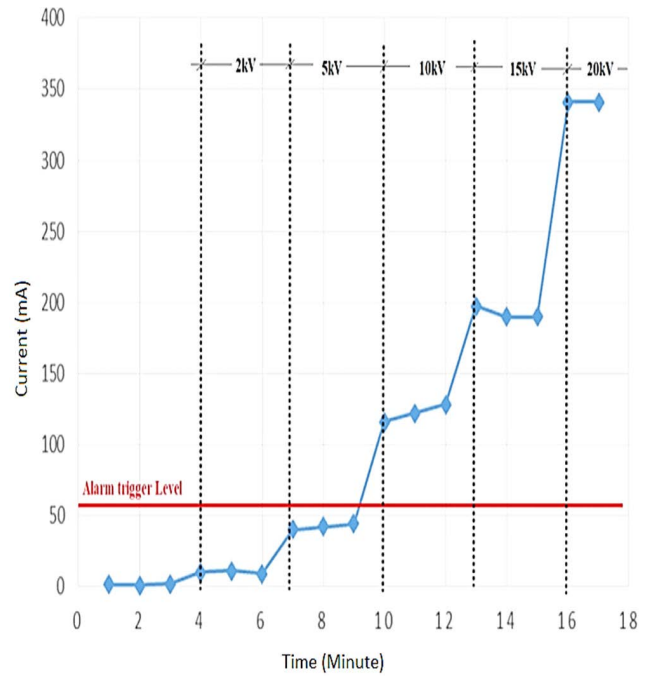

FIGURE 11. Recorded current by the monitoring device versus the time, each point in this figure is the average value of RMS currents in one second, the test voltage was increased in steps from zero to 16 kV where the flashover occurs, and the polluted layer conductivity was 18 μS .

- (ii) The monitor has a high degree of safety because it is isolated from the high voltage network by the clip-on current transformer
- (iii) The smart monitor is an online system, there is no time consumption
- (iv) The monitoring system accuracy amounted to 91.66% after 50 tests carried out in the laboratory
- (v) The design of the proposed monitoring device is simple

The monitoring device suffers from two restrictions, one of them is that problems maybe appear in the internet networks and the other is the error in the warning leakage current setting causing false operation.

V. CONCLUSION

The article proposed a new smart wireless device for monitoring the pollution severity of the HVTLs contaminated insulators. approach to the polluted insulators failure is manifested by the rise of the values of the leakage current bursts and their repetition rate. The developed smart monitor operates by continuously sensing the magnitudes of the leakage current bursts and calculating their RMS value every minute or second as the monitor software is calibrated. If the leakage current RMS value is judged by the proposed monitor as conformable to a potentially dangerous level, the monitor sends a warning message to the maintenance crew members.

The developed monitor is based on the current sensor, buzzer, and disconnect switch, Node MCU (ESP8266), cloud-based data storage, solar power bank, and smart device

(Mobile with display apps). These units can be assembled to work without the aid of the network supply. The monitor is tested in the Laboratory using insulators with different pollution layer conductivities. The accuracy of the proposed monitor reached 91.66 % after 50 tests were carried out in the laboratory. The proposed device enjoys a high degree of safety, simplicity, little cost, and easy of handling and calibration. One of the suggested device limitations is the internet network problems and reference leakage current adjustment for each polluted area at which the power lines are installed.

ACKNOWLEDGMENT

This work was supported by the Department of Electrical Engineering and Automation, School of Electrical Engineering, Aalto University, Espoo, Finland.

REFERENCES

- [1] A. A. Salem, K. Y. Lau, W. Rahiman, Z. Abdul-Malek, S. A. Al-Gailani, N. Mohammed, R. A. Rahman, and S. M. Al-Ameri, "Pollution flashover voltage of transmission line insulators: Systematic review of experimental works," *IEEE Access*, vol. 10, pp. 10416–10444, 2022, doi: 10.1109/ACCESS.2022.3143534.
- [2] *Artificial Pollution Tests on HV Insulators to be Used on AC Systems*, IEC Standard 60 507, 1991.
- [3] *Selection and Dimensioning of High-Voltage Insulators Intended for Use in Polluted Conditions—Part 2: Ceramic and Glass Insulators for A.C. Systems*, Standard IEC-TS-60815-2, Switzerland, 2008. Accessed: Feb. 12, 2022. [Online]. Available: <http://www.transformer-magazine.ir/wp-content/uploads/2015/09/IEC-TS-60815-2-2008.pdf>
- [4] *Monthly Faults Reports on Unified Egyptian Network*, Egyptian Electricity Holding Company Annual Report, Cairo, 2021. Accessed: Feb. 14, 2022. [Online]. Available: http://www.moec.gov.eg/english_new/EEHC_Rep/REP2021-2022en.pdf
- [5] J. Li, W. Sima, C. Sun, and S. Sebo, "Use of leakage currents of insulators to determine the stage characteristics of the flashover process and contamination level prediction," *IEEE Trans. Dielectr. Electr. Insul.*, vol. 17, no. 2, pp. 490–501, Apr. 2010, doi: 10.1109/TDEL.2010.5448105.
- [6] R. Castillo-Sierra, O. Oviedo-Trespalcacios, J. E. Candelo, and J. D. Soto-Ortiz, "Modeling leakage current of ceramic insulators subject to high pollution levels for improving maintenance activities," *DYNA*, vol. 85, no. 204, pp. 364–371, Jan. 2018.
- [7] J. Li, C. Sun, W. Sima, Q. Yang, and J. Hu, "Contamination level prediction of insulators based on the characteristics of leakage current," *IEEE Trans. Power Del.*, vol. 25, no. 1, pp. 417–424, Jan. 2010, doi: 10.1109/TPWRD.2009.2035426.
- [8] I. Ramirez, R. Hernandez, and G. Montoya, "Measurement of leakage current for monitoring the performance of outdoor insulators in polluted environments," *IEEE Elect. Insul. Mag.*, vol. 28, no. 4, pp. 29–34, Jul. 2012, doi: 10.1109/TPWRD.2009.2035426.
- [9] M. M. Werneck, D. M. Santos, F. V. B. de Nazare, J. L. da Silva Neto, R. C. Allil, B. A. Ribeiro, C. C. Carvalho, and F. Lancelotti, "Detection and monitoring of leakage currents in distribution line insulators," in *Proc. IEEE Int. Instrum. Meas. Technol. Conf. (I2MTC)*, May 2014, pp. 468–482, doi: 10.1109/I2MTC.2014.6860789.
- [10] O. Gouda and D. Khalifa, *On-Line Monitoring of High Voltage Transmission Line: On-Line New Methods for Monitoring of High Voltage Transmission Line Polluted Insulators*. Sunnyvale, CA, USA: LAP LAMBERT Academic Publishing, Jul. 2012.
- [11] A. Z. E. Dein, O. E. Gouda, M. Lehtonen, and M. M. F. Darwish, "Mitigation of the electric and magnetic fields of 500-kV overhead transmission lines," *IEEE Access*, vol. 10, pp. 33900–33908, 2022, doi: 10.1109/ACCESS.2022.3161932.
- [12] M. Khalifa, A. Ei-Morshedy, O. E. Gouda, and S. E. D. Habib, "A new monitor for pollution on power line insulators—Part 2: Simulated field tests," *IEE Proc. C, Gener., Transmiss. Distrib.*, vol. 135, no. 1, pp. 24–30, 1988.
- [13] N. Harid, A. C. Bogias, H. Griffiths, S. Robson, and A. Haddad, "A wireless system for monitoring leakage current in electrical substation equipment," *IEEE Access*, vol. 4, pp. 2965–2975, 2016, doi: 10.1109/ACCESS.2016.2577553.
- [14] H. de Santos and M. A. Sanz Bobi, "A cumulative pollution index for the estimation of the leakage current on insulator strings," *IEEE Trans. Power Del.*, vol. 35, no. 5, pp. 2438–2446, Oct. 2020, doi: 10.1109/TPWRD.2020.2968556.
- [15] M. Roman, R. van Zyl, N. Parus, and N. Mahatho, "Design of a hand-held, clamp-on, leakage current sensor for high voltage direct current insulators," *Int. J. Elect. Comput. Eng.*, vol. 12, no. 11, pp. 794–799, 2018, doi: 10.5281/zenodo.2021531.
- [16] Y. Yang, G. Xie, X. Xu, and Y. Jiang, "A monitoring system design in transmission lines based on wireless sensor networks," *Energy Proc.*, vol. 12, pp. 192–199, Jan. 2011, doi: 10.1016/j.egypro.2011.10.027.
- [17] L. H. Meyer, C. R. P. Oliboni, G. C. Graziano, T. I. A. H. Mustafa, H. A. D. Almague, F. H. Molina, and G. Cassel, "A study of the correlation of leakage current, humidity and temperature of 25 kV insulators in urban and rural areas," in *Proc. Annu. Rep. Conf. Electr. Insul. Dielectr. Phenomena*, Oct. 2011, pp. 398–402.
- [18] A. A. Salem, K. Y. Lau, Z. Abdul-Malek, N. Mohammed, A. M. Al-Shaalan, A. A. Al-Shamma'a, and H. M. H. Farh, "Polymeric insulator conditions estimation by using leakage current characteristics based on simulation and experimental investigation," *Polymers*, vol. 14, no. 4, p. 737, Feb. 2022, doi: 10.3390/polym14040737.
- [19] J. Wang, C. Yao, Y. Mi, X. Zhang, and C. Li, "Research for the LED optical fiber sensor for the leakage current of the insulator string," in *Proc. Asia-Pacific Power Energy Eng. Conf.*, Mar. 2012, pp. 1–4.
- [20] R. Moghe, A. R. Iyer, F. C. Lambert, and D. M. Divan, "A low-cost wireless voltage sensor for monitoring MV/HV utility assets," *IEEE Trans. Smart Grid*, vol. 5, no. 4, pp. 2002–2009, Jul. 2014.
- [21] M. Garau, M. Anedda, C. Desogus, E. Ghiani, M. Murrioni, and G. Celli, "A 5G cellular technology for distributed monitoring and control in smart grid," in *Proc. IEEE Int. Symp. Broadband Multimedia Syst. Broadcast. (BMSB)*, Jun. 2017, pp. 1–6, doi: 10.1109/BMSB.2017.7986141.
- [22] M.-Q. Tran, M. Elsis, M.-K. Liu, V. Q. Vu, K. Mahmoud, M. M. F. Darwish, A. Y. Abdelaziz, and M. Lehtonen, "Reliable deep learning and IoT-based monitoring system for secure computer numerical control machines against cyber-attacks with experimental verification," *IEEE Access*, vol. 10, pp. 23186–23197, 2022, doi: 10.1109/ACCESS.2022.3153471.
- [23] K. Ashna and S. N. George, "GSM based automatic energy meter reading system with instant billing," in *Proc. Int. Multi-Conf. Autom., Comput., Commun., Control Compressed Sens. (iMac4s)*, Kottayam, India, Mar. 2013, pp. 65–72.
- [24] *Internet of Things*. Accessed: Mar. 1, 2022. [Online]. Available: <http://en.wikipedia.org/wiki/Internet-of-Things>
- [25] M. Elsis, M. Tran, K. Mahmoud, D.-E.-A. Mansour, M. Lehtonen, and M. M. F. Darwish, "Effective IoT-based deep learning platform for online fault diagnosis of power transformers against cyberattacks and data uncertainties," *Measurement*, vol. 190, Feb. 2022, Art. no. 110686, doi: 10.1016/j.measurement.2021.110686.
- [26] A. H. Shajahan and A. Anand, "Data acquisition and control using Arduino-Android platform: Smart plug," in *Proc. IEEE Int. Conf. Energy Efficient Technol. Sustainability*, Nagercoil, India, 2013, pp. 241–244, doi: 10.1109/ICEETS.2013.6533389.
- [27] H. G. R. Tan, C. H. Lee, and V. H. Mok, "Automatic power meter reading system using GSM network," in *Proc. Int. Power Eng. Conf. (IPEC)*, Dec. 2007, pp. 465–469.
- [28] A. Conesa-Roca, R. B. Perpiñá, G. V. Quesada, and M. R. Lumberas, "Burden resistor selection in current transformers for low power applications," in *Proc. Annu. Seminar Automat., Ind. Electron. Instrum.*, Jun. 2014, pp. 25–27.
- [29] M. Hartmann, J. Biela, H. Ertl, and J. W. Kolar, "Wideband current transducer for measuring AC signals with limited DC offset," *IEEE Trans. Power Electron.*, vol. 24, no. 7, pp. 1776–1787, Jul. 2009.
- [30] P. Srividya Devi, D. V. Pusphalatha, and P. M. Sharma, "Measurement of power and energy using node MCU," *Res. J. Eng. Sci.*, vol. 2, no. 10, pp. 10–15, Oct. 2013.
- [31] S. Ganurkar and P. Gour, "Prepaid energy meter for billing system using microcontroller and recharge card," *Int. J. Core Eng. Manage.*, vol. 1, no. 1, pp. 1–7, Apr. 2014.

- [32] *Developing NodeMCU Platform With Arduino IDE Using IoT*. Accessed: Jan. 10, 2022. [Online]. Available: https://www.nodemcu.com/index_en.html
- [33] M.-Q. Tran, M. Elsis, K. Mahmoud, M.-K. Liu, M. Lehtonen, and M. M. F. Darwish, "Experimental setup for online fault diagnosis of induction machines via promising IoT and machine learning: Towards industry 4.0 empowerment," *IEEE Access*, vol. 9, pp. 115429–115441, 2021, doi: [10.1109/ACCESS.2021.3105297](https://doi.org/10.1109/ACCESS.2021.3105297).
- [34] M. Elsis, M. Q. Tran, K. Mahmoud, and D. E. A. Mansour, "Towards secured online monitoring for digitalized GIS against cyber-attacks based on IoT and machine learning," *IEEE Access*, vol. 9, pp. 78415–78427, 2020, doi: [10.1109/ACCESS.2021.3083499](https://doi.org/10.1109/ACCESS.2021.3083499).
- [35] O. E. Gouda, S. H. El-Hoshi, and S. S. M. Ghoneim, "Enhancing the diagnostic accuracy of DGA techniques based on IEC-TC10 and related databases," *IEEE Access*, vol. 9, pp. 118031–118041, 2021, doi: [10.1109/ACCESS.2021.3107332](https://doi.org/10.1109/ACCESS.2021.3107332).



OSAMA E. GOUDA was born in 1951. He received the B.Sc. degree in electrical engineering and the M.Sc. and Ph.D. degrees in the field of high voltage from Cairo University, Egypt, in 1975, 1979, and 1982, respectively. From 1988 to 1993, he was an Associate Professor with the Department of Electrical Engineering, Cairo University. In 1988, he was with the Department of Electrical Engineering, Kema Institute, Arnhem, The Netherlands, where he was

a Research Fellow. Since 1993, he has been a Professor with the Electrical Engineering Department, Cairo University. He is currently the Head of the High Voltage Group, Electrical Engineering Department, Cairo University. He has published more than 140 papers and he was a supervisor for about 70 M.Sc. and Ph.D. degrees. His research interests include the high-voltage phenomena, protection of power systems, and electromagnetic transients.



MOHAMED M. F. DARWISH (Senior Member, IEEE) was born in Cairo, Egypt, in 1989. He received the B.Sc., M.Sc., and Ph.D. degrees in electrical engineering from the Faculty of Engineering at Shoubra, Benha University, Cairo, in May 2011, June 2014, and January 2018, respectively. From 2016 to 2017, he joined Aalto University, Finland, as a Ph.D. Student with the Department of Electrical Engineering and Automation (EEA) and the Prof. M. Lehtonen's

Group. He is currently working as an Assistant Professor with the Department of Electrical Engineering, Faculty of Engineering at Shoubra, Benha University. He is also a Postdoctoral Researcher with the Department of EEA, School of Electrical Engineering, Aalto University. He has coauthored in several international IEEE journals and conferences. His research interests include HV polymer nanocomposites, nano-fluids, electromagnetic fields, partial discharge, dissolved gas analysis, fault diagnosis, renewables, optimization, the IoT, and industry 4.0. He has received the Best Ph.D. Thesis Prize that serves industrial life and society all over the Benha University Staff for the academic year 2018–2019. Since 2021, he has been a Topic Editor in *Catalysts* journal (MDPI). He also becomes a Guest Editor for the special issue in the *Catalysts* and *Energies* journals. Further, in 2022, he has nominated as a Topic Editor in *Frontiers in Energy Research* and *IET Generation, Transmission & Distribution* journals.



KARAR MAHMOUD (Senior Member, IEEE) received the B.Sc. and M.Sc. degrees in electrical engineering from Aswan University, Aswan, Egypt, in 2008 and 2012, respectively, and the Ph.D. degree from the Electric Power and Energy System Laboratory (EPESL), Graduate School of Engineering, Hiroshima University, Hiroshima, Japan, in 2016. Since 2010, he has been with Aswan University, where he is currently an Associate Professor with the Department of Electrical

Engineering, Faculty of Engineering. He has authored or coauthored several publications in top-ranked journals, including IEEE journals, international conferences, and book chapters. His research interests include power systems, renewable energies, smart grids, distributed generation, optimization, applied machine learning, the IoT, industry 4.0, electric vehicles, and high voltage. Recently, he has been awarded the Prestigious Egyptian State Encouragement Award in the field of engineering sciences for the year 2021 organized by Egypt's Academy of Scientific Research and Technology (ASRT) for his scientific contributions and achievements. Since 2021, he has been a Topic Editor in *Sensors* and *Energies* (MDPI) journals. He has also become a Guest Editor for two special issues in *Catalysts* and *Forecasting* (MDPI) journals. In 2022, he has selected as a Topic Editor in *Frontiers in Energy Research* journal.



MATTI LEHTONEN received the master's and Licentiate degrees in electrical engineering from the Helsinki University of Technology, Finland, in 1984 and 1989, respectively, and the Doctor of Technology degree from the Tampere University of Technology, Finland, in 1992. He was with VTT Energy, Espoo, Finland, from 1987 to 2003. Since 1999, he has been a Full Professor and the Head of the Power Systems and High Voltage Engineering Group, Aalto University, Espoo. His research

interests include power system planning and assets management, power system protection, including earth fault problems, harmonic related issues, high voltage systems, power cable insulation, and polymer nanocomposites. He is an Editor of *IET Generation, Transmission and Distribution* journal and an Associate Editor for *Electric Power Systems Research* journal.



TAMER M. ELKHODRAGY was born in 1975. He received the B.Sc. degree in electrical engineering from Benha University, Egypt, in 1998, and the Ph.D. degree in the field of high voltage from Cairo University, Egypt, in 2007. Since then, he has been a Lecturer in electrical engineering with Benha University. His main research interests include grounding of electrical energy systems, adaptive control application in power systems, condition monitoring, and simulation of transients on electrical networks.