

Received March 9, 2022, accepted March 26, 2022, date of publication April 25, 2022, date of current version May 3, 2022.

Digital Object Identifier 10.1109/ACCESS.2022.3168717

Mobility Robustness Optimization in Future Mobile Heterogeneous Networks: A Survey

WAHEEB TASHAN^{1,2}, IBRAHEEM SHAYEA²,
SULTAN ALDIRMAZ-COLAK¹, MUSTAFA ERGEN²,
MARWAN HADRI AZMI³, AND ABDULRAQEB ALHAMMADI⁴

¹Department of Electronics and Communication Engineering, Kocaeli University, İzmit, Kocaeli 41001, Turkey

²Department of Electronics and Communication Engineering, Faculty of Electrical and Electronics Engineering, Istanbul Technical University, 34469 Istanbul, Turkey

³Wireless Communication Centre, Faculty of Engineering, School of Electrical Engineering, Universiti Teknologi Malaysia, Johor Bahru 81310, Malaysia

⁴Communication Systems and Networks Research Laboratory, Malaysia-Japan International Institute of Technology, Universiti Teknologi Malaysia, Kuala Lumpur 54100, Malaysia

Corresponding author: Waheeb Tashan (waheebtashan88@gmail.com)

This work was supported in part by the 2232 International Fellowship for Outstanding Researchers Program of TÜBİTAK through Istanbul Technical University (ITU), Turkey, under Project 118C276. The authors would also like to acknowledge the support provided by the Ministry of Higher Education Malaysia (MOHE) under the Fundamental Research Grant Scheme (FRGS/1/2019/TK04/UTM/02/34), and in part by Universiti Teknologi Malaysia (UTM) through the Collaborative Research Grant (CRG) of R.J130000.7351.4B468, and also the Higher Institution Centre of Excellence (HICOE) Grants of R.J130000.7851.4J413 and R.J130000.7851.4J493.

ABSTRACT Ensuring reliable and stable communication during the movements of mobile users is one of the key issues in mobile networks. In the recent years, several studies have been conducted to address the issues related to Handover (HO) self-optimization in Heterogeneous Networks (HetNets) for Fourth Generation (4G) and Fifth Generation (5G) mobile networks. Various solutions have been developed to determine or estimating the optimum and ideal settings of Handover Control Parameters (HCPs), such as Time-To-Trigger (TTT) and Handover Margin (HOM). However, the complexity, high requirements, and the upcoming structure of ultra-dense HetNets require more advanced HO self-optimization techniques for future implementation. This paper studies HO self-optimization techniques that may implemented in the next-generation mobile HetNets by reviewing state-of-the-art algorithms. The solutions discussed in this survey are more focus on Mobility Robustness Optimization (MRO), which is a significant self-optimization function in 4G and 5G mobile networks. The applied solutions will preserve the continuous connection between the User Equipment (UE) and eNBs during UE mobility, thereby enhancing connection quality. The various algorithms and techniques applied to HO have revealed different outcomes. This paper discusses the pros and cons of these techniques, and further examines HO self-optimization challenges and solutions. New future directions for the implementation of HO self-optimization are also identified. This survey will contribute to the understanding of the issues related to mobility management, particularly in relation to the self-optimization of HO control parameters in future mobile HetNets.

INDEX TERMS Handover, handover control parameter, handover margin, handover parameter optimization, handover self-optimization, heterogeneous networks, mobility robustness optimization, time-to-trigger, 5G network.

I. INTRODUCTION

Recent years have seen the rapid increase in the number of wirelessly connected devices, leading to the increased demand for high system capacity and data rate transmission [1], [2]. By the end of 2021, Fifth Generation (5G)

The associate editor coordinating the review of this manuscript and approving it for publication was Jie Gao¹.

subscriptions are expected to reach up to 580 million. By 2026, it is expected to reach up to 3.5 billion [3]. To cope with massively growing demands, the Heterogeneous Network (HetNet) has been proposed as a promising and practical solution for future mobile networks. The HetNet manages different access technologies with various cell sizes. It consists of a large number of Small Base Stations (SBSs) deployed to overlap with macro cells [4], [5]. In HetNets, the main

objective of deploying a large number of SBSs (i.e., micro cells, pico cells and femto cells) is to enhance system capacity and throughput, especially at the congested areas such as dense cities, stadiums, shopping malls and city centres [6]. SBSs are defined as low power nodes that cover a specific small range of up to hundreds of meters. SBSs can also be autonomously operated or incorporated with the macro cell [7], [8]. However, the deployment of SBSs introduces critical challenges during Handover (HO) such as increases in the number of necessary and unnecessary HOs, Handover Ping Pong Probability (HPPP) and Radio Link Failure (RLF), thereby degrading the assigned Quality of Services (QoS) and Quality of Experience (QoE) [9]–[11]. This will increase the Interruption Time (IT) which subsequently leads to additional degradation in QoE. This will negatively influence user satisfaction. Maintaining connection quality between the User Equipment (UE) and the Evolved Node-B (eNB) during the transition of UEs from the eNB to another eNB is crucial in mobile networks [12], [13].

The Mobility Robustness Optimization (MRO) function has been introduced by the Third Generation Partnership Project (3GPP) group as a part of the Self-Optimization Network (SON) functions [14]–[17]. It is a significant solution for mobility management in 5G mobile networks [18]–[20]. MRO aims to perform automatic adjustments (auto-tuning) for Handover Control Parameter (HCP) settings to maintain the connection quality of the UEs. The main aim of MRO is to automatically optimize HCP settings, i.e., Time-To-Trigger (TTT) and Handover Margin (HOM), with minimal human intervention. The optimization process is performed based on various methods depending on the designed algorithms. The goal of the designed algorithms is to maintain the connection quality between the UEs and the serving eNB above a certain value during communication.

Several MRO algorithms have been proposed throughout the literature to address mobility issues and provide further enhancements [21]–[27]. Each algorithm utilizes different methodologies and deployment scenarios, providing distinct performance and accuracy levels. Several Key Performance Indicators (KPIs) have been applied to evaluate each MRO algorithm. The most common KPIs used are Handover Probability (HOP), Handover Failure (HOF), HPPP, RLF, IT, throughputs, Cell Dropping Ratio (CDR) and Cell Blocking Ratio (CBR). These KPIs are significant in identifying the performance of the proposed algorithms. The main aim of MRO algorithms is to minimize the HPPP and RLF, which are prioritised in the evaluation [17].

In previous works, articles [28] and [29] have investigated MRO in 5G networks using various scenarios. In [28], the authors proposed the MRO algorithm based on the Received Signal Reference Power (RSRP). They evaluated the performance of the proposed algorithm in terms of outage probability, HOP and HPPP in the 5G network. Article [29] had also investigated the automatic optimization of HCPs with different mobile speed scenarios in the 5G network. In the study, it was assumed that the vehicle speeds ranged

from 40 km/h to 140 km/h. The performance evaluations were accomplished in terms of RSRP, HOP, HPPP and RLF. Abdulraqueeb *et al.* [23] proposed the Auto-Tuning Optimization (ATO) algorithm using the user-speed and RSRP to adapt HCPs. The ATO algorithm adjusts HCPs for SBSs. However, the traffic load of the network and the Received Signal Reference Quality (RSRQ) were not considered, although they directly contribute to system performance [24]–[26]. In [27], the contradiction among KPIs (i.e., RLFs and ping-pongs) were optimized. It was stated that the RLF must decrease HOM to mitigate late HO, whereas HO ping-pong must increase HOM.

Several other algorithms have been developed throughout the literature based on different methodologies [30]–[34], such as the UE speed [24], [34], RSRP [31], the UE speed with RSRP [32] and the UE speed with system load [35]. Besides, article have surveyed a fundamental concepts of HO management in mobile networks, with special focus on the deployments of LTE and 5G new radio. Furthermore, a general overview of the HO techniques and mobility has been highlighted.

The *Fuzzy Logic Scheme* was also considered and used in [4], [35]–[40] as one of the proposed solutions to enhance HO performance. In [4], the authors proposed the Fuzzy Logic Controller (FLC) scheme that applies user-speed and radio channel quality to auto-tune HOM. The aim of the proposed algorithm is to minimize the HPPP rate and HOF ratio while exploiting the benefits of deploying dense SBSs. The simulation results revealed that the proposed algorithm insignificantly minimized the HPPP effect (by less than 1%). The HOF ratio was reduced to less than 3% with respect to the algorithms presented in the literature of [4] where the HOF ratio had recorded up to 5%. These algorithms were conventional Long-Term Evolution (LTE) HO [41], fuzzy multiple-criteria cell selection [40] and self-tuning HO algorithm [39]. An adaptive TTT in the algorithm of [4] should have been applied for more system accuracy. Another Fuzzy-Analytic Hierarchy Process (Fuzzy-AHP) algorithm was introduced in [37] based on the Received Signal Strength (RSS), velocity, bandwidth, load on eNB, power transmission, dwelling time (the amount of time spent by the user in one cell) and cell radius. The scheme aims to achieve optimum network selection during HO. The simulation results demonstrated that the fuzzy-AHP method reduces HOF, however, RSRQ was not included as an additional parameter in this study since it influences system accuracy.

In recent years, *Machine Learning (ML)* algorithms have been applied as solutions for HO parameter self-optimization in HetNets [25], [26], [42]–[48]. The algorithms in [26], [44], [47], [48] employed the Q-learning optimization algorithm with FLC, known as fuzzy Q-learning. In [45] and [46], the authors proposed the unsupervised ML (K-means clustering algorithm) and Q-learning to optimize HCP settings, respectively. In [25], the AHP-Technique for Order of Preference by Similarity to Ideal Solution (AHP-TOPSIS) algorithm has been proposed to optimize HCP settings. In [42] and [43],

a neural network multilayer perceptron method was used for obtaining the optimal points of the HCPs during HO. These diverse methods and techniques have contributed to enhancing system performance. Each approach exhibits different outcomes toward achieving the optimal selection of target eNBs and triggering points of TTT and HOM. The aforementioned studies are capable of enhancing specific KPIs, but at the expense of other KPIs. For instance, increasing HCP levels will lead to decreased HPPP, especially with high mobile speeds. Sometimes, it will further increase the RLF and vice versa. Not all network deployment scenarios and KPIs have been considered and investigated in each algorithm. This leads to the conclusion that there is no comprehensive study that has considered all deployment scenarios and all KPIs.

Although there is a variety of available MRO algorithms throughout the literature, no algorithm can provide an optimal solution as of yet. Achieving ideal triggering settings for HOM and TTT remains to be the main research issue that must be addressed. In recent years, the advancement of the transportation system has created a new challenge to the field of mobility management. Further evaluations are still required to achieve optimal functions that efficiently deal with high-speed scenarios for various 5G applications. 5G will support many use-cases, such as ultra-reliable communication, which requires better HO procedures that tailor to these high requirements. The implementation of the Millimetre Wave (mmWave) also leads to the increase in the number of HOs since coverage is very small due to its high path-loss characterisation [49]–[52]. Addressing the mobility issue in 5G and future mobile HetNet remains to be the major target that must be accomplished.

The main contributions of this survey are summarized as follows:

- To the best of our knowledge, comprehensive surveys on HO self-optimization in future mobile HetNets remain lacking. Thus, this study is comprehensively focusing on HO parameter self-optimization function, which is also known as MRO functions, to be as a comprehensive review paper and more in deep in this specific area by examining the state-of-the-art algorithms. Introducing such a study will open up prospects for future research of HO self-optimization in HetNets.
- This paper extensively explains the relevant studies to illustrate the algorithms that have been previously proposed in the literature until now. Each available study is successfully summarized. This summary includes the motivation of the study, the proposed solution, the methodology, the findings and the shortcomings.
- The challenges facing HO self-optimization are extensively and individually explained in the following subsections.
- This survey lists and groups the available solutions in an independent section to simplify the understanding of the techniques used in the literature for developing the MRO algorithm.

- This paper further highlights future research directions that should be analyzed in future.

The rest of this paper is organized as follows. Section II presents the research background in the context of HO self-optimization in HetNet. Section III examines the related studies. Section IV discusses the HO self-optimization challenges. Section V presents the solutions for HO self-optimization. Section VI highlights future research directions. Finally, Section VII concludes the paper.

II. RESEARCH BACKGROUND

The evolution of mobile communication systems, starting from the First Generation (1G) onwards, have frequently changed in many aspects. The 1G only supports voice services. The Second Generation (2G) added short text services, which was followed with internet services by the Third Generation (3G). High quality videos and internet streaming are now supported by the current generation of mobile communication networks [53]. This development continues since the ever-increasing number of connected devices, applications and various services always require high capacity and data transmission rates. Although the current mobile communication technology provides a high data transmission rate, the 5G revolution will offer significant features in terms of ultra-high data rate, lower latency and higher bandwidth. The ultra-dense 5G SBSs will significantly contribute to providing higher capacity, from 10-100x [5]. Sizes and Radio Access Technologies (RATs) are not similar for all SBSs which lead to heterogeneity in the aspect of spectral usages and network architecture. One major problem that will be faced in future mobile HetNets is the mobility HO issue. This must be carefully addressed. This section provides a brief description and background of HO and related functions.

A. HANDOVER IN HETNETS

HetNet is a significantly promising solution for next-generation mobile networks. It will efficiently offer high capacity, high data rates and wider coverage, especially at cell edges. In future mobile HetNets, integrating low power SBSs (i.e., micro cell, pico cells and femto cells) within the coverage of high power towers (i.e., macro cells) will lead to low cost and energy efficient solutions to satisfy 5G standards in terms of QoE [46], [54]. HetNets manage different access technologies and sizes of a large number of SBSs deployed within the coverage of macro cells to satisfy next-generation wireless communication requirements, as described in Fig. 1. The massive deployments of SBSs will lead to increased HOP during user mobility. This case is further exasperated with high mobility scenarios. Mobile users will require more efficient and seamless HO to ensure the connection quality between UEs and eNBs.

HO is a process that has been used for a long time but needs to be updated with the advancement technology. The performance of the network depends on the successful implementation of HO, especially for mobile users. Since users can move both on foot and with very fast vehicles, the HO

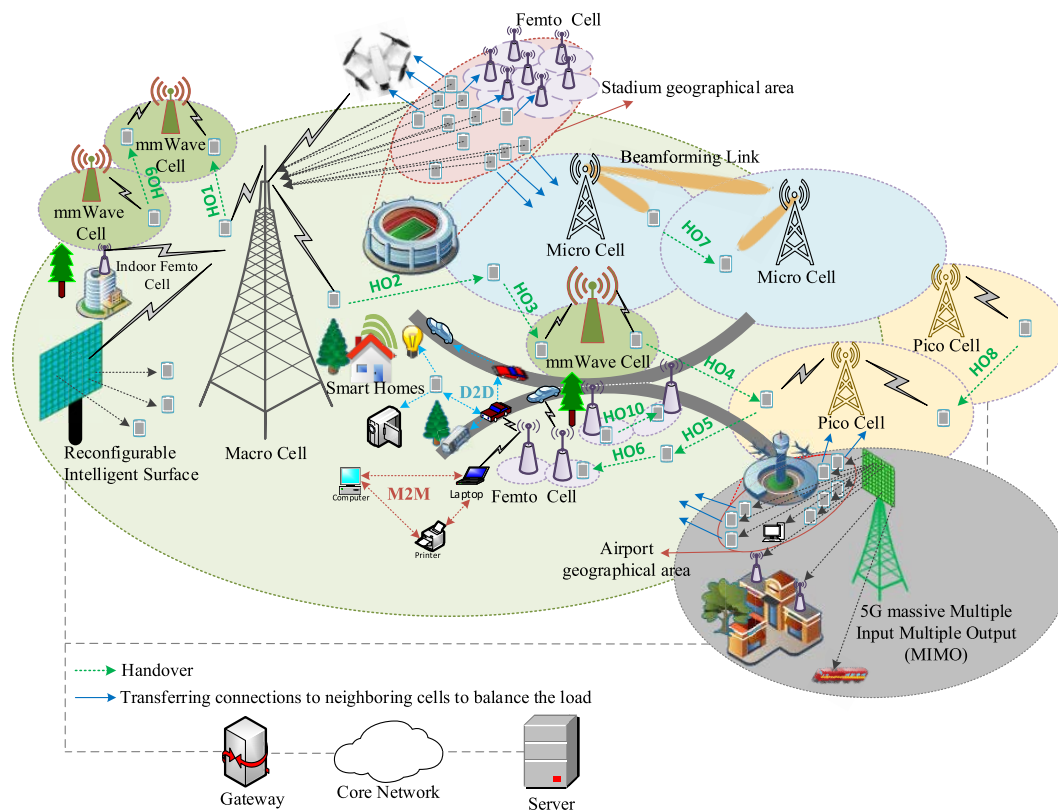

FIGURE 1. HO concept and load balancing in ultra-dense HetNets.

process should be planned to include all these users. Today, deep learning and machine learning have been proposed as solutions to many problems such as obtaining the optimal HO triggering point [55]. HO is one of those problems. In this study, we tried to examine all these issues and examine the existing studies in the literature.

Fig. 1 also illustrates several horizontal and vertical HOs with various scenarios. For instance, if both the serving cell and target cell employ the same RAT, the HO process is then identified as horizontal HO. The other case is known as vertical HO. Vertical HO may occur due to the overlapping deployment scenarios of various RAT. For example, a serving macro cell may execute a HO to a target SBS for the enhancement of UE’s data rate. It may also transfer the UE from a serving SBS to a target macro cell during the high-speed scenario to avoid unnecessary HO. Vertical HO is more critical than horizontal HO in terms of process complexity since it may lead to HOFs. Severe deterioration of system performance may also occur due to different RATs in vertical HO [56]. It can be concluded that the HO rate in future mobile HetNets will massively increase.

B. HANDOVER CONTROL PARAMETERS

HCPs are important control settings that play a crucial role in managing the HO procedure. TTT and HOM are considered as the two main control parameters usually used to control the

HO procedure. They significantly contribute to maintaining the connection quality of UEs.

Fig. 2 provides a general description of the two main HCP settings (i.e., TTT and HOM) in regard to the HO decision. The HO decision is executed when the RSRP received from the target cell ($RSRP_{target}$) is greater than the RSRP at the serving cell ($RSRP_{serving}$) at the HOM level. This received power should be measured several times at the UE depending on the TTT interval. This illustrates how HCP settings can control the HO decision.

In previous mobile networks before 4G, HCP settings were fixed values that were manually adjusted when necessary. These manual adjustments have created a critical challenge in terms of operational costs and network efficiency. Various settings may create numerous issues. For instance, if higher HCP settings are assigned, the HPPP will decrease. The RLF will simultaneously increase due to too late HO, as illustrated in Fig. 3(a). When lower HCP settings are assigned, the RLF will reduce and the HPPP will increase due to too early HO, as illustrated in Fig. 3(b). Unsuitable settings may cause HO to a wrong cell or raise unnecessary HO, as illustrated in Fig. 3(c) and (d). The 4G technology has introduced a new HO algorithm that performs automatic self-optimization for HCP settings with minimal human intervention.

This automatic self-optimization technology is essential for system accuracy, especially when HetNets are implemented. Several main functions have been introduced by

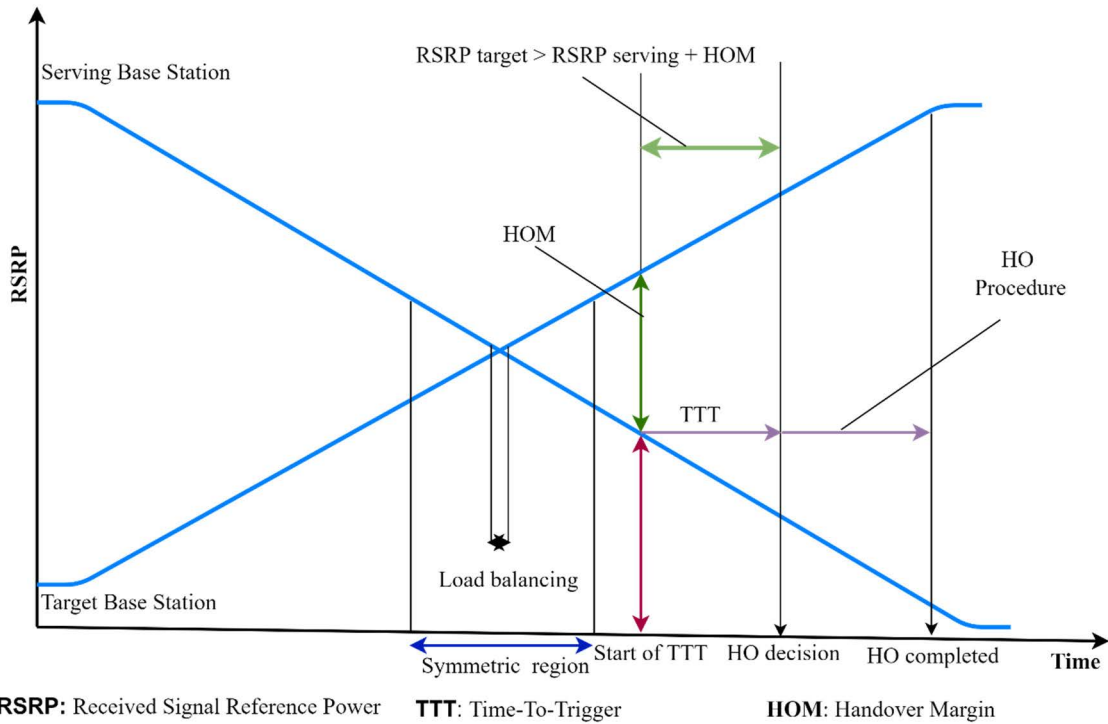

FIGURE 2. Handover decision and description of Handover Control Parameters in Mobile 5G Communication System.

3GPP to automatically adjust HCP settings, as explained in the following subsection.

C. HANDOVER SELF-OPTIMIZATION IN HETNETS

In 2008, SON was recognised as part of the 4G mobile network. It is considered to be a promising technology for future mobile communication networks [57]. SON was later defined by 3GPP release 8 as a key element for network deployment of LTE and LTE-Advanced (LTE-A) systems [19], [35]. Several automatic functions have been introduced under SON to automatically optimize network parameters. Fig. 4 presents several functions such as MRO, Load Balancing self-Optimization (LBO), Energy Saving (ES), Capacity and Coverage Optimization (CCO) and Cell Outage Compensation (COC) [28], [47].

MRO and LBO are the two main functions that automatically optimize HCP settings. They are real-time services where HO self-optimization must be executed within a very short interval of time to avoid disconnections [26]. An additional entity must be used as a coordinator to manage any contradictions of these individual functions, thereby reducing system complexity. Their main aim is to adjust network parameters for different purposes to maintain the quality of network connections between users and eNBs. The double optimization performed by these two functions may create conflicting problems. These two algorithms may independently optimize the same parameter of each other with no priority over the other, thus a conflict may arise due to this binary setting. This problem also requires independent

coordinator to overcome such contradictions [26], [58], [59]. Further details regarding these two functions are presented in the following:

1) MOBILITY ROBUSTNESS OPTIMIZATION

The MRO technique has been introduced for LTE and LTE-A as one of the HO self-optimization functions. The operation of this function aims to automatically optimize HCPs with minimal human intervention [35], [60]. The MRO automatically adjusts HCP settings (i.e., TTT and HOM) based on various proposed criteria to maintain the connection quality between UEs and eNBs during user mobility. Enabling the MRO algorithm will guarantee high QoE for mobile users.

The key goal of MRO is to minimize HO issues, specifically too late HO, too early HO and HO to the wrong cell [17]. Fig. 3 presents the various scenarios of HO problems that usually occur due to inappropriate HCP settings. Fig. 3(a) illustrates too late HO which usually results from the use of higher HCP settings. The matter becomes dire during high mobility speed scenarios since they subsequently increase the ratio of RLF. In Fig. 3(b), the HO is triggered too early, causing high HPPP and reduced RLF due to the use of lower HCP settings. This problem becomes critical during low mobile speed scenarios. In Fig. 3(c), connection is re-established by the eNB, which is neither the target cell nor the serving cell. Fig. 3(d) displays the high probability of unnecessary HO due to inappropriate HCP settings. In this case, signal fluctuations of both the serving cell and the target cell enables the exchange of successful HO execution within a

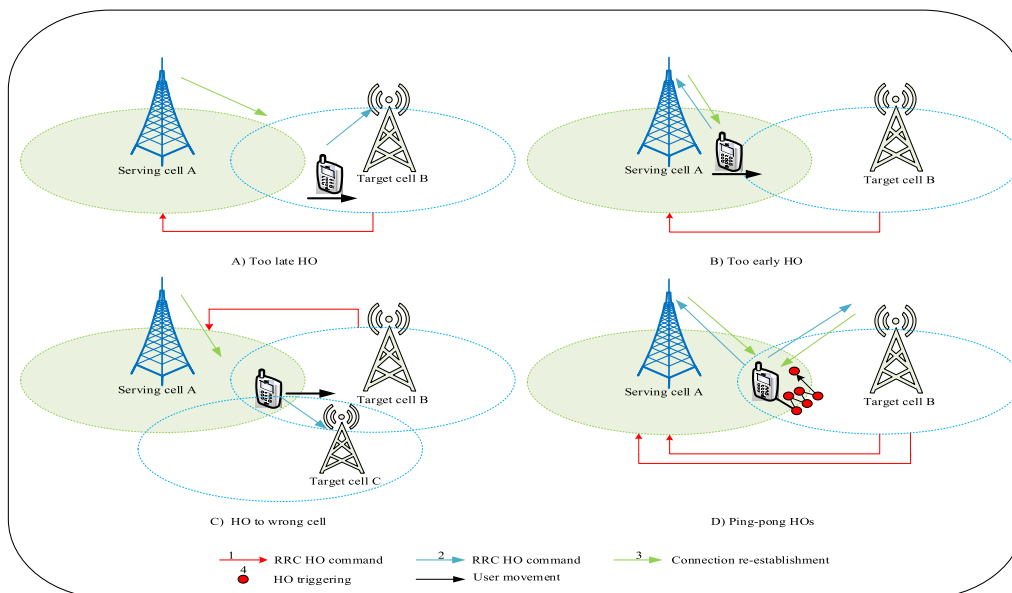

FIGURE 3. Description of handover scenarios, issues and decisions in mobile HetNets.

very short interval of time. The HO keeps triggering between the serving and target cells, causing signalling load to eNBs.

Several MRO algorithms have been developed in the literature with the aim to appropriately optimize HCP settings, i.e., achieve optimal settings for TTT and HOM. Various KPIs are used to evaluate the performance of these MRO algorithms [25], [26], [35]–[38], [44], [45], [47], [61]–[66] such as HOF, HO rate, unnecessary HOs, HPPP, RLF, CDR, CBR, throughputs and IT. These KPIs play an essential role in identifying system accuracy and performance of the proposed algorithm. These developed algorithms have been investigated with various deployment and mobility speed scenarios. Unfortunately, no optimal MRO algorithm can fully solve mobility issues.

2) LOAD BALANCING OPTIMIZATION

LBO is another self-optimization functionality that plays a crucial role for HOs. When the traffic load of the cell is high, LBO reduces the traffic load of relevant cells by offloading some users to other cells where they can acquire good service. Fig. 1 presents LBO with blue arrows to indicate where the UE’s connection switches from the overloaded cell to any cell that provides further resources [73]–[77]. This procedure significantly enhances the UE throughput. Usually, the load balancing process is applied at areas that have overlapping coverages of various cells [14], [78]–[81]. This is accomplished by allowing the UEs to execute early HO to less congested surrounding cells by adjusting HCP settings. LBO optimizes the same HCPs that MRO uses.

D. PROCEDURE OF HANDOVER SELF-OPTIMIZATION

The procedure of self-optimization has been mentioned in 3GPP [82]. The operational functionality of the

self-optimization controls the input data based on the goals and objectives of the network operators. The self-optimization functions keep on examining the input data to achieve the targets. However, a new corrective action will be executed if the targets and objectives are not met. Then, the status of the network will be evaluated based on the corrective action applied. The system configuration will revise to the previous operational step if the corrective action is not satisfied otherwise, the system completes one self-optimization step and starts monitoring the data for further optimization steps [82].

E. HANDOVER DECISION IN HETNETS

HO decision is one of the main key of HO procedure steps that initiates the HO process. More accurate decisions entail higher system performance. Several studies have been conducted to enhance appropriate HO decisions such as in [67]–[72], [82]–[92]. The serving cell decides to HO to a target cell for UEs if the applied algorithm meets the defined requirements, as shown in Fig. 2 [23], [93]. Several HO decision algorithms can be used to perform HO. For instance, HO decision based on RSS, RSS with threshold, RSS with HOM (hysteresis margin-based and TTT-based), Signal-to-Interference-plus-Noise Ratio (SINR)-based, bandwidth-based, weight function-based, cell load-based and cost function-based. The aforementioned HO decision algorithms are extensively explained in Table 1. The RSRP is considered in Algorithm (1) while SINR is the criteria of HO decision in Algorithm (2). Algorithm (3) provides the cost function-based method where C^n represents the evaluation for network n. Algorithm (4) addresses the bandwidth criteria where P_r is the unnecessary HO probability. Algorithm (5) measures the HO network quality

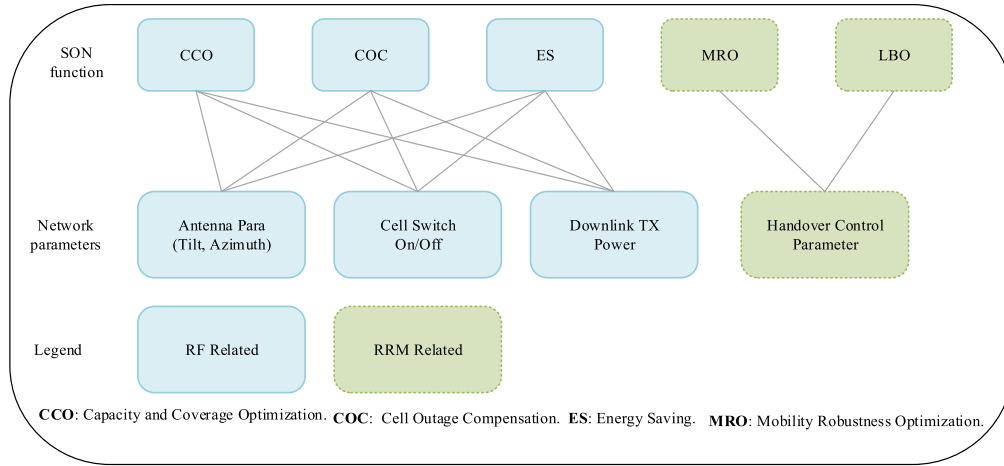

FIGURE 4. Self-Optimization functions in 5G Technology [28].

TABLE 1. Various handover decision algorithms in mobile communication systems.

Authors	Types of HO decision	Summary of the Algorithm Description
Abdulraheeb et al. [23]	RSRP	$RSRP_{target} > RSRP_{serving} + HOM$ (1)
Yan et al. [67]	SINR	$SINR_{target} > SINR_{serving}$ (2)
Zhu and McNai [68] Hasswa et al. [69]	Cost function-based	$C^n = \sum C_s^n$ and $C_s^n = E_s^n Q_s^n$ (3) where C^n represents the cost function evaluated for the network n , s is the user-requested services index, C_s^n is the per-service cost function for network n , E_s^n represents the network elimination factor for service s at the network n and Q_s^n is the QoS factor for s at n .
Chi et al. [70]	Bandwidth	$P_r = \rho I_0$ or $b_j - b_i > L$ (4) where P_r is the unnecessary HO probability, ρ is the network traffic, $I_0 = 0.001$, b_j and b_i are the bandwidth of two networks j and i and L is the bandwidth threshold.
Tawil et al. [71]	Weighted function-based	$Serving\ quality < Target\ quality$ (5)
Madaan et al. [72]	RSRP with distance	$RSRP_{target} > RSRP_{serving}$ and $R_d \geq d_{th}$ (6)

based on dropping probability, bandwidth and cost. Lastly, algorithm (6) explains the HO decision based on RSRP with and distance where the distance travelled by the user with respect to radius, R_d , should be greater than the distance threshold applied.

F. FUTURE MOBILE NETWORK TOPOLOGIES

Network topology plays an essential role in wireless systems since it has a direct impact on HO performance. Some authors have introduced a HetNet topology with different deployments of SBSs underlying the macro cells. Sectorization of macro cells and deploying a SBS in each sector as well as a random deployment of SBSs inside the macro cells has been addressed. However, deployment scenarios of the various studies have been illustrated in Tables 3, 4 and 5. These studies have investigated different simulation environments (i.e., LTE small cells [60], [94], LTE macro cells [40], 5G small cells [28], [29], HetNet dense small BSs [4], femto with macro in HetNet [31], and non-standalone 5G network [95])

which will subsequently lead to a differences in system performance in term of the number of HOs, HPPP, HOF, RLF. Fig. 5 illustrates different/similar RAT and sizes of the BSs which will impact on HO process. The HO process becomes more critical when UE’s speed increases. Moreover, due to high speed scenarios, the frequent HOs by integrating connected drones with ground BSs will be high which will subsequently influence on system performance [96]–[99]. Future mobile generation networks and drones integrated with satellite systems to serve the UEs are the future possibilities that can be implemented. Subsequently, affecting on HO performance due to the overlapped regions created by the different HetNet deployments. Hence, high number of HOs can be created which may increase the HPPP, Handover Ratio (HOR).

III. RELATED STUDIES

In recent years, consistent studies have been accomplished to solve the issues related to HO self-optimization in HetNets.

TABLE 2. Brief definition of common items used in this article.

Item	Description
A3 event	The neighbouring base BS becomes the offset better than the serving BS.
Dwell time	The amount of time spent by the user in one cell.
Handover ping-pong	The frequent HOs between the target BS and serving BS.
Handover to wrong cell	Radio link failure occurs after the successful initiation of the HO procedure to the wrong BS.
Heterogeneous network	Different radio access technologies and different sizes of small base stations deployed within the coverage of the macro cell.
Interruption time	The shortest period of time during HO where the user equipment is unable to transmit or receive data.
Key performance indicators	The significant indicators of progress to measure the network performance over a certain objective.
Mobility robustness optimization	A self-optimization case that optimizes HO control parameter with minimal human intervention to preserve the connection quality and maintain network resources during the transition of the user equipment from the serving BS to the target BS.
Too early handover	The HO is triggered too early to the target BS causing a short radio link failure after a successful initiation of the HO procedure.
Too late handover	The user equipment's speed is faster than the allowed setting of time-to-trigger which causes a radio link failure at the serving BS due to the location of the user equipment being far away from the serving BS where the signal strength is very low.

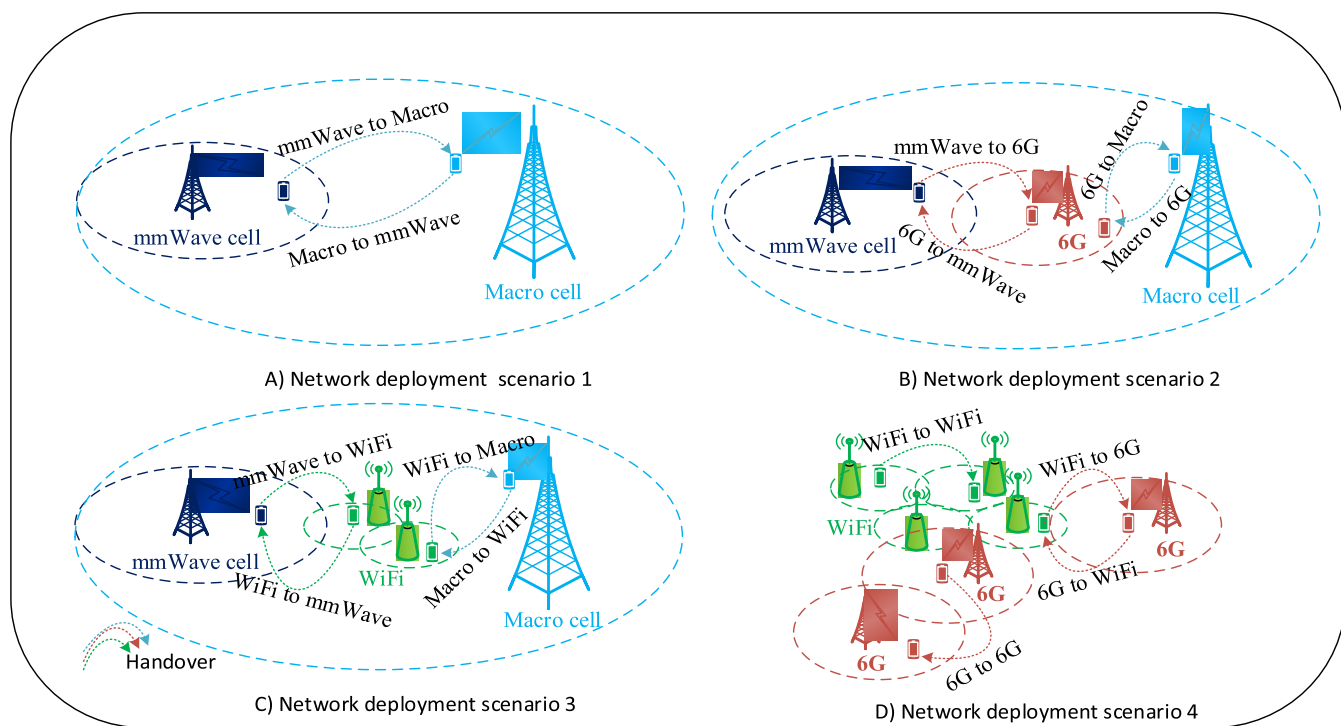

FIGURE 5. Various network topologies and various handover scenarios in future mobile HetNets.

Various solutions have been developed to determine the best selection of target cells and achieve optimal triggering points. Self-optimization of HCPs in HetNets where massive SBSs are deployed may lead to severe degradation in connection quality. However, proposing self-optimized HO algorithms

that can adapt optimal HCPs (HOM and TTT) are essential for system enhancements, especially when HetNets are implemented. The following are studies with diverse algorithms and techniques applied to HO. Each approach presents different accuracies.

A. VELOCITY-AWARE BASED

The speed of UE mobility significantly influences the HO performance of the network. This situation becomes complex within ultra-dense small cell deployments where the network experiences a high probability of frequent HOs. Several studies have investigated different UE speed scenarios. The studies are organized in Table 3 based on the sequence of each study presented as follows.

A statistical HO optimization algorithm in LTE high-speed railway environment (i.e., 360 km/hr) based on HOM and TTT has been proposed in [24]. Due to the complexity of the high-speed railway environment, the RSRP, RSRQ and the rate of cell resource changes have been simultaneously considered to further improve HO triggering. The algorithm considers the RSRQ, reflecting on the harsh channel environment where noise and interference are high. This will cause unnecessary HOs and severe degradation of the system's performance. The authors have introduced a statistical HO triggering for high-speed UE in parallel with traditional A3 event-based HO algorithm. If the user-speed is below 120 km/hr, traditional A3 event-based HO algorithm is applied. If above 120 km/hr, the new HO algorithm will be triggered. The new HO algorithm evaluates the measurement reports to determine whether or not it satisfies the triggering criteria. If satisfied, the statistical values are summed and set to a statistical threshold value. The measurement report is then sent to the serving cell for HO triggering. The algorithm solves the problem of low-speed scenarios structured in the LTE system (i.e., A3 event-based HO algorithm). These are unsuitable algorithms for high-speed railway scenarios. With increasing speeds, several issues concerning system performance may occur such as imbalanced wireless channel environment or severe deterioration of connection quality. The new proposed algorithm enhances system performance by increasing the HO success rate and significantly reducing the number of HOs. The ping-pong ratio is minimized by up to 47% and the HO success rate is 0.5% to 13.9% greater than the traditional A3 algorithm under different speed variations.

Frequent HOs may be caused by channel fading, static or slow-moving users which deteriorate system performance. Especially, high-speed UE within a deployed ultra-dense small cell network may experience high frequent HOs compared to low speed users. These frequent HOs should be properly identified and mitigated. Hasan *et al.* have proposed a Frequent Handover Mitigation (FHM) algorithm based on threshold control parameter to lessen unwanted HOs for ultra-dense HetNets. This is accomplished by detecting frequent HOs experienced by users and classifying them as either fast-moving users or ping-pongs [30]. The proposed algorithm monitors the serving cell history and the dwelling time of users to detect unwanted HOs. If the HO history information repeats the pattern within a very short dwelling time, the algorithm considers the situation as ping-pong. If the HO history information has no repeat pattern within a short dwelling time, the situation is considered as fast-moving users. This proposed algorithm successfully solves the issue of

unnecessary HOs. The FHM algorithm increases network throughput. The proposed algorithm has recorded an enhancement of 10.82% in throughput and 79.56% reduction in overall HOs.

In [32], a velocity-aware HO Self-Optimization Algorithm (SOA) has been proposed based on the UE's speed and RSRP to adapt HOM and TTT in HetNets. The proposed algorithm auto tunes HCPs at four different UE speed scenarios: 40 km/h, 80 km/h, 120 km/h and 160 km/h. The main objective of this research is to achieve the optimum triggering points to reduce the HOP, RLF and HPPP of all UEs in HetNets. The proposed algorithm was simulated using MATLAB in a communication environment consisting of a two-tier model. The model has multiple uniformly distributed SBSs employed within the coverage of the macro cell. The results of the proposed approach exhibited significant reduction in HOP, HPPP and RLF under all UE speeds compared to the conventional speed-based [100] and SINR-based [101] algorithms. The proposed algorithm also achieved a significant reduction of up to 70% in the overall HOP. This study can be extended to a distributed optimization HO for enhancing system performance.

The conventional A3 HO triggering mechanism was designed for low-speed scenarios (i.e., below 120 km/hr). Today, high-speed trains, new cars and unmanned aerial vehicles can move at greater speeds far beyond what has been specified. New HO algorithms which adapt HO parameters (i.e., HOM and TTT) are needed to maintain a seamless connection and keep the system quality above a certain threshold. Zhang *et al.* [33] proposed an HO optimization algorithm to minimize the rate of RLF and HPPP, respectively. The study employed HOM and statistical threshold instead of TTT. The chain structure of eNBs was used along the railway to evaluate the UE's speed scenarios classified as low, medium and high. The simulation results demonstrated that the proposed algorithm could achieve high performance in RLF and HPPP, better than the traditional A3 event. The proposed algorithm can automatically adapt HCPs (TTT and threshold) of the high-speed railway network. System performance can be further improved if adaptive TTT is used in the proposed algorithm since it highly influences system accuracy.

Seamless connection quality in high-speed environments is required for user satisfaction. Providing mobile broadband communication in the railway environment will significantly improve the user's QoE. Davaasambuu *et al.* [34] proposed an HO self-optimization approach that dynamically adjusts the HOM and Cell-Individual Offsets (CIO) based on the UE's velocity, RLF and IT. The mobile relay node was also presented as a communication network structure in the high-speed railway environment. The study illustrated that accurate timing is crucial for initiating HO procedure for optimizing HOM and CIO to reduce the RLF and IT. In [34], the installation of dual mobile relay nodes on the train was proposed. One mobile relay node produces a measurement report (i.e., RSS) which is controlled by the serving cell, while the other triggers HO. Throughout the entire simulation, the

TABLE 3. HO self-optimization based on the UE's speed.

Reference	Scenario	Criteria	HCPs	KPIs	Simulator	Achievements	Considered speed
[24]	LTE Network	- RSRP - RSRQ - Rate of cell - Resources change - UE's speed	- HOM - TTT	- Number of Hos - HO success rate - HPPP	MATLAB	- Improvement in utilizing resources during HO.	Up to 360 Km/hr.
[30]	HetNet	- RSRP - UE's speed	- Threshold	- CDR - HO ratio	NS-3 system	- Monitoring UE's dwelling time. - Enhancement in throughput by 10.82%. - The number of HOs are reduced up to 79.56%.	144 Km/hr.
[32]	HetNet	- RSRP - UE's speed	- Threshold - HOM	- HOP - HPPP - RLF	MATLAB	- 70 % reduction in overall average HOP compared to other algorithms presented.	40, 80, 120, and 160 Km/hr.
[33]	LTE Network	- RSRP - UE's speed	- TTT - HOM	- HOP - HPPP - RLF	MATLAB	- High performance in RLF and HPPP.	120, 250, and 350 Km/hr.
[34]	LTE Network	- RSRP - UE's speed	- HOM - CIO	- RLF - IT	LTE-sim	- High performance in RLF and connection quality compared to other algorithms presented.	Up to 350 Km/hr.
[29]	5G Network	- UE's SINR - UE's traffic - Speed	- TTT - HOM	- RSRP - HOP - HPPP - RLF	MATLAB	- More enhancements in the applied KPIs compared to other algorithms presented.	Low-speed scenarios (i.e., 40, 60, and 80 Km/hr) High-speed scenarios (i.e., 100, 120, and 140 Km/hr).

average number of RLFs was seen to vary between 8 and 13. The IT reduced by 9.8 ms at 200 km/hr, which is sufficient for maintaining the connection quality of users. Since TTT is one of the most essential parameters for HCPs, it must be considered in the algorithm as an additional parameter since it has a significant effect on HO.

The partial optimization of HCP settings leads to suboptimal HO triggering, thereby degrading the overall system performance. Manual optimization, partial investigation of HCPs and central optimizations are the limitations toward achieving optimal HO triggering. To overcome these limitations, each UE will require an individual self-optimization technique for HO. Recently, Shayea *et al.* [29] proposed an individualistic dynamic HO parameter optimization algorithm for 5G networks based on the automatic weight function and input metrics (i.e., UE SINR, UE speed and UE load) to enhance the KPIs (i.e., RSRP, HOP, HPPP and RLF). The automatic settings of TTT and HOM were individually estimated for each UE based on the weight function. The study divided the speed scenarios into low-speed (i.e., 40 km/hr, 60 km/hr and 80 km/hr) and high-speed (i.e., 100 km/hr, 120 km/hr and 140km/hr).

B. HO OPTIMIZATION BASED ON RSRP

Several studies have investigated the RSRP as a solution for solving the HO self-optimization problem in HetNets. These studies are as follows:

Abdulraqeb *et al.* [23] proposed the ATO algorithm for HO optimization which considers the user-speed and RSRP at the same time. The ATO algorithm properly adjusts TTT and HOM, particularly for SBSs implementation. The algorithm was evaluated by simulating a two-tier model within LTE-A and 5G network. Six KPIs have been used in the proposed algorithm: HOP, HPPP, RLF, CDR, HO delay and IT. The KPIs did achieve a significant reduction of more than 80% in the total rate during user mobility compared to other state-of-the-art algorithms, such as the conventional, speed-based [100] and SINR-based [101] algorithms. This algorithm can be further improved by taking into account the traffic load of each cell and the RSRQ.

The distributed robustness optimization algorithm has been proposed to adjust the TTT, CIO and A3 event offset, minimizing the number of HOFs and HPPP [60]. To verify the proposed MRO algorithm, simulations were conducted using NS-3 network simulator with the LTE module. The proposed

solution has been carried out to solve the issues related to RLF. Minimizing the number of HOFs further enhances QoE. The MRO algorithm efficiently finds optimal HO parameters since it can simultaneously optimize three parameters and arbitrate optimization conflicts among HOF classes in a cell. The MRO algorithm also provides the lowest ping-pong rate. If the algorithm investigates HOM, the system may have more HO accuracy.

To reduce the RLF, Song *et al.* [94] proposed a self-optimization scheme where threshold, CIO, and HOM can be tuned. The common system parameters and cell-specific parameters are adjusted together by the proposed scheme for system enhancement. Proper adjustments of HO parameters are done after identifying the types of RLF. The proposed scheme can also modify the level of transmission power according to the adjustments of HO parameters. Power modifications are applied when adjustments of HO parameters are insufficient in reducing RLF. Improper HO timing maximizes the rate of RLF, thereby worsening system performance. Effective HO timing is managed by HO parameters. However, minimizing RLF can be accomplished by controlling HO parameters. The simulation results show a significant reduction in RLF. To improve this algorithm, the UE speed and ping-pong effect should also be included in the proposed scheme.

A Dynamic-HCP (D-HCP) algorithm has been proposed in [103] to address HO Parameter Optimization (HPO) which are TTT and HOM based on HO types (i.e., too early HO, too late HO and wrong cell HO). The D-HCP aims to reduce the RLF and HPPP. The proposed solution has been accomplished to reduce human intervention/manual optimization on the system setting to reduce the cost and efforts for network operators. The system model and simulation parameters of this research are based on 3GPP-specified evaluation methodology. The D-HPO algorithm was analyzed using a two-tier model simulation consisting of 4G and 5G networks. The D-HPO algorithm enhances system performance better than defining a static value for HCPs. The algorithm exhibited improvements in reducing HPPP, the average RLF and HOP compared to the fixed values presented in the literature. However, non-optimized HCPs lead to non-optimal HCP values. Several parameters such as the UE's speed and traffic load of each cell should be presented in the optimization process.

The work addressed in [103] has been extended in [53] using the same proposed algorithm (i.e., D-HCP) to optimize TTT and HOM based on the dominant HOF. The objective of the D-HCP algorithm is to minimize unnecessary HOs, RLF and IT. The proposed algorithm was introduced to the framework of HetNets for accurate evaluation. The algorithm has been verified based on 3GPP evaluation methodology. D-HCPs algorithm auto-tunes TTT and HOM to perform fast HO and to avoid too late HO. The D-HCPs algorithm minimized HPPP by up to 78.31% over the entire simulation. This is considered to be a better outcome compared to the presented algorithm addressed in the literature, introduced as static HCP. The RLF and IT have also been reduced

by 49.86% and 44.94%, respectively, for all mobile speeds. SINR, UE mobile speed and the traffic load of each cell should be included in D-HCP as additional parameters to improve the algorithm's performance. Table 4 organises the studies presented in this section according to their sequence.

C. HO OPTIMIZATION BASED ON FLC

FLC has been considered as a solution for various research, presented as follows:

Silva *et al.* proposed a fuzzy logic-based-threshold according to the RSRP, RSRQ and UE velocity for reducing the effects of HPPP and HOF on system performance [39]. HOM has been used as a HO control parameter for MRO in this study. A dense SBSs environment has been applied in this algorithm. Two macro cells, 200 SBSs and 50 UEs were randomly distributed in the simulation within the deployment scenario area (i.e., 1000m × 1000m). In the simulations, the signal propagation models used for macro cells and SBSs are Okumura-Hata and ITU-R P.1238, respectively. Random waypoint mobility has been used as a model for the movement of UEs. This algorithm decreased the HOF ratio (5% reduction) and HPPP (less than 1%) compared to conventional LTE HO [41] and fuzzy multiple-criteria cell selection [40] presented in the literature.

Improper cell selection during HO may lead to HOF, HPPP, high interference and low bandwidth, consequently degrading the quality connection which influences user satisfaction. Hussein *et al.* proposed an HO optimization method named fuzzy multiple-criteria cell-selection using fuzzy TOPSIS based on TTT and HOM [40]. The proposed algorithm has been evaluated based on RSRP, SINR and the number of resource blocks. HOF, HPPP and throughput are the KPIs applied for system enhancements. The main objective of this study is to find the optimal selection of the target cell to maintain connection quality for UE during HO. The deployment scenario included 19 cells within an area of 1 km². Different UE speed scenarios were considered (i.e., 3 km/hr, 30 km/hr and 120 km/hr) with random direction model. The proposed algorithm was compared with two methods presented in the literature (i.e., conventional and cell selection method). HPPP has been reduced by approximately 27% and 23% compared to the two methods presented. The HOF was also reduced by approximately 19% and 15% over the presented methods. The throughput gain achieved by the proposed algorithm was 11% compared to the conventional method.

The deployment of dense SBSs is considered as a solution to deliver an adequate connection service to a large population. In contrast, this deployment may subsequently cause a large number of unnecessary HOs and HOFs, thereby degrading system performance. Therefore, Silva *et al.* proposed the FLC scheme which utilizes user-speed and radio channel quality to auto-tune HOM [4]. The aim of the proposed algorithm is to minimize unnecessary HO and HOF ratio while exploiting the benefits of deploying a dense SBSs. The proposed algorithm has integrated a traditional HO decision with fuzzy logic for auto-tuning HOM settings. The inputs

TABLE 4. HO self-optimization based on RSRP.

Reference	Scenario	Methodology	HCPs	KPIs	Simulator	Achievement
[23]	HetNet	- RSRP-based	- TTT - HOM	- HOP - HPPP - RLF - CDR - HO delay - IT	MATLAB	The total rate of all performance metrics have been reduced by more than 80% compared to the conventional, speed-based and SINR-based algorithms.
[60]	LTE small BSs	- RSRP-based	- TTT - CIO	- RLF - HPPP	NS-3	Additional improvement in the ping-pong rate compared to the enhanced weighted performance-based HO-parameter optimization [102], adaptive Ocn tuning [63] and fuzzy-based HO optimization [35] algorithms.
[94]	LTE small BSs	- RSRP-based	- Threshold - CIO - HOM	- RLF	NS-2	The RLF reduced more than the hysteresis scheme presented in the literature.
[103]	HetNet	- RSRP-based	- TTT - HOM	- HOF - HPPP	MATLAB	HOF and HPPP have been minimized by the proposed algorithm more than the HO parameter algorithm presented in the literature.
[53]	HetNet	- RSRP-based	- TTT - HOM	- Unnecessary HOs - RLF - IT	MATLAB	Unnecessary HOs, RLF and IT have been reduced by the proposed algorithm compared to the D-HCP [103] algorithm presented in the literature.

TABLE 5. HO self-optimization based on FLC.

Reference	Scenario	Methodology	Criteria	HCPs	KPIs	Simulator	Achievements
[39]	HetNet	FLC	- RSRP - RSRQ - UE's velocity	- HOM	- HPPP - HOF	MATLAB	HOF and HPPP are reduced by less than 1% and 5%, respectively, compared to conventional LTE HO [41] and fuzzy multiple-criteria cell selection [40] presented in the literature.
[40]	LTE – Macro BSs	Fuzzy TOPSIS	- RSRP - SINR - Number of resource blocks	- TTT - HOM	- HPPP - HOF - Throughput	LTE-sim	Significant reduction in HPPP and HOF compared to conventional methods.
[4]	Dense small BSs	FLC	- RSRP - RSRQ	- HOM	- HPPP - HOF	MATLAB	HPPP was minimize d to less than 1%.
[35]	LTE Network	FLC	- RSRP	- TTT - HOM	- CDR - HO ratio - CBR	MATLAB	The network is more sensitive to variations of HOM.
[36]	HetNet	FLC	- UE's SINR - Traffic load - UE's velocity	- TTT - HOM	- HOF - HPPP - RLF	MATLAB	Reduction in HOF, HPPP and RLF.
[38]	LTE-femto cells	FLC	- RSRP	- TTT - HOM	- CDR - HO rate	Dynamic system level	CDR was reduced by up to 25%.

(i.e., RSRP, RSRQ and velocity) have been evaluated by the fuzzy logic system in order to observe their impact on the proposed algorithm. The results show that the HPPP has been reduced to less than 1%. The HOF ratio and the overall HOs have been significantly reduced by the algorithms

presented in the literature. The TTT was not investigated in this study since it is considered as the most essential HCP.

Muñoz *et al.* investigated the potential of adjusting HOM and TTT for HO optimization, including other factors in the

analysis such as the system load and the user-speed [35]. The performance was assessed by measuring CDR, HOR and CBR based on HO parameters. In this study, the FLC was proposed for HO optimization. The suggested solution was used to solve the effects of the mentioned KPIs on system performance. However, these parameters require further enhancements to increase system performance. A dynamic LTE system-level simulator has been developed in MATLAB to perform the sensitivity analysis and assess the FLC performance. FLC was used by inputting KPI (i.e., CDR and HOR). From these KPIs, HOM can be adjusted by the FLC to achieve a good trade-off between the HO signalling load and user QoE. The simulation results of this research show that the network is more sensitive to variations of HOM. Adjusting the TTT does not provide greater benefit than that obtained by adjusting HOM, therefore, tuning HOM would be a simple but effective solution for MRO. Cell-pair-wide optimization provides a stable global indicator since it can adapt to specific radio conditions of each cell pair. The drawback of this research is that the maximum user-speed is set to 50 km/h which is very low, especially when considering the traveling of train/drones at speed of 500 km/hr nowadays.

The Weighted Fuzzy Self-Optimization (WFSO) approach has been proposed based on the SINR ratio, traffic load of serving and target eNBs and the UE velocity [36]. This approach was introduced for optimizing TTT and HOM to minimize RLF and HPPP. The proposed algorithm achieves proper HCP values by obtaining the weight function for each considered parameter as an input in the fuzzy logic system. Proper HCP values for each UE are independently adapted based on three parameters (i.e., user's SINR, traffic load of serving and target BSs and user's speed). As previously stated, massive deployment of SBSs leads to a high number of HOs which may cause HOF and HPPP, subsequently deteriorating connection quality. Self-optimized HO algorithms that can adapt optimal HCPs are required, especially when SBSs are implemented. The results of the proposed approach show a significant reduction in HOF, HPPP and RLF compared to other algorithms addressed in the literature.

Buenestado *et al.* proposed FLC for auto-tuning HOM and TTT of indoor femto cells in the LTE network to enhance system performance [38]. The system was evaluated based on two KPIs, i.e., the CDR and HO rate. The objective is to maintain balance between the signalling traffic created by HOs and CDR which measures user satisfaction. The configuration values of HOM and TTT ranged from 0 to 8 dB and from 100 to 800 ms, respectively. Dynamic system-level simulator was used as a simulation tool in this study. The simulation results demonstrated that CDR reduced by up to 25% compared to other algorithms presented in the literature. The network load was maintained while keeping CDR at an acceptable limit.

The authors in [104] proposed a self-optimization approach to mitigate the cell drop rate based on three functionalities applied (i.e., dynamic neighbouring list optimization, LBO and MRO techniques). All optimization algorithms

have a direct relation in optimizing network resources. The proposed solution solves the issues related to HOF (i.e., too late HO, too early HO and HO to wrong cell). Self-optimizing such problems in SBSs HetNet remains far behind from achieving reliable HO solutions. LBO, dynamic neighbouring list optimization and MRO technique all reduce the cell drop issue during HO.

Throughout the literature, various algorithms and methods with different KPIs were addressed to self-optimize HOs in HetNets. The aim of the applied strategies is to preserve connection quality between the UEs and eNBs during HO. Performance metrics were applied as indicators for network enhancements. These indicators (i.e., HOF, unnecessary HOs, throughput, RLF, CDR, CBR and number of HOs) play a vital role in identifying system accuracy. Enhancing KPIs lead to improvements in system performance. Several studies have investigated the high-speed scenarios of UEs as a critical component in mobility management. Several issues related to system performance may occur when the UE's speed increases, such as unnecessary HOs. HO self-optimization within the deployed ultra-dense small cell networks (i.e., micro cell and femto cells) were extensively evaluated for seamless HO. However, investigations are still far from achieving reliable HO.

Several methods have been applied to solve the HO self-optimization problem in HetNets. ML, FLC and Data-Driven HO Optimization (DDHO) were used for the optimal selection of the target eNB and triggering points. Various types of ML, such as unsupervised ML and reinforcement learning, were also proposed. The K-means clustering algorithm and Q-learning techniques have been further suggested. FLC and statistical HO optimization, in conjunction with ML, were introduced to enhance QoE.

Additional research is still required to achieve more efficient HO SOAs to successfully meet the 5G requirement of supporting ultra-reliable communication. Preserving the connection quality during high mobile speed scenarios (up to 500 km/hr) is still a critical challenge in mobility management. The implementation of mmWaves leads to the increase in the number of HOs since coverage is very small. It requires proper HO SOA to maintain continuous connection during HO. The studies shown have been organized in Table 5 according to the sequence presented in this section.

IV. HANDOVER SELF-OPTIMIZATION CHALLENGES

In recent years, various researches have investigated several challenges related to HO self-optimization in HetNets. These challenges are summarized as follows:

A. CENTRAL OPTIMIZATION

Most studies have analyzed HO self-optimization at eNBs without self-optimizing each user individually. The adapted HCP values are applied for all users during HO. The status of each user during HO is different from other users inside the cell, implying that central HO optimization is a major challenge facing system accuracy. Distributed HO

self-optimization is the way forward to enhance system accuracy since HCPs are dynamically adjusted and assigned to each individual user based on their status [60], [103].

B. PARTIAL SELF-OPTIMIZATION

Previous studies have not examined several essential parameters for HO self-optimization approaches. These parameters, such as TTT and HOM, have a direct impact on system performance. Optimizing one parameter without the other will lead to deteriorated system performance. For significant system enhancement, all control parameters should be considered. Some authors have only investigated their algorithms based on RSRP without including RSRQ as an additional parameter [23], [24], [30]–[34], [63].

C. NON-OPTIMAL HANDOVER SELF-OPTIMIZATION FUNCTION

Manual optimization for future mobile HetNets (i.e., ultra-dense networks) leads to an increase in operational expenditure which is a concern for network operators. Reducing manual operation by applying automatic self-optimization functionalities, such as MRO, are required for system enhancement. An auto tuning network with enhanced quality connection would be essential for future networks. Despite several available self-optimization functions throughout the literature, no optimal function has been obtained. Achieving optimum triggering settings for HOM and TTT by applying HO parameter SOA remains to be a major research issue.

D. SPEED SCENARIOS DURING HANDOVER

With the advancement of the transportation system, maintaining quality connection during high-speed events is a critical challenge in mobility management. Mobility of high-speed railways cause a significant number of frequent HOs. These HOs should be triggered in a very short time interval to preserve connection quality between the UE and eNB. Most research have ignored the high-speed scenarios of UEs where unbalanced wireless channel environment and severe deterioration of connection quality may occur. Although several studies have investigated speed scenarios, further evaluations are still needed to achieve optimal function that effectively handles high-speed scenarios. From previous studies, each high-speed algorithm was unable to optimally function due to implementation drawbacks. These drawbacks have been addressed in related works. The 5G requirements must support very high mobility speeds of up to 500 km/hr. Ensuring reliable communication with these high requirements will demand the implementation of efficient HO SOAs [24], [30]–[34].

E. CONFLICT AMONG FUNCTIONALITIES AND PARAMETERS

The amount of SON functions have increased, yet the contradictions and dependencies between these functions have also risen. Joining more than one function leads to contradictions in their objectives since they use the same metrics as

indicators to measure system performance. MRO and LBO are not stand-alone functions since they both use HOM during adjustments. Using the same KPIs through joint functions with different objectives lead to a monopolization risk by the uppermost priority function. The contradiction between HO parameters requires further investigation to acquire efficient HO SOAs. Solving the issue of too late HO will lead to HPPP since it conflicts with the TTT's time interval. The RLF also requires a reduction in HOM, while HPPP requires an increase in HOM [26], [58], [59]. The previous section has compared the related studies and discussed their pros and cons.

F. DIFFERENT USER EXPERIENCES

Each connected device may experience different mobility statuses, such as in speed and SINR, compared to other devices [23]. Currently, the number of connected devices has dramatically increased. Users require individual optimization based on their user experience to preserve the connection quality of UEs. Optimizing the entire network during HO is an important issue as it may lead to degraded connection quality. Auto-tuning appropriate values for HCPs to each user independently can be accomplished by using deep reinforcement learning techniques.

V. SOLUTIONS FOR HANDOVER SELF-OPTIMIZATION

Several approaches have been proposed to control HO self-optimization. These approaches are summarized as follows:

A. CONVENTIONAL METHODS

Earlier, various conventional algorithms have been applied to optimize HO such as triggering the HO and updating the parameters based on the number of HOF rates over a defined number of HOs. Conventional HO triggering algorithm (i.e., A3 event) facing limitations to deal with high speed (i.e., greater than 120 km/hr) scenarios [33], [100].

B. WEIGHT FUNCTION

Weight functions have been proposed for self-optimizing HCPs in several studies. In addition, the decision to make a HO triggering is based on the weight level of the investigated factor. However, due to a different UE's mobility experience, assigning a static weight values to HO metrics may lead to inaccurate HO triggering [21], [29], [102].

C. MACHINE LEARNING

In the last 10 years, ML has become one of the main solutions to the challenges related to HO self-optimization. It can greatly reduce the complexity of HO functionalities. The combination of various types of ML using different techniques has been proposed to manage HO self-optimization in HetNets.

1) SUPERVISED ML

Supervised ML methods have been applied as solutions in several HO self-optimization research, mainly for MRO algorithms. Neural networks multi-layer perceptron, linear regression, K-nearest neighbour, extreme gradient boosting,

categorical boosting and deep neural network (i.e., rectified linear unit and SoftMax function) have been used as solutions in HO self-optimization (i.e., MRO) [42], [43], [105]–[109].

2) UNSUPERVISED ML

Unsupervised ML, particularly the K-means clustering algorithm and data mining techniques, has been proposed to autonomously learn and identify the characteristic patterns in RSS from users as they approach the cell-edge. It must apply optimal HO parameters for each case. The aim of this approach is to determine the best triggering values of each cluster by matching the current measurement reports with previous clusters. Once the matching occurs, the optimal triggering values are executed based on that specific cluster [45].

3) REINFORCEMENT LEARNING (Q-LEARNING)

Reinforcement learning techniques (more precisely, Q-learning) are widely employed to solve the issues related to HO self-optimization in HetNets. The Q-learning optimization algorithm is used to obtain an effective HO decision by choosing the optimal triggering points of HOM and TTT, thereby maximizing system performance. It is also appropriate for managing the dynamic environment of HetNets [46], [110].

D. FUZZY LOGIC

FLC has been introduced as a potential solution for HO self-optimization in HetNets. The process begins by inputting KPIs to FLC. From these KPIs, HOM and TTT can be adjusted to achieve a good trade-off between the HO signalling load and user experience. Fuzzifier need to be executed to transform the continues inputs into fuzzy sets [4], [35], [36]–[38].

1) WEIGHTED FUZZY SELF-OPTIMIZATION

The WFSO approach has been introduced for optimizing HCPs to minimize the RLF and HPPP. The proposed algorithm achieves optimal HCP values by obtaining a weight function for each parameter considered as an input in the fuzzy logic system [36].

2) FUZZY-AHP

The Fuzzy-AHP scheme selects the best network among all available networks. The optimum network selection will ensure high QoS, thereby enhancing system performance [37].

E. INTEGRATED METHOD WITH Q-LEARNING

1) FUZZY Q-LEARNING

The Q-learning optimization algorithm with FLC (fuzzy Q-learning) have been implemented together in several studies. The fuzzy Q-learning algorithm can achieve optimal HCP values. It can perform joint load balancing by implementing the MRO algorithm to reduce complex functionalities. The fuzzy system adjusts HO parameters to enhance system performance which is then optimized by the Q-learning algorithm to select the most suitable action. The system makes

decisions based on previous actions measured by KPIs [26], [44], [47], [48].

2) Q-LEARNING WITH OTHER TECHNIQUES

The Q-learning optimization algorithm, with the coexistence of several other algorithms (i.e., AHP-TOPSIS), have been investigated to determine the proper setting of optimal triggering points for HOM and TTT [25].

F. STATISTICAL HANDOVER OPTIMIZATION

The statistical approach has been introduced by several researchers to monitor the serving cell history and dwelling time. Statistical HO optimization is a suitable algorithm which can be used in a high-speed railway environment [24]. Based on statistical values, suitable HCPs can be acquired by identifying, analyzing and forwarding data to the KPI estimation engine for HCP optimization. The obtained values are then applied to the related eNB.

G. GAME THEORY AND MULTI-ATTRIBUTES DECISION MAKING TECHNIQUES (MADM)

Game theory techniques have been used as a solution method to select the optimal target BS for HO decision by applying analytical tools [111], [112]. Moreover, they have contributed to solve the issues related to HetNets such as HO traffic load and signalling [113], [114]. In additional, game theory techniques have the network selection capabilities for the vertical HO networks which subsequently may bring stability and reliability to the network [115]. MADM techniques such as enhanced weighted sum method, TOPSIS, simple additive weighting, multiplicative exponent weighting, and grey relation analysis have played an essential role in reducing the network complexity, computational time, HO delay, number of HOs, and selecting the optimal network during HOs [116]–[124].

VI. FUTURE DIRECTIONS

This survey reveals the following areas as potential research directions for establishing efficient HO self-optimization in HetNets.

A. OPTIMAL HO SELF-OPTIMIZATION FUNCTION

To the best of the authors' knowledge, no optimal triggering algorithms exist for HO self-optimization. Determining an ideal HO triggering value for HCPs remains to be a major research problem.

B. ML AS A METHODOLOGY

ML uses a statistical technique that allows the machine to improve within a dynamic environment without being explicitly programmed since it has high interaction capabilities with the environment. By considering deep learning, the ML community can significantly advance towards numerous successful ML tasks. ML is a crucial technology that can be a solution for HO self-optimization to enable the smooth and efficient transition of UE between BSs. Therefore, ML combined with

TABLE 6. List of abbreviations in alphabetical order.

Item	Description
1G	First Generation
2G	Second Generation
3G	Third Generation
3GPP	Third Generation Partnership Project
4G	Fourth Generation
5G	Fifth Generation
AHP	Analytic Hierarchy Process
AHP-TOPSIS	Analytic Hierarchy Process Technique for Order of Preference by Similarity to Ideal Solution
ATO	Auto-Tuning Optimization
BS	Base Station
CBR	Cell Blocking Ratio
CDR	Cell Dropping Ratio
CIO	Cell-Individual Offsets
DC	Dual Connectivity
DDHO	Data-Driven HO Optimization
D-HCP	Dynamic-Handover Control Parameter
ENB	Evolved Node-B
FHM	Frequent Handover Mitigation
FLC	Fuzzy Logic Controller
HCP	Handover Control Parameter
HetNet	Heterogeneous Network
HO	Handover
HOF	Handover Failure
HOM	Handover Margin
HOP	Handover Probability
HPPP	Handover Ping Pong Probability
HOR	Handover Ratio
HPO	Handover Parameter Optimization
IT	Interruption Time
KPI	Key Performance Indicator
LBO	Load Balancing self-Optimization
LTE	Long-Term Evolution
LTE-A	Long-Term Evolution-Advanced
ML	Machine Learning
mmWave	Millimetre Wave
MRO	Mobility Robustness Optimization
MADM	Multi-Attribute Decision Making
QoE	Quality of Experience
QoS	Quality Of Service
RAT	Radio Access Technology
RLF	Radio Link Failure
RSRP	Received Signal Reference Power
RSRQ	Received Signal Reference Quality
RSS	Received Signal Strength
SBS	Small Base Station
SINR	Signal-to-Interference-plus-Noise Ratio
SOA	Self-Optimization Algorithm
SON	Self-Organisation Network
TTT	Time-To-Trigger
UE	User Equipment
WFSO	Weighted Fuzzy Self-Optimization

supervised learning, unsupervised learning, reinforcement learning, deep reinforcement learning, and deep learning has the ability to reduce system complexity for future HetNets.

C. DUAL CONNECTIVITY

Dual Connectivity (DC) allows the UE to be connected to two different eNBs (known as master eNB and secondary eNB) since the DC enables the UE to transmit/receive data simultaneously. Integrating DC with HO self-optimization for future mobile HetNets will have a significant impact on system performance. In DC, the eNBs operate at different carrier frequencies and connected with traditional backhaul links (known as X2 interface, based on LTE terminology, and Xn in the 5G network).

D. CONDITIONAL HANDOVER

Conditional HO is a new solution that enhances the mobility robustness of UEs. The enhancement is accomplished by minimizing the occurrence of HOF during the transition of UEs from one cell to another. Multiple target cells are prepared in advance as candidates for UEs. This will enable the UE to receive the HO command of the next target cell before the UE connection quality becomes degraded [125], [126].

E. DEEP REINFORCEMENT LEARNING

Conventional reinforcement learning algorithms (i.e., Q-learning) have been introduced as a solution in several studies presented in the literature. However, numerous issues have been raised such as the UE's storage of extremely large Q-value tables, slow processing and computations. All combined, these issues significantly deteriorate system performance. To cope with these limitations, deep reinforcement learning is a promising tool to enhance the performance of 5G and beyond systems. It has less memory requirements for storing the model's parameters and can mitigate the slow processing and computation that traditional reinforcement learning algorithms face [127].

F. DATA DRIVEN HANDOVER OPTIMIZATION

Data driven techniques play a significant role in mitigating and optimizing issues related to mobility management. Future wireless networks (i.e., 5G and beyond) require an intelligent HO triggering mechanism to achieve optimal HO decision. These techniques can reduce mobility issues (i.e., too early HOs, too late HOs, HO to the wrong cell, latency, unnecessary HOs and throughput limitations), which subsequently contributes toward achieving optimal HO triggering [42], [43], [128].

VII. CONCLUSION

This study mainly focused on MRO where state-of-the-art algorithms were comprehensively presented from various research outcomes. Studies related to velocity-aware, RSRP-based, and FLC were examined. Moreover, each study addresses the deployment scenario, methodology, HCPs, KPIs, simulator tool, and the achievement. Besides, network topologies were addressed since it has a direct impact on HO performance. In addition, there are a quite number of issues are open for further investigations such as obtaining

an efficient HO algorithm for future mobile HetNets and solving decentralized optimization of UEs during HOs. Furthermore, various solutions regarding MRO were comprehensively discussed as well. Therefore, future directions of HO self-optimization in HetNets were also addressed. HO self-optimization within a deployed ultra-dense small cell network were extensively evaluated for seamless HO, however, investigations are still far behind from achieving reliable HO solutions.

APPENDIX

See Table 6.

REFERENCES

- [1] I. Shayea, M. H. Azmi, T. A. Rahman, M. Ergen, C. T. Han, and A. Arsad, "Spectrum gap analysis with practical solutions for future mobile data traffic growth in Malaysia," *IEEE Access*, vol. 7, pp. 24910–24933, 2019.
- [2] I. Shayea, T. A. Rahman, M. H. Azmi, C. T. Han, and A. Arsad, "Predicting required licensed spectrum for the future considering big data growth," *ETRI J.*, vol. 41, no. 2, pp. 224–234, Apr. 2019.
- [3] P. Jonsson, S. Carson, P. Cerwall, A. Lundvall, and R. Müller, *Ericsson Mobility Report*. Stockholm, Sweden: Ericsson, Jun. 2021.
- [4] K. D. C. Silva, Z. Becvar, and C. R. L. Frances, "Adaptive hysteresis margin based on fuzzy logic for handover in mobile networks with dense small cells," *IEEE Access*, vol. 6, pp. 17178–17189, 2018.
- [5] W. Kim, "Dual connectivity in heterogeneous small cell networks with mmWave backhauls," *Mobile Inf. Syst.*, vol. 2016, pp. 1–15, Jan. 2016.
- [6] B. Rong, X. Qiu, M. Kadoch, S. Sun, and W. Li, *5G Heterogeneous Networks: Self-Organizing and Optimization*. Cham, Switzerland: Springer, 2016.
- [7] R. Antonioli, G. Parente, C. Silva, D. Sousa, E. Rodrigues, T. Maciel, and F. Cavalcanti, "Dual connectivity for LTE-NR cellular networks: Challenges and open issues," *J. Commun. Inf. Syst.*, vol. 33, no. 1, pp. 282–294, 2018.
- [8] X. Zhang, "HetNet optimization," in *LTE Optimization Engineering Handbook*. Hoboken, NJ, USA: Wiley, 2017, pp. 741–751.
- [9] I. Shayea, M. Ergen, M. H. Azmi, S. A. Colak, R. Nordin, and Y. I. Daradkeh, "Key challenges, drivers and solutions for mobility management in 5G networks: A survey," *IEEE Access*, vol. 8, pp. 172534–172552, 2020.
- [10] R. Tiwari and S. Deshmukh, "Analysis and design of an efficient handoff management strategy via velocity estimation in HetNets," *Trans. Emerg. Telecommun. Technol.*, vol. 33, no. 3, Mar. 2022, Art. no. e3642.
- [11] N. Akkari and N. Dimitriou, "Mobility management solutions for 5G networks: Architecture and services," *Comput. Netw.*, vol. 169, Mar. 2020, Art. no. 107082.
- [12] M. F. Tuysuz and R. Trestian, "Energy-efficient vertical handover parameters, classification and solutions over wireless heterogeneous networks: A comprehensive survey," *Wireless Pers. Commun.*, vol. 97, no. 1, pp. 1155–1184, Nov. 2017.
- [13] N. Omhenni, I. Bouabidi, A. Gharsallah, F. Zarai, and M. S. Obaidat, "Smart mobility management in 5G heterogeneous networks," *IET Netw.*, vol. 7, no. 3, pp. 119–128, May 2018.
- [14] *Telecommunication management; Self-Organizing Networks (SON) Policy Network Resource Model (NRM) Integration Reference Point (IRP); Information Service (IS)*, Standard TS 28.627 version 15.0.0 Release 15, 3GPP, 2018.
- [15] *Universal Mobile Telecommunications System (UMTS); LTE; Telecommunication Management; Self-Organizing Networks (SON) Policy Network Resource Model (NRM) Integration Reference Point (IRP); Information Service (IS)*, Standard TS 28.628 version 15.1.0 Release 15, 3GPP, 2019.
- [16] *Digital Cellular Telecommunications System (Phase 2+); Universal Mobile Telecommunications System (UMTS); LTE; Telecommunication Management; Self-Organizing Networks (SON) Policy Network Resource Model (NRM) Integration Reference Point (IRP); Information Service (IS)*, Standard 3GPP TS 32.522 version 11.7.0 Release 11, 3GPP, 2013.
- [17] *LTE; Evolved Universal Terrestrial Radio Access Network (E-UTRAN); Self-Configuring and Self-Optimizing Network (SON) Use Cases and Solutions*, Standard TR 36.902 Version 9.3.1 Release 9, 3GPP, 2011.
- [18] R. Amiri, M. A. Almasi, J. G. Andrews, and H. Mehrpouyan, "Reinforcement learning for self organization and power control of two-tier heterogeneous networks," *IEEE Trans. Wireless Commun.*, vol. 18, no. 8, pp. 3933–3947, Aug. 2019.
- [19] M. Peng, D. Liang, Y. Wei, J. Li, and H.-H. Chen, "Self-configuration and self-optimization in LTE-advanced heterogeneous networks," *IEEE Commun. Mag.*, vol. 51, no. 5, pp. 36–45, May 2013.
- [20] W. Zheng, H. Zhang, X. Chu, and X. Wen, "Mobility robustness optimization in self-organizing LTE femtocell networks," *EURASIP J. Wireless Commun. Netw.*, vol. 2013, no. 1, p. 27, Dec. 2013.
- [21] I. Shayea, M. Ismail, R. Nordin, M. Ergen, N. Ahmad, N. F. Abdullah, A. Alhammedi, and H. Mohamad, "New weight function for adapting handover margin level over contiguous carrier aggregation deployment scenarios in LTE-advanced system," *Wireless Pers. Commun.*, vol. 108, no. 2, pp. 1179–1199, Sep. 2019.
- [22] I. Shayea, M. Ismail, R. Nordin, H. Mohamad, T. A. Rahman, and N. F. Abdullah, "Novel handover optimization with a coordinated contiguous carrier aggregation deployment scenario in LTE-advanced systems," *Mobile Inf. Syst.*, vol. 2016, pp. 1–20, Dec. 2016.
- [23] A. Alhammedi, M. Roslee, M. Y. Alias, I. Shayea, S. Alraih, and K. S. Mohamed, "Auto tuning self-optimization algorithm for mobility management in LTE—A and 5G HetNets," *IEEE Access*, vol. 8, pp. 294–304, 2020.
- [24] F. Yang, H. Deng, F. Jiang, and X. Deng, "Handover optimization algorithm in LTE high-speed railway environment," *Wireless Pers. Commun.*, vol. 84, no. 2, pp. 1577–1589, Sep. 2015.
- [25] T. Goyal and S. Kaushal, "Handover optimization scheme for LTE-advance networks based on AHP-TOPSIS and Q-learning," *Comput. Commun.*, vol. 133, pp. 67–76, Jan. 2019.
- [26] P. Muñoz, R. Barco, and I. de la Bandera, "Load balancing and handover joint optimization in LTE networks using fuzzy logic and reinforcement learning," *Comput. Netw.*, vol. 76, pp. 112–125, Jan. 2015.
- [27] M.-T. Nguyen and S. Kwon, "Geometry-based analysis of optimal handover parameters for self-organizing networks," *IEEE Trans. Wireless Commun.*, vol. 19, no. 4, pp. 2670–2683, Apr. 2020.
- [28] W. K. Saad, I. Shayea, B. J. Hamza, H. Mohamad, Y. I. Daradkeh, and W. A. Jabbar, "Handover parameters optimisation techniques in 5G networks," *Sensors*, vol. 21, no. 15, p. 5202, Jul. 2021.
- [29] I. Shayea, M. Ergen, A. Azizian, M. Ismail, and Y. I. Daradkeh, "Individualistic dynamic handover parameter self-optimization algorithm for 5G networks based on automatic weight function," *IEEE Access*, vol. 8, pp. 214392–214412, 2020.
- [30] M. M. Hasan, S. Kwon, and S. Oh, "Frequent-handover mitigation in ultra-dense heterogeneous networks," *IEEE Trans. Veh. Technol.*, vol. 68, no. 1, pp. 1035–1040, Jan. 2019.
- [31] M. S. N. Ali, A. L. Yusof, N. Ya'acob, M. Ismail, M. A. Zainali, M. Rosdi, and B. A. Bakar, "Handoff optimization in macrocell and femtocell LTE heterogeneous network," *J. Telecommun., Electron. Comput. Eng. (JTEC)*, vol. 9, pp. 45–48, Jun. 2017.
- [32] A. Alhammedi, M. Roslee, M. Y. Alias, I. Shayea, and A. Alquhali, "Velocity-aware handover self-optimization management for next generation networks," *Appl. Sci.*, vol. 10, no. 4, p. 1354, Feb. 2020.
- [33] Y. Zhang, M. Wu, S. Ge, L. Luan, and A. Zhang, "Optimization of time-to-trigger parameter on handover performance in LTE high-speed railway networks," in *Proc. 15th Int. Symp. Wireless Pers. Multimedia Commun.*, Sep. 2012, pp. 251–255.
- [34] B. Davaasambuu, K. Yu, and T. Sato, "Self-optimization of handover parameters for long-term evolution with dual wireless mobile relay nodes," *Future Internet*, vol. 7, no. 4, pp. 196–213, Jun. 2015.
- [35] P. Munoz, R. Barco, and I. D. L. Bandera, "On the potential of handover parameter optimization for self-organizing networks," *IEEE Trans. Veh. Technol.*, vol. 62, no. 5, pp. 1895–1905, Jun. 2013.
- [36] A. Alhammedi, M. Roslee, M. Y. Alias, I. Shayea, S. Alraih, and A. B. Abas, "Advanced handover self-optimization approach for 4G/5G HetNets using weighted fuzzy logic control," in *Proc. 15th Int. Conf. Telecommun. (ConTEL)*, Jul. 2019, pp. 1–6.
- [37] R. Goyal, T. Goyal, S. Kaushal, and H. Kumar, "Fuzzy AHP based technique for handover optimization in heterogeneous network," in *Proc. 2nd Int. Conf. Commun., Comput. Netw.*, 2019, pp. 293–301.
- [38] V. Buenestado, J. M. Ruiz-Aviles, M. Toril, and S. Luna-Ramirez, "Mobility robustness optimization in enterprise LTE femtocells," in *Proc. IEEE 77th Veh. Technol. Conf. (VTC Spring)*, Jun. 2013, pp. 1–5.

- [39] K. C. Silva, Z. Becvar, E. H. S. Cardoso, and C. R. L. Frances, "Self-tuning handover algorithm based on fuzzy logic in mobile networks with dense small cells," in *Proc. IEEE Wireless Commun. Netw. Conf. (WCNC)*, Apr. 2018, pp. 1–6.
- [40] Y. S. Hussein, B. M. Ali, M. F. A. Rasid, A. Sali, and A. M. Mansoor, "A novel cell-selection optimization handover for long-term evolution (LTE) macrocell using fuzzy TOPSIS," *Comput. Commun.*, vol. 73, pp. 22–33, Jan. 2016.
- [41] *Evolved Universal Terrestrial Radio Access (E-UTRA); Radio Resource Control (RRC); Protocol Specification*, Standard 3GPP TS 36.331, 3GPP, Jul. 2011.
- [42] P.-C. Lin, L. F. G. Casanova, and B. K. S. Fatty, "Data-driven handover optimization in next generation mobile communication networks," *Mobile Inf. Syst.*, vol. 2016, pp. 1–11, Jul. 2016.
- [43] S. Kumari and B. Singh, "Data-driven handover optimization in small cell networks," *Wireless Netw.*, vol. 25, no. 8, pp. 5001–5009, Nov. 2019.
- [44] A. Klein, N. P. Kuruvatti, J. Schneider, and H. D. Schotten, "Fuzzy Q-learning for mobility robustness optimization in wireless networks," in *Proc. IEEE Globecom Workshops (GC Wkshps)*, Dec. 2013, pp. 76–81.
- [45] A. Abdelmohsen, M. Abdelwahab, M. Adel, M. S. Darweesh, and H. Mostafa, "LTE handover parameters optimization using Q-learning technique," in *Proc. IEEE 61st Int. Midwest Symp. Circuits Syst. (MWSCAS)*, Aug. 2018, pp. 194–197.
- [46] D. Castro-Hernandez and R. Paranjape, "Optimization of handover parameters for LTE/LTE-A in-building systems," *IEEE Trans. Veh. Technol.*, vol. 67, no. 6, pp. 5260–5273, Jun. 2018.
- [47] R. D. Hegazy, O. A. Nasr, and H. A. Kamal, "Optimization of user behavior based handover using fuzzy Q-learning for LTE networks," *Wireless Netw.*, vol. 24, no. 2, pp. 481–495, Feb. 2018.
- [48] J. Wu, J. Liu, Z. Huang, and S. Zheng, "Dynamic fuzzy Q-learning for handover parameters optimization in 5G multi-tier networks," in *Proc. Int. Conf. Wireless Commun. Signal Process. (WCSP)*, Oct. 2015, pp. 1–5.
- [49] I. Shayea, T. A. Rahman, M. H. Azmi, and M. R. Islam, "Real measurement study for rain rate and rain attenuation conducted over 26 GHz microwave 5G link system in Malaysia," *IEEE Access*, vol. 6, pp. 19044–19064, 2018.
- [50] I. Shayea, L. A. Nissirat, M. A. Nisirat, A. Alsamawi, T. A. Rahman, M. H. Azmi, M. Abo-Zeed, and I. Trrad, "Rain attenuation and worst month statistics verification and modeling for 5G radio link system at 26 GHz in Malaysia," *Trans. Emerg. Telecommun. Technol.*, vol. 30, no. 12, Dec. 2019, Art. no. e3697.
- [51] I. Shayea, T. Abd. Rahman, M. Hadri Azmi, and A. Arsad, "Rain attenuation of millimetre wave above 10 GHz for terrestrial links in tropical regions," *Trans. Emerg. Telecommun. Technol.*, vol. 29, no. 8, Aug. 2018, Art. no. e3450.
- [52] A. M. Al-Samman, T. A. Rahman, M. H. Azmi, and I. Shayea, "Path loss model and channel capacity for UWB-MIMO channel in outdoor environment," *Wireless Pers. Commun.*, vol. 107, no. 1, pp. 271–281, 2019.
- [53] A. Abdurraqeb, R. Mardeni, A. M. Yusoff, S. Ibraheem, and A. Saddam, "Self-optimization of handover control parameters for mobility management in 4G/5G heterogeneous networks," *Autom. Control Comput. Sci.*, vol. 53, no. 5, pp. 441–451, Sep. 2019.
- [54] S. Shao, G. Liu, A. Khreishah, M. Ayyash, H. Elgala, T. D. C. Little, and M. Rahaim, "Optimizing handover parameters by Q-Learning for heterogeneous radio-optical networks," *IEEE Photon. J.*, vol. 12, no. 1, pp. 1–15, Feb. 2020.
- [55] M. L. Mari-Altozano, S. S. Mwanje, S. L. Ramirez, M. Toril, H. Sanneck, and C. Gijon, "A service-centric Q-learning algorithm for mobility robustness optimization in LTE," *IEEE Trans. Netw. Service Manage.*, vol. 18, no. 3, pp. 3541–3555, Sep. 2021.
- [56] T. M. Duong and S. Kwon, "Vertical handover analysis for randomly deployed small cells in heterogeneous networks," *IEEE Trans. Wireless Commun.*, vol. 19, no. 4, pp. 2282–2292, Apr. 2020.
- [57] H. Fourati, R. Maaloul, L. Chaari, and M. Jmaiel, "Comprehensive survey on self-organizing cellular network approaches applied to 5G networks," *Comput. Netw.*, vol. 199, Nov. 2021, Art. no. 108435.
- [58] P. Muñoz, R. Barco, and S. Fortes, "Conflict resolution between load balancing and handover optimization in LTE networks," *IEEE Commun. Lett.*, vol. 18, no. 10, pp. 1795–1798, Oct. 2014.
- [59] Z. Liu, P. Hong, K. Xue, and M. Peng, "Conflict avoidance between mobility robustness optimization and mobility load balancing," in *Proc. IEEE Global Telecommun. Conf. (GLOBECOM)*, Dec. 2010, pp. 1–5.
- [60] M. T. Nguyen, S. Kwon, and H. Kim, "Mobility robustness optimization for handover failure reduction in LTE small-cell networks," *IEEE Trans. Veh. Technol.*, vol. 67, no. 5, pp. 4672–4676, May 2018.
- [61] Z. Wei, "Mobility robustness optimization based on UE mobility for LTE system," in *Proc. Int. Conf. Wireless Commun. Signal Process. (WCSP)*, Oct. 2010, pp. 1–5.
- [62] Y. Watanabe, H. Sugahara, Y. Matsunaga, and K. Hamabe, "Inter-eNB coordination-free algorithm for mobility robustness optimization in LTE HetNet," in *Proc. IEEE 77th Veh. Technol. Conf. (VTC Spring)*, Jun. 2013, pp. 1–5.
- [63] K. Kitagawa, T. Kamine, T. Yamamoto, and S. Konishi, "A handover optimization algorithm with mobility robustness for LTE systems," in *Proc. IEEE 22nd Int. Symp. Pers., Indoor Mobile Radio Commun.*, Sep. 2011, pp. 1647–1651.
- [64] Y. Lee, B. Shin, J. Lim, and D. Hong, "Effects of time-to-trigger parameter on handover performance in SON-based LTE systems," in *Proc. 16th Asia-Pacific Conf. Commun. (APCC)*, Oct. 2010, pp. 492–496.
- [65] M. S. I. Khan, M. M. Rahman, K. Raahemifar, J. Mistic, and V. B. Mistic, "Self-optimizing control parameters for minimizing ping-pong handover in long term evolution (LTE)," in *Proc. 27th Biennial Symp. Commun. (QBSC)*, Jun. 2014, pp. 118–122.
- [66] Y.-W. Mal, J.-L. Chen, and H.-K. Lin, "Mobility robustness optimization based on radio link failure prediction," in *Proc. 10th Int. Conf. Ubiquitous Future Netw. (ICUFN)*, Jul. 2018, pp. 454–457.
- [67] X. Yan, N. Mani, and Y. A. Sekercioglu, "A traveling distance prediction based method to minimize unnecessary handovers from cellular networks to WLANs," *IEEE Commun. Lett.*, vol. 12, no. 1, pp. 14–16, Jan. 2008.
- [68] F. Zhu and J. McNair, "Optimizations for vertical handoff decision algorithms," in *Proc. IEEE Wireless Commun. Netw. Conf.*, Mar. 2004, pp. 867–872.
- [69] A. Hasswa, N. Nasser, and H. Hassanein, "Tramcar: A context-aware cross-layer architecture for next generation heterogeneous wireless networks," in *Proc. IEEE Int. Conf. Commun.*, Jun. 2006, pp. 240–245.
- [70] C. Chi, X. Cai, R. Hao, and F. Liu, "Modeling and analysis of handover algorithms," in *Proc. IEEE GLOBECOM Global Telecommun. Conf.*, Nov. 2007, pp. 4473–4477.
- [71] R. Tawil, G. Pujolle, and O. Salazar, "A vertical handoff decision scheme in heterogeneous wireless systems," in *Proc. VTC Spring IEEE Veh. Technol. Conf.*, May 2008, pp. 2626–2630.
- [72] J. Madaan and I. Kashyap, "A novel handoff necessity estimation approach based on travelling distance," *Int. J. Intell. Syst. Appl.*, vol. 12, no. 1, p. 46, 2018.
- [73] B. Ma, B. Yang, Y. Zhu, and J. Zhang, "Context-aware proactive 5G load balancing and optimization for urban areas," *IEEE Access*, vol. 8, pp. 8405–8417, 2020.
- [74] R. Kwan, R. Arnott, R. Paterson, R. Trivisonno, and M. Kubota, "On mobility load balancing for LTE systems," in *Proc. IEEE 72nd Veh. Technol. Conf. (Fall)*, Sep. 2010, pp. 1–5.
- [75] J. Suga, Y. Kojima, and M. Okuda, "Centralized mobility load balancing scheme in LTE systems," in *Proc. 8th Int. Symp. Wireless Commun. Syst.*, Nov. 2011, pp. 306–310.
- [76] K. Addali and M. Kadoch, "Enhanced mobility load balancing algorithm for 5G small cell networks," in *Proc. IEEE Can. Conf. Electr. Comput. Eng. (CCECE)*, May 2019, pp. 1–5.
- [77] M. M. Hasan, S. Kwon, and J.-H. Na, "Adaptive mobility load balancing algorithm for LTE small-cell networks," *IEEE Trans. Wireless Commun.*, vol. 17, no. 4, pp. 2205–2217, Apr. 2018.
- [78] P. Muñoz, R. Barco, and I. de la Bandera, "Optimization of load balancing using fuzzy Q-learning for next generation wireless networks," *Expert Syst. Appl.*, vol. 40, no. 4, pp. 984–994, Mar. 2013.
- [79] S. Oh, H. Kim, and Y. Kim, "User mobility impacts to mobility load balancing for self-organizing network over LTE system," in *Proc. 14th Int. Conf. Adv. Trends Radioelectronics, Telecommun. Comput. Eng. (TCSET)*, Feb. 2018, pp. 1082–1086.
- [80] S. Oh, H. Kim, J. Na, Y. Kim, and S. Kwon, "Mobility load balancing enhancement for self-organizing network over LTE system," in *Internet of Things, Smart Spaces, and Next Generation Networks and System*. Cham, Switzerland: Springer, 2016, pp. 205–216.
- [81] S. A. Hashemi and H. Farrokhi, "Mobility robustness optimization and load balancing in self-organized cellular networks: Towards cognitive network management," *J. Intell. Fuzzy Syst.*, vol. 38, no. 3, pp. 3285–3300, Mar. 2020.

- [82] *Universal Mobile Telecommunications System (UMTS); LTE; Telecommunication Management; Self-Organizing Networks (SON) Policy Network Resource Model (NRM) Integration Reference Point (IRP); Requirements*, Standard 3GPP TS 28.627 version 16.0.0 Release 16, 3GPP, 2020.
- [83] J.-H. Bang, S. Oh, K. Kang, and Y.-J. Cho, "A Bayesian regression based LTE-R handover decision algorithm for high-speed railway systems," *IEEE Trans. Veh. Technol.*, vol. 68, no. 10, pp. 10160–10173, Oct. 2019.
- [84] D. Xenakis, N. Passas, L. Merakos, and C. Verikoukis, "Mobility management for femtocells in LTE-advanced: Key aspects and survey of handover decision algorithms," *IEEE Commun. Surveys Tuts.*, vol. 16, no. 1, pp. 64–91, 1st Quart., 2014.
- [85] G. Mahardhika, M. Ismail, and R. Nordin, "Vertical handover decision algorithm using multicriteria metrics in heterogeneous wireless network," *J. Comput. Netw. Commun.*, vol. 2015, pp. 1–8, Jan. 2015.
- [86] I. El Fachtali, R. Saadane, and M. ElKoutbi, "Vertical handover decision algorithm using ants' colonies for 4G heterogeneous wireless networks," *J. Comput. Netw. Commun.*, vol. 2016, pp. 1–15, Jan. 2016.
- [87] X. Yan, Y. A. Şekerioğlu, and S. Narayanan, "A survey of vertical handover decision algorithms in fourth generation heterogeneous wireless networks," *Comput. New.*, vol. 54, pp. 1848–1863, Feb. 2010.
- [88] H. Liao, L. Tie, and Z. Du, "A vertical handover decision algorithm based on fuzzy control theory," in *Proc. 1st Int. Multi-Symposiums Comput. Comput. Sci. (IMSCCS)*, Jun. 2006, pp. 309–313.
- [89] M. Kassar, B. Kervella, and G. Pujolle, "An overview of vertical handover decision strategies in heterogeneous wireless networks," *Comput. Commun.*, vol. 31, no. 10, pp. 2607–2620, Jun. 2008.
- [90] B. Jeong, S. Shin, I. Jang, N. W. Sung, and H. Yoon, "A smart handover decision algorithm using location prediction for hierarchical macro/femto-cell networks," in *Proc. IEEE Veh. Technol. Conf. (VTC Fall)*, Sep. 2011, pp. 1–5.
- [91] R. Ahmad, E. A. Sundararajan, N. E. Othman, and M. Ismail, "Handover in LTE-advanced wireless networks: State of art and survey of decision algorithm," *Telecommun. Syst.*, vol. 66, no. 3, pp. 533–558, 2017.
- [92] S. K. Kim, C. G. Kang, and K. S. Kim, "A adaptive handover decision algorithm based on the estimating mobility from signal strength measurements," in *Proc. IEEE 60th Veh. Technol. Conf. (VTC-Fall)*, Sep. 2004, pp. 1004–1008.
- [93] *LTE; Evolved Universal Terrestrial Radio Access (E-UTRA); Radio Resource Control (RRC); Protocol Specification*, Standard TS 36.331 version 16.4.0 Release 16, 3GPP, 2021.
- [94] M.-H. Song, S.-H. Moon, and S.-J. Han, "Self-optimization of handover parameters for dynamic small-cell networks," *Wireless Commun. Mobile Comput.*, vol. 15, no. 11, pp. 1497–1517, Aug. 2015.
- [95] H.-C. Jang and K.-S. Chang, "A study on handover mechanism in 5G non-standalone network," in *Proc. Int. Comput. Symp. (ICS)*, Dec. 2020, pp. 7–12.
- [96] W. Huang, H. Zhang, and M. Zhou, "Analysis of handover probability based on equivalent model for 3D UAV networks," in *Proc. IEEE 30th Annu. Int. Symp. Pers., Indoor Mobile Radio Commun. (PIMRC)*, Sep. 2019, pp. 1–6.
- [97] K. Vasudeva, M. Simsek, D. López-Pérez, and I. Güvenç, "Analysis of handover failures in heterogeneous networks with fading," *IEEE Trans. Veh. Technol.*, vol. 66, no. 7, pp. 6060–6074, Jul. 2017.
- [98] K.-N. Park, B.-M. Cho, K.-J. Park, and H. Kim, "Optimal coverage control for net-drone handover," in *Proc. 7th Int. Conf. Ubiquitous Future Netw.*, Jul. 2015, pp. 97–99.
- [99] A. Ometov, G. Fodor, D. Moltchanov, L. Militano, S. Andreev, O. N. Yilmaz, T. Tirronen, J. Torsner, G. Araniti, and A. Iera, "Effects of heterogeneous mobility on D2D- and drone-assisted mission-critical MTC in 5G," *IEEE Commun. Mag.*, vol. 55, no. 2, pp. 79–87, Feb. 2017.
- [100] R. P. Ray and L. Tang, "Hysteresis margin and load balancing for handover in heterogeneous network," *Int. J. Future Comput. Commun.*, vol. 4, p. 231, Aug. 2015.
- [101] S. Nie, D. Wu, M. Zhao, X. Gu, L. Zhang, and L. Lu, "An enhanced mobility state estimation based handover optimization algorithm in LTE—A self-organizing network," in *Proc. ANT/SEIT*, 2015, pp. 270–277.
- [102] I. M. Bälän, B. Sas, T. Jansen, I. Moerman, K. Spaey, and P. Demeester, "An enhanced weighted performance-based handover parameter optimization algorithm for LTE networks," *EURASIP J. Wireless Commun. Netw.*, vol. 2011, no. 1, pp. 1–11, Dec. 2011.
- [103] A. Alhammadi, M. Roslee, M. Y. Alias, I. Shayeaa, and S. Alraih, "Dynamic handover control parameters for LTE—A/5G mobile communications," in *Proc. Adv. Wireless Opt. Commun. (RTUWO)*, Nov. 2018, pp. 39–44.
- [104] D. Mishra and A. Mishra, "Self-optimization in LTE: An approach to reduce call drops in mobile network," in *Proc. Int. Conf. Futuristic Trends Netw. Commun. Technol.*, Feb. 2018, pp. 382–395.
- [105] B. Shubyn and T. Maksymyuk, "Intelligent handover management in 5G mobile networks based on recurrent neural networks," in *Proc. 3rd Int. Conf. Adv. Inf. Commun. Technol. (AICT)*, Jul. 2019, pp. 348–351.
- [106] J. Shodamola, U. Masood, M. Manalastas, and A. Imran, "A machine learning based framework for KPI maximization in emerging networks using mobility parameters," 2020, *arXiv:2005.01474*.
- [107] Z. Ali, M. Miozzo, L. Giupponi, P. Dini, S. Denic, and S. Vassaki, "Recurrent neural networks for handover management in next-generation self-organized networks," in *Proc. IEEE 31st Annu. Int. Symp. Pers., Indoor Mobile Radio Commun.*, Aug. 2020, pp. 1–6.
- [108] Z.-H. Huang, Y.-L. Hsu, P.-K. Chang, and M.-J. Tsai, "Efficient handover algorithm in 5G networks using deep learning," in *Proc. GLOBECOM IEEE Global Commun. Conf.*, Dec. 2020, pp. 1–6.
- [109] B. Shubyn, N. Lutsiv, O. Syrotynskyi, and R. Kolodii, "Deep learning based adaptive handover optimization for ultra-dense 5G mobile networks," in *Proc. IEEE 15th Int. Conf. Adv. Trends Radioelectronics, Telecommun. Comput. Eng. (TCSET)*, Feb. 2020, pp. 869–872.
- [110] M.-T. Nguyen and S. Kwon, "Machine learning–based mobility robustness optimization under dynamic cellular networks," *IEEE Access*, vol. 9, pp. 77830–77844, 2021.
- [111] Z. Yi, D. Jiang, L. Cao, and X. Du, "A handover decision algorithm based on evolutionary game theory for space-ground integrated network," in *Proc. Int. Conf. Wireless Commun., Netw. Multimedia Eng. (WCNME)*, 2019, pp. 143–146.
- [112] P. Goyal, D. Lobiyal, and C. Katti, "Game theory for vertical handoff decisions in heterogeneous wireless networks: A tutorial," in *Advanced Computational and Communication Paradigms*, vol. 475. Singapore: Springer, Jun. 2018, pp. 422–430, doi: 10.1007/978-981-10-8240-5_47.
- [113] S. B. Peddi and S. R. Patil, "Game theory based vertical handoff decision model for media independent handover in heterogeneous wireless networks," in *Proc. Int. Conf. Wireless Commun., Signal Process. Netw. (WiSPNET)*, Mar. 2016, pp. 719–724.
- [114] M. Li, X. Xu, Y. Wang, and R. Zhang, "Game theory based load balancing in small cell heterogeneous networks," in *Proc. Int. Conf. Connected Vehicles Expo. (ICCVE)*, Oct. 2015, pp. 26–31.
- [115] P. K. Goyal and P. Singh, "Two-stage non-cooperative game model for vertical handoffs in heterogeneous wireless networks," in *Cloud-Based Big Data Analytics in Vehicular Ad-Hoc Network*. Hershey, PA, USA: IGI Global, 2021, pp. 90–114.
- [116] M. Mansouri and C. Leghris, "The use of MADM methods in the vertical handover decision making context," in *Proc. Int. Conf. Wireless Netw. Mobile Commun. (WINCOM)*, Nov. 2017, pp. 1–6.
- [117] G. A. Preethi, P. Gauthamarayathirumal, and C. Chandrasekar, "Vertical handover analysis using modified MADM method in LTE," *Mobile Netw. Appl.*, vol. 24, no. 4, pp. 1139–1151, Aug. 2019.
- [118] S. Baghla and S. Bansal, "VIKOR MADM based optimization method for vertical handover in heterogeneous networks," *Adv. Syst. Sci. Appl.*, vol. 18, pp. 90–110, 2018.
- [119] S. Driouache, N. Naja, and A. Jamali, "Rank average for handover decision making in heterogeneous wireless networks," *ICST Trans. Mobile Commun. Appl.*, vol. 3, no. 9, Jan. 2018, Art. no. 153555.
- [120] M. Alhabo, L. Zhang, and N. Nawaz, "Hybrid weighted multiple attribute decision making handover method for heterogeneous networks," *Int. J. Electron. Commun. Eng.*, vol. 15, no. 8, pp. 305–311, 2021.
- [121] N. Alias, M. N. M. M. Noor, M. T. Ismail, and M. N. Ismail, "An overview of multi-attribute decision making (MADM) vertical handover using systematic mapping," *J. Telecommun., Electron. Comput. Eng.*, vol. 10, pp. 93–98, Jul. 2018.
- [122] M. Yadollahi, V. T. Vakili, M. Ghaseminajm, and A. Jafarian, "Reducing processing delay and ping pong impact of multi attribute decision making handover for heterogeneous wireless networks," in *Proc. 12th Int. Conf. Telecommun. Modern Satell., Cable Broadcast. Services (TELSIKS)*, Oct. 2015, pp. 365–368.
- [123] M. Mansouri, C. Leghris, and A. Bekkhoucha, "Towards a better combination of the MADM algorithms for the vertical handover optimization in a mobile network multi-access environment," in *Proc. 10th Int. Conf. Intell. Systems: Theories Appl. (SITA)*, Oct. 2015, pp. 1–5.
- [124] S. Goutam, S. Unnikrishnan, and A. Karandikar, "Algorithm for vertical handover using multi attribute decision making techniques," in *Proc. IEEE Int. Conf. Commun., Netw. Satell. (Comnetsat)*, Dec. 2020, pp. 306–313.

- [125] H. Martikainen, I. Viering, A. Lobinger, and T. Jokela, "On the basics of conditional handover for 5G mobility," in *Proc. IEEE 29th Annu. Int. Symp. Pers., Indoor Mobile Radio Commun. (PIMRC)*, Sep. 2018, pp. 1–7.
- [126] C. Lee, H. Cho, S. Song, and J.-M. Chung, "Prediction-based conditional handover for 5G mm-wave networks: A deep-learning approach," *IEEE Veh. Technol. Mag.*, vol. 15, no. 1, pp. 54–62, Mar. 2020.
- [127] Z. Xiong, Y. Zhang, D. Niyato, R. Deng, P. Wang, and L. Wang, "Deep reinforcement learning for mobile 5G and beyond: Fundamentals, applications, and challenges," *IEEE Veh. Technol. Mag.*, vol. 14, no. 2, pp. 44–52, Jun. 2019.
- [128] Z.-Y. Wu, M. Ismail, and E. Serpedin, "Data-driven smart handover in mobile RF/optical HetNets," in *Proc. IEEE 10th Int. Conf. Intell. Syst. (IS)*, Aug. 2020, pp. 322–327.



WAHEEB TASHAN received the B.Sc. and M.Sc. degrees in communication engineering from International Islamic University Malaysia (IIUM), Malaysia, in 2013 and 2017, respectively. He is currently pursuing the Ph.D. degree in electronics and communication engineering with Kocaeli University, Turkey. He is also a TÜBİTAK Researcher at the Department of Electronics and Communications Engineering, Faculty of Electrical and Electronics Engineering, Istanbul Technical University (ITU), Istanbul, Turkey. He has authored/coauthored several articles related to radio propagation. His research interests include mobility management, handover, LTE/LTE-A, radio propagation, indoors and outdoors wireless communication, the Internet of Things (IoT), 5G, and 6G.



IBRAHEEM SHAYEA received the bachelor's degree in electronics and communication engineering from the Faculty of Engineering, University of Diyala, in July 2004, and the master's degree in communication and computer engineering and the Ph.D. degree in electrical and electronic engineering, specifically in wireless communication systems from the Department of Electrical, Electronic Engineering, Faculty of Engineering and Built Environment, Universiti Kebangsaan Malaysia (UKM), in July 2010 and December 2015, respectively. From January 2005 to June 2006, he worked as a Computer and Electronic Maintenance Engineer. From July 2006 to February 2007, he worked as a Maintenance Manager at the Computer and Research Center (CRC), Yemen. From January 2011 to December 2015 (during his Ph.D. study), he worked as a Research Assistant and Demonstrator at the Department of Electrical, Electronic Engineering, Faculty of Engineering and Built Environment, UKM. From January 2016 to June 2018, he worked as a Postdoctoral Fellow at the Wireless Communication Center (WCC), University of Technology Malaysia (UTM). From September 2018 to August 2019, he worked as a Researcher Fellow at Istanbul Technical University (ITU), Istanbul, Turkey. Since September 2019, he has been working as an Associate Researcher with the Department of Electronics and Communication Engineering, Faculty of Electrical and Electronics Engineering, ITU. He is teaching courses for master's and bachelor's students. He is running research projects with postdoctoral researchers, Ph.D., and master's students. He has published several scientific research journals, conference papers, and whitepapers. His research interests include mobility management in future heterogeneous (4G, 5G, and 6G) networks, mobile edge computing, machine, and deep learning, the Internet of Things (IoT), propagation of millimetre-wave, mobile broadband technology and future data traffic growth, and spectrum gap analysis.



SULTAN ALDIRMAZ-COLAK received the B.S. degree in electronics and communications engineering from Kocaeli University, Kocaeli, Turkey, in 2004, and the M.S. and Ph.D. degrees from Yıldız Technical University (YTU), Istanbul, in 2006 and 2012, respectively. She was a Visiting Research Scholar with the Department of Electrical and Computer Engineering, University of South Florida, for the Spring and Summer, in 2009. She is currently an Associate Professor with the Department of Electronics and Communication Engineering, Kocaeli University. Her primary research interests include 5G systems, HETNET, MIMO systems, index modulation, and visible light communications.



MUSTAFA ERGEN received the B.S. degree (Hons.) in electrical engineering as valedictorian from ODTU, the M.A. degree in international studies, the M.S. degree in electrical engineering, and the Ph.D. degree from the University of California (UC) Berkeley, and MOT Program from HAAS Business School. He is currently a Professor with Istanbul Technical University. Previously, he is the Co-Founded Silicon Valley startup WiChorus Inc., focusing 4G technologies and company is acquired by Tellabs [now Coriant]. He was earlier a National Semiconductor Fellow [now TI] at the University of California Berkeley, where he co-founded the Distributed Sensing Laboratory, focusing on statistical sensor intelligence and vehicular communication. He is also the Founder of venture funded Ambeent Inc., focusing on 5G WiFi and AI. He has more than 40 patent applications, many publications, and authored three books, such as *Mobile Broadband* and *Multi-Carrier Digital Communications* (Springer) are about wireless communications. Last one about entrepreneurship *Girişimci Kapital: Silikon Vadisi Tarihi ve Startup Ekonomisi* (Alfa).



MARWAN HADRI AZMI received the B.Eng. degree (Hons.) in electrical and telecommunications from Universiti Teknologi Malaysia, in 2003, the M.Sc. degree in communications and signal processing from the Imperial College of Science, Technology and Medicine, University of London, in 2005, and the Ph.D. degree from the University of New South Wales, Australia, in 2012. He is currently a Senior Lecturer at the Wireless Communication Centre, Universiti Teknologi Malaysia. From 2012 to 2014, he spent his Sabbatical leave of absence at the McGill University, Canada, working in the funded project by RIM Inc. and NSERC, entitled "Cooperative Spectrum Sensing and Information Relaying in Cognitive Wireless Communications." His research interests include mobile and wireless communications, communication theory, error control coding, relay networks, spectrum sensing for cognitive radio, and iterative receiver.



ABDULRAQEB ALHAMMADI received the B.Eng. degree in electronic majoring in telecommunications, and the M.S. and Ph.D. degrees in wireless communication from Multimedia University, Malaysia, in 2011, 2015, and 2020, respectively. From 2012 to 2019, he served as a Research Assistant and a Research Scholar at Multimedia University. He is the author of more than 20 papers in international journals and conferences. His main research interests include heterogeneous networks, mobility management, D2D communication, cognitive radio networks, localization, and propagation modeling. He is a member of professional institutes and societies, such as IEICE, IACSIT, and IAENG. He is also a member of program committees at international conferences and workshops. He was a recipient of several awards, including the Excellent Researcher Award from Multimedia University, in 2019.

...