

Received March 1, 2022, accepted March 14, 2022, date of publication March 16, 2022, date of current version March 24, 2022.

Digital Object Identifier 10.1109/ACCESS.2022.3160215

Survey on Device to Device (D2D) Communication for 5GB/6G Networks: Concept, Applications, Challenges, and Future Directions

MOHAMMED SALIH MOHAMMED GISMALLA^{1,2,3}, (Senior Member, IEEE),
ASRUL IZAM AZMI^{1,2}, (Member, IEEE), **MOHD RASHIDI BIN SALIM**^{1,2}, (Member, IEEE),
MOHAMMAD FAIZ LIEW ABDULLAH^{1,4}, (Senior Member, IEEE), **FARABI IQBAL**^{1,2},
WAFI A. MABROUK^{1,4}, (Graduate Student Member, IEEE),
MAISARA BINTI OTHMAN⁴, (Member, IEEE), **ADEL Y. I. ASHYAP**^{1,4},
AND ABU SAHMAH MOHD SUPA'AT^{1,2}

¹School of Electrical Engineering, Faculty of Engineering, Universiti Teknologi Malaysia, Skudai 81310, Malaysia

²Lightwave Communications Research Group (LCRG), Innovative Engineering Research Alliance, Universiti Teknologi Malaysia, Johor Bahru 81310, Malaysia

³Department of Electronics and Electrical Engineering, Faculty of Engineering, International University of Africa, Khartoum 12223, Sudan

⁴Department of Communication Engineering, Faculty of Electrical and Electronic Engineering, Universiti Tun Hussein Onn Malaysia (UTHM), Parit Raja, Batu Pahat, Johor 86400, Malaysia

Corresponding authors: Mohammed Salih Mohammed Gismalla (salihmohammed@utm.my) and Abu Sahmah Mohd Supa'at (abus@utm.my)

This work was supported in part by the Research Management Centre (RMC), Universiti Teknologi Malaysia (UTM), Malaysia, under the Professional Development Research University Grant 05E69; and in part by UTM under TDR Grant 05G27.

ABSTRACT Device-to-device (D2D) communication is one of the most promising technologies in wireless cellular networks that can be employed to improve spectral and energy efficiency, increase data rates, and reduce links latency. This paper investigates fifth generation and beyond (5GB) networks, the basics of D2D communication, applications, and classification. Herein, D2D in in-band (IBD) and out-band (OBD) modes are discussed. This paper also presents the integration of D2D communication with other prominent technologies and demonstrates the importance of integration with possible solutions in improving network performance. We further investigate the challenges of D2D communication, opportunities, and future research directions of D2D in 5GB networks. In addition, D2D communication in 6G network challenges and open research areas are introduced.

INDEX TERMS 5G, 5GB, 6G, D2D communication, millimeter wave (mm-Wave), visible light communication (VLC), ultra-dense network (UDN), and unmanned aerial vehicle (UAV).

I. INTRODUCTION

Mobile wireless communication demands for higher data rates, lower energy consumption, low latency, coverage area, as well as efficient spectrum sharing are rapidly increasing day by day. The number of connected devices is estimated to be over 50 billion in the year 2020 [1]–[3], in which mobile data traffic is projected to grow monthly from 13.8 in 2017 to 110 Exabytes (EB) till the end of 2023 at a compound annual growth rate (CAGR) of 42% based on the Ericsson report [4]. All these issues should be resolved to provide and support the demands of the upcoming fifth-generation (5G)

The associate editor coordinating the review of this manuscript and approving it for publication was Stefano Scanzio¹.

and beyond (5GB). 5G was expected to launch in 2020 with a very high data rate and quality of services (QoS), and it aims to offer a 1000-fold rise in the total throughput. Moreover, in order to achieve a ten-fold increase in individual link throughput over the previous fourth-generation (4G) wireless networks [5], [6], various technologies are suggested to be considered in order to fulfill 5GB requirements such as an ultra-dense network (UDN) with machine-to-machine (M2M) in heterogeneous networks, in addition to millimeter-wave (mm-wave), massive MIMO, virtualization of wireless resources, visible light communication (VLC), energy harvesting, and cloud-based radio access network (C-RAN) [7]. A novel physical technology such as VLC has been suggested to deliver high data rates, where a

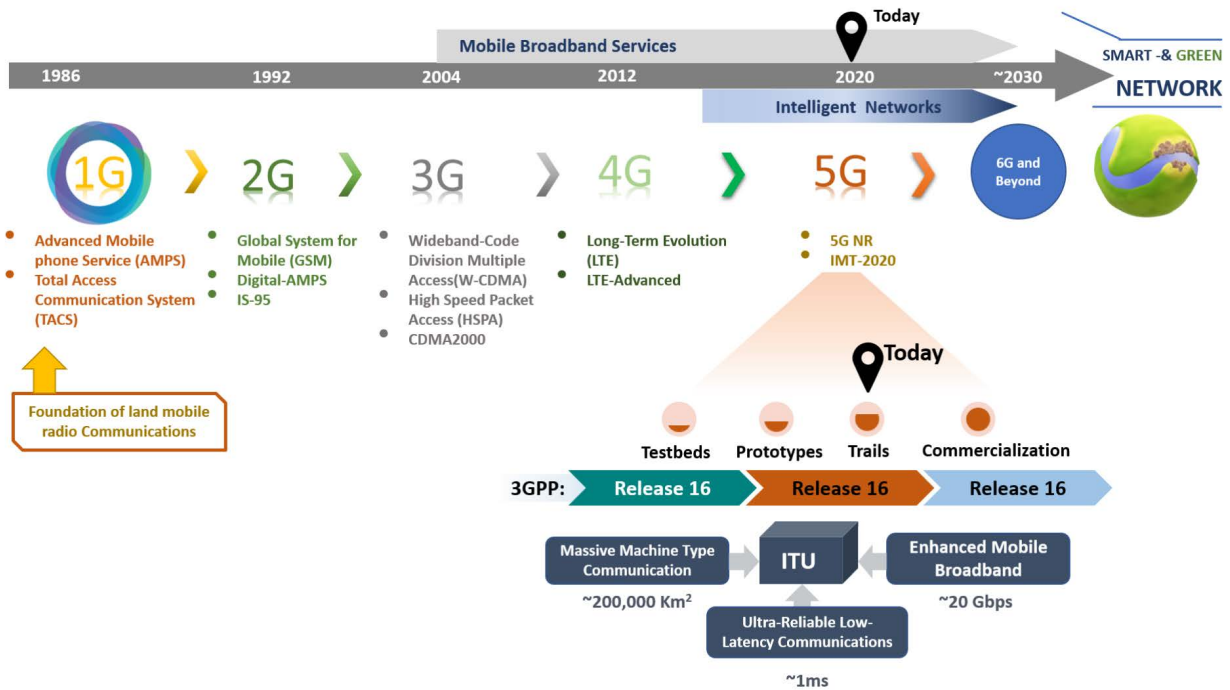

FIGURE 1. Developments of mobile radio communication networks generations [5].

considerable bandwidth of VLC technology could support higher data rates with up to 100Gbps and beyond [8]–[10]. Fig.1 illustrates the development of mobile communication networks, which involves 1G to 5G generations, technologies, systems, and standardizations.

Many techniques and approaches have been implemented to cope with the increasing demand for network capacity. New modulation techniques, signal processing, and spectrum allocation techniques were employed to improve spectral efficiency and link capacity. However, they require many small base stations in indoor environments in order to meet the requirements of the upcoming 5GB applications, although improving the channel capacity, transmission rate, bit error rate (BER) performance as well as signal-to-noise (SNR), could increase total spectral efficiency and bandwidth density [11], [12].

According to the current and expected requirements of communication networks, an emerging technology called device-to-device (D2D) communication has attracted attention as a critical key for cellular network performance enhancement in 5GB [13], [14]. D2D communication offers many advantages for cellular networks, namely; (i) higher transmission rate, (ii) enhancing energy efficiency, (iii) offloading the overloaded cellular traffic, (iv) wide cellular coverage, (v) reducing delay or latency, and (vi) higher spectral efficiency [15]–[18]. D2D communication can be used in several fields, such as public safety, network traffic offloading, military applications, social services, and gaming [19].

The standardization of D2D communication was reviewed by the third-generation partnership project (3GPP). 3GPP is the leading standardization organization for 5G systems,

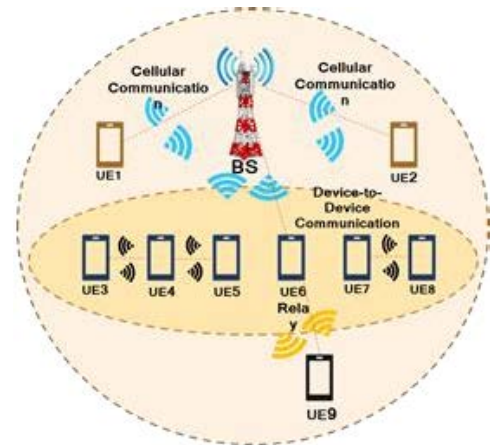

FIGURE 2. D2D communication and cellular network.

which defined a collection of D2D scenarios in 5GB networks [20], [21]. The latest 3GPP releases have given significant consideration to standardize D2D communication and combine it in the long-term evolution (LTE) advanced ecosystem [22]. Detailed critical analysis, features, and discussion on D2D communication standardization over 3GPP releases have been presented in [23]–[26].

Various survey works have made a greater contribution to the research on D2D cellular networks in terms of mode selection, resource allocation, interference management, security, etc., which have always been to improve the D2D system performance. However, a comprehensive survey of the current existing works on the aforementioned surveys in 5G, B5G,

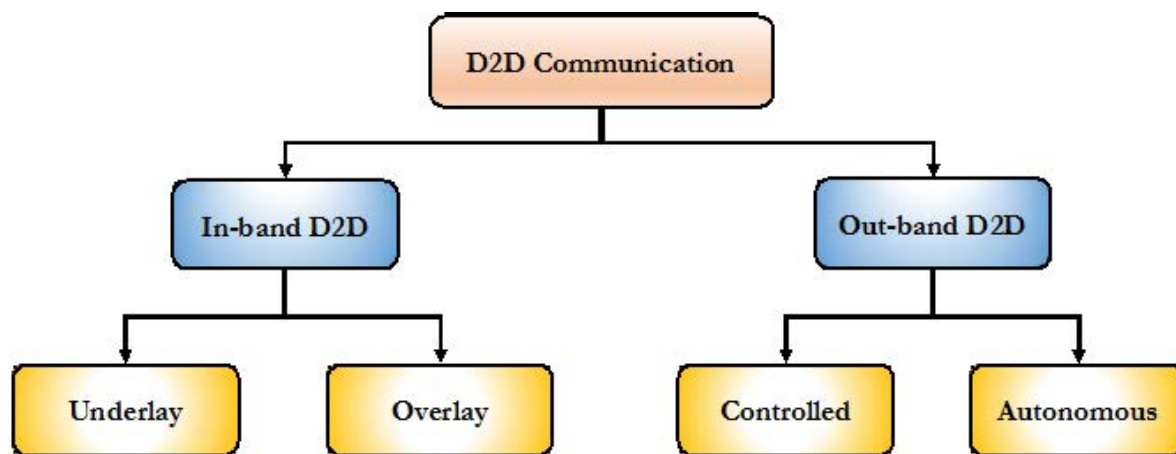

FIGURE 3. Basic classifications of D2D communications.

and 6G networks is missing in the literature. TABLE 1 shows a summary of comparison for the existing surveys with this paper.

The main contributions in this paper include:

- An investigation of D2D communication concepts in 5G networks, in which its classifications and various applications were discussed.
- A review of the capability of D2D communication and other recent technologies integration is provided, for the first time, to the best of our knowledge. These technologies include C-RAN, mm-Wave, IoT, VLC, UDNs, and UAVs. In addition, a discussion of the benefits of their integration to support 5G networks are provided.
- Various D2D communication challenges and possible solutions review are provided, with future research trends suggestions.
- To the best of the author's knowledge, this is the first review of D2D communications in the context of 6G which presents critical requirements for its success and outlines expected research directions for 6G.

The rest of this paper is organized as follows: Section II shows the concept and classification of D2D communication. Section III presents the application of D2D communication technology. Then, integrations between D2D and other technologies in 5G networks are discussed in Section IV. Section V illustrates the challenges and possible solutions for further development in the future. After that, Section VI describes the D2D in 6G and critical requirements for a successful 6G network. The lessons learned and key findings with suggestions for future research are demonstrated in Section VII and Section VIII, respectively. Lastly, conclusions are presented in Section IX.

II. D2D COMMUNICATION CONCEPT AND CLASSIFICATION

In the past decades, the transmission of information between devices could be performed by utilizing an electrical connec-

tion to transfer information through physical cables and connectors. However, due to some challenges raised by multiple connectors, radio frequency (RF) technology was employed to overcome these challenges. Thus, information was transmitted without human intervention, where RF signals traveled from and to the mobile user in the transmitter's side to the base station (BS), and then BS relayed these signals to the other mobile user at the receiver's side, which is standard in any typical cellular network as illustrated in [41]–[43]. After that, due to spectrum limitations of RF technologies in the cellular network, D2D communications have been proposed to handle Internet and mobile calls data traffic without any additional load to the core network [3], [44], which means direct communication between devices would be established without relaying the signal through the BS or core of cellular network as demonstrated in Fig.2.

A direct connection between two devices (i.e., mobile, tablet, PC, etc.) underlying cellular network represents a simple concept of the D2D communication mechanism, in which it could be classified based on spectrum utilization into in-band and out-band communication, as briefly demonstrated with different classification modes in Fig.3 [19], [45].

A. IN-BAND D2D COMMUNICATION

The motivation for selecting the in-band D2D (IBD) communication was its high ability to control a licensed spectrum; however, it suffers from interference between D2D users and cellular networks [45], [46]. Furthermore, it is also considered as one of the 5G technologies with spectrum efficiency that could be improved through reusing the frequency and time resources by the D2D users, in which resource sharing or allocation between D2D users could be performed in two ways, namely; underlay and overlay modes [43].

1) UNDERLAY MODE

In underlay mode, the D2D and cellular communications share the same wireless resources, as illustrated in Fig.4,

TABLE 1. Comparison with existing D2D communication surveys.

Ref	Challenges							
	Interference Management	Security	Mode Selection	Generation	Resource Allocation	Mobility	Devices in Heterogeneous Network	Integration with recent technologies
[27]	✓	✓	X	-	X	X	X	X
[28]	X	✓	X	-	X	X	✓	X
[29]	X	X	X	-	✓	X	X	✓
[30]	✓	X	X	-	✓	X	✓	X
[31]	✓	✓	X	5G	X	X	X	X
[32]	✓	✓	✓	-	✓	✓	X	X
[33]	X	✓	X	5G	X	✓	X	X
[34]	X	X	✓	-	✓	X	X	X
[35]	X	X	X	-	X	✓	✓	X
[36]	✓	X	✓	LTE-A	✓	X	X	X
[37]	✓	✓	X	5G	✓	✓	✓	X
[26]	✓	✓	✓	5G	X	X	X	X
[38]	✓	X	✓	5G	X	X	X	✓
[39]	X	X	X	5G & B5G	✓	✓	X	X
[40]	✓	X	X	-	X	✓	✓	X
This paper	✓	✓	✓	5G, B5G & 6G	✓	✓	✓	✓

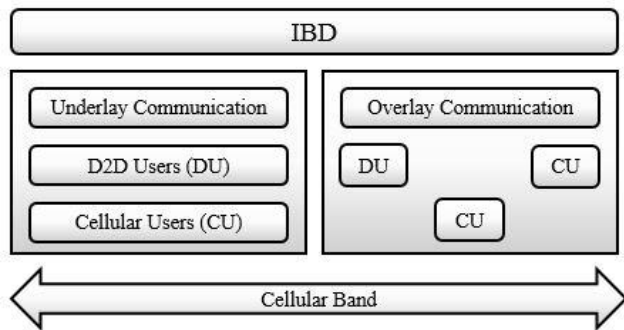

FIGURE 4. Cellular band distribution for cellular users and D2D users in IBD [48].

where it could improve cellular coverage, spectrum efficiency, and energy efficiency. This is accomplished by utilizing several techniques through the network that comprises of resource allocation, interference mitigation, and diversity techniques [43]. Therefore, direct D2D communication underlay mode could offer high spectral efficiency as well as low latency for an end-to-end connection and physical link proximity, thus making it a possible solution for achieving the requirements of 5G.

2) OVERLAY MODE

In overlay mode, D2D and cellular communications are given a dedicated portion of the wireless resources so that cellular links are not influenced by D2D links [47]. Nevertheless, interferences between D2D links remain present. The cellular band or spectrum portion of overlay is shown in Fig.4.

B. OUT-BAND D2D COMMUNICATION

The out-band D2D (OBD) communication is another exciting and attractive area for many researchers today since it uses an

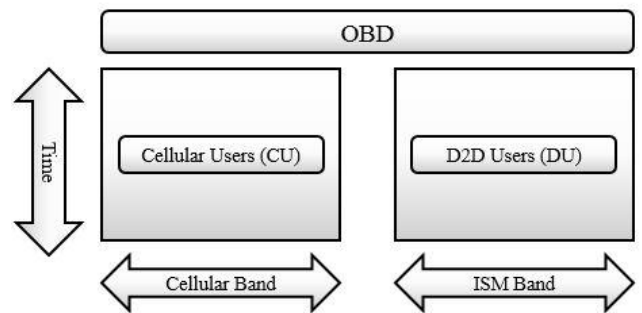

FIGURE 5. Cellular band and ISM band distribution for OBD [48].

unlicensed spectrum utilized in various industrial, scientific, and medical (ISM) applications. Besides, it is considered a 2.4G technology, making it difficult for interference to occur between cellular and D2D communications, as seen in Fig.5. However, the OBD suffers from an uncontrolled way of unlicensed spectrum [43], [49]. To employ the unlicensed spectrum band, an additional interface that performs Wi-Fi direct, Bluetooth, or Zig-Bee is a must. OBD communications are classified into two modes, based on other interface occurrences, namely controlled and autonomous modes, which are briefly illustrated as follows:

1) CONTROLLED MODE

In this mode of OBD communication, the cellular network or base station will be controlled by radio interfaces. In previous studies, cellular networks have employed advanced management techniques that can improve the reliability and efficiency of D2D communications [19], [43], and improve

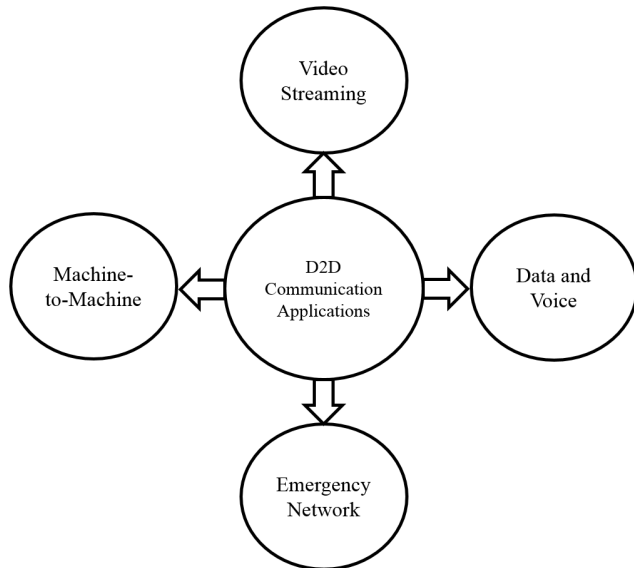

FIGURE 6. D2D-5G environment scenarios and applications.

the system performance in terms of power efficiency and throughput. TABLE 2 shows IBD and OBD comparisons.

2) AUTONOMOUS MODE

Alternatively, this mode does not require any changes at cellular networks or base stations. It could be easily deployed, which means that autonomous D2D interfaces could be coordinated by users, resulting in cellular network overhead mitigation [19]. These autonomous D2D interfaces could be Bluetooth or Wi-Fi direct.

III. D2D COMMUNICATION APPLICATIONS

D2D communication can be employed in several short range applications, including video streaming, (M2M), data and voice, and emergency network, as illustrated in Fig.6. Furthermore, D2D can be used in online gaming, multicasting, local advertising, cognitive-communication, cooperative communication, and the Internet of things (IoT) [35], [50]–[52].

A. DATA SERVICE AND LOCAL VOICE

The transfer of data service between two devices within D2D coverage areas can be achieved via D2D communication. An increase in data rate and latency reduction could be acquired through D2D technology deployment [50], [53]. Additionally, voice chat services could be supported within narrow proximity coverage areas such as cubicles, big halls, or can deliver to nearby devices. Therefore, local voice transmission through D2D technology could improve network performance in terms of data rate, QoS, and latency in a manner that could overcome real-time voice transmission limitations [54]–[56].

B. VIDEO STREAMING

According to Cisco, video sharing through the Internet is projected to take up over 90% of internet traffic in the near

future [57]. Video streaming involves transferring data or contents in a compressed form via the Internet in real-time, which results in watchable content without the need to wait for a completely downloaded video file [50]. However, Point-to-point (P2P) technology has the potential to allow all users to share their videos through direct communication, cellular network, and offloading, as illustrated in Fig.7 (step 4) [58]. It offers an alternative improved method of video streaming.

Alternatively, D2D technology is better than conventional cellular networks in sharing video streaming, video conferences, and video chat between devices within the same cellular or adjacent networks nearby. According to future network requirements for video streaming, the quality of experience (QoE) is strongly influenced by video quality adaptation. Therefore, a new quality adaptation technique was proposed for scalable video in D2D communication network [13]. In addition to an extensive survey, a discussion on video transmission and QoE was conducted in studies [59], [60], which handled challenges and proposed possible solutions to enhance the video quality and manage interferences between cellular links and D2D links.

C. MACHINE TO MACHINE

M2M communication is considered one of the promising technologies for M2M telemetry, which involves devices and objects with communication and computing capabilities without the need for human connection [50], [61], [62]. M2M is often utilized to monitor certain automatic transmissions of data collected from remote sensors to a central unit to be analyzed. This is achieved by software agents or human beings, as shown in Fig.8. M2M technology has many applications, including, but not limited to, car automation, smart houses, environment monitoring, industrial automation, military operations, etc. Furthermore, M2M machines are often positioned near each other in many applications to deploy D2D connections within a building [63], [59]. Implementing a direct D2D route in M2M technology will result in load distribution and delay reduction in deployed networks. Moreover, a cognitive M2M could be employed to maximize energy efficiency [64] by utilizing a recently developed joint optimization algorithm that features power control, peer discovery, channel selection, and time allocation problem.

D. EMERGENCY NETWORKS

The urbanization in both developing and developed worlds are increasing rapidly. Currently, more than 50% of the population is concentrated and lives in cities. Globally, this percentage is expected to grow rapidly in the upcoming decades. Therefore, flexible and reliable communication networks in dense urban areas must secure global cities from unfortunate terror attacks, such as the New York City 9/11 catastrophe and 7/7 metro bombings in London [65]. Furthermore, in the event of natural disasters and during search and rescue operations, base stations are often shut down or overloaded, and could only provide limited services for a specific limited number of users or equipment. Hence, in emergencies, D2D-

TABLE 2. Comparison between in-band and out-band D2D communication.

In-Band D2D Communication	Out-Band D2D Communication
Exploits spatial diversity, resulting in enhanced spectral efficiency	Does not result in an improved spectral efficiency
Base stations control results in better QoS management	No control needed at the base station. Thus, better QoS management is not supported
High interference levels between D2D communication, cellular communication, and among D2D users	Interference problem avoided by different bands of operation between cellular and D2D communication
No extra interface is needed (e.g. Wi-Fi) by the device	Devices require an additional interface. Thus, two interfaces are needed for a successful device operation.
High possibility of resource wastage	More accessible resource allocation without wastage
No coding/decoding involved; only a single interface is used	Coding and decoding of packets are essential as different interfaces use different protocols

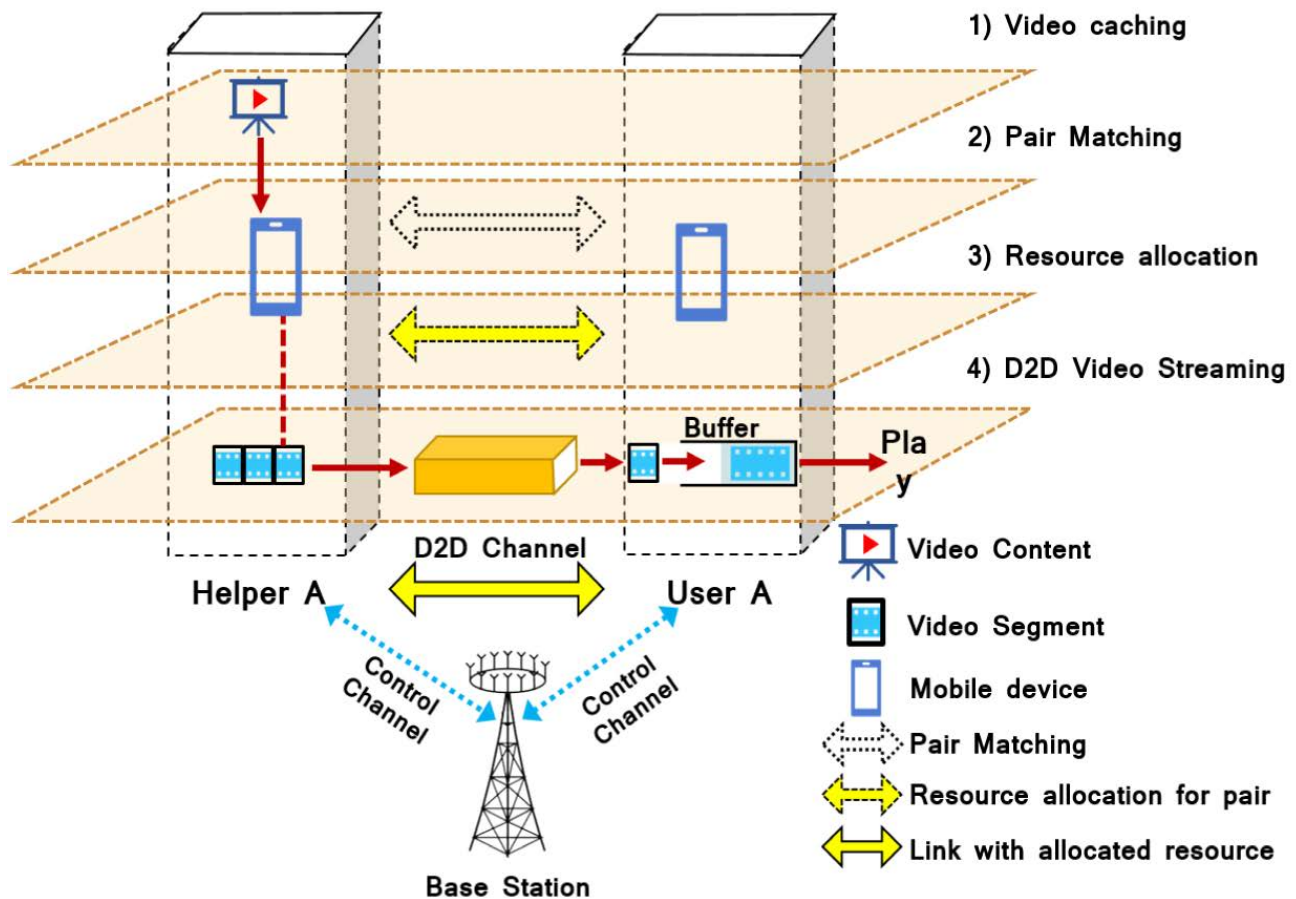

FIGURE 7. D2D video sharing [58].

based-technology networks could provide temporary broadband services for emergency workers, doctors, and nurses to access patients’ data, in addition to reporters and journalists to cover news and quickly disseminate government emergency announcements in a timely and orderly fashion [50], [66]. Moreover, unmanned aerial vehicles (UAV) were proposed as an emerging approach to deploy emergency networks in the case of damaged network infrastructure [67]. Fig.9 shows a large number of D2D devices that communicate with

each other in a small network, in which this small network can relay the data to other remote devices through a UAV deployed emergency network.

Although public safety, traffic officers, national security, and disaster management are heavily flooded by D2D communications, it could be further extended to cover a wide range of applications such as smart parking in smart city scenarios, smart grids, social networking, and smart homes, etc. Alternatively, D2D and IoT technologies combination

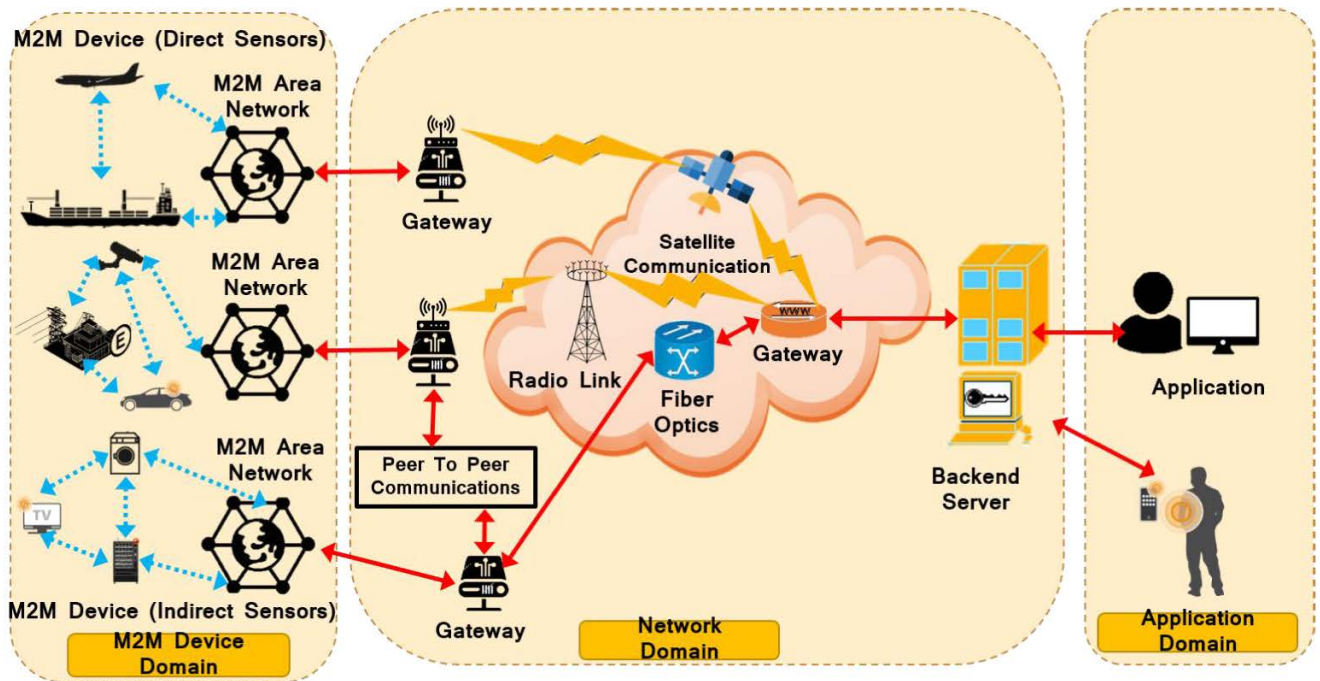

FIGURE 8. M2M system model.

or hybridization is an emerging approach that could potentially be utilized in intelligent Internet of Vehicle Things (IoVT), Internet of Medical Things (IoMT), e-medicine, quick disaster relief action, cloud computing, and proximity services [11]. Fig.10 presents a general overview of the D2D communications system with IoVT, IoMT, traffic, and public safety.

IV. INTEGRATION OF D2D COMMUNICATION WITH RECENT TECHNIQUES

Rapid advancements, growth, and innovations in mobile communications technologies result in a higher number of heterogeneous cellular networks. Recent advancement in cellular networks is the introduction of very-high-speed 5G technology to the mobile market. Therefore, newly-introduced 5G networks and beyond would comprise all types of advanced technologies that offer remarkable services. D2D underlay cellular network is an advanced technology that could offer improved energy efficiency, increased capacity, and many other advantages due to its cellular network traffic offloading capabilities. However, it faces many challenges at the same time [68], [69]. To overcome all these challenges as well as enhance the network performance, we investigated the integration and combination of D2D communication with other advanced technologies such as the IoT, VLC, UDN, etc. Fig.11 illustrates the most prominent technologies that can be integrated with D2D communications to support 5G networks. A brief introduction of these technologies is presented in the following section.

A. CLOUD RADIO ACCESS NETWORK

Cloud radio access network (C-RAN) is a promising access network technique that could be employed to address increased mobile traffic and optimize network performance [70], [71], in addition to scalability and heterogeneity management of upcoming wireless networks. C-RAN has a centralized object that aids in advanced joint mobility and radio resource management, which can reduce the interference and increase data rate as well [72]. The uplink and downlink scenarios for C-RAN were investigated [73], [74], where different frameworks and strategies were implemented to improve its capacity and optimal outage probability was obtained. Although C-RAN has many advantages, it also suffers from a few drawbacks, such as link delay, one of its major inherent issues. To avoid this issue, a new D2D-Communication-based combination paradigm was proposed in [75].

D2D and C-RAN technologies combination does not only play a significant role in solving the delay issue, but it could also fulfill most of 5G requirements in terms of cost, delay, capacity, mobility, and energy efficiency [75]. Both D2D and C-RAN have been investigated to optimize resource allocation and mode selection simultaneously in [76], [77], which resulted in higher throughput. D2D can be enabled in C-RAN to improve QoS as well as minimize transmitted power in [78]. Also, C-RAN-based-D2D could be employed to manage resource allocation for 5G heterogeneous networks [79], [80]. The performance evolution of D2D-C-RAN based network in 5G heterogeneous UDN has yet to be

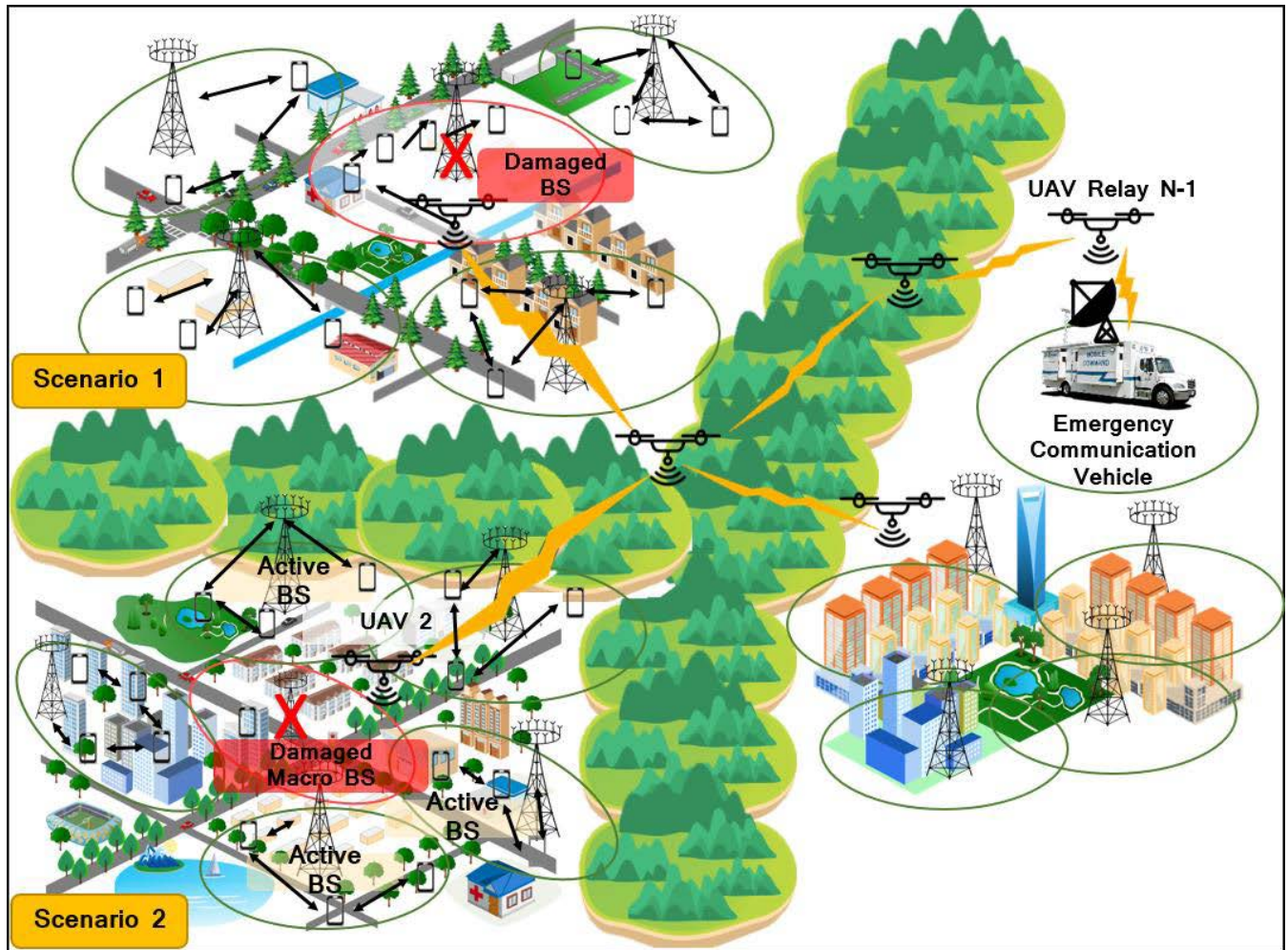

FIGURE 9. Structure of emergency networks in disaster using D2D and UAV technologies.

investigated. More studies are required to ascertain its fulfillment of the 5G requirements. Moreover, new algorithms for delay reduction in hybrid D2D-C-RAN network is needed to improve the performance in terms of interference, optimal outage probability, throughput, QoS, etc.

B. MILLIMETER-WAVE

The electromagnetic spectrum is becoming more and more congested; as a result, its resources have become sparse due to the massive applications demand, which occupies most of its remaining frequency bands. Therefore, moving to millimeter-wave (mm-Wave) bands has become a necessity for the large unused bandwidths [81], [82]. The mm-wave spectrum is described by an extremely high-frequency band (EHF) and ranges from 30 to 300 GHz. These bands could support 5G networks with a possibility of obtaining 1000 folds the capacity compared to 4G solutions [76], [81]. Employing D2D communication in micro-wave bands suffers from high interference and insufficient bandwidth [83]. Therefore, enabling D2D in an mm-wave band is another possible solution to those problems.

Mm-wave provides low latency and high data rate; however, it suffers from inefficient power consumption and propagation shortcomings [84]. To overcome these challenges, power consumption could be improved by D2D communication integration with mm-wave technology as introduced in [85], which resulted in improved energy efficiency. This integration provided high data rates, low interference as well as improved power consumption [86]. In addition, the outage probability and data rates were investigated for a combination of both and based on various mm-wave parameters [86]. A new optimization problem formula has also been implemented to investigate resource and power allocation of D2D and mm-wave integration in [87]. Besides, An extensive survey about integrating both technologies has been done, which covered cooperative communication, caching, scheduling techniques, beamforming, and their possible solution approaches [88], [89].

Moreover, both technologies suffer challenges such as blockage modeling, heterogeneous networks, and densification. Despite all mentioned challenges, there are great chances for integrated D2D communication with mm-wave to become a promising solution form many issues relating to

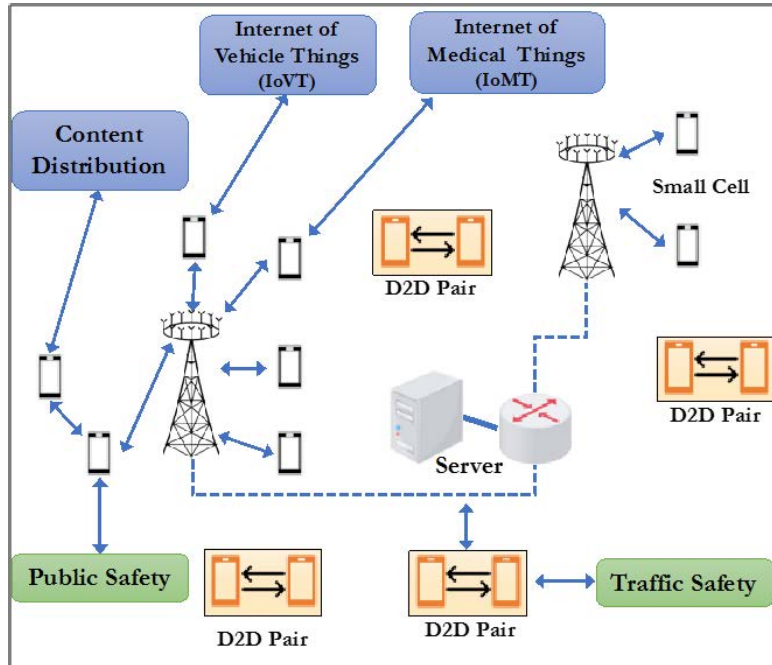

FIGURE 10. General applications for D2D communication system [51].

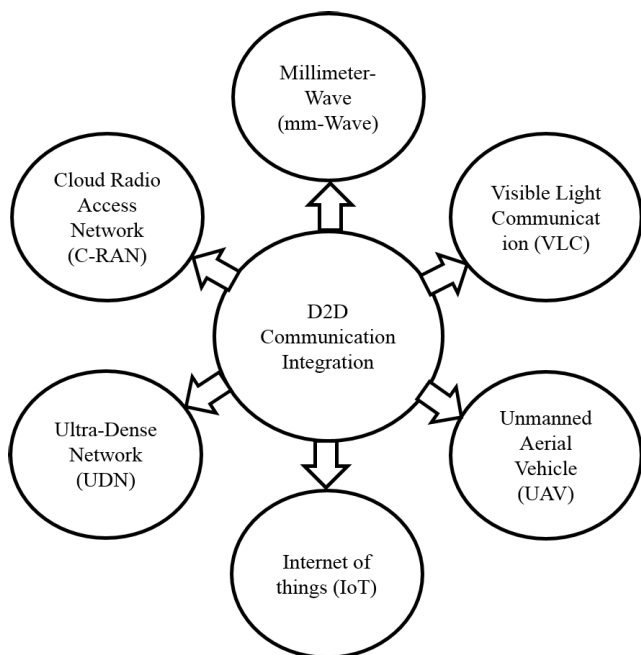

FIGURE 11. Integration of D2D communication with different recent technologies in 5G.

5G and beyond. The integration of both technologies opens areas for researchers in the academia and industry to realize and investigate D2D communication integration in the mm-wave spectrum band.

C. INTERNET OF THINGS

Internet of things (IoT) is an emerging technology used to create an integrated ecosystem for various devices to communicate with each other via the Internet [2]. Therefore,

similar to the method that humans utilize in the Internet, devices are the major users in the IoT ecosystem [90]. The fast growth of smartphones plays a significant role in supporting IoT technology and it has gained a strong interest by many due to its features that can support the creation and the development of various services and applications. Moreover, D2D and IoT technologies integration have the potential to satisfy upcoming 5G requirements, especially in terms of system capacity, latency, or delay, as well as spectral efficiency [51], [91]. Two interference management techniques termed as cooperative pairing (CooP) and fixed power margin (FPM) have been investigated to improve the outage probability and QoS requirement for the combined D2D and IoT ecosystem [92]. The role of D2D communication in the development of the IoT ecosystem was extensively discussed, where the past, current status, and expected future issues were also presented [93]. Fig.12 shows the integrated D2D communication with 5G IoT networks [94].

D. VISIBLE LIGHT COMMUNICATION

RF technology suffers from capacity crunch, interference, and other constraints, that affect the performance of the communication system. In order to avoid some of these constraints, a new technology named VLC was introduced [95]–[97]. VLC features a high bandwidth that could reach up to Terahertz (THz), in addition to low power, license-free deployment, and interference immunity [98], [99]. TABLE 3 provides a comparison between VLC and RF technologies [100], [101]. Similar to D2D communications, VLC system has limited coverage distance. Therefore, both technologies would be suitable for indoor applications; such scenarios can produce high capacity and high data rates.

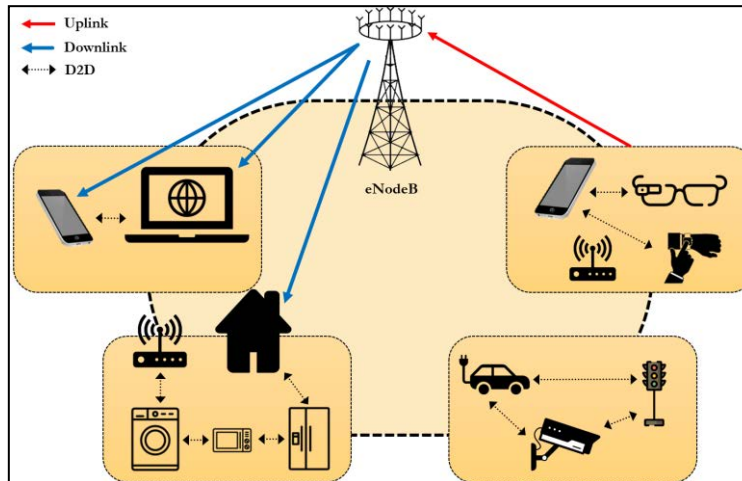

FIGURE 12. Integrated D2D communications with 5G IoT networks.

TABLE 3. RF versus VLC technologies [100], [101].

Parameter (s)	VLC	RF
Spectrum band	~ 400 THz to ~ 780THz	~ 3GHz to ~ 300 GHz
Spectrum allocation	Unlicensed	Licensed
Applications	Communication & illumination	Communication
Power consumption	Low	Medium
Infrastructure	Illumination	Hotspot point
Complication	Low	High
Multipath fading	No	Yes
Coverage Area	Bounded	Wide
Safety	Unregulated	Intensity regulated
Electromagnetic Interference	No	Yes
Security	High	Bounded
Information delivery	Carried on optical intensity	Carried on electric field
Signal	Real valued	Complex-valued

The hierarchical game method was utilized to investigate resource allocation for a hybrid D2D and VLC in heterogeneous networks [96]. It was shown that hybrid RF-VLC in D2D communication network achieved improved performance in terms of capacity crunch in indoor environments [102]. Furthermore, an RF-VLC D2D system maximized the capacity of RF D2D communication and VLC D2D communication systems with rates of 4.1 and 1.5, respectively [103]. Fig.13 illustrates a hybrid VLC-RF link in a D2D communication system, where device user equipment (DUE) represents the device user equipment, T and R denote the transmitter and receiver, respectively.

The mobility management of combined D2D communication with hybrid RF/VLC bands has been investigated in [104], [105]. The combination of all these technologies could improve system capacity and overcome the overcrowded RF bands [10]. Therefore, new algorithms were developed for D2D communication to switch from RF to VLC and vice versa based on average energy efficiency, sum capacity, and outage ratio.

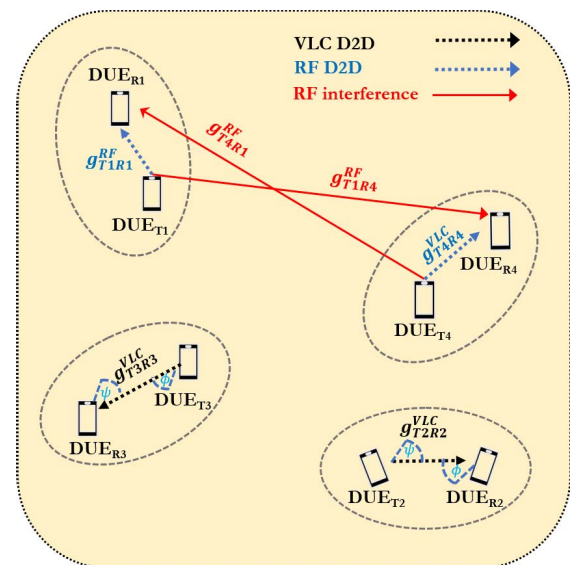

FIGURE 13. Hybrid VLC- RF in D2D communication system.

E. ULTRA-DENSE NETWORK

Currently, researchers are discussing and investigating the potential of combining ultra-dense networks (UDNs) with

various technologies in order to fulfill the extraordinary capacity requirement of 5G [106], [107]. The distribution of ultra-dense small cells instead of conventional macrocells

in the coverage area is known as UDN. However, UDN introduces new challenges that need to be solved, such as interference, degraded QoS, and high energy consumption. To overcome these challenges, UDN should be integrated with other technologies such as D2D communication. Fig. 14 shows a simple combination of UDN and D2D communication, in which different cell sizes such as macrocell, femto-cell, and picocell are distributed to enhance the rising number of devices or user equipment (UE) [108]. Moreover, the UE or devices located at cell edge that lacks connectivity, due to coverage limitations, require a relay for incorporation and connection with the D2D communication cell.

Although UDN has interference challenges, QoS, and other constraints, it could improve the performance of the network and increase its capacity 100-fold [109]. Furthermore, D2D communication integration is a significant factor in saving energy consumption due to the massive cell distribution within UDN [108]. Besides, it can provide support for other solutions that could overcome the challenges to satisfy the requirements of 5G and beyond.

F. UNMANNED AERIAL VEHICLE

In remote, disaster-affected, and rural areas, it is often difficult to build wireless networks due to challenging terrain or lack of infrastructure. However, unmanned aerial vehicles (UAVs) could be immediately deployed to establish a D2D authorized wireless network with high QoS, which make them a promising technology for emergency scenarios [110]–[112]. Alternatively, D2D communication plays a significant role in improving the performance of UAV in terms of capacity and coverage expansion with proper communication in wireless cellular networks [113].

Potential challenges of integrating UAVs and D2D communication networks were investigated in [54], in which the employment of dynamic multi UAVs was explored. Moreover, a 3D resource sharing between D2D and UAVs was investigated to improve the spectral efficiency of cellular networks in [114]. Besides, in [115], the authors proposed and evaluated the performance of a couple of mode selection schemes for D2D-enabled UAV-based wireless networks, where they utilized received signal strength threshold and average distance threshold to improve signal quality and connectivity in the case of emergencies. Furthermore, D2D communication and caching technologies were employed to mitigate UAV-assisted cellular network traffic [116]. Besides that, trajectory optimization and analysis of cache-enabled UAV-assisted cellular networks based on D2D communication underlay were discussed, in which the dynamic and static UAV deployments were considered. Although both UAV and D2D technologies have various advantages and could be promising candidates for 5GB network fulfillment, their high mobility and dynamic topology, when combined, could hinder the performance of allocation algorithm in a conventional channel, in addition to interference, energy consumption, and a limited number of available orthogonal channels for resource allocation. The development of new algorithms and

optimization solutions for these issues have yet to be resolved and remain an attractive problem to be researched in the future, along with the potential use of UAV as a portable energy source, due to its flexibility.

V. CHALLENGES AND POSSIBLE SOLUTIONS FOR D2D COMMUNICATION IN 5GB NETWORKS

As discussed previously, D2D communication presents a novel paradigm and standard that could be incorporated in contemporary mobile cellular networks, in which it can facilitate improved data exchange between proximate devices. Network performance improvements are continuously needed. Therefore, mobile operators are consistently developing technologies that support close-proximity services by advancing D2D communications technologies [28].

The taxonomy challenges for the D2D communication technique in 5GB are as demonstrated in Fig. 15. It includes the different parameters which categorize the available literature in D2D communication networks. The taxonomy includes six divisions, each of which displays various parameters, their sub-divisions, and the related literature. The parameters on which the category is done are resource allocation of the radio spectrum, interference management, compatibility between devices in heterogeneous networks, mode selection, security, and mobility.

Resource allocation for D2D communication in 5GB is either underlay or overlay, and both are categorized as centralized, distributed, and semi-distributed. It is also managed by various algorithms and optimization problems [117]–[119]. Interference is classified into interference cancellation, interference coordination, and interference avoidance [26], [120]. Furthermore, interference cancellation is divided into three types known as SIC, PIC, and IIC. Various mechanisms are employed for interference avoidance, which includes mode selection, joint power control, transmit power control, joint resource allocation, and MIMO techniques.

Heterogeneous network is categorized into access mode, cell type, and network model based on the past works [121]–[123], and each category involves sub-branches. Mode selection in D2D communication is classified based on transmission modes and control. Both of them are divided into sub-division as discussed in [124], [125].

Security is categorized into requirements, threats, and solutions. The requirements are discussed, which contain C\I, Au, FAC, Pr, Re, A\D, and NR [126], [127]. Besides that, vulnerability classifications include physical attacks, negotiated IDs, configuration attacks, protocol attacks, attacks on core networks, and user data and privacy attacks [28], [126], [128]. Four types of security solutions are classified, namely secure routing, access control, physical layer security, and authentication, and key management [126]. The mobility management contains joint handover, half handover, and sidelink-assisted handover [27], [104], [129]. All these challenges and possible solutions for D2D communications in the context of 5G networks and beyond are discussed in the following subsections. Also, some notable methods with the ability

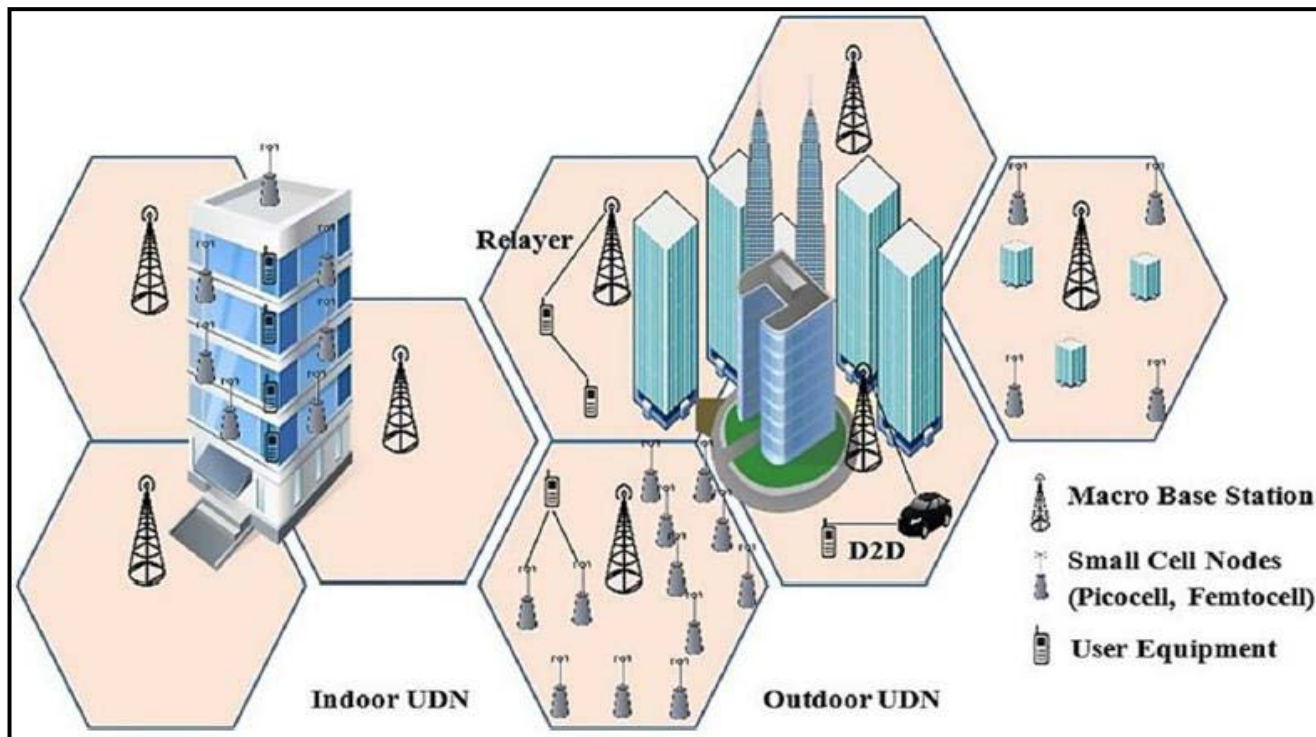

FIGURE 14. General example of UDN [108].

to solve D2D communication challenges were investigated, along with in-depth technical discussion that includes objectives, contributions, mechanisms, and results (see Table 4).

A. RESOURCE ALLOCATION

Radio resource allocation is an essential element in maintaining and creating direct connections between D2D pairs under cellular networks [32], [130]. The advantages of D2D radio resource allocations are flexibility, ubiquitous availability, low latency, and low cost [51]. Spectrum sharing between D2D users and cellular user equipment (CUE), mainly within in-band mode, can improve spectral and energy efficiency by managing co-channel interference [30], [131], [132]. Another novel technique is sparse code multiple access (SCMA), which was utilized in D2D communications for 5G networks paradigm to improve resource and power utilization in hybrid cellular networks [133]. However, security issues and fairness of communication have yet to be explored. Meanwhile, various resource allocation methods with different performance objectives were investigated in [51], [134]–[136]. For future directions, effective resource allocation techniques are needed to satisfy the requirements of 5G and beyond to achieve minimized signaling overload in the cellular network (base station), obtain acceptable user data rates, maximize network throughput, and meet QoS demands.

B. INTERFERENCE MANAGEMENT

Interference from cellular users (CUs) is one of the primary impairments influencing D2D communication. Reuse of cellular network resources and, therefore, the coexistence of

CUs and D2D pairs will lead to elevated interference problems. D2D user experience often suffers from two types of interference; intracell and intercell interference. Both depend on operation modes of the D2D network and could occur in uplink or downlink scenarios [31]. They can obstruct successful transmissions through signal to noise ratio (SNR) reduction at the receiver end and result in decreased QoS as well. Transmitted power as a reduction technique is usually implemented to mitigate the effect of UEs interferences. However, it results in a QoS tradeoff at the receiver end.

Various interference management techniques have been discussed and proposed in previous studies, including interference coordination, interference avoidance, and interference cancellation. Moreover, transmissions scheduling, hybrid automatic repeat request (HARR), coding, and modulation techniques are also implemented to improve the robustness of the signal against noise and mitigate unwanted interference [32]. Research in the approaches mentioned above remains active.

The future direction of interference management of D2D in 5G networks concentrates on the power control and interference mitigation techniques, and both can lead to improved energy utilization, which is one of the essential aims of the future generation of wireless networks.

C. COMPATIBILITY BETWEEN DEVICES IN HETEROGENEOUS NETWORK

5G communication focuses on IoT and D2D technologies for various applications such as connected smart cars, active monitoring, smart houses, connected e-health,

TABLE 4. Technical analysis and solutions for D2D communication challenges.

Ref.	Objectives	Contributions	Algorithms	Methodology	Results
[137]	Maximise the sum of all D2D pairs proportional fairness functions	A new joint RA and power control scheme to improve both user fairness and network throughput of the underlay D2D communication	Joint RA and PC	Designed an underlay D2D communication model; multiple DUs with CUs co-exist within the exact cell and clarified the proportional fair scheduling	-Enhance the network throughput -Acceptable QoS for all D2D pairs
[138]	Maximise energy efficiency and power transmission of D2D pairs. To manage RA and guarantee QoS for all D2D pairs.	Joint power allocation and sub-channel algorithm for D2D pairs based on NOMA	Sub-channel allocation. Power allocation.	The algorithm employs the Kuhn-Munkres technique to assign a channel for D2D pair and develops an optimal power allocation issue using Karush-Kuhn-Tucker conditions	Improve throughput and energy efficiency
[139]	Identify optimisation problem to maximise communication links in the network. To propose D2D RA and PC framework.	A pure D2D model that offers flexibility for RA	-Colour-based Grouping -Group Reforming -Power Control.	Several algorithms are employed to manage the RA for D2D communication.	-Improved network performance - Guaranteed fairness between links
[140]	Investigate RA for D2D using dynamic game theory	- A game-theoretic based utility function maximisation scheme - A utility function maximisation game to optimise the transmission rate of D2D communication.	Game theory	Model the RA issue between cellular and D2D links as the utility maximisation game	- Lower transmission time - Enhanced sum transmission rate
[141]	Investigate the RA problem for intercell scenarios	An RA protocol and algorithm based on Nash equilibrium (NE) derivations.	Game model	-Three intercell scenarios about the RA problem were investigated -A game model was developed to manage the RA problem for the scenarios	- Enhanced sum rate - Enhanced sum rate gain
[118]	Optimise RA	Integrate D2D with cognitive radio method to enhance RA	-	- New cognitive subcarrier allocation method - A power allocation technique	Improved transmission rate of D2D pairs
[56]	Improve the throughput of D2D pairs.	Maximise transmission rate over different cell loads and channel condition	-	A model for D2D communication in unlicensed and licensed interoperable networks	Enhanced D2D pairs throughput and network management
[132]	Investigate resource allocation and power control	- Optimise issue of power allocation and RB allocation for cellular and D2D links - Formalised RB allocation and power control of cellular and D2D links by maximising secrecy-capacity of the system	Tabu search (TS) meta-heuristic	A decomposition approach	- Improved security - Achieved optimal RB allocation
[142]	- Utilise RA of single channel by multiple D2D pairs - Increase sum capacity	New low complexity RA algorithms	Priority-Based Sequential	Reuse RA of single channel by multiple D2D pairs	- Improved sum D2D capacity - Low complexity (linear)

TABLE 4. (Continued.) Technical analysis and solutions for D2D communication challenges.

[143]	<ul style="list-style-type: none"> - Investigate RA for BS and analyse system equilibrium and efficiency - Determine Unknown Channel Quality issue and its effect on resource utilisation efficiency 	Some mechanisms with game theoretical method is proposed to assign channel resource effectively under realistic scenarios	Game Theory	<ul style="list-style-type: none"> - Modelled the greedy conducts of UE/BS and derived the equilibrium - A linear search algorithm with contract-based mechanism was used to address Unknown Channel Quality issue 	Improved system efficiency
[144]	<ul style="list-style-type: none"> - Investigate interference reduction techniques - Study multi-cell interference in IBD communication 	Viable solutions for interference management problems in IBD communications	-	Critical review study	<ul style="list-style-type: none"> - Flexible multi-cell D2D pair communication model -Reduce interference and network load
[120]	Review state-of-the-arts methods to reduce interference between DUs and CUs	<ul style="list-style-type: none"> - Classify various interference mitigation techniques based on their underlying methods -Qualitative comparison among several interference mitigation methods 	-	Critical review study including stochastic geometry, game theory, graph theory, evolution theory, queuing theory.	Present the open challenges with possible solutions for the interference management of D2D communication in 5G cellular networks
[145]	Investigate interference management in IBD D2D communication under CSI	Optimise the transmit power of D2D pairs. Maximise the BS throughput with acceptable SINR.	Low complexity heuristic	Formulate problem based on average CSI and the availability of instantaneous	Maximum obtainable cell capacity
[146]	Study interference and mobility management	<ul style="list-style-type: none"> - Proposes a PC algorithm to manage interference and power transmission - Propose a new method to reduce handover delay 	Greedy	<ul style="list-style-type: none"> - Select optimal route using PC techniques - Greedy algorithm is used to minimise interference 	<ul style="list-style-type: none"> - Reduce interference - Improved network capacity - Reduce delay in complex mobility problem
[147]	Reduce interference of D2D multicast communication	An RA technique is proposed based on a frequency reuse approach. Cell sectorisation technique is used to reduce interference between CUs and DUs.	-	<ul style="list-style-type: none"> - Formulate the sum throughput optimisation issue, where individually multicast D2D set can reuse just an uplink cellular connection at a time. - The fractional frequency reuse (FFR) method is used and supposed that CUs and DUs can share resources in a non-orthogonal technique - The proposed technique was evaluated using Monte-Carlo simulation 	<ul style="list-style-type: none"> - Higher throughput - Minimise power consumption
[148]	<ul style="list-style-type: none"> - Investigate interference reduction for IBD communication - Analyse the effect of downlink interference in 5G networks 	<ul style="list-style-type: none"> - Formulate a generic expression for SINR - New approaches are proposed for interference management 	-	Three approaches are used to manage several types of interference; closed mode D2D approach, novel hybrid frequency reuse with almost blank sub-frame approach, and combined approach	<ul style="list-style-type: none"> - Reduce interference - Higher SINR that is closer to SNR
[149]	Develop efficient PC schemes to reduce interference	Two PC schemes are proposed: PCS 1 and PCS 2, to reduce interference and offer better performance	PCS 1 and PCS 2	<ul style="list-style-type: none"> - PCS 1 and PCS 2 reduce the effect of interference - eNB is installed at the cell centre and the simulation is conducted for a single-cell scenario 	Improved data rates and high SINR

TABLE 4. (Continued.) Technical analysis and solutions for D2D communication challenges.

[150]	<ul style="list-style-type: none"> - Evaluate MS and PC for interference management - Investigate distributed and centralised MS and PC algorithms for D2D in 5G networks 	Both MS and PC algorithms are proposed for D2D utilising distributed and centralised methods	<ul style="list-style-type: none"> - MS - PC 	Derived expression and mathematical form for min and max amount of power	<ul style="list-style-type: none"> - High SINR threshold - Improved coverage probability
[151]	<ul style="list-style-type: none"> - Investigate interference management for D2D pairs in heterogeneous cellular network 	<ul style="list-style-type: none"> - Reduce computational sophistication and use limited spectrum resources efficiently - Guarantee the lowest communication QoS of all D2D users - The proposed interference limited area (ILA) enabled D2D users to use different communication modes to solve the issue of spectrum resources waste 	Joint MS and PC-ILA.	<ul style="list-style-type: none"> - Newly joint MS and PC scheme is proposed - PC is used to adjust the ILA dynamically for reducing severe interference - MS approach is employed to manage spectrum resources efficiently 	<ul style="list-style-type: none"> - High SINR - Improved sum data rate
[152]	Identify and analyse three key factors: SINR, cell density, and outage probability that affect the performance of D2D in heterogeneous cellular networks	<ul style="list-style-type: none"> - An acceptance Interference Region algorithm is proposed to guarantee the QoS for all D2D pairs - A mathematical model is designed that included SINR, small cell density, and network models for system performance analysis and modelling 	<ul style="list-style-type: none"> - Acceptance interference region - ON-OFF 	<ul style="list-style-type: none"> - Derivation of outage probabilities for small cell, macro-cells, and D2D links - Acceptance interference region algorithm proposed to guarantee the QoS for all D2D pairs in heterogeneous cellular networks - Mathematical models with SNIR, small cell density, and networks are developed -MATLAB-based simulation to validate proposed models 	<ul style="list-style-type: none"> - Improved outage probability - Enhanced QoS for all D2D pairs
[153]	<ul style="list-style-type: none"> - Investigate mobility management and its challenges with possible solution for D2D communication - Maximise control of single small cell on D2D communication 	Propose smart handover/mobility solutions to support ultra-dense networks in future 5G and beyond	-	<ul style="list-style-type: none"> - Two smart mobility methods called D2D-aware and D2D-triggered handover solutions are developed to minimise latency and reduce signalling overhead, respectively 	<ul style="list-style-type: none"> - Minimise network signalling overhead - Reduce D2D end-to-end latency - Reliable communication
[104]	Study mobility management for D2D communication in hybrid RF/VLC network	A new algorithm is proposed to manage handover signalling efficiently in hybrid RF-VLC network	Dynamic dwell timer	<ul style="list-style-type: none"> - Optimise dynamic dwell timer to allow D2D communication switching from RF to VLC link and vice versa - The switching of link depends on the results from handover delay and estimated throughput 	<ul style="list-style-type: none"> - Improved average throughput - Reduce delay

TABLE 4. (Continued.) Technical analysis and solutions for D2D communication challenges.

[35]	Review recent studies on mobility management and its influence on D2D communication	A comprehensive survey was executed to assess pressing issues and the possible solutions to promote the use of mobility to help D2D communication	-	<ul style="list-style-type: none"> - Highlight technical issues with prospective solutions - The impact of mobility in D2D communication benefits researchers to explore how mobility can assist in D2D communication - State lessons learned and open issues that warrant future work are listed - A comprehensive survey on pressing issues and viable solutions to encourage the use of mobility to help D2D communication 	Facilitates researchers to implementation and design mobility-aware-D2D communication
[154]	Deliver seamless mobility to meet QoS requirements in LTE-A and beyond networks	<ul style="list-style-type: none"> - A novel SDN-based architecture is proposed to manage D2D communications - A novel D2D handover management mechanism is devised to resolve D2D mobility problem 	-	<ul style="list-style-type: none"> - Design an enhanced D2D communication handover in SDN-based LTE-A and beyond generation architecture - Simulate the proposed SDN architecture to evaluate its performance 	<ul style="list-style-type: none"> - Reduce signalling overhead. - Enhanced D2D services continuity
[155]	Analyse past studies on D2D mobility management to overcome some challenges, such as taxonomy, RA, interference, and mode selection	<ul style="list-style-type: none"> - Provide a vision of efficient D2D mobility in 5G networks with comparison among the existing distributed mobility management methods - Present a handover performance investigation to adjust D2D communication mobility management in 5G networks 	-	<ul style="list-style-type: none"> - A comparative analysis on the existing methods used for mobility management in D2D communication - Display various D2D handover management methods and some suitable methods were selected for handover management in 5G networks - Analyse the mathematical model for handover performance - Assess handover performance mathematically and compare the selected solutions with SDN-based distributed mobility management solution 	<ul style="list-style-type: none"> - Improved handover latency - Improved packet loss - Address D2D mobility challenges as performance optimisation, seamless, automation, flexibility, and efficiency
[156]	Demonstrate contemporary studies that assist to enhance mobility management procedures in 5G HetNets	<ul style="list-style-type: none"> - Provide an overview of mobility management visions and methods used in 5G HetNets - Discuss varied handover solutions for additional investigations in the upcoming mobile communication networks - Identify challenges related to mobility management issues in 5G HetNets that may be considered for future mobile networks 	-	<ul style="list-style-type: none"> - Discuss related studies on essential concepts of mobility management in 5G HetNets - Present 5G HetNet architecture - Introduce review of mobility management in 5G HetNets - Highlight issues in mobility management implementation in 5G HetNets 	The overview should assist beginner researchers understand the mobility management concept in HetNets networks

TABLE 4. (Continued.) Technical analysis and solutions for D2D communication challenges.

[160]	Explore existing security keys in D2D communications	<ul style="list-style-type: none"> - D2D security architecture consistent with LTE scheme is proposed. - The D2D security architecture requirements are identified 	-	<ul style="list-style-type: none"> - A comprehensive study on D2D communications security - Assessed D2D security architecture, as well as identified security issues and requirements based on the study. - Examined open research problems of security in D2D communications 	Significant efforts are required to overcome D2D pair security issues
[161]	<ul style="list-style-type: none"> - Determine the security of the most popular applications in Google Play Store. - Introduce in-depth empirical security research work on mobile D2D communication networks between Android devices 	Empirically assessed the security configuration of the most famous smartphone program for mobile D2D communication networks on Android	-	<ul style="list-style-type: none"> - Perform an empirical security assessment of the mobile D2D communication framework on Android OS - Assessed four D2D communication file transfer applications used by over 1.5 billion users 	Learned security lessons and suggested potential solutions against the specified security problems
[162]	Introduce a new protocol for secure data sharing that combines the advantages of symmetric encryption and public-key cryptography, in order to conduct information security in D2D communication	<ul style="list-style-type: none"> - Secure data sharing (SeDS) is presented in D2D communication setting using cryptographic method - Explore security features in detail; assess SeDS performance of computation and communication costs; as well as availability altogether 	Protocol	<ul style="list-style-type: none"> - Incorporate PKI-based symmetric key encryption and signature to perform security purposes in D2D communication - Digital signature is utilised to realise data authority and entity authentication - Symmetric key encryption is predictable to offer data confidentiality 	The proposed protocol meets security plans in terms of entity authentication, data integrity, and confidentiality, in addition to nonrepudiation of transmission and reception

smart wearables, etc. Hence, in order to establish an efficient connection and acquire compatibility among all these different devices, a D2D heterogeneous network is needed to support multiple communication systems diversity [121], [122]. A new design of a heterogeneous wireless network between Bluetooth low energy (BLE) and Wi-Fi with a high data rate (HaLow) was studied in [160], which was achieved through a vertical handover scenario. Both BLE and HaLow technologies work on different frequency bands, and the coexistence of both diverse networks does not require an interference avoidance mechanism.

Future research will be focused on establishing a fully reliable communication link between different devices in diverse networks, which requires new transportation and translation protocols to develop a unified compatible global system, in which data sharing between various D2D users in the IoT ecosystem in UDN is facilitated.

D. MODE SELECTION

Mode selection (MS) is a critical issue in D2D communication and is an efficient method that improves energy efficiency, network throughput, and reduces interference [161], [162]. It determines whether D2D users could operate under a direct mode or cellular mode, and it could select static or dynamic time scale [163]. The selection of communication mode for DUEs is a flexible process when DUEs select the D2D mode; the latency can be reduced, and a higher spectrum resource utilization could be achieved [161]. Different DUEs model selection and algorithms have been investigated for D2D heterogeneous networks for various aims [125], [161], [164]. Three D2D communication modes can be allocated by the base station (BS) to every D2D pair, which comprises of direct D2D, local route, and relay D2D. A new optimal MS algorithm was proposed to maximize the capacity and cellular coverage in [165]. Also, the effect of MS on the adequate capacity of D2D communication has

been investigated in [166]. The development of optimal MS algorithms is an area of interest for future research directions, which not only could obtain maximum capacity, but also improve spectral efficiency and reduce system interference.

E. SECURITY

Nowadays, D2D communication network security has attracted attention due to the nature of data distribution across communication networks. D2D pairs can distribute sensitive information and data related to identifying the users and additional personal details [31], [126]. This information should be secure and safe to prevent any impersonification, eavesdropping, IP spoofing, denial of service, and malware attack by hackers for illegal purposes [32]. Accordingly, network security protocols were developed in D2D networks, which enable users to avoid information leakages.

Dynamic readjustment of D2D users due to mobility is a significant issue in establishing secure D2D communication networks. New and old D2D users may join and leave the coalition, which requires an adaptive mechanism for D2D communication security [126]. Moreover, a novel technique that utilizes interference signals as an impediment for security was introduced in [167], [168]. This was done by obstructing the eavesdropping device. Different security models and algorithms were designed to measure the security workload on heterogeneous mobile devices [169]–[171]. Besides that, an in-depth survey on security design aims was introduced in [126], [157], [172]. The survey included authentication, secure routing, key management, physical layer, access control, and additional security issues. However, many security problems remain to be discussed, which may open up many research directions in the future, and great efforts must be met to ensure D2D security.

F. MOBILITY

The users are mobile in cellular networks, and communications are automatically activated and dropped based on the D2D user's relative position. However, most research related to D2D communication concentrated on static users [173], [174]. Smart mobility solutions were proposed to mitigate the network overhead due to signaling and enhance the D2D end-to-end (E2E) latency through maximizing the time when the DUE is controlled by the small cell itself [153]. More investigation is required to explain how D2D performance increases in dynamic scenarios, and what handover and interference in the treating mechanism are needed as D2D users move across and within cells. Also, the relay or multi-hop D2D communication poses many challenges.

VI. FUTURE OF D2D COMMUNICATION IN 6G NETWORK

The sixth-generation (6G) of mobile communication is expected to launch commercially in 2030, which will allow the Internet of Everything (IoE). This will revolutionize the lifestyle, intelligent mobile society, personal life, and communication and business systems. 5G and beyond will perhaps not be able to attain all IoE requirements [175]–[178],

and this will push researchers towards looking for solutions that can meet higher demands in 6G. Many researchers in academia and industrial fields have already started visioning, planning, and aggregating requirements of 6G technologies. Also, many countries, such as China and Finland, have already begun research on 6G topics. TABLE 5 shows a comparison between 5G and the possible capabilities of future 6G.

The challenges and problems of 6G are mainly focused on energy and spectrum efficiency, capacity, and system coverage, besides movement speed and user data rate [181]. Therefore, to solve these challenges, some key technologies and novel approaches for 6G and beyond were presented, as shown in Fig.16 [176], including network slicing (NS), cognitive network (CN), mobile edge computing (MEC), Terahertz communication (THz). In addition to other technologies such as non-orthogonal multiple access (NOMA), intelligent reflecting surfaces (IRS), etc. [182].

Moreover, to fulfill the requirements of 6G, artificial intelligence (AI) will be one of the innovative techniques that can be employed to obtain maintenance, intelligent automated network processes, and management of future heterogeneous and complex 6G networks. Driven by AI techniques, D2D communication will become one of the most critical technologies in 6G networks and will play a significant role in reducing power consumption, delay, as well as improving spectrum utilization and data rate [177], [182]–[184].

Therefore, to create an efficient, intelligent D2D communication (ID2D) in the future 6G, several possible D2D communication solutions are illustrated in Fig.17. Incorporation of ID2D communication in complex 6G networks demands the potential integration of D2D with the advanced technologies mentioned above.

The efficient implementation of ID2D may require the development for at least the following techniques.

A. D2D BASED TERAHERTZ COMMUNICATION

Over the past few years, carrier frequencies that operate for wireless cellular communications have been growing to meet bandwidth requirements [185]. Researchers have proposed high frequencies, such as mm-Wave and optical wireless communication (OWC), to fulfil the exponential growth of data rate requests and to pave the route towards 5GB and 6G networks.

Terahertz (THz) frequencies (0.1-10 THz) are a promising prospect to support 5GB/6G with ultra-broadband, thus closing the gap between OWC and mmWave frequency ranges. It has been expected to provide high data rates reaching up to several Tbps, along with low latency [186], [187]. The THz can be applied in several applications, such as space communication networks, wireless mobile communication, 3D beamforming technology, wireless data centres, and automotive applications. The development of antennas using new materials and novel transceiver architectures can lead to the reality of THz communication.

A theoretical model was designed for D2D communication in THz band, which improved energy efficiency and data

TABLE 5. Comparison of 5G with possible capabilities of 6G [176], [177], [179], [180].

Main factors	5G	6G
Frequency Band(s)	30-300GHz	0.3-3THz
Network type	mm-Wave	THz wave
Maximum data rate	10[20] Gb/s	> 100Gb/s
Connection density	1 million/km2	> 10million/km2
Traffic density	10Tb/s/km2	> 100Tb/s/km2
Delay	ms level	< 1ms
Mobility	350km/h	> 1000km/h
Energy efficiency	1000x relative to 4G	> 10x relative to 5G
Spectrum efficiency	3~5x relative to 4G	> 3x relative to 5G
Positioning accuracy	Meter level	Centimeter level
Receiver sensitivity	Around -120dBm	< -130dBm
Coverage ratio	Around 70%	> 99%
Reliability	Around 99.9%	> 99.999%
Application scenarios	Massive MIMO, Macro/Pico Cell	Small Cell
Service Objects	Connection (People and Things)	Interaction (People and World)
Augmented reality for industry (capacity and peak rate)	High-level tasks/low resolution	Co-design, detailed level tasks/multi-sensory, high resolution
Time synchronization	Microseconds	Nanoseconds
Positioning and sensing	Limited automation and external sensing	Fully automated and integrated radio sensing

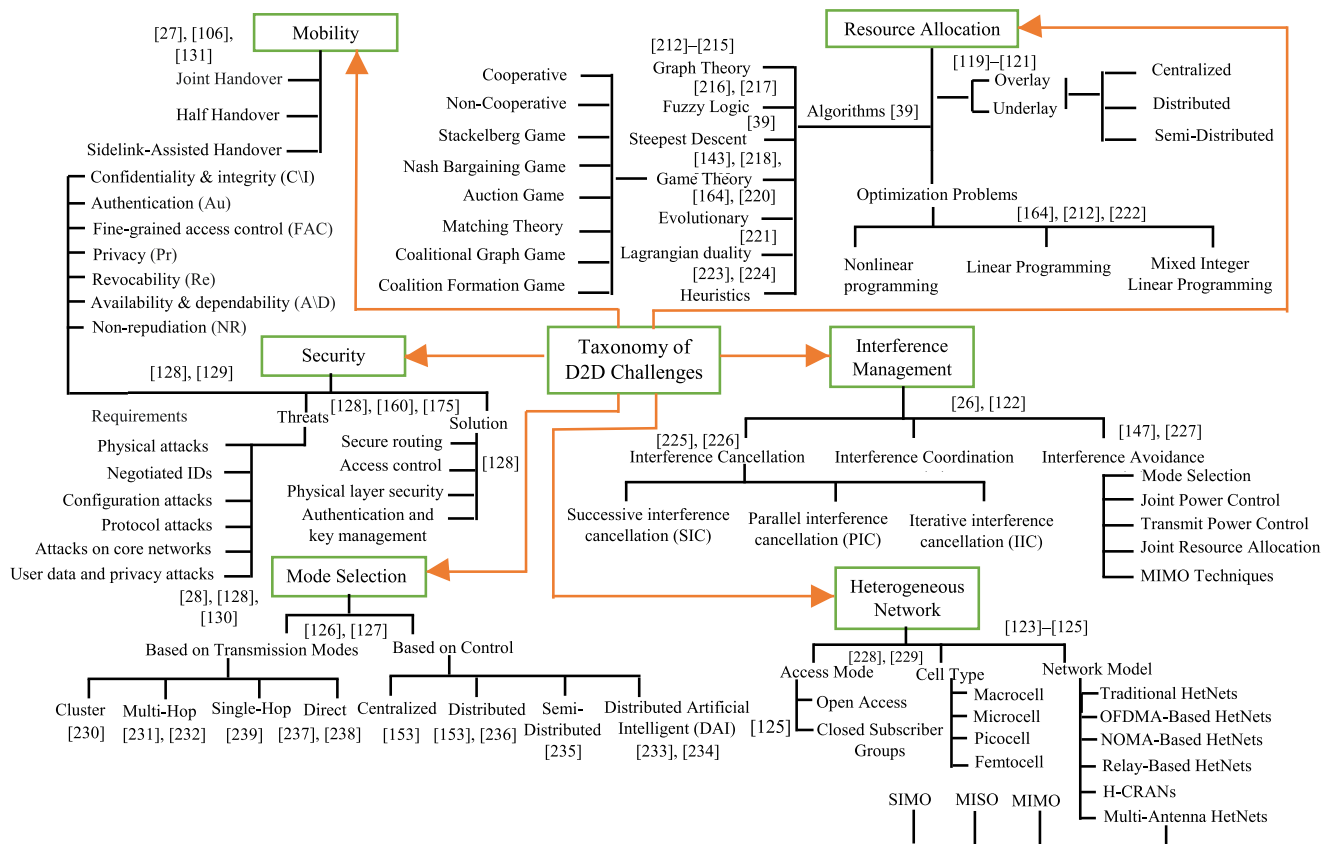

FIGURE 15. Taxonomy of D2D challenges in 5G networks.

rates [188]. A statistical 2D geometrical model was devised for short range D2D communication in THz band. A subsequent simulation was executed to verify the measurement of the proposed setup in terms of power delay profile over

excess delay [189]. Both D2D and THz have been used in indoor environments due to their restriction of transmission distances. Therefore, the integration of both technologies may cater to the upcoming 6G requirements. For future imple-

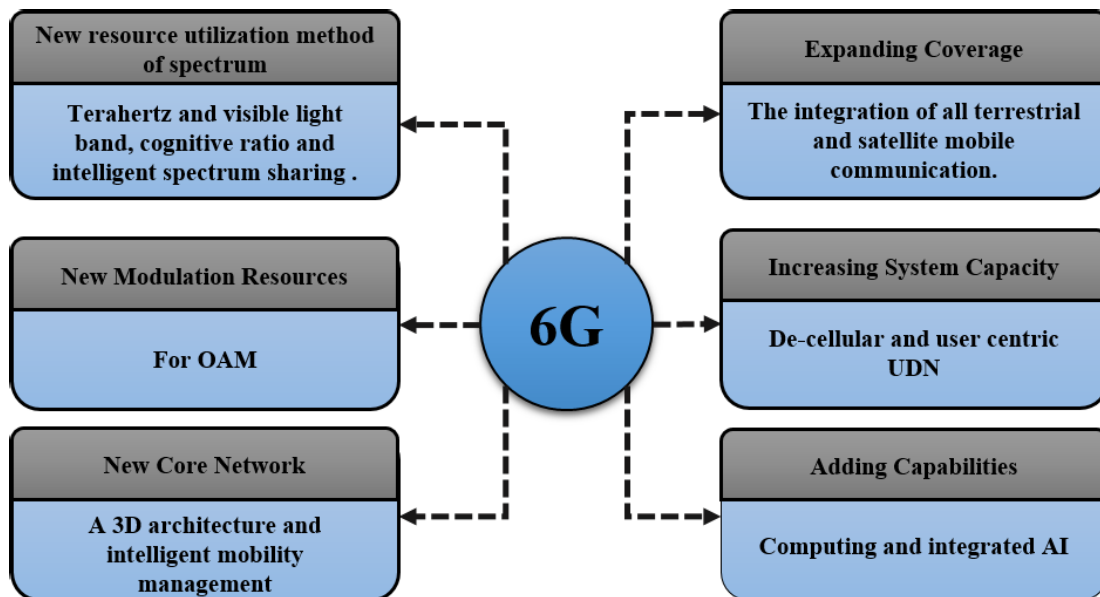

FIGURE 16. Key technologies and novel approaches for 6G and beyond [176], [180].

mentation of D2D in THz band, some key challenges of THz should be weighed in for improvement purposes. These challenges include hardware circuits of THz RF equipment, THz antennas, and THz modulator.

B. D2D-ENABLED INTELLIGENT NETWORK SLICING

The 6G networks are expected to advance flexible multi-services with a range of specifications. The division of a physical network into various virtual networks is known as network slicing (NS) [190]. It can be deployed in vehicular applications that demand high reliability, low latency, and maximum network capacity. Besides, NS is expected to reduce operational and system capital expenses, as well as offloading the core network.

The NS is the most important technology to address the variety of D2D-based services, whereby these devices can communicate with multiple NSs or specific services simultaneously [38]. The integration of NS with D2D has been envisioned to improve the system performance in several huge numbers of connected devices in varied applications. Some challenges affect the integration of D2D with NS, thus degrading the performance of the system network including interference and resource management, as well as new slice creation techniques. These challenges are bound to open the way for researchers to develop new techniques and tools for further enhancement.

C. D2D BASED COGNITIVE NETWORKING

The AI is envisioned to obtain such cognition to wireless cellular networks. The spectrum access, capacity enhancement, and energy optimisation are the most significant factors that fulfil networks beyond 5G due to the daily demand for high data rate and the number of connected devices. A cognitive

network (CN) refers to automatic network management that applied the available resources adaptively in a highly efficient manner [191]. These CNs have the potential to offer robust and adaptive communication systems through their capability to analyse and monitor the present state of the network, as well as high bandwidth. Most studies have looked into use of D2D in cellular networks with minimum interference, while research work that has incorporated D2D and CN to optimise spectrum utilisation and energy efficiency is in scarcity.

The integration of D2D with CN has been implemented for underlay cellular networks to improve spectrum efficiency and QoS [192], [193]. Besides, several models of cognitive D2D communication have been proposed to enhance energy harvesting. The incorporation of D2D with CN in 6G ecosystem is expected to offer better D2D performance, while concurrently supporting various kinds of services and applications.

D. D2D BASED INTELLIGENT REFLECTING SURFACES

In conventional wireless cellular systems, the transmitter delivers radio or electromagnetic signals to the receiver through an uncontrollable propagation atmosphere. For 5GB and 6G networks, there is fast-growing attention to develop real-time reconfigurable propagation atmospheres that enhance the communication between transmitter and receiver. This involves distributing special surfaces called intelligent reflecting surfaces (IRS) [194], [195]. The IRSs can change and control the direction of the transmitted signal using low-cost passive devices, such as phase shifters and printed dipoles [196]. The IRS is a promising candidate technology for 6G networks, mainly because it offers high energy and spectrum efficiencies, robust security, and

optimum beamforming, apart from its usage in other novel 6G applications [197].

The integration of D2D with distributed IRS is detailed in [198] to improve the transmission rate of D2D pairs, whereby significant results were reported. The IRS facilitates D2D communication based on a two-timescale optimisation algorithm by minimising the co-channel interference between D2D devices and cellular users (CUs) [199]. The IRS-based D2D communication is bound to improve wireless networks performance in 6G by smartly reconfiguring both transmission direction and atmosphere.

E. ID2D-ENHANCED MOBILE EDGE COMPUTING

Since the past few years, cloud computing (CC) has transformed the topography of information technology and turned the long-term pledge of utility computing into a truth. However, CC has failed to meet the requirements of mobility support, location awareness, and low latency [200]. Mobile edge computing (MEC) is in proximity to end-users (BS), supports mobility, and has the ability to solve the aforementioned problems. The MEC allows billions of interconnected mobile devices to conduct real-time compute-intensive implementations instantly at network edges (i.e., BS). Besides, MEC offers CC capabilities and IT service environment, which can enhance security and save mobile energy [201], [202]. The integration of D2D with MEC technologies to minimise energy consumption has been addressed in [203], whereby low complexity algorithm was initiated to overcome latency constraints.

A novel ultra-dense D2D structure for 5G MEC was proposed to enhance energy efficiency. By jointly integrating and sharing communication resources and heterogeneous computation between mobile devices, ultra-dense D2D enables a wide range of services and novel applications that require hybrid types of resources [204]. An integrated framework of D2D and MEC using OFDMA has been designed for interference management and partial offloading. The latency minimisation problem has been discussed for the integrated scenario by considering the required partial offloading, energy consumption, and resource assignment constraints [205]. The MEC promises a surprising decrease in mobile energy consumption and latency, thus the ability to address the main challenges for emerging 5GB/6G visions.

On the other hand, a new promising technology beyond D2D communication termed UAVs to everything communications abbreviated by (U2X) was introduced. A UAV aircraft that does not require a human pilot uses different sensory data to collect information and data, and then transmits it over cellular links [206]. The communication requirements of UAVs are different from sensing applications and require a flexible communication framework. Furthermore, the Internet of UAV will be a novel paradigm in the wireless communication field, in which several sensing applications could be deployed in 6G [207], [208]. Fig 17 presents a general overview of D2D communication in 6G networks. It highlights D2D concepts that could be extended from indoor environments and smart

homes to intra ship communication, building to building (B2B), manufacturing, and so on.

VII. LESSON LEARNED

This section outlines the major derived lessons learned from in-depth investigation and analyses on D2D communication at the forefront of the envisioned 5GB and 6G connectivity. The following lists the lessons captured:

A. LESSON ONE

In summary, D2D communication is a forefront candidate technology for short communications in future generations. Devices can communicate directly without relaying information signals via BS, as introduced in conventional wireless cellular networks. The D2D communication offers high power and spectral efficiencies, along with flexible infrastructure and low latency. It has been applied in many applications containing data services and local voice, online gaming, M2M, emergency networks, video streaming, and other novel applications in future generation networks.

The 5GB and 6G facilitate network connectivity among massive numbers of devices. The distribution of many small cells known as UDN can enhance D2D communication transmission delays and capacity. Some key challenges demand discussion and investigation to fulfil extraordinary capacity, data rate, and low latency for 5GB and 6G networks.

B. LESSON TWO

Rapid growth, innovations, and advancements in mobile communications technologies have led to a huge number of HetNets, which enable the connection of different devices and appliances. In order to facilitate the connection of D2D in HetNets, compatibility between devices is important to support the diversity of multiple communication systems.

C. LESSON THREE

Notably, over 70% of data traffic originates from indoor environments. The cutting-edge technologies have been reviewed to provide high speed data rates and QoS for mobile communication in 5GB and 6G networks. The integration of D2D with IoT, UDN, VLC, M2M, UAV, C-RAN, and mm-Wave could be featured and prominent to improve network performance. These integration efforts may also be the solutions to many D2D communication challenges, including resource allocation, security, interference management, model selection, and energy consumption.

D. LESSON FOUR

Employing the D2D communication technology in 6G has become attractive and garnered the attention of researchers. However, only a handful of studies have envisioned the implementation of ID2D communication in future 6G. The connectivity roadmap of ID2D communication to offer extraordinary services for various recent and future applications is discussed based on AI and new network infrastructures.

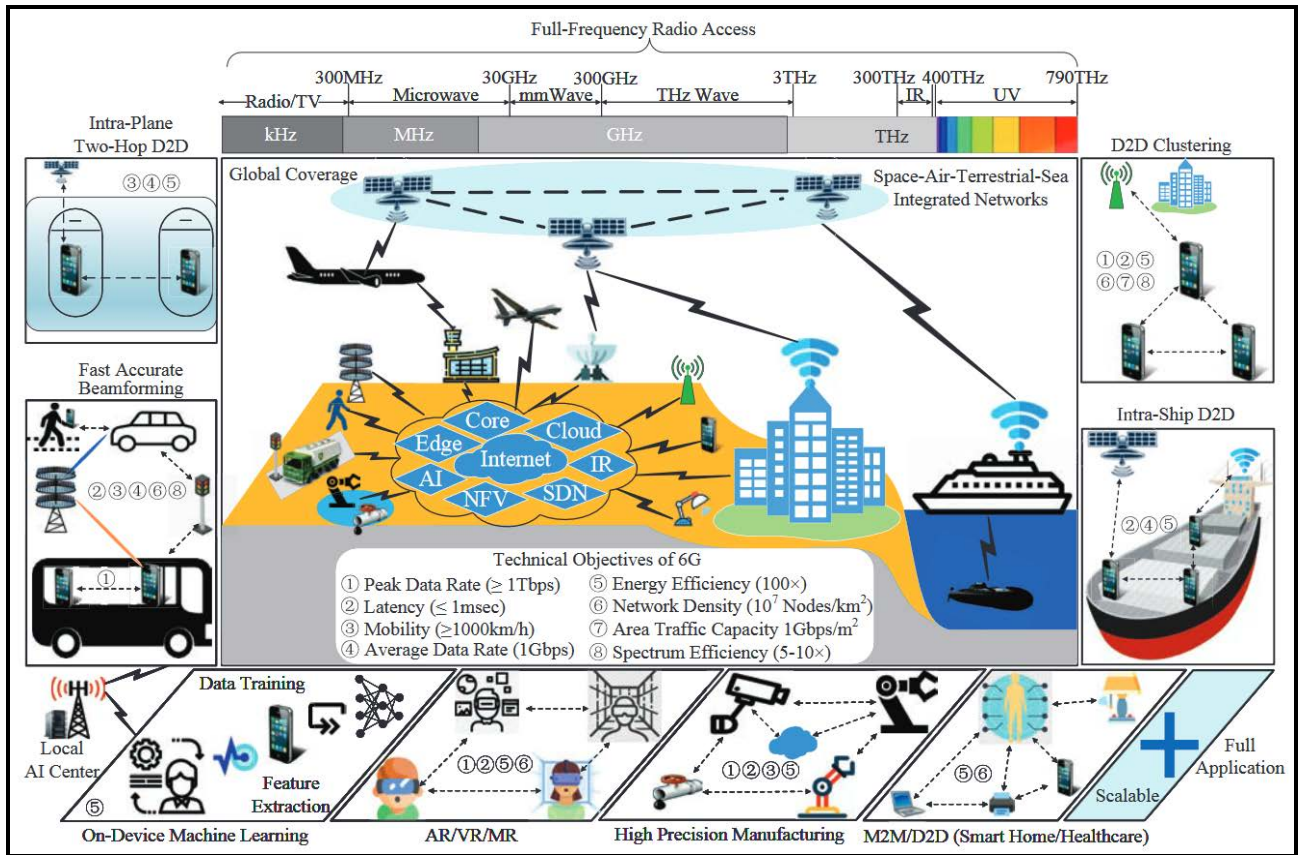

FIGURE 17. D2D communications in upcoming future space-air-terrestrial-sea integrated 6G network [182].

E. LESSON FIVE

The envisioned ID2D implemented in future 6G network is bound to offer flexible multi-services with several specifications. The efficient implementation of ID2D requires the potential incorporation of D2D with state-of-the-art technologies, such as THz, NS, CN, MEC, and IRS. These incorporations demand modification in core and access networks to produce intelligent services in future innovative infrastructures.

VIII. KEY FINDINGS AND SUGGESTIONS FOR FUTURE RESEARCH

A. REVIEW

This paper presents an in-depth review of contemporary D2D communication research work. The challenges of D2D communication in the context of 5GB and 6G are discussed with opportunities and potential possible solutions. In future, the implementation of D2D communication in realistic scenarios should be investigated to analyse its performance, while ensuring its advantages with the capability to employ D2D communication technology for novel applications in 5GB/6G networks.

B. TAXONOMY AND PAST WORK

This paper introduces D2D communication taxonomy with extensive analysis of several published work related to D2D performance in terms of interference management,

resource allocation, mode selection, mobility, heterogeneous network, and security. Various techniques, methods, and algorithms have been proposed previously to improve spectrum and energy efficiencies, data rates, throughput, and QoS. Nonetheless, the data traffic, the number of connected devices, and the need for high capacity have been increasing on daily basis, along with the existence of limitations in bandwidth or resources. Hence, more investigations on D2D communication are required to meet future 5GB/6G networks requirements.

C. HETEROGENEOUS NETWORKS

HetNets platform enables several devices with different attributes and protocols to transmit and receive data over underlay or overlay cellular networks. The D2D communication in HetNets can effectively minimise network signalling pressure and relieve BS power consumption. Hence, future research endeavour should concentrate on establishing a completely reliable D2D communication link among varying devices in diverse networks that demands new transportation and translation protocols to develop a unified compatible global system; facilitating data sharing among various D2D users in the IoT ecosystem in UDN.

D. INTEGRATION

The integration of D2D communication with other advanced technologies is foreseeable to convert future network

architectures. This integration places D2D technology at the forefront of the envisioned 5GB/6G connectivity roadmap. This paper initiates a discussion that revolves around the benefits of D2D integration with several technologies, including C-RAN, mm-Wave, IoT, VLC, UDNs, and UAVs, to support 5GB and 6G networks. Nevertheless, some of these advanced techniques face challenges as reported previously, which can deteriorate the D2D communication performance and affect the integration process. Hence, future research work should begin devising new techniques, approaches, algorithms, and tools to overcome these reported challenges for further enhancement.

E. SECURITY

Incorporating D2D communication into 5G HetNets and beyond is still in its infancy stage and faces multiple security threats. The 3GPP standardised AKA protocols are inappropriate for D2D due to dissimilarities in the communication scenario and architecture. Only aggregated signatures and cryptography have been investigated so far; signifying numerous untapped security issues that should be tackled in order to enhance security and minimise resource consumption.

In future, researchers should consider developing a novel AKA protocol for D2D pairs, besides building new security models to facilitate communication between devices in 5GB/6G HetNets.

F. AI

Artificial intelligence (AI) and machine learning (ML) are prominent technologies that have been expected to drive D2D communication in 6G networks. The implementation of efficient ID2D in 6G networks demands the incorporation with at least one of the key techniques of THz, NS, CN, IRS, and MEC. The ID2D in 6G may support the growth of novel ubiquitous intelligent applications with intelligent industries and life. Studies on ID2D in 6G networks is under discussion and more investigations are required from researchers in both academia and industries fields.

IX. CONCLUSION

D2D communication is an emerging and promising technology and is a crucial factor in fulfilling 5G generation requirements. This is due to its relatively valuable features and advantages, as mentioned earlier in the literature. In this paper, we have prepared a comprehensive survey on D2D communication and a review of contemporary research that has been done relating to D2D communication concepts, classification, and various application scenarios. Furthermore, D2D integration with other emerging technologies was thoroughly discussed as well, and suggestions for future trends were proposed. Various possible solutions for 5GB network performance improvements were presented as well. Furthermore, the main contributions of this paper are in presenting an in-depth review of problems concerning D2D communication in the context of 5GB networks and beyond. In addition,

an analysis of various published approaches related to D2D performance in terms of interference management, resource allocation, mode selection, mobility, heterogeneous network, and security was presented. The vital role that D2D communication plays in the success of upcoming 6G networks was introduced and investigated. Lastly, a direction of open research challenges of D2D communication and their possible solutions for the future was proposed.

REFERENCES

- [1] O. A. Amodu, M. Othman, N. K. Noordin, and I. Ahmad, "A primer on design aspects, recent advances, and challenges in cellular device-to-device communication," *Ad Hoc Netw.*, vol. 94, Nov. 2019, Art. no. 101938, doi: [10.1016/j.adhoc.2019.101938](https://doi.org/10.1016/j.adhoc.2019.101938).
- [2] M. S. M. Gismalla and M. F. L. Abdullah, "Device to device communication for Internet of Things ecosystem: An overview," *Int. J. Integr. Eng.*, vol. 9, no. 4, 2017.
- [3] P. Gandotra, R. K. Jha, and S. Jain, "A survey on device-to-device (D2D) communication: Architecture and security issues," *J. Netw. Comput. Appl.*, vol. 78, pp. 9–29, Jan. 2017, doi: [10.1016/j.jnca.2016.11.002](https://doi.org/10.1016/j.jnca.2016.11.002).
- [4] M. F. Hossain, A. U. Mahin, T. Debnath, F. B. Mosharraf, and K. Z. Islam, "Recent research in cloud radio access network (C-RAN) for 5G cellular systems—A survey," *J. Netw. Comput. Appl.*, vol. 139, pp. 31–48, Aug. 2019, doi: [10.1016/j.jnca.2019.04.019](https://doi.org/10.1016/j.jnca.2019.04.019).
- [5] S. J. Nawaz, S. K. Sharma, S. Wyne, M. N. Patwary, and M. Asaduzzaman, "Quantum machine learning for 6G communication networks: State-of-the-art and vision for the future," *IEEE Access*, vol. 7, pp. 46317–46350, 2019, doi: [10.1109/ACCESS.2019.2909490](https://doi.org/10.1109/ACCESS.2019.2909490).
- [6] M. M. Saeed, R. A. Saeed, and E. Saeid, "Preserving privacy of paging procedure in 5thG using identity-division multiplexing," in *Proc. 1st Int. Conf. Intell. Comput. Eng. (ICOICE)*, Dec. 2019, pp. 1–6, doi: [10.1109/ICOICE48418.2019.9035167](https://doi.org/10.1109/ICOICE48418.2019.9035167).
- [7] E. Hossain and M. Hasan, "5G cellular: Key enabling technologies and research challenges," *IEEE Instrum. Meas. Mag.*, vol. 18, no. 3, pp. 11–21, Jun. 2015, doi: [10.1109/MIM.2015.7108393](https://doi.org/10.1109/MIM.2015.7108393).
- [8] M. S. M. Gismalla, M. F. L. Abdullah, W. A. Mabrouk, B. Das, and M. I. Niass, "Data rate and BER analysis for optical attocells configuration model in visible light communication," in *Proc. Int. Conf. Inf. Sci. Commun. Technol. (ICISCT)*, Mar. 2019, pp. 1–6, doi: [10.1109/ICISCT.2019.8777433](https://doi.org/10.1109/ICISCT.2019.8777433).
- [9] M. S. M. Gismalla, M. F. L. Abdullah, M. Sami, N. S. M. Shah, B. Das, and A. A. Qasim, "Effect of optical attocells deployment on the RMSD spread in indoor visible light communication systems," in *Proc. Int. Conf. Inf. Sci. Commun. Technol. (ICISCT)*, Feb. 2020, pp. 1–6, doi: [10.1109/ICISCT49550.2020.9079939](https://doi.org/10.1109/ICISCT49550.2020.9079939).
- [10] M. Najla, P. Mach, and Z. Becvar, "Deep learning for selection between RF and VLC bands in device-to-device communication," *IEEE Wireless Commun. Lett.*, vol. 9, no. 10, pp. 1763–1767, Oct. 2020, doi: [10.1109/LWC.2020.3003786](https://doi.org/10.1109/LWC.2020.3003786).
- [11] Z. Ghassemlooy, L. N. Alves, S. Zvanovec, and M.-A. Khalighi, *Visible Light Communications: Theory and Applications*. Boca Raton, FL, USA: CRC Press, 2017.
- [12] M. Kamel, W. Hamouda, and A. Youssef, "Ultra-dense networks: A survey," *IEEE Commun. Surveys Tuts.*, vol. 18, no. 4, pp. 2522–2545, 4th Quart., 2016, doi: [10.1109/COMST.2016.2571730](https://doi.org/10.1109/COMST.2016.2571730).
- [13] S. Ullah, K. Kim, A. Manzoor, L. U. Khan, S. M. A. Kazmi, and C. S. Hong, "Quality adaptation and resource allocation for scalable video in D2D communication networks," *IEEE Access*, vol. 8, pp. 48060–48073, 2020, doi: [10.1109/ACCESS.2020.2978544](https://doi.org/10.1109/ACCESS.2020.2978544).
- [14] J. Li, G. Lei, G. Manogaran, G. Mastrokakis, and C. X. Mavroumoustakis, "D2D communication mode selection and resource optimization algorithm with optimal throughput in 5G network," *IEEE Access*, vol. 7, pp. 25263–25273, 2019, doi: [10.1109/ACCESS.2019.2900422](https://doi.org/10.1109/ACCESS.2019.2900422).
- [15] S. Kim, "A new multicasting device-to-device communication control scheme for virtualized cellular networks," *Wireless Commun. Mobile Comput.*, vol. 2019, Feb. 2019, Art. no. 3540674, doi: [10.1155/2019/3540674](https://doi.org/10.1155/2019/3540674).
- [16] M. H. Khoshafa, T. M. N. Ngatched, and M. H. Ahmed, "On the physical layer security of underlay relay-aided device-to-device communications," *IEEE Trans. Veh. Technol.*, vol. 69, no. 7, pp. 7609–7621, Jul. 2020, doi: [10.1109/TVT.2020.2994505](https://doi.org/10.1109/TVT.2020.2994505).

- [17] S. Kim, "D2D enabled cellular network spectrum allocation scheme based on the cooperative bargaining solution," *IEEE Access*, vol. 8, pp. 53710–53719, 2020, doi: [10.1109/ACCESS.2020.2981290](https://doi.org/10.1109/ACCESS.2020.2981290).
- [18] O. Hayat, Z. Kaleem, M. Zafarullah, R. Ngah, and S. Z. M. Hashim, "Signaling overhead reduction techniques in device-to-device communications: Paradigm for 5G and beyond," *IEEE Access*, vol. 9, pp. 11037–11050, 2021, doi: [10.1109/ACCESS.2021.3050106](https://doi.org/10.1109/ACCESS.2021.3050106).
- [19] M. Hicham, N. Abghour, and M. Ouzzif, "Device-to-device (D2D) communication under LTE-advanced networks," *Int. J. Wireless Mobile Netw.*, vol. 8, no. 1, pp. 11–22, Feb. 2016, doi: [10.5121/ijwmn.2016.8102](https://doi.org/10.5121/ijwmn.2016.8102).
- [20] M. Höyhtyä, O. Apilo, and M. Lasanen, "Review of latest advances in 3GPP standardization: D2D communication in 5G systems and its energy consumption models," *Future Internet*, vol. 10, no. 1, p. 3, Jan. 2018, doi: [10.3390/fi10010003](https://doi.org/10.3390/fi10010003).
- [21] N. Chukhno, S. Trilles, J. Torres-Sospedra, A. Iera, and G. Araniti, "D2D-based cooperative positioning paradigm for future wireless systems: A survey," *IEEE Sensors J.*, vol. 22, no. 6, pp. 5101–5112, Mar. 2022, doi: [10.1109/JSEN.2021.3096730](https://doi.org/10.1109/JSEN.2021.3096730).
- [22] U. N. Kar and D. K. Sanyal, "A critical review of 3GPP standardization of device-to-device communication in cellular networks," *Social Netw. Comput. Sci.*, vol. 1, no. 1, p. 37, Jan. 2020, doi: [10.1007/s42979-019-0045-5](https://doi.org/10.1007/s42979-019-0045-5).
- [23] M. Harounabadi, D. M. Soleymani, S. Bhadauria, M. Leyh, and E. Roth-Mandutz, "V2X in 3GPP standardization: NR sidelink in release-16 and beyond," *IEEE Commun. Standards Mag.*, vol. 5, no. 1, pp. 12–21, Mar. 2021, doi: [10.1109/MCOMSTD.001.2000070](https://doi.org/10.1109/MCOMSTD.001.2000070).
- [24] E. Katranaras, M. Dillinger, T. Abbas, R. Theillaud, J. L. Calvo, and Y. Zang, "Standardization and regulation," in *Cellular V2X for Connected Automated Driving*, 2021, pp. 63–90, doi: [10.1002/9781119692676.ch3](https://doi.org/10.1002/9781119692676.ch3).
- [25] T. Jiang, J. Zhang, P. Tang, and L. Tian, "3GPP standardized 5G channel model for IIoT scenarios: A survey," *IEEE Internet Things J.*, vol. 8, no. 11, pp. 8799–8815, Jan. 2021, doi: [10.1109/JIOT.2020.3048992](https://doi.org/10.1109/JIOT.2020.3048992).
- [26] M. H. Adnan and Z. Ahmad Zukarnain, "Device-to-device communication in 5G environment: Issues, solutions, and challenges," *Symmetry*, vol. 12, no. 11, p. 1762, Oct. 2020, doi: [10.3390/sym12111762](https://doi.org/10.3390/sym12111762).
- [27] P. Gandotra and R. K. Jha, "Device-to-device communication in cellular networks: A survey," *J. Netw. Comput. Appl.*, vol. 71, pp. 99–117, Aug. 2016, doi: [10.1016/j.jnca.2016.06.004](https://doi.org/10.1016/j.jnca.2016.06.004).
- [28] M. Haus, M. Waqas, A. Y. Ding, Y. Li, S. Tarkoma, and J. Ott, "Security and privacy in device-to-device (D2D) communication: A review," *IEEE Commun. Surveys Tuts.*, vol. 19, no. 2, pp. 1054–1079, 2nd Quart., 2017, doi: [10.1109/COMST.2017.2649687](https://doi.org/10.1109/COMST.2017.2649687).
- [29] S. Yu, W. Ejaz, L. Guan, and A. Anpalagan, "Resource allocation schemes in D2D communications: Overview, classification, and challenges," *Wireless Pers. Commun.*, vol. 96, no. 1, pp. 303–322, 2017, doi: [10.1007/s11277-017-4168-5](https://doi.org/10.1007/s11277-017-4168-5).
- [30] M. Ahmad, M. Azam, M. Naeem, M. Iqbal, A. Anpalagan, and M. Haneef, "Resource management in D2D communication: An optimization perspective," *J. Netw. Comput. Appl.*, vol. 93, pp. 51–75, Sep. 2017, doi: [10.1016/j.jnca.2017.03.017](https://doi.org/10.1016/j.jnca.2017.03.017).
- [31] R. I. Ansari, C. Chrysostomou, and S. A. Hassan, "5G D2D networks: Techniques, challenges, and future prospects," *IEEE Syst. J.*, vol. 12, no. 4, pp. 3970–3984, Dec. 2018, doi: [10.1109/JSYST.2017.2773633](https://doi.org/10.1109/JSYST.2017.2773633).
- [32] U. N. Kar and D. K. Sanyal, "An overview of device-to-device communication in cellular networks," *ICT Exp.*, vol. 4, no. 4, pp. 203–208, Dec. 2018, doi: [10.1016/j.ict.2017.08.002](https://doi.org/10.1016/j.ict.2017.08.002).
- [33] M. Ahmed, Y. Li, M. Waqas, M. Sheraz, D. Jin, and Z. Han, "A survey on socially aware device-to-device communications," *IEEE Commun. Surveys Tuts.*, vol. 20, no. 3, pp. 2169–2197, 3rd Quart., 2018, doi: [10.1109/COMST.2018.2820069](https://doi.org/10.1109/COMST.2018.2820069).
- [34] M. Nitti, G. A. Stelea, V. Popescu, and M. Fadda, "When social networks meet D2D communications: A survey," *Sensors*, vol. 19, no. 2, p. 396, 2019, doi: [10.3390/s19020396](https://doi.org/10.3390/s19020396).
- [35] M. Waqas, Y. Niu, Y. Li, M. Ahmed, D. Jin, S. Chen, and Z. Han, "A comprehensive survey on mobility-aware D2D communications: Principles, practice and challenges," *IEEE Commun. Surveys Tuts.*, vol. 22, no. 3, pp. 1863–1886, 3rd Quart., 2020, doi: [10.1109/COMST.2019.2923708](https://doi.org/10.1109/COMST.2019.2923708).
- [36] P. K. Malik, D. S. Wadhwa, and J. S. Khinda, "A survey of device to device and cooperative communication for the future cellular networks," *Int. J. Wireless Inf. Netw.*, vol. 27, no. 3, pp. 411–432, Sep. 2020, doi: [10.1007/s10776-020-00482-8](https://doi.org/10.1007/s10776-020-00482-8).
- [37] D. Prerna, R. Tekchandani, and N. Kumar, "Device-to-device content caching techniques in 5G: A taxonomy, solutions, and challenges," *Comput. Commun.*, vol. 153, pp. 48–84, Mar. 2020, doi: [10.1016/j.comcom.2020.01.057](https://doi.org/10.1016/j.comcom.2020.01.057).
- [38] L. Nadeem, M. A. Azam, Y. Amin, M. A. Al-Ghamdi, K. K. Chai, M. F. N. Khan, and M. A. Khan, "Integration of D2D, network slicing, and MEC in 5G cellular networks: Survey and challenges," *IEEE Access*, vol. 9, pp. 37590–37612, 2021, doi: [10.1109/ACCESS.2021.3063104](https://doi.org/10.1109/ACCESS.2021.3063104).
- [39] S. Jayakumar, "A review on resource allocation techniques in D2D communication for 5G and B5G technology," *Peer-Peer Netw. Appl.*, vol. 14, no. 1, pp. 243–269, Jan. 2021, doi: [10.1007/s12083-020-00962-x](https://doi.org/10.1007/s12083-020-00962-x).
- [40] R. Borralho, A. Mohamed, A. U. Quddus, P. Vieira, and R. Tafazolli, "A survey on coverage enhancement in cellular networks: Challenges and solutions for future deployments," *IEEE Commun. Surveys Tuts.*, vol. 23, no. 2, pp. 1302–1341, 2nd Quart., 2021, doi: [10.1109/COMST.2021.3053464](https://doi.org/10.1109/COMST.2021.3053464).
- [41] A. N. Ibrahim, M. F. L. Abdullah, and M. S. M. Gismalla, "Basic of 5G networks," in *Advanced Wireless Sensing Techniques for 5G Networks*. Boca Raton, FL, USA: CRC Press, 2018, pp. 19–44.
- [42] M. S. M. Gismalla and M. F. L. Abdullah, "Survey on device-to-device communication with Internet of Things in cellular networks," *J. Appl. Eng. Technol.*, vol. 1, no. 1, pp. 1–7, 2017.
- [43] F. Jameel, Z. Hamid, F. Jabeen, S. Zeadally, and M. A. Javed, "A survey of device-to-device communications: Research issues and challenges," *IEEE Commun. Surveys Tuts.*, vol. 20, no. 3, pp. 2133–2168, 3rd Quart., 2018, doi: [10.1109/COMST.2018.2828120](https://doi.org/10.1109/COMST.2018.2828120).
- [44] S. Hashima, B. M. ElHalawany, K. Hatano, K. Wu, and E. M. Mohamed, "Leveraging machine-learning for D2D communications in 5G/beyond 5G networks," *Electronics*, vol. 10, no. 2, p. 169, Jan. 2021, doi: [10.3390/electronics10020169](https://doi.org/10.3390/electronics10020169).
- [45] J. Iqbal, M. A. Iqbal, A. Ahmad, M. Khan, A. Qamar, and K. Han, "Comparison of spectral efficiency techniques in device-to-device communication for 5G," *IEEE Access*, vol. 7, pp. 57440–57449, 2019, doi: [10.1109/ACCESS.2019.2914486](https://doi.org/10.1109/ACCESS.2019.2914486).
- [46] D. Wang, H. Qin, B. Song, K. Xu, X. Du, and M. Guizani, "Joint resource allocation and power control for D2D communication with deep reinforcement learning in MCC," *Phys. Commun.*, vol. 45, Apr. 2021, Art. no. 101262, doi: [10.1016/j.phycom.2020.101262](https://doi.org/10.1016/j.phycom.2020.101262).
- [47] D. S. Gurjar and P. K. Upadhyay, "Overlay device-to-device communications in asymmetric two-way cellular systems with hybrid relaying," *IEEE Syst. J.*, vol. 12, no. 4, pp. 3713–3724, Dec. 2018, doi: [10.1109/JSYST.2017.2783372](https://doi.org/10.1109/JSYST.2017.2783372).
- [48] O. Hayat, R. Ngah, and Y. Zahedi, "In-band device to device (D2D) communication and device discovery: A survey," *Wireless Pers. Commun.*, vol. 106, no. 2, pp. 451–472, May 2019, doi: [10.1007/s11277-019-06173-9](https://doi.org/10.1007/s11277-019-06173-9).
- [49] Z. Li, J. Gui, N. Xiong, and Z. Zeng, "Energy-efficient resource sharing scheme with out-band D2D relay-aided communications in C-RAN-based underlay cellular networks," *IEEE Access*, vol. 7, pp. 19125–19142, 2019, doi: [10.1109/ACCESS.2019.2891670](https://doi.org/10.1109/ACCESS.2019.2891670).
- [50] H. H. Hussein, H. A. Elsayed, and S. M. Abd El-kader, "Intensive benchmarking of D2D communication over 5G cellular networks: Prototype, integrated features, challenges, and main applications," *Wireless Netw.*, vol. 26, no. 5, pp. 3183–3202, Jul. 2020, doi: [10.1007/s11276-019-02131-2](https://doi.org/10.1007/s11276-019-02131-2).
- [51] C. Chakraborty and J. J. C. P. Rodrigues, "A comprehensive review on device-to-device communication paradigm: Trends, challenges and applications," *Wireless Pers. Commun.*, vol. 114, no. 1, pp. 185–207, Sep. 2020, doi: [10.1007/s11277-020-07358-3](https://doi.org/10.1007/s11277-020-07358-3).
- [52] E. K. K. Edris, M. Aiash, and J. Loo, "Investigating network services abstraction in 5G enabled device-to-device (D2D) communications," in *Proc. IEEE SmartWorld, Ubiquitous Intell. Comput., Adv. Trusted Comput., Scalable Comput. Commun., Cloud Big Data Comput., Internet People Smart City Innov. SmartWorld/SCALCOM/UIC/ATC/CBDCom/IOP/SCI*, Aug. 2019, pp. 1660–1665, doi: [10.1109/SmartWorld-UIC-ATC-SCALCOM-IOP-SCI.2019.00296](https://doi.org/10.1109/SmartWorld-UIC-ATC-SCALCOM-IOP-SCI.2019.00296).
- [53] M. Abbasi, A. Shahraki, H. R. Barzegar, and C. Pahl, "Synchronization techniques in 'device to device-and vehicle to vehicle-enabled' cellular networks: A survey," *Comput. Elect. Eng.*, vol. 90, Mar. 2021, Art. no. 106955, doi: [10.1016/j.compeleceng.2020.106955](https://doi.org/10.1016/j.compeleceng.2020.106955).

- [54] D. Liu, Y. Xu, J. Wang, J. Chen, Q. Wu, A. Anpalagan, K. Xu, and Y. Zhang, "Opportunistic utilization of dynamic multi-UAV in device-to-device communication networks," *IEEE Trans. Cognit. Commun. Netw.*, vol. 6, no. 3, pp. 1069–1083, Sep. 2020, doi: [10.1109/TCCN.2020.2991436](https://doi.org/10.1109/TCCN.2020.2991436).
- [55] S. Pizzi, C. Suraci, A. Iera, A. Molinaro, and G. Araniti, "A sidelink-aided approach for secure multicast service delivery: From human-oriented multimedia traffic to machine type communications," *IEEE Trans. Broadcast.*, vol. 67, no. 1, pp. 313–323, Mar. 2021, doi: [10.1109/TBC.2020.2977512](https://doi.org/10.1109/TBC.2020.2977512).
- [56] S. W. H. Shah, A. N. Mian, and J. Crowcroft, "Statistical QoS guarantees for licensed-unlicensed spectrum interoperable D2D communication," *IEEE Access*, vol. 8, pp. 27277–27290, 2020, doi: [10.1109/ACCESS.2020.2970829](https://doi.org/10.1109/ACCESS.2020.2970829).
- [57] Y.-N. Dong, J.-J. Zhao, and J. Jin, "Novel feature selection and classification of internet video traffic based on a hierarchical scheme," *Comput. Netw.*, vol. 119, pp. 102–111, Jun. 2017, doi: [10.1016/j.comnet.2017.03.019](https://doi.org/10.1016/j.comnet.2017.03.019).
- [58] H. Zhu, Y. Cao, W. Wang, B. Liu, and T. Jiang, "QoE-aware resource allocation for adaptive device-to-device video streaming," *IEEE Netw.*, vol. 29, no. 6, pp. 6–12, Nov. 2015, doi: [10.1109/MNET.2015.7340418](https://doi.org/10.1109/MNET.2015.7340418).
- [59] I. Ahmed, M. H. Ismail, and M. S. Hassan, "Video transmission using device-to-device communications: A survey," *IEEE Access*, vol. 7, pp. 131019–131038, 2019, doi: [10.1109/ACCESS.2019.2940595](https://doi.org/10.1109/ACCESS.2019.2940595).
- [60] N. Anjum, Z. Yang, H. Saki, M. Kiran, and M. Shikh-Bahaei, "Device-to-device (D2D) communication as a bootstrapping system in a wireless cellular network," *IEEE Access*, vol. 7, pp. 6661–6678, 2019, doi: [10.1109/ACCESS.2019.2890987](https://doi.org/10.1109/ACCESS.2019.2890987).
- [61] A. Lo, Y. Law, and M. Jacobsson, "A cellular-centric service architecture for machine-to-machine (M2M) communications," *IEEE Wireless Commun.*, vol. 20, no. 5, pp. 143–151, Oct. 2013, doi: [10.1109/MWC.2013.6664485](https://doi.org/10.1109/MWC.2013.6664485).
- [62] A. Ali, G. A. Shah, and J. Arshad, "Energy efficient techniques for M2M communication: A survey," *J. Netw. Comput. Appl.*, vol. 68, pp. 42–55, Jun. 2016, doi: [10.1016/j.jnca.2016.04.002](https://doi.org/10.1016/j.jnca.2016.04.002).
- [63] P. K. Verma, R. Verma, A. Prakash, and A. Agrawal, "Machine-to-machine (M2M) communications: A survey," *J. Netw. Comput. Appl.*, vol. 66, pp. 83–105, May 2016, doi: [10.1016/j.jnca.2016.02.016](https://doi.org/10.1016/j.jnca.2016.02.016).
- [64] Z. Zhou, C. Zhang, J. Wang, and B. Gu, "Energy-efficient resource allocation for energy harvesting-based cognitive machine-to-machine communications," *IEEE Trans. Cognit. Commun. Netw.*, vol. 5, no. 3, pp. 595–607, Sep. 2019, doi: [10.1109/TCCN.2019.2925025](https://doi.org/10.1109/TCCN.2019.2925025).
- [65] H. Yuan, W. Guo, and S. Wang, "Emergency route selection for D2D cellular communications during an urban terrorist attack," in *Proc. IEEE Int. Conf. Commun. Workshops (ICC)*, Jun. 2014, pp. 237–242, doi: [10.1109/ICCW.2014.6881202](https://doi.org/10.1109/ICCW.2014.6881202).
- [66] L. Shi, Z. Jiang, and S. Xu, "Throughput-aware path planning for UAVs in D2D 5G networks," *Ad Hoc Netw.*, vol. 116, May 2021, Art. no. 102427, doi: [10.1016/j.adhoc.2021.102427](https://doi.org/10.1016/j.adhoc.2021.102427).
- [67] N. Zhao, W. Lu, M. Sheng, Y. Chen, and J. Tang, "UAV-assisted emergency networks in disasters," *IEEE Wireless Commun.*, vol. 26, no. 1, pp. 45–51, Feb. 2019, doi: [10.1109/MWC.2018.1800160](https://doi.org/10.1109/MWC.2018.1800160).
- [68] S. Singh, N. Saxena, A. Roy, and H. Kim, "A survey on 5G network technologies from social perspective," *IETE Tech. Rev.*, vol. 34, no. 1, pp. 30–39, Jan. 2017, doi: [10.1080/02564602.2016.1141077](https://doi.org/10.1080/02564602.2016.1141077).
- [69] N. T. Le, M. A. Hossain, A. Islam, D.-Y. Kim, Y.-J. Choi, and Y. M. Jang, "Survey of promising technologies for 5G networks," *Mobile Inf. Syst.*, vol. 2016, pp. 1–25, 2016, doi: [10.1155/2016/2676589](https://doi.org/10.1155/2016/2676589).
- [70] K. Wang, K. Yang, and C. S. Magurawalage, "Joint energy minimization and resource allocation in C-RAN with mobile cloud," *IEEE Trans. Cloud Comput.*, vol. 6, no. 3, pp. 760–770, Jul. 2018, doi: [10.1109/TCC.2016.2522439](https://doi.org/10.1109/TCC.2016.2522439).
- [71] J. Wu, Z. Zhang, Y. Hong, and Y. Wen, "Cloud radio access network (C-RAN): A primer," *IEEE Netw.*, vol. 29, no. 1, pp. 35–41, Jan. 2015, doi: [10.1109/MNET.2015.7018201](https://doi.org/10.1109/MNET.2015.7018201).
- [72] L. Ferdouse, A. Anpalagan, and S. Erkućuk, "Joint communication and computing resource allocation in 5G cloud radio access networks," *IEEE Trans. Veh. Technol.*, vol. 68, no. 9, pp. 9122–9135, Sep. 2019, doi: [10.1109/TVT.2019.2927904](https://doi.org/10.1109/TVT.2019.2927904).
- [73] P. Patil and W. Yu, "Generalized compression strategy for the downlink cloud radio access network," *IEEE Trans. Inf. Theory*, vol. 65, no. 10, pp. 6766–6780, Oct. 2019, doi: [10.1109/TIT.2019.2930568](https://doi.org/10.1109/TIT.2019.2930568).
- [74] I. El Bakoury and B. Nazer, "Integer-forcing architectures for uplink cloud radio access networks," *IEEE Trans. Wireless Commun.*, vol. 19, no. 4, pp. 2336–2351, Apr. 2020, doi: [10.1109/TWC.2019.2963878](https://doi.org/10.1109/TWC.2019.2963878).
- [75] K. M. S. Huq, S. Mumtaz, J. Rodriguez, P. Marques, B. Okyere, and V. Frascolla, "Enhanced C-RAN using D2D network," *IEEE Commun. Mag.*, vol. 55, no. 3, pp. 100–107, Mar. 2017, doi: [10.1109/MCOM.2017.1600497CM](https://doi.org/10.1109/MCOM.2017.1600497CM).
- [76] L. Wei, R. Hu, Y. Qian, and G. Wu, "Key elements to enable millimeter wave communications for 5G wireless systems," *IEEE Wireless Commun.*, vol. 21, no. 6, pp. 136–143, Dec. 2014, doi: [10.1109/MWC.2014.7000981](https://doi.org/10.1109/MWC.2014.7000981).
- [77] M. S. Al-Abiad and M. J. Hossain, "Completion time minimization in fog-RANs using D2D communications and rate-aware network coding," *IEEE Trans. Wireless Commun.*, vol. 20, no. 6, pp. 3831–3846, Jun. 2021, doi: [10.1109/TWC.2021.3053940](https://doi.org/10.1109/TWC.2021.3053940).
- [78] I. J. Ranawaka, K. T. Hemachandra, T. Samarasinghe, and T. Nuradha, "An energy efficient D2D model with guaranteed quality of service for cloud radio access networks," in *Proc. 22nd Int. Symp. Wireless Pers. Multimedia Commun. (WPMC)*, Nov. 2019, pp. 1–6, doi: [10.1109/WPMC48795.2019.9096086](https://doi.org/10.1109/WPMC48795.2019.9096086).
- [79] Y. Mo, M. Peng, H. Xiang, Y. Sun, and X. Ji, "Resource allocation in cloud radio access networks with device-to-device communications," *IEEE Access*, vol. 5, pp. 1250–1262, 2017, doi: [10.1109/ACCESS.2017.2669220](https://doi.org/10.1109/ACCESS.2017.2669220).
- [80] B. Zhang, X. Mao, and J.-L. Yu, "Resource allocation for 5G heterogeneous cloud radio access networks with D2D communication: A matching and coalition approach," *IEEE Trans. Veh. Technol.*, vol. 67, no. 7, pp. 5883–5894, Jul. 2018, doi: [10.1109/TVT.2018.2802900](https://doi.org/10.1109/TVT.2018.2802900).
- [81] N. Al-Falahy and O. Y. K. Alani, "Millimetre wave frequency band as a candidate spectrum for 5G network architecture: A survey," *Phys. Commun.*, vol. 32, pp. 120–144, Feb. 2019, doi: [10.1016/j.phycom.2018.11.003](https://doi.org/10.1016/j.phycom.2018.11.003).
- [82] N. Deng, M. Haenggi, and Y. Sun, "Millimeter-wave device-to-device networks with heterogeneous antenna arrays," *IEEE Trans. Commun.*, vol. 66, no. 9, pp. 4271–4285, Sep. 2018, doi: [10.1109/TCOMM.2018.2824807](https://doi.org/10.1109/TCOMM.2018.2824807).
- [83] M. A. H. Mitul and M. M. Mowla, "A distributed method analysis for enabling device-to-device communications in millimeter wave bands," in *Proc. Int. Conf. Comput., Commun., Chem., Mater. Electron. Eng. (IC4ME2)*, Jul. 2019, pp. 1–4, doi: [10.1109/IC4ME247184.2019.9036505](https://doi.org/10.1109/IC4ME247184.2019.9036505).
- [84] C. Zhang, W. Zhang, W. Wang, L. Yang, and W. Zhang, "Research challenges and opportunities of UAV millimeter-wave communications," *IEEE Wireless Commun.*, vol. 26, no. 1, pp. 58–62, Feb. 2019, doi: [10.1109/MWC.2018.1800214](https://doi.org/10.1109/MWC.2018.1800214).
- [85] N. Zabetian, A. Mohammadi, and M. Kazemi, "Energy efficiency optimization for device-to-device communication underlying cellular networks in millimeter-wave," *Int. J. Commun. Syst.*, vol. 33, no. 6, p. e4287, Apr. 2020, doi: [10.1002/dac.4287](https://doi.org/10.1002/dac.4287).
- [86] R. D. Govenker, A. Y. Phatak, R. Bajpai, and N. Gupta, "Outage analysis of mmWave integrated device-to-device communication system under Nakagami fading channel," in *Proc. Nat. Conf. Commun. (NCC)*, Feb. 2020, pp. 1–6, doi: [10.1109/NCC48643.2020.9056087](https://doi.org/10.1109/NCC48643.2020.9056087).
- [87] S. G. Hong, J. Park, and S. Bahk, "Subchannel and power allocation for D2D communication in mmWave cellular networks," *J. Commun. Netw.*, vol. 22, no. 2, pp. 118–129, Apr. 2020, doi: [10.1109/JCN.2020.0000007](https://doi.org/10.1109/JCN.2020.0000007).
- [88] O. Yazdani, G. Mirjalili, and M. Monemi, "Efficient transmit antenna selection and resource allocation scheme for mmWave D2D networks," *AEU-Int. J. Electron. Commun.*, vol. 123, Aug. 2020, Art. no. 153271, doi: [10.1016/j.aeue.2020.153271](https://doi.org/10.1016/j.aeue.2020.153271).
- [89] F. O. Ombongi, A. Ouma, and P. Kibet, "Performance analysis for millimeter wave device-to-device communication networks: A review," in *Proc. Sustain. Res. Innov. Conf.*, 2020, pp. 132–141.
- [90] O. Bello, S. Zeadally, and M. Badra, "Network layer inter-operation of device-to-device communication technologies in Internet of Things (IoT)," *Ad Hoc Netw. J.*, vol. 57, pp. 52–62, Mar. 2017, doi: [10.1016/j.adhoc.2016.06.010](https://doi.org/10.1016/j.adhoc.2016.06.010).
- [91] M. A. Kandil, H. Lakhlef, A. Bouabdallah, and Y. Challal, "A versatile key management protocol for secure group and device-to-device communication in the Internet of Things," *J. Netw. Comput. Appl.*, vol. 150, Jan. 2020, Art. no. 102480, doi: [10.1016/j.jnca.2019.102480](https://doi.org/10.1016/j.jnca.2019.102480).

- [92] B. M. ElHalawany, R. Ruby, and K. Wu, "D2D communication for enabling Internet-of-Things: Outage probability analysis," *IEEE Trans. Veh. Technol.*, vol. 68, no. 3, pp. 2332–2345, Mar. 2019, doi: [10.1109/TVT.2019.2891648](https://doi.org/10.1109/TVT.2019.2891648).
- [93] P. Pawar and A. Trivedi, "Device-to-device communication based IoT system: Benefits and challenges," *IETE Tech. Rev.*, vol. 36, no. 4, pp. 362–374, Jul. 2019, doi: [10.1080/02564602.2018.1476191](https://doi.org/10.1080/02564602.2018.1476191).
- [94] L. Militano, G. Araniti, M. Condoluci, I. Farris, and A. Iera, "Device-to-device communications for 5G Internet of Things," *EAI Endorsed Trans. Internet Things*, vol. 1, no. 1, Oct. 2015, Art. no. 150598, doi: [10.4108/eai.26-10-2015.150598](https://doi.org/10.4108/eai.26-10-2015.150598).
- [95] M. S. M. Gismalla, M. F. L. Abdullah, B. Das, W. A. Mabrouk, and N. E. Mahfouz, "Design of an optical attocells configuration for an indoor visible light communications system," *AEU-Int. J. Electron. Commun.*, vol. 112, Dec. 2019, Art. no. 152946, doi: [10.1016/j.aecu.2019.152946](https://doi.org/10.1016/j.aecu.2019.152946).
- [96] H. Zhang, W. Ding, F. Yang, J. Song, and Z. Han, "Resource allocation in heterogeneous network with visible light communication and D2D: A hierarchical game approach," *IEEE Trans. Commun.*, vol. 67, no. 11, pp. 7616–7628, Nov. 2019, doi: [10.1109/TCOMM.2019.2936849](https://doi.org/10.1109/TCOMM.2019.2936849).
- [97] M. S. M. Gismalla, M. F. L. Abdullah, M. S. Ahmed, W. A. Mabrouk, and A.-F. Najib, "Design and analysis of different optical attocells deployment models for indoor visible light communication system," *Int. J. Integr. Eng.*, vol. 13, no. 6, pp. 253–264, 2021.
- [98] M. S. M. Gismalla, M. F. L. Abdullah, M. I. Niass, B. Das, and W. A. Mabrouk, "Improve uniformity for an indoor visible light communication system," *Int. J. Commun. Syst.*, vol. 33, no. 8, p. e4349, May 2020, doi: [10.1002/dac.4349](https://doi.org/10.1002/dac.4349).
- [99] M. S. M. Gismalla and M. F. L. Abdullah, "Optimization of received power and SNR for an indoor attocells network in visible light communication," *J. Commun.*, vol. 14, no. 1, pp. 64–69, 2019, doi: [10.12720/jcm.14.1.64-69](https://doi.org/10.12720/jcm.14.1.64-69).
- [100] H. Burchardt, N. Serafimovski, D. Tsonev, S. Videv, and H. Haas, "VLC: Beyond point-to-point communication," *IEEE Commun. Mag.*, vol. 52, no. 7, pp. 98–105, Jul. 2014, doi: [10.1109/MCOM.2014.6852089](https://doi.org/10.1109/MCOM.2014.6852089).
- [101] D. Tsonev, S. Videv, and H. Haas, "Light fidelity (Li-Fi): Towards all-optical networking," *Proc. SPIE*, vol. 9007, Feb. 2014, Art. no. 900702.
- [102] Z. Becvar, M. Najla, and P. Mach, "Selection between radio frequency and visible light communication bands for D2D," in *Proc. IEEE 87th Veh. Technol. Conf. (VTC Spring)*, Jun. 2018, pp. 1–7, doi: [10.1109/VTC-Spring.2018.8417703](https://doi.org/10.1109/VTC-Spring.2018.8417703).
- [103] P. Mach, Z. Becvar, M. Najla, and S. Zvanovec, "Combination of visible light and radio frequency bands for device-to-device communication," in *Proc. IEEE 28th Annu. Int. Symp. Pers., Indoor, Mobile Radio Commun. (PIMRC)*, Oct. 2017, pp. 1–7, doi: [10.1109/PIMRC.2017.8292746](https://doi.org/10.1109/PIMRC.2017.8292746).
- [104] Z. Becvar, R.-G. Cheng, M. Charvat, and P. Mach, "Mobility management for D2D communication combining radio frequency and visible light communications bands," *Wireless Netw.*, vol. 26, no. 7, pp. 5473–5484, Oct. 2020, doi: [10.1007/s11276-020-02408-x](https://doi.org/10.1007/s11276-020-02408-x).
- [105] M. Najla, P. Mach, Z. Becvar, P. Chvojka, and S. Zvanovec, "Efficient exploitation of radio frequency and visible light communication bands for D2D in mobile networks," *IEEE Access*, vol. 7, pp. 168922–168933, 2019, doi: [10.1109/ACCESS.2019.2954049](https://doi.org/10.1109/ACCESS.2019.2954049).
- [106] M. A. Adedoyin and O. E. Falowo, "Combination of ultra-dense networks and other 5G enabling technologies: A survey," *IEEE Access*, vol. 8, pp. 22893–22932, 2020, doi: [10.1109/ACCESS.2020.2969980](https://doi.org/10.1109/ACCESS.2020.2969980).
- [107] O. Alamu, A. Gbenga-Ilori, M. Adelabu, A. Imoize, and O. Ladipo, "Energy efficiency techniques in ultra-dense wireless heterogeneous networks: An overview and outlook," *Eng. Sci. Technol., Int. J.*, vol. 23, no. 6, pp. 1308–1326, Dec. 2020, doi: [10.1016/j.jestech.2020.05.001](https://doi.org/10.1016/j.jestech.2020.05.001).
- [108] M. F. Hashim and N. I. A. Razak, "Ultra-dense networks: Integration with device to device (D2D) communication," *Wireless Pers. Commun.*, vol. 106, no. 2, pp. 911–925, May 2019, doi: [10.1007/s11277-019-06195-3](https://doi.org/10.1007/s11277-019-06195-3).
- [109] I. Hwang, B. Song, and S. S. Soliman, "A holistic view on hyper-dense heterogeneous and small cell networks," *IEEE Commun. Mag.*, vol. 51, no. 6, pp. 20–27, Jun. 2013, doi: [10.1109/MCOM.2013.6525591](https://doi.org/10.1109/MCOM.2013.6525591).
- [110] F. Tang, Z. M. Fadlullah, N. Kato, F. Ono, and R. Miura, "AC-POCA: Anticoordination game based partially overlapping channels assignment in combined UAV and D2D-based networks," *IEEE Trans. Veh. Technol.*, vol. 67, no. 2, pp. 1672–1683, Feb. 2018, doi: [10.1109/TVT.2017.2753280](https://doi.org/10.1109/TVT.2017.2753280).
- [111] B. Shang, L. Liu, J. Ma, and P. Fan, "Unmanned aerial vehicle meets vehicle-to-everything in secure communications," *IEEE Commun. Mag.*, vol. 57, no. 10, pp. 98–103, Oct. 2019, doi: [10.1109/MCOM.001.1900170](https://doi.org/10.1109/MCOM.001.1900170).
- [112] A. I. Hentati and L. C. Fourati, "Comprehensive survey of UAVs communication networks," *Comput. Standards Inter.*, vol. 72, Oct. 2020, Art. no. 103451, doi: [10.1016/j.csi.2020.103451](https://doi.org/10.1016/j.csi.2020.103451).
- [113] A. Trivedi and P. Pawar, "D2D in UAV networks," in *Wiley 5G RefEssent. 5G Ref. Online*, 2019, pp. 1–17.
- [114] B. Shang, L. Liu, R. M. Rao, V. Marojevic, and J. H. Reed, "3D spectrum sharing for hybrid D2D and UAV networks," *IEEE Trans. Commun.*, vol. 68, no. 9, pp. 5375–5389, Sep. 2020, doi: [10.1109/TCOMM.2020.2997957](https://doi.org/10.1109/TCOMM.2020.2997957).
- [115] A. Omri, M. O. Hasna, M. Z. Shakir, and M. Shaqfeh, "Mode selection schemes for D2D enabled unmanned aerial vehicle-based wireless networks," *IET Commun.*, vol. 13, no. 10, pp. 1397–1404, Jun. 2019, doi: [10.1049/iet-com.2018.5834](https://doi.org/10.1049/iet-com.2018.5834).
- [116] J. Ji, K. Zhu, D. Niyato, and R. Wang, "Probabilistic cache placement in UAV-assisted networks with D2D connections: Performance analysis and trajectory optimization," *IEEE Trans. Commun.*, vol. 68, no. 10, pp. 6331–6345, Oct. 2020, doi: [10.1109/TCOMM.2020.3006908](https://doi.org/10.1109/TCOMM.2020.3006908).
- [117] I. Budhiraja, N. Kumar, and S. Tyagi, "Deep-reinforcement-learning-based proportional fair scheduling control scheme for underlay D2D communication," *IEEE Internet Things J.*, vol. 8, no. 5, pp. 3143–3156, Mar. 2021, doi: [10.1109/JIOT.2020.3014926](https://doi.org/10.1109/JIOT.2020.3014926).
- [118] A. Sultana, L. Zhao, and X. Fernando, "Efficient resource allocation in device-to-device communication using cognitive radio technology," *IEEE Trans. Veh. Technol.*, vol. 66, no. 11, pp. 10024–10034, Nov. 2017, doi: [10.1109/TVT.2017.2743058](https://doi.org/10.1109/TVT.2017.2743058).
- [119] A. Sultana, L. Zhao, and X. Fernando, "Energy-efficient power allocation in underlay and overlay cognitive device-to-device communications," *IET Commun.*, vol. 13, no. 2, pp. 162–170, Jan. 2019, doi: [10.1049/iet-com.2018.5464](https://doi.org/10.1049/iet-com.2018.5464).
- [120] M. Noura and R. Nordin, "A survey on interference management for device-to-device (D2D) communication and its challenges in 5G Networks," *J. Netw. Comput. Appl.*, vol. 71, pp. 130–150, Aug. 2016, doi: [10.1016/j.jnca.2016.04.021](https://doi.org/10.1016/j.jnca.2016.04.021).
- [121] X. Zhang, W. Gu, H. Zhang, and M. Wang, "Hybrid communication path orchestration for 5G heterogeneous ultra-dense networks," *IEEE Netw.*, vol. 33, no. 4, pp. 112–118, Jul. 2019, doi: [10.1109/MNET.2019.1800402](https://doi.org/10.1109/MNET.2019.1800402).
- [122] K. Xu, Y. Qu, and K. Yang, "A tutorial on the Internet of Things: From a heterogeneous network integration perspective," *IEEE Netw.*, vol. 30, no. 2, pp. 102–108, Mar. 2016, doi: [10.1109/MNET.2016.7437031](https://doi.org/10.1109/MNET.2016.7437031).
- [123] Y. Xu, G. Gui, H. Gacanin, and F. Adachi, "A survey on resource allocation for 5G heterogeneous networks: Current research, future trends, and challenges," *IEEE Commun. Surveys Tuts.*, vol. 23, no. 2, pp. 668–695, 2nd Quart., 2021, doi: [10.1109/COMST.2021.3059896](https://doi.org/10.1109/COMST.2021.3059896).
- [124] I. Ioannou, C. Christophorou, V. Vassiliou, and A. Pitsillides, "Performance evaluation of transmission mode selection in D2D communication," in *Proc. 11th IFIP Int. Conf. New Technol., Mobility Secur. (NTMS)*, Apr. 2021, pp. 1–7, doi: [10.1109/NTMS49979.2021.9432648](https://doi.org/10.1109/NTMS49979.2021.9432648).
- [125] G. Hou and L. Chen, "D2D communication mode selection and resource allocation in 5G wireless networks," *Comput. Commun.*, vol. 155, pp. 244–251, Apr. 2020, doi: [10.1016/j.comcom.2020.03.025](https://doi.org/10.1016/j.comcom.2020.03.025).
- [126] M. Wang and Z. Yan, "A survey on security in D2D communications," *Mobile Netw. Appl.*, vol. 22, no. 2, pp. 195–208, Apr. 2017, doi: [10.1007/s11036-016-0741-5](https://doi.org/10.1007/s11036-016-0741-5).
- [127] J. Cao, M. Ma, H. Li, R. Ma, Y. Sun, P. Yu, and L. Xiong, "A survey on security aspects for 3GPP 5G networks," *IEEE Commun. Surveys Tuts.*, vol. 22, no. 1, pp. 170–195, 1st Quart., 2020, doi: [10.1109/COMST.2019.2951818](https://doi.org/10.1109/COMST.2019.2951818).
- [128] O. Hayat, R. Ngah, Z. Kaleem, S. Z. M. Hashim, and J. J. Rodrigues, "A survey on security and privacy challenges in device discovery for next-generation systems," *IEEE Access*, vol. 8, pp. 84584–84603, 2020, doi: [10.1109/ACCESS.2020.2991459](https://doi.org/10.1109/ACCESS.2020.2991459).
- [129] M. Shih, "Mobility management in D2D," in *Wiley 5G Ref.*, vol. 1. Hoboken, NJ, USA: Wiley, 2019, pp. 1–22.
- [130] T. D. Hoang, L. B. Le, and T. Le-Ngoc, "Joint mode selection and resource allocation for relay-based D2D communications," *IEEE Commun. Lett.*, vol. 21, no. 2, pp. 398–401, Feb. 2017, doi: [10.1109/LCOMM.2016.2617863](https://doi.org/10.1109/LCOMM.2016.2617863).

- [131] L. Wang, H. Tang, H. Wu, and G. Stüber, "Resource allocation for D2D communications underlay in Rayleigh fading channels," *IEEE Trans. Veh. Technol.*, vol. 66, no. 2, pp. 1159–1170, Feb. 2017, doi: [10.1109/TVT.2016.2553124](https://doi.org/10.1109/TVT.2016.2553124).
- [132] A. F. Ashtiani and S. Pierre, "Power allocation and resource assignment for secure D2D communication underlying cellular networks: A Tabu search approach," *Comput. Netw.*, vol. 178, Sep. 2020, Art. no. 107350, doi: [10.1016/j.comnet.2020.107350](https://doi.org/10.1016/j.comnet.2020.107350).
- [133] A. Sultana, I. Woungang, A. Anpalagan, L. Zhao, and L. Ferdouse, "Efficient resource allocation in SCMA-enabled device-to-device communication for 5G networks," *IEEE Trans. Veh. Technol.*, vol. 69, no. 5, pp. 5343–5354, May 2020, doi: [10.1109/TVT.2020.2983569](https://doi.org/10.1109/TVT.2020.2983569).
- [134] M. K. Pedhadiya, R. K. Jha, and H. G. Bhatt, "Device to device communication: A survey," *J. Netw. Comput. Appl.*, vol. 129, pp. 71–89, Nov. 2019, doi: [10.1016/j.jnca.2018.10.012](https://doi.org/10.1016/j.jnca.2018.10.012).
- [135] R. Zhang, C. Qi, Y. Li, Y. Ruan, C.-X. Wang, and H. Zhang, "Towards energy-efficient underlaid device-to-device communications: A joint resource management approach," *IEEE Access*, vol. 7, pp. 31385–31396, 2019, doi: [10.1109/ACCESS.2019.2903214](https://doi.org/10.1109/ACCESS.2019.2903214).
- [136] J. Wang, Y. Huang, S. Jin, R. Schober, X. You, and C. Zhao, "Resource management for device-to-device communication: A physical layer security perspective," *IEEE J. Sel. Areas Commun.*, vol. 36, no. 4, pp. 946–960, Apr. 2018, doi: [10.1109/JSAC.2018.2825484](https://doi.org/10.1109/JSAC.2018.2825484).
- [137] X. Li, R. Shankaran, M. A. Orgun, G. Fang, and Y. Xu, "Resource allocation for underlay D2D communication with proportional fairness," *IEEE Trans. Veh. Technol.*, vol. 67, no. 7, pp. 6244–6258, Jul. 2018, doi: [10.1109/TVT.2018.2817613](https://doi.org/10.1109/TVT.2018.2817613).
- [138] S. Alemaishat, O. A. Saraereh, I. Khan, and B. J. Choi, "An efficient resource allocation algorithm for D2D communications based on NOMA," *IEEE Access*, vol. 7, pp. 120238–120247, 2019, doi: [10.1109/ACCESS.2019.2937401](https://doi.org/10.1109/ACCESS.2019.2937401).
- [139] W.-K. Lai, Y.-C. Wang, H.-C. Lin, and J.-W. Li, "Efficient resource allocation and power control for LTE-A D2D communication with pure D2D model," *IEEE Trans. Veh. Technol.*, vol. 69, no. 3, pp. 3202–3216, Mar. 2020, doi: [10.1109/TVT.2020.2964286](https://doi.org/10.1109/TVT.2020.2964286).
- [140] L. Wang, C. Li, Y. Zhang, and G. Gui, "Game-theoretic social-aware resource allocation for device-to-device communications underlying cellular network," *Wireless Commun. Mobile Comput.*, vol. 2018, pp. 1–12, 2018, doi: [10.1155/2018/5084842](https://doi.org/10.1155/2018/5084842).
- [141] J. Huang, Y. Yin, Y. Zhao, Q. Duan, W. Wang, and S. Yu, "A game-theoretic resource allocation approach for intercell device-to-device communications in cellular networks," *IEEE Trans. Emerg. Topics Comput.*, vol. 4, no. 4, pp. 475–486, Oct./Dec. 2016, doi: [10.1109/TETC.2014.2384372](https://doi.org/10.1109/TETC.2014.2384372).
- [142] P. Mach, Z. Becvar, and M. Najla, "Resource allocation for D2D communication with multiple D2D pairs reusing multiple channels," *IEEE Wireless Commun. Lett.*, vol. 8, no. 4, pp. 1008–1011, Aug. 2019, doi: [10.1109/LWC.2019.2903798](https://doi.org/10.1109/LWC.2019.2903798).
- [143] B.-Y. Huang, S.-T. Su, C.-Y. Wang, C.-W. Yeh, and H.-Y. Wei, "Resource allocation in D2D communication-A game theoretic approach," in *Proc. IEEE Int. Conf. Commun. Workshops (ICC)*, Jun. 2014, pp. 483–488, doi: [10.1109/ICCW.2014.6881245](https://doi.org/10.1109/ICCW.2014.6881245).
- [144] K. Modak and S. Rahman, "Multi-cell interference management in in-band D2D communication under LTE-A network," in *Proc. Int. Conf. Comput., Electron. Commun. Eng. (iCCECE)*, Aug. 2021, pp. 13–18, doi: [10.1109/iCCECE52344.2021.9534849](https://doi.org/10.1109/iCCECE52344.2021.9534849).
- [145] S. Shalmashi, G. Miao, and S. Ben Slimane, "Interference management for multiple device-to-device communications underlying cellular networks," in *Proc. IEEE 24th Annu. Int. Symp. Pers., Indoor, Mobile Radio Commun. (PIMRC)*, Sep. 2013, pp. 223–227, doi: [10.1109/PIMRC.2013.6666135](https://doi.org/10.1109/PIMRC.2013.6666135).
- [146] S. Ravindra and G. K. Siddesh, "Interference mitigation and mobility management for D2D communication in LTE-A networks," *Int. J. Wireless Microw. Technol.*, vol. 9, no. 2, pp. 20–31, Mar. 2019, doi: [10.5815/ijwmt.2019.02.03](https://doi.org/10.5815/ijwmt.2019.02.03).
- [147] D. D. Ningombam, C. G. Lee, and S. Shin, "Interference mitigation for multicast D2D communications underlay cellular networks," in *Proc. Int. Conf. Artif. Intell. Inf. Commun. (ICAIIIC)*, Feb. 2019, pp. 1–4, doi: [10.1109/ICAIIIC.2019.8668982](https://doi.org/10.1109/ICAIIIC.2019.8668982).
- [148] N. A. Ali, M. El-Soudani, H. M. ElSayed, H.-A.-M. Mourad, and H. H. Amer, "Interference mitigation in D2D communications for 5G mobile networks," in *Proc. 13th Int. Conf. Electron., Comput. Artif. Intell. (ECAI)*, Jul. 2021, pp. 1–6, doi: [10.1109/ECAI52376.2021.9515123](https://doi.org/10.1109/ECAI52376.2021.9515123).
- [149] R. Zeeshan Ahamad, A. Rehman Javed, S. Mehmood, M. Zubair Khan, A. Noorwali, and M. Rizwan, "Interference mitigation in D2D communication underlying cellular networks: Towards green energy," *Comput., Mater. Continua*, vol. 68, no. 1, pp. 45–58, 2021, doi: [10.32604/cmc.2021.016082](https://doi.org/10.32604/cmc.2021.016082).
- [150] S. Najeh and A. Bouallegue, "Distributed vs centralized game theory-based mode selection and power control for D2D communications," *Phys. Commun.*, vol. 38, Feb. 2020, Art. no. 100962, doi: [10.1016/j.phycom.2019.100962](https://doi.org/10.1016/j.phycom.2019.100962).
- [151] X. Liu, H. Xiao, and A. T. Chronopoulos, "Joint mode selection and power control for interference management in D2D-enabled heterogeneous cellular networks," *IEEE Trans. Veh. Technol.*, vol. 69, no. 9, pp. 9707–9719, Sep. 2020, doi: [10.1109/TVT.2020.3001874](https://doi.org/10.1109/TVT.2020.3001874).
- [152] M. Kamruzzaman, N. I. Sarkar, and J. Gutierrez, "A dynamic algorithm for interference management in D2D-enabled heterogeneous cellular networks: Modeling and analysis," *Sensors*, vol. 22, no. 3, p. 1063, Jan. 2022, doi: [10.3390/s22031063](https://doi.org/10.3390/s22031063).
- [153] O. N. C. Yilmaz, Z. Li, K. Valkealahti, M. A. Uusitalo, M. Moisio, P. Lunden, and C. Wijting, "Smart mobility management for D2D communications in 5G networks," in *Proc. IEEE Wireless Commun. Netw. Conf. Workshops (WCNCW)*, Apr. 2014, pp. 219–223, doi: [10.1109/WCNCW.2014.6934889](https://doi.org/10.1109/WCNCW.2014.6934889).
- [154] K. Ouali, M. Kassar, T. M. Trang Nguyen, K. Sethom, and B. Kervella, "An efficient D2D handover management scheme for SDN-based 5G networks," in *Proc. IEEE 17th Annu. Consum. Commun. Netw. Conf. (CCNC)*, Jan. 2020, pp. 1–6, doi: [10.1109/CCNC46108.2020.9045534](https://doi.org/10.1109/CCNC46108.2020.9045534).
- [155] K. Ouali, M. Kassar, and K. Sethom, "Handover performance analysis for managing D2D mobility in 5G cellular networks," *IET Commun.*, vol. 12, no. 15, pp. 1925–1936, Sep. 2018, doi: [10.1049/iet-com.2018.5561](https://doi.org/10.1049/iet-com.2018.5561).
- [156] A. N. Kasim, I. Shayea, S. A. Khan, A. Alhammedi, and M. Ergen, "Evolutionary paths towards mobility management in 5G heterogeneous networks," in *Proc. IEEE Microw. Theory Techn. Wireless Commun. (MTTW)*, Oct. 2020, pp. 24–29, doi: [10.1109/MTTW51045.2020.9245046](https://doi.org/10.1109/MTTW51045.2020.9245046).
- [157] M. Wang and Z. Yan, "Security in D2D communications: A review," in *Proc. IEEE Trustcom/BigDataSE/ISPA*, vol. 1, Aug. 2015, pp. 1199–1204, doi: [10.1109/Trustcom.2015.505](https://doi.org/10.1109/Trustcom.2015.505).
- [158] K. Liu, W. Shen, Y. Cheng, L. X. Cai, Q. Li, S. Zhou, and Z. Niu, "Security analysis of mobile device-to-device network applications," *IEEE Internet Things J.*, vol. 6, no. 2, pp. 2922–2932, Apr. 2019, doi: [10.1109/JIOT.2018.2877174](https://doi.org/10.1109/JIOT.2018.2877174).
- [159] A. Zhang, J. Chen, R. Q. Hu, and Y. Qian, "SeDS: Secure data sharing strategy for D2D communication in LTE-advanced networks," *IEEE Trans. Veh. Technol.*, vol. 65, no. 4, pp. 2659–2672, Apr. 2016, doi: [10.1109/TVT.2015.2416002](https://doi.org/10.1109/TVT.2015.2416002).
- [160] S. S. Salwe and K. K. Naik, "Heterogeneous wireless network for IoT applications," *IETE Tech. Rev.*, vol. 36, no. 1, pp. 61–68, Jan. 2019, doi: [10.1080/02564602.2017.1400412](https://doi.org/10.1080/02564602.2017.1400412).
- [161] Z. Kuang, G. Li, L. Zhang, H. Zhou, C. Li, and A. Liu, "Energy efficient mode selection, base station selection and resource allocation algorithm in D2D heterogeneous networks," *Peer-Peer Netw. Appl.*, vol. 13, no. 5, pp. 1814–1829, Sep. 2020, doi: [10.1007/s12083-020-00915-4](https://doi.org/10.1007/s12083-020-00915-4).
- [162] J. Yan, Z. Kuang, F. Yang, and X. Deng, "Mode selection and resource allocation algorithm in energy-harvesting D2D heterogeneous network," *IEEE Access*, vol. 7, pp. 179929–179941, 2019, doi: [10.1109/ACCESS.2019.2956111](https://doi.org/10.1109/ACCESS.2019.2956111).
- [163] A. A. Algedir and H. H. Refai, "Energy efficiency optimization and dynamic mode selection algorithms for D2D communication under Het-Net in downlink reuse," *IEEE Access*, vol. 8, pp. 95251–95265, 2020, doi: [10.1109/ACCESS.2020.2995833](https://doi.org/10.1109/ACCESS.2020.2995833).
- [164] Y. Zhang, Y. Shen, X. Jiang, and S. Kasahara, "Mode selection and spectrum partition for D2D in-band communications: A physical layer security perspective," *IEEE Trans. Commun.*, vol. 67, no. 1, pp. 623–638, Jan. 2019, doi: [10.1109/TCOMM.2018.2865930](https://doi.org/10.1109/TCOMM.2018.2865930).
- [165] C.-Y. Chen, C.-A. Sung, and H.-H. Chen, "Capacity maximization based on optimal mode selection in multi-mode and multi-pair D2D communications," *IEEE Trans. Veh. Technol.*, vol. 68, no. 7, pp. 6524–6534, Jul. 2019, doi: [10.1109/TVT.2019.2913987](https://doi.org/10.1109/TVT.2019.2913987).
- [166] S. W. H. Shah, M. M. U. Rahman, A. N. Mian, A. Imran, S. Mumtaz, and O. A. Dobre, "On the impact of mode selection on effective capacity of device-to-device communication," *IEEE Wireless Commun. Lett.*, vol. 8, no. 3, pp. 945–948, Jun. 2019, doi: [10.1109/LWC.2019.2901460](https://doi.org/10.1109/LWC.2019.2901460).

- [167] J. Yue, C. Ma, H. Yu, Z. Yang, and X. Gan, "Secrecy-based channel assignment for device-to-device communication: An auction approach," in *Proc. Int. Conf. Wireless Commun. Signal Process.*, Oct. 2013, pp. 1–6, doi: [10.1109/WCSP.2013.6677244](https://doi.org/10.1109/WCSP.2013.6677244).
- [168] H. Long, W. Xiange, X. Zhang, J. Wang, and W. Wang, "Cooperative jamming and power allocation in three-phase two-way relaying system with untrusted relay node," in *Proc. XXXIth URSI Gen. Assem. Sci. Symp. (URSI GASS)*, Aug. 2014, pp. 1–4, doi: [10.1109/URSIGASS.2014.6929316](https://doi.org/10.1109/URSIGASS.2014.6929316).
- [169] Z. Li, H. Hu, H. Hu, B. Huang, J. Ge, and V. Chang, "Security and energy-aware collaborative task offloading in D2D communication," *Future Gener. Comput. Syst.*, vol. 118, pp. 358–373, May 2021, doi: [10.1016/j.future.2021.01.021](https://doi.org/10.1016/j.future.2021.01.021).
- [170] M. Mehrabi, S. Shen, Y. Hai, V. Latzko, G. Koudouridis, X. Gelabert, M. Reisslein, and F. Fitzek, "Mobility- and energy-aware cooperative edge offloading for dependent computation tasks," *Network*, vol. 1, no. 2, pp. 191–214, Sep. 2021, doi: [10.3390/network1020012](https://doi.org/10.3390/network1020012).
- [171] C. Suraci, S. Pizzi, D. Garompolo, G. Araniti, A. Molinaro, and A. Iera, "Trusted and secured D2D-aided communications in 5G networks," *Ad Hoc Netw.*, vol. 114, Apr. 2021, Art. no. 102403, doi: [10.1016/j.adhoc.2020.102403](https://doi.org/10.1016/j.adhoc.2020.102403).
- [172] J. Suomalainen, J. Julku, M. Vehkaperä, and H. Posti, "Securing public safety communications on commercial and tactical 5G networks: A survey and future research directions," *IEEE Open J. Commun. Soc.*, vol. 2, pp. 1590–1615, 2021, doi: [10.1109/ojcoms.2021.3093529](https://doi.org/10.1109/ojcoms.2021.3093529).
- [173] C. Jarray and A. Giovanidis, "The effects of mobility on the hit performance of cached D2D networks," in *Proc. 14th Int. Symp. Modeling Optim. Mobile, Ad Hoc, Wireless Netw. (WiOpt)*, May 2016, pp. 1–8, doi: [10.1109/WIOPT.2016.7492958](https://doi.org/10.1109/WIOPT.2016.7492958).
- [174] R. Wang, J. Zhang, S. H. Song, and K. B. Letaief, "Mobility-aware caching in D2D networks," *IEEE Trans. Wireless Commun.*, vol. 16, no. 8, pp. 5001–5015, Aug. 2017, doi: [10.1109/TWC.2017.2705038](https://doi.org/10.1109/TWC.2017.2705038).
- [175] S. Nayak and R. Patgiri, "6G communication: Envisioning the key issues and challenges," *EAI Endorsed Trans. Internet Things*, vol. 6, no. 24, Feb. 2021, Art. no. 166959, doi: [10.4108/eai.11-11-2020.166959](https://doi.org/10.4108/eai.11-11-2020.166959).
- [176] S. Chen, Y. Liang, S. Sun, S. Kang, W. Cheng, and M. Peng, "Vision, requirements, and technology trend of 6G: How to tackle the challenges of system coverage, capacity, user data-rate and movement speed," *IEEE Wireless Commun.*, vol. 27, no. 2, pp. 218–228, Apr. 2020, doi: [10.1109/MWC.001.1900333](https://doi.org/10.1109/MWC.001.1900333).
- [177] Z. Zhang, Y. Xiao, Z. Ma, M. Xiao, Z. Ding, X. Lei, G. K. Karagiannidis, and P. Fan, "6G wireless networks: Vision, requirements, architecture, and key technologies," *IEEE Veh. Technol. Mag.*, vol. 14, no. 3, pp. 28–41, Sep. 2019, doi: [10.1109/MVT.2019.2921208](https://doi.org/10.1109/MVT.2019.2921208).
- [178] N. Kato, B. Mao, F. Tang, Y. Kawamoto, and J. Liu, "Ten challenges in advancing machine learning technologies toward 6G," *IEEE Wireless Commun.*, vol. 27, no. 3, pp. 96–103, Jun. 2020, doi: [10.1109/MWC.001.1900476](https://doi.org/10.1109/MWC.001.1900476).
- [179] J. Zhu, M. Zhao, S. Zhang, and W. Zhou, "Exploring the road to 6G: ABC—Foundation for intelligent mobile networks," *China Commun.*, vol. 17, no. 6, pp. 51–67, Jun. 2020, doi: [10.23919/JCC.2020.06.005](https://doi.org/10.23919/JCC.2020.06.005).
- [180] H. Viswanathan and P. E. Mogensen, "Communications in the 6G era," *IEEE Access*, vol. 8, pp. 57063–57074, 2020, doi: [10.1109/ACCESS.2020.2981745](https://doi.org/10.1109/ACCESS.2020.2981745).
- [181] Y. Lu and X. Zheng, "6G: A survey on technologies, scenarios, challenges, and the related issues," *J. Ind. Inf. Integr.*, vol. 19, Sep. 2020, Art. no. 100158, doi: [10.1016/j.jii.2020.100158](https://doi.org/10.1016/j.jii.2020.100158).
- [182] S. Zhang, J. Liu, H. Guo, M. Qi, and N. Kato, "Envisioning device-to-device communications in 6G," *IEEE Netw.*, vol. 34, no. 3, pp. 86–91, Jun. 2020, doi: [10.1109/MNET.001.1900652](https://doi.org/10.1109/MNET.001.1900652).
- [183] K. B. Letaief, W. Chen, Y. Shi, J. Zhang, and Y. A. Zhang, "The roadmap to 6G: AI empowered wireless networks," *IEEE Commun. Mag.*, vol. 57, no. 8, pp. 84–90, Aug. 2019, doi: [10.1109/MCOM.2019.1900271](https://doi.org/10.1109/MCOM.2019.1900271).
- [184] Y. Fu, K. N. Doan, and T. Q. S. Quek, "On recommendation-aware content caching for 6G: An artificial intelligence and optimization empowered paradigm," *Digit. Commun. Netw.*, vol. 6, no. 3, pp. 304–311, Aug. 2020, doi: [10.1016/j.dcan.2020.06.005](https://doi.org/10.1016/j.dcan.2020.06.005).
- [185] H. Elayan, O. Amin, R. M. Shubair, and M.-S. Alouini, "Terahertz communication: The opportunities of wireless technology beyond 5G," in *Proc. Int. Conf. Adv. Commun. Technol. Netw. (CommNet)*, Apr. 2018, pp. 1–5, doi: [10.1109/COMMNET.2018.8360286](https://doi.org/10.1109/COMMNET.2018.8360286).
- [186] Z. Chen, X. Ma, B. Zhang, Y. X. Zhang, Z. Niu, N. Kuang, W. Chen, L. Li, and S. Li, "A survey on terahertz communications," *China Commun.*, vol. 16, no. 2, pp. 1–35, Feb. 2019, doi: [10.12676/j.cc.2019.02.001](https://doi.org/10.12676/j.cc.2019.02.001).
- [187] C. Chaccour, M. N. Soorki, W. Saad, M. Bennis, and P. Popovski, "Can terahertz provide high-rate reliable low latency communications for wireless VR?" *IEEE Internet Things J.*, early access, Jan. 12, 2022, doi: [10.1109/JIOT.2022.3142674](https://doi.org/10.1109/JIOT.2022.3142674).
- [188] N. A. Tultul, S. Farha, S. S. Hossain, M. Akbar Hossain, and S. R. Sabuj, "Device-to-device communication in terahertz frequency band: Enhancement of energy efficiency," in *Proc. IEEE REGION 10 Conf. (TENCON)*, Nov. 2020, pp. 117–122, doi: [10.1109/TENCON50793.2020.9293736](https://doi.org/10.1109/TENCON50793.2020.9293736).
- [189] S. Kim and A. Zajić, "Statistical modeling and simulation of short-range device-to-device communication channels at sub-THz frequencies," *IEEE Trans. Wireless Commun.*, vol. 15, no. 9, pp. 6423–6433, Sep. 2016, doi: [10.1109/TWC.2016.2585103](https://doi.org/10.1109/TWC.2016.2585103).
- [190] S. Zhang, "An overview of network slicing for 5G," *IEEE Wireless Commun.*, vol. 26, no. 3, pp. 111–117, Jun. 2019, doi: [10.1109/MWC.2019.1800234](https://doi.org/10.1109/MWC.2019.1800234).
- [191] I. Ahmad, S. Namal, M. Ylianttila, and A. Gurtov, "Towards software defined cognitive networking," in *Proc. 7th Int. Conf. New Technol., Mobility Secur. (NTMS)*, Jul. 2015, pp. 1–5, doi: [10.1109/NTMS.2015.7266528](https://doi.org/10.1109/NTMS.2015.7266528).
- [192] P. Cheng, L. Deng, H. Yu, Y. Xu, and H. Wang, "Resource allocation for cognitive networks with D2D communication: An evolutionary approach," in *Proc. IEEE Wireless Commun. Netw. Conf. (WCNC)*, Apr. 2012, pp. 2671–2676, doi: [10.1109/WCNC.2012.6214252](https://doi.org/10.1109/WCNC.2012.6214252).
- [193] A. H. Sakr and E. Hossain, "Cognitive and energy harvesting-based D2D communication in cellular networks: Stochastic geometry modeling and analysis," *IEEE Trans. Commun.*, vol. 63, no. 5, pp. 1867–1880, May 2015, doi: [10.1109/TCOMM.2015.2411266](https://doi.org/10.1109/TCOMM.2015.2411266).
- [194] X. Yu, D. Xu, and R. Schober, "MISO wireless communication systems via intelligent reflecting surfaces: (Invited Paper)," in *Proc. IEEE/CIC Int. Conf. Commun. China (ICCC)*, Aug. 2019, pp. 735–740, doi: [10.1109/ICCCChina.2019.8855810](https://doi.org/10.1109/ICCCChina.2019.8855810).
- [195] O. Özdogan, E. Björnson, and E. G. Larsson, "Intelligent reflecting surfaces: Physics, propagation, and pathloss modeling," *IEEE Wireless Commun. Lett.*, vol. 9, no. 5, pp. 581–585, May 2020, doi: [10.1109/LWC.2019.2960779](https://doi.org/10.1109/LWC.2019.2960779).
- [196] S. Gong, X. Lu, D. T. Hoang, and D. Niyato, "Toward smart wireless communications via intelligent reflecting surfaces: A contemporary survey," *IEEE Commun. Surveys Tuts.*, vol. 22, no. 4, pp. 2283–2314, 4th Quart., 2020, doi: [10.1109/COMST.2020.3004197](https://doi.org/10.1109/COMST.2020.3004197).
- [197] J. Zhao, "A survey of intelligent reflecting surfaces (IRSs): Towards 6G wireless communication networks," 2019, *arXiv:1907.04789*.
- [198] C. Zhang, W. Chen, Q. Chen, and C. He, "Distributed intelligent reflecting surfaces-aided device-to-device communications system," *J. Commun. Inf. Netw.*, vol. 6, no. 3, pp. 197–207, Sep. 2021, doi: [10.23919/JCIN.2021.9549117](https://doi.org/10.23919/JCIN.2021.9549117).
- [199] C. Cai, H. Yang, X. Yuan, and Y.-C. Liang, "Two-timescale optimization for intelligent reflecting surface aided D2D underlay communication," in *Proc. IEEE Global Commun. Conf. (GLOBECOM)*, Dec. 2020, pp. 1–6, doi: [10.1109/GLOBECOM42002.2020.9322204](https://doi.org/10.1109/GLOBECOM42002.2020.9322204).
- [200] A. Shawish and M. Salama, "Cloud computing: Paradigms and technologies," in *Studies in Computational Intelligence*, vol. 495, F. Xhafa and N. Bessis, Eds. Berlin, Germany: Springer, 2014, pp. 39–67.
- [201] E. Ahmed and M. H. Rehmani, "Mobile edge computing: Opportunities, solutions, and challenges," *Future Generat. Comput. Syst.*, vol. 70, pp. 59–63, May 2017, doi: [10.1016/j.future.2016.09.015](https://doi.org/10.1016/j.future.2016.09.015).
- [202] N. Abbas, Y. Zhang, A. Taherkordi, and T. Skeie, "Mobile edge computing: A survey," *IEEE Internet Things J.*, vol. 5, no. 1, pp. 450–465, Feb. 2018, doi: [10.1109/JIOT.2017.2750180](https://doi.org/10.1109/JIOT.2017.2750180).
- [203] Y. Kai, J. Wang, and H. Zhu, "Energy minimization for D2D-assisted mobile edge computing networks," in *Proc. IEEE Int. Conf. Commun. (ICC)*, May 2019, pp. 1–6, doi: [10.1109/ICC.2019.8761816](https://doi.org/10.1109/ICC.2019.8761816).
- [204] X. Chen, L. Pu, L. Gao, W. Wu, and D. Wu, "Exploiting massive D2D collaboration for energy-efficient mobile edge computing," *IEEE Wireless Commun.*, vol. 24, no. 4, pp. 64–71, Aug. 2017.
- [205] U. Saleem, Y. Liu, S. Jangsher, X. Tao, and Y. Li, "Latency minimization for D2D-enabled partial computation offloading in mobile edge computing," *IEEE Trans. Veh. Technol.*, vol. 69, no. 4, pp. 4472–4486, Apr. 2020, doi: [10.1109/TVT.2020.2978027](https://doi.org/10.1109/TVT.2020.2978027).
- [206] S. Zhang, H. Zhang, and L. Song, "Beyond D2D: Full dimension UAV-to-everything communications in 6G," *IEEE Trans. Veh. Technol.*, vol. 69, no. 6, pp. 6592–6602, Apr. 2020, doi: [10.1109/TVT.2020.2984624](https://doi.org/10.1109/TVT.2020.2984624).
- [207] F. Burkhardt, *6G White Paper on Validation and Trials for Verticals Towards 2030's*. 2020.

- [208] N. Islam, M. M. Rashid, F. Pasandideh, B. Ray, S. Moore, and R. Kadel, "A review of applications and communication technologies for Internet of Things (IoT) and unmanned aerial vehicle (UAV) based sustainable smart farming," *Sustainability*, vol. 13, no. 4, p. 1821, Feb. 2021, doi: [10.3390/su13041821](https://doi.org/10.3390/su13041821).
- [209] J. Zeb, A. Hassan, and M. D. Nisar, "Joint power and spectrum allocation for D2D communication overlaying cellular networks," *Comput. Netw.*, vol. 184, Jan. 2021, Art. no. 107683, doi: [10.1016/j.comnet.2020.107683](https://doi.org/10.1016/j.comnet.2020.107683).
- [210] S. Alwan, I. Fajjari, N. Aitsaadi, and M. Kaddour, "5G: Optimization of multicast routing and wireless resource allocation in D2D communications," in *Proc. IEEE Int. Conf. Commun. (ICC)*, Jun. 2021, pp. 1–6, doi: [10.1109/ICC42927.2021.9500416](https://doi.org/10.1109/ICC42927.2021.9500416).
- [211] H.-B. Jeon, B.-H. Koo, S.-H. Park, J. Park, and C.-B. Chae, "Graph-theory-based resource allocation and mode selection in D2D communication systems: The role of full-duplex," *IEEE Wireless Commun. Lett.*, vol. 10, no. 2, pp. 236–240, Feb. 2021, doi: [10.1109/LWC.2020.3025312](https://doi.org/10.1109/LWC.2020.3025312).
- [212] H. Zhang, L. Song, and Z. Han, "Radio resource allocation for device-to-device underlay communication using hypergraph theory," *IEEE Trans. Wireless Commun.*, vol. 15, no. 7, pp. 4852–4861, Jul. 2016, doi: [10.1109/TWC.2016.2547862](https://doi.org/10.1109/TWC.2016.2547862).
- [213] M. Subramani and V. B. Kumaravelu, "A quality-aware fuzzy-logic-based vertical handover decision algorithm for device-to-device communication," *Arabian J. Sci. Eng.*, vol. 44, no. 3, pp. 2413–2425, Mar. 2019, doi: [10.1007/s13369-018-3560-0](https://doi.org/10.1007/s13369-018-3560-0).
- [214] M. Zhang, Y. Dou, P. H. J. Chong, H. C. B. Chan, and B.-C. Seet, "Fuzzy logic-based resource allocation algorithm for V2X communications in 5G cellular networks," *IEEE J. Sel. Areas Commun.*, vol. 39, no. 8, pp. 2501–2513, Aug. 2021, doi: [10.1109/JSAC.2021.3087244](https://doi.org/10.1109/JSAC.2021.3087244).
- [215] J. Huang, C.-C. Xing, Y. Qian, and Z. J. Haas, "Resource allocation for multicell device-to-device communications underlying 5G networks: A game-theoretic mechanism with incomplete information," *IEEE Trans. Veh. Technol.*, vol. 67, no. 3, pp. 2557–2570, Mar. 2018, doi: [10.1109/TVT.2017.2765208](https://doi.org/10.1109/TVT.2017.2765208).
- [216] R. Rathi and N. Gupta, "Game theoretic and non-game theoretic resource allocation approaches for D2D communication," *Ain Shams Eng. J.*, vol. 12, no. 2, pp. 2385–2393, Jun. 2021, doi: [10.1016/j.asej.2020.09.029](https://doi.org/10.1016/j.asej.2020.09.029).
- [217] T.-H. Tan, B.-A. Chen, and Y.-F. Huang, "Performance of resource allocation in device-to-device communication systems based on evolutionarily optimization algorithms," *Appl. Sci.*, vol. 8, no. 8, p. 1271, Jul. 2018, doi: [10.3390/app8081271](https://doi.org/10.3390/app8081271).
- [218] C. Wei, T. Zhang, J. Wang, L. Wang, J. Cui, and B. Zheng, "Secure energy efficiency resource allocation for D2D communication with full-duplex radio," in *Proc. 13th Int. Conf. Wireless Commun. Signal Process. (WCSP)*, Oct. 2021, pp. 1–6, doi: [10.1109/WCSP52459.2021.9613163](https://doi.org/10.1109/WCSP52459.2021.9613163).
- [219] A. Khazali, S. Sobhi-Givi, H. Kalbkhani, and M. G. Shayesteh, "Energy-spectral efficient resource allocation and power control in heterogeneous networks with D2D communication," *Wireless Netw.*, vol. 26, no. 1, pp. 253–267, Jan. 2020, doi: [10.1007/s11276-018-1811-3](https://doi.org/10.1007/s11276-018-1811-3).
- [220] W. Lu, W. Lin, L. Yang, and S. Chen, "A heuristic D2D communication mode selection algorithm," in *Proc. Int. Conf. Cyber-Enabled Distrib. Comput. Knowl. Discovery (CyberC)*, Oct. 2017, pp. 450–453, doi: [10.1109/CyberC.2017.28](https://doi.org/10.1109/CyberC.2017.28).
- [221] Y. Luo, P. Hong, R. Su, and K. Xue, "Resource allocation for energy harvesting-powered D2D communication underlying cellular networks," *IEEE Trans. Veh. Technol.*, vol. 66, no. 11, pp. 10486–10498, Nov. 2017, doi: [10.1109/TVT.2017.2727144](https://doi.org/10.1109/TVT.2017.2727144).
- [222] O. A. Amodu, M. Othman, N. K. Noordin, and I. Ahmad, "Transmission capacity analysis of relay-assisted D2D cellular networks with interference cancellation," *Ad Hoc Netw.*, vol. 117, Jun. 2021, Art. no. 102400, doi: [10.1016/j.adhoc.2020.102400](https://doi.org/10.1016/j.adhoc.2020.102400).
- [223] R. A. Martins, I. Sousa, M. P. Queluz, and A. Rodrigues, "Interference cancellation techniques for device-to-device discovery in out-of-coverage networks," *IEEE Access*, vol. 9, pp. 10291–10303, 2021, doi: [10.1109/ACCESS.2021.3050256](https://doi.org/10.1109/ACCESS.2021.3050256).
- [224] S. Dhilipkumar and C. Arunachalaperumal, "Performance evaluation of interference mitigation scheme with D2D users in wireless networks," *Wireless Pers. Commun.*, vol. 119, no. 4, pp. 3399–3412, Aug. 2021, doi: [10.1007/s11277-021-08413-3](https://doi.org/10.1007/s11277-021-08413-3).
- [225] N. Gupta, A. D. Singh, P. Shrivastava, and V. A. Bohara, "A two-way cooperative D2D communication framework for a heterogeneous cellular network," *Wireless Pers. Commun.*, vol. 109, no. 1, pp. 579–593, Nov. 2019, doi: [10.1007/s11277-019-06580-y](https://doi.org/10.1007/s11277-019-06580-y).
- [226] J. An, K. Yang, J. Wu, N. Ye, S. Guo, and Z. Liao, "Achieving sustainable ultra-dense heterogeneous networks for 5G," *IEEE Commun. Mag.*, vol. 55, no. 12, pp. 84–90, Dec. 2017, doi: [10.1109/MCOM.2017.1700410](https://doi.org/10.1109/MCOM.2017.1700410).
- [227] P. Kumar, N. Chauhan, M. Kumar, and L. K. Awasthi, "Clustering based opportunistic traffic offloading technique for device-to-device communication," *Int. J. Syst. Assurance Eng. Manage.*, to be published, doi: [10.1007/s13198-021-01136-5](https://doi.org/10.1007/s13198-021-01136-5).
- [228] F. S. Shaikh and R. Wismüller, "Routing in multi-hop cellular device-to-device (D2D) networks: A survey," *IEEE Commun. Surveys Tuts.*, vol. 20, no. 4, pp. 2622–2657, 4th Quart., 2018, doi: [10.1109/COMST.2018.2848108](https://doi.org/10.1109/COMST.2018.2848108).
- [229] S. Basak and T. Acharya, "On energy efficient secure routing in multi-hop underlay D2D communications for IoT applications," *Ad Hoc Netw.*, vol. 108, Nov. 2020, Art. no. 102275, doi: [10.1016/j.adhoc.2020.102275](https://doi.org/10.1016/j.adhoc.2020.102275).
- [230] I. Ioannou, V. Vassiliou, C. Christophorou, and A. Pitsillides, "Distributed artificial intelligence solution for D2D communication in 5G networks," *IEEE Syst. J.*, vol. 14, no. 3, pp. 4232–4241, Sep. 2020, doi: [10.1109/JSYST.2020.2979044](https://doi.org/10.1109/JSYST.2020.2979044).
- [231] D. D. Penda, R. Wichman, T. Charalambous, G. Fodor, and M. Johansson, "A distributed mode selection scheme for full-duplex device-to-device communication," *IEEE Trans. Veh. Technol.*, vol. 68, no. 10, pp. 10267–10271, Oct. 2019, doi: [10.1109/TVT.2019.2932046](https://doi.org/10.1109/TVT.2019.2932046).
- [232] N. Alam and S. Mehruz, "Semi-distributed resource allocation and power quantization control algorithm for device-to-device network," *Int. J. Commun. Syst.*, vol. 34, no. 9, p. e4820, Jun. 2021, doi: [10.1002/dac.4820](https://doi.org/10.1002/dac.4820).
- [233] Y. Qiu, Z. Ji, Y. Zhu, G. Meng, and G. Xie, "Joint mode selection and power adaptation for D2D communication with reinforcement learning," in *Proc. 15th Int. Symp. Wireless Commun. Syst. (ISWCS)*, Aug. 2018, pp. 1–6, doi: [10.1109/ISWCS.2018.8491238](https://doi.org/10.1109/ISWCS.2018.8491238).
- [234] S. Maghsudi and D. Niyato, "On transmission mode selection in D2D-enhanced small cell networks," *IEEE Wireless Commun. Lett.*, vol. 6, no. 5, pp. 618–621, May 2017, doi: [10.1109/LWC.2017.2723558](https://doi.org/10.1109/LWC.2017.2723558).
- [235] S. Singh, D. Kedia, N. Rastogi, T. Velmurugan, and P. Prakasam, "P2P mobility management for seamless handover using D2D communication in B5G wireless technology," *Peer-Peer Netw. Appl.*, vol. 14, no. 4, pp. 1988–1997, Jul. 2021, doi: [10.1007/s12083-021-01123-4](https://doi.org/10.1007/s12083-021-01123-4).
- [236] S. Ali, M. I. Aslam, I. Ahmed, S. A. Aziz, F. Baig, M. D. Khan, and A. A. Khan, "Performance analysis of single-hop device to device communication," in *Proc. Int. Bhurban Conf. Appl. Sci. Technol. (IBCAST)*, Jan. 2021, pp. 974–978, doi: [10.1109/IBCAST51254.2021.9393266](https://doi.org/10.1109/IBCAST51254.2021.9393266).



MOHAMMED SALIH MOHAMMED GISMALLA (Senior Member, IEEE) received the B.Sc. degree (Hons.) in electronic and electrical engineering (communication) from the International University of Africa (IUA), Sudan, in 2010, the M.Sc. degree in electronic engineering (communication) from the Sudan University of Science and Technology in 2015, and the Ph.D. degree in electrical engineering (communication) from the Faculty of Electrical and Electronic Engineering, Universiti Tun Hussein Onn Malaysia (UTHM), Malaysia, in March 2021. From 2010 to 2017, he was a Teaching Assistant and a Lecturer with the Department of Communication Engineering, Faculty of Electronic and Electrical Engineering, IUA, and University of Bahri. He is currently a Post-doctoral Fellow of the Lightwave Communication Research Group, School of Electrical Engineering, Faculty of Engineering, Universiti Teknologi Malaysia (UTM). His research interests include device-to-device communication, visible light communication, optical communication, the Internet of Things, and 5G/6G networks.



ASRUL IZAM AZMI (Member, IEEE) received the B.Eng. and M.Eng. degrees in electrical engineering from Universiti Teknologi Malaysia (UTM), Johor Bahru, in 2001 and 2004, respectively, and the Ph.D. degree from the University of New South Wales (UNSW), Sydney, in 2012. He joined UTM in 2002 as a Tutor, where he is currently a Senior Lecturer. He has been appointed as the Head of Lightwave Communication Research Group, UTM, since 2014. He then joined Jurutera Budiman (M&E) Sdn Bhd Consultant firm, from September 2017 to November 2018. He went to Harbin Engineering University as a Visiting Researcher, from March 2019 to July 2019. His research interests include the development of various fiber sensing techniques and their applications.



MOHD RASHIDI BIN SALIM (Member, IEEE) was born in Johor Bahru, Johor. He received the Bachelor of Engineering (electrical-mechatronics), Master of Engineering (electrical-electronics and telecommunication), and Ph.D. (electrical engineering) degrees from Universiti Teknologi Malaysia (UTM), in 2008, 2011, and 2016, respectively. He was appointed as a Tutor with UTM, in December 2008. Currently, he is a Senior Lecturer with the School of Electrical Engineering and a Researcher in the field of optical sensors with the Lightwave Communication Research Group (LCRG), School of Electrical Engineering, Faculty of Engineering, UTM. His research interests include spectroscopic sensors, optical fiber sensors, and electromagnetics. He is a member of the Board of Engineers Malaysia (BEM).



MOHAMMAD FAIZ LIEW ABDULLAH (Senior Member, IEEE) received the B.Sc. degree (Hons.) in electrical engineering (communication), the Diploma degree in education, and the M.Eng. degree by research in optical fiber communication from the University of Technology Malaysia (UTM), in 1997, 1999, and 2000, respectively, and the Ph.D. degree in wireless optical communication engineering from The University of Warwick, U.K., in August 2007. He started his career as a Lecturer at Polytechnic Seberang Prai (PSP), in 1999, and was transferred to Universiti Tun Hussein Onn Malaysia (UTHM), in 2000 (formerly known as PLSP). At present, he is a Professor with the Department of Communication Engineering, Faculty of Electrical and Electronic Engineering, UTHM. He had 20 years' experience of teaching in higher education, which involved the subject optical fiber communication, advanced optical communication, and advanced digital signal processing. His research interests include wireless and optical communication and robotics in communication.



FARABI IQBAL received the M.Eng. degree in electronics and telecommunications from Universiti Teknologi Malaysia, and the Ph.D. degree in optical networking from the Delft University of Technology, The Netherlands. He is currently a Senior Lecturer with the School of Electrical Engineering, Universiti Teknologi Malaysia, where he has been a Faculty Member, since 2009. His research interests include network routing, resiliency, and optimization.



WAFII A. MABROUK (Graduate Student Member, IEEE) received the bachelor's degree in electrical engineering, the Master of Science degree (railway engineering), and the Ph.D. degree in electrical engineering from University Tun Hussien Onn Malaysia (UTHM), in 2013, 2015, and 2020, respectively. He joined the Department of Communications Engineering, Faculty of Electrical Engineering, UTHM, as a Research Assistant. His current research interests include optical wireless communications, intelligent transportation systems, railway systems integration, and train communication systems.



MAISARA BINTI OTHMAN (Member, IEEE) received the B.Eng. (Hons.) degree in computer system and communication engineering and the M.Sc. degree in communication network engineering from Universiti Putra Malaysia (UPM), in 2001 and 2005, respectively, and the Ph.D. degree in metro-access and short range system from DTU Fotonik, Technical University of Denmark, in 2012. Currently, she is an Associate Professor and the Deputy Dean (Student Affairs and Alumni) with the Faculty of Electrical and Electronic Engineering (FKEE), UTHM. Her research interests include advanced modulation formats, photonic wireless integration and access, and in-home network technologies.



ADEL Y. I. ASHYAP received the B.Eng., M.Eng., and Ph.D. degrees in electrical engineering from Universiti Tun Hussein Onn Malaysia (UTHM), Johor, Malaysia, in 2012, 2014, and 2019, respectively. He is currently a Postdoctoral Fellow with the Research Center of Applied Electromagnetics, Faculty of Electrical and Electronic Engineering, UTHM. He has authored and coauthored numbers of journals and proceedings. His research interests include electromagnetic bandgap (EBG), artificial magnetic conductor (AMC) for wireless body area networks (WBAN), and microstrip antennas and small antennas for biomedical devices. He received the Chancellor Award for his final year project and a number of gold, silver, and bronze medals in international and local competitions.



ABU SAHMAH MOHD SUPA'AT was born in Johor Bahru, Malaysia, in July 1963. He received the Ph.D. degree from Universiti Teknologi Malaysia (UTM), in 2004. He joined the Faculty of Electrical Engineering, UTM, in 1986, as an Assistant Lecturer. He has taught various subjects and worked on a variety of research projects in the field of optical fibers, free space optic, visible free space optic and PLC, and photonic devices. With the expertise gained in photonics switching devices, he has been working as a Visiting Researcher with the Mesa Research Institute, University of Twente, The Netherlands, ZenPhotonics Inc., South Korea, and ChemOptics Inc., South Korea, and a Visiting Professor with the Pusan National University of Korea and the City University of Hong Kong. He is presently a Professor and the Deputy Dean (Development) of the Faculty of Electrical Engineering, Universiti Teknologi Malaysia. To date, he has written more than 100 papers, which has been published in national and international journals as well as in the conferences.