

Received February 6, 2022, accepted February 16, 2022, date of publication February 18, 2022, date of current version March 4, 2022.

Digital Object Identifier 10.1109/ACCESS.2022.3152769

Wideband Three Loop Element Antenna Array for Future 5G mmwave Devices

SAAD HASSAN KIANI¹, ABDULLAH G. ALHARBI², (Member, IEEE), SHAHID KHAN³,
MOHAMED MAREY⁴, (Senior Member, IEEE), HALA MOSTAFA⁵,
AND MUHAMMAD AMIR KHAN⁶

¹Department of Electrical Engineering, IIC University of Technology, Phnom Penh 121206, Cambodia

²Department of Electrical Engineering, Faculty of Engineering, Jouf University, Sakaka 42421, Saudi Arabia

³Department of Electrical Engineering, COMSATS University Islamabad, Abbottabad 45550, Pakistan

⁴Smart Systems Engineering Laboratory, College of Engineering, Prince Sultan University, Riyadh 11586, Saudi Arabia

⁵Department of Information Technology, College of Computer and Information Sciences, Princess Nourah bint Abdulrahman University, Riyadh 11671, Saudi Arabia

⁶Department of Computer Science, COMSATS University Islamabad, Abbottabad 45550, Pakistan

Corresponding authors: Shahid Khan (shahid@cuiatd.edu.pk) and Mohamed Marey (mfmmarey@psu.edu.sa)

Princess Nourah bint Abdulrahman University Researchers Supporting Project number (PNURSP2022R137), Princess Nourah bint Abdulrahman University, Riyadh, Saudi Arabia. The authors would like to acknowledge the support of Prince Sultan University for paying the Article Processing Charges (APC) of this publication.

ABSTRACT In this work, a compact, light-weight, low-cost, and easy install and incorporate mmwave printed square loop antenna with a perturbed ground plane is proposed. The antenna is fabricated on an ultra-thin 0.254 mm Rogers RT/Duroid 5880 substrate. The antenna resonates between 26 GHz and 40 GHz providing the broad bandwidth of 13 GHz (~47%). First, a single element consisting of three rectangular square loops and a transmission line with total dimensions of 9 mm × 11 mm ($0.84 \lambda_0 \times 1 \lambda_0$) is designed. The loop elements are arranged on top of each other and with the further insertion of square slot in ground plane, wideband resonance response has been achieved. The antenna demonstrates gain of more than 3.3 dBi, and radiation and a total efficiency of 98% at 28 GHz. The proposed design enables spatial diversity and minimize the effects of interference between adjacent channels by providing dual-beam within desired frequency band. In addition, a linear array ($18.5 \times 22.5 \text{ mm}^2$) of four elements with a traditional feeding network is also designed, simulated, and measured. The gain of the array is 10.1 dBi, while the radiation and the total efficiency is more than 92 % at 28 GHz. A brief literature review and comparison of this work with other published works is also presented. To validate the proposed design and concept, a prototype is fabricated for both, a single element, and an array. It is found that the measured results and the computed results are in good agreement. Therefore, we believe that this system will find its applications within modern mmwave communication cellular devices.

INDEX TERMS mmwave, loop elements, gain, bandwidth, antenna array.

I. INTRODUCTION

As the world progress in communication technology, 5G is standardized throughout the globe for low latency, higher capacity of a number of users and giga-bits communication. The 5G is categorized in two spectrums namely Sub6GHz [1] and mmwave [2]. As Sub6GHz is already under the immense pressure of available services, this ultimately leads to mmwave spectrum that is yet to be utilized in order to support high bandwidth and giga-bits communication. According to a study in [3] the mmwave spectrum has

The associate editor coordinating the review of this manuscript and approving it for publication was Bilal Khawaja¹.

enormous potential to become the standard future for wireless communication systems. Several bands have been allotted as unlicensed bands for mmwave communications which include O2 band ranging from 57-64 GHz, 164-200 GHz (H2O band) and licensed bands such as 28 GHz and 38 GHz bands [4]. Due to the high attenuation present in these spectrums, the antennas deployed should offer high gain and high bandwidth. There has been a number of studies by antenna designers and researchers targeting these bands [5]–[15].

In [5], a Substrate Integrated Waveguide (SIW) fed antenna array is proposed. The gain of the array is around 14dBi and the total dimensions of antenna array are $63 \times 70 \text{ mm}^2$. The array offers good radiation characteristics with low side-lobes

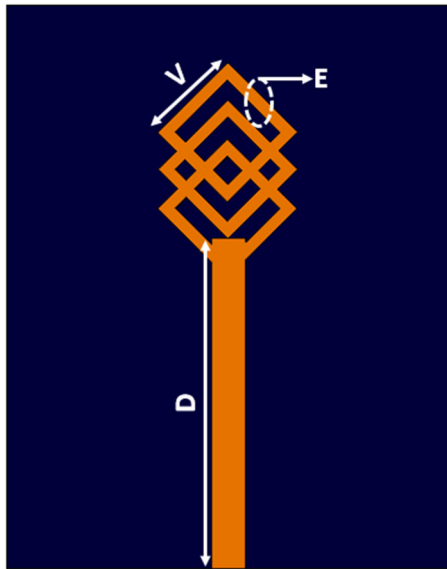

(a)

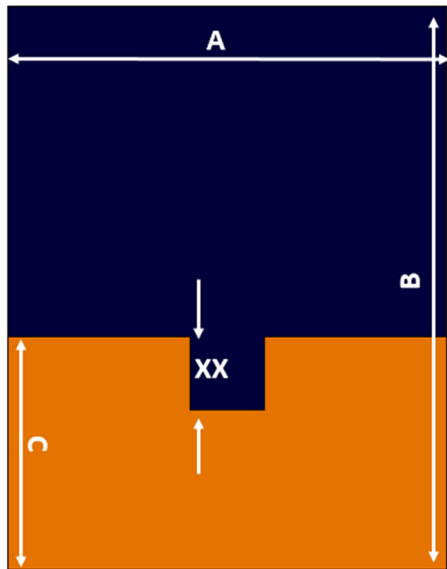

(b)

FIGURE 1. The proposed single element. (a): Front view. (b): Back view.

TABLE 1. Antenna parameters.

Parameter	Value	Parameter	Value
A	9	E	1.5
B	11	V	1.5
C	4.75	XX	1.5
D	6.75		

but the bonding films and vias assembly makes antenna challenging to embed in RF circuits. In [6] a sixteen element SIW is proposed covering frequency from 35.7 to 38GHz (4.4%) with maximum peak gain of approximately 18dBi. Similarly, in [7] a high bandwidth antenna array is presented with a

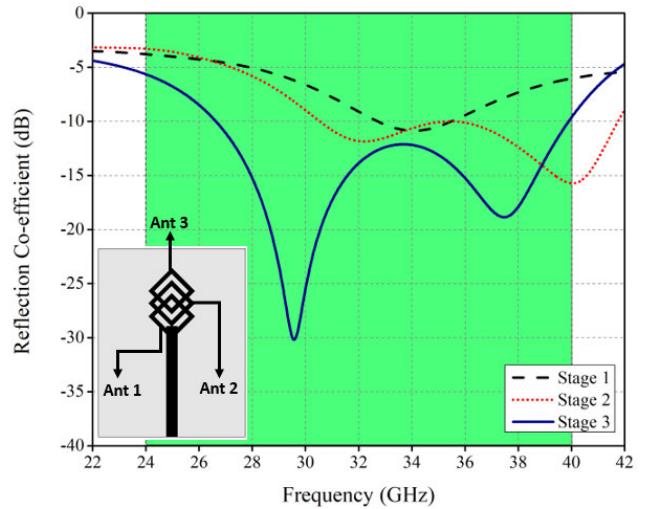

(a)

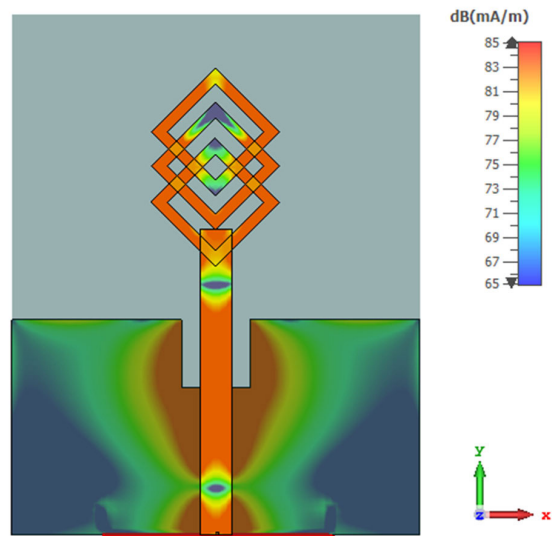

(b)

FIGURE 2. (a) Design evolution. (b) Surface currents at 28 GHz.

complex structure. A two layer 8×8 SIW feeding network is proposed in [8] providing 26dBi gain with 16% impedance bandwidth ranging from 35.5 to 41.7GHz. As compared to SIW, planar antennas are simple structures that offer low costs are preferred. A four element antenna array with a feed network in [9] provides gain ranging in between 7.8 to 11dBi for bandwidth from 26 to 30GHz. Similarly, in [10] a nature inspired four element snowflake antenna array provides 5.03% impedance bandwidth at central frequency of 28GHz while exhibiting dual beam response. A 9-element phased array is reported in [11], which exhibits a gain of nearly 15 dBi. The structure is simple with a small size of 400 mm^2 , but the offered bandwidth is very low. In [12] a donut shape mmwave four element antenna array is presented. The size of the array is $20 \times 22 \text{ mm}^2$ and the bandwidth offered is 4GHz with a central frequency of 28GHz. A four element MIMO array in [13] shows

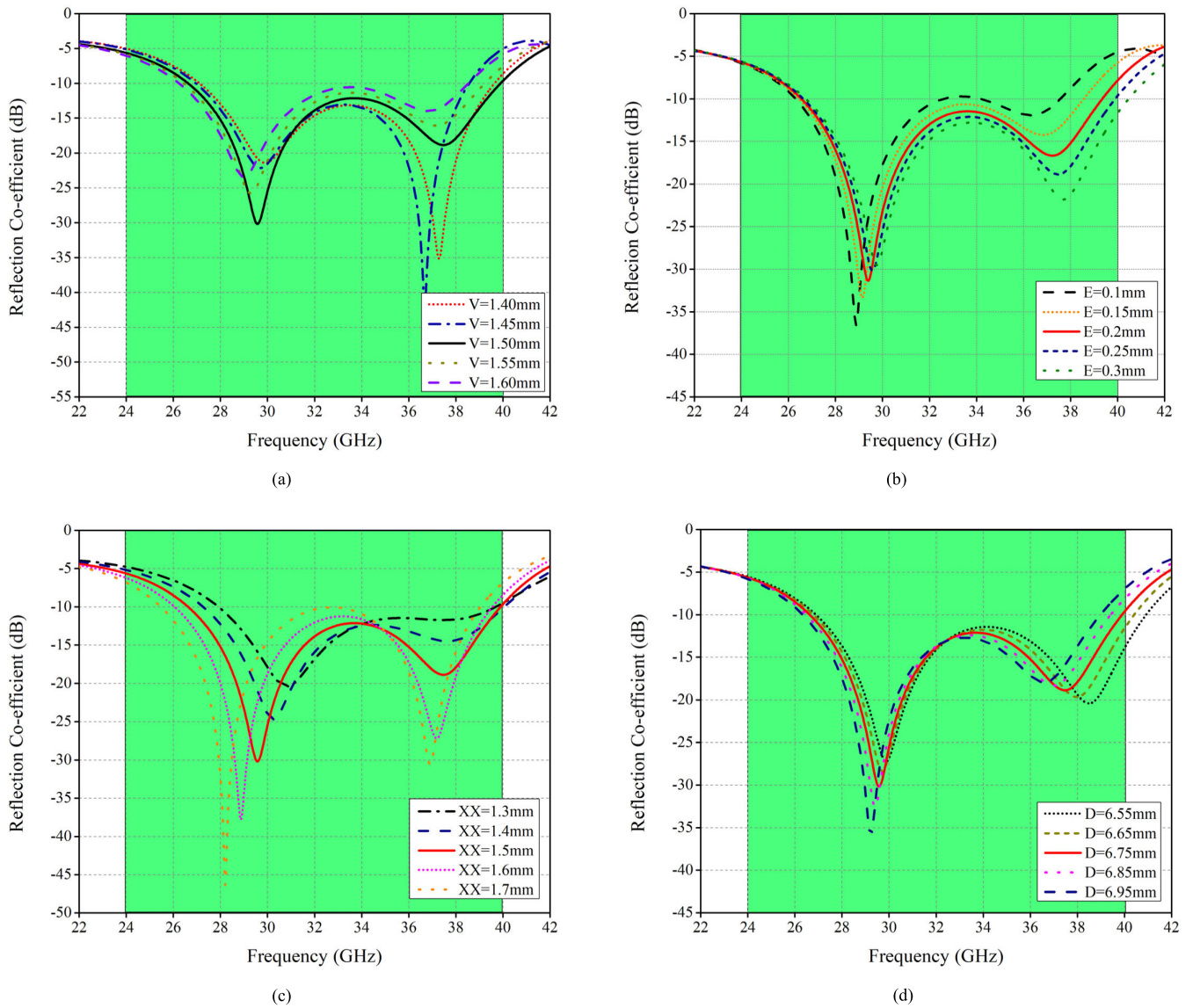

FIGURE 3. Parametric analysis of the proposed system of parameters. (a): Side length of the loop,V. (b): Width of the loop,E. (c): Width of the slot,XX. (d): Length of the transmission line,D.

bandwidth of 3GHz with the central frequency of 38GHz with maximum gain of 6.5dB. In [14] a dual band 2×2 antenna array showed peak gain of 11dB at resonance frequencies of 28 and 38GHz but the reported bandwidth was very low. In [15] authors presented a simple planar array with narrow beam width characteristics. In mmwave antenna arrays and MIMO configurations, the isolation enhancement can be achieved using different techniques such as orthogonal placement, slotted stubs, metamaterials and Electromagnetic band gap (EBG) structures [16]–[22]. In arrays the inter-element spacing can be kept at 1λ distance to avoid coupling.

As mentioned earlier, modern communication devices consist of different systems and sub-systems, and with the evidence of 5G, these systems are eager to have high data rates and throughputs. To address the aforementioned challenges

and fill the gap at the system level, we propose a simple, low-cost, light-weight, and easy to fabricate and integrate the solution. This is also the motivation behind this work. The main contribution of the presented system is wider bandwidth (13 GHz), high gain (10.1 dBi) and efficiency (98%), and dual beam characteristics within the mmwave (27 GHz to 40 GHz) frequency band. In addition, to enhance gain, a linear array with a compact size of $18.5 \times 22.5 \text{ mm}^2$ ($1.8 \lambda_0 \times 2 \lambda_0$) is proposed as well. Based on the performance characteristics, simplicity and advantages inherited by design as compared with the available literature, it suggests that this antenna could be used as a potential solution where dual-beam characteristics, spatial diversity, and minimal interference between adjacent communication channels are desired. Next, antenna design, working principle, and key performance parameters are discussed in detail.

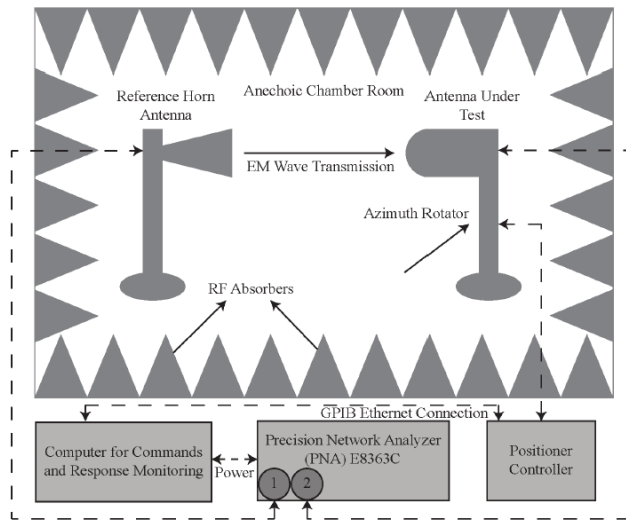

FIGURE 4. Measurement setup.

II. ANTENNA DESIGN

Figure 1 shows the front- and the back-view of the single element. This single element is designed on a double-sided very thin 0.254 mm Rogers RT/Duroid 5880 substrate with a dielectric constant of 2.2 and a loss tangent of 0.0009. The thickness and the conductivity of the copper are 1 oz and 5.8×10^7 S/m, respectively. A transmission line and three interconnected rectangular square loops are etched on the upper side, while a perturbed ground plane with a square slot is printed on the lower side of the substrate. The geometrical dimensions of different segments of the presented antenna are also labeled in Fig. 1, while values for each variable are given in Table-1.

First, a 50Ω transmission line is designed on the upper side with a full ground plane on the other side of the substrate. Next, a square loop shell is added at one of the ends of the transmission line and then tilted at 45° with a half ground plane on the other side of the board and a resonance at 34 GHz is found. To improve the impedance of the element, another square loop shell is incorporated with the previous design, and two resonances are identified. Lastly, three tilted square loop shells are incorporated with the transmission line. Similarly, the half ground plane with a rectangular slot is designed on the other side. This design helps to have symmetric currents at the either side of structure, if it is half-cut in the middle along the y-axis, providing dual-beam characteristics with an ultra-wide band response, as shown in Fig. 2. In other words, by feeding the structure, the current flows through the transmission line, and is distributed equally and symmetrically within the loops (or mirror images of each other). Since the upper side is symmetric along y-axis, symmetric currents flow through the ground plane enabling wider bandwidth and similar beam characteristics in either direction.

To further demonstrate the effects of each variable within the presented design, a detailed study is conducted and illustrated in Fig. 3. It is found that by varying the side length (V)

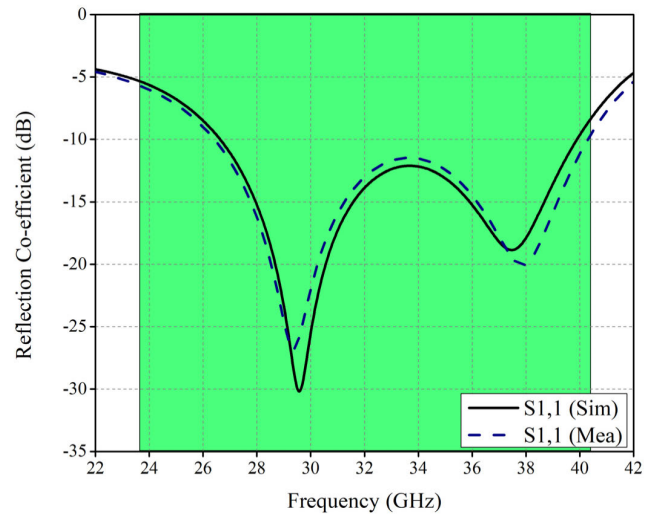

(a)

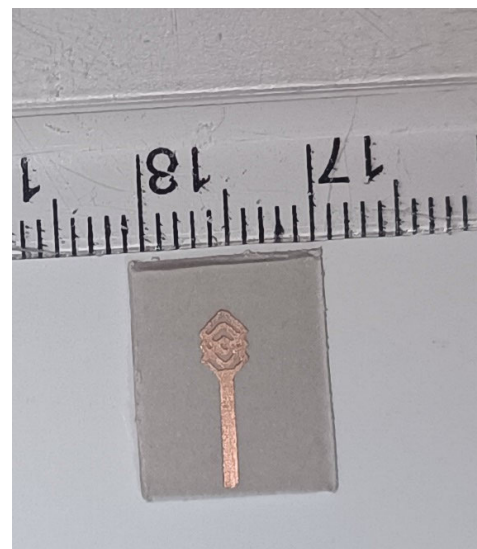

(b)

FIGURE 5. (a) Simulated and measured S-parameter of single element. (b) Single element fabricated prototype.

of the loop the impedance of the antenna changes and two prominent resonances can be seen at 29 GHz and 37 GHz, respectively. In other words, this parameter provides flexibility to identify and control resonances within the desired frequency band. Similarly, the width of the square shells (E) plays an important role to defining the bandwidth of the structure. This parameter is varied between 0.1 mm and 0.3 mm, with a step size of 0.05 mm, and similar observations are valid for the width of the slot width (XX). Lastly, the length of the transmission line (D) helps to understand the improvement in the impedance of the proposed radiating element, providing control to adjust the impedance of the design.

Figure 4 shows the measurement setup. To validate the concept, an antenna is fabricated using LDKF D104 and

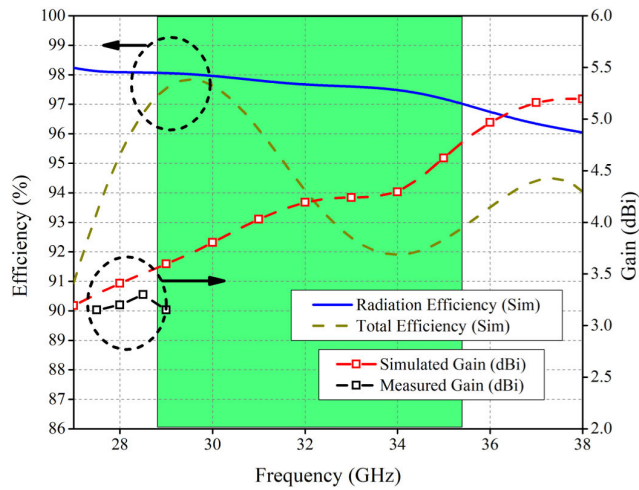
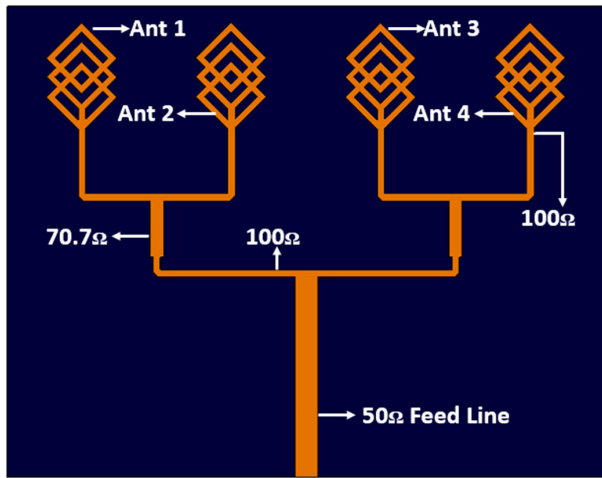
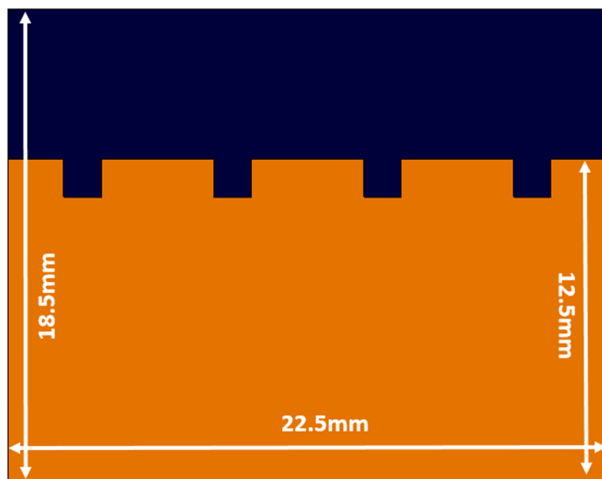

FIGURE 6. Performance parameters of single element.



(a)



(b)

FIGURE 7. The proposed array configuration. (a): Front view. (b): Back view.

measured with an Anritsu vector network analyzer. Figure 5 illustrates the measured prototype and a comparison between

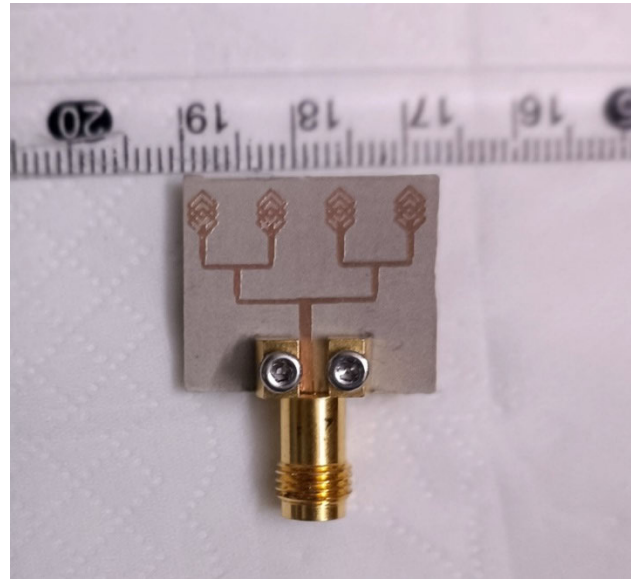

(a)

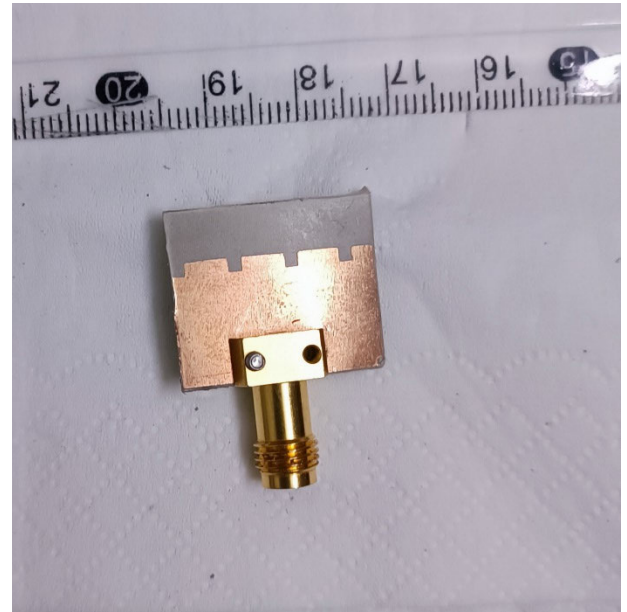

(b)

FIGURE 8. Fabricated array prototype (a): Front view. (b): Back view.

the measured and the simulated results. It is found that the results are in very good agreement providing 13 GHz (~47%) bandwidth ranges between 27 GHz and 40 GHz. The simulated and measured results for the gain and the computed efficiency of the system are given by Fig. 6 and are in very good agreement. The gain of the antenna is more than 3.3 dBi and both the radiation and the total efficiencies are around 98% at 28 GHz.

III. ARRAY CONFIGURATION

To demonstrate the advantages, flexibility, and robustness inherited by the proposed design, and as an advancement,

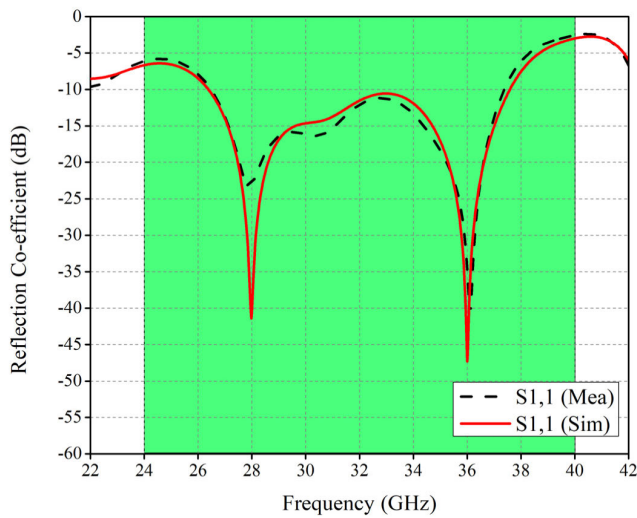

FIGURE 9. Simulated and measured return loss of the proposed array.

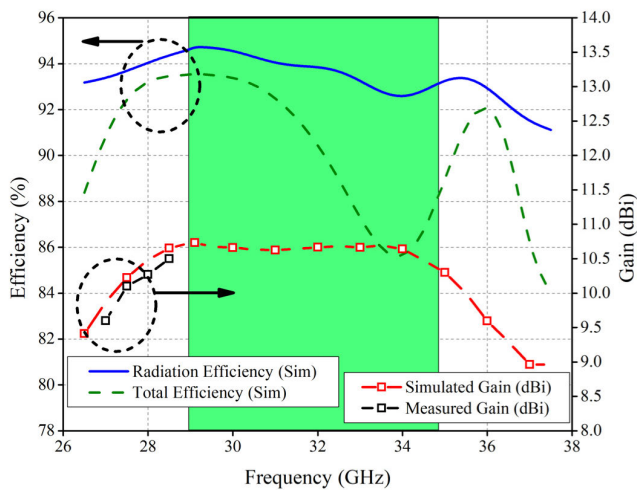

FIGURE 10. Performance parameters of proposed array.

a 1×4 linear array with a traditional yet compact feeding network is configured, as shown in Fig. 7. The dimension of the array is $18.5 \times 22.5 \text{ mm}^2$ ($1.8 \lambda_0 \times 2 \lambda_0$), and the center-to-center distance between any two radiating element is less than $0.7 \lambda_0$ at 28 GHz. Four radiating elements and feeding network are etched on the upper side of the substrate. The feeding network consists of transmission lines, junctions, and angular bends. Similarly, the lower side of the board has a perturbed ground plane with four rectangular slots. The same substrate as the one in the single element is used with the same material and dimensional properties.

Figure 8 shows the fabricated prototype of four element array while Figure 9 represents a comparison between the measured and the simulated return loss of the feeding port which is well below -10 dB for the whole operating range. This is due to the fact that this design is not only compact but also efficient in terms of losses. It is evident from Figure.9; that they are in a good agreement providing very wide

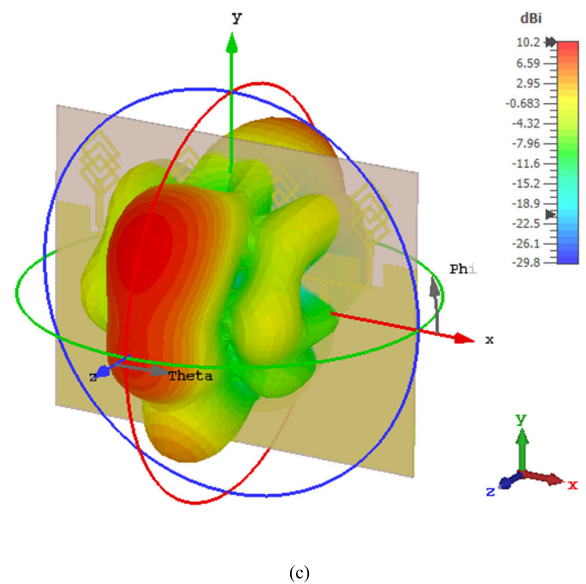
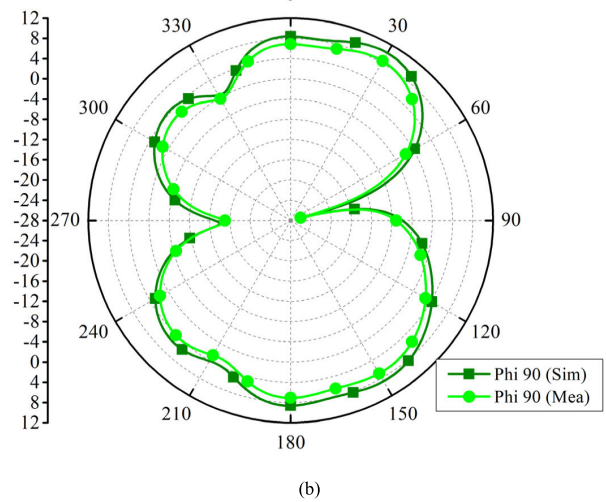
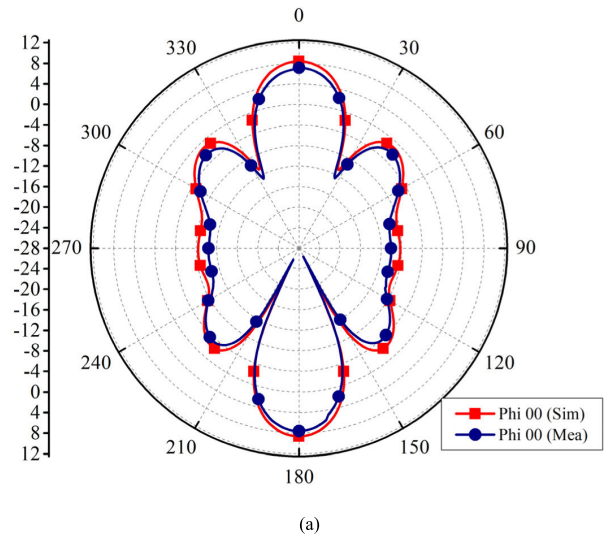

FIGURE 11. Far-field patterns of the proposed array configuration. (a): xz-plane. (b): yz-plane. (c) 3D pattern.

TABLE 2. Proposed antenna performance comparison with published work.

Ref	Frequency Range (GHz)	Size mm ² (LxW)	Gain (dBi)	Efficiency (%)	Complexity
[5]	27.3-29.6	63 x 70	13.97	≥60	High
[6]	35.4-37	N/A	17	≥75	High
[9]	26.04-30.63	40 x 19.22	11.2	≥83	High
[10]	27.258-28.26	32 x 12	10.5	≥80	Low
[12]	26-30	20 x 22	10	≥80	Low
[15]	25-34.9	45 x 20	12	≥85	Low
Proposed	26-37.9	22.5 x 18.5	10.02	≥82	Low

bandwidth of around 12 GHz (~46%). Similarly, Figure. 10 illustrates simulated and the measured gain which is more than 10 dBi at 28 GHz, and the radiation and the total efficiency is found to be more than 90%. It can be argued that since the loss tangent of the substrate is very low (0.0009), therefore, such a high efficiency is computed.

To demonstrate the dual beam characteristics, far-field attributes for both the xz - and yz - planes are shown in the Fig. 11. In addition, for the sake of completeness, a 3D pattern of the radiation properties is also depicted in Fig. 11. From Fig. 11, it is observed that for $\phi = 0^\circ$ plane, the proposed system radiates in all directions with nulls located at the top and bottom of the array plane. Similarly, $\phi = 90^\circ$ plane, the radiation characteristics are directive and are in the front and bottom side of the antenna. Furthermore, the half power beamwidth of the system is 19° , which makes it suitable for mmwave communication in various future cellular and personal networks, and where spatial diversity and minimal adjacent channels interference is desired.

To further demonstrate that the presented work is advanced, compact, and poses numerous advantages as compared to the similar studies available in the published literature, a detailed comparison of this work with the available works is conducted and illustrated in Table 2. Based on the key performance characteristics, design, simplicity, and size, we are confident that the proposed model has potential to be a useful mmwave antenna array for future 5G and beyond modern communication systems.

IV. CONCLUSION

In this paper a wideband four element linear array that is simple, light-weight, compact, economical, and simple to construct is presented. The proposed model is constructed on a Rogers RT/Duroid 5880 substrate with a thickness of 0.254 mm. The antenna resonates between 26 GHz and 40 GHz, offering a broad bandwidth of 13 GHz (about 47 percent) over a wide frequency range. Half-ground planes with rectangular slots are present in both the single element

and the array. Its single element measures 9 mm in height by 11 mm in width, while the array measures 18.5 millimeters by 22.5 millimeters in length. At 28 GHz, the single antenna achieves a gain of more than 3.3 dBi, as well as radiation and total efficiency of 98%, while the array configuration achieves a gain of 10.1 dBi, as well as total and radiation efficiency of more than 92%. Through dual-beam characteristics within the desired frequency band, the proposed design allows for greater spatial diversity while also reducing the impacts of interference between adjacent channels. In addition, a brief overview of the literature and a comparison of this work with other previously published studies are provided for our consideration. Both a single-element and an array prototype are built to verify the proposed design. Findings are consistent between measured and calculated outcomes. We believe that this system will be used in mmwave communication devices in the future.

ACKNOWLEDGMENT

Princess Nourah bint Abdulrahman University Researchers Supporting Project number (PNURSP2022R137), Princess Nourah bint Abdulrahman University, Riyadh, Saudi Arabia. The authors would like to acknowledge the support of Prince Sultan University for paying the Article Processing Charges (APC) of this publication.

REFERENCES

- [1] M. Alibakhshikenari, B. S. Virdee, C. H. See, P. Shukla, S. M. Moghaddam, A. U. Zaman, S. Shafqaat, M. O. Akinsolu, B. Liu, J. Yang, R. Abd-Alhameed, F. Falcone, and E. Limiti, "Dual-polarized highly folded bowtie antenna with slotted self-grounded structure for sub-6 GHz 5G applications," *IEEE Trans. Antennas Propag.*, early access, Oct. 14, 2021, doi: [10.1109/TAP.2021.3118784](https://doi.org/10.1109/TAP.2021.3118784).
- [2] M. Alibakhshikenari, S. M. Moghaddam, A. U. Zaman, J. Yang, B. S. Virdee, and E. Limiti, "Wideband sub-6 GHz self-grounded bow-tie antenna with new feeding mechanism for 5G communication systems," in *Proc. 13th Eur. Conf. Antennas Propag. (EuCAP)*, 2019, pp. 1–4. (Aug. 2015). *5G Spectrum Recommendations*. [Online]. Available: <http://www.5gamericas.org>
- [3] K. Raheel, A. Altaf, A. Waheed, S. H. Kiani, D. A. Sehrai, F. Tubbal, and R. Raad, "E-shaped H-slotted dual band mmWave antenna for 5G technology," *Electronics*, vol. 10, no. 9, p. 1019, Apr. 2021.
- [4] S.-J. Park, D.-H. Shin, and S.-O. Park, "Low side-lobe substrate-integrated-waveguide antenna array using broadband unequal feeding network for millimeter-wave handset device," *IEEE Trans. Antennas Propag.*, vol. 64, no. 3, pp. 923–932, Mar. 2016.
- [5] B. Hammu-Mohamed, Á. Palomares-Caballero, C. Segura-Gómez, F. G. Ruiz, and P. Padilla, "SIW cavity-backed antenna array based on double slots for mmWave communications," *Appl. Sci.*, vol. 11, no. 11, p. 4824, May 2021.
- [6] P. N. Choubey, W. Hong, Z.-C. Hao, P. Chen, T.-V. Duong, and J. Mei, "A wideband dual-mode SIW cavity-backed triangular-complimentary-split-ring-slot (TCSRS) antenna," *IEEE Trans. Antennas Propag.*, vol. 64, no. 6, pp. 2541–2545, Jun. 2016.
- [7] X. Li, J. Xiao, Z. Qi, and H. Zhu, "Broadband and high-gain SIW-fed antenna array for 5G applications," *IEEE Access*, vol. 6, pp. 56282–56289, 2018.
- [8] H. Ullah and F. A. Tahir, "A broadband wire hexagon antenna array for future 5G communications in 28 GHz band," *Microw. Opt. Technol. Lett.*, vol. 61, no. 3, pp. 696–701, Mar. 2019.
- [9] H. Ullah and F. A. Tahir, "A novel snowflake fractal antenna for dual-beam applications in 28 GHz band," *IEEE Access*, vol. 8, pp. 19873–19879, 2020.
- [10] M. Khalily, R. Tafazolli, T. A. Rahman, and M. R. Kamarudin, "Design of phased arrays of series-fed patch antennas with reduced number of the controllers for 28-GHz mm-wave applications," *IEEE Antennas Wirel. Propag. Lett.*, vol. 15, pp. 1305–1308, 2016.

- [12] M. M. Kamal, S. Yang, S. H. Kiani, M. R. Anjum, M. Alibakhshikenari, Z. A. Arain, A. A. Jamali, A. Lalbakhsh, and E. Limiti, "Donut-shaped mmWave printed antenna array for 5G technology," *Electronics*, vol. 10, no. 12, p. 1415, Jun. 2021.
- [13] D. A. Sehrai, M. Asif, N. Shoaib, M. Ibrar, S. Jan, M. Alibakhshikenari, A. Lalbakhsh, and E. Limiti, "Compact quad-element high-isolation wide-band MIMO antenna for mm-wave applications," *Electronics*, vol. 10, no. 11, p. 1300, May 2021.
- [14] J. Khan, D. A. Sehrai, and U. Ali, "Design of dual band 5G antenna array with SAR analysis for future mobile handsets," *J. Electr. Eng. Technol.*, vol. 14, no. 2, pp. 809–816, Mar. 2019.
- [15] H. Ullah and F. A. Tahir, "A high gain and wideband narrow-beam antenna for 5G millimeter-wave applications," *IEEE Access*, vol. 8, pp. 29430–29434, 2020.
- [16] M. M. Kamal, S. Yang, X.-C. Ren, A. Altaf, S. H. Kiani, M. R. Anjum, A. Iqbal, M. Asif, and S. I. Saeed, "Infinity shell shaped MIMO antenna array for mm-wave 5G applications," *Electronics*, vol. 10, no. 2, p. 165, Jan. 2021, doi: [10.3390/electronics10020165](https://doi.org/10.3390/electronics10020165).
- [17] A. Altaf, A. Iqbal, A. Smida, J. Smida, A. A. Althuwayb, S. H. Kiani, M. Alibakhshikenari, F. Falcone, and E. Limiti, "Isolation improvement in UWB-MIMO antenna system using slotted stub," *Electronics*, vol. 9, no. 10, p. 1582, Sep. 2020, doi: [10.3390/electronics9101582](https://doi.org/10.3390/electronics9101582).
- [18] A. Iqbal and O. A. Saraereh, "A compact frequency reconfigurable monopole antenna for Wi-Fi/WLAN applications," *Prog. Electromagn. Res.*, vol. 68, pp. 79–84, 2017.
- [19] A. A. Althuwayb, "Low-interacted multiple antenna systems based on metasurface-inspired isolation approach for MIMO applications," *Arabian J. Sci. Eng.*, vol. 46, pp. 1–10, May 2021.
- [20] M. Alibakhshikenari, F. Babaeian, B. S. Virdee, S. Aissa, L. Azpilicueta, C. H. See, A. A. Althuwayb, I. Huynen, R. A. Abd-Alhameed, F. Falcone, and E. Limiti, "A comprehensive survey on 'various decoupling mechanisms with focus on metamaterial and metasurface principles applicable to SAR and MIMO antenna systems,'" *IEEE Access*, vol. 8, pp. 192965–193004, 2020.
- [21] M. Alibakhshikenari, M. Khalily, B. S. Virdee, C. H. See, R. A. Abd-Alhameed, and E. Limiti, "Mutual-coupling isolation using embedded metamaterial EM bandgap decoupling slab for densely packed array antennas," *IEEE Access*, vol. 7, pp. 51827–51840, 2019.
- [22] M. Alibakhshikenari, M. Khalily, B. S. Virdee, C. H. See, R. Abd-Alhameed, and E. Limiti, "Mutual coupling suppression between two closely placed microstrip patches using EM-bandgap metamaterial fractal loading," *IEEE Access*, vol. 7, pp. 23606–23614, 2019.



SHAHID KHAN was born in Landikotal, Pakistan, in 1986. He received the B.S. degree in communication engineering from the University of Engineering and Technology, Peshawar, Pakistan, the M.S. degree in satellite navigation and related applications from Politecnico de Torino, Italy, in 2011, and the Ph.D. degree from the University de Lorraine, France. Before joining the University de Lorraine, he worked as a Lecturer with COMSATS University Islamabad, Abbottabad, from 2012 to 2017. He was also a Visiting Fellow with the 5G Innovation Center, University of Surrey. He has done work on the development of circularly polarized phased array DRAs for satellite application and reconfigurable dielectric resonator antenna for different wireless applications. He is currently serving his responsibilities as an Assistant Professor for COMSATS University Islamabad, Abbottabad Campus.



MOHAMED MAREY (Senior Member, IEEE) received the M.Sc. degree in electrical engineering from Menoufia University, Egypt, in 1999, and the Ph.D. degree in electrical engineering from Ghent University, Belgium, in 2008. From 2009 to 2014, he was a Research Associate and a Visiting Professor with the Faculty of Engineering and Applied Science, Memorial University, Canada. He is currently a Full Professor with the Faculty of Electronic Engineering, Menoufia University.

He is on a sabbatical leave in order to join Prince Sultan University, Saudi Arabia, as the Research Laboratory Leader of the Smart Systems Engineering Laboratory. He has authored the book *Multi-Carrier Receivers in the Presence of Interference: Overlay Systems* (VDM Publishing House Ltd., 2009) and around 100 scientific papers published in international journals and conferences. His research interests include wireless communications and digital signal processing, with a particular focus on smart antennas, cooperative communications, signal classification for cognitive radio systems, synchronization and channel estimation, multiple-input multiple-output antenna systems, multicarrier systems, and error-correcting codes. He was a recipient of the Young Scientist Award from the International Union of Radio Science, in 1999.

HALA MOSTAFA received the Ph.D. degree in electrical engineering from the Faculty of Engineering and Applied Science, Memorial University, Canada, in 2014. From 2014 to 2015, she was a Research Scientist with Memorial University. She is currently an Assistant Professor with the Department of Information Technology, College of Computer and Information Sciences, Princess Nourah bint Abdulrahman University, Riyadh, Saudi Arabia. Her research interest includes wireless communications, with a particular focus on smart antennas and wireless sensor networks.



MUHAMMAD AMIR KHAN received the M.S. degree in computer engineering from COMSATS University Islamabad, Abbottabad, Pakistan, and the Ph.D. degree in information technology from Universiti Teknologi PETRONAS, Malaysia. He is an Assistant Professor with the Computer Science Department, COMSATS University Islamabad. He has published more than 23 research papers in ISI/impact factor journals and international conferences. His research interests

include communication protocols for the Internet of Things (IoT), wireless sensor networks, wireless *ad-hoc* networks, 5G antenna designs, and software-defined network (SDN).

...



SAAD HASSAN KIANI received the bachelor's degree from the City University of Science and Information Technology, in 2014, and the master's degree from Iqra National University, Peshawar, Pakistan, in 2018. He is currently pursuing the doctoral degree with the IIC University of Technology, Cambodia. His research interests include MIMO antenna designs, 5G antennas, mmwave antennas, isolation enhancement among MIMO antenna elements, and origami and kirigami antennas.



ABDULLAH G. ALHARBI (Member, IEEE) received the B.Sc. degree in electronics and communications engineering from Qassim University, Saudi Arabia, in 2010, the master's and Ph.D. degree in electrical engineering from the University of Missouri-Kansas City, USA, in 2014 and 2017, respectively. From 2010 to 2012, he was an Electrical Engineer with Saudi Aramco Company. He is currently an Assistant Professor with the Electrical Engineering Department, Jouf University, Saudi Arabia. He authored and coauthored over 45 journals and conference papers and one Springer book. His research interests include digital IC design, memristor-based circuits, nano electronics, network routing, green communications, and wireless communications. He is a member of the Gulf Engineering Union, the IEEE Circuits and Systems Society, the IEEE Young Professionals, the IEEE Signal Processing Society, the IEEE Instrumentation and Measurement Society Membership, and the IEEE Communications Society Membership, and a Professional Member of ACM. He was a recipient of several awards from Saudi Arabian Cultural Mission in USA and the University of Missouri-Kansas City.