

Received November 18, 2021, accepted December 22, 2021, date of publication December 30, 2021, date of current version January 20, 2022.

Digital Object Identifier 10.1109/ACCESS.2021.3139544

Development of Innovative Operational Flexibility Measurement Model for Smart Systems in Industry 4.0 Paradigm

AHMAD SAJJAD¹, WASIM AHMAD¹, SALMAN HUSSAIN¹,
AND RAJA MAJID MEHMOOD², (Senior Member, IEEE)

¹Engineering Management Department, University of Engineering and Technology Taxila, Taxila 47080, Pakistan

²Information and Communication Technology Department, School of Electrical and Computer Engineering, Xiamen University Malaysia, Sepang 43900, Malaysia

Corresponding author: Raja Majid Mehmood (rmeex07@ieee.org and rajamajid@xmu.edu.my)

This work was supported in part by the Directorate of Advanced Studies Research and Technology Development, University of Engineering and Technology, Taxila, Pakistan; and in part by the Xiamen University Malaysia Research Fund (XMUMRF) under Grant XMUMRF/2019-C3/IECE/0007.

ABSTRACT The exponential growth of cutting-edge technologies continuously pushing the manufacturing industry into the paradigm of smart manufacturing. Smart manufacturing provides the pace of highly competitive market demand and customized intensive production. The goal of smart manufacturing technologies embedded systems in the Industry 4.0 paradigm and lean production is to enhance the flexibility in all tears of the enterprise. It is a big challenge, to measure the flexibility of smart systems for decision-making and adaptation of the new manufacturing technologies. The conceptual architecture of smart manufacturing systems has been proposed to solve the problem. Operational flexibility has been measured using a mathematical model for smart manufacturing in the Open Platform Communication Unified Architecture enabled Cyber-Physical Production System at shop floor level and validated. The results obtained from experimentation depict the operational flexibility, maximum capacity, and breakeven point of the manufacturing system have been improved by using smart manufacturing technologies. The proposed model improves the product manufacturing using Smart Computer Numeric Control Machining, Smart Autonomous Robotic Machining, Smart Additive Manufacturing and Smart Hybrid Additive & Subtractive Manufacturing up to 30.4%, 53.6%, 55% and 65% respectively. It will also help the decision-makers to overcome the challenges of transformation from conventional to smart manufacturing industry 4.0 paradigm.

INDEX TERMS Additive manufacturing, computer numerical control, cyber-physical system (CPS), direct metal laser sintering-DMLS, industry 4.0, industrial robots, Internet of Things (IoT), operational flexibility, smart manufacturing.

I. INTRODUCTION

In the era of intense market competition for high quality, cost-effective, and customize production, manufacturing industries are trying hard to transform existing manufacturing systems to industry 4.0 or smart manufacturing. The Industry 4.0 short form of fourth Industrial revolution attributed to the latest and most sophisticated manufacturing paradigm enabled with the exponential technologies. These exponential technologies such as Internet of Things (IoT), cyber physical system (CPS), smart sensors, adaptive robots, 3D

printer, Cloud Computing big data and virtual reality. These devices are interconnected, interlinked through unique identity on heterogeneous wireless network. Internet of Things provides the decentralized and autonomous systems architecture in loosely coupled network which sense the physical phenomenon's using smart sensors/actuators. Embedded devices covert the physical processes into digital data in real-time and stored in the cloud infrastructure. Industrial IoT functionalities are not limited to data acquisition, data processing and storing capabilities. Internet of things provides the controlling capabilities to design the cyber physical production systems (CPPS) and machine to machine communication architecture. But the question is how the

The associate editor coordinating the review of this manuscript and approving it for publication was Hang Shen¹.

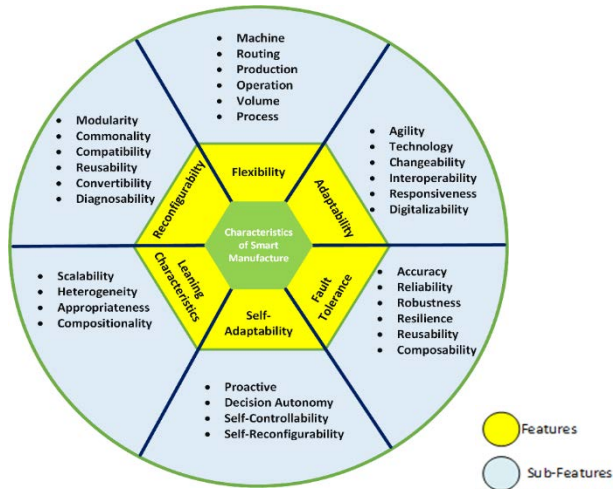

FIGURE 1. Characteristics and Sub features of industry 4.0.

transformation will be performed and what be the model or framework for this servitization. The design principles of smart manufacturing i.e. modularity, interoperability, decentralization, virtualization, real-time capabilities, and service orientation provide the bases to build a robust foundation to design or transform the existing systems into smart manufacturing [1]. These set and well-defined design principles of smart manufacturing (SM) pose some characteristics, associated technologies, and enabling factors. The definition of characteristic will be the distinctive property of any system or product to make it distinguish from other elements or give the vision of difference or similarity. In the case of smart manufacturing characteristics named as flexibility, adaptability, and reconfigurability. Technology is referred to as the practical implementation of science and its rules to address any real-world issue by the development of products or services. Technologies involved in smart manufacturing are cloud computing & manufacturing, 3D printing, IIoT (Industrial Internet of Things), and cyber-physical production systems (CPPS), etc. Technology is an indispensable function in system development regarding smart manufacturing either it provides bases or pillars the whole system. Enabling factors are pertaining to the rules, procedures, regulations, policies, standards, and managerial practices involved during the implantation and sustaining the system functionality. In a smart manufacturing system requires some factors during the implementation of characteristics and technologies in the system, these factors include innovation, training, laws, and regulations. The main characteristics of smart manufacturing system design are adaptability, flexibility, self-adaptability, learning characteristics and fault tolerance, etc. These characteristics are the building blocks for the manufacturing system to transform into smart manufacturing. These design features are expressed in the sub-features by multiple authors like [2]–[12] are summarized in Figure 1.

The similar characteristics are shown by lean production system including flexibility, adaptability, agility and automa-

tion. The lean production system is attributed as the successful paradigm for high quality production and waste elimination. The emergence of industry 4.0 paradigm has change the dynamics of production. The lean production has some limitations including less flexible, limited dynamic demand driven production and less ICT integration. The industry 4.0 technologies have potential to transform the lean production system. It is a major challenge for enterprises to align the lean and Industry 4.0 operational strategies in changing the environment. At operational level requires robust methodology and concepts to transform lean management in technology projects of Industry 4.0. The proper models and roadmap frameworks are missing to guide the enterprise at the operational decision level.

The common characteristic of lean and Industry 4.0 is the flexibility. The flexibility is an important characteristic of smart system. Flexibility may define as the capability of any system to adjust and operate despite its changing requirement in the state, space, motion at cost of less time, resources with maximum operational performance [13]. Ten types of flexibility related to manufacturing and production systems have been identified from literature ([14], [15]). Koste and Malhotra [16] categorize of ten types of flexible’s into four levels in manufacturing systems including enterprise/functional, plant/factory, shop floor, and individual levels. The flexibility measurement for modern systems like smart manufacturing under a lean environment has not been yet measured and assessed. At shop floor level operational flexibility has been measured and calculated in a flexible manufacturing system (FMS) by Juan Jose Pelaez-Ibarrondo [17]. Smart manufacturing is needed transformation in all levels of an enterprise including Plant level and shop floor level. This research paper will focus on the calculation of the enabling factor to transform the shop floor with flexibility under a smart and lean environment. The concept of lean Kaizen, agility, and flexibility have the same meaning. The difference is only in the perception of various field experts. Management experts consider any change in system and transformation as Kaizen and Agility, on the other hand, system design experts, called this flexibility of the system. Lean as a management philosophy has been attributed as the best strategy for process improvement since its inception. The lean manufacturing paradigm primarily focused on waste reduction in the production system to eliminate overproduction, cost reduction, and transportation. The same functionality has been aimed at a new type of manufacturing called smart manufacturing. This smart paradigm is also focused on process improvement initiatives and strategies by adopting digital technologies. These sophisticated exponential technologies orchestrate the connectivity and integration of all peers of the manufacturing system to facilitate streamlined production. Indeed, Lean manufacturing and smart manufacturing are complementary to each other and have a vital role to reinforce the strategies for the factory of the future. Before making collaborative strategies for lean and smart manufacturing systems, it is most important to highlight the implementation gaps and get

a fine understanding of smart manufacturing deployment in the production system. [18].

The contribution of this paper is (i) proposed the novel conceptual model of Cyber Physical Production System for shop floor integrated Open Platform Communication Unified Architecture. (ii) The first study to formulate mathematical modelling based operational flexibility measurement model of smart manufacturing in scheduled production (iii) A new method has been developed to integrate the energy cost estimation mechanism in decision making process using operative data of smart systems parameters (iv) The effectiveness of proposed mechanism has seen in the form of impressive improvement has been observed in operational flexibility, maximum capacity and break-even point after validation from industrial case.

The rest of the paper is structured as follows. Section 2 illustrate the brief introduction related to topic. Section 3 pertains to literature review related to Industrial IoT enabled CPPS in Industry 4.0 environment and description of problem in adoption of smart manufacturing design. Section 4 describes research methodology related to model purpose, the flexibility measurement of the proposed model. Section 5 validation by evaluating the results of an industrial case study, whereas Section 6 concludes the presented work.

II. LITERATURE REVIEW

Smart manufacturing provides workshop managers with useful insights to use data and information to improve the flexibility and responsiveness of the manufacturing process to quickly and cost-effectively change the needs in the enterprise [19]. The distinguishing feature of the intelligent manufacturing system is the flexibility of resource supply. The key business and technical considerations for the implementation of intelligent manufacturing systems include but are not limited to automation, industrial control systems, service portfolio, flexibility, business models, and recommended implementation models and architectures. In the smart manufacturing environment, the manufacturing supply chain relationship will be customer-centric and defined by improving efficiency. Reduce costs, increase flexibility and enhance user functionality [20]. The intelligent manufacturing system with data life cycle and real-time monitoring functions can deploy flexibility and adaptability in project changes or personalized awareness environments [21]. The real-time capability facilitates collecting and analyzing the data generated in the physical world, helps to control the manufacturing processes which make the traditional rigid manufacturing process more and more flexible [22]. For example an adaptive intelligent collaboration of advanced robots provides a high degree of modularity and flexibility for the intelligent manufacturing system framework [23]. The future European manufacturing report points out that future manufacturing companies will rely more on flexibility and low cost [24].

In the fourth industrial revolution, the gap between physical and virtual processes is going to be depleted. A new

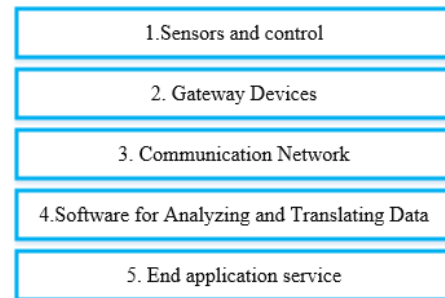

FIGURE 2. IoT ecosystem components.

transformed shape of modern manufacturing paradigm has been emerged, in which systems become more intelligent and smarter. The machine becomes autonomous, self- controlled, self-derived, and self-decision. The real-time system capabilities getting more popular and system intelligence framework become effective using modern technologies of information & communication [25]. Machines and related physical activities are now more integrated with the connected environment and minimize the humanized intervention. This connectivity, communication, control coverage, and cognition makes the self- controlled system called Cyber-Physical Production System (CPPS), attributed to the beginning of industry 4.0 [26]. CPPS is a modern smart control system that monitors all interconnected embedded smart physical systems, processes, and devices. This connectivity and coverage provide the virtual footprint of the system because of an enormous amount of data generated.

The abundance of data gathered called Bigdata. All decisions related to system operation, monitoring, and control are taken by using useful attributes of bigdata. The bigdata stored in cloud computing infrastructure for data analytics. Data analytics and algorithms used to extract useful features from this data and convert them into meaningful information. Based on this information, data processing help in decision making, which makes the CPPS smarter [27]–[29]. The process of data generation started from the sensing of data from the physical environment. High-end smart sensors are used to sense the data pass on to embedded devices through the industrial internet of things (IIoT) infrastructure. Industrial IoT is an integral part of CPPS for data sensing and communication. Embedded devices e.g smart sensors, actuators, and robots are interconnected with IoT gateway using the internet as shown in Figure 2. It is evident that use of smart systems, integrated with IoT are the need of every system to transform from conventional to smart paradigm [30]. CPPS can be represented in the form of a mathematical function as in equation (1) [31].

$$CPPS = f(\text{Sense, Connect, Content, Control, Share}) \quad (1)$$

CPPS is a combination of key technologies that provide strength to industry 4.0 emergence. These exponential technologies are, industrial internet of things (IIoT), big data

analytics, Cloud-native computing (CnC), Simulation & digital twin, autonomous robots, Augmented & virtual reality (AR & VR), Cyber-Security, 3D printing. The ecosystem made by a combination of one or more technologies for the manufacturing system and treated as the sub-set of Cyber-Physical System (CPS) called Cyber-Physical Production System CPPS. [26], [32], [33]. It is observed multiple times in literature, the implementation architecture of CPPS is a 5C model [34]. CPPS is implemented in a layered combination called 5C architecture. This architecture provides a general guideline regarding the implementation of CPPS. These design features are related to connectivity, communication, cyber, cognitive, and configuration control of embedded systems [27]. Industrial IoT is considered a vital and integral part of CPPS [28]. IoT enabled system is a combination of smart sensors, embedded devices, IoT gateway, edge devices, and cloud integration. Smart sensors collect real-time data from physically connected embedded devices. This data has been exchanged with the cyber world through some IoT protocol governed by the IoT gateway. IoT infrastructure provides connectivity to every “thing” that connects to the internet and made data communication. In industry 4.0 manufacturing paradigm intensive digitization, computation, commination, and data processing machines become smarter and intelligent. This paradigm is self- controlled, machines that are aware of its predictive maintenance, inspection capabilities, and real-time monitoring of operations. It is all possible due to the IoT systems which provide real-time and authentic data to CPPS and intelligent control smoothly run the function [35]. IoT is an acronym of industrial internet of things and attributed as the subcategory of IoT dedicated and designed for industrial automation applications. Typically, IoT provides connectivity and integration to the smart sensors, actuators, robots, processing machines, and embedded devices in an industrial environment. IoT system collects, process, and communicate real-time data to the cloud systems or any other database. Ultimately, intelligent monitoring of machine health, processes, predictive maintenance, fault-tolerant production system give the customized production and smart value chain. [36].

The generic architecture of integrated IoT has been proposed by [36]. The information & communication technologies including allied exponential technologies like data analytics, intelligent robotics are enabler to enhance the efficiency and flexibility of manufacturing system [37]. The communication technologies available for IoT connectivity are depended on the coverage area. Depending on the required range these communication technologies like proximity, Wireless Personal Area Network (WPAN), Wireless Local Area Network (WLAN), Lower-Power Wide Area Network (LPWAN) and Cellular standards are available. The technologies correspond to Proximity, WPAN, WLAN, LPWAN and cellular standards are RFID, Blue-tooth, Wi-Fi, LoRa and 5G, respectively [38]. The rapid personalization of the production line includes not only geometry and functional configuration, but also dynamic adaptability of the

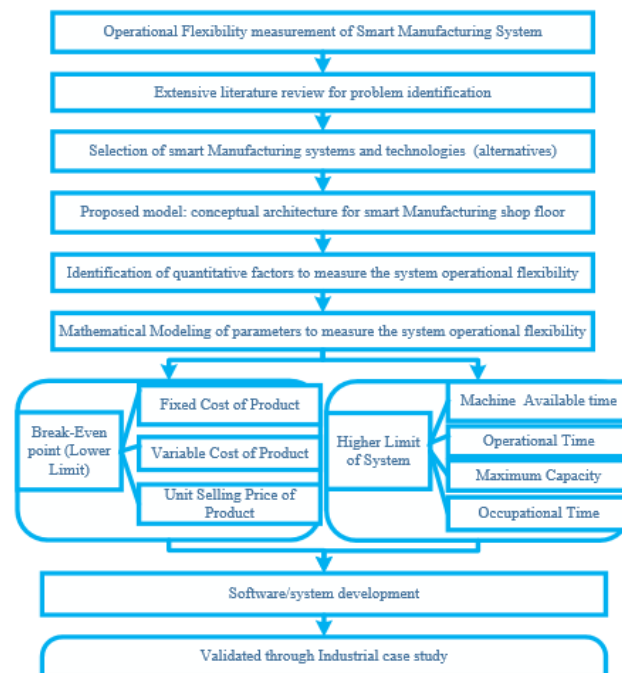

FIGURE 3. Steps involved in research methodology.

execution system. The improvement of the adaptive ability of the execution system depends strictly on the understanding of the key field problems, which requires the optimization of highly accurate mathematical modules and fast algorithms in the process of manufacturing execution [39].

The proposed model has communication options are Wi-Fi and 5G for interconnectivity of machines on shop floor and enterprise facilities integration, respectively.

III. RESEARCH METHODOLOGY

The methodology adopted for this research as shown in Figure 3, is composed of problem identification from extensive literature review. The literature review has been conducted from all major databases e.g Google scholar, Web of Science and Scopus etc. The keywords used are smart manufacturing, Industry 4.0, Cyber Physical Production System, additive manufacturing, industrial robots, 5G and operational flexibility. After conducting literature review, and conceptual architecture of CPPS enabled smart manufacturing shop floor has been proposed. In next phase the operational flexibility of measurement process has been explained and developed the quantitative method to measure for four manufacturing alternatives (CNC machining, flexible CNC machining autonomous robotic CNC machining and additive manufacturing/direct metal laser sintering machine). Last phase is related to the validation of developed system by industrial case study.

A. PROPOSE MODEL

Rationale behind the adoption of industry 4.0 technologies or transformation from conventional production system is quality, on-time production, reliability, cost reduction, waste

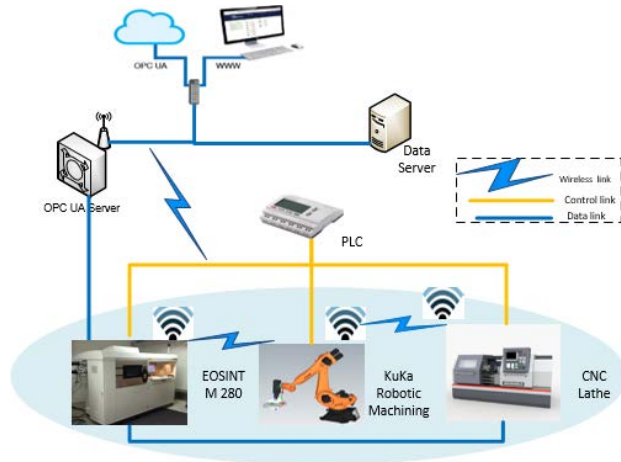

FIGURE 4. CPPS integration at shop floor with OPC UA.

reduction, and fast processing at the workplace to enhance productivity. In view of many authors that industry 4.0 enabled smart manufacturing poses many characteristics like flexibility [40]. The operational flexibility measurement model is enabling the various decision architecture models. Broadly, there are three main decision architectures are under consideration in literature. These are holistic optimization in integrated way, decentralized self-organizing way and hybrid models. In holistic way, digital twin-oriented optimization is used and its algorithms have two characteristics: 1) Quickly identify the best or near-optimized solutions in a short period of time to meet the highly frequent dynamic adjustment requirements of production systems and random delivery needs: 2) coordinate multiple objectives of coupling optimization issues [41]. Second way is decentralized self-organizing approach in manufacturing chain using blockchain-driven smart contracts in the social manufacturing of product architecture products. Blockchain is a tamper-proof, decentralized database that can be updated over time to avoid vulnerabilities when centralized nodes establish trust between manufacturers [42]. Third approach is hybrid model to deal with current need for a high degree of flexibility in manufacturing processes requires large-scale deployment of the Industrial Internet of Things (IIoT). Because centralized control of the Internet of Things lacks flexibility in dealing with disruption and change, a decentralized organizational structure is a better choice, with blockchain-driven licensing enabling partially decentralized self-organization to offload and accelerate optimization of high-level manufacturing planning. A new iterative, two-stage hybrid intelligence model called ManuChain is proposed to eliminate imbalances/inconsistencies between overall planning and local execution in personalized manufacturing systems [43].

In current study the hybrid model has been proposed for a smart and CPPS integrated shop floor with a communication system as shown in Figure 4. This model provides

the integration of physical world with cyber world through RAN (Radio Access Network)/ Air interface. In this paper, a smart system at the shop floor level has been introduced like CNC Machining, KuKa Robotic machining and EOSINT M 280 additive manufacturing smart machines. To show the impact of these sophisticated and intelligent machines on the operational flexibility.

Flexibility measurement is an important task to design the system and to guide the management regarding decision making that the adoption of new manufacturing technologies will benefit the factory or other wise. At shop floor level operational flexibility has been measured in the past but for smart manufacturing systems, it has not been measured yet. This system is composed of three main dimension views: physical world, Air interface and cyber world. To extend this concept partial modification has been made: make that architecture more specific for practical implementation. The data exchange and communication architecture of CPPS, 5G, and OPC UA (Open Platform Communication Unified Architecture) enabled system is shown in Figure 5. This is a detail depiction of system integration from physical events to result oriented information extraction and processing. The edge devices collecting sensors/actuators data of machines/assets in real-time and transmit to the industrial internet of things (IIoT) gateway. All the sensors/actuators or physical assets are connected to the edge devices through MQTT (Message Queuing Telemetry Transport) protocol. The IIoT gateway pushes the real-time data in the cloud infrastructure. The cloud infrastructure having high power computation for advance data analytics, storage facility and smart factor virtualization. The cloud transmit the control data to handle the machine functionality through programmable logic control (PLC). The Siemens S7 1500 PLC equipment has been proposed for this model. The PLCs are communicating through wireless and Ethernet channels. The International Electrotechnical Commission (IEC) standards are followed for communication between various devices. The IEC 61131 are followed for PLC programming and IEC 61784 for PLC communication through fieldbus. For machine to machine communication IEC 62541 standard been followed. The OPC UA (Open Platform Communication Unified Architecture) protocol has been recommended for communication between PLC and Cloud infrastructure. The PLC is connected to input/output(I/O) interfaces CNC, Robotic Machining (KUKA) and additive manufacturing machine (DMLS) through Profibus. The HMI provides the access to solution for management of facility on industrial scale.

In air interface reliable communication between distance unit (shop floor/factory) and central control has established through 5G microwave antennas. In bound reliable communication also be performed using 5G low power antennas and access points. The 5G infrastructure has reliable data transmission capability in real-time. The base station transverse (BTS) communicate with all the field devices in the designed geographical region.

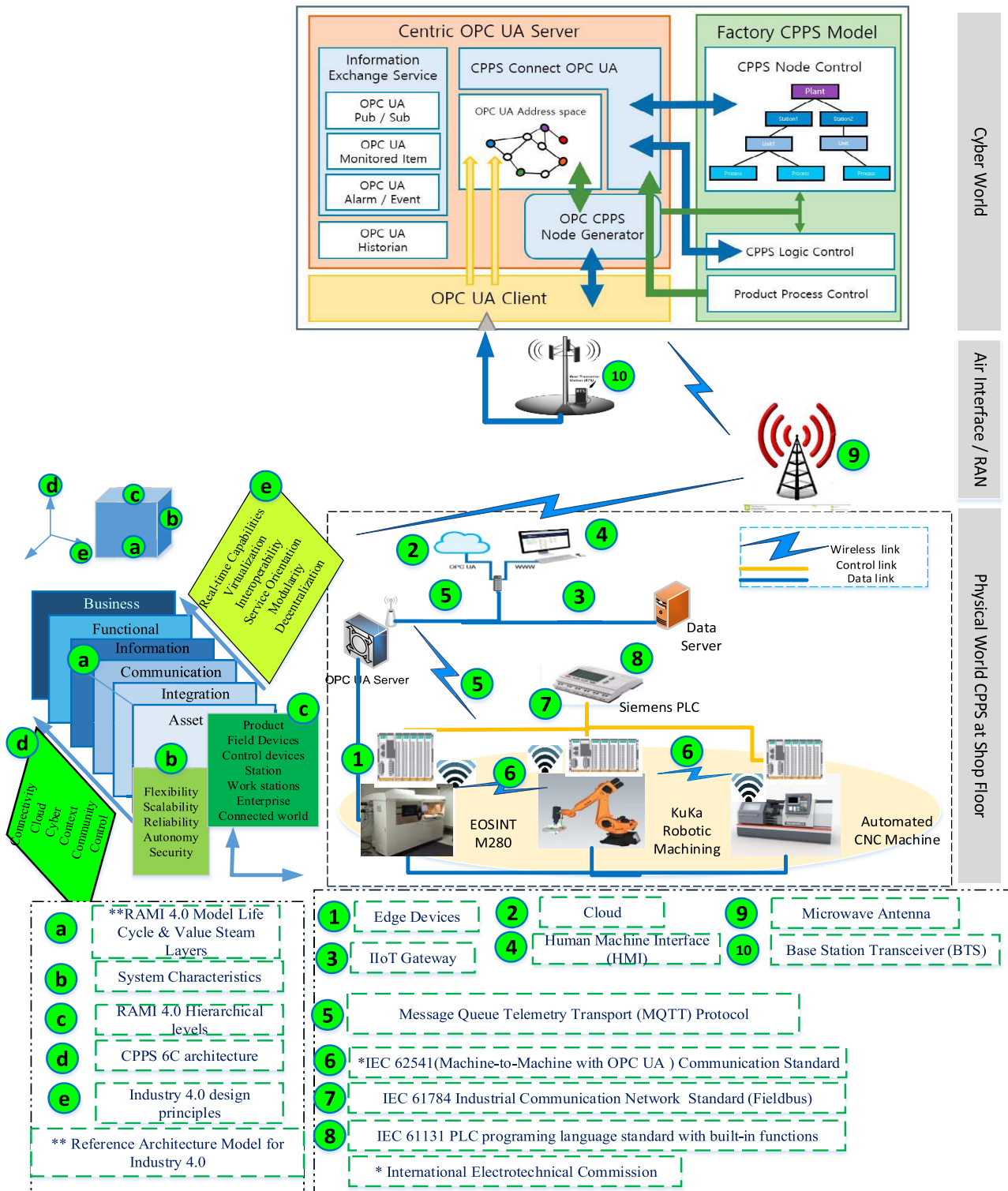

FIGURE 5. Data exchange and communication architecture of CPPS shop floor enabled with 5G and OPC UA (source: author's self creation except cyber word adopted from [44]).

OPC is an interoperability standard for safe and reliable data exchange in the field of industrial automation and other industries. It is platform-independent and ensures the seam-

less flow of information between devices from multiple vendors. In Cyber space the virtually two main modules of OPC UA are the factory CPPS model and OPC UA server. The

virtual CPPS factory model is composed of three important control systems which are CPPS node control, CPPS logic control and product process control. The control systems are integrated with the CPPS connect OPC UA for transmit the control instructions. The OPC UA has three main categories; Information exchange server, CPPS node generator and CPPS connect OPC UA. The information exchange server serve the purpose of asynchronous data transmission, monitoring mechanism, alarm generation and record all information updated in the address space. The recording method can be through choose relational database, NoSQL database, XML, binary file, etc. The connect CPPS OPC UA module update and change all data that occurs in the OPC UA address space and data used to communicate with CPPS node control, CPPS logic control and product process control. OPC CPPS node generator: automatic modeling generate attributes and codes required for CPPS node control, CPPS logic control and product processes control, register in OPC UA address space and OPC UA client in the factory CPPS model.

1) HARDWARE PLATFORM

traditional PC hardware, cloud server, PLC, microcontroller (ARM, etc.). *Operating system:*

Microsoft Windows, Apple OSX, Android or any Linux distribution, etc.

The OPC UA provides the necessary infrastructure for the interoperability of the entire enterprise, from machine to machine, machine to enterprise, and everything in between.

The OPC UA information modeling framework transforms data into information. With complete object-oriented functions, even the most complex multi-level structure can be modeled and extended. The modeling framework is the basic element of the OPC unified architecture. It defines the rules and basic building blocks required to use the OPC UA public information model. Although OPC UA has defined several core models that can be applied to many industries, other organizations build models on these models and disclose more specific information through OPC UA.

For client-server communication, access to a full range of information models can be obtained through services. This follows the service-oriented architecture (SOA) design paradigm through which service providers receive requests, process them, and send the results back to responses. Publish-Subscribe (PubSub) provides an alternative mechanism for data and event notification. Although in client-server communication, each notification is for a single client and guaranteed delivery, PubSub has been optimized for many-to-many configurations. With PubSub, OPC UA applications do not directly exchange requests and responses. Instead, the publisher sends the message to the message-oriented middleware without knowing which subscribers (if any) may be. Similarly, the subscriber expresses an interest in a particular type of data and processes messages containing this data without knowing its source.

CPPS is the integration and interconnection of multiple embedded devices through IoT network in real-time. IoT and

cloud are bridge between physical cyber communications, provides the ubiquitous connectivity. The IoT- loud architecture. Cloud communicate and process data using multiple protocols like MQTT. Message Queue Telemetry Transport (MQTT) proposed in this model, is one of most secure fast and energy efficient protocol used for data transmission in IoT systems and devices [45].

It is evident that from almost all definitions of smartness or digitization available in literature. The emergence of high computing, communication technologies and IoT integration has transform the industrial systems into industrial automation. This wireless connectivity and communication enabled industrial systems have real time capability of prognosis and diagnosis of problem to sustain the system functionality [46]. The wireless systems for data communication are vital. These systems have features of scalability, flexibility, less implementation cost and mobility. 5G communication and computing capabilities provides tremendous facility of real-time data analytics by using computational intensive processes. The ultimate target of smart embedded devices in IoT environment is to provide the real time integration, intercommunication, and interconnection between physical and cyber world.

In this study, the operational flexibility index will be developed for the smart shop floor, and later measurement pertaining to operational flexibility been evaluated. This evaluation will be a guideline for the decision maker, to transform conventional machining to smart machining systems. The smart manufacturing is more suitable to develop new business models in the competitive market. Flexibility is important feature of both lean manufacturing and IoT enabled smart manufacturing. The contribution of [17] is to define operational flexibility that combines the volume and mix flexibility of manufacturing system which proved that has connection with flexible manufacturing. For quantify, organizational versatility described both volume and mix flexibility as an integrated metric. Those constraints will be specific, hence the degree of organizational versatility, even with the same production method for each component together. Because of a mix of goods to be produced over a planned duration, organizational efficiency has extreme limits like lower and higher.

- Lower limit corresponds to break-even point would assess minimum potential of production network, determined by the quantity of products.

- Higher limit corresponds to the overall output of the manufacturing method shall be calculated by the volume of input provided.

- Break-even point: to measure the break-even point in the planned duration implies that the point of production (unit produced) where total production cost equals/meets the revenue. This is expressed in equation (2), where:

$$BEP_{LL} = \frac{\sum FC}{\sum_{i=1}^N w_i x (SP_i - VC_i)} \quad (2)$$

BEP_{LL}: Break-even point corresponds to lower limit of production in scheduled timespan.

FC: Fixed costs incurred.

V_{ci}: Variable cost associated to *i* product.

SP_{*i*}: Per unit selling price of product *i*.

w_{*i*}: Proportion in % of product *i*.

a: AVAILABLE TIME OF MACHINE

It is a time for which machine *j* is available for product *i*. Mathematical expressed in equation (3), The difference between total time machine *j* is on and maintenance time of machine *j* where:

$$Avt_j = Tton_j - Mt_j \tag{3}$$

Avt_{*j*}: Time available time to machine *j*, Tton_{*j*} is time (total) for which machine is in running state, Mt_{*j*} is time corresponds to maintenance of machine *j*.

j) OPERATIONAL TIME

It is the time consideration of operation on product *I* which include operating machine time and the setup machine time, calculation of this is shown in equation (4) where: Op_{*tj*} representing time a machine *j* operate, Q_{*j*} means in scheduled production time a machine *j* can produced maximum number of products, T_{*ij*}, is the processing time of machine *j* for product *i*, T_{*sij*} = setup time of machine *j* to process product *i*,

$$Op_{tj} = \sum_1^n (w_i \times T_{ij} \times Q_j + T_{sij}) \tag{4}$$

b: MAXIMUM CAPACITY

The maximum capacity of each machine will be attained when the available time of the machine is equal to it operational time of this machine using equations (5, 6, 7)

$$Op_{tj} = A_{tj} \tag{5}$$

$$Q_j = \frac{A_{tj} - \sum_1^n TS_{ij}}{\sum_1^n (w_i \times T_{ij})} \tag{6}$$

$$Q_{HL} = \min(Q_j) \tag{7}$$

c: OPERATIONAL FLEXIBILITY

The operational flexibility (OF) can be calculated as the difference between the highest limit and the lowest limit (8).

$$OF = Q_{HL} - Q_{LL} \tag{8}$$

B. COST ESTIMATION AND ECONOMIC ANALYSIS

In this section economic analysis of various manufacturing processes has been evaluated. At job shop or shop floor level smart manufacturing encouraging the additive manufacturing, robotic CNC machining and CNC machining. To perform the economic analysis of these processes, cost estimation and measurement of real-time systems will be evaluated.

1) COST ESTIMATION OF ADDITIVE MANUFACTURING PROCESS

In this case, the cost estimation model has been adopted from [47], which is suitable for heavy production process like additive manufacturing and more specifically Direct Metal Laser Sintering (DMLS). This model is based on activity-based cost modeling as contrary to the conventional method which is mostly the arithmetic sum of the direct and indirect cost of raw material. The mathematical expression of the total cost of the build is:

$$C_{build} = (C_{indirect} \cdot T_{build}) + (w \cdot Price_{material}) + (E_{build} \cdot Price_{energy}) \tag{9}$$

Byun and Lee have introduced a mathematical model in which time to build and surface roughness is considered to calculate the optimum part orientation [48]. This correlation of time to build with geometric parameters like cross-section area, length, height representing the part orientation to be built. Mathematically, this relation of time to build and parameters under consideration has been shown in Equation 10 [48].

$$T_{build} = N \left(T_p + dp \left(\frac{\bar{A}_p}{A_{phr}} + \frac{\bar{A}_p}{A_{psr}} \right) \right) + ds \frac{\bar{A}}{Asr} \tag{10}$$

$$\bar{A}_s = S_A d_d / N \cdot l_t \tag{11}$$

$$\bar{A}_p = v_p / N \cdot l_t \tag{12}$$

Part Cross sectional area (average) [mm²].

ld: Diameter of laser beam spot [mm].

A_{psr}: Area irate scanning the interior of the part [mm²/s] *l_t*: Thickness of layer [mm] *A_{phr}*: Area irate hatching the interior of the part [mm²/s] *m_{material}*: Material mass[kg] *A_s*: Average cross section area of support [mm²] *N*: Number of layers *Asr*: Area rate scanning the support [mm²/s] *C_{build}*: Cost of build [\$] *P_{riceenergy}*: Energy consumed price [\$/ J], *dp*: Part density [kg/m³] *P_{ricematerial}*: Material price [\$/ kg], *VP*: Process velocity [mm³/s] *C_{indirect}*: Costs related to machines [\$/ h] *SA*: Surface area of part [m²].

C_{material}: Material Cost used in [\$/ kg] *T_{Build}*: Total build time [h] *T_p*: layer to layer idle time/period [s], *w*: Mass of the piece [kg], *ds*: Supporting Structure Density [kg/m³] *E_{build}*: Energy consumption to build[J].

a: ENERGY COST OF SYSTEMS

Total energy investment, *E_{Build}*, can be modeled. However, a purely time-dependent element of power consumption must be expected in the continuous operation of the AM machine. Equation (13) can be use to total energy investment.

$$E_{build} = E_{job} + (E_{time} \times T_{build}) + (E_{layer} \cdot xl) + \sum_{z=1}^z \sum_{y=1}^y \sum_{x=1}^x E_{voxelxyz} \tag{13}$$

$$E_{additive} = \sum_{n=N} \frac{0.001(W)(t_{warmup})}{3600}$$

$$+ \frac{0.001(W)(t_{Runtime})}{3600} \quad (14)$$

$$Cost = Cost_{tool_path_generation} + C_{machining} + C_{Tool} + C_{setup} + C_{material} + C_{overhead} \quad (15)$$

$$C_{machining} = Machining_Time * (MachineCost/Hr + LaborCost/Hr) \quad (16)$$

Total energy investment, E_{Build} , can be modeled. It is time-dependent system and power consumption required to operate the additive manufacturing machine. Mathematically power or energy consumption is the product of time to build T_{Build} and energy consumption rate \dot{E}_{Time} . To model the energy rate \dot{E}_{Time} , means energy consumption during the additive manufacturing process by the machine. This energy has been consumed by the machine components which continued in operation to complete the processing. These components are the control system, heating system, cooling fan, and pumps. [47]. In the above equation, E shows the energy consumption of the system in kilowatts if the w weight of part in kilograms for t time of processing, and total parts produced N in a run [49]. In the above equation, E shows the energy consumption of the system in kilowatts if the w weight of part in kilograms for t time of processing, and total parts produced N in a run [49].

2) COST ESTIMATION OF CNC AND ROBOTIC MACHINING PROCESSES

In CNC machining the complete job is combination of generation of tool path, machining processing, replacement of tool, and setup activities. In the same way, the cost involved in complete CNC machining is the summation of all costs of these activities. Mathematically, equation (15) used to calculate the total cost of CNC machining job. $C_{Tool-Path-Generation}$: Cost associated to the tool path generation. It is product of time to design the tool path generation and salary of programmer.

To simplify the process and use existing CAD (Computer Aided Design)/CAM (Computer Aided Manufacturing) software, after the user generates CNC tool route, the machining time is read directly from CAM software. All operations can be performed in plain text format by most CAM applications. This performance includes tool time for cutting, total machine time, and process parameters for cutting. The difference between the time of the tool cutting and the overall time of the machine is the change of tool and the time of engagement. The tool change and cost of engagement is included in the overall cost of the machining in this job. Computer funding is translated to the expense of the system per hour which is used in the expense of measuring the capital spending on the CNC.

$$MachineCost/Hr = Machine_Purchase_Cost / (Yearsof Return * Average_work_hours/year)$$

Machine-Purchase-Cost: CNC machine purchasing cost. Years-Of-Return: machine ROI (Return on Investment) will pay off. Average-Work-Hours-Per-Year, Labour-Cost-Per-

Hour.

$$C_{il} = \sum_{i=1}^n (TL_i \times C_{TPi}) \quad i = 1, 2, \dots, n \quad (17)$$

where i represents the No. of tools used, TL_i represents the tool life in use of tool i and C_{TPi} is purchasing cost of tool i.

In order to calculate tool life T aylor's formula (equation 18) with operation has been used.

$$VxT^n = C \quad (18)$$

where V is the cutting speed in ft. /min. i T is the tool life in minutes. i in is a constant based on the tool material. i C is a constant based on the tool material, work piece material and the cutting condition. C can be obtained from manufacturer's manual or determined experimentally. With this information, tool life can be calculated for any given cutting speed. A tool may be used several times in the machining. The used tool life for a tool can be calculated as following

$$TL_i = \sum_{j=1}^n \left(\frac{T_{ut}}{T_{lj}} \right) \quad (19)$$

where TL_i is tool life during in use of tool i and expressed as a decimal fraction. It provides the information when tool will be replaced. For example, if its value equal to or greater than one, then tool replacement will due. No. of i operations are represented by in of tool i; j is the index of operations of tool i. T_{utj} is the tool usage time of operation j for tool i. T_{lj} is the tool life at the cutting speed of operation j for tool i. C_{setup} is the total cost associated to work piece location and clamping. $C_{material}$ is the product of work piece volume and the material cost per unit volume. $C_{overhead}$ is for all other costs that machining involves but not listed above such as management, rent, electricity, etc. In this work, the fixture component inventory is included in the overhead; the setup operation cost and custom-made fixture cost are included in the setup cost as shown in equation (20).

$$C_{setup} = \sum (N_{SCO} \times C_{SCO} + N_{TCO} \times C_{TCO} + N_{CSO} \times C_{CSO} + N_{MSO} \times C_{MSO} + N_{SSO} \times C_{SSO} + T_{AL} \times C_{ULC} + C_{pfso} + C_{pfmc} + C_{sfso} + C_{sfmc}) \quad (20)$$

C_{setup} = Setup-Cost, N_{SCO} = No. of side-clamping-operations, C_{SCO} = Cost per side-clamping-operation, N_{TCO} = No. of Top-Clamping-Operations, C_{TCO} = Cost Per Top-Clamping-Operation N_{CSO} = No. of Complex-Supportive-Operations, C_{CSO} = Cost per Complex-Support-Add-Operation, N_{MSO} = No. of Medium-Supportive-Operations, C_{MSO} = Cost per Medium-Support-Add-Operation, N_{SSO} = No. of Simple-Supportive-Operations, C_{SSO} = Cost per Simple-Support-Add-Operation, T_{AT} = Alignment-Time, C_{ULC} = Unit Labor-Cost, C_{pfso} = Cost of Pin-Fixture-Setup-Operation, C_{pfmc} = Pin-Fixture-Manufacturing-Cost, C_{sfso} = Cost of Special-Fixture-Setup-Operation, C_{sfmc} = Special-Fixture-Manufacturing-Cost.

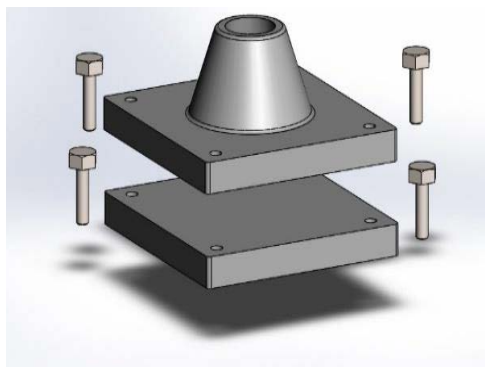

FIGURE 6. 3D view of burner nozzle assembly.

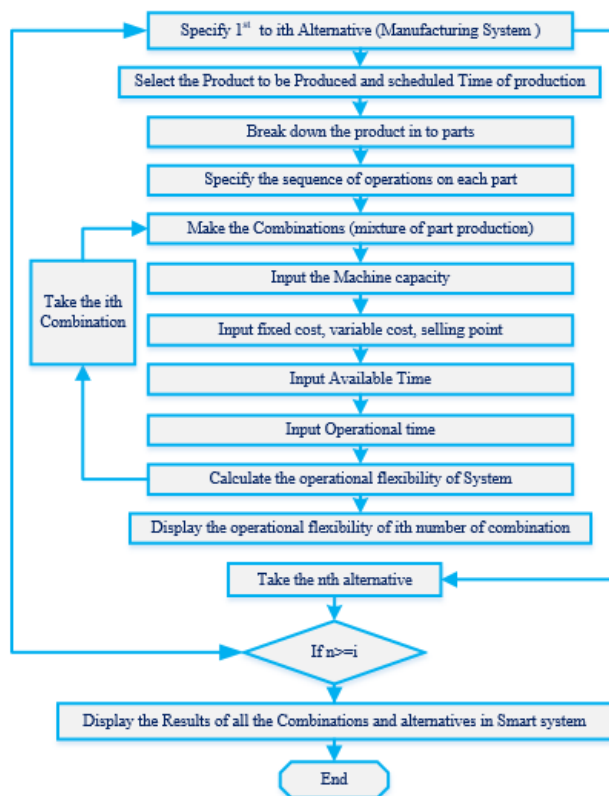

FIGURE 7. Scheme of system scenario.

IV. INDUSTRIAL CASE STUDY

The case study selected for this research is the manufacturing of product called burner nozzle assembly as shown in Figure 6. It is an important component in boiler of sugar mills plant and the cost relationship between AM, CNC machining and robotic machining to measure the operational flexibility of these processes.

The steps involved in the case study system scenario are formulated in Figure 7.

In this empirical research, five combinations have been considered for scheduled period of production. The combinations are shown in Table 1. Combination A: No mixture

TABLE 1. Five combinations of production scheme.

Product/Part	*Comb o-A	*Comb o-B	*Comb o-C	*Combo-D	*Combo-E
Base Plate	100	0	25	35	15
Burner Nozzle	0	100	25	35	15
Bolts	0	0	25	15	35
Nuts 4	0	0	25	15	35

*Combo=Combinations

TABLE 2. Product, operation and sequence of CNC machine.

Product	Sequence	Operation	Task	Automated CNC Machining
Base Plate	1	Milling	Thickness Reduction	CNC miller
	2	Drilling	Four holes	CNC lathe
	3	Drilling	Central hole	CNC lathe
	4	Boring	Central hole	CNC lathe
	5	Threading	Four holes	CNC lathe
Burner Nozzle	1	Taper Turning	Nozzle	CNC miller
	2	Drilling	Four holes	CNC lathe
	3	Boring	Four holes	CNC lathe
	4	Drilling	Four holes	CNC lathe
	5	Threading	Four holes	CNC lathe
Bolt	1	Turning	Neck	CNC lathe
	2	Threading	Neck	CNC lathe
	3	Filing	Head	Automatic
Nut 4	1	Drilling	Holes	CNC lathe
	2	Boring	Holes	CNC lathe
	3	Threading	Holes	CNC lathe
	4	Filing	-	Automatic

of part operations, only base plate manufactured as per process 1. Combination B: No mixture of part operations, only bolts and Nuts 4 fabricated as per process 2. Combination C: All parts are fabricated with same percentage, balanced operations. Combination D: with mix production, predominance to part 1. Combination E: with mix production, predominance to part 2.

Simulation has been done using four alternatives.

Alternative 1: Operations performed through automated CNC machining with less flexibility, Alternative 2: Operations performed through CNC machining and robotic machining with more flexibility, Alternative 3: manufacturing using CPPS enabled robotic CNC and additive manufacturing and Alternative 4: Fabrication using Smart Additive Manufacturing (DMLS).

In case of additive manufacturing, the operations treatment on the part/product is bypassed. Only CAD file has been made to fit the desired combination of parts on the tray. The desired geometry will automatically be formed during laser metal sintering process.

V. RESULTS AND DISCUSSION

A computer software has been developed to perform the simulations and show the interactive results. The development detail of software is not included in this paper, it's only

TABLE 3. Operation and sequence of robotic CNC machine.

Product	Sequence	Operation	Task	Robotic CNC Machining
Base Plate	1	Milling	Thickness Reduction	Robotic CNC Milling
	2	Drilling	Four holes	Robotic CNC Driller
	3	Drilling	Central hole	Robotic CNC Driller
	4	Boring	Central hole	Robotic CNC Driller
	5	Threading	Four holes	Robotic CNC Driller
Burner Nozzle	1	Taper Turning	Nozzle	Robotic CNC Miller
	2	Drilling	Four holes	Robotic CNC Driller
	3	Boring	Four holes	Robotic CNC Driller
	4	Drilling	Four holes	Robotic CNC Driller
	5	Threading	Four holes	Robotic CNC Miller
Bolt	1	Turning	Neck	Robotic CNC Miller
	2	Threading	Neck	Robotic CNC Miller
	3	Filing	Head	Robotic Arm
Nut	1	Drilling	Holes	Robotic CNC Miller
	2	Boring	Holes	Robotic CNC Miller
	3	Threading	Holes	Robotic CNC Miller
	4	Filing	-	Robotic Arm

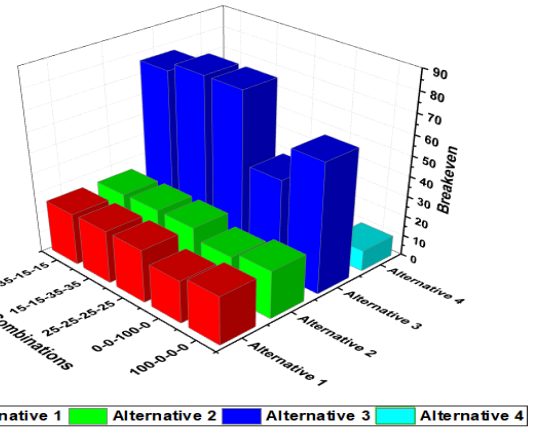

FIGURE 10. Breakeven trend of alternatives [1, 2, 3, 4].

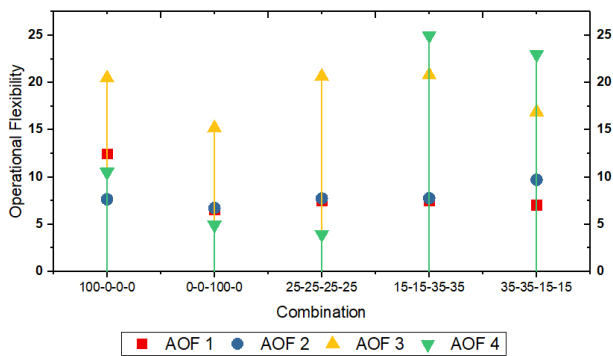

FIGURE 8. Operational flexibility alternatives [1, 2, 3, 4].

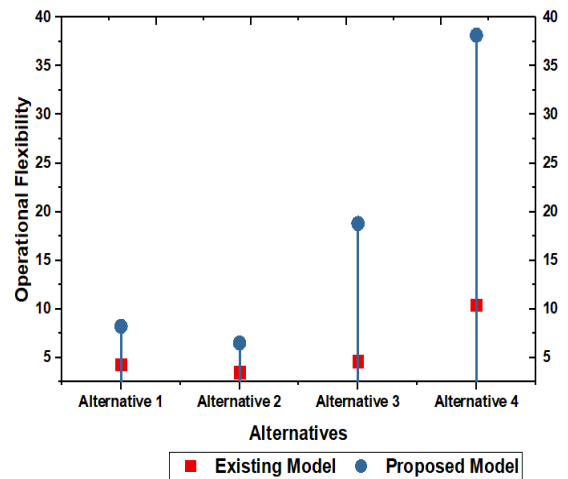

FIGURE 11. Comparison of proposed model with existing model.

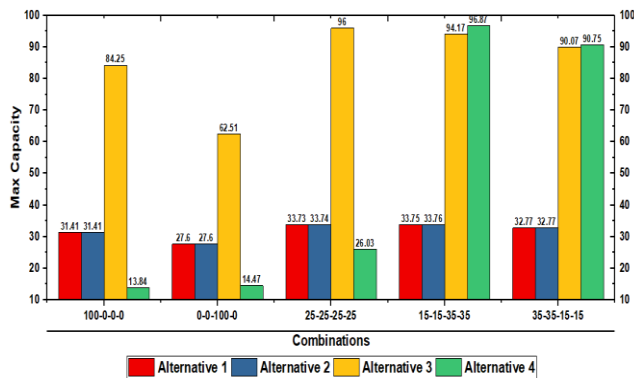

FIGURE 9. Max Capacity trends alternatives [1, 2, 3, 4].

focused on the interpretation of results and its implications. The results achieved are displayed in Figure 12 (alternative-1), Figure 13. (alternative- 2), Figure 14. (alternative-3) and Figure (Alternative-4).

It is clear from these graphs, the highest limit, the lowest limit, and the operational flexibility, for each combination of products. Classical architecture and design of manufacturing machines are introduced in alternative 1 and 2.

It is clear from graphs in Figure 10 and Figure that operational flexibility values for alternative 1 and 2 are comparatively smaller. In comparison with alternative 1, the alternative 2 has larger value of operational flexibility. Modern architecture and design of smart manufacturing machines are introduced in alternative 3 and 4. It is clear from graphs in Figure 14 and Figure 15 that operational flexibility values for alternative 3 and 4 are bigger. And same is case with the maximum capacity of these two alternatives. The reason of elevation of operational flexibility and maximum capacity is due to reduction in processing machine times and products shift and machine-to-machine transportation time, when smart and flexible system has been introduced.

For instance, Robotic machining has capability of self-controlled autonomous operations with optimized motion of axis and tool, this provides the advantage of reduction in Operation and transportation costs. The breakeven point (lower-limit) of alternative 2, 3 and 4 has exponential trend as machines are expensive and machinery amortization cost increased despite of less production cost as less labor required for these systems machines, increase the operational

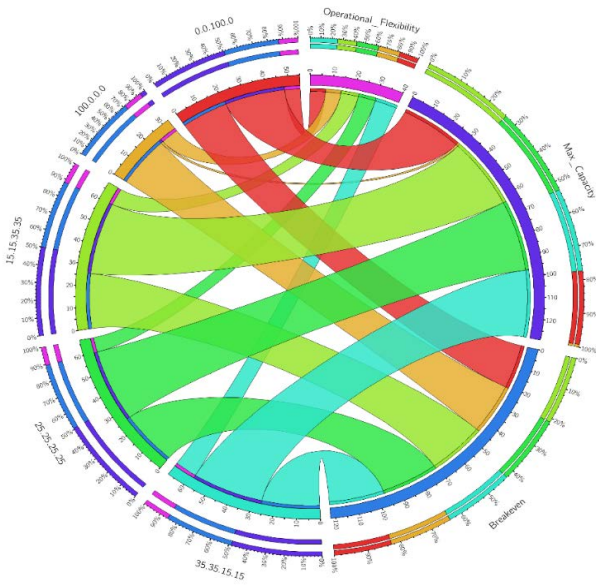

FIGURE 12. Alternative 1 Smart CNC machining.

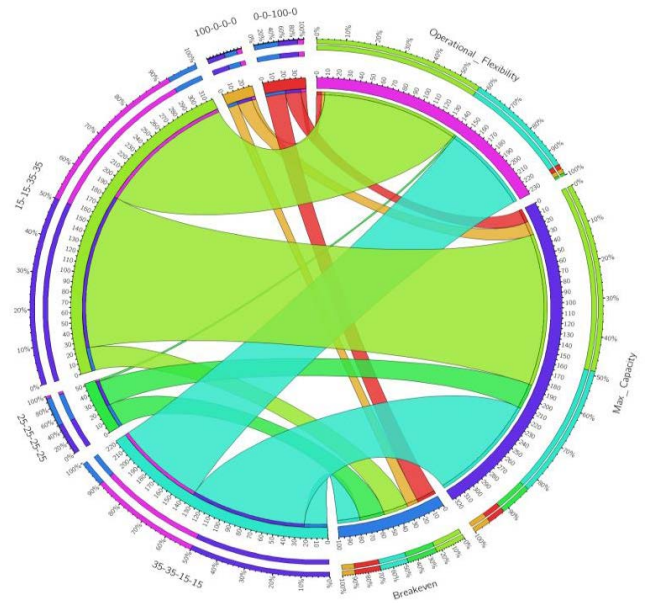

FIGURE 14. Alternative 3, smart additive manufacturing.

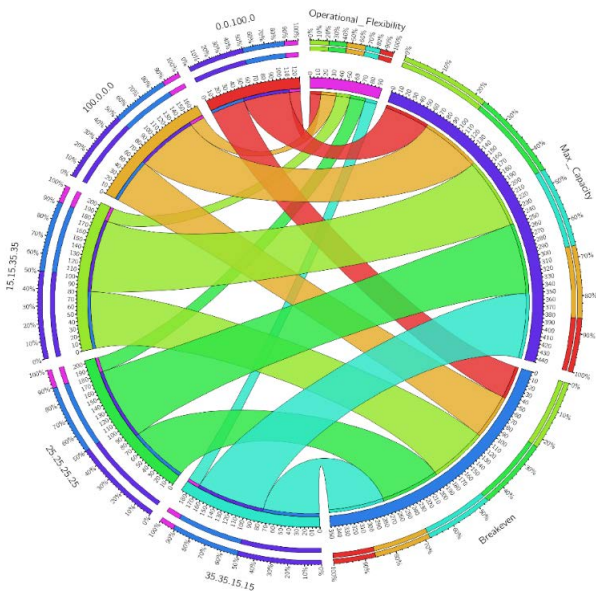

FIGURE 13. Alternative 2, smart robotic CNC.

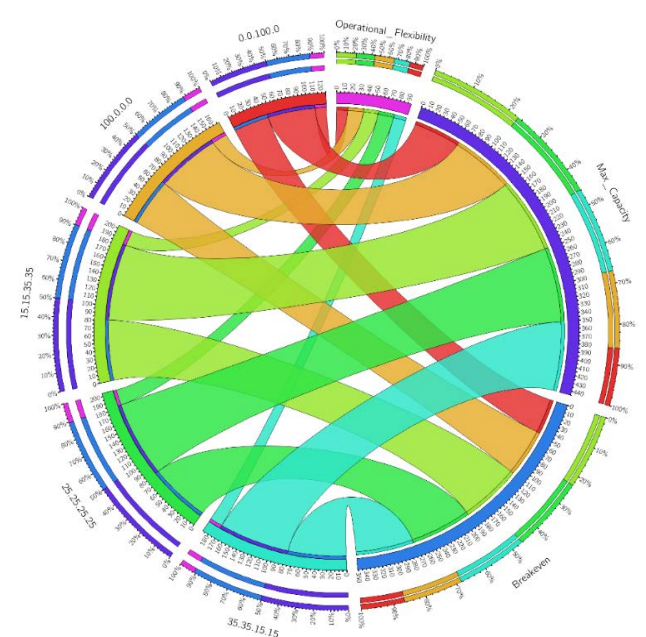

FIGURE 15. Alternative 4, smart hybrid additive and subtractive manufacturing.

flexibility of smart manufacturing systems. On the other hand. Alternative 1 representing the manufacturing machines with lesser flexibility and limited smart system compatibility. In Figure 8 it is clear that the operational flexibility value is bigger in case of Alternative 4. Alternative 4 corresponds to the IoT enabled CPPS and smart machines. So, it is evident that introduction of IoT enabled CPPS (smart systems) in manufacturing system enhance the operational capabilities of system. Higher value of operational flexibility in a system represents its capability and capacity to increase the productivity. And accommodate the changing demand of product mix and volume by the customer at operational level.

This property of smart system provides the competitive advantage and on time delivery to customer. It represents the comparatively rigid and without functional flexibility system. Alternative 2 has same machine with functional flexibility. Alternative 3 comprised of smarter and autonomous manufacturing systems. Alternative 3 represents the robotic machining system integrated with self-controlled and self-drive CPPS. This system provides the more functional flexibility. In alternative 4 additive manufacturing system (3D printer, Direct Metal Laser Sintering) has been introduced.

The operational flexibility shown growing trend for alternative 3 and alternative 4. It is shown in Figure 9, that maximum capacity of alternative 1 and 2 have same values because both using same type of machines.

So, the highest limit in both cases will be remained same. Alternative 3 and 4 shown variations in highest limit as system composed of two different types of smart manufacturing machines.

Alternative 3 which represent the robotic machining has shown consistent trend pertaining maximum capacity irrespective of combination of product operations. Alternative 4 shown maximum value of highest limit for specific combination of products. If the product size mixed with smaller product in size, the maximum capacity can be attained by using additive manufacturing. The breakeven trend of alternative 3 is higher as compared to alternative 1 and 2. First and second Alternatives has lesser lower limit because the cost of machines and labor cost are lesser in scheduled production time. The operational flexibility of proposed system is much improved than the existing one as shown in Figure 11. The design and architecture of industrial internet of things enabled cyber-physical production system provides more operational flexibility. The property of system architecture give decision makers ease to transform the system and introduction smart capabilities.

VI. CONCLUSION

A. OBJECTIVE ACHIEVED

The results obtained from the proposed model has revealed that the objective of measuring operational flexibility for smart systems has been achieved. The new conceptual architecture model of CPPS enabled shop floor has been validated using the novel mathematical modeling scheme of operational flexibility measurement. The break-even point for smart system adoption has been enhanced and same is the case for maximum capacity of machines. Ultimately, the improvement in operational flexibility has been observed by enhancing these parameters using smart manufacturing technologies. The initial investment cost is much higher for implementation of hybrid manufacturing machines, on the other hand return of investment (ROI) period is manageable. The enhanced production capacity and ability to manage the customized production make it possible to reduce the ROI period. The proposed model will be more suitable option for decision makers and industrial experts to gauge the operational flexibility of smart systems at planning phase prior to make the high investment decision. It provides the way out, the challenges faced by the decision makers, consultants, and top management of manufacturing enterprises to introduce the smart technologies. On-time delivery performance through selective changes (smart technology selection) in the machines and functional flexibility to get the optimal level of operational flexibility. The major benefits of proposed model are; to provide the guideline before investment decision options to add the smart systems on the basis of operational

flexibility. Management can be facilitated about the decision to purchase the machines on the bases of operational flexibility. As management have to reduce the break-even point by introducing smart/more flexible systems. It will help to operationalization of human resource and machines in scheduled time for production. And from the system designer prospect it will helpful to give the clear understanding about smart technologies improve the operational flexibility up to certain level. It will be used to develop the characteristics based decision support system for industrial application. As the historical data stored in the cloud/data base is important to develop the demand driven production in schedule period. It will be helpful for management to develop the tool used for decision regarding modifications/changes.

B. FILLING THE GAP

previously, the model based operational flexibility measurement for smart manufacturing systems has not been carried out. Only one study pertain to measuring the operational flexibility has been conducted for conventional manufacturing systems. Current study filling the research gap by developing model based measurement of operational flexibility for smart manufacturing systems. The operational flexibility measurement of smart systems is relatively complex, complicated and computation intensive process. The innovative model has been developed to facilitate the decision makers for smart manufacturing transformation.

C. LIMITATIONS

The scope of this study is confined at CPPS enabled shop floor and consideration of relatively less complex production scenario due to certain limitations. To study the entire enterprise in all levels is cumbersome and complex process. To carry out current study, research is divided in to module and limited to CPPS at shop floor level. In industrial case study one product is selected to test and validate the system due limited access to the more complex smart production facility for real-time data collection.

D. FUTURE WORK

The future prospect of this study is to implement in complex enterprise environment like multiple shop floor, smart factory and plant level situated at various locations. The proposed model can be extended for the consideration of more complex enterprise operations. This model can be used to develop the decision support system to manage the smart industrial applications. This work can be extended to implementing for self-organizing model (Blockchain decentralized distributed process control) and hybrid approach (blockchian and industrial internet of things IIoT) decision architectures in smart manufacturing paradigm.

REFERENCES

- [1] D. Dikhanbayeva, S. Shaikholla, Z. Suleiman, and A. Turkyilmaz, "Assessment of industry 4.0 maturity models by design principles," *Sustainability*, vol. 12, no. 23, p. 9927, Nov. 2020.

- [2] H. Kühnle and G. Bitsch, *Foundations & Principles of Distributed Manufacturing*, vol. 422. Cham, Switzerland: Springer, 2015.
- [3] J. Park and J. Lee, "Presentation on Korea smart factory program," in *Proc. Int. Conf. Adv. Prod. Manage. Syst.*, Tokyo, Japan, 2015.
- [4] J. Davis, "Cyber infrastructure in chemical and biological process systems: Impact and directions," in *Proc. NSF Workshop Rep.*, Arlington, VA, USA, 2006.
- [5] H.-S. Park and N.-H. Tran, "Autonomy for smart manufacturing," *J. Korean Soc. Precis. Eng.*, vol. 31, no. 4, pp. 287–295, Apr. 2014.
- [6] J. Davis, "Smart process manufacturing: An operations and technology roadmap," Smart process manufacturing engineering virtual organization steering committee, Los Angeles, CA, USA, Tech. Rep., 2009.
- [7] R. Rathinasabapathy, M. J. Elsass, J. R. Josephson, and J. F. Davis, "A smart manufacturing methodology for real time chemical process diagnosis using causal link assessment," *AIChE J.*, vol. 62, no. 9, pp. 3420–3431, Sep. 2016.
- [8] D. Kibira, "Methods and tools for performance assurance of smart manufacturing systems," U.S. Dept. Commerce, Nat. Inst. Standards Technol., Gaithersburg, MD, USA, Tech. Rep., 2015.
- [9] M. P. Papazoglou, W.-J. van den Heuvel, and J. E. Mascolo, "A reference architecture and knowledge-based structures for smart manufacturing networks," *IEEE Softw.*, vol. 32, no. 3, pp. 61–69, May/June 2015.
- [10] Y. Lu, K. C. Morris, and S. Frechette, "Standards landscape and directions for smart manufacturing systems," in *Proc. IEEE Int. Conf. Automat. Sci. Eng. (CASE)*, Aug. 2015, pp. 998–1005.
- [11] A. Kusiak, "Smart manufacturing must embrace big data," *Nature*, vol. 544, no. 7648, pp. 23–25, 2017.
- [12] K. Cheng, "Keynote presentation—2: Smart tooling, smart machines and smart manufacturing: Working towards the industry 4.0 and beyond," in *Proc. 21st Int. Conf. Autom. Comput. (ICAC)*, Sep. 2015, p. 1.
- [13] A. De Toni and S. Tonchia, "Manufacturing flexibility: A literature review," *Int. J. Prod. Res.*, vol. 36, no. 6, pp. 1587–1617, Jun. 1998.
- [14] J. Browne, "Classification of flexible manufacturing systems," *FMS Mag.*, vol. 2, no. 2, pp. 114–117, 1984.
- [15] A. Sethi and S. Sethi, "Flexibility in manufacturing: A survey," *Int. J. Flexible Manuf. Syst.*, vol. 2, no. 4, pp. 289–328, Jul. 1990.
- [16] L. L. Koste and M. K. Malhotra, "A theoretical framework for analyzing the dimensions of manufacturing flexibility," *J. Oper. Manage.*, vol. 18, no. 1, pp. 75–93, Dec. 1999.
- [17] J. J. Peláez-Ibarrondo and J. Ruiz-Mercader, "Measuring operational flexibility," *Manuf. Inf. Syst.*, p. 292, May 2001.
- [18] A. Gilchrist, *Introducing Industry 4.0*, in *Industry 4.0*. Bangkok, Thailand: Springer, 2016, pp. 195–215.
- [19] S. Mittal, M. A. Khan, D. Romero, and T. Wuest, "Smart manufacturing: Characteristics, technologies and enabling factors," *Proc. Inst. Mech. Eng., B, J. Eng. Manuf.*, vol. 233, no. 5, pp. 1342–1361, 2017.
- [20] G. Adamson, "Cloud manufacturing—a critical review of recent development and future trends," *Int. J. Comput. Integr. Manuf.*, vol. 30, nos. 4–5, pp. 347–380, 2017.
- [21] S. El Hamdi and A. Abouabdellah, "Proposal of a general framework of smart factory," in *Proc. Int. Conf. Electr. Inf. Technol. (ICEIT)*, Mar. 2020, pp. 1–6.
- [22] F. Tao and Q. Qi, "New IT driven service-oriented smart manufacturing: Framework and characteristics," *IEEE Trans. Syst., Man, Cybern. Syst.*, vol. 49, no. 1, pp. 81–91, Jan. 2017.
- [23] L. Nicora, R. Ambrosetti, G. J. Wiens, and I. Fassi, "Human-robot collaboration in smart manufacturing: Robot reactive behavior intelligence," *J. Manuf. Sci. Eng.*, vol. 143, pp. 1–35, Mar. 2020.
- [24] A. Radziwon, "The smart factory: Exploring adaptive and flexible manufacturing solutions," *Proc. Eng.*, vol. 69, pp. 1184–1190, Jan. 2014.
- [25] A. A. Minhas, S. Jabbar, M. Farhan, and M. N. Ul Islam, "Smart methodology for safe life on roads with active drivers based on real-time risk and behavioral monitoring," *J. Ambient Intell. Hum. Comput.*, pp. 1–13, Nov. 2019.
- [26] T. Stock and G. Seliger, "Opportunities of sustainable manufacturing in industry 4.0," *Proc. CIRP*, vol. 40, pp. 536–541, Jan. 2016.
- [27] D. A. Rossit, F. Tohmé, and M. Frutos, "Production planning and scheduling in cyber-physical production systems: A review," *Int. J. Comput. Integr. Manuf.*, vol. 32, nos. 4–5, pp. 385–395, May 2019.
- [28] D. Mourtzis, N. Milas, and A. Vlachou, "An Internet of Things-based monitoring system for shop-floor control," *J. Comput. Inf. Sci. Eng.*, vol. 18, no. 2, Jun. 2018.
- [29] V. Alcácer and V. Cruz-Machado, "Scanning the industry 4.0: A literature review on technologies for manufacturing systems," *Eng. Sci. Technol., Int. J.*, vol. 22, no. 3, pp. 899–919, 2019.
- [30] A. Paul, A. Ahmad, M. M. Rathore, and S. Jabbar, "SmartBuddy: Defining human behaviors using big data analytics in social Internet of Things," *IEEE Wireless Commun.*, vol. 23, no. 5, pp. 68–74, May 2016.
- [31] P. Ba, S. Pn, and S. Pm "Shop floor to cloud connect for live monitoring the production data of CNC machines," *Int. J. Comput. Integr. Manuf.*, vol. 33, pp. 1–17, Feb. 2020.
- [32] L. Monostori, "Cyber-physical production systems: Roots, expectations and R&D challenges," *Proc. CIRP*, vol. 17, pp. 9–13, Jan. 2014.
- [33] H. Fatorachian and H. Kazemi, "A critical investigation of industry 4.0 in manufacturing: Theoretical operationalisation framework," *Prod. Planning Control*, vol. 29, no. 8, pp. 633–644, Jun. 2018.
- [34] J. Lee, B. Bagheri, and H.-A. Kao, "A cyber-physical systems architecture for industry 4.0-based manufacturing systems," *Manuf. Lett.*, vol. 3, pp. 18–23, Jan. 2015.
- [35] R. Y. Zhong, X. Xu, E. Klotz, and S. T. Newman, "Intelligent manufacturing in the context of industry 4.0: A review," *Engineering*, vol. 3, no. 5, pp. 616–630, 2017.
- [36] W. Z. Khan, M. H. Rehman, H. M. Zangoti, M. K. Afzal, N. Armi, and K. Salah, "Industrial Internet of Things: Recent advances, enabling technologies and open challenges," *Comput. Electr. Eng.*, vol. 81, Jan. 2020, Art. no. 106522.
- [37] K.-D. Thoben and S. T. W. Wuest, "Industrie 4.0," and smart manufacturing—A review of research issues and application examples," *Int. J. Automat. Technol.*, vol. 11, no. 1, pp. 4–16, 2017.
- [38] A. E. Hakim, "Internet of Things (IoT) system architecture and technologies," *Convergent Netw., Egypt, White Paper*, Mar. 2018, p. 5.
- [39] H. Zhang, Q. Liu, X. Chen, D. Zhang, and J. Leng, "A digital twin-based approach for designing and multi-objective optimization of hollow glass production line," *IEEE Access*, vol. 5, pp. 26901–26911, 2017.
- [40] O. L. De Weck, A. M. Ross, and D. H. Rhodes, "Investigating relationships and semantic sets amongst system lifecycle properties (ilities)," MIT-ESD, USA, Tech. Rep., 2012.
- [41] J. Leng, "Digital twin-driven joint optimisation of packing and storage assignment in large-scale automated high-rise warehouse product-service system," *Int. J. Comput. Integr. Manuf.*, vol. 34, pp. 1–18, Aug. 2019.
- [42] J. Leng, P. Jiang, K. Xu, Q. Liu, J. L. Zhao, Y. Bian, and R. Shi, "Makerchain: A blockchain with chemical signature for self-organizing process in social manufacturing," *J. Cleaner Prod.*, vol. 234, pp. 767–778, Oct. 2019.
- [43] J. Leng, D. Yan, Q. Liu, K. Xu, J. Zhao, R. Shi, L. Wei, D. Zhang, and X. Chen, "Manuchain: Combining permissioned blockchain with a holistic optimization model as bi-level intelligence for smart manufacturing," *IEEE Trans. Syst., Man, Cybern., Syst.*, vol. 50, no. 1, pp. 182–192, Jan. 2020.
- [44] J. Kim, G. Jo, and J. Jeong, "A novel CPPS architecture integrated with centralized OPC UA server for 5G-based smart manufacturing," *Proc. Comput. Sci.*, vol. 155, pp. 113–120, Jan. 2019.
- [45] M. M. Iqbal, "An enhanced framework for multimedia data: Green transmission and portrayal for smart traffic system," *Comput. Electr. Eng.*, vol. 67, pp. 291–308, Apr. 2018.
- [46] J.-P. Vasseur and A. Dunkels, *Interconnecting Smart Objects With IP: The Next Internet*. San Mateo, CA, USA: Morgan Kaufmann, 2010.
- [47] M. Baumers, "Combined build-time, energy consumption and cost estimation for direct metal laser sintering," in *Proc. 23rd Annu. Int. Solid Freeform Fabrication Symp. Additive Manuf. Conf.*, 2012, pp. 1–13.
- [48] H. S. Byun and K. H. Lee, "Determination of the optimal part orientation in layered manufacturing using a genetic algorithm," *Int. J. Prod. Res.*, vol. 43, no. 13, pp. 2709–2724, Jul. 2005.
- [49] M. Franchetti and C. Kress, "An economic analysis comparing the cost feasibility of replacing injection molding processes with emerging additive manufacturing techniques," *Int. J. Adv. Manuf. Technol.*, vol. 88, nos. 9–12, pp. 2573–2579, Feb. 2017.
- [50] S. Altendorfer-Kaiser, "Information logistics means to support a flexible production?" in *Proc. IFIP Int. Conf. Adv. Prod. Manage. Syst.*, 2015, pp. 414–421.
- [51] J. R. Bottum, J. F. Davis, P. M. Siegel, B. Wheeler, and D. G. Oblinger, "Cyberinfrastructure: In tune for the future," *Educause Rev.*, vol. 43, pp. 10–12, 2008.

- [52] D. Mourtzis, N. Milas, and A. Vlachou, "An internet of things-based monitoring system for shop-floor control," *J. Comput. Inf. Sci. Eng.*, vol. 18, 2018.
- [53] J. F. Davis and T. F. Edgar, "Smart process manufacturing—A vision of the future," in *Design for Energy and the Environment*. Boca Raton, FL, USA: CRC Press, 2009, pp. 175–192.
- [54] D. Kibira, K. C. Morris, and S. Kumaraguru, "Methods and tools for performance assurance of smart manufacturing systems," *J. Res. Nat. Inst. Standards Technol.*, vol. 121, p. 282, 2016.



AHMAD SAJJAD received the B.S. degree in electrical engineering (telecom) from Government College University Faisalabad, Pakistan, and the M.S. degree in engineering management from the College of Electrical and Mechanical Engineering, NUST, Rawalpindi, Pakistan. He is currently pursuing the Ph.D. degree in engineering management with the IED, University of Engineering and Technology Taxila, Pakistan.

From 2009 to 2017, he has a diversified industry and research and development experience of various projects (telecom system and services) at field and managerial positions, including a site engineer and a project manager. From 2017 to 2021, he was a Research Associate with the Industrial Engineering Department, UET Taxila. His research interests include technology management, smart system design and development, decision support systems, lean and technology integration industrial IoT and AI, and smart manufacturing.

Mr. Sajjad was a recipient of Full Funded Ph.D. Scholarship of worth PKR 2.1 million in 2017 from the University of Engineering and Technology Taxila.



WASIM AHMAD received the B.S. and M.S. degrees in mechanical engineering from the University of Engineering and Technology Taxila, Pakistan, in 2002 and 2007, respectively, and the Ph.D. degree from Canfield University, U.K., in 2012.

From 2005 to 2012, he was an Assistant Professor with the Mechanical Engineering Department, UET Taxila. From 2012 to 2017, he worked as the Director PGS with the Industrial Engineering Department, UET Taxila. He became the Chairman of the Industrial Engineering Department, UET Taxila, in 2017. He is currently working as a Professor with the IED, UET Taxila. His research interests include the lean product design and development, and cost estimation.

Dr. Ahmad received several awards and honors, including the Faculty Development Program (FDP) Ph.D. Fellowship at Canfield University, and register his patent under HEC Patent Support Program, Pakistan, in June 2020.



SALMAN HUSSAIN received the B.Sc. degree in mechanical engineering from the University of Engineering and Technology Taxila, Pakistan, in 2004, and the M.Sc. degree in mechatronics engineering and the Ph.D. degree in robotics from London South Bank University, in 2007 and 2012, respectively.

He is currently working as an Associate Professor and the Director Post Graduate Studies of the Industrial Engineering Department, University of Engineering and Technology Taxila. He is also the Director of the Automation and Control Centre, University of Engineering and Technology Taxila. His research interests include industry 4.0, automation, robotics, and additive manufacturing (3D printing).



RAJA MAJID MEHMOOD (Senior Member, IEEE) received the B.S. degree in computer science from Gomal University, Pakistan, the M.S. degree in software technology from Linnaeus University, Sweden, and the Ph.D. degree in computer engineering from the Division of Computer Science and Engineering, Chonbuk National University, South Korea.

He is currently an Assistant Professor with the School of Electrical and Computer Engineering, Information and Communication Technology Department, Xiamen University Malaysia, Sepang, Malaysia. He worked as a Research Professor with the Department of Brain and Cognitive Engineering, Korea University, Seoul, South Korea. He was a Lecturer with the Software Engineering Department, King Saud University, Saudi Arabia. He has authored more than 50 research articles and is supervising or co-supervising several graduate (M.S./Ph.D.) students. His main research interests include affective computing, brain–computer interfaces, information visualization, image processing, pattern recognition, multi-task scheduling, and software engineering.

Dr. Mehmood has served as a Reviewer of various international journals, including the *IEEE Communications Magazine*, the *IEEE TRANSACTIONS ON AFFECTIVE COMPUTING*, *International Journal of Information Technology and Decision Making*, *IEEE ACCESS*, *Multimedia Tools and Applications*, *ACM Transactions on Multimedia Computing Communications and Applications*, *Journal of King Saud University - Computer and Information Sciences*, *Biomedical Engineering (BME)*, the *IEEE INTERNET OF THINGS JOURNAL*, and the *IEEE TRANSACTIONS ON SYSTEMS, MAN AND CYBERNETICS*.

• • •