

Received October 18, 2021, accepted December 11, 2021, date of publication December 15, 2021, date of current version December 29, 2021.

Digital Object Identifier 10.1109/ACCESS.2021.3135870

Joint State Estimation Under Attack of Discrete Event Systems

QI ZHANG^{1,2}, CARLA SEATZU², (Senior Member, IEEE), ZHIWU LI^{1,3}, (Fellow, IEEE), AND ALESSANDRO GIUA², (Fellow, IEEE)

¹School of Electro-Mechanical Engineering, Xidian University, Xi'an 710071, China

²Department of Electrical and Electronic Engineering, University of Cagliari, 09123 Cagliari, Italy

³Institute of Systems Engineering, Macau University of Science and Technology, Taipa, Macau

Corresponding author: Zhiwu Li (zhwli@xidian.edu.cn)

This work was supported in part by the National Key Research and Development Program of China under Grant 2018YFB1700104; in part by the Natural Science Foundation of China under Grants 61472295, 61673309, and 61873342; in part by the Shaanxi Huashan Scholars, the Science and Technology Development Fund, Macau Special Administrative Region (MSAR), under Grant 122/2017/A3; and in part by the Project RASSR05871 MOSIMA financed by Region Sardinia, FSC 2014–2020, annuity 2017, Subject area 3, Action Line 3.1.

ABSTRACT The problem of state estimation in the setting of partially-observed discrete event systems subject to cyber attacks is considered. An operator observes a plant through a natural projection that hides the occurrence of certain events. The objective of the operator is that of estimating the current state of the system. The observation is corrupted by an attacker which can tamper with the readings of a set of sensors thus inserting some fake events or erasing some observations. The aim of the attacker is that of altering the state estimation of the operator. An automaton, called joint estimator, is defined to describe the set of all possible attacks. In more details, an unbounded joint estimator is obtained by concurrent composition of two state observers, the attacker observer and the operator observer. The joint estimator shows, for each possible corrupted observation, the joint state estimation, i.e., the set of states consistent with the uncorrupted observation and the set of states consistent with the corrupted observation. Such a structure can be used to establish if an attack function is harmful w.r.t. a misleading relation. Our approach is also extended to the case in which the attacker may insert at most n events between two consecutive observations.

INDEX TERMS Discrete event systems, state estimation, cyber attacks.

I. INTRODUCTION

Cyber-physical systems are intelligent interconnected systems which are particularly exposed to network-based malicious attacks. Their security is a topic which during the last years has received much attention in different information and communications technology (ICT) communities such as automatic control [1], [2], computer science and engineering [3], [4], and telecommunications [5].

In the domain of automatic control, the security of dynamical systems has been addressed with two main formalisms. The first one is that of time-driven systems, either in continuous time [6], [7] or in discrete time [8], [9]. In [6], the issue of reliable control in cyber-physical system under attack has been investigated. Rabehi *et al.* [7] design a secure interval observer for solving the problem of state estimation. In [8], the issue of reachability analysis in discrete-time systems under attack has been studied. Finally,

The associate editor coordinating the review of this manuscript and approving it for publication was Lo'ai A. Tawalbeh.

Zhang *et al.* [9] propose the problem of data-driven resilient control against cyber attacks.

The second formalism is that of discrete-event systems, where time driven dynamics are abstracted and a logical (non numerical) approach based on formal languages is adopted. The problem of attack detection in the framework of discrete event systems is addressed in [10]–[12]. In [13] the focus is on fault diagnosis of discrete event systems under attack. The problem of opacity enforcement by insertion functions under energy constraints has been investigated in [14]. The problem of supervisory control of discrete event systems under attack has been considered in [15]–[24].

Mainly inspired by some recent works [25]–[28], we address the problem of state estimation in the setting of partially-observed discrete event systems subject to cyber attacks. In this paper, which is an extended version of [29],¹ we consider a plant modeled as a discrete event system with

¹In [29] we only provided preliminary ideas by considering a less general problem statement. Furthermore, no algorithm was formally presented therein.

state set X , whose evolution is observed by an operator. The occurrence of a subset of events E_o , called *observable events*, can be detected by sensors while all other events, called *silent events*, produce no observation. An evolution of the plant produces an observed word $s \in E_o^*$ which the operator uses to determine the set of *consistent states* $\mathcal{C}(s) \subseteq X$, i.e., the set of states in which the system may be when s has been produced.

We assume that an attacker, which has a full knowledge of the plant, may corrupt the sensor readings. This could happen because either the attacker can gain direct control of a sensor or it can corrupt messages between the plant and the operator assuming they are connected through a network. The particular attack model we adopt, among those that have been presented in the literature, is based on the one considered by Meira-Góes *et al.* [26]. In particular, the attacker may insert in the word observed by the operator fake occurrences of *compromised events* or, on the contrary, may erase the occurrence of such events. In addition, we consider the possibility that the length of a word inserted by the attacker between the occurrence of two observable events may be n -bounded.

The attacker aims to mislead an operator. Under attack, an observation $s \in E_o^*$ produced by a plant can be changed into a corrupted observation $s' \in E_o^*$ and as a result the operator computes a state estimate $\mathcal{C}(s') \subseteq X$, which is in general incorrect. The attacker may have arbitrary goals. As an example, it may want to hide the fact that the plant has reached a critical state such that the operator does not activate appropriate protections that are fundamental for the system safeness. In all generality, we formalize a malicious goal by introducing a *misleading relation* $\mathcal{R} \subseteq 2^X \times 2^X$ and we say that an attack is *harmful* if there exists some observation s that can be changed into a corrupted observation s' such that $(\mathcal{C}(s), \mathcal{C}(s')) \in \mathcal{R}$.

In this paper, we first show how to construct two particular automata, called *attacker observer* and *operator observer*, which are defined on an augmented *attack alphabet* which includes the observable events of the plant and the events describing the action of the attacker. Based on concurrent composition of these two observers, we design a *joint estimator*, which describes all possible attacks. Finally, by inspection of such a structure one can determine if the attack function is harmful w.r.t. a misleading relation.

A. LITERATURE REVIEW

The problem of estimation under attack has been considered by relatively few authors in the automatic control literature.

In [30]–[32] the state estimation problem for time-driven models is studied.

Ding *et al.* [30] propose the problem of remote state estimation under denial-of-service attacks. A sensor needs to choose a channel to transmit the data packets, while an attacker needs to choose a channel to attack. They formalize such a problem as a two player stochastic game between the sensor and the attacker, and present optimal

strategies in terms of computational complexity for both sides, respectively.

Peng *et al.* [31] consider the issue of optimal attack energy allocation against remote state estimation. An optimal attack strategy that can result in maximal estimation error covariances is derived. Finally, they prove that the optimal strategy has a threshold structure.

Cheng *et al.* [32] develop an attack strategy that can degrade the estimation performance by tampering with the sensors, eavesdropping the measurements, and injecting false feedback information. They conclude that, with the presence of an attacker, the mean-squared stability condition of the state estimation is weakened.

In this work we consider discrete-event models, and the approaches developed in the above mentioned literature cannot be adopted. The state estimation problem for discrete event systems so far has not been studied in all generality, but has been partially addressed in the context of supervisory control. Here we mention a few recent publications which have inspired our work.

Tong *et al.* [25] present a new finite structure called parallel observer, which allows to simultaneously describe the observations of the supervisor and of the attacker. Based on the parallel observer, a maximally permissive supervisor is developed to enforce current-state opacity.

Meira-Góes *et al.* [26] propose a novel bipartite transition structure in the framework of discrete event systems, namely, Insertion-Deletion Attack structure, and present a game-like relationship between the supervisor and the environment (the plant and the attacker) to determine if the attacker can lead the plant to a forbidden state without being detected by the supervisor.

Lima *et al.* [27] propose a defense policy that prevents cyber attacks at sensor and actuator layer in supervisory control systems. It is assumed that the attacker can alter the observation of events in a set of events Σ_{vs} , and modify the enabling of events in a set of events Σ_{va} . The detectable network attack security and undetectable network attack security are introduced to prevent the plant from reaching forbidden states.

Su [28] addresses the problem of attack-with-bounded-sensor-reading-alteration (ABSRA), where the attacker can intercept the sensor readings from the plant and arbitrarily alter them but with an upper bound on the length of the altered observation word. In this way the attacker can cheat the supervisor, which will lead the plant to the undesirable states. The author also develops a supervisor that is robust to ABSRA.

We point out that significant differences exist between the problem setting considered in this paper and the problem setting dealt in most of the papers in the literature, including the above mentioned ones. What we propose is a methodology for studying how the possible choices of the attacker can affect the estimate of the operator. On the contrary, previous works on cyber attacks in the DES literature, including [15], [26]–[28], consider the case

of an operator/supervisor: in such a case the goal of the attacker is to beguile the supervisor so that a specification is violated, i.e., the plant reaches a forbidden state or generates a forbidden evolution.

The proposed approach can be applied not only to the case in which an operator-supervisor controls a plant in closed-loop — as in the above mentioned papers — but in more general settings, where the operator may have goals of different nature. As an example, in our framework one may study how cyber attacks disturb an operator-monitor which takes decisions based on its estimation of the plant state or an operator-diagnoser which aims to detect the occurrence of faults. *Mutatis mutandis*, our approach can also be used for addressing a problem of opacity enforcing: in such a case the operator is an intruder that wants to infer a secret and the attacker is the agent that corrupts the observation to thwart the intruder.

B. CONTRIBUTIONS AND STRUCTURE OF THE PAPER

This paper contains several original contributions.

- The problem of *joint state estimation under attack* is formalized; *harmful attacks* are characterized in general terms by means of a *misleading relation*.
- Based on the notion of *attack alphabet* and *attack words*, which describe how observations can be corrupted by the attacker we show how to construct two different observers: they describe the state estimates computed by the attacker and by the operator for each corrupted observation.
- A formal methodology to design a *joint estimator* is presented. This automaton, constructed as the concurrent composition of the two observers, describes all possible attacks.
- The joint estimator shows, for each possible corrupted observation, the joint state estimation, i.e., the set of states consistent with the uncorrupted observation and the set of states consistent with the corrupted observation. Such a structure also indicates if a harmful attack exists.

The rest of the paper is organized as follows. In Section II, we recall the basic notions of finite-state automata and of state estimation via observers. In Section III, we first describe the adopted attack model, and then formalize the problem considered in this paper. In Section IV, we develop two observers: attacker observer and operator observer. In Section V, we define the unbounded joint estimator as the concurrent composition of such observers. Then, we define an automaton that allows us, again via concurrent composition, to define a bounded joint estimator, starting from the unbounded one. Conclusions are finally drawn in Section VI where we also discuss our future lines of research in this framework.

II. PRELIMINARIES

Given an *alphabet* E , let E^* denote the set of all words on the alphabet. Given two words $\sigma_1, \sigma_2 \in E^*$, let $\sigma_1\sigma_2$ denote

their *concatenation*. Similarly, given two languages $L_1, L_2 \subseteq E^*$, we denote their concatenation L_1L_2 and when $L_1 = \{\sigma\}$ we also write $L_1L_2 = \sigma L_2$.

A *deterministic finite-state automaton* (DFA) is a four-tuple $G = (X, E, \delta, x_0)$, where X is the set of states, E is the set of events (alphabet), $\delta : X \times E \rightarrow X$ is the transition function, and x_0 is the initial state. The transition function can be extended to $\delta^* : X \times E^* \rightarrow X$ such that $\delta^*(x, \varepsilon) = x$, and $\delta^*(x, \sigma e) = \delta(\delta^*(x, \sigma), e)$ for all $x \in X$, $e \in E$ and $\sigma \in E^*$. The *generated language* of G is defined as $L(G) = \{\sigma \in E^* \mid \delta^*(x_0, \sigma) \text{ is defined}\}$.

Given two alphabets E' and E with $E' \subseteq E$, the *natural projection* on E' , $P_{E'} : E^* \rightarrow (E')^*$ is defined as [33]:

$$P_{E'}(\varepsilon) := \varepsilon \quad P_{E'}(\sigma e) := \begin{cases} P_{E'}(\sigma)e & \text{if } e \in E', \\ P_{E'}(\sigma) & \text{if } e \in E \setminus E'. \end{cases} \quad (1)$$

Therefore, given a word $\sigma \in E^*$, its natural projection on E' is obtained by erasing events that do not belong to E' .

The *concurrent composition* of two languages is defined as $L_1 \parallel L_2 = \{\sigma \in E^* \mid P_{E_1}(\sigma) \in L_1, P_{E_2}(\sigma) \in L_2\}$, where E_1 and E_2 are alphabets of L_1 and L_2 , respectively, and $E = E_1 \cup E_2$. The concurrent composition operator can also be defined for DFA. In particular, given two DFA G' and G'' , their *concurrent composition*, denoted as $G = G' \parallel G''$, generates language $L(G) = L(G') \parallel L(G'')$.

A *partially-observed deterministic finite-state automaton* is denoted as $G = (X, E, \delta, x_0)$, where $E = E_o \cup E_{uo}$, E_o is the *set of observable events*, and E_{uo} is the *set of unobservable events*. In the following, to keep the notation simple, we denote as $P : E^* \rightarrow E_o^*$ the natural projection on E_o . The *inverse projection* $P^{-1} : E_o^* \rightarrow 2^{E^*}$ is defined as $P^{-1}(s) = \{\sigma \in E^* \mid P(\sigma) = s\}$, where $\sigma \in E^*$, and $s \in E_o^*$.

When a partially-observed DFA generates a word $\sigma \in L(G)$ it produces the observation $s = P(\sigma) \in E_o^*$. However, in general a given observation may be produced by more than one generated word. The *set of words consistent with observation* s is defined by

$$\mathcal{S}(s) = P^{-1}(s) \cap L(G) = \{\sigma \in L(G) \mid P(\sigma) = s\}$$

and denotes the set of words generated by the DFA that produce observation s .

Correspondingly, the *set of states consistent with observation* s is defined by

$$\mathcal{C}(s) = \{x \in X \mid (\exists \sigma \in \mathcal{S}(s)) \delta^*(x_0, \sigma) = x\}$$

and denotes the set of states in which the DFA can be when observation s had been produced.

The set $\mathcal{C}(s) \subseteq X$ is also called the *state estimate* corresponding to observation $s \in E_o^*$. The problem of state estimation of a partially-observed DFA G can be solved, in all generality, constructing a new structure called its *observer* (see [34] for details).

Let us first define, for a partially-observed DFA G , the *unobservable reach* of a state $x \in X$. This set is denoted by $UR(x)$ and is defined as a set of states $x' \in X$ reached

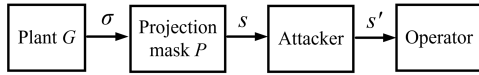

FIGURE 1. A plant G under attack.

from state x generating an unobservable word $\sigma \in E_{uo}^*$, i.e., $UR(x) = \{x' \mid \exists \sigma \in E_{uo}^*, \delta^*(x, \sigma) = x'\}$. This definition can be extended to a set of states $B \subseteq 2^X$ as follows:

$$UR(B) = \bigcup_{x \in B} UR(x).$$

The *observer* $Obs(G)$ of a partially-observed DFA $G = (X, E, \delta, x_0)$, is a DFA:

$$Obs(G) = (B, E_o, \delta_{obs}, b_0),$$

where the set of states is $B \subseteq 2^X$, the alphabet E_o is the set of observable events of G , the transition function $\delta_{obs} : B \times E_o \rightarrow B$ is defined as:

$$\delta_{obs}(b, e_o) := \bigcup_{x \in b} UR(\{x' \mid \delta(x, e_o) = x'\}),$$

and the initial state is $b_0 := UR(x_0)$.

As shown in [34], given a partially-observed DFA G with observer $Obs(G) = (B, E_o, \delta_{obs}, b_0)$, for any observation $s \in E_o^*$ produced by G it holds that $\mathcal{C}(s) = \delta_{obs}^*(b_0, s)$.

III. THE JOINT STATE ESTIMATION PROBLEM

In this section, first, we introduce an attack model and an original formalism to represent it. Then, we formalize the problem considered in this paper.

A. ATTACK MODEL

In this paper we consider a plant modeled by a partially observable DFA with set of observable events E_o and set of unobservable events E_{uo} . Referring to Fig. 1, if σ is a word generated by the plant, the *observed word* is $s = P(\sigma)$. An attacker may corrupt the output signals produced by the plant with the effect of inserting in the observation some events that did not occur, or erasing some events that have occurred. Such a *corrupted observation* is denoted as s' (a sequence of events in E_o), and the operator constructs its *state estimation* based on s' . In our framework, we assume the operator monitors the plant to estimate its current state: the objective of the attacker is to corrupt the observation in such a way that a correct estimation is not possible.

Definition 1: [26] The *set of compromised events* is denoted as $E_{com} \subseteq E_o$. It includes all the observable events that can be corrupted by the attacker, either inserting them in the operator observation, even if they have not actually occurred, or erasing them in the operator observation. \diamond

The definition of compromised events was first proposed in [26]. However, while in [26] the authors assume that all the compromised events can be inserted and erased by the attacker, here we slightly generalize the definition as follows.

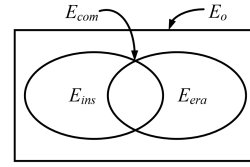

FIGURE 2. The relationship among the subsets of E_o .

The set of compromised events that can be inserted in the observer evolution is denoted as E_{ins} , and the set of events that can be erased is denoted as E_{era} . To keep the presentation general, we assume that E_{ins} and E_{era} are not necessarily disjoint.

The relationship among the different subsets of observable events E_o is clarified in Fig. 2.

We now formally describe the action of the attacker in terms of two new types of events that it can generate. More precisely, even if it is possible to directly define the attacker as a finite-state transducer that “translates” an observed word s into a corrupted observation s' (see Fig. 1), for a reason that will appear clear in the following, we prefer to characterize the attacker’s action in terms of a new word defined on a so-called *attack alphabet* E_a .

Definition 2: The *attack alphabet* is defined as $E_a = E_o \cup E_+ \cup E_-$, and we assume that E_o, E_+ , and E_- are disjoint sets.

The *set of inserted events* [26] is denoted as E_+ , namely $E_+ = \{e_+ \mid e \in E_{ins}\}$. The occurrence of an event $e_+ \in E_+$ denotes the fact that the attacker inserts in the operator observation an event $e \in E_{ins}$ that has not occurred in reality.

The *set of erased events* [26] is denoted as E_- , namely $E_- = \{e_- \mid e \in E_{era}\}$. The occurrence of an event $e_- \in E_-$ denotes the fact that the attacker erases from the operator’s observation event $e \in E_{era}$ generated by plant. \diamond

Given a bound $n \in \mathbb{N} \cup \{\infty\}$, let $E_+^{\leq n} = \{w_+ \in E_+^* \mid |w_+| \leq n\}$ denote the set of words on alphabet E_+ whose length does not exceed n . Note that if $n = \infty$ then $E_+^{\leq n} = E_+^*$.

Definition 3: Given a plant G with a set of compromised events $E_{com} = E_{ins} \cup E_{era}$, let $n \in \mathbb{N} \cup \{\infty\}$ be a bound. An n -bounded attacker can be defined by an *attack function* $f_n : P(L(G)) \rightarrow E_a^*$, where E_a is the attack alphabet (Definition 2), satisfying the following conditions:

- (a) $f_n(\varepsilon) \in E_+^{\leq n}$,
- (b) $\forall se \in P(L(G))$ with $s \in E_o^*$:

$$\begin{cases} f_n(se) \in f_n(s)\{e_-, e\}E_+^{\leq n} & \text{if } e \in E_{era}, \\ f_n(se) \in f_n(s)\{e\}E_+^{\leq n} & \text{if } e \in E_o \setminus E_{era}. \end{cases} \quad (2)$$

\diamond

In Definition 3, condition (a) means that the attacker can insert a bounded word $w_+ \in E_+^{\leq n}$ at the initial state, before any event generated by the plant is observed. Condition (b) implies that if an event $e \in E_{era}$ occurs, the attacker can either erase event e or not erase it, and then insert any word $w_+ \in E_+^{\leq n}$. If an event $e \in E_o \setminus E_{era}$ occurs, then the attacker can insert any word $w_+ \in E_+^{\leq n}$ after e .

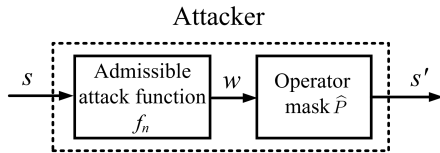

FIGURE 3. Internal structure of the attacker with observed word $s \in E_o^*$, attack word $w \in E_a^*$, and corrupted observation $s' \in E_o^*$.

We notice that imposing that the attacker may insert at most n consecutive events between any two observed events, makes sense in practice. Indeed, even if our model is purely logical, a real system can produce in a finite time just a finite number of events. If the attacker could introduce an arbitrarily large number of events between two consecutive observed events, this would lead to an anomalous behavior as observed by the operator.

We denote as \mathcal{F}_n the set of attack functions for a given $n \in \mathbb{N} \cup \{\infty\}$.

Definition 4: The language modified by an attack function f_n is called *attack language*. It is denoted as $L(f_n, G)$ and is defined as $L(f_n, G) = f_n(P(L(G)))$. A word $w \in L(f_n, G)$ is called an *attack word*.

The set of all the attack languages relative to a given $n \in \mathbb{N} \cup \{\infty\}$, denoted as $L(\mathcal{F}_n, G)$, is defined as

$$L(\mathcal{F}_n, G) = \bigcup_{f_n \in \mathcal{F}_n} L(f_n, G) = \bigcup_{f_n \in \mathcal{F}_n} f_n(P(L(G))). \quad (3)$$

Given two integer numbers n and n' , $\mathcal{F}_n \subseteq \mathcal{F}_{n'}$ if $n \leq n'$. Furthermore, $\mathcal{F}_n \subseteq \mathcal{F}_\infty$ for all $n < \infty$.

Definition 5: The *operator mask* $\hat{P} : E_a^* \rightarrow E_o^*$ is defined as:

$$\hat{P}(\varepsilon) = \varepsilon, \hat{P}(we') = \begin{cases} \hat{P}(w)e & \text{if } e' = e \in E_o \vee \\ & e' = e_+ \in E_+, \\ \hat{P}(w) & \text{if } e' = e_- \in E_- \end{cases} \quad (4)$$

The internal structure of the attacker is visualized in Fig. 1 as a black box taking an observation s as an input and producing a corrupted observation s' as an output. Such an internal structure is sketched in more detail in Fig. 3.

Here the observed word is $s = P(\sigma)$ (a sequence of events in E_o). The attacker corrupts the observation according to the attack function f_n , producing $w \in L(f_n, G) \subseteq E_a^*$. Such a sequence is projected via \hat{P} on E_o , generating a word s' . The plant operator constructs its state estimation based on s' .

B. PROBLEM STATEMENT

In this subsection we first describe the possible goals of the attacker on which we are focusing in this paper. Then we formalize the problem statement. To this aim we introduce a relation $\mathcal{R} \subseteq 2^X \times 2^X$, called a *misleading relation*. If s and s' in E_o^* denote, respectively, the generic uncorrupted and corrupted observation of the operator, the goal of the attacker is achieved whenever

$$(\mathcal{C}(s), \mathcal{C}(s')) \in \mathcal{R},$$

i.e., whenever the pair (set of states consistent with the uncorrupted observation, set of states consistent with the corrupted observation) belongs to \mathcal{R} . The following definition formalizes this.

Definition 6: Let $G = (X, E, \delta, x_0)$ be a plant with set of observable events E_o and its observer $Obs(G) = (B, E_o, \delta_{obs}, b_0)$. An attack function f_n is *harmful* w.r.t. a relation $\mathcal{R} \subseteq 2^X \times 2^X$ if there exists an observation $s \in P(L(G))$ generated by the plant, whose set of consistent states is $\mathcal{C}(s) = \delta_{obs}^*(b_0, s)$, such that s can be corrupted into a word $s' = \hat{P}(f_n(s))$ whose corresponding set of consistent states is $\mathcal{C}(s') = \delta_{obs}^*(b_0, s')$, and $(\mathcal{C}(s), \mathcal{C}(s')) \in \mathcal{R}$. \diamond

Different physical problems can be described in this setting by suitably defining relation \mathcal{R} . A significant example is the following one.

Example 1: Assume that a subset of states of a system, $X_{cr} \subseteq X$, is labeled as *critical* in the sense that when the system is in one of such states, a protective action must be taken to avoid possible damages. The operator is monitoring the system evolution in order to establish when one of such states is reached. Obviously, if the operator does not realize that a critical state has been reached, no action is taken and the system behaviour can be seriously compromised. The effectiveness of an attacker that aims to affect the system observation in order to prevent the operator to realize when a critical state is reached, can be evaluated via the misleading relation defined as $\mathcal{R} = \{(X', X'') \mid X' \cap X_{cr} \neq \emptyset \text{ and } X'' \cap X_{cr} = \emptyset\}$. Indeed, the attack is harmful if there exists at least one observation s such that $\mathcal{C}(s) \cap X_{cr} \neq \emptyset$ (meaning that the system may be in a critical state) which can be corrupted to an observation s' with $\mathcal{C}(s') \cap X_{cr} = \emptyset$ (meaning that the operator excludes the possibility that the system is in a critical state). \diamond

Given a plant $G = (X, E, \delta, x_0)$ with set of observable events E_o , and a misleading relation $\mathcal{R} \subseteq 2^X \times 2^X$, the main contribution of this paper consists in providing a tool, called joint estimator that contains all the possible actions (insert and/or erase observations) that an attacker may implement during the system evolution. On the basis of such a structure, the attacker can establish if the attacks are harmful to the plant.

IV. ATTACKER OBSERVER AND OPERATOR OBSERVER

In this section we introduce two special structures, called *Attacker Observer* and *Operator Observer*, which are fundamental to derive the solution to the joint estimation problem we are considering.

A. ATTACKER OBSERVER

The attacker observer $Obs_{att}(G)$ describes all possible attack words that can be generated by functions in \mathcal{F}_∞ and the corresponding sets of consistent states of the system. Since attacks are performed by the attacker, it knows which observations originate from events that have really occurred in the plant (E_o), which observations have been erased (E_-), and which observations have been inserted (E_+). The attacker observer $Obs_{att}(G)$ can be constructed using Algorithm 1.

Algorithm 1 Construction of the Attacker Observer $Obs_{att}(G)$

Input: An observer $Obs(G) = (B, E_o, \delta_{obs}, b_0)$, E_{ins} , and E_{era} .

Output: An attacker observer $Obs_{att}(G) = (B, E_a, \delta_{att}, b_0)$.

- 1: Let $E_a := E_o \cup E_+ \cup E_-$;
- 2: Let $\delta_{att} := \delta_{obs}$;
- 3: **for all** $e \in E_{era}$, **do**
- 4: **for all** $b \in B$, **do**
- 5: **if** $\delta_{att}(b, e) = b'$, **then**
- 6: $\delta_{att}(b, e_-) = b'$;
- 7: **end if**
- 8: **end for**
- 9: **end for**
- 10: **for all** $e \in E_{ins}$, **do**
- 11: **for all** $b \in B$, **do**
- 12: $\delta_{att}(b, e_+) = b$;
- 13: **end for**
- 14: **end for**

According to Algorithm 1, the set E_a is initially computed and the transition function of $Obs_{att}(G)$ is initialized at $\delta_{att} = \delta_{obs}$. Indeed, events in E_o are events actually occurring in the plant, thus when such events occur the attacker updates its state estimation according to the transition function of $Obs(G)$.

Then, for all $e \in E_{era}$ and for all $b \in B$, whenever $\delta_{att}(b, e)$ is defined, the algorithm imposes $\delta_{att}(b, e_-) = \delta_{att}(b, e)$. Indeed, the attacker knows that e_- corresponds to event e that has been canceled, thus the way it updates its estimation is the same in the case of e and e_- .

Finally, for all events $e \in E_{ins}$, and for all states $b \in B$, we add self-loops $\delta_{att}(b, e_+) = b$. Indeed, the attacker knows that events in E_+ are fake events that have not really occurred in the plant, thus it does not update its estimation based on them. In particular, self-loops correspond to the possibility of inserting an arbitrarily large number of such events, which is consistent with the fact that we are dealing with attack functions in \mathcal{F}_∞ .

Example 2: Consider a partially-observed plant $G = (X, E, \delta, x_0)$ in Fig. 4(a), where $E = E_o \cup E_{uo}$, $E_o = \{a, c, d, g\}$, and $E_{uo} = \{b\}$. The corresponding observer of G is shown in Fig. 4(b). Let $E_{ins} = \{c, d\}$, and $E_{era} = \{c, g\}$. The attacker observer constructed using Algorithm 1 is shown in Fig. 5(a).

Since events $c, g \in E_{era}$, and there is a transition labeled c from state $\{1, 2\}$ to state $\{3\}$ in the observer of the plant $Obs(G)$, we add transitions labeled c and c_- from state $\{1, 2\}$ to state $\{3\}$ in the attacker observer. Similar arguments can be used to explain transitions labeled c and c_- from state $\{5\}$ to state $\{6\}$, self-loops labeled g and g_- at state $\{4\}$. Then, since $c, d \in E_{ins}$, we add self-loops labeled c_+ and d_+ at all the states. \diamond

The following proposition provides a characterization of the attacker observer.

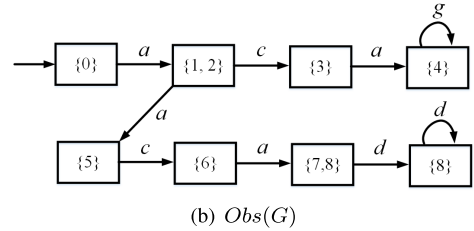
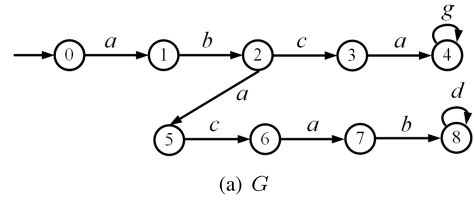

FIGURE 4. (a) A partially-observed plant G ; (b) its observer $Obs(G)$, where $E_o = \{a, c, d, g\}$.

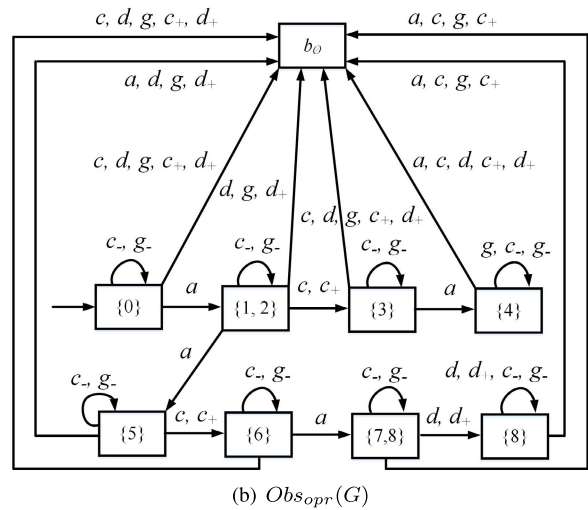
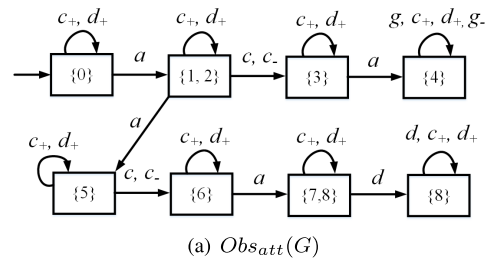

FIGURE 5. (a) Attacker observer in Example 2 and (b) operator observer in Example 3 for the plant in Fig. 4.

Proposition 1: Consider a plant G with set of observable events E_o and observer $Obs(G) = (B, E_o, \delta_{obs}, b_0)$. Let f_∞ be an attack function, \mathcal{F}_∞ be the set of attack functions, and $E_a = E_o \cup E_+ \cup E_-$ be an attack alphabet. Let $Obs_{att}(G)$ be the attacker observer constructed using Algorithm 1. It holds that:

- (a) $L(Obs_{att}(G)) = L(\mathcal{F}_\infty, G)$;
- (b) $\forall s \in P(L(G)), \forall f_\infty \in \mathcal{F}_\infty$ with $w = f_\infty(s) \in E_a^*$:

$$\delta_{att}^*(b_0, w) = \delta_{obs}^*(b_0, s).$$

Proof: (a) According to Algorithm 1, Step 2 implies that $L(Obs_{att}(G))$ contains all words that can be observed if no attack occurs. Correspondingly, according to the definition of attack function (Definition 3), the set of attack languages $L(\mathcal{F}_\infty, G)$ also contains these words since the attacker does not reduce the language of the plant.

Steps 3–9 guarantee that all attacks resulting from the cancellation of events in E_{era} are considered. Correspondingly, according to the definition of attack function, each time the plant generates an event $e \in E_{era}$, then the attacker can erase it.

Finally, Steps 10–14 guarantee that all attacks resulting from the insertion of an arbitrarily large number of events in E_{ins} are taken into account. Again, according to the definition of attack function, the attacker can insert any word $w_+ \in E_+^{\leq n}$ whenever possible.

Thus, we can conclude that $L(Obs_{att}(G)) = L(\mathcal{F}_\infty, G)$.

(b) We prove this by induction on the length of s . If $s = \varepsilon$, the result follows from the fact that, by definition of attack function, it is $f_\infty(\varepsilon) \in E_+^{\leq n}$, and by Steps 10–14, events in E_+ lead to self-loops in $Obs_{att}(G)$.

Let us now consider a generic word $s \in P(L(G))$ with length greater than one, written as $s = \bar{s}e$, where $\bar{s} \in P(L(G))$ and $e \in E_o$. Assume the result holds for \bar{s} . We prove that it also holds for $s = \bar{s}e$ considering the following two possible cases.

If $e \in E_{era}$, by the definition of attack function, $w \in \bigcup_{f_\infty \in \mathcal{F}_\infty} f_\infty(\bar{s})\{e_-, e\}E_+^{\leq n}$ is true. According to Steps 3–9, events e and e_- are dealt with in the same manner when defining the transition function δ_{att} . Finally, as just pointed out, according to Steps 10–14, events in E_+ lead to self-loops in $Obs_{att}(G)$.

Finally, if $e \in E_o \setminus E_{era}$, by the definition of attack function, $w \in \bigcup_{f_\infty \in \mathcal{F}_\infty} f_\infty(\bar{s})eE_+^{\leq n}$ is true. Thus the result follows from the fact that, according to Steps 10–14, events in E_+ lead to self-loops in $Obs_{att}(G)$ and events in E_o are dealt with in the same manner in $Obs_{att}(G)$ and $Obs(G)$. \square

Now we discuss the computational complexity of constructing the attacker observer $Obs_{att}(G)$. Given a plant G with set of states X , the observer of the plant $Obs(G)$ can be constructed in $2^{|X|}$ steps. According to Algorithm 1, $Obs_{att}(G)$ has the same number of states as $Obs(G)$; thus the complexity of building $Obs_{att}(G)$ is $O(2^{|X|})$.

B. OPERATOR OBSERVER

The attack model we are considering may change an observation s into a corrupted observation s' which cannot be produced by the nominal plant. In this case the operator understands that the system is under attack. This can be formalized as follows.

Definition 7: Consider a plant G . An attack function f_n is said to be *stealthy* if $\widehat{P}(L(f_n, G)) \subseteq P(L(G))$, where \widehat{P} is the operator mask. \diamond

In words, stealthiness requires that the set of words that an operator observes when the system is under attack is contained in the set of words the operator may observe when no attack occurs.

The operator observer $Obs_{opr}(G)$ generates two different sets of words. The first set includes all words on E_a^* that may either result from an uncorrupted observation of the plant or from a corrupted observation which keeps the attacker stealthy. The second set of words includes all the previous words continued with a symbol in E_a so that the resulting word is not consistent with an uncorrupted observation. While the words in the first set lead to a set of states that according to the operator are consistent with the perceived observation, those in the second set lead to a dummy state denoted as b_\emptyset . The operator observer $Obs_{opr}(G)$ can be constructed using Algorithm 2, as shown below.

Algorithm 2 Construction of the Operator Observer $Obs_{opr}(G)$

Input: An observer $Obs(G) = (B, E_o, \delta_{obs}, b_0)$, E_{ins} , and E_{era} .

Output: An operator observer $Obs_{opr}(G) = (B_{opr}, E_a, \delta_{opr}, b_0)$.

```

1: Let  $B_{opr} := B \cup b_\emptyset$ ;
2: Let  $E_a := E_o \cup E_+ \cup E_-$ ;
3: Let  $\delta_{opr} := \delta_{obs}$ ;
4: for all  $e \in E_{ins}$ , do
5:   for all  $b \in B$ , do
6:     if  $\delta_{opr}(b, e) = b'$ , then
7:        $\delta_{opr}(b, e_+) = b'$ ;
8:     end if
9:   end for
10: end for
11: for all  $e \in E_{era}$ , do
12:   for all  $b \in B$ , do
13:      $\delta_{opr}(b, e_-) = b$ ;
14:   end for
15: end for
16: for all  $e_a \in E_a$ , do
17:   for all  $b \in B$ , do
18:     if  $\delta_{opr}(b, e_a)$  is not defined, then
19:        $\delta_{opr}(b, e_a) = b_\emptyset$ ;
20:     end if
21:   end for
22: end for

```

According to Algorithm 2, the set of states $B_{opr} = B \cup b_\emptyset$ and the set of events E_a are initially computed. Then, the transition function of $Obs_{opr}(G)$ is initialized at $\delta_{opr} = \delta_{obs}$. Indeed, events in E_o are events actually occurring on the plant; when such events occur, the operator updates its state estimation according to the transition function of $Obs(G)$.

Furthermore, for all $e \in E_{ins}$ and for all $b \in B$, we impose $\delta_{opr}(b, e_+) = \delta_{opr}(b, e)$. Indeed, the operator does not distinguish between events in E_+ and the corresponding

events in E_{ins} . For all $e \in E_{era}$ and for all $b \in B$, we add self-loops $\delta_{opr}(b, e_-) = b$. Indeed, events in E_- correspond to no observation by the operator.

Finally, for all the events $e_a \in E_a$ that are not enabled at the generic state $b \in B$, let $\delta_{opr}(b, e_a) = b_\emptyset$. As a result, for all $b \in B$ and for all $e_a \in E_a$, function $\delta_{opr}(b, e_a)$ is defined. On the contrary, $\delta_{opr}(b_\emptyset, e_a)$ is undefined for all $e_a \in E_a$.

Example 3: Consider again the plant G in Fig. 4. Let $E_{ins} = \{c, d\}$ and $E_{era} = \{c, g\}$. The operator observer constructed using Algorithm 2 is visualized in Fig. 5(b).

Since $c, d \in E_{ins}$ and there is a transition labeled c from state $\{1, 2\}$ to state $\{3\}$ in $Obs(G)$, we add transitions labeled c and c_+ from state $\{1, 2\}$ to state $\{3\}$ in the operator observer. Similar arguments can be used to explain the transitions labeled c and c_+ from state $\{5\}$ to state $\{6\}$, the transitions labeled d and d_+ from state $\{7, 8\}$ to state $\{8\}$, and the self-loops labeled d and d_+ at state $\{8\}$. Then, since $c, g \in E_{era}$, we add self-loops labeled c_- and g_- at all the states. Finally, we add all the missing transitions to the new state b_\emptyset , which has no output arc. \diamond

To better characterize the properties of the operator observer, let us define two sets of words associated to an attack model as described in Subsection III-A.

Definition 8: The *set of stealthy words* on attack alphabet E_a is

$$W_s = \{w \in E_a^* \mid \widehat{P}(w) \in P(L(G))\},$$

while the *set of exposing words* on E_a is

$$W_e = \{we_a \in E_a^* \mid w \in W_s, e_a \in E_a, w e_a \notin W_s\}.$$

\diamond

In plain words, a stealthy word w produces an observed word $s' = \widehat{P}(w)$ which does not reveal the presence of the attacker because such an observation may have been produced by the plant. An exposing word is a non-stealthy word on E_a whose strict prefixes are all stealthy: hence it reveals the presence of the attacker but only at the last step.

The following proposition provides a characterization of the operator observer.

Proposition 2: Let G be a plant with set of observable events E_o and observer $Obs(G) = (B, E_o, \delta_{obs}, b_0)$. Given an attack alphabet $E_a = E_o \cup E_+ \cup E_-$ with set of stealthy words W_s and set of exposing words W_e , let $Obs_{opr}(G)$ be the operator observer constructed by Algorithm 2. It holds that:

- (a) $L(Obs_{opr}(G)) = W_s \cup W_e$;
- (b) $\forall w \in L(Obs_{opr}(G))$: if $w \in W_s$, then $\delta_{opr}^*(b_0, w) = \delta_{obs}^*(b_0, \widehat{P}(w))$; if $w \in W_e$, then $\delta_{opr}^*(b_0, w) = b_\emptyset$.

Proof: (a) Follows from Algorithm 2, and from the definitions of stealthy words, exposing words, and operator mask.

In more detail, Step 3 guarantees that all uncorrupted words belong to $L(Obs_{opr}(G))$. Steps 4–10 guarantee that, in $Obs_{opr}(G)$, events in E_+ lead to the same states of the corresponding events in E_{ins} . Steps 11–15 guarantee that, in $Obs_{opr}(G)$, events in E_- lead to self-loops. The above

steps guarantee that all the stealthy words $w \in W_s$ belong to $L(Obs_{opr}(G))$.

Finally, Steps 16–22 impose that, if after executing Steps 1–15, a certain event in E_a is not already enabled at a certain state of $Obs_{opr}(G)$, then such an event is enabled at such a state and leads to state b_\emptyset , where no other event may be executed. These steps ensure that all the exposing words $w \in W_e$ belong to $L(Obs_{opr}(G))$.

(b) We prove this by induction on the length of w . If $w = \varepsilon$, the result holds being $\widehat{P}(w) = \varepsilon$.

Consider now a word $w \in L(Obs_{opr}(G))$ with length greater than one. Assume $w \in W_s$, and let $w = w'e_a$. Assume that the result holds for a generic $w' \in W_s$. By definition of operator mask, if $e_a \in E_o \cup E_+$, then $\widehat{P}(w) = \widehat{P}(w')e \in \widehat{P}(w')\{e, \varepsilon\}$; otherwise $\widehat{P}(w) = \widehat{P}(w') \in \widehat{P}(w')\{e, \varepsilon\}$. Thus $\delta_{opr}^*(b_0, w) = \delta_{opr}^*(\delta_{opr}^*(b_0, w'), e_a)$. Then, $\delta_{obs}^*(b_0, \widehat{P}(w)) = \delta_{obs}^*(\delta_{obs}^*(b_0, \widehat{P}(w')), e)$ if $e_a \in E_o \cup E_+$, and $\delta_{obs}^*(b_0, \widehat{P}(w)) = \delta_{obs}^*(\delta_{obs}^*(b_0, \widehat{P}(w')), \varepsilon)$ if $e_a \in E_-$.

According to Algorithm 2 the transition function of $Obs_{opr}(G)$ starting for a generic state $b \in B$ is defined in the same way in case of e and e_+ (Steps 6 and 7), while it corresponds to a self-loop in the case of $e_- \in E_-$ (Step 13). As a result, we can conclude that $\delta_{opr}^*(b_0, w) = \delta_{obs}^*(b_0, \widehat{P}(w))$.

Finally, the last claim in (b) follows from the fact that, if $w \in W_e$, according to Algorithm 2, all the missing transitions end up in the new state b_\emptyset , thus $\delta_{opr}^*(b_0, w) = b_\emptyset$. \square

Given a plant G with set of states X , the observer of the plant $Obs(G)$ can be constructed in $2^{|X|}$ steps. According to Algorithm 2, the operator observer $Obs_{opr}(G)$ has at most $2^{|X|} + 1$ states; thus the complexity of constructing $Obs_{att}(G)$ is $O(2^{|X|})$.

V. UNBOUNDED AND n -BOUNDED JOINT ESTIMATORS

In this section we define a particular DFA, called *joint estimator*, which is defined on alphabet E_a and contains all attack words that can be generated by the plant.

Here we distinguish two different cases. In the first case, the attack function belongs to \mathcal{F}_∞ . We call *unbounded joint estimator* the corresponding DFA, denoted as A_∞ . In the second case, the attack function belongs to \mathcal{F}_n for a given $n \in \mathbb{N}$. We call *n-bounded joint estimator* the corresponding DFA and denote it as A_n .

A. UNBOUNDED JOINT ESTIMATOR

Let us first formalize the definition of A_∞ .

Definition 9: The *unbounded joint estimator* $A_\infty = (R, E_a, \delta_a, r_0)$ w.r.t. G and E_{com} is defined as $A_\infty = Obs_{att}(G) \parallel Obs_{opr}(G)$. \diamond

Example 4: Consider again the plant G in Fig. 4 whose attacker observer and operator observer are visualized in Figs. 5(a) and (b), respectively. The unbounded joint estimator A_∞ built according to Definition 9 is shown in Fig. 6.

By inspecting the unbounded joint estimator A_∞ in Fig. 6, once event a occurs on the plant, the attacker executes event

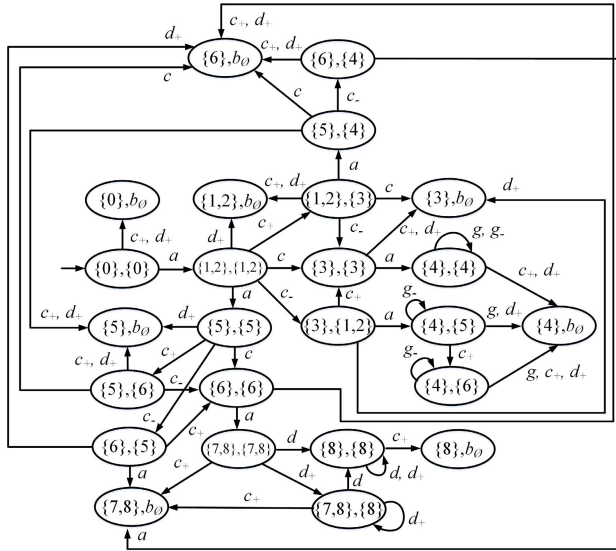

FIGURE 6. Unbounded joint estimator A_∞ in Example 4.

a on A_∞ starting from the initial state $(\{0\}, \{0\})$. Thus state $(\{1, 2\}, \{1, 2\})$ is reached. Now, the attacker may wait for a new event occurring on the plant, a or c in this case. Alternatively, the attacker may insert an event c or d in the operator observation, which correspond to execute c_+ or d_+ , respectively, in A_∞ . Then, the attacker may erase event c in the operator observation, which corresponds to execute c_- in A_∞ , and so on.

We notice that, any word $w \in E_a^*$ generated by the unbounded joint estimator allows us to argue the following three information: (1) which is the observation $s \in E_o^*$ actually produced by the system; (2) how the attacker corrupted it (which events it has inserted and/or erased); (3) which is the word $s' \in E_o^*$ observed by the operator. Consider as an example, the word $w = ac_-ac_+ \in E_a^*$ that leads to state $(\{4\}, \{6\})$. This corresponds to the observation $s = acca$ produced by the system. The attacker erases the observation c after the first a and inserts the dummy observation c after the second a , resulting in the word $s' = \hat{P}(w) = aac$ observed by the operator. \diamond

The following theorem provides a characterization of the unbounded joint estimator.

Theorem 1: Let G be a plant with set of observable events E_o and observer $Obs(G) = (B, E_o, \delta_{obs}, b_0)$. Given attack alphabet E_a , with set of stealthy words W_s and set of exposing words W_e , let $A_\infty = (R, E_a, \delta_a, r_0)$ be its unbounded joint estimator. It holds that:

- (a) $L(A_\infty) = L(\mathcal{F}_\infty, G) \cap (W_s \cup W_e)$;
- (b) $\forall s \in P(L(G)), \forall f_\infty \in \mathcal{F}_\infty$ with $w = f_\infty(s) \in E_a^*$:
 - (i) if $w \in W_s$ then $\delta_a^*(r_0, w) = (b_a, \bar{b}_a) \iff \delta_{obs}^*(b_0, s) = b_a, \delta_{obs}^*(b_0, \hat{P}(w)) = \bar{b}_a$;
 - (ii) if $w \in W_e$ then $\delta_a^*(r_0, w) = (b_a, b_\emptyset) \iff \delta_{obs}^*(b_0, s) = b_a, \delta_{obs}^*(b_0, \hat{P}(w))$ is not defined.

Proof: (a) Follows from Propositions 1 and 2 and Definition 9. Indeed, by Proposition 1, it holds that $L(Obs_{att}(G)) = L(\mathcal{F}_\infty, G)$ and by Proposition 2, it holds

that $L(Obs_{opr}(G)) = W_s \cup W_e$. Since A_∞ is defined as the concurrent composition of $Obs_{att}(G)$ and $Obs_{opr}(G)$, having the same alphabet, its language is equal to the intersection of the languages of the two DFA.

(b) We first consider the case: $w \in W_s$.

(If) Assume that $\delta_{obs}^*(b_0, s) = b_a, \delta_{obs}^*(b_0, \hat{P}(w)) = \bar{b}_a$. By Propositions 1 and 2, it holds that $\delta_{obs}^*(b_0, s) = \delta_{att}^*(b_0, w)$ and $\delta_{obs}^*(b_0, \hat{P}(w)) = \delta_{opr}^*(b_0, w)$, namely, $\delta_{att}^*(b_0, w) = b_a$ and $\delta_{opr}^*(b_0, w) = \bar{b}_a$. Since $A_\infty = Obs_{att}(G) \parallel Obs_{opr}(G)$, by definition of concurrent composition, it is $\delta_a^*(r_0, w) = (b_a, \bar{b}_a)$.

(Only if) Assume that $\delta_a^*(r_0, w) = (b_a, \bar{b}_a)$. Since $A_\infty = Obs_{att}(G) \parallel Obs_{opr}(G)$, by definition of concurrent composition, it holds that $\delta_{att}^*(b_0, w) = b_a$ and $\delta_{opr}^*(b_0, w) = \bar{b}_a$. By Propositions 1 and 2, it is $\delta_{obs}^*(b_0, s) = \delta_{att}^*(b_0, w)$ and $\delta_{obs}^*(b_0, \hat{P}(w)) = \delta_{opr}^*(b_0, w)$, namely, $\delta_{obs}^*(b_0, s) = b_a$ and $\delta_{obs}^*(b_0, \hat{P}(w)) = \bar{b}_a$.

Let us finally consider the case $w \in W_e$. The proof follows from the definition of concurrent composition and the fact that a word w in the operator observer yields state b_\emptyset if and only if $\hat{P}(w) \notin P(L(G))$, i.e., $\delta_{obs}^*(b_0, \hat{P}(w))$ is not defined. \square

In plain words, Theorem 1 implies that the language of the joint estimator contains all words on alphabet E_a that can be generated under attack and that are either stealthy or exposing. In addition the state (b_a, \bar{b}_a) reached in the joint estimator by a stealthy word $w = f_\infty(s)$ describes the joint estimation composed by the correct observation $b_a = \mathcal{C}(s)$ that would have been computed by the operator without attack, and the corrupted observation $\bar{b}_a = \mathcal{C}(s') = \mathcal{C}(\hat{P}(w))$ due to the attack. An exposing word $w = f_\infty(s)$ reaches a state (b_a, b_\emptyset) where $b_a = \mathcal{C}(s)$ is the correct observation that would have been computed by the operator without attack.

Let us show how to select a harmful attack function on the basis of the unbounded joint estimator A_∞ .

Proposition 3: Given a plant $G = (X, E, \delta, x_0)$ with set of compromised events E_{com} , let $\mathcal{R} \subseteq 2^X \times 2^X$ be the misleading relation, and $A_\infty = (R, E_a, \delta_a, r_0)$ be the unbounded joint estimator. An attack function f_n is harmful iff $R \cap \mathcal{R} \neq \emptyset$.

Proof: (If) Assume that there exists a state $r = (b_a, \bar{b}_a)$ of the joint estimator A such that $r \in R \cap \mathcal{R}$. Since $r \in R$, then there exists an attack word w with $\delta_a(r_0, w) = r$. According to the definition of attack function (Definition 3), there exists an observation $s \in P(L(G))$ such that $w = f_n(s)$, where P is the natural projection.

According to Theorem 1, if $w \in W_s$ (W_s is the set of stealthy words), we have $r = (b_a, \bar{b}_a)$ such that $\delta_{obs}^*(b_0, s) = b_a$, and $\delta_{obs}^*(b_0, \hat{P}(w)) = \bar{b}_a$, where \hat{P} is the operator mask. Note that, if $w \in W_e$ (W_e is the set of exposing words), then $\delta_a(r_0, w) = r = (b_a, b_\emptyset) \notin \mathcal{R}$, which leads to a contradiction. For this reason, we exclude such a case.

Since $r = (b_a, \bar{b}_a) \in \mathcal{R}$, then the observation s can be corrupted into a word $s' = \hat{P}(w)$ such that $(\mathcal{C}(s), \mathcal{C}(s')) \in \mathcal{R}$, where $\mathcal{C}(s) = \delta_{obs}^*(b_0, s)$, and $\mathcal{C}(s') = \delta_{obs}^*(b_0, s')$ ($\mathcal{C}(s)$ (resp., $\mathcal{C}(s')$) is the set of states consistent with observation s (resp., s')). According to Definition 6, we can conclude that f_n is harmful.

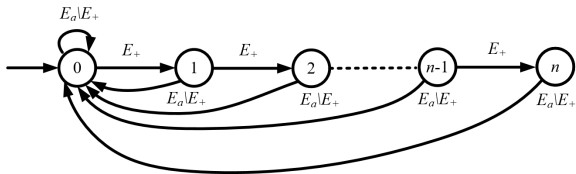

FIGURE 7. n -bounded attack automaton G_n .

(Only if) Assume that an attack function f_n is harmful. According to Definition 6, there exists an observation s that can be corrupted into an observation $s' = \hat{P}(w)$ such that $(\mathcal{C}(s), \mathcal{C}(\hat{P}(w))) \in \mathcal{R}$, where $\mathcal{C}(s) = \delta_{obs}^*(b_0, s)$, $\mathcal{C}(\hat{P}(w)) = \delta_{obs}^*(b_0, \hat{P}(w))$, and $w = f_n(s) \in W_s$ (we exclude the case that $w \in W_e$ for the same reason that discussed in the above proof).

Since the joint estimator A contains all the possible attacks, and according to Theorem 1, then there must exist a state $r = \delta_a(r_0, w) = (b_a, \bar{b}_a)$ such that $\delta_{obs}^*(b_0, s) = b_a$, and $\delta_{obs}^*(b_0, \hat{P}(w)) = \bar{b}_a$. Namely, $R \cap \mathcal{R} \neq \emptyset$. \square

Example 5: Recall the plant G in Fig. 4 with the unbounded joint estimator A_∞ depicted in Fig. 6. Assume that the misleading relation is $\mathcal{R} = \{(\{5\}, X) \mid X \subseteq \{6, 7, 8\}\}$.

Looking at A_∞ , if the plant generates the word aa , A_∞ is in state $(\{5\}, \{5\})$, then the attacker can insert a fake event c_+ such that state $(\{5\}, \{6\}) \in \mathcal{R}$ is reached. If such a state is reached, the plant is in the critical state $\{5\}$, while the operator thinks that the plant is in the non-critical state $\{6\}$. Thus no protective actions are activated, and damages are caused. \diamond

We conclude this subsection discussing the complexity of computing the unbounded joint estimator A_∞ .

Given a plant G with set of states X , both the attack observer and the operator observer are computed in $2^{|X|}$ steps. The unbounded joint estimator is defined as $A_\infty = Obs_{att}(G) \parallel Obs_{opr}(G)$; thus the complexity of constructing A_∞ is $O(2^{|X|} \cdot 2^{|X|})$.

B. BOUNDED JOINT ESTIMATOR

The n -bounded joint estimator A_n that describes attack functions in \mathcal{F}_n , can be easily obtained starting from A_∞ . To this aim, a particular DFA, called n -bounded attack automaton, denoted as G_n , is introduced. Then A_n is obtained as the concurrent composition of A_∞ and G_n .

Definition 10: The n -bounded attack automaton is a DFA: $G_n = (X, E_a, \delta, 0)$, where $X = \{0, 1, \dots, n\}$ ($n \in \mathbb{N}$), and the transition function is defined as follows:

$$\begin{cases} \forall i \in X, \delta(i, e_a) := 0 & \text{if } e_a \in E_a \setminus E_+, \\ \forall i \in (X \setminus \{n\}), \delta(i, e_a) := i + 1 & \text{if } e_a \in E_+. \end{cases} \quad (5)$$

Fig. 7 shows the n -bounded attack automaton G_n . As it can be seen, events in $E_a \setminus E_+$ are enabled at any state. On the contrary, events in E_+ are enabled provided that they have not been already executed n times consecutively.

Theorem 2: Let G be a plant with attack alphabet E_a and unbounded joint estimator $A_\infty = (R, E_a, \delta_a, r_0)$. Let $A_n = A_\infty \parallel G_n$, where G_n is the n -bounded attack automaton.

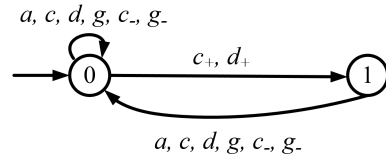

FIGURE 8. 1-bounded attack automaton G_1 in Example 6.

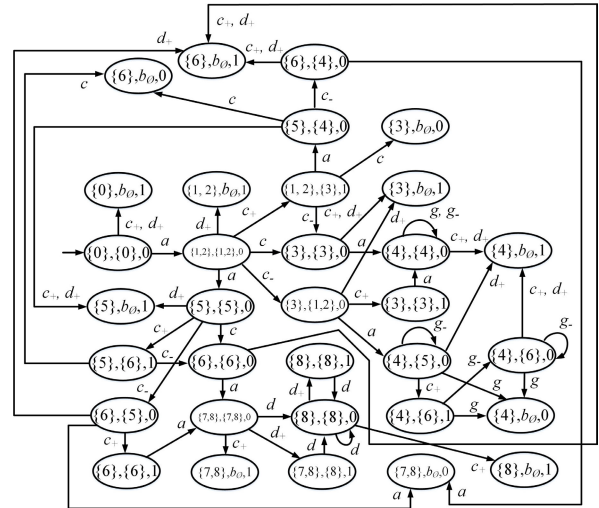

FIGURE 9. 1-bounded joint estimator A_1 in Example 6.

It holds that $L(A_n) = L(A_\infty) \setminus \{w \in L(A_\infty) \mid cons_{E_+}(w) > n\}$, where $cons_{E_+}(w)$ denotes the maximum number of consecutive events in E_+ contained in the word w .

Proof: Follows from the fact that A_n is defined as $A_n = A_\infty \parallel G_n$ and G_n limits to n the maximum number of consecutive events that the attacker can add to the operator observation. \square

Example 6: Consider the unbounded joint estimator A_∞ in Example 4. The 1-bounded attack automaton G_1 and the 1-bounded joint estimator $A_1 = A_\infty \parallel G_1$ are depicted in Figs. 8 and 9, respectively.

The 1-bounded joint estimator forces the attacker to insert at most one fake event between the occurrence of two observable events of the system. \diamond

A result equivalent to Theorem 1 holds for an n -bounded joint estimator.

Now we discuss the computational complexity of building the n -bounded joint estimator A_n . Given an integer value n , the n -bounded joint estimator is obtained by computing $A_n = A_\infty \parallel G_n$ where G_n is the n -bounded attack automaton. Therefore, the complexity of computing A_n is $O(2^{|X|} \cdot 2^{|X|} \cdot n)$.

VI. CONCLUSION AND FUTURE WORK

In this paper we investigate the problem of state estimation under attack, for partially-observed discrete event systems. In more detail, an operator observes the system evolution with a natural projection, which depends on the sensors available on the system. The operator observation may be corrupted by an attacker. The corruption may be done by erasing some events that have occurred and/or inserting some events that

have not actually occurred. It is possible to impose an upper bound on the number n of consecutive observations that can be added by the attacker within the occurrence of two observable events in the plant. We show how to construct a joint estimator that contains all the possible attacks that can be implemented during the system evolution and that allows to establish if an attack function is harmful w.r.t. a given misleading relation.

Our future lines of research in this framework will follow several directions. On the one hand, we will look for a way to select stealthy and harmful attacks on the basis of the joint estimator or establish if such attacks can be thwarted. On the other hand, we will try to characterize and solve the same problem using Petri nets to understand if some advantages in terms of computational complexity can be obtained and if efficient solutions can also be computed for unbounded systems.

REFERENCES

- [1] D. Zhang, G. Feng, Y. Shi, and D. Srinivasan, "Physical safety and cyber security analysis of multi-agent systems: A survey of recent advances," *IEEE/CAA J. Autom. Sinica*, vol. 8, no. 2, pp. 319–333, Feb. 2021.
- [2] A. Rashidinejad, B. Wetzels, M. Reniers, L. Lin, Y. Zhu, and R. Su, "Supervisory control of discrete-event systems under attacks: An overview and outlook," in *Proc. 18th Eur. Control Conf. (ECC)*, Napoli, Italy, Jun. 2019, pp. 1732–1739.
- [3] M. Uma and G. Padmavathi, "A survey on various cyber attacks and their classification," *Int. J. Netw. Secur.*, vol. 15, no. 5, pp. 390–396, Sep. 2013.
- [4] F. Salahdine and N. Kaabouch, "Social engineering attacks: A survey," *Future Internet*, vol. 11, no. 4, p. 89, Apr. 2019.
- [5] A. Basit, M. Zafar, X. Liu, A. R. Javed, Z. Jalil, and K. Kifayat, "A comprehensive survey of AI-enabled phishing attacks detection techniques," *Telecommun. Syst.*, vol. 76, no. 1, pp. 139–154, Jan. 2021.
- [6] X. Huang and J. Dong, "Reliable control policy of cyber-physical systems against a class of frequency-constrained sensor and actuator attacks," *IEEE Trans. Cybern.*, vol. 48, no. 12, pp. 3432–3439, Dec. 2018.
- [7] D. Rabehi, N. Meslem, and N. Ramdani, "Secure interval observer for linear continuous-time systems with discrete measurements subject to cyber-attacks," in *Proc. 4th Conf. Control Fault Tolerant Syst. (SysTol)*, Casablanca, Morocco, Sep. 2019, pp. 336–341.
- [8] H. Liu, B. Niu, and J. Qin, "Reachability analysis for linear discrete-time systems under stealthy cyber attacks," *IEEE Trans. Autom. Control*, vol. 66, no. 9, pp. 4444–4451, Sep. 2021.
- [9] W. Zhang, S. Mao, J. Huang, L. Kocarev, and Y. Tang, "Data-driven resilient control for linear discrete-time multi-agent networks under unconfined cyber-attacks," *IEEE Trans. Circuits Syst. I, Reg. Papers*, vol. 68, no. 2, pp. 776–785, Feb. 2021.
- [10] D. Thorsley and D. Teneketzis, "Intrusion detection in controlled discrete event systems," in *Proc. 45th IEEE Conf. Decis. Control*, San Diego, CA, USA, Dec. 2006, pp. 6047–6054.
- [11] F. A. Barbhuiya, M. Agarwal, S. Purwar, S. Biswas, and S. Nandi, "Application of stochastic discrete event system framework for detection of induced low rate TCP attack," *ISA Trans.*, vol. 58, pp. 474–492, Sep. 2015.
- [12] R. Fritz and P. Zhang, "Modeling and detection of cyber attacks on discrete event systems," in *Proc. 14th Int. Workshop Discrete Event Syst.*, Sorrento, Italy, 2018, pp. 285–290.
- [13] M. Agarwal, S. Biswas, and S. Nandi, "Discrete event system framework for fault diagnosis with measurement inconsistency: Case study of rogue DHCP attack," *IEEE/CAA J. Autom. Sinica*, vol. 6, no. 3, pp. 789–806, May 2019.
- [14] Y. Ji, X. Yin, and S. Lafortune, "Enforcing opacity by insertion functions under multiple energy constraints," *Automatica*, vol. 108, Oct. 2019, Art. no. 108476.
- [15] L. K. Carvalho, Y.-C. Wu, R. Kwong, and S. Lafortune, "Detection and mitigation of classes of attacks in supervisory control systems," *Automatica*, vol. 97, pp. 121–133, Nov. 2018.
- [16] P. M. Lima, M. V. S. Alves, L. K. Carvalho, and M. V. Moreira, "Security against network attacks in supervisory control systems," in *Proc. 20th IFAC World Congr.*, Toulouse, France, vol. 50, 2017, pp. 12333–12338.
- [17] M. Wakaiki, P. Tabuada, and J. P. Hespanha, "Supervisory control of discrete-event systems under attacks," *Dyn. Games Appl.*, vol. 9, no. 4, pp. 965–983, Dec. 2019.
- [18] L. Lin and R. Su, "Synthesis of covert actuator and sensor attackers," *Automatica*, vol. 130, Aug. 2021, Art. no. 109714.
- [19] R. Meira-Goes, S. Lafortune, and H. Marchand, "Synthesis of supervisors robust against sensor deception attacks," *IEEE Trans. Autom. Control*, vol. 66, no. 10, pp. 4990–4997, Oct. 2021, doi: 10.1109/TAC.2021.3051459.
- [20] Z. Jakovljevic, V. Lesi, and M. Pajic, "Attacks on distributed sequential control in manufacturing automation," *IEEE Trans. Ind. Informat.*, vol. 17, no. 2, pp. 775–786, Feb. 2021.
- [21] J. Yao, X. Yin, and S. Li, "On attack mitigation in supervisory control systems: A tolerant control approach," in *Proc. 59th IEEE Conf. Decis. Control (CDC)*, Jeju, South Korea, Dec. 2020, pp. 4504–4510.
- [22] Y. Wang and M. Pajic, "Supervisory control of discrete event systems in the presence of sensor and actuator attacks," in *Proc. IEEE 58th Conf. Decis. Control (CDC)*, Nice, France, Dec. 2019, pp. 5350–5355.
- [23] D. You, S. Wang, M. Zhou, and C. Seatzu, "Supervisory control of Petri nets in the presence of replacement attacks," *IEEE Trans. Autom. Control*, early access, Mar. 3, 2021, doi: 10.1109/TAC.2021.3063699.
- [24] S. Zheng, S. Shu, and F. Lin, "Modeling and control of discrete event systems under joint sensor-actuator cyber attacks," in *Proc. 6th Int. Conf. Automat., Control Robot. Eng. (CACRE)*, Dalian, China, Jul. 2021, pp. 216–220.
- [25] Y. Tong, Z. Ma, Z. Li, C. Seatzu, and A. Giua, "Supervisory enforcement of current-state opacity with uncomparable observations," in *Proc. 13th Int. Workshop Discrete Event Syst. (WODES)*, Xi'an, China, May 2016, pp. 313–318.
- [26] R. Meira-Góes, E. Kang, R. H. Kwong, and S. Lafortune, "Synthesis of sensor deception attacks at the supervisory layer of cyber-physical systems," *Automatica*, vol. 121, Nov. 2020, Art. no. 109172.
- [27] P. M. Lima, L. K. Carvalho, and M. V. Moreira, "Detectable and undetectable network attack security of cyber-physical systems," in *Proc. 14th Int. Workshop Discrete Event Syst.*, Sorrento, Italy, 2018, pp. 179–185.
- [28] R. Su, "Supervisor synthesis to thwart cyber attack with bounded sensor reading alterations," *Automatica*, vol. 94, pp. 35–44, Aug. 2018.
- [29] Q. Zhang, Z. Li, C. Seatzu, and A. Giua, "Stealthy attacks for partially-observed discrete event systems," in *Proc. IEEE 23rd Int. Conf. Emerg. Technol. Factory Automat. (ETFA)*, Turin, Italy, Sep. 2018, pp. 1161–1164.
- [30] K. Ding, Y. Li, D. E. Quevedo, S. Dey, and L. Shi, "A multi-channel transmission schedule for remote state estimation under DoS attacks," *Automatica*, vol. 78, pp. 194–201, Apr. 2017.
- [31] L. Peng, L. Shi, X. Cao, and C. Sun, "Optimal attack energy allocation against remote state estimation," *IEEE Trans. Autom. Control*, vol. 63, no. 7, pp. 2199–2205, Jul. 2018.
- [32] P. Cheng, Z. Yang, J. Chen, Y. Qi, and L. Shi, "An event-based stealthy attack on remote state estimation," *IEEE Trans. Autom. Control*, vol. 65, no. 10, pp. 4348–4355, Oct. 2020.
- [33] P. J. G. Ramadge and W. M. Wonham, "The control of discrete event systems," *Proc. IEEE*, vol. 77, no. 1, pp. 81–98, Jan. 1989.
- [34] C. Cassandras and S. Lafortune, *Introduction to Discrete Event Systems*, 2nd ed. New York, NY, USA: Springer, 2008.



QI ZHANG is currently pursuing the Ph.D. degree in control theory and control engineering with Xidian University, Xi'an, China, in co-tutorship with the Department of Electrical and Electronic Engineering, University of Cagliari, Italy.

His current research interests include automata theory, Petri nets theory, supervisory control of discrete event systems, and cyber security.



CARLA SEATZU (Senior Member, IEEE) received the master's degree in electrical engineering and the Ph.D. degree in electronic and computer engineering from the University of Cagliari, Cagliari, Italy, in 1996 and 2000, respectively.

She was a Visiting Professor in the universities at Zaragoza, Spain; Atlanta, GA, USA; Guadalajara, Mexico; Xi'an, China; and Hangzhou, China. She is currently a Full Professor in automatic control with the University of Cagliari. She is also a Coordinator of the B.Sc. degree in electrical, electronic, and computer engineering. She is the author of over 250 publications, including over 80 articles in international journals and one textbook. She is the editor of two international books. Her H-index in Scopus is equal to 33. Her research interests include discrete-event systems, Petri nets, hybrid systems, networked control systems, manufacturing, and transportation systems.

Dr. Seatzu was the Program Chair of the 23rd IEEE International Conference on Emerging Technologies and Factory Automation, in 2018, the Workshop Chair of the 55th IEEE Conference on Decision and Control, in 2016, and the General Co-Chair of the 18th IEEE International Conference on Emerging Technologies and Factory Automation, in 2013. She is an Editor of the IEEE TRANSACTIONS ON AUTOMATION SCIENCE AND ENGINEERING, an Associate Editor of the *Discrete Event Dynamic Systems* journal, and a Senior Editor of the IEEE CONTROL SYSTEMS LETTERS.



ZHIWU LI (Fellow, IEEE) received the B.S., M.S., and Ph.D. degrees in mechanical engineering, automatic control, and manufacturing engineering, respectively, from Xidian University, Xi'an, China, in 1989, 1992, and 1995, respectively.

He joined Xidian University, in 1992, and he is currently with the Institute of Systems Engineering, Macau University of Science and Technology, Taipa, Macau. Over the past decade, he was a Visiting Professor with the University of Toronto, Technion-Israel Institute of Technology, Martin-Luther University of Halle-Wittenberg, Conservatoire National des Arts et Métiers, Meliksah Universitesi, and King Saud University. His current research interests include Petri net theory and application, supervisory control of discrete event systems, workflow modeling and analysis, system reconfiguration, game theory, and data and process mining.



ALESSANDRO GIUA (Fellow, IEEE) received the Laurea degree from the University of Cagliari, Italy, in 1988, and the master's and Ph.D. degrees in computer and systems engineering from the Rensselaer Polytechnic Institute, Troy, NY, USA, in 1990 and 1992, respectively. He is currently a Professor in automatic control with the Department of Electrical and Electronic Engineering (DIEE), University of Cagliari. He has also held faculty or visiting positions in

several institutions worldwide, including Aix-Marseille University, France and Xidian University, Xian, China. His research interests include discrete event systems, hybrid systems, networked control systems, Petri nets, and failure diagnosis.

He is a member of the IEEE Control Systems Society, where he has served as the Vice President for Conference Activities (2020–2021), the General Chair of the 55th Conference on Decision and Control, in 2016, and a member of the Board of Governors (2013–2015). He is an affiliate of the International Federation of Automatic Control (IFAC), where he has served as the Chair of the IFAC Technical Committee 1.3 on Discrete Event and Hybrid Systems (2008–2014) and a member of the Publications Committee, since 2014. He is a fellow of the IFAC for contributions to Discrete Event and Hybrid Systems, and a recipient of the IFAC Outstanding Service Award. He received the People's Republic of China Friendship Award, in 2017. He is currently the Editor-in-Chief of the *Nonlinear Analysis: Hybrid Systems* IFAC journal and as a Senior Editor of the IEEE TRANSACTIONS ON AUTOMATIC CONTROL.

...