

Received September 11, 2021, accepted September 21, 2021, date of publication October 4, 2021, date of current version October 20, 2021.

Digital Object Identifier 10.1109/ACCESS.2021.3117928

Temperature and Reliability-Aware Routing Protocol for Wireless Body Area Networks

SAIFULLAH MEMON¹, JINGYU WANG¹, (Senior Member, IEEE), ALI RAZA BHANGWAR²,
SULIMAN MOHAMED FATI³, (Senior Member, IEEE), AMJAD REHMAN³, (Senior Member, IEEE),
TONG XU¹, AND LEI ZHANG¹

¹State Key Laboratory of Networking and Switching Technology, Beijing University of Posts and Telecommunications, Beijing 100876, China

²Department of Computer System Engineering, Quaid-e-Awam University of Engineering, Science and Technology, Nawabshah 67450, Pakistan

³Artificial Intelligence and Data Analysis Lab (AIDA), CCIS Prince Sultan University, Riyadh 11586, Saudi Arabia

Corresponding authors: Jingyu Wang (wangjingyu@bupt.edu.cn) and Saifullah Memon (memonsaifullah@bupt.edu.cn)

ABSTRACT The Wireless Body Sensor Network (WBSN) can be envisioned as a cost-effective solution to provide monitoring and reporting services in medical and non-medical applications to improve quality of life. The dissemination of patient data in a timely and reliable manner is one of the necessities of healthcare applications of WBSN. The critical data packets are highly delay-sensitive. However, these packets reaching the destination beyond timelines undermine the benefit of such networks. To provide real-time health monitoring an adequate link (in terms of reliability, stability, and QoS) has to be maintained. However, the distinguishing characteristics of WBSN pose several challenges to be countered such as limited resources, transmission range, and unreliable wireless links in terms of QoS as low-power radios are sensitive to interference and noise. Consequently, some portions of the network experience a significant level of congestion thereby strain the communication links, available bandwidth, insufficient buffer space, increased number of collisions, packet losses, and transmission disruption. Therefore, importing QoS awareness in routing decisions is important to improve the performance of WBSN. This paper proposes a QoS-aware routing protocol named TLD-RP (Temperature, Link-reliable, and Delay-aware Routing Protocol) for WBSN. Most of the temperature-aware routing protocols proposed for the WBSN incorporate either single or composite routing metrics (temperature, hop count, or energy). However, optimized route discovery has been overlooked in most of the previous studies on QoS requirements such as link reliability, stability, and link delay. Keeping in view these limitations, the proposed TLD-RP makes use of a multi-facet composite routing metric by carefully considering the critical QoS requirements for the WBAN. The design of the proposed TLD-RP scheme centers on the link's reliability, path delay, and link's asymmetric property. These design factors enable the proposed TLD-RP scheme to make more informed decisions regarding dynamic channel conditions. The optimized links satisfying the QoS requirements are selected for routing data packets. The simulation results confirm the effectiveness and efficacy of the proposed TLD-RP strategy by improving WBSN performance along with throughput, packet delivery, network overhead, and link stability.

INDEX TERMS Link quality, quality of service, routing protocol, temperature-awareness, wireless body sensor network.

I. INTRODUCTION

The technological advancement in wireless communication has made it possible to use Nano-sized biomedical sensor nodes in recording real-time data. The network of such Nano-sized biomedical sensor nodes mounted on the human body is called Wireless Body Area Network (WBAN) [1]. Usually,

The associate editor coordinating the review of this manuscript and approving it for publication was Matti Hämäläinen.

the sensor nodes mounted on different parts of the human body, tap patient's data for diagnosing the disease at their preliminary stages. However, modern applications of WBAN are not limited to a patient only. Today, WBANs are widely used to observe in real-time the performance of athletes and military personals on the battlefield.

The patient's data in a WBAN is wirelessly transmitted to a central location for diagnosis by a physician. Hence, data must reach reliably and safely at the end station. On the other

hand, wireless communication is traditionally error-prone. The loss of critical data packets might result in serious threats to the patient’s life. Therefore, WBAN needs some secure mechanism to safely transmit patient data to the end station. In wireless communication, among other factors, routing protocols play a key role in the fair utilization of network resources as well as the safe transmission of data packets within expected time bounds. However, routing protocols developed for other networks such as WSN and MANET cannot be used in their original form due to the unique challenges of WBANs [2]. Therefore, WBANs require the development of new routing protocols to meet its diverse challenges such as overheating, timely dissipation of critical data packets, network lifetime, and QoS requirements.

the rate of temperature rise around sensitive tissue [6] as represented in Equation 2.

$$\rho C_p \frac{dT}{dt} = K \nabla^2 T - b(T - T_b) + \rho SAR + P_c \quad (2)$$

where tissue’s specific heat is represented by C_p , the rate of temperature rise is represented by $\frac{dT}{dt}$, temperature rise due to thermal conductivity is represented by $K \nabla^2 T$, heat due to blood perfusion is represented by $b(T - T_b)$, the antenna radiation absorption is represented by ρSAR , whereas, the heat caused by the node circuitry is represented by P_c .

Moreover, healthcare applications of WBANs are inherently delay-sensitive and require disseminating critical data packets to the intended destination without any delay, as delayed packets could adversely affect the network performance [7]. Additionally, network nodes due to simultaneous data transmission and varying data rates might experience a significant level of congestion and link interference. Consequently, the wireless links between nodes frequently disconnect, therefore, consuming more network resources for re-establishing a new route.

The aforementioned constraints suggest that the routing protocols specifically designed for WBAN must have to address strict QoS Requirements. However, satisfying the QoS requirements of WBAN is quite a challenging task, since adequate link quality is a major demand to be maintained by the health monitoring services that work in real-time.

Therefore, it is an arduous and tiring job to design an efficient routing protocol having limited sorts of resources such as frequency, transmission-range, operating environment, data-rate, and low-power wireless links lacking reliability in terms of QoS requirements, since low power radios could highly be impaired to noise and interference [8].

Lately, various QoS-aware routing protocols/schemes have been suggested/proposed to address QoS challenges in WBAN. However, most of the routing protocols do not consider various design parameters for optimized route selection, therefore, result in degraded network performance in terms of high packet loss, higher end-to-end delay, and sensitive body tissue overheating [9]. Moreover, most of the routing schemes incorporate route-cost based on a single metric i.e. either (temperature, energy, or hop-count). However, from the relevant research, it has been revealed that end route selection based on only hop-count may not be an optimal solution, as selected routes might be experiencing high interference, delays, and loss ratio.

On the other hand, end route selection based on composite routing metric (i.e. temperature and energy, temperature and hop-count, energy and hop-count, or temperature, energy, and hop-count) for packet dissemination has been revealed to be a viable solution. However, most of the schemes based on composite routing metrics have overlooked QoS requirements for WBAN, thereby, unable to satisfy the QoS requirements for delay-sensitive applications of WBAN. The timely dissemination of critical data packets

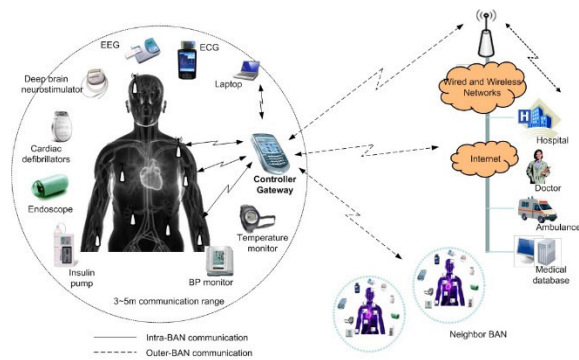

FIGURE 1. A typical architecture of a WBAN [3].

Fig. 1 shows the architecture of BAN where various physiological data could be collected from in or around the body to be transmitted to a Controller Gateway and further routed to Neighboring BAN or to the Internet backbone, which finally reaches the concerned entity [3]. Furthermore, in some situations, the implantation of biomedical sensor nodes is required to record physiological data. However, the human body absorbs radio signals which result in overheating of sensitive tissues around the sensor node. Tissue damage, due to implanted sensor nodes, could be the cause of prolonged radio communication. Therefore, protecting sensitive tissues from overheating, the extent of radiation absorption must be observed [4].

Human body tissues could absorb electromagnetic radiations and the rate at which they absorb is called Specific Absorption Rate (SAR). The measure of SAR per kilogram is given by Equation 1 [5].

$$SAR = \frac{\sigma |E^2|}{\rho} (W/kg) \quad (1)$$

where tissues’ electrical conductivity is represented by σ , E represents the electrical induced field. Whereas, the density of the tissue is represented by ρ .

In WBAN, there are mainly two main factors for tissue’s overheating, i.e. Radiations produced due to antenna and circuit of the node implanted inside the human body [1], [5]. A famous Penne’s bioheat equation is used to calculate

in delay-sensitive applications demands a more realistic solution. Therefore, QoS awareness in pursuit of link reliability and stability is an optimal solution for WBAN.

Therefore, this paper proposes a QoS-aware routing protocol named TLD-RP that makes more informed-decision about the route selection based on the link's reliability and its dynamic conditions (such as path delay and link's asymmetry property). Furthermore, this work is an extension of our previous work [2] which ensures reliable route selection to improve overall performance.

The proposed routing protocol incorporates a multi-facet composite routing metric that evaluates the route cost. The nodes satisfying the QoS requirements are selected in route discovery.

This paper makes the following contributions:

- We review state-of-art in broad areas of routing in WBAN and discuss the limitation being faced by existing routing schemes.
- The proposed routing scheme incorporates an exponential weighted moving average that makes a coherent decision for estimating long-term path delay.
- The proposed routing scheme evaluates the link reliability while catering to the dynamic conditions of link (link asymmetry) which makes a more informed decision regarding the path quality.
- The integrated outcome of these aforementioned QoS-aware metrics leads to the formation of an optimized composite routing metric. This multi-facet routing strategy helps in selecting routing paths that meet the QoS requirements of healthcare applications.

The ultimate part of the paper is organized in the following way. In Section II, we review the related works. Section III presents the details of the proposed routing scheme and algorithm. And Section IV presents the simulation results, comparative analysis, and result discussions. Finally, Section VI concludes the paper.

II. RELATED WORK

Lately, many routing protocols have been proposed to deal with the challenges and strict QoS requirements of the WBANs. These routing protocols are categorized as cross-layered routing, cluster-based routing, temperature-aware routing, and QoS-aware routing [1], [9], [10]. Primarily, the temperature-aware routing protocols are designed to overcome the temperature-rise around sensitive body tissues, caused by radio signals and power circuitry. The purpose of temperature-aware routing schemes is to minimize temperature-rise around biomedical sensor nodes by skillfully routing data from different routes, thereby, avoiding hotspot nodes (hotspot nodes are spotted when temperature values are exceeding a predefined threshold value). In continuation of improving the WBAN model by researchers, the first effort made to address the temperature rise issue was proposed in [11]. This scheme employs a technique of overhearing the transmission of neighboring nodes by calculating the load (packet sent and received)

which eventually helps to measure the temperature rise of a targeted node. The packets are withdrawn from the node whose temperature exceeds the threshold value until the temperature drops down to the normal value. In [12], a novel thermal and energy-aware routing (TEAR) protocol has been proposed for reliable data transmission in WBANs. The routing decisions are based on the weighted average of the cost function that is comprised of nodes' temperature, energy consumption, and link quality. The proposed protocol ensures reliable data forwarding to the sink node by evaluating link quality between communicating nodes thereby reducing the number of packet retransmissions which results in low energy consumption.

An adaptive thermal aware routing protocol (ATAR) for wireless body area networks has been proposed in [13] to reduce the average temperature rise of implanted biomedical sensor nodes in the WBAN. The proposed scheme focuses on reducing temperature rise by uniformly distributing the traffic load across the whole network. The temperature rise of implanted sensor nodes is addressed by using a multi-ring routing approach. Where source node adapts an alternative route if the temperature of any relay node along the active route at any specific time exceeds the threshold value.

In [14], a thermal-aware routing protocol has been proposed for WBANs. The data in this scheme has been assigned different priority levels, where high priority data is immediately forwarded to the sink node by ensures uniform distribution of temperature amongst all nodes in the network. A route cost metric has been defined which is based on the node's temperature, energy, and hop count. During the route establishment phase, the nodes satisfying the routing cost metric are elected for data forwarding.

A novel temperature-aware routing protocol [TA-IBN] for Intrabody Nano Network (IBN) has been proposed in [15], which addresses temperature-related constraints in IBN. The proposed routing scheme aims to stabilize the temperature across the network by reducing network congestion and preventing temperature rise in the hotspot region. Temperature rise in the network is controlled by avoiding packet forwarding and reception from heated regions. The result analysis confirms a steady temperature rise across the network as compared to other schemes.

In the recent past, various such temperature-aware routing schemes based on this principle have been proposed to overcome temperature-rise such as [5] [16]–[19]. However, the majority of the temperature-aware routing schemes suffer from high overhead, higher end-to-end delay, and quick depletion of nodes due to the excessive number of packet retransmissions.

Similarly, the second category, cluster-based routing, addresses the reduction of energy consumption. In this scheme, the whole network is divided into a smaller cluster of nodes with each cluster having a head node. This head node is chosen from each of the clusters to manage the entire traffic. Few very famous cluster-based routing schemes proposed in the last few decades are [20], [21]. However, cluster head

selection in these schemes contributes to huge overhead and higher average packet delivery delays.

The cross-layered routing scheme is another classification of routing protocols that eventually blends the challenges of both of them, the routing layer and medium access layer. These schemes achieve relatively high throughput and consume very low energy as compared to other schemes. However, cross-layered schemes are only suitable for immovable BANs. PCLRP, CLDO [22]–[24] and are very famous cross-layered routing protocols explicitly designed for WBANs.

Higher packet delivery ratio, lower end-to-end delay, and high reliability are the major factors kept in mind before designing the QoS-aware routing protocols. They are based on a modular approach where different modules are designed concerning different QoS parameters. The routing protocols which are designed using this approach mainly consist of a reliability-sensitive module, delay-sensitive module, power-efficiency module, and the neighbor-manager module. For the provision of strict QoS requirements, various QoS-aware routing protocols have been proposed for WBANs recently [19], [25]–[27].

A robust next-hop selection-based routing scheme named ENSA-BAN has been proposed in [28] to satisfy QoS requirements for WBANs. Data packets are forwarded via the best next-hop node to the sink node. Where the selection of the best next-hop node is based on both hop-counts and link cost of the neighboring nodes. The link cost of a neighboring node is evaluated by nodes’ residual energy, queue size, and link reliability. Each node in the network is required to select an efficient next-hop node having the least no. of hops to the sink node with a maximum value of the cost function.

The routing algorithm in this scheme works in two different phases i.e. a network initialization phase and a routing phase. In the network initialization phase, each node periodically broadcasts a hello packet by appending information about its residual energy, queue size, and no of hops to the sink node. A node upon receiving the hello packet constructs its neighbor table by updating information received in the hello packet. In the routing phase, the source node forward data packets via selected next-hop towards the sink node. The performance of the ENSA-BAN is evaluated in terms of energy consumption, packet forwarding ratio, and end-to-end delay. The authors claim significant performance improvement against the compared scheme. However, incorporating a hop-count scheme in delay-sensitive applications of WBANs may not be an optimal solution. A node in the shortest route to the sink node might be experiencing a high level of congestion and interference and could result in degraded performance.

Another approach to ensure the quality of service in WBANs is to assign priorities to different types of data packets. In [29], a priority-aware routing protocol named (P-AODV) has been proposed to enhance the QoS requirements for Adhoc networks. P-AODV ensures the QoS by maintaining different flows and assigned priorities to each

flow based on their data rate. Similarly, authors in [30], proposed a low latency traffic prioritization scheme (LLTP-QoS) for WBANs that ensures the transmission of critical data packets at the end station by avoiding node and link-level congestion.

The end-route selection in various QoS-aware schemes is based on a composite routing metric that is mainly comprised of temperature, energy, and hop-count. However, the routing metric in most of these schemes does not consider varying traffic and channel conditions, thereby, selecting inappropriate links that end up in poor QoS requirements. On the other hand, channel interference is one of the bottlenecks in QoS-aware routing that severely affects the performance of the network in respect of delay, reliability, and throughput [9], [31]. Therefore, most of these schemes suffer from an excessive number of packet retransmissions.

TABLE 1. Summary table.

Paper	Protocol Design	Path Quality	Link Delay	LAS Property	Route Maintenance
[11]	Temperature-Aware	×	×	×	Standard
[12]	Temperature-Aware	√	×	×	Standard
[13]	Temperature-Aware	×	×	×	Standard
[14]	Temperature-Aware	×	×	×	Standard
[15]	Temperature-Aware	×	×	×	Standard
[5]	Temperature-Aware	×	×	×	Standard
[16]	Temperature-Aware	×	×	×	Customized
[17]	Temperature-Aware	×	×	×	Standard
[18]	Temperature-Aware	√	×	×	Standard
[19]	Temperature & QoS-aware	×	√	×	Standard
[20]	Cluster Based	√	×	×	Standard
[21]	Cluster Based	×	×	×	Standard
[22]	Cross Layer	×	×	×	Standard
[23]	Cross Layer	√	×	×	Standard
[24]	Cross Layer	√	×	×	Standard
[25]	QoS-aware	×	√	×	Standard
[26]	QoS-aware	√	×	×	Standard
[27]	QoS-aware	√	×	×	Standard
[28]	QoS-aware	√	×	×	Standard
[29]	QoS-aware	×	×	×	Standard
[30]	QoS-aware	√	√	×	Customized
Proposed Protocol	QoS-Aware	√	√	√	Customized

Table 1 provides the summary and comparison of the related work. Each scheme is compared in terms of related QoS parameters such as protocol design, path quality, link delay, Link Asymmetric (LAS) property, and route

maintenance. The literature review discussed above suggests that addressing strict QoS requirements concerning channel conditions and variable traffic is quite a challenging task. While bearing these issues and constraints in mind, we are proposing a QoS-aware routing protocol for WBANs that incorporates link reliability, link delay, and node temperature for end-route selection.

III. PROPOSED ROUTING SCHEME

In this section, we present a detailed overview of the proposed routing scheme named TLD-RP. The proposed routing scheme, TLD-RP, is an integrated outcome of three related modules such as *temperature awareness*, *path-delay estimation*, and *link reliability*. These factors are crucial for the delay-sensitive applications of WBAN. The routing mechanism of the TLD-RP scheme is based on the AODV routing protocol in which control packets for the route request (RREQ) and route reply (RREP) have been customized to incorporate related information such as temperature, link-reliability, and aggregated path delay. Moreover, the overall working of the proposed routing scheme is divided into the following operational phases.

(1) *Network initialization phase*, (2) *QoS-aware routing phase*, and (3) *Route maintenance Phase*. The subsequent section presents the details of these phases. Fig. 2 shows the research framework of the proposed TLD-RP scheme.

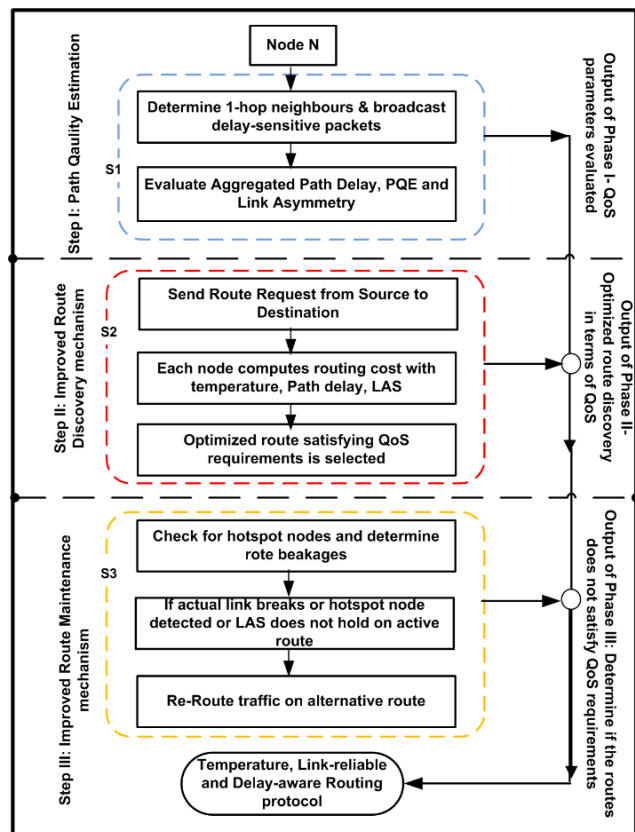

FIGURE 2. A framework of the proposed scheme.

A. NETWORK INITIALIZATION PHASE

In this phase, every sensor node broadcasts a HELLO packet (termed as a customized delay-sensitive packet) to determine neighboring nodes in their transmission range. A node that receives the HELLO packet appends/updates its relevant information (i.e. Aggregated Path-Delay and Link-Reliability) and rebroadcasts it to their neighboring nodes. This strategy continues until and unless every node in the network is determined. The computation of the aggregated path delay and link reliability is explained in the following subsection.

1) AGGREGATED PATH DELAY (APD)

For delay-sensitive applications, path delay plays a critical role. The information must have to be exchanged through optimal links involving the least delay. The information received beyond the specified time limit is useless and could bring a harmful impact on the patient's monitoring parameters. The biomedical sensor nodes in the network periodically exchange the delay-sensitive control packets termed as $Link_Delay_{x,y}$ for the $Link_{x,y}$. The link delay cost at node $Node_x$ over the link to the neighbor $Node_y$, $Link_Delay_{x,y}$ is evaluated using the elapsed time when $Node_x$ receives an acknowledgment from $Node_y$ as a response of transmitted delay-sensitive control packet (from $Node_x$). By considering the long-lasting performance of delay packets, $Link_Delay_{x,y}$ utilizes an exponential weighted moving average scheme [28], [32] as depicts in Equation-3. The equation illustrates that the value of $Link_Delay_{x,y}$ depends on the recent observation as well as the long-term average observed so far. We use $\alpha = 0.25$ to reduce the variations in the value of $Link_Delay_{x,y}$ so that it is a good representative of the long-term average.

$$Link_Delay_{x,y} = (1 - \alpha) \times Link_Delay_{x,y}^{t-1} + \alpha \times Link_Delay_{x,y}^t \quad (3)$$

The overall path delay (x, y) is computed as an aggregated sum of individual link-delay over all the links along the path, as shown in Equation-4.

$$Path_{Delay_{x,y}} = \sum_{\forall(y,z) \in \text{links along the path}} Link_Delay_{y,z} \quad (4)$$

2) PATH QUALITY ESTIMATOR (PQE)

In WBAN, communications links experience quality fluctuations and weak connectivity due to the use of low-power radios. These low-power radios are sensitive to interference, channel distortion and noise thereby leads to link instability and unreliability [33]. Therefore, incorporating path quality estimation in the design of routing protocol significantly improves the performance of routing protocols. The proposed routing protocol, TLD-RP, incorporates PQE as a fundamental QoS parameter thereby leads to the selection of stable and reliable routes for data delivery. Moreover, also brings several advantages such as improves the probability of message delivery (especially end-to-end), minimizes the

route re-discovery operation, and avoid re-transmissions over low-quality links.

The Path Quality Estimator (link's reliability) refers to the Packet Reception Ratio (PRR) or capacity of the link between two nodes $Node_i$ and $Node_j$. It is computed as the ratio of successfully received packets to the total number of transmitted packets (including the number of retransmitted packets), as shown in Equation-5.

$$PQE_{i,j} = \sum_{\forall(j,k) \in \text{all links}} PRR_{j,k} \quad (5)$$

The communication links in WBAN hold the asymmetric property, where the quality of the uplink and downlink is dynamic and varies with time. This is because nodes do not have the same reception sensitivity, interference factors, and transmission power. Thus, the quality of links estimated in a single direction does not yield precise values for the link's quality. The proposed TLD-RP routing protocol takes this limitation in viewpoint and incorporates Link ASymmetry (LAS) property by estimating the difference between uplink PQE and downlink PQE as shown in Equation-6. When the quality of the downlink is high as compared to the uplink, an error-free and successfully received packet may or may not be acknowledged after several re-transmissions. This effect is captured by LAS which could not be detected by $PQE_{i,j}$ alone.

$$LAS = |PQE_{uplink} - PQE_{downlink}| \quad (6)$$

To avoid data forwarding to a hotspot node (a node whose temperature exceeds the predefined threshold value), the temperature of each relay node is estimated by counting the total number of packets forwarded. However, we assume that each forwarded packet contributes to the temperature rise by one unit, and a threshold value i.e. 5 °C is set to declare a node as a hotspot node, as mentioned in [5]. A relay node can only participate in packet forwarding if its temperature remains below the threshold value.

Finally, the integrated outcome of temperature awareness (Temperature for the $Node_i$), along with the $Path Delay_{i,j}$, $PQE_{i,j}$ and LAS leads to the development of an optimized routing metric as mentioned in Equation-7.

$$RoutingMetric = \sum_{link \in r} (Temp_i + Path Delay_{i,j} + LAS) \quad (7)$$

B. QoS-AWARE ROUTE DISCOVERY PHASE

QoS-aware route discovery phase outstretches the route discovery strategy of traditional Adhoc On-demand Distance Vector (AODV) routing protocol by replacing hop-count metric with routing-metric as depicted in Equation-5 for determining optimized end-to-end routes. The network model of the proposed scheme is comprised of three different types of nodes (i.e. relay nodes, biomedical sensor nodes, and a gateway node). Equation-8 shows the connectivity graph of the proposed model.

$$CG = (V, E, W) \quad (8)$$

where, V , represents the total no. of relay nodes and biomedical sensor nodes such that $V = \{B_s\} U \{R_n\}$. $B_s = \sum (b_{s1}, b_{s2}, b_{s3}, b_{s4} \dots b_{sn})$, $R_n = \sum_{i,j} (r_1, r_2, r_3, r_4 \dots r_n)$. The links between relay, biomedical sensor node, and the gateway node are represented by E such that $E = \sum (e_1, e_2, b_3, b_4 \dots b_n)$ and the link metric is represented by W .

The source node upon having data packets looks for the route entry in its routing table for the destination node. If such a route exists in the routing table, the source node sends data packets immediately otherwise, the source node broadcasts a Route Request (RREQ) packet toward downstream nodes. The process continues until the RREQ reaches the destination node as shown in Fig. 3.

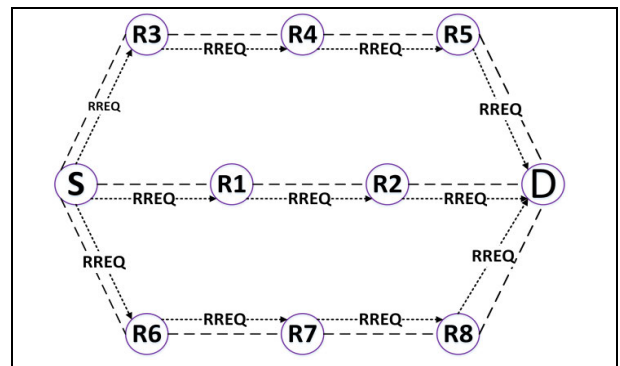

FIGURE 3. Route request process.

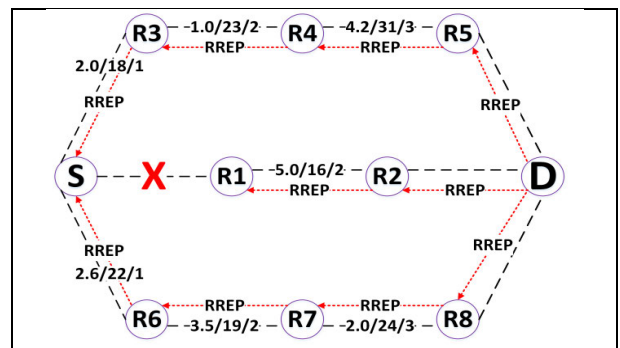

FIGURE 4. Route reply process.

The destination node unicasts Route Reply (RREP) packet in reverse direction towards the upstream node as shown in Fig. 4.

Ultimately, every intermediate relay node along with the reverse route updates the RREP packet by appending path-delay, temperature, path-quality estimator, and link asymmetry values in a customized RREP packet. However, the route reply from the node with high temperature referred to as hotspot node (i.e. the node having a temperature above the threshold value) is discarded along with the reverse route formation. Finally, the source node computes the route cost of various routes and determines the efficient

route based on the composite routing metric as shown in equation-7. Algorithm-1 further elaborates the QoS-aware route discovery phase of the proposed routing scheme.

Algorithm 1 TLD-RP Route Discovery Mechanism

```

1: Input:  $Path_{Delay_{x,y}}, PQE_{i,j}, Temp_{i,j}$ 
2: Output:  $Link_{i,j}$  QoS-aware link satisfying requirements in cost function.
3: BEGIN
4: Initialize Route Discovery
5: // Whether this is the route (meeting requirements) to destination
6: If (such route exist) then
7:   forward data packets
8: else
9:   call procedure RREQ_PROC
10: end if
11: _____
12: procedure RREQ_PROC
13:   Initialize RREQ Packets
14:    $RREQ \leftarrow$  Network Diameter
15:   Set  $Node_{curr} \leftarrow$  This_Node
16:   Set  $Node_{prev} \leftarrow \emptyset$ 
17:   Broadcast RREQ packets to downstream nodes
18:    $Node_{prev} \leftarrow Node_{curr}$ 
19:    $Node_{curr} \leftarrow$  This_Node
20: if  $Node_{this-node} = DestinationNode$  then
21:   call procedure RREP_PROC
22: end if
23: end proc
24: _____
25: procedure RREP_PROC
26:   Initialize RREP Packet
27:   Set  $Temp_{thresh} \leftarrow$  Temperature threshold
28:   Set  $PRR \leftarrow$  Packet Reception Ratio
29:   Set  $Link\_Delay \leftarrow$  Delay for each link
30:   Set  $PQE \leftarrow$  Path Quality Estimator
31:    $RREP_{Temp} \leftarrow \emptyset, RREP_{LAS} \leftarrow \emptyset, RREP_{Path\_delay} \leftarrow \emptyset,$ 
32:   Unicast RREP packet to upstream nodes
32:    $Node_{prev} \leftarrow Node_{curr}$ 
34:    $Node_{curr} \leftarrow$  This_Node
35:   Evaluate  $Path\_Delay, PQE,$  and  $LAS$  in Network Diameter at time  $t$ 
36:   Evaluate Temperature of Nodes in Network Diameter at time  $t$ 
37:    $T^t(x, y) = \left(1 - \frac{\Delta t b}{\rho C_p} - \frac{4\Delta t K}{\rho C_p \Delta^2}\right) T^{t-1}(x, y) + \frac{\nabla^t SAR}{C_p} + \frac{\Delta t b}{\rho C_p} T_b + \frac{\Delta}{\rho C_p} P_c + \frac{\Delta t K}{\rho C_p \Delta^2} (T^{t-1}(x+1, y) + T^{t-1}(x, y+1) + T^{t-1}(x-1, y) + T^{t-1}(x, y-1))$ 
38:   if  $T_{Node-prev} > Temp_{thresh}$  then
39:      $Node_{prev} \leftarrow Hotspot\_Node$ 
40:     Suspend this node for the predetermined time period
41:     Discard  $RREP_{node-prev}$ 
42:   end if
43:   if  $Node_{curr} = SourceNode$  then

```

```

44:   Compute  $Routing\_Metric$  from the Received RREP Packets
45:    $Routing\_Metric = RREP_{Temp} + RREP_{Path\_Delay} + RREP_{LAS}$ 
46:   if  $Routing\_Metric_{curr} < Routing\_Metric_{prev}$  then
47:     Update  $Routing\_Metric_{curr}$  for the route in cache
48:   end if
49:   Update  $RREP_{Temp}, RREP_{LR}, RREP_{LDE}$ 
50: end procedure RREP_PROC
51: END

```

C. ROUTE MAINTENANCE PHASE

Most of the multi-hop routing protocols rely on the route maintenance phase for reproofing link failure or route breakages. The proposed routing protocol TLD-RP also employs a customized route maintenance phase that initiates a new route discovery if any of the following events has occurred: hotspot node detected (node's temperature rises beyond specified threshold), due to channel diversity and dynamic conditions of the link LAS equation does not satisfy the QoS requirements and permanent failure of the active link. In either of the case, the intermediate node broadcasts the Route Error (RERR) packet to upstream nodes. The reporting node, all intermediate nodes on the active route, and source node declare that route as an invalid route and re-initiates the route discovery process. Fig. 5 shows the route maintenance process of the proposed scheme. The node R8 (in red color) finds that its temperature has surpassed the specified threshold value, therefore, it generated a RERR packet and forward it to its upstream nodes (R7, R6, and source nodes). The source node on receiving the RERR packet mark that route as broken or route failure and calls route discovery procedure.

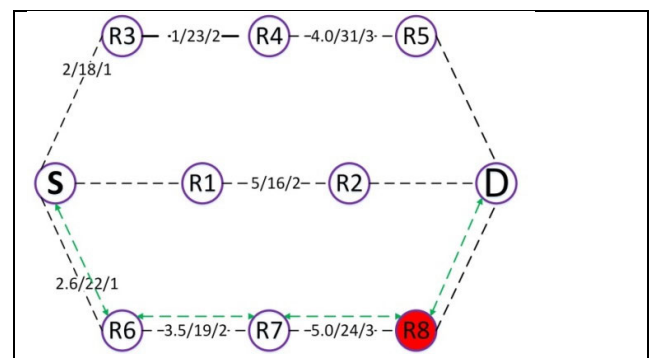

FIGURE 5. Route maintenance process.

IV. SIMULATION AND RESULT DISCUSSION

The simulation results are obtained using network simulator NS-2. The proposed scheme TLD-RP is compared against ENSA-BAN and P-AODV routing protocols of WBANS. The simulation results are evaluated in terms of packet drop ratio, throughput, routing overhead, and end-to-end delay. The simulation parameters are listed in Table 2.

TABLE 2. Simulation parameters.

Parameters	Values
Area	2m x 2m
Simulation time	1000 sec
No. of Relay nodes	12
No. of Sensor nodes	05
No. of Sink nodes	01
Transmission range	50cm
Traffic type	CBR
Transport layer protocol	UDP
Traffic load	50Kbps – 250Kbps
MAC layer Protocol	IEEE 802.15.4
Routing protocol	TLD-RP, ENSA-BAN, P-AODV

A. SIMULATION SCENARIO

The network topology includes 12 relay nodes, 05 sensor nodes, and a sink node, deployed within an area of 2m x 2m having a sensing range of 50cm. The sensor nodes are responsible for gathering the patient’s vital signs, relay nodes are responsible for routing the data to the sink node. The sink node is responsible for aggregating the received data and forward it to medical teams for monitoring and analyzing purposes. The performance of the proposed TLD-RP routing protocol is evaluated under a simulation scenario where traffic load is varied from 50Kbps to 250kbps. As we increase the traffic load that is the data rate of the flows, also strains some of the channels in the network. Therefore, varying the traffic load fairly analyzes the performance of QoS factors being used in the design of the proposed scheme such as Path delay, PQE, and Link Asymmetry. The performance of the proposed TLD-RP scheme is evaluated against ENSA-BAN and P-AODV routing schemes. Both of the routing protocol ENSA-BAN and P-AODV falls under the same category of a routing protocol as of proposed TLD-RP scheme i-e on-demand routing protocol. Moreover, the design of the cost function of all these three protocols centers on QoS awareness. Therefore, ENSA and P-AODV protocols have been chosen for performance comparison. The performance is evaluated in terms of Throughput, average end-to-end delay, Normalized routing load (NRL), and packet drop ratio. The *throughput* reflects the efficiency of the network in collecting and delivering data. It is defined as the aggregate data rate achieved in Kb/s at the destination nodes for all the flows in the network. One of the key desirable goals of the proposed scheme is to achieve high throughput performance. The average delay of the packets for all the flows is termed *average end-to-end delay*. Minimizing the end-to-end delay is also the desired goal of the proposed scheme. *The Normalized Routing Load (NRL)*, also termed as *Normalized Routing Overhead*, refers to the ratio of the total number of transmitted control packets to the successfully received data packets. The performance of NRL is an important indicator to determine the overall overhead involved in routing data packets. The *packet drop ratio* refers to the ratio of the total number

of dropped data packets to the total number of sent data packets.

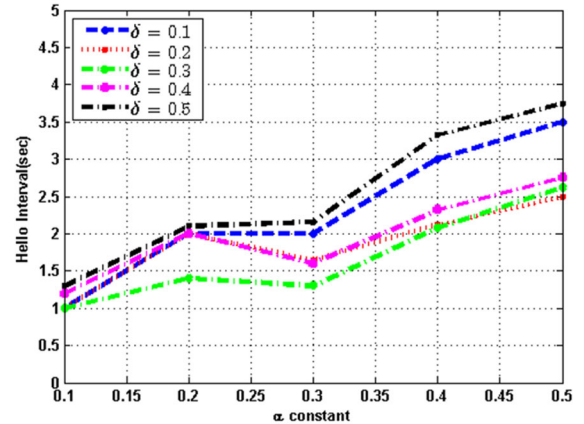

FIGURE 6. Analysis between hello internal and alpha constant.

B. PERFORMANCE EVALUATION

This section presents the simulation results and discusses the performance of proposed schemes against state-of-art under varying network traffic. Fig. 6 shows the sensitivity analysis between the alpha (alpha constant) and hello interval (in seconds). The value of alpha is varied from 0.1 to 0.5. The alpha is tuneable parameter which impact on the hello interval. It is observed that if the value of alpha is increased the hello interval also increases. The value of from 0.2 to 0.3 shows the optimized value of hello interval. Therefore, for the rest of result analysis the value of alpha is chosen as 0.25. Fig. 7 shows the performance of packet drop ratio at various network loads. It can be observed that at a low data rate, each scheme behaves almost similarly. However, packets are dropped at a significant level when the data rate is increased up to 250kb/s. Both the scheme P-AODV and ENSA-BAN, do not adapt to the varying channel conditions thereby results in increased packet losses at higher data rates. However, the proposed TLD-RP scheme makes use of a path quality estimator in routing decisions, therefore, the graph depicts that the proposed scheme outperforms the ENSA-BAN and P-AODV.

Fig. 8 shows the average throughput at various network loads. Throughput, increases with the increasing data rate, as the greater number of packets are provided to the network. The greater the number of packets the higher the throughput. However, at some point throughput starts declining since more network loads strain wireless links. It can be observed from Fig. 8 that with the gradual increase in data rate, throughput also increases in all the schemes. At lower data rates (50 Kbps – 100 Kbps) ENSA-BAN, P-AODV, and TLD-RP exhibit similar performance. However, the difference becomes significant at higher data rates. ENSA-BAN and P-AODV rely on hop count and priority queues for routing packets. These schemes do not provide any mechanism to deal with channel conditions such as link’s symmetry

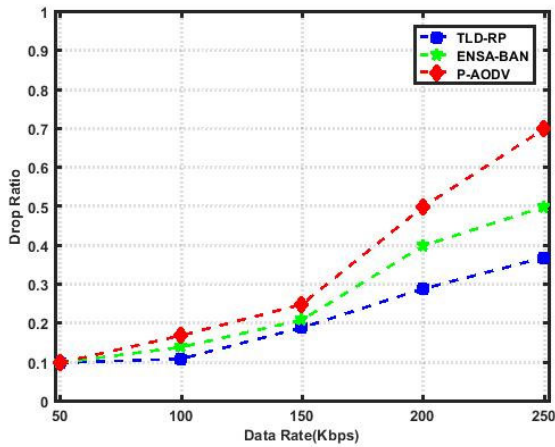

FIGURE 7. Analysis of packet drop ratio.

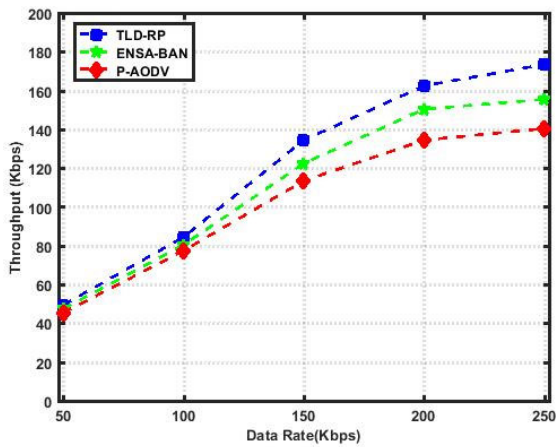

FIGURE 8. Analysis of average throughput.

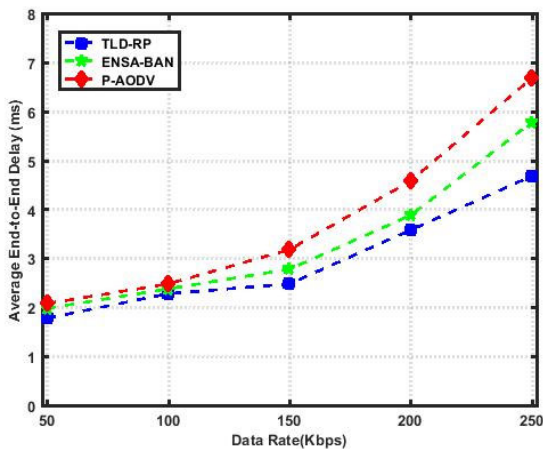

FIGURE 9. Analysis of average end-to-end delay.

property, delay, and quality. Therefore, ENSA-BAN and P-AODV result in decreased throughput performance. On the other hand, throughput in the proposed TLD-RP scheme is significantly higher than the compared schemes due to the selection of efficient and less congested links. Moreover, the multi-facet routing metric (PQE and path delay) helps

the proposed scheme in the selection of stable links which keeps the data flow consistent.

Fig. 9 shows the performance comparison of ENSA, PA-ADOV, and TLD-RP schemes in terms of average end-to-end delay at varying network loads. One of the desired goals of the TLD-RP scheme is to minimize the delay to route critical data packets, therefore, the design of TLD-RP schemes also centers on aggregated path Delay (APD) which makes a more informed decision regarding the path delay of each link. Therefore, the link with the minimum delay and high reliability will be selected. However, ENSA-BAN and P-AODV mostly rely on shortest and prioritized routes regardless of the link's condition and do nothing to optimize route selection by keeping link variations in view. Moreover, the increased number of retransmissions and route maintenance calls under heavy load also contribute to the declined end-to-end delay performance as packet forwarding is suspended till new routes are discovered.

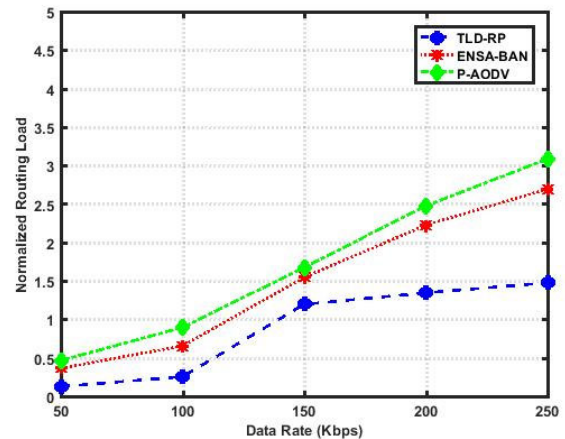

FIGURE 10. Analysis of normalized routing load.

Fig. 10 depicts the performance of normalized routing load. In the existing ENSA-BAN and P-AODV schemes, as the network load increases in the network, it also increases the interference in the network. This leads to transmission disruption and an increased number of packet drops and retransmission. Moreover, it also increases the route breakages and route maintenance calls. The increased number of route maintenance calls flood the network with control packets (RREQ, RREP, and RERR packets). As more control packets flow in the network it also increases the overhead of the routing protocols. Therefore, both of the schemes ENSA-BAN and P-AODV exhibit declined NRL performance. On the other hand, the proposed routing protocol TLD-RP maintains link stability and reliability. Moreover, the customized route maintenance scheme of the proposed scheme also makes a more informed decision about the actual link breakages thereby minimizes the retransmissions and new route discoveries. Consequently, the flow of control packets is kept low and the flow of data

packets remains consistent, therefore NRL performance is improved.

The simulation results will help design an improved routing protocol for delay-sensitive healthcare applications of WBAN. The design of the proposed routing protocol centers upon minimizing the delay in routing critical data packets.

V. CONCLUSION

The paper has presented an improved QoS and temperature-aware routing protocol for time-critical multi-hop WBAN. The proposed TLD-RP protocol picks the optimal path up based on path delay, link reliability (PQE), and link asymmetric property. The route qualifying the QoS requirements of WBAN is selected for forwarding packets. The performance of the TLD-RP protocol is evaluated against state-of-art schemes (ENSA-BAN and P-AODV) under varying traffic loads. The result analysis has demonstrated that the proposed scheme attains improved performance in terms of throughput, delivery ratio, delay, routing load, and loss ratio. The future work focuses on designing an improved QoS-aware routing protocol for postural body movements.

ACKNOWLEDGMENT

The authors are thankful to the State Key Laboratory of Networking and Switching Technology, Beijing University of Posts and Telecommunication (BUPT), Beijing, China, and Prince Sultan University Saudi Arabia for collaboration in this work. They are also thankful to Prince Sultan University for paying the Article Processing Charges (APC) of this publication.

REFERENCES

- [1] S. Movassaghi, M. Abolhasan, J. Lipman, D. Smith, and A. Jamalipour, "Wireless body area networks: A survey," *IEEE Commun. Surveys Tuts.*, vol. 16, no. 3, pp. 1658–1686, 3rd Quart., 2014.
- [2] A. R. Bhangwar, A. Ahmed, U. A. Khan, T. Saba, K. Almufatah, K. Haseeb, and N. Islam, "WETRP: Weight based energy & temperature aware routing protocol for wireless body sensor networks," *IEEE Access*, vol. 7, pp. 87987–87995, 2019.
- [3] M. A. Ameen and C. Hong, "An on-demand emergency packet transmission scheme for wireless body area networks," *Sensors*, vol. 15, no. 12, pp. 30584–30616, Dec. 2015.
- [4] M. Javed, G. Ahmed, D. Mahmood, M. Raza, K. Ali, and M. Ur-Rehman, "TAE0—A thermal aware & energy optimized routing protocol for wireless body area networks," *Sensors*, vol. 19, no. 15, p. 3275, Jul. 2019.
- [5] S. Movassaghi, M. Abolhasan, and J. Lipman, "Energy efficient thermal and power aware (ETPA) routing in body area networks," in *Proc. IEEE Int. Symp. Pers. Indoor Mob. Radio Commun. (PIMRC)*, vol. 13, no. 3, Nov. 2012, pp. 1108–1113.
- [6] J. I. Bangash, A. H. Abdullah, M. A. Razzaque, and A. W. Khan, "Reliability aware routing for intra-wireless body sensor networks," *Int. J. Distrib. Sensor Netw.*, vol. 10, no. 10, Oct. 2014, Art. no. 786537.
- [7] C. Yi and J. Cai, "Transmission management of delay-sensitive medical packets in beyond wireless body area networks: A queueing game approach," *IEEE Trans. Mobile Comput.*, vol. 17, no. 9, pp. 2209–2222, Sep. 2018.
- [8] A. Ahmed, I. A. Halepoto, U. A. Khan, S. Kumar, and A. R. Bhangwar, "I-RP: Interference aware routing protocol for WBAN," in *Mobile Web and Intelligent Information Systems*, vol. 10995. Cham, Switzerland: Springer, 2018, pp. 63–71.
- [9] S. Movassaghi, M. Abolhasan, and J. Lipman, "A review of routing protocols in wireless body area networks," *J. Netw.*, vol. 8, no. 3, pp. 559–575, 2013.
- [10] L. Filipe, F. Fdez-Riverola, N. Costa, and A. Pereira, "Wireless body area networks for healthcare applications: Protocol stack review," *Int. J. Distrib. Sensor Netw.*, vol. 2015, pp. 1–23, Oct. 2015.
- [11] Q. Tang, N. Tummala, S. K. S. Gupta, and L. Schwiebert, "TARA: Thermal-aware routing algorithm for implanted sensor networks," in *Proc. 1st IEEE Int. Conf. Distrib. Comput. Sensor Syst.*, Jun. 2005, pp. 206–217.
- [12] G. Ahmed, D. Mahmood, and S. Islam, "Thermal and energy aware routing in wireless body area networks," *Int. J. Distrib. Sensor Netw.*, vol. 15, no. 6, Jun. 2019, Art. no. 155014771985497.
- [13] F. Jamil, M. A. Iqbal, R. Amin, and D. Kim, "Adaptive thermal-aware routing protocol for wireless body area network," *Electronics*, vol. 8, no. 1, p. 47, Jan. 2019.
- [14] K. S. Kathe and U. A. Deshpande, "A thermal aware routing algorithm for a wireless body area network," *Wireless Pers. Commun.*, vol. 105, no. 4, pp. 1353–1380, Apr. 2019.
- [15] S. Javaid, Z. Wu, Z. Hamid, S. Zeadally, and H. Fahim, "Temperature-aware routing protocol for intrabody nanonetworks," *J. Netw. Comput. Appl.*, vols. 183–184, Jun. 2021, Art. no. 103057.
- [16] A. R. Bhangwar, P. Kumar, A. Ahmed, and M. I. Channa, "Trust and thermal aware routing protocol (TTRP) for wireless body area networks," *Wireless Pers. Commun.*, vol. 97, no. 1, pp. 349–364, Nov. 2017.
- [17] S. Jain and A. Singh, "Temperature-aware routing using secondary sink in wireless body area sensor network," *Int. J. E-Health Med. Commun.*, vol. 9, no. 2, pp. 38–58, Apr. 2018.
- [18] B.-S. Kim, B. Shah, F. Al-Obediat, S. Ullah, K. H. Kim, and K.-I. Kim, "An enhanced mobility and temperature aware routing protocol through multi-criteria decision making method in wireless body area networks," *Appl. Sci.*, vol. 8, no. 11, p. 2245, 2018.
- [19] M. Monowar and F. Bajaber, "On designing thermal-aware localized QoS routing protocol for in-vivo sensor nodes in wireless body area networks," *Sensors*, vol. 15, no. 6, pp. 14016–14044, Jun. 2015.
- [20] Z. Ullah, I. Ahmed, K. Razzaq, M. K. Naseer, and N. Ahmed, "DSCB: Dual sink approach using clustering in body area network," *Peer-Peer Netw. Appl.*, vol. 12, no. 2, pp. 357–370, 2017.
- [21] B. Abidi, A. Jilbab, and E. H. Mohamed, "An energy efficiency routing protocol for wireless body area networks," *J. Med. Eng. Technol.*, vol. 42, no. 4, pp. 290–297, May 2018.
- [22] H. B. Elhadj, J. Elias, L. Chaari, and L. Kamoun, "A Priority based cross layer routing protocol for healthcare applications," *Ad Hoc Netw.*, vol. 42, no. 5, pp. 1–18, 2016.
- [23] X. Chen, Y. Xu, and A. Liu, "Cross layer design for optimizing transmission reliability, energy efficiency, and lifetime in body sensor networks," *Sensors*, vol. 17, no. 4, p. 900, 2017.
- [24] L. Wang, C. Huang, and X. Wu, "Cross-layer optimization for wireless body area networks based on prediction method," *J. Electron. Inf. Technol.*, vol. 40, no. 1, pp. 2006–2012, 2018.
- [25] M. M. Monowar, M. Mehedi Hassan, F. Bajaber, M. A. Hamid, and A. Alamri, "Thermal-aware multiconstrained intrabody QoS routing for wireless body area networks," *Int. J. Distrib. Sensor Netw.*, vol. 10, no. 3, Mar. 2014, Art. no. 676312.
- [26] Z. A. Khan, S. C. Sivakumar, W. J. Phillips, and B. Robertson, "QPRR: QoS-aware peering routing protocol for reliability sensitive data in body area network communication," *Comput. J.*, vol. 58, no. 8, pp. 1701–1716, Aug. 2015.
- [27] K. G. Mkongwa, Q. Liu, and C. Zhang, "Link reliability and performance optimization in wireless body area networks," *IEEE Access*, vol. 7, pp. 155392–155404, 2019.
- [28] V. Ayatollahitafti, M. A. Ngadi, J. B. M. Sharif, and M. Abdullahi, "An efficient next hop selection algorithm for multi-hop body area networks," *PLoS ONE*, vol. 11, no. 1, Jan. 2016, Art. no. e0146464.
- [29] J. K. Jayabarathan, A. Sivanantharaja, and S. Robinson, "Quality of service enhancement of mobile adhoc networks using priority aware mechanism in AODV protocol," *Wireless Pers. Commun.*, vol. 96, no. 4, pp. 5897–5909, Oct. 2017.
- [30] F. T. Zuhra, K. B. A. Bakar, A. A. Arain, K. M. Almufatah, T. Saba, K. Haseeb, and N. Islam, "LLTP-QoS: Low latency traffic prioritization and QoS-aware routing in wireless body sensor networks," *IEEE Access*, vol. 7, pp. 152777–152787, 2019.
- [31] J. I. Bangash, A. H. Abdullah, M. H. Anisi, and A. W. Khan, "A survey of routing protocols in wireless body sensor networks," *Sensors*, vol. 14, no. 1, pp. 1322–1357, Jan. 2014.
- [32] Z. Haider and K. Memon, "Adaptive routing protocol for wireless body area networks with heterogeneous nodes," *J. Netw. Commun. Emerg. Technol.*, vol. 8, no. 1, pp. 6–12, Jan. 2018.
- [33] A. Samanta, S. Bera, and S. Misra, "Link-quality-aware resource allocation with load balance in wireless body area networks," *IEEE Syst. J.*, vol. 12, no. 1, pp. 74–81, Mar. 2018.



and *ad-hoc* networks, routing algorithms, and network security.

SAIFULLAH MEMON received the master's degree from Quaid-e-Awam University of Engineering Science and Technology (QUEST), Nawabshah, Pakistan, in 2015. He is currently pursuing the Ph.D. degree in computer science with Beijing University of Posts and Telecommunication (BUPT), China. He is an Assistant Professor at QUEST. His research interests include wireless communication, wireless sensors, wireless body area networks, QoS issues in sensor



AMJAD REHMAN (Senior Member, IEEE) received the Ph.D. degree from the Faculty of Computing, Universiti Teknologi Malaysia, in 2010, with a specialization in forensic documents analysis and security. He is currently a Senior Researcher with the AIDA Laboratory, Prince Sultan University, Riyadh, Saudi Arabia. He is the author of more than 100 indexed articles. His research interests include data mining, health informatics, and pattern recognition.



IEEE TRANSACTIONS ON MULTIMEDIA, and IEEE TRANSACTIONS ON VEHICULAR TECHNOLOGY. His research interests include IoV and AIoT, SDN, overlay networks, and traffic engineering.

JINGYU WANG (Senior Member, IEEE) received the Ph.D. degree from Beijing University of Posts and Telecommunications, in 2008. He is currently a Professor with the State Key Laboratory of Networking and Switching Technology, Beijing University of Posts and Telecommunications. He has published more than 100 articles in international journals, including *IEEE Communications Magazine*, IEEE TRANSACTIONS ON CLOUD COMPUTING, IEEE TRANSACTIONS ON WIRELESS COMMUNICATIONS,



TONG XU received the Ph.D. degree from Beijing University of Posts and Telecommunications, in 2005. He is currently an Assistant Professor with the State Key Laboratory of Networking and Switching Technology, Beijing University of Posts and Telecommunications. He has published more than 30 articles in international journals. His research interests include service computing, pervasive service, and the Internet of Things.

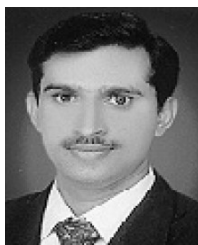

ALI RAZA BHANGWAR received the master's and Ph.D. degrees from Quaid-e-Awam University of Engineering, Science and Technology, Nawabshah, Sindh, Pakistan, in 2012 and 2019, respectively. Since then, he has been working as a Lecturer with the Computer Systems Engineering Department, Quaid-e-Awam University of Engineering, Science and Technology. His research interests include wireless communication and network security.



computing, cloud computing security, and information security. He has authored over 20 ISI and Scopus journal/conference papers, books, and book chapters. He is the Lead Editor for an edited book shortly to be published by Wiley titled *A Comprehensive Guide to IPTV Delivery Networks*. Besides, he is a member of different professional bodies as IACSIT, IAENG, and Institute of Research Engineers and Doctors, USA.

SULIMAN MOHAMED FATI (Senior Member, IEEE) received the B.Sc. degree from Ain Shams University, Egypt, in 2002, the M.Sc. degree from Cairo University, Egypt, in 2009, and the Ph.D. degree from Universiti Sains Malaysia (USM), Malaysia, in 2014. He is currently a Senior Researcher with the AIDA Laboratory, Prince Sultan University, Riyadh, Saudi Arabia. His research interests include the Internet of Things, machine learning, social media mining, cloud



LEI ZHANG received the Ph.D. degree from Beijing University of Posts and Telecommunications, in 2004. He is currently an Assistant Professor with the State Key Laboratory of Networking and Switching Technology, Beijing University of Posts and Telecommunications. He has published more than 20 articles in international journals. His research interests include NGN, 5G, pervasive service, and the Internet of Things.

...