

Received July 23, 2021, accepted August 18, 2021, date of publication August 25, 2021, date of current version September 2, 2021.

Digital Object Identifier 10.1109/ACCESS.2021.3107861

State-of-the-Art Review on Soft-Switching Technologies for Non-Isolated DC-DC Converters

XU-FENG CHENG¹, CHENYANG LIU², DIANLONG WANG³,
AND YONG ZHANG⁴, (Member, IEEE)

¹School of Mechanical Engineering, Hebei University of Science and Technology, Shijiazhuang 050018, China

²Marine Electrical College, Dalian Maritime University, Dalian 116026, China

³Hebei Key Laboratory of Material Near-Net Forming Technology, School of Materials Science and Engineering, Hebei University of Science and Technology, Shijiazhuang 050018, China

⁴School of Mechanical Engineering, Shanghai Jiao Tong University, Shanghai 200240, China

Corresponding author: Yong Zhang (yongzhang1977@sjtu.edu.cn)

This work was supported in part by the National Key Research and Development Program of China under Grant 2018YFB1502505, in part by the Key Research and Development Program of Hebei Province under Grant 20312205D, and in part by the Science and Technology Research Project of Hebei Colleges and Universities under Grant QN2020171.

ABSTRACT The soft-switching technology is widely used in DC-DC converters, DC-AC inverters, and AC-DC rectifiers. Soft-switching non-isolated DC/DC converters (Buck, Boost, and Buck-Boost) are the most active research area of the soft-switching technology, and fruitful results are achieved. However, there is currently no comprehensive review for the soft-switching technology of non-isolated DC/DC converters. This paper introduces soft-switching topologies for non-isolated DC/DC converters, and presents classification and characteristic of all kinds of soft-switching technologies. Some soft-switching technologies of derivative converters (non-inverting Buck-Boost converters and multiphase converters) are also presented. Finally future trends and generalized constitution methods of the soft-switching topology for non-isolated DC/DC converters are concluded. The soft-switching theory and constitution methods summarized in this article are expected to be able to guide the proposing of new soft-switching technologies for DC-DC converters.

INDEX TERMS Review, state-of-the-art, non-isolated DC-DC converter, ZVS, ZVT, soft-switching.

I. INTRODUCTION

Benefit from the simple structure, non-isolated DC-DC converters are widely used in renewable energy applications, which need not an electrical isolation, such as the hybrid energy storage system (HESS), electric vehicles (EV) and the photovoltaic power generation. Non-isolated DC-DC converters mainly include 6 types: Buck converter, Boost converter, Buck-Boost converter, Cuk converter, Sepic converter, and Zeta converter [1], [2]. All these DC-DC converters will become current reversible bidirectional DC-DC converters by replacing the power diode with a power transistor. Unidirectional non-isolated converters can only transfer the power from the DC power supply to the load with the output voltage step-up or step-down functions. And

The associate editor coordinating the review of this manuscript and approving it for publication was Sze Sing Lee¹.

bidirectional DC-DC converters have bidirectional power flow transmission capability also with step-up or step-down functions of the voltage at both sides.

In renewable energy applications, the switching frequency is required to be high to reduce the volume and mass of the non-isolated DC-DC converter prototype, meanwhile the voltage and current will be very large in these applications. These factors will cause severe switching losses in switching devices (power transistors and power diodes). The switching loss generally is the main loss in high-voltage, high-current, and high-frequency non-isolated DC-DC converters. In order to obtain an efficient and practical non-isolated DC-DC converter, the switching loss must be eliminated or reduced. We take the MOSFET as an example transistor to explain the mechanism of the switching loss. During the turn-on process of a MOSFET, the drain-source voltage V_S is decreasing, and the drain-source current (In this paper, it indicate the

total current of the switching unit) i_S is increasing. During the turn-off process of a MOSFET, the drain-source voltage V_S is increasing, and the drain-source current is decreasing. The overlapping portions of voltage and current will appear and produce the switching loss, which will be converted to heat. Therefore, the switching loss will not only affect the efficiency, but also increase the heat dissipation burden. A simple estimated method of the switching loss will be [3]:

$$P_{SL} = \frac{1}{2} V_B I_L f (t_{ON} + t_{OFF}) \quad (1)$$

where: V_B is the bus voltage; I_L is the load current; f is the switching frequency; t_{ON} is the turn-on time; t_{OFF} is the turn-off time.

Based on (1), we can know that the switching loss is proportional to V_B , I_L , f , and the switching time (the turn-on time and the turn-off time). The use of fast switching devices (such as SiC devices) can reduce the switching loss by reducing the switching time. However, this method cannot eliminate the switching loss. With the increase of the power and the switching frequency, the switching loss will still become very serious. Reducing or even eliminating the overlapping area of V_S and i_S during the switching process is another method to reduce the switching loss, which is called the soft-switching technology. There are four soft-switching forms: zero voltage switching on (ZVS-on), ZVS-off, zero current switching on (ZCS-on), and ZCS-off. For a practice MOSFET, snubber capacitors are usually used to connect with drain-source poles. Then these snubber capacitors can transfer most of the turn-off loss to the turn-on process [3]. Therefore, this turn-off loss can be reduced by a turn-on soft-switching method. Soft-switching conditions of turn-on process become more important. Thanks to the similar structure, most of soft-switching methods and important conclusions proposed for Buck, Boost, and Buck-Boost converters can also be used in Cuk, Sepic, Zeta converters and other derivative non-isolated DC-DC converters.

In recent decades, soft-switching technologies have achieved rapid development. Many modern DC-DC converters have adopted soft-switching technologies to improve efficiency and reduce heat generation. However there is no literature on the state-of-the-art review of soft switching technologies for non-isolated DC-DC converters. Therefore this paper summarizes and classifies main soft-switching technologies for non-isolated DC-DC converters, and gives the introduction of the latest soft-switching technologies. Then several soft-switching topology derived methods are summarized and presented. The contribution of this paper is:

(1) A comprehensive state-of-the-art review of soft-switching topologies for non-isolated DC-DC converters is presented.

(2) Based on the state-of-the-art review, several generalized soft-switching topology derived methods are summarized and presented for non-isolated DC/DC converters.

(3) Based on the soft-switching theory and constitution methods summarized in this article, considering the industrial

practice, future development trends and areas of soft-switching technologies is discussed.

(4) The comprehensive summary of soft-switching technologies and converters in this paper will provide theory basics for the exploration and discovery of new soft-switching technologies in the future, and promote further applications of soft-switching technologies in various industry areas.

This paper concerns soft-switching technologies used for Buck, Boost, Buck-Boost and their derived converters. And most of these soft-switching technologies can also be applied in Cuk, Sepic, and Zeta converters. The structure of this paper is organized as: Section II gives the basic soft-switching principle and the classification of soft-switching topologies for non-isolated DC-DC converters. Base on this classification, section III give an introduction of control-only soft-switching topologies. Section IV presents the non-auxiliary-switch soft-switching technologies, and section V introduces auxiliary-switch soft-switching technologies. Finally section VI and VII discuss features, topology constitution methods, and future trends of soft-switching technologies for non-isolated DC/DC converters, and summarizes all the work of this paper.

II. BASIC PRINCIPLES OF SOFT-SWITCHING TECHNOLOGIES

A. SOFT-SWITCHING WAVEFORMS AND SAVED LOSSES

At the first, we defines the switching unit in this section as a MOSFET (or other transistors) with necessary auxiliary structures such as the body diode (or the anti-parallel diode), the snubber inductor, or the snubber capacitor. In this section, we will present the soft-switching principle of non-isolated DC-DC converters at the view of switching waveforms (V_G , V_S , i_S) and switch structures. The target of soft-switching technology is to reduce or even eliminate the overlapping area of V_S and i_S during the switching period. Therefore four soft-switching forms can be obtained as ZVS-on, ZCS-on, ZVS-off, and ZCS-off, which are shown in FIGURE 1. It should be noted that waveforms in FIGURE 1 is used to indicate the interrelation of V_G , V_S , i_S , therefore the shape of V_G will not be a standard rectangle, and the shape of V_S can be rectangular, sinusoidal or others. Then we will presents detail waveform characteristics and corresponding descriptions of each soft-switching form in the following.

1) ZVS-OFF CONDITION

The usual method of the ZVS-off condition is to connect a snubber capacitor to the MOSFET (S) in parallel. According to [3], the switching loss saved by this ZVS-off condition will be transfer to the turn-on process, so a ZVS-on condition is required with this condition.

2) ZCS-ON CONDITION

The switching unit in this condition is composed of a MOSFET (S with the body diode) and a small snubber inductor (L). This snubber inductor is connected with the

MOSFET in series, and is used to limit the rise rate of the turn-on current. Due to the existence of L , the increase rate of i_S is reduced, and the ZCS-on conditions is obtained. All the typical ZCS method uses a snubber inductor, which will be the main inductor, an auxiliary inductor, or a mutual inductor generated by other inductors in the actual converter, to cascade with the MOSFET or other transistors. One notable aspect is that the energy of the snubber inductor should be released before the next turn-on process.

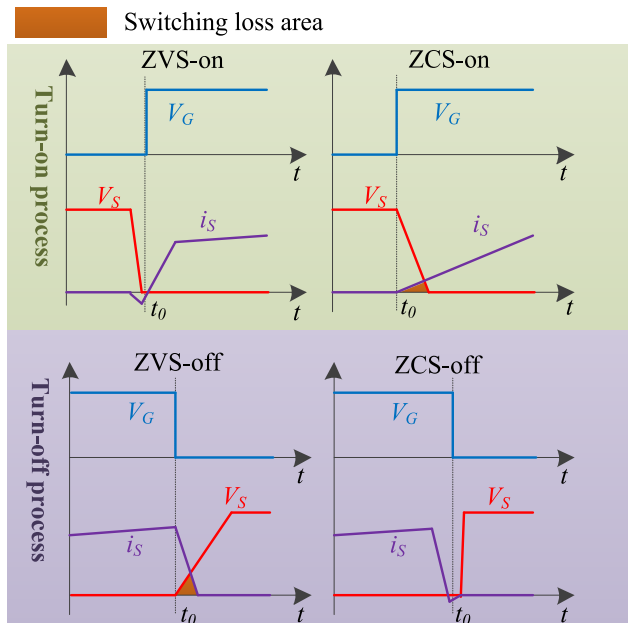

FIGURE 1. Several main soft-switching waveforms.

3) ZVS-ON CONDITION

This condition requires that the switching unit is composed of a MOSFET (including the body diode) and a snubber capacitor. A reverse current is generated to discharge the capacitor before the MOSFET is turned on. Then the voltage of the snubber capacitor is discharged to 0. And the body diode will conduct, the drain-source voltage (V_S) is clamped to be 0. The MOSFET will turn on under ZVS-on condition. The realization key of the ZVS-on condition is the reverse current generated before the switching unit is turned on.

4) ZCS-OFF CONDITION

The structure of the switching unit in this condition is same to the ZCS-on condition without the snubber inductor. Before starting of the turn-off process, the switching unit is conductive, and the drain-source current i_S reduced when closing to the switching time point. Before the MOSFET is turned off, i_S decreases to be a small negative value, then the switching unit can turn off under ZCS-off condition.

Abovementioned soft-switching forms also need other auxiliary circuits or control strategies in addition to the switching unit structure. For the ZVS-off condition, a soft-switching turn-on condition is required; otherwise the

turn-off saved loss will occur in the turn-on process. For the ZCS-on condition, appropriate auxiliary circuit or control strategies are required to achieve 0-reset by releasing the energy of the snubber inductor before the next turn-on process. For ZVS-on condition and ZCS-off condition, auxiliary circuit or control strategies are required to generate the reverse current across the switching unit.

B. SAVED LOSSES BY SOFT-SWITCHING TECHNOLOGY

The soft-switching technology can save switching loss. This section will give saved loss by different soft-switching conditions. Based on (1), the saved loss of the ZVS-off condition will be:

$$P_{SL} = \frac{1}{2} I_L f (V_{BH} t_{OFFH} - V_{BS} t_{OFFS}) \quad (2)$$

V_{BH} is the bus voltage under hard-switching condition, and V_{BS} is the equivalent bus voltage under ZVS-off condition; t_{OFFH} is the turn-off time under hard-switching condition, and t_{OFFS} is the turn-off time under ZVS-off condition. From this equation, we can know that V_{BS} will be smaller than V_{BH} when the increase rate of V_S is reduced. t_{OFFS} will be also different from t_{OFFH} . But the turn-off loss will be reduced in summary.

Similarly the saved loss of the ZCS-on condition will be:

$$P_{SL} = \frac{1}{2} V_B f (I_{LH} t_{ONH} - I_{LS} t_{ONS}) \quad (3)$$

I_{LH} is the load current under hard-switching condition, and I_{LS} is the equivalent load current under ZCS-on condition; t_{ONH} is the turn-on time under hard-switching condition, and t_{ONS} is the turn-on time under ZCS-on condition. From this equation, we can know that I_{LS} will be smaller than I_{LH} when the increase rate of i_S is reduced. t_{ONS} will be different from t_{ONH} . But the turn-on loss will be reduced in summary.

In summary, ZVS-on and ZCS-off conditions can almost completely eliminate the switching loss, but ZVS-off and ZCS-on conditions can only reduce the switching loss. Saved losses for ZVS-on and ZCS-off conditions will be all the switching loss, therefore ZVS-on and ZCS-off conditions are most meaningful methods. The saved loss of the ZVS-on and ZCS-off condition will respectively be:

$$P_{SL} = \frac{1}{2} V_B I_L f t_{ON} \quad (4)$$

$$P_{SL} = \frac{1}{2} V_B I_L f t_{OFF} \quad (5)$$

C. SOFT-SWITCHING TECHNOLOGY CLASSIFICATIONS

At present, the research of soft-switching non-isolated DC-DC converters has been very rich. The classification of soft-switching non-isolated DC-DC converter is very complicated and overlapping each other. To simplify this process, based on the auxiliary circuit structure (with or without auxiliary circuits; with or without active devices), these soft-switching technologies can be classified into 3 main categories as: control-only technologies (COT), non-auxiliary-switch technologies (NAST), auxiliary-switch

technologies (AST), which are shown in FIGURE 2. Detailed descriptions of these soft-switching technologies are:

1) COT

The control-only technology (COT) provides soft-switching conditions for the non-isolated DC-DC converter without using any auxiliary circuit. By appropriate parameter design and switching timing control modulation method, all non-isolated DC-DC converters can operate under ZCS-on or ZVS-on conditions. The key of this technology is the control strategy, therefore this method is the simplest method in topological structure. The control-only technology needs complex control strategies, and has a large peak-to-peak current across the main inductor. Thus the efficiency is not very high with fixed frequency control method.

TABLE 1. Soft-switching form and losses.

Main Classification	Sub Classification	Technology	Soft-switching Form	Saved Loss
COT	COT	DCM/CRM	ZCS-on	(3)
		TCM	ZVS-on	(4)
NAST	QRC	ZCS-QRC	ZCS-on	(3)
		ZVS-QRC	ZVS-on	(4)
		Other	ZCS/ZVS-on	(3), (4)
	ALCC	-	ZVS-on	(4)
	PSC	-	ZCS-on/ZVS-off	(2), (3)
AST	Active RC/ Active SC	-	ZCS-on/ZVS-off	(2), (3)
	ZVTC	-	ZVS-on	(4)
	ZCTC	-	ZCS-off	(5)

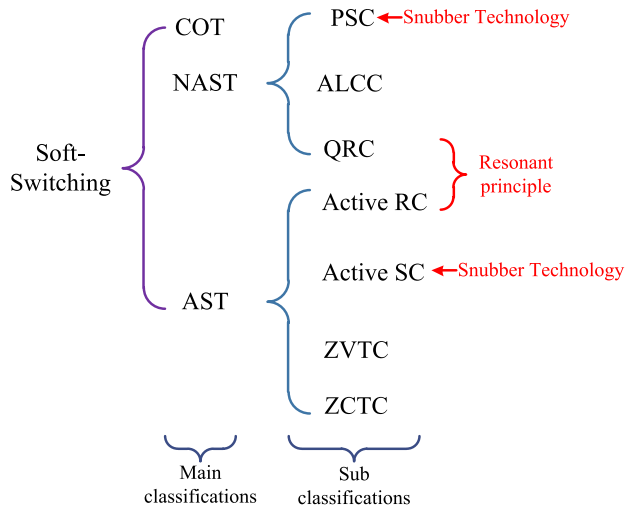

FIGURE 2. Soft-switching technology classifications.

2) NAST

In order to further improve the efficiency of non-isolated DC-DC converters, the auxiliary circuit should be added in the converter. If the auxiliary circuit does not contain a switch that can be actively controlled such as MOSFET and IGBT, this is the non-auxiliary-switch technology (NAST). Therefore the NAST uses auxiliary circuit without active devices. Based on the implementation principle, the NAST includes quasi-resonant converters (QRC), passive snubber converters (PSC), and auxiliary commutation converters (ALCC). QRC usually uses small inductors and capacitors connected with the switching unit in series or parallel. Then ZCS or ZVS conditions can be obtained. PSC uses a snubber net composed of inductors, diodes, and capacitors to achieve ZVS or ZCS conditions. ALCC uses auxiliary circuits to generate an additional auxiliary current between two semiconductor devices to composite current waveforms needed by ZCS or ZVS conditions.

3) AST

If the auxiliary circuit contains switches that can be actively controlled, the auxiliary-switch technology (AST) can be

obtained. This technology includes zero voltage transition converters (ZVTCs), zero current transition converters (ZCTCs), active resonant converters (active RC) and active snubber converters (active SC). The ZVTC achieves ZVS-on conditions (FIGURE 1) with the help of the auxiliary switches. The ZCTC achieve ZCS-off conditions (FIGURE 1) with the help of the auxiliary switches. The active RC adds active switches to the resonant converters to obtain a fixed frequency control characteristics. And the active SC is the PSC with an active switches added in the auxiliary circuit.

In our papers, the main classification is clear and unambiguous, because it is based on the structure of with/without auxiliary circuits or with/without active devices. However the sub classification has overlapping phenomena. Different soft-switching technologies may use the same theory as shown in FIGURE 2. For example, the PSC and the active SC both use the snubber technology, and the QRC and the active RC both use the resonant principle. Soft-switching form and losses for each soft-switching technology is shown in TABLE 1. In following sections, we will give detailed introductions of abovementioned several soft-switching technologies.

III. CONTROL-ONLY TECHNOLOGIES

As mentioned above, the control-only soft-switching DC-DC converter has no auxiliary circuits but the control modulation strategy for the switching unit. There are three basic soft-switching modulation strategies: discontinuous conduction mode (DCM), critical conduction mode (CRM), and triangular current mode (TCM) [4]–[6]. The waveform of current across the main inductor is triangular, and the whole waveform will be above the zero-current axis in continuous conduction mode (CCM). If the inductance of the main inductor is reduced, or the load resistance increased, this current waveform will move down. When the minimum value of the waveform is equal to 0, we obtain the CRM waveform. By changing the switching frequency based on the load condition, the CRM DC-DC converter can obtain ZCS-on condition at wide load range. Continue to move

down this current waveform, the DCM waveform will be obtained if the DC-DC converter is unidirectional, and the TCM waveform will be obtained if the DC-DC converter is bidirectional. The DCM DC-DC converter can also obtain ZCS-on condition, and the TCM DC-DC converter can achieve ZVS-on condition.

The TCM DC-DC converter can eliminate almost all turn-on losses and most turn-off losses. Constant frequency control TCM non-isolated DC-DC converters have low light-load efficiency. In order to improve the light load efficiency of the Boost converter, Alberto Rodriguez *et al.* [5] proposes a quasi-square wave mode with ZVS (QSW-ZVS), which is the TCM with fixed minimum value of current waveform and variable frequency. This method can also be used on other non-isolated DC-DC converters. Besides, the TCM can also be used in the non-inverting Buck-Boost converter, which is shown in FIGURE 3. The non-inverting Buck-Boost converter can be regarded as a cascaded DC-DC converter of a Buck converter and a Boost converter without the low-side filter capacitor. Based on the switching characteristics of the non-inverting Buck-Boost converter, 6 modulation strategies are proposed [7]. And the waveform of a soft-switching modulation strategy is shown in FIGURE 3. Based on these modulation strategies, some practical soft-switching control modulation strategies for the non-inverting Buck-Boost converter are proposed by [8]–[10]. These control modulation strategies obtained a high efficiency up to 98% at the power of 4 kW.

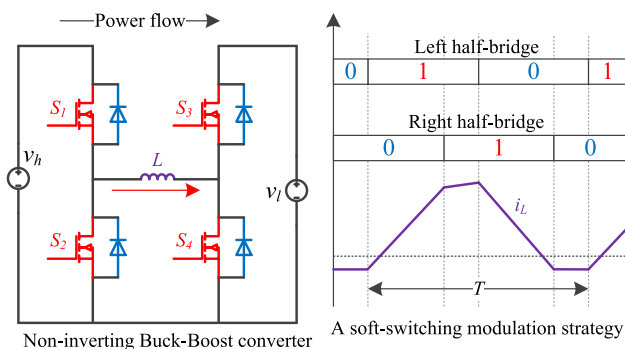

FIGURE 3. The non-inverting Buck-Boost converter.

IV. NON-AUXILIARY-SWITCH TECHNOLOGIES

The non-auxiliary-switch soft-switching technology includes the QRC, the PSC, and the ALCC. This section will present soft-switching non-isolated DC-DC converters using these technologies. We mainly concerned with the latest technological developments, therefore new converters proposed in recent years will be given descriptions in detail.

A. QUASI-RESONANT CONVERTERS

The QRC firstly proposed by F.C.Y. Lee and his partners use the resonant switching unit, which is composed of transistors, inductors, and capacitors, to replace the general switch of

non-isolated DC-DC converters [1], [11]–[13]. QRCs have two types: ZCS-QRCs and ZVS-QRCs, whose switching units are shown in FIGURE 4 [11]–[13]. In FIGURE 4, L_r is the resonant inductor, and C_r is the resonate capacitor. T is the unidirectional switch, and can be configured to half-wave mode and full-wave mode. In ZCS-QRCs, the resonant inductor is cascaded with the unidirectional switch to reduce the current rising rate, and then the ZCS condition is obtained. The resonant capacitor is used to release the energy stored in the resonant inductor before the next turn-on process. Then the ZCS conditions will occur in every period. In ZVS-QRC, The resonant capacitor is connected in parallel to the unidirectional switch. The resonant tank between the resonant capacitor and the resonant inductor is used to generate ZVS conditions. By applying these switching units of FIGURE 4 to non-isolated DC-DC converters, a large number of soft-switching QRC topologies can be obtained. The resonant frequency of the QRC is usually higher than the switching frequency. In order to obtain detailed characteristics, Be-Tao Lin *et al.* [14] proposed a unified modeling, synthesizing, and analyzing method for QRCs.

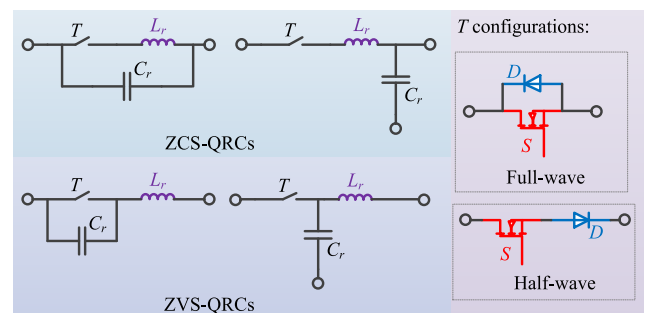

FIGURE 4. Switching units of QRCs.

Traditional QRCs has disadvantages such as variable switching frequency and increased current or voltage stress. Based on the similar principle, a lot of new improved QRCs are proposed as multi-resonant converters (MRCs) [15]–[17], constant frequency bidirectional resonant converters (CF-BRCs) [16]–[18], new resonant DC-DC converters with LC circuit [19], [20], and new single switch quasi-resonant converters (SS-QRCs) [21]–[24]. MRCs usually employ a multi-element resonant network, and the ZVS-MCR is suitable for high switching frequency converters. CF-BRCs solved the variable frequency control problems of traditional QRCs.

The SS-QRC is an ancient but very useful soft switching method, until now, new topologies based on the SS-QRC theory are still being proposed. In recent years, the SS-QRC is proposed to obtain characteristic of reduce inductor size, inherent power factor correction (PFC) features, and etc. The SS-QRC employs small inductors and capacitors to reduce the weight and volume. And full soft-switching capability with ZVS/ZCS conditions is obtained. So the efficiency and power density is improved.

B. PASSIVE SNUBBER CONVERTERS

Passive snubber converters use a passive snubber net (PSN), which consist of diodes, inductors and capacitors, to obtain ZCS-on and ZVS-off conditions. The reverse recovery loss of diodes in the snubber net will also be reduced by reasonable design. As shown in FIGURE 5, the transistor will usually be cascaded to a small inductor (or a virtual inductor), which will be implemented by an actual inductor, the mutual inductance or other method. Besides, the position of transistor and inductor can be interchanged. The inductor is used to reduce the current ascent rate, and the capacitor is used to reduce the voltage ascent rate, then ZCS-on and ZVS-off conditions can be obtained. Meanwhile the PSN must have voltage and current reset function for inductors and capacitors in one period to prepare for the soft-switching of the next period. Based on the using of coupled inductor, there are two type of PSN: PSN type I that has no coupled inductor; PSN type II that uses coupled inductors.

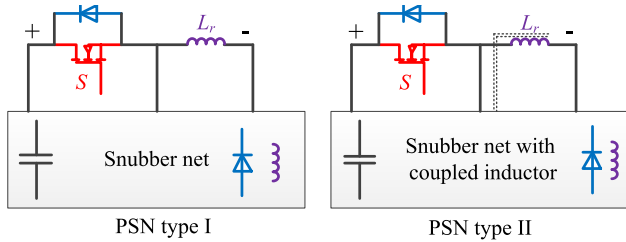

FIGURE 5. Passive snubber structure.

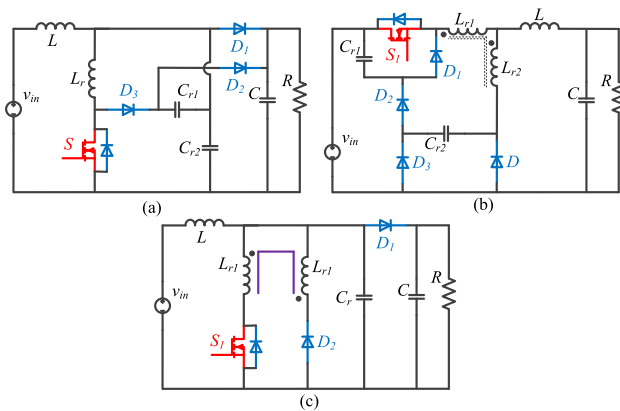

FIGURE 6. Typical passive snubber converters. (a) A PSN boost converter [31]. (b) A PSN buck converter with coupled inductors [38]. (c) A simplified structure PSN boost converters with coupled inductors [42].

The typical PSN DC-DC converter has a complex structure, which employed several inductor, capacitor, and diodes [25]–[33]. A PSN boost converter is shown in FIGURE 6 (a) [31]. The L_r will reduce the current rising rate when S is turned on; C_{r1} and C_{r2} will reduce the voltage rising rate when S is turned off; D_2 and D_3 perform auxiliary circuit reset function. In order to improve the performance or simplify the structure of typical PSN DC-DC converters, the coupled inductor is introduced. The coupled inductor PSN

converters use the snubber inductor coupled with the main inductor [34]–[37], or other inductors [38]–[41], one example is shown in FIGURE 6 (b).

The PSC is very commonly used soft-switching method, but almost all books will not list it as the soft-switching technology. In this paper, we give the detailed introduction. In recent years the new PSC also keep appearing, Mohammad Reza Amini et al. [42] gave a very simple PSN using a coupled inductor as shown in FIGURE 6 (c), this PSN has a very simple structure with employing a coupled inductor and a diode. The ZCS condition will be obtained, and the efficiency and power density is improved. Bo H. Choi et al. [43], [44] used a tapped inductor instead of the coupled inductor to reduce the weight and volume. These new PSN DC-DC converters further optimize the performance of the PSN.

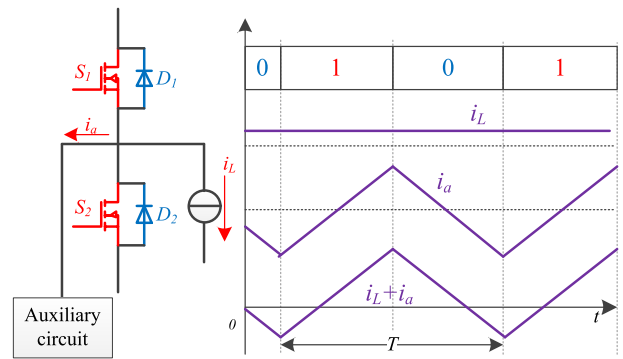

FIGURE 7. Auxiliary commutation structure and waveforms.

C. AUXILIARY COMMUTATION CONVERTERS

Auxiliary commutation converters (ALCs) employ auxiliary circuits to change waveforms across power transistors. As shown in FIGURE 7, assume that the main inductor is large enough to be considered as a current source at CCM. If an auxiliary current (i_a) generated by the auxiliary circuit has following characteristics: i_a will make the composited current ($i_a + i_L$) to be negative when S_1 is turning on, and be positive when S_2 is turning on, the current across S_1 and S_2 will clamp drain-source voltages of S_1 and S_2 to be 0. The ZVS turn-on condition will be obtained. Based on the classification of auxiliary circuits, ALC has two types: capacitor inductor ALC (CL-ALC), and coupled inductor and diode ALC (CLD-ALC). CL-ALCs employ the auxiliary circuit composed of capacitors and inductors shown in FIGURE 8 (a) and (b) [45]–[47], and have the same ZVS turn-on waveforms to FIGURE 7. Besides, CL-ALCs can also be configured to be unidirectional operation [48], [49], bidirectional operation [45], [46], [50] or ZCS operation [51]. The CL-ALC in [50] can also obtain the filter characteristic. And CL-ALCs in [47], [52] use the magnetic coupling effect to improve the converter performance.

CL-ALCs always have a larger ripple even if they are configured to be unidirectional operation, where the

positive ripple of i_a is not necessary. Then the CLD-ALC is proposed to eliminate the positive section of i_a at unidirectional applications. CLD-ALCs are relatively new soft-switching method proposed from the year of 2003, and can provide ZCS conditions (ZCS CLD-ALCs in [56], [57], can also be considered as PSN DC-DC converters) and ZVS conditions [53]–[65], two examples of which are shown in FIGURE 8 (c) and (d) [53]–[56]. Both ZCS CLD-ALCs and ZVS CLD-ALCs employ a coupled inductor and a power diode as the auxiliary circuit. CLD-ALCs can also be extended to the non-inverting buck-boost converter (NIBBC) [59], [60] or replace the auxiliary power diode to be a transistor [61], [62]. Some bidirectional buck/boost converters based on CLD-ALC are also proposed by [63]–[65].

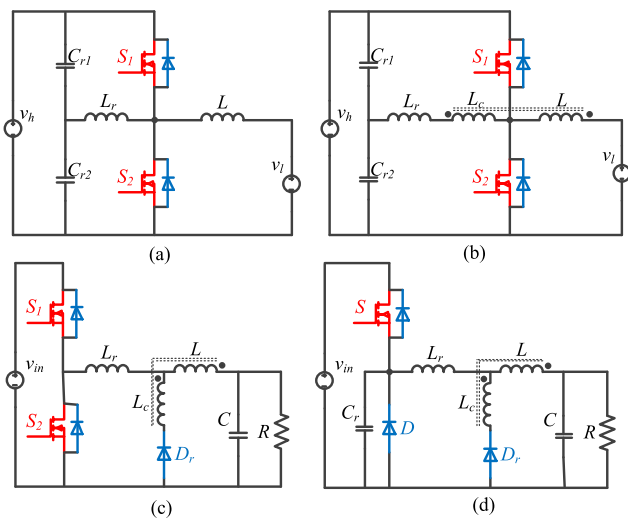

FIGURE 8. Auxiliary commutation converters. (a) and (b) CL-ALCs [45]–[47]. (c) and (d) CLD-ALCs [53]–[56].

The CL-ALC is a method that was proposed very early, but the CLD-ALC is firstly proposed by Y. Zhang, and P. C. Sen in 2003 [53]. In recent years, Lei Jiang, H. Do, Y. Berkovich, G. Chen, Xu-Feng Cheng, *et al.* did a lot of research on the CLD-ALC, and proposed numerous number of new CLD-ZLC topologies. This research promotes the development and application of the CLD-ALC and enriches related theories. In the future more new topologies will continue to be proposed.

V. AUXILIARY-SWITCH TECHNOLOGIES

The NAST cannot freely control the generation and elimination of the auxiliary current, which will introduce extra auxiliary losses. Besides, some soft-switching converters need auxiliary switches to obtain the constant-frequency control characteristic. Therefore this section will give the detailed review of ASTs. ASTs include ZVTCs, ZCTCs, active resonant converters (RCs) and active snubber converters (SCs).

A. ZVT CONVERTERS

The ZVTC uses auxiliary power transistors to create ZVS conditions for main power transistors. Auxiliary power transistors will be turned on before main power transistors, then the auxiliary current across the snubber capacitor and the resonant inductor will clamp the voltage of main transistors to 0, which obtains ZVS conditions. By appropriate design, auxiliary power transistors will also obtain ZVS or ZCS conditions. By auxiliary power transistor, the generation of auxiliary currents is limited to a short time, and then the auxiliary loss is greatly reduced. However auxiliary power transistors need extra control and driving circuits, which will increase the cost and control complexity. Typical ZVTC auxiliary circuits usually consists of one resonant inductor, two power transistors (or one transistor plus one diode), which are shown in FIGURE 9. A resonant tank will occur between the resonant inductor and the snubber capacitor (or the parasitic capacitance C_{DS}) connected with main transistors. One transistor is used to control the generation of the resonant tank, the other is used to release the energy in the resonant inductor. Then the ZVTC will obtain a ZVS conditions at the turn-on process.

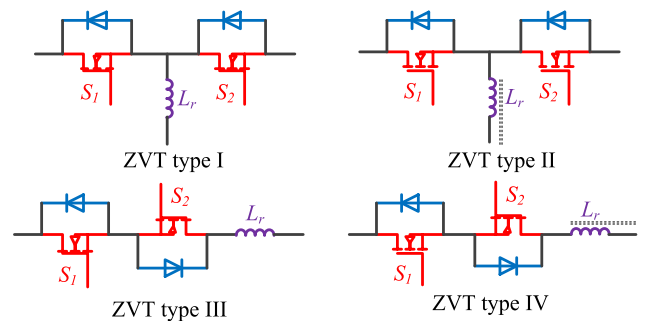

FIGURE 9. ZVTC auxiliary circuits.

The ZVTC is also a traditional soft-switching technology accompanied by a lot of existing topologies. The research direction of these years is to obtain bidirectional soft-switching operation and improve the performance using the magnetic coupling method and new auxiliary circuit structure. Apply ZVTC auxiliary circuits to the specific converter, lots of ZVT non-isolated DC-DC converters are proposed by [6], [66]–[80]. Four representative ZVTCs are shown in FIGURE 10 [66]–[71]. In 2016, M. R. Mohammadi proposed a family of new ZVT converters as shown in FIGURE 10 (d) [71]. These ZVT converters are brand new ZVT topologies, and have high efficiency and high power density. Guipeng Chen *et al.* present the topological deduction and unified analysis of new ZVT converters shown in FIGURE 10 (d) [77], [78]. All these ZVTC auxiliary circuits can be used in unidirectional and bidirectional DC-DC converters like Buck, Boost, Buck-Boost, Cuk, Zeta and Sepic. By adding extra diodes, inductors and capacitors,

some improved ZVTCs based on ZVTC auxiliary circuits are proposed by [81]–[87].

Also the ZVTC can be combined with the ZCS passive snubber circuits in FIGURE 6 to be new ZVTCs as shown in FIGURE 11 (a) [88]–[91]. These ZVTCs use the diode to release the energy of the ZCS inductor in the auxiliary circuit. Although these converters employ many auxiliary devices, the voltage and current stress is reduced. Meanwhile Das, P. *et al.* [92], [93] propose ZVT active clamped converters with only one auxiliary switch at bidirectional operation as shown in FIGURE 11 (b). These ZVTCs use one auxiliary switch to give soft-switching conditions for the bidirectional Buck/Boost converter with a very complicated control strategy.

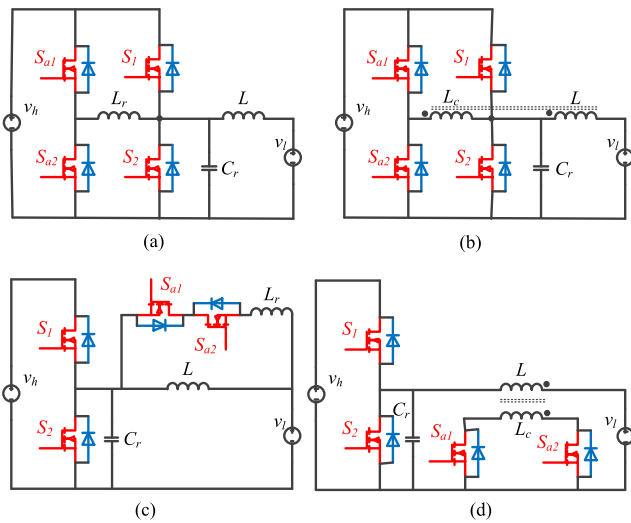

FIGURE 10. ZVTCs with different configurations. (a) Traditional bidirectional ZVTC [66], [67]. (b) Traditional bidirectional ZVTC with coupled inductors [68], [69] (c) ZVTCs with type III [70]. (d) ZVTCs with type IV [71].

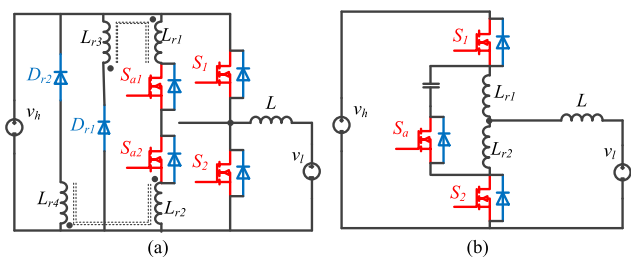

FIGURE 11. Other ZVT converters. (a) ZVTCs with passive snubber circuit. (b) single-switch ZVT BDC.

B. ZCT CONVERTERS

ZVTC auxiliary circuits are composed of power transistors with an inductor in series, but a ZCTC auxiliary circuit is composed of power transistors with a capacitor in series. ZCTCs will usually provide a ZCS turn-off condition [6], [94]–[106] (FIGURE 12) with a ZCS turn-on condition [6], [95]–[100] (FIGURE 12 (a)) or a ZVS turn-on condition [101] for main transistors. Combine ZVTC

and ZCTC technologies, some ZVT-ZCT-PWM DC-DC converter have been proposed in [102]–[105] (FIGURE 12(b)). These converters can obtain ZVS turn-on and ZCS turn-off conditions, and then the efficiency will be greatly improved. Besides, M. Amin *et al.* [106] proposed a bidirectional buck/boost converter with a ZCT buck mode and a ZVT boost mode.

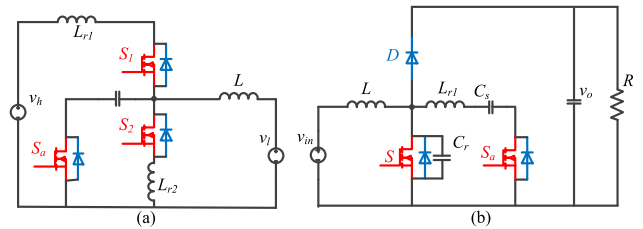

FIGURE 12. ZCTCs. (a) A ZVTC with ZCS turn-on and turn-off [97]. (b) A ZVT-ZCT-PWM DC-DC converter [102].

C. ACTIVE RC/SC

Traditional soft-switching QRCs have some disadvantage such as need pulse frequency modulation (PFM) and increased current and voltage stress. In order to solve these problems, several active resonant converters (RCs) are proposed [107]–[109], [111], [112], one of which [109] is shown in FIGURE 13 (a). These converters also use extra auxiliary transistors to control the resonant process. Similarly, the snubber converter (SC) can also be configured to be active SC by using active switches [113]–[120]. In active SCs, an extra transistor is introduced to the snubber net to control the soft-switching occurring process, and the auxiliary loss can be reduced. One typical active SC is shown in FIGURE 13(b). In most active SCs, auxiliary transistors have different control timing comparing to the main transistors. This point will increase the control complexity and consume more computing resources. To improve this problem, some active SCs have the synchronous turn-on and turn-off behavior between auxiliary and main transistors [117], [120].

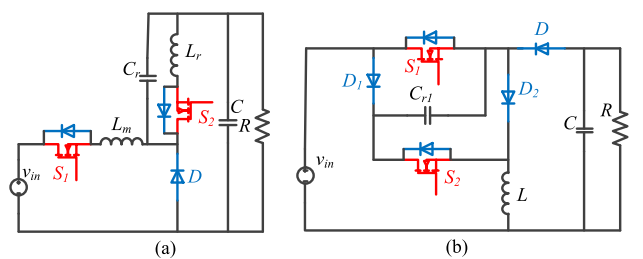

FIGURE 13. Active QRC/PSCs. (a) Buck-N [109]. (b) Active snubber buck-boost converter [120].

VI. COMPARISON AND PROSPECT

A. COMBINED CONVERTERS

In order to obtain various functions, or increase the rated power, single DC-DC converters (buck, boost, buck-boost

converters, and etc.) can be connected in series or in parallel respectively to be the cascaded DC-DC converter or the multiphase DC-DC converter. The multiphase converter is the parallel connected converters by two or more single DC-DC converters. By the interleaved control method, multiphase DC-DC converters can obtain reduced output current ripple and greater rated power. For interleaved multiphase DC-DC converters, abovementioned soft-switching technologies are also suitable, several soft-switching multiphase DC-DC converters are also proposed as control-only soft-switching interleaved converters [121], [122], ZVS/ZVT interleaved converters [123]–[135], and ZCS/ZCT interleaved converters [136]–[141]. Article [121] proposed a high-power density design of a soft-switching three-phase bidirectional DC-DC converter without any auxiliary circuit. This converter has the power of 100kW. Article [122] proposed a ZVS interleaved DC-DC converter by establishing coupling effects between main inductors with variable coupling coefficient. In 2017 a ZVT interleaved boost converter is proposed using an auxiliary coupled inductor as shown in FIGURE 14. (a) [128]. Its maximum efficiency exceeds 97%. In 2018, Yie-Tone Chen [129] proposed a interleaved boost converter with coupled-inductor, and this converter only use one auxiliary circuit to generate soft-switching conditions for all transistors. The interleaved multiphase DC-DC converter can increase output power and reduce current ripple. Therefore the soft-switching technology for multiphase DC-DC converter can be widely used in industrial electronics equipment, transportation and information equipment. Until now, new soft-switching interleaved DC-DC converters are emerging.

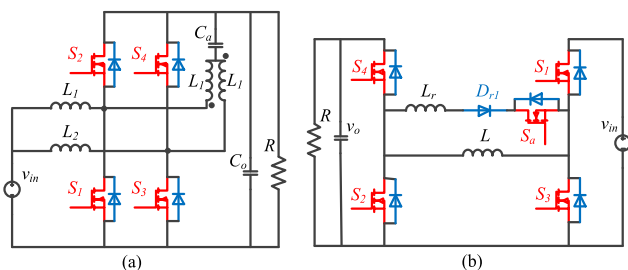

FIGURE 14. Two combined converters s. (a) ZVT interleaved boost converter with coupled inductor [128]. (b) ZVT NIBBC [143].

The main cascaded DC-DC converter is the non-inverting buck-boost converter (NIBBC), which also can be called cascaded buck+boost converter, and four/two switches buck-boost converter. It is reversely connected by a buck converter and a boost converter without the low side DC-link capacitor. For the NIBBC, above-mentioned soft-switching methods can be used to be control-only soft-switching NIBBCs [7], [9], ALC ZVS NIBBCs [59], [60], [142], and ZVT NIBBCs [143]–[145]. The NIBBC has several soft-switching modulation methods listed by [7]. Based on these methods, S. Waffler and J. W. Kolar proposed a low-loss modulation strategy for high-power NIBBC with a peak

efficiency of 98.3% [9]. J. Xue, X. F. Cheng, Y. Zhang *et al.* applied ALC technology to the NIBBC, and obtained a lot of new soft-switching NIBBCs [59], [60], [142]. In 2019 L. Cong *et al.* proposed a ZVT NIBBC with only one ZVT auxiliary circuit. This new converter has a peak buck-boost efficiency of 92.5% at the switching frequency of 1MHz [143]. The NIBBC has the superiority of arbitrary voltage conversion function, but its efficiency is low because of the using of four transistors. The soft-switching technology will improve the efficiency of the NIBBC to obtain more extensive applications. Currently, the soft-switching technology of the NIBBC is insufficient. With the addition of more researchers, more new soft-switching topologies of the NIBBC will be constantly created.

B. SOFT-SWITCHING OF SIC AND GAN

Wide-bandgap devices such as SiC and GaN have different characteristics comparing to traditional silicon-based devices. SiC devices have the higher withstand voltage and switching frequency with strict drive requirements. GaN devices can operate at a very high frequency up to several MHz. Therefore Existing soft-switching technologies should be fully assessed before applying to the wide-bandgap-device-based DC-DC converter.

P. Ranstad *et al.* [146] presents the experimental evaluation of SiC switches for the soft-switching converter comparing to the Si IGBT with the loss reduction up to 65%. A. Jafari *et al.* [147] compare the soft-switching loss between GaN and SiC devices at the high switching frequency. M. R. Ahmed *et al.* [148] proposed a circuit-level analytical model to predict the switching Behavior of SiC MOSFET under different conditions such as hard-switching, soft-switching, and false turn-on. Abovementioned studies promote the understanding of the switching characteristics of SiC devices and the development of soft-switching technologies of SiC converters. Articles [5], [149], [150] study the control and Modulation strategy for the SiC non-isolated DC-DC converters with significant efficiency improvements.

For GaN devices, R. Li *et al.* [151] gives the analysis and verification for the dynamic on-resistance at both hard-switching and soft-switching conditions. Articles study GaN-based soft-switching DC-DC converters to evaluate the characteristic of GaN devices and improve the efficiency and power density of DC-DC converters. Overall, GaN-based soft-switching DC-DC converters are suitable for low voltage UHF applications such as totem pole rectifiers, high-power mobile phone chargers. SiC-based converters are suitable for high-voltage and high-power applications to replace IGBT such as electric vehicle power conversion, chargers, and motor drive systems.

C. CONSTITUTIONS AND FEATURES

TABLE 2 presents features of different soft-switching technologies in this paper. We give power rating, peak efficiency, operating range, pros, cons and applications of the COT, the QRC, the PSC, the ALC, the ZVT/ZCT, and the

TABLE 2. Features of different soft-switching technologies.

Soft-switching	Power Rating	Peak Efficiency	Operating Range	Pros, Cons and Applications
COT	< Several kW	>98%	Several kHz – hundreds kHz	Large current ripples in the main inductor; Need suitable modulation and control strategy; Be suitable for high-voltage low-current applications. Be widely used in new energy fields such as the photovoltaic, the wind energy and electric vehicles.
QRC	< Several kW	>98%	Several kHz – Several MHz	Large current ripples across auxiliary circuits and switching devices; Need variable frequency control strategy; Be suitable for high-frequency low power DC-DC converters such as power supply modules for electronic circuits and portable electronic equipment.
PSC	< Several kW	>99%	Several kHz – Tens of MHz	Complicated auxiliary circuits; Cannot completely reduce switching losses. Used in switched-mode power supplies in industry and portable electronic equipment.
ALC	< Several kW	>97%	Several kHz – Several MHz	Obtain continuous inductor current with ZVS conditions; Fixed frequency control; Simple auxiliary circuit. Used in the HESS and the EV.
ZVT/ZCT	< Tens of kW	>97%	Several kHz – hundreds kHz	High efficiency with complex timing control; Be not suitable for high frequency converters. Used in telecom, the HESS, the power factor correction (PFC) and the EV.
Active RC/SC	< Several kW	>97%	Several kHz – Several kHz	Constant-frequency control; Complex auxiliary timing control. Also used in power supply modules for electronic circuits and portable electronic equipment.

active RC/SC. These characteristics indicate that the single performance of some DC-DC converters reached this range. Because some features of DC-DC converters are mutually exclusive: a DC-DC converter is impossible to have a high efficiency and a high frequency at the same time. The COT is suitable for the photovoltaic, wind energy and electric vehicles. The QRC and the PSC are suitable for UHF DC-DC converter with a low power. The ZVT/ZCT DC-DC converter cannot be used in a very high frequency application. Because its auxiliary circuit increases the design difficulty during high-frequency operations. In practice applications, we can choose soft-switching DC-DC converters based on these features.

Now soft-switching DC-DC converters are already very rich, and new soft-switching converters are constantly emerging. However, the most basic soft-switching technology has appeared more than ten years ago. In recent years, although new soft-switching topologies have been continuously proposed, no new soft-switching technology has been found. In order to provide a solid foundation for the emergence of new soft-switching technology, promote the proposal of a unified construction method for soft-switching DC-DC converters, and developing the computer-aided soft-switching DC-DC automatic construction technology, we summarized several basic soft-switching DC-DC converter constitution methods based on existing soft-switching converters as:

(1) Theoretical constitution method. In FIGURE 1, we give several main soft-switching forms, soft-switching structure foundations, and operating principles of the switching unit. All methods (include control strategies and auxiliary circuits) that can generate these waveforms will obtain soft-switching conditions. Therefore the basic theoretical constitution method is to directly design control methods or auxiliary circuits to implement these waveforms;

(2) Promote to other converters. Most soft-switching technologies are universal, and can be promoting to other

non-isolated DC-DC converters, isolated DC-DC converters, even inverters;

(3) Family expansion. By changing connecting locations of the auxiliary circuits, a family of this type soft-switching converter can be obtained to satisfy different configuration requirement in practice applications;

(4) Performance improvement. By adding or deleting components, and introducing magnetic coupling, the original soft-switching converters will be improved at efficiency, current ripples or other aspect.

D. FUTURE TRENDS

In industrial applications, soft-switching technologies have been widely used. Until now, basic theory and topology of soft-switching technologies are already relatively complete. And soft-switching technologies are gaining more and more widespread application such as electric vehicles, power systems, consumer electronics, etc. In recent years, basic soft-switching technologies have stalled, and there are no new soft-switching technologies appeared. From the analysis of the basic realization principle of soft-switching, the basic theory and method of the soft-switching technology are relatively complete at present. In our opinion, future work is mainly to discover more soft-switching converters based on existing technologies, and to promote the further application of soft-switching technologies in various converters. Meanwhile we hope that the comprehensive summary of soft-switching technologies in this paper will provide theory basics for the exploration and discovery of new soft-switching technologies in the future.

More concretely, in the future, soft-switching technologies will continue developing in the following areas:

(1) Exploration and discovery of new soft-switching technologies. Although the soft-switching technology is relatively complete, it is still expected that the new soft-switching technology will be discovered. Since the current

soft-switching technology cannot solve the switching loss of some converters under extreme working conditions (such as low-voltage and high-current converters).

(2) Soft-switching topology construction methods based on general principle of soft-switching technologies. Guipeng Chen et al [55], [78] already do some works on the same type of soft-switching topology deduction to get all possible similar topologies. Furthermore he proposed an equivalent converter identification method with computer aided to eliminate equivalent topologies and repeat researches [152]. More general soft-switching topology deduction methods are looking forward in the future. In addition, the deductive algorithm of new soft-switching DC-DC converters based on existing soft-switching technologies and the computer-aided technology is also a key technology for the development of the future soft-switching technology. Computer-aided deduction algorithms can not only eliminate the repeated research of equivalent converters, but also discover a large number of new soft-switching converters in a short time through automated performance and verification methods, which greatly reduces the workload of soft-switching technology researchers;

(3) Soft-switching technology applications on special DC-DC converters and actual industrial applications. Although existing soft-switching converters are already very rich, Soft-switching technologies for special DC-DC converters (such as multiphase DC-DC converters, cascade DC-DC converters, multilevel DC-DC converters, and so on) and special applications (such as photovoltaic power generation systems, fuel cells, electric vehicles, and so on) lack enough attention and research. At present, most academic researches on the soft-switching technology are based on low-power converters (usually less than 1kW). The research results and conclusions cannot be directly applied to industrial practice. Therefore, further research on the industrial application of the soft-switching technology is needed;

(4) Advanced control modulation technologies for soft-switching DC-DC converters. Although most of researchers will give the basic control method for the new soft-switching DC-DC converters when it is proposed, the performance of this control method will be not the best. The performance of the proposed soft-switching DC-DC converter cannot be fully utilized. In addition, for different application scenarios, corresponding control strategies need to be designed. With the development of the computer technology, the occupancy of computing resources by the complex modulation behavior is no longer limiting condition. Therefore advanced control modulation technologies for not only control-only soft-switching DC-DC converters but also all other soft-switching DC-DC converters should be deeply researched based on switching behavior modulations and modern control theory methods.

VII. CONCLUSION AND DISCUSS

So far there is not a paper given an overview review of all soft-switching technologies for non-isolated DC-DC converters.

Therefore this paper gives this overview review to organize the entire soft-switching technologies and their development context. Though introducing each soft-switching technology with typical converter topologies in detail, features of every soft-switching technology, soft-switching topology constitution method and future trends are also presented. In addition, through the summary of all soft-switching technologies and new soft-switching DC-DC converters, this article attempts to provide a theoretical basis for the exploration and discovery of new soft-switching technologies, provide research ideas for soft-switching technology researchers, and provide guidance on the discovery and application of soft-switching converters, thereby promoting the development and further industrial applications of soft-switching technologies. We believe that soft-switching technologies will obtain a more widely application in the future.

REFERENCES

- [1] Z. Wang and J. Liu, *Power Electronics*, 5th ed. Beijing, China: Machinery Industry Press, 2009.
- [2] Y. Chen, X. Liang, and J. Zhou, "Summary of topological structure of the bidirectional DC-DC converter," *Electr. Autom.*, vol. 39, no. 6, pp. 1-6, Jun. 2017.
- [3] Y. Xiong, S. Sun, H. Jia, P. Shea, and Z. J. Shen, "New physical insights on power MOSFET switching losses," *IEEE Trans. Power Electron.*, vol. 24, no. 2, pp. 525-531, Feb. 2009.
- [4] Y. L. Gu, S. J. Chen, Z. Y. Lu, and Z. M. Qian, "Strategy for control type soft switching converters," *Proc. CSEE*, vol. 25, no. 6, pp. 58-62, Jun. 2005.
- [5] A. Rodriguez, A. Vazquez, M. R. Rogina, and F. Briz, "Synchronous boost converter with high efficiency at light load using QSW-ZVS and SiC MOSFETs," *IEEE Trans. Ind. Electron.*, vol. 65, no. 1, pp. 386-393, Jan. 2018.
- [6] G. Hua and F. C. Lee, "Soft-switching techniques in PWM converters," *IEEE Trans. Ind. Electron.*, vol. 42, no. 6, pp. 595-603, Dec. 1995.
- [7] Z. Yu, H. Kapels, and K. F. Hoffmann, "A novel control concept for high-efficiency power conversion with the bidirectional non-inverting buck-boost converter," in *Proc. 18th Eur. Conf. Power Electron. Appl. (EPE ECCE Europe)*, Karlsruhe, Germany, Sep. 2016, pp. 1-10.
- [8] Z. Zhou, H. Li, and X. Wu, "A constant frequency ZVS control system for the four-switch buck-boost DC-DC converter with reduced inductor current," *IEEE Trans. Power Electron.*, vol. 34, no. 7, pp. 5996-6003, Jul. 2019.
- [9] S. Waffler and J. W. Kolar, "A novel low-loss modulation strategy for high-power bidirectional buck + boost converters," *IEEE Trans. Power Electron.*, vol. 24, no. 6, pp. 1589-1599, Jun. 2009.
- [10] J. Yu, M. Liu, D. Song, J. Yang, and M. Su, "A soft-switching control for cascaded buck-boost converters without zero-crossing detection," *IEEE Access*, vol. 7, pp. 32522-32536, Mar. 2019.
- [11] K.-H. Liu, R. Oruganti, and F. C. Y. Lee, "Quasi-resonant converters-topologies and characteristics," *IEEE Trans. Power Electron.*, vol. PE-2, no. 1, pp. 62-71, Jan. 1987.
- [12] K.-H. Liu and F. C. Y. Lee, "Zero-voltage switching technique in DC/DC converters," *IEEE Trans. Power Electron.*, vol. 5, no. 3, pp. 293-304, Jul. 1990.
- [13] F. C. Lee, "High-frequency quasi-resonant converter technologies," *Proc. IEEE*, vol. 76, no. 4, pp. 377-390, Apr. 1988.
- [14] B.-T. Lin and Y.-S. Lee, "A unified approach to modeling, synthesizing, and analyzing quasi-resonant converters," *IEEE Trans. Power Electron.*, vol. 12, no. 6, pp. 983-992, Nov. 1997.
- [15] W. A. Tabisz and F. C. Lee, "Principles of quasi- and multi-resonant power conversion techniques," in *Proc. IEEE Int. Symp. Circuits Syst.*, vol. 2, Jun. 1991, pp. 1053-1056.
- [16] Z. R. Martinez and B. Ray, "Bidirectional DC/DC power conversion using constant frequency multi-resonant topology," in *Proc. IEEE Appl. Power Electron. Conf. Expo. (ASPEC)*, vol. 2, Feb. 1994, pp. 991-997.

- [17] B. Ray and A. Romney-Diaz, "Constant frequency resonant topologies for bidirectional DC/DC power conversion," in *Proc. IEEE Power Electron. Spec. Conf. (PESC)*, Jun. 1993, pp. 1031–1037.
- [18] B. Ray, "Bidirectional DC/DC power conversion using constant-frequency quasi-resonant topology," in *Proc. IEEE Int. Symp. Circuits Syst.*, vol. 4, May 1993, pp. 2347–2350.
- [19] Y.-S. Lee and G.-T. Cheng, "Quasi-resonant zero-current-switching bidirectional converter for battery equalization applications," *IEEE Trans. Power Electron.*, vol. 21, no. 5, pp. 1213–1224, Sep. 2006.
- [20] D.-Y. Jung, S.-H. Hwang, Y.-H. Ji, J.-H. Lee, Y.-C. Jung, and C.-Y. Won, "Soft-switching bidirectional DC/DC converter with a LC series resonant circuit," *IEEE Trans. Power Electron.*, vol. 28, no. 4, pp. 1680–1690, Apr. 2013.
- [21] S. Sharifi and M. Jabbari, "Family of single-switch quasi-resonant converters with reduced inductor size," *IET Power Electron.*, vol. 7, no. 10, pp. 2544–2554, Oct. 2014.
- [22] S. Sharifi, M. Jabbari, and H. Farzanehfar, "A new family of single-switch ZVS resonant converters," *IEEE Trans. Ind. Electron.*, vol. 64, no. 6, pp. 4539–4548, Jun. 2017.
- [23] M. R. Amini and H. Farzanehfar, "Switched resonator DC/DC converter with a single switch and small inductors," *IET Power Electron.*, vol. 7, no. 6, pp. 1331–1339, Jun. 2014.
- [24] A. Emrani, M. R. Amini, and H. Farzanehfar, "Soft single switch resonant buck converter with inherent PFC feature," *IET Power Electron.*, vol. 6, no. 3, pp. 516–522, Mar. 2013.
- [25] C.-J. Tseng and C.-L. Chen, "A passive lossless snubber cell for nonisolated PWM DC/DC converters," *IEEE Trans. Ind. Electron.*, vol. 45, no. 4, pp. 593–601, Aug. 1998.
- [26] C. Chen and C. Tseng, "Passive lossless snubbers for DC/DC converters," *IEE Proc.-Circuits, Devices Syst.*, vol. 145, no. 6, pp. 396–401, Dec. 1998.
- [27] K. Fujiwara and H. Nomura, "A novel lossless passive snubber for soft-switching boost-type converters," *IEEE Trans. Power Electron.*, vol. 14, no. 6, pp. 1065–1069, Nov. 1999.
- [28] S. Pattnaik, A. K. Panda, and K. Mahapatra, "Efficiency improvement of synchronous buck converter by passive auxiliary circuit," *IEEE Trans. Ind. Appl.*, vol. 46, no. 6, pp. 2511–2517, Nov. 2010.
- [29] R. T. H. Li, H. S.-H. Chung, and A. K. T. Sung, "Passive lossless snubber for boost PFC with minimum voltage and current stress," *IEEE Trans. Power Electron.*, vol. 25, no. 3, pp. 602–613, Mar. 2010.
- [30] H.-J. Choe, Y.-C. Chung, C.-H. Sung, J.-J. Yun, and B. Kang, "Passive snubber for reducing switching-power losses of an IGBT in a DC–DC boost converter," *IEEE Trans. Power Electron.*, vol. 29, no. 12, pp. 6332–6341, Dec. 2014.
- [31] T. Shamsi, M. Delshad, E. Adib, and M. R. Yazdani, "A new simple-structure passive lossless snubber for DC–DC boost converters," *IEEE Trans. Ind. Electron.*, vol. 68, no. 3, pp. 2207–2214, Mar. 2021.
- [32] X. Yu, J. Su, S. Guo, S. Zhong, Y. Shi, and J. Lai, "Properties and synthesis of lossless snubbers and passive soft-switching PWM converters," *IEEE Trans. Power Electron.*, vol. 35, no. 4, pp. 3807–3827, Apr. 2020.
- [33] E. Gerami, M. Delshad, M. R. Amini, and M. R. Yazdani, "A new family of non-isolated PWM DC–DC converter with soft switching," *IET Power Electron.*, vol. 12, no. 2, pp. 237–244, Feb. 2019.
- [34] P. J. M. Menegaz, J. L. F. Vieira, and D. S. L. Simonetti, "A magnetically coupled regenerative turn-on and turn-off snubber configuration," *IEEE Trans. Ind. Electron.*, vol. 47, no. 4, pp. 722–728, Aug. 2000.
- [35] Y. Konishi and Y. F. Huang, "Soft-switching buck boost converter using pulse current regenerative resonant snubber," *Electron. Lett.*, vol. 43, no. 2, pp. 127–128, Jan. 2007.
- [36] M. Esteki, M. Mohammadi, M. R. Yazdani, E. Adib, and H. Farzanehfar, "Family of soft-switching pulse-width modulation converters using coupled passive snubber," *IET Power Electron.*, vol. 10, no. 7, pp. 792–800, Jun. 2017.
- [37] M. R. Mohammadi, H. Farzanehfar, and E. Adib, "Soft-switching bidirectional buck/boost converter with a lossless passive snubber," *IEEE Trans. Ind. Electron.*, vol. 67, no. 10, pp. 8363–8370, Oct. 2020.
- [38] B. Wang, T. Q. Zheng, and J. Zhang, "Further reduction of switching loss for the lossless snubber based converters," in *Proc. IEEE Energy Convers. Congr. Expo. (ECCE)*, Sep. 2014, pp. 928–934.
- [39] T. Zhan, Y. Zhang, J. Nie, Y. Zhang, and Z. Zhao, "A novel soft-switching boost converter with magnetically coupled resonant snubber," *IEEE Trans. Power Electron.*, vol. 29, no. 11, pp. 5680–5687, Nov. 2014.
- [40] M. Khalilian, E. Adib, and H. Farzanehfar, "Family of single-switch soft-switching pulse-width modulation DC–DC converters with reduced switch stress," *IET Power Electron.*, vol. 7, no. 8, pp. 2182–2189, Aug. 2014.
- [41] M. Mohammadi, E. Adib, and M. R. Yazdani, "Family of soft-switching single-switch PWM converters with lossless passive snubber," *IEEE Trans. Ind. Electron.*, vol. 62, no. 6, pp. 3473–3481, Jun. 2015.
- [42] M. R. Amini and H. Farzanehfar, "Novel family of PWM soft-single-switched DC–DC converters with coupled inductors," *IEEE Trans. Ind. Electron.*, vol. 56, no. 6, pp. 2108–2114, Jun. 2009.
- [43] B. H. Choi, E. S. Lee, J. H. Kim, and C. T. Rim, "DCM analysis of single-switch-based ZVZCS converters with a tapped inductor," *IEEE Trans. Power Electron.*, vol. 30, no. 12, pp. 6617–6627, Dec. 2015.
- [44] B. H. Choi, S. W. Lee, V. X. Thai, and C. T. Rim, "A novel single-SiC-switch-based ZVZCS tapped boost converter," *IEEE Trans. Power Electron.*, vol. 29, no. 10, pp. 5181–5194, Oct. 2014.
- [45] J.-G. Kim, S.-W. Park, Y.-H. Kim, Y.-C. Jung, and C.-Y. Won, "High-efficiency bidirectional soft switching DC–DC converter," in *Proc. Int. Power Electron. Conf. (ECCE ASIA)*, Jun. 2010, pp. 2905–2911.
- [46] M.-N. Kim, Y.-S. Noh, J.-G. Kim, Y.-C. Jung, and C.-Y. Won, "Active power decoupling using bi-directional resonant converter for flyback inverter without electrolytic capacitor of PV AC module system," in *Proc. Int. Conf. Electr. Mach. Syst. (ICEMS)*, Oct. 2013, pp. 351–356.
- [47] H.-L. Do, "Nonisolated bidirectional zero-voltage-switching DC–DC converter," *IEEE Trans. Power Electron.*, vol. 26, no. 9, pp. 2563–2569, Sep. 2011.
- [48] Z. Weiping, X. Zhang, and S. Xiao, "A novel soft switch for buck converter," in *Proc. 2nd Int. Symp. Power Electron. Distrib. Gener. Syst.*, Jun. 2010, pp. 180–184.
- [49] I.-H. Oh, "A soft-switching synchronous buck converter for zero voltage switching (ZVS) in light and full load conditions," in *Proc. 23rd Annu. IEEE Appl. Power Electron. Conf. Expo.*, Feb. 2008, pp. 1460–1464.
- [50] Y. Zhang, X.-F. Cheng, C. Yin, and S. Cheng, "Analysis and research of a soft-switching bidirectional DC–DC converter without auxiliary switches," *IEEE Trans. Ind. Electron.*, vol. 65, no. 2, pp. 1196–1204, Feb. 2018.
- [51] S. M. Venkit and P. C. Athira, "Solar powered ZCS bidirectional buck-boost converter used in battery energy storage systems," in *Proc. Int. Conf. Circuit, Power Comput. Technol. (ICCPCT)*, Mar. 2016, pp. 1–5.
- [52] G. R. Broday, C. B. Nascimento, L. A. C. Lopes, and E. Agostini, "Analysis and simulation of a buck-boost operation in a bidirectional ZVS DC–DC converter," in *Proc. Int. Conf. Electr. Syst. Aircr., Railway, Ship Propuls. Road Vehicles Int. Transp. Electrific. Conf. (ESARS-ITEC)*, Nov. 2016, pp. 1–7.
- [53] Y. Zhang and P. C. Sen, "A new soft-switching technique for buck, boost, and buck-boost converters," *IEEE Trans. Ind. Appl.*, vol. 39, no. 6, pp. 1775–1782, Nov./Dec. 2003.
- [54] H.-L. Do, "Zero-voltage-switching synchronous buck converter with a coupled inductor," *IEEE Trans. Ind. Electron.*, vol. 58, no. 8, pp. 3440–3447, Aug. 2011.
- [55] G. Chen, Y. Deng, Y. Tao, X. He, Y. Wang, and Y. Hu, "Topology derivation and generalized analysis of zero-voltage-switching synchronous DC–DC converters with coupled inductors," *IEEE Trans. Ind. Electron.*, vol. 63, no. 8, pp. 4805–4815, Aug. 2016.
- [56] L. Jiang, C. C. Mi, S. Li, C. Yin, and J. Li, "An improved soft-switching buck converter with coupled inductor," *IEEE Trans. Power Electron.*, vol. 28, no. 11, pp. 4885–4891, Nov. 2013.
- [57] Y. Berkovich and B. Axelrod, "Switched-coupled inductor cell for DC–DC converters with very large conversion ratio," *IET Power Electron.*, vol. 4, no. 3, pp. 309–315, Apr. 2011.
- [58] X. Zhang, L. Jiang, J. Deng, S. Li, and Z. Chen, "Analysis and design of a new soft-switching boost converter with a coupled inductor," *IEEE Trans. Power Electron.*, vol. 29, no. 8, pp. 4270–4277, Aug. 2014.
- [59] X.-F. Cheng, Y. Zhang, and C. Yin, "A zero voltage switching topology for non-inverting buck–boost converter," *IEEE Trans. Circuits Syst. II, Exp. Briefs*, vol. 66, no. 9, pp. 1557–1561, Sep. 2019.
- [60] Y. Zhang, X.-F. Cheng, and C. Yin, "A soft-switching non-inverting buck–boost converter with efficiency and performance improvement," *IEEE Trans. Power Electron.*, vol. 34, no. 12, pp. 11526–11530, Dec. 2019.
- [61] Z. Zhao, X. G. Xie, Y. Ma, and Z. M. Qian, "Investigation of an 1 MHz ZVS synchronous buck converter," *Power Electron.*, vol. 40, no. 2, pp. 51–53, Feb. 2006.

- [62] X.-F. Cheng, Y. Zhang, and C. Yin, "A family of coupled-inductor-based soft-switching DC-DC converter with double synchronous rectification," *IEEE Trans. Ind. Electron.*, vol. 66, no. 9, pp. 6936-6946, Sep. 2019.
- [63] L. Jiang, C. Chris Mi, S. Li, M. Zhang, X. Zhang, and C. Yin, "A novel soft-switching bidirectional DC-DC converter with coupled inductors," *IEEE Trans. Ind. Appl.*, vol. 49, no. 6, pp. 2730-2740, Dec. 2013.
- [64] Y. Zhang, X. Cheng, C. Yin, and S. Cheng, "A soft-switching bidirectional DC-DC converter for the battery super-capacitor hybrid energy storage system," *IEEE Trans. Ind. Electron.*, vol. 65, no. 10, pp. 7856-7865, Oct. 2018.
- [65] X.-F. Cheng, Y. Zhang, and C. Yin, "A ZVS bidirectional inverting buck-boost converter using coupled inductors," *Electronics*, vol. 7, no. 10, p. 221, Sep. 2018.
- [66] K.-H. Chao and C.-H. Huang, "Bidirectional DC-DC soft-switching converter for stand-alone photovoltaic power generation systems," *IET Power Electron.*, vol. 7, no. 6, pp. 1557-1565, Jun. 2014.
- [67] I.-H. Lee, J.-G. Kim, T.-G. Lee, Y.-C. Jung, and C.-Y. Won, "A new bidirectional DC-DC converter with ZVT switching," in *Proc. IEEE Vehicle Power Propuls. Conf.*, Oct. 2012, pp. 684-689.
- [68] M. R. Mohammadi and H. Farzanehfar, "New family of zero-voltage-transition PWM bidirectional converters with coupled inductors," *IEEE Trans. Ind. Electron.*, vol. 59, no. 2, pp. 912-919, Feb. 2012.
- [69] M. R. Mohammadi and H. Farzanehfar, "A bidirectional zero voltage transition converter with coupled inductors," in *Proc. IEEE Int. Conf. Power Energy*, Nov. 2010, pp. 57-62.
- [70] J.-H. Lee, D.-H. Yu, J.-G. Kim, Y.-H. Kim, S.-C. Shin, D.-Y. Jung, Y.-C. Jung, and C.-Y. Won, "Auxiliary switch control of a bidirectional soft-switching DC/DC converter," *IEEE Trans. Power Electron.*, vol. 28, no. 12, pp. 5446-5457, Dec. 2013.
- [71] M. R. Mohammadi and H. Farzanehfar, "A new family of zero-voltage-transition nonisolated bidirectional converters with simple auxiliary circuit," *IEEE Trans. Ind. Electron.*, vol. 63, no. 3, pp. 1519-1527, Mar. 2016.
- [72] H.-C. Choi, "A novel buck converter with soft-switching transition," *Int. J. Electron.*, vol. 89, no. 3, pp. 221-232, Mar. 2002.
- [73] E. Adib and H. Farzanehfar, "Zero-voltage-transition PWM converters with synchronous rectifier," *IEEE Trans. Power Electron.*, vol. 25, no. 1, pp. 105-110, Jan. 2010.
- [74] M. R. Mohammadi and H. Farzanehfar, "Analysis of diode reverse recovery effect on the improvement of soft-switching range in zero-voltage-transition bidirectional converters," *IEEE Trans. Ind. Electron.*, vol. 62, no. 3, pp. 1471-1479, Mar. 2015.
- [75] H. Farzanehfar, D. S. Beyragh, and E. Adib, "A bidirectional soft switched ultracapacitor interface circuit for hybrid electric vehicles," *Energy Convers. Manage.*, vol. 49, no. 12, pp. 3578-3584, Dec. 2008.
- [76] A. Rahimi and M. R. Mohammadi, "Zero-voltage-transition synchronous DC-DC converters with coupled inductors," *J. Power Electron.*, vol. 16, pp. 74-83, Feb. 2016.
- [77] G. Chen, J. Dong, Y. Deng, Y. Tao, X. He, and Y. Wang, "A family of magnetic coupling DC-DC converters with zero-voltage-switching over wide input voltage range and load variation," *J. Power Electron.*, vol. 16, no. 5, pp. 1639-1649, Sep. 2016.
- [78] G. Chen, Y. Deng, L. Chen, Y. Hu, L. Jiang, X. He, and Y. Wang, "A family of zero-voltage-switching magnetic coupling nonisolated bidirectional DC-DC converters," *IEEE Trans. Ind. Electron.*, vol. 64, no. 8, pp. 6223-6233, Aug. 2017.
- [79] G. Hua, C.-S. Leu, Y. Jiang, and F. C. Y. Lee, "Novel zero-voltage-transition PWM converters," *IEEE Trans. Power Electron.*, vol. 9, no. 2, pp. 213-219, Mar. 1994.
- [80] M. R. Mohammadi, H. Peyman, M. R. Yazdani, and S. M. M. Mirtalaei, "A ZVT bidirectional converter with coupled-filter-inductor and elimination of input current notches," *IEEE Trans. Ind. Electron.*, vol. 67, no. 9, pp. 7461-7469, Sep. 2020.
- [81] J.-W. Yang and H.-L. Do, "High-efficiency bidirectional DC-DC converter with low circulating current and ZVS characteristic throughout a full range of loads," *IEEE Trans. Ind. Electron.*, vol. 61, no. 7, pp. 3248-3256, Jul. 2014.
- [82] X. Zhang, W. Qian, and Z. Li, "Design and analysis of a novel ZVZCT boost converter with coupling effect," *IEEE Trans. Power Electron.*, vol. 32, no. 12, pp. 8992-9000, Dec. 2017.
- [83] S. Oh, J. Kim, J. Kim, C. Won, and Y. Jung, "Analysis of a novel soft switching bidirectional DC-DC converter," *J. Power Electron.*, vol. 12, pp. 2154-2159, May 2011.
- [84] M. Pavlovský, G. Guidi, and A. Kawamura, "Buck/boost DC-DC converter topology with soft switching in the whole operating region," *IEEE Trans. Power Electron.*, vol. 29, no. 2, pp. 851-862, Feb. 2014.
- [85] M. R. Mohammadi and H. Farzanehfar, "Family of soft-switching bidirectional converters with extended ZVS range," *IEEE Trans. Ind. Electron.*, vol. 64, no. 9, pp. 7000-7008, Sep. 2017.
- [86] E. Adib and H. Farzanehfar, "Family of zero-voltage transition pulse width modulation converters with low auxiliary switch voltage stress," *IET Power Electron.*, vol. 4, no. 4, pp. 447-453, Apr. 2011.
- [87] H. N. Tran and S. Choi, "A family of ZVT DC-DC converters with low-voltage ringing," *IEEE Trans. Power Electron.*, vol. 35, no. 1, pp. 59-69, Jan. 2020.
- [88] A. Mirzaei, A. Jusoh, Z. Salam, E. Adib, and H. Farzanehfar, "Analysis and design of a high efficiency bidirectional DC-DC converter for battery and ultracapacitor applications," *Simul. Model. Pract. Theory*, vol. 19, no. 7, pp. 1651-1667, Jul. 2011.
- [89] A. Mirzaei, A. Jusoh, and Z. Salam, "Design and implementation of high efficiency non-isolated bidirectional zero voltage transition pulse width modulated DC-DC converters," *Energy*, vol. 47, no. 1, pp. 358-369, Nov. 2012.
- [90] A. Mirzaei, A. Jusoh, Z. Salam, E. Adib, and H. Farzanehfar, "A novel soft switching bidirectional coupled inductor buck-boost converter for battery discharging-charging," in *Proc. IEEE Appl. Power Electron. Colloq. (IAPEC)*, Apr. 2011, pp. 195-199.
- [91] M. Rezvanyvardom and A. Mirzaei, "Zero-voltage transition nonisolated bidirectional buck-boost DC-DC converter with coupled inductors," *IEEE J. Emerg. Sel. Topics Power Electron.*, vol. 9, no. 3, pp. 3266-3275, Jun. 2021.
- [92] P. Das, B. Laan, S. A. Mousavi, and G. Moschopoulos, "A nonisolated bidirectional ZVS-PWM active clamped DC-DC converter," *IEEE Trans. Power Electron.*, vol. 24, no. 2, pp. 553-558, Feb. 2009.
- [93] P. Das, S. A. Mousavi, and G. Moschopoulos, "Analysis and design of a nonisolated bidirectional ZVS-PWM DC-DC converter with coupled inductors," *IEEE Trans. Power Electron.*, vol. 25, no. 10, pp. 2630-2641, Oct. 2010.
- [94] G. Hua, E. X. Yang, Y. Jiang, and F. C. Lee, "Novel zero-current-transition PWM converters," *IEEE Trans. Power Electron.*, vol. 9, no. 6, pp. 601-606, Nov. 1994.
- [95] D.-Y. Lee, M.-K. Lee, D.-S. Hyun, and I. Choy, "New zero-current-transition PWM DC/DC converters without current stress," *IEEE Trans. Power Electron.*, vol. 18, no. 1, pp. 95-104, Jan. 2003.
- [96] E. Adib and H. Farzanehfar, "Family of zero-current transition PWM converters," *IEEE Trans. Ind. Electron.*, vol. 55, no. 8, pp. 3055-3063, Aug. 2008.
- [97] M. Ahmadi, M. R. Mohammadi, E. Adib, and H. Farzanehfar, "Family of non-isolated zero current transition bi-directional converters with one auxiliary switch," *IET Power Electron.*, vol. 5, no. 2, pp. 158-165, Feb. 2012.
- [98] M. R. Yazdani, M. P. Dust, and P. Hemmati, "A new family of non-isolated zero-current transition PWM converters," *J. Power Electron.*, vol. 16, no. 5, pp. 1669-1677, Sep. 2016.
- [99] P. Das and G. Moschopoulos, "A comparative study of zero-current-transition PWM converters," *IEEE Trans. Ind. Electron.*, vol. 54, no. 3, pp. 1319-1328, Jun. 2007.
- [100] H. Bodur and A. F. Bakan, "An improved ZCT-PWM DC-DC converter for high-power and frequency applications," *IEEE Trans. Ind. Electron.*, vol. 51, no. 1, pp. 89-95, Feb. 2004.
- [101] S. Urgun, "Zero-voltage transition-zero-current transition pulsewidth modulation DC-DC buck converter with zero-voltage switching? Zero-current switching auxiliary circuit," *IET Power Electron.*, vol. 5, no. 5, pp. 627-634, May 2012.
- [102] N. Altıntaş, A. F. Bakan, and İ. Aksoy, "A novel ZVT-ZCT-PWM boost converter," *IEEE Trans. Power Electron.*, vol. 29, no. 1, pp. 256-265, Jan. 2014.
- [103] I. Aksoy, H. Bodur, and A. F. Bakan, "A new ZVT-ZCT-PWM DC-DC converter," *IEEE Trans. Power Electron.*, vol. 25, no. 8, pp. 2093-2105, Aug. 2010.
- [104] H. Bodur and A. F. Bakan, "A new ZVT-ZCT-PWM DC-DC converter," *IEEE Trans. Power Electron.*, vol. 19, no. 3, pp. 676-684, May 2004.
- [105] B. Akin, "An improved ZVT-ZCT PWM DC-DC boost converter with increased efficiency," *IEEE Trans. Power Electron.*, vol. 29, no. 4, pp. 1919-1926, Apr. 2014.

- [106] A. Mirzaei, H. Farzanehfard, E. Adib, A. Jusoh, and Z. Salam, "A fully soft switched two quadrant bidirectional soft switching converter for ultra capacitor interface circuits," *J. Power Electron.*, vol. 11, no. 1, pp. 1–9, Jan. 2011.
- [107] I. Barbi, J. C. O. Bolacell, D. C. Martins, and F. B. Libano, "Buck quasi-resonant converter operating at constant frequency: Analysis, design, and experimentation," *IEEE Trans. Power Electron.*, vol. 5, no. 3, pp. 276–283, Jul. 1990.
- [108] M. Jabbari and H. Farzanehfard, "Family of soft-switching resonant DC-DC converters," *IET Power Electron.*, vol. 2, no. 2, pp. 113–124, Mar. 2009.
- [109] A. Emrani and H. Farzanehfard, "Zero-current switching resonant buck converters with small inductors," *IET Power Electron.*, vol. 5, no. 6, pp. 710–718, Jul. 2012.
- [110] M. Jabbari, N. H. Najafabadi, G. Shahgholian, and M. Mahdavian, "A novel resonant LLC soft-switching inverting-buck converter," in *Proc. 10th Int. Conf. Electr. Eng./Electron., Comput., Telecommun. Inf. Technol.*, May 2013, pp. 1–6.
- [111] A. Ray and D. Kasta, "Three switch cell soft-switching resonant buck converter for point-of-load application," in *Proc. 3rd Int. Conf. Comput. Intell. Inf. Technol. (CIIT)*, 2013, pp. 134–140.
- [112] T. Q. Zheng, T. Shao, N. Han, Y. Li, and J. Liu, "Current adaptive resonant loop soft switching PWM converters," in *Proc. IEEE Appl. Power Electron. Conf. Expo. (APEC)*, Mar. 2014, pp. 2061–2066.
- [113] A. Elasser and D. A. Torrey, "Soft switching active snubbers for DC/DC converters," *IEEE Trans. Power Electron.*, vol. 11, no. 5, pp. 710–722, Sep. 1996.
- [114] B. P. Divakar, K. W. E. Cheng, and D. Sutanto, "Zero-voltage and zero-current switching buck-boost converter with low voltage and current stresses," *IET Power Electron.*, vol. 1, no. 3, pp. 297–304, Sep. 2008.
- [115] Y. Jang and M. M. Jovanovic, "Soft-switched bidirectional buck-boost converters," in *Proc. IEEE Appl. Power Electron. Conf. Expo. (APEC)*, Mar. 2017, pp. 287–293.
- [116] M. M. Jovanovic and Y. Jang, "A new, soft-switched boost converter with isolated active snubber," *IEEE Trans. Ind. Appl.*, vol. 35, no. 2, pp. 496–502, Mar./Apr. 1999.
- [117] B. Ivanovic and Z. Stojiljkovic, "A novel active soft switching snubber designed for boost converter," *IEEE Trans. Power Electron.*, vol. 19, no. 3, pp. 658–665, May 2004.
- [118] J. Y. Zhu and D. Ding, "Zero-voltage- and zero-current-switched PWM DC-DC converters using active snubber," *IEEE Trans. Ind. Appl.*, vol. 35, no. 6, pp. 1406–1412, Nov./Dec. 1999.
- [119] J.-W. Yang and H.-L. Do, "Soft-switching bidirectional DC-DC converter using a lossless active snubber," *IEEE Trans. Circuits Syst. I, Reg. Papers*, vol. 61, no. 5, pp. 1588–1596, May 2014.
- [120] D.-K. Kwak, S.-H. Lee, and D.-Y. Jung, "A new buck-boost DC/DC converter of high efficiency by soft switching technique," in *Proc. IEEE 6th Int. Power Electron. Motion Control Conf.*, May 2009, pp. 1295–1299.
- [121] J. Zhang, J.-S. Lai, R.-Y. Kim, and W. Yu, "High-power density design of a soft-switching high-power bidirectional DC-DC converter," *IEEE Trans. Power Electron.*, vol. 22, no. 4, pp. 1145–1153, Jul. 2007.
- [122] M. Pajnic and P. Pejovic, "Zero-voltage switching control of an interleaved bi-directional buck-boost converter with variable coupled inductor," *IEEE Trans. Power Electron.*, vol. 34, no. 10, pp. 9562–9572, Oct. 2019.
- [123] J.-G. Cho, J.-W. Baek, G.-H. Rim, and I. Kang, "Novel zero-voltage-transition PWM multiphase converters," *IEEE Trans. Power Electron.*, vol. 13, no. 1, pp. 152–159, Jan. 1998.
- [124] Y. Hsieh, T. Hsueh, and H. Yen, "An interleaved boost converter with zero-voltage transition," *IEEE Trans. Power Electron.*, vol. 24, no. 4, pp. 973–978, Apr. 2009.
- [125] E. Maali and B. Vahidi, "Double-deck buck-boost converter with soft switching operation," *IEEE Trans. Power Electron.*, vol. 31, no. 6, pp. 4324–4330, Jun. 2016.
- [126] T. Rahimi, S. H. Hosseini, M. Sabahi, M. Abapour, and G. B. Gharehpetian, "Three-phase soft-switching-based interleaved boost converter with high reliability," *IET Power Electron.*, vol. 10, no. 3, pp. 377–386, Mar. 2017.
- [127] F. Marvi, E. Adib, and H. Farzanehfard, "Efficient ZVS synchronous buck converter with extended duty cycle and low-current ripple," *IEEE Trans. Ind. Electron.*, vol. 63, no. 9, pp. 5403–5409, Sep. 2016.
- [128] J.-H. Yi, W. Choi, and B.-H. Cho, "Zero-voltage-transition interleaved boost converter with an auxiliary coupled inductor," *IEEE Trans. Power Electron.*, vol. 32, no. 8, pp. 5917–5930, Aug. 2017.
- [129] Y.-T. Chen, Z.-M. Li, and R.-H. Liang, "A novel soft-switching interleaved coupled-inductor boost converter with only single auxiliary circuit," *IEEE Trans. Power Electron.*, vol. 33, no. 3, pp. 2267–2281, Mar. 2018.
- [130] Y.-T. Chen, S. Shiu, and R. Liang, "Analysis and design of a zero-voltage-switching and zero-current-switching interleaved boost converter," *IEEE Trans. Power Electron.*, vol. 27, no. 1, pp. 161–173, Jan. 2012.
- [131] B. Akhlaghi and H. Farzanehfard, "Family of ZVT interleaved converters with low number of components," *IEEE Trans. Ind. Electron.*, vol. 65, no. 11, pp. 8565–8573, Nov. 2018.
- [132] B. Akhlaghi, M. Esteki, and H. Farzanehfard, "Family of zero voltage transition interleaved converters with low voltage and current stress," *IET Power Electron.*, vol. 11, no. 12, pp. 1886–1893, Oct. 2018.
- [133] H. Tarzami, E. Babaei, A. Z. Gharehkhoushan, and M. Sabahi, "Interleaved full ZVZCS DC-DC boost converter: Analysis, design, reliability evaluations and experimental results," *IET Power Electron.*, vol. 10, no. 7, pp. 835–845, Jun. 2017.
- [134] C. Wang, C. Lin, C. Lu, and J. Li, "Design and realisation of a zero-voltage transition pulse-width modulation interleaved boost power factor correction converter," *IET Power Electron.*, vol. 8, no. 8, pp. 1542–1551, Aug. 2015.
- [135] C. Wang, C. Lin, C. Lu, and J. Li, "Analysis, design, and realisation of a ZVT interleaved boost DC/DC converter with single ZVT auxiliary circuit," *IET Power Electron.*, vol. 10, no. 14, pp. 1789–1799, Nov. 2017.
- [136] D.-Y. Jung, Y.-H. Ji, S.-H. Park, Y.-C. Jung, and C.-Y. Won, "Interleaved soft-switching boost converter for photovoltaic power-generation system," *IEEE Trans. Power Electron.*, vol. 26, no. 4, pp. 1137–1145, Apr. 2011.
- [137] G. Yao, A. Chen, and X. He, "Soft switching circuit for interleaved boost converters," *IEEE Trans. Power Electron.*, vol. 22, no. 1, pp. 80–86, Jan. 2007.
- [138] M. Rezvanyardom, E. Adib, and H. Farzanehfard, "New interleaved zero-current switching pulse-width modulation boost converter with one auxiliary switch," *IET Power Electron.*, vol. 4, no. 9, pp. 979–983, Nov. 2011.
- [139] M. Ilic and D. Maksimovic, "Interleaved zero-current-transition buck converter," *IEEE Trans. Ind. Appl.*, vol. 43, no. 6, pp. 1619–1627, Nov./Dec. 2007.
- [140] H. Bahrami, E. Adib, S. Farhangi, H. Eini, and R. Golmohammadi, "ZCS-PWM interleaved boost converter using resonance-clamp auxiliary circuit," *IET Power Electron.*, vol. 10, no. 3, pp. 405–412, Mar. 2017.
- [141] M. Rezvanyardom, E. Adib, H. Farzanehfard, and M. Mohammadi, "Analysis, design and implementation of zero-current transition interleaved boost converter," *IET Power Electron.*, vol. 5, no. 9, pp. 1804–1812, Nov. 2012.
- [142] J. Xue and H. Lee, "A 2-MHz 60-W zero-voltage-switching synchronous noninverting buck-boost converter with reduced component values," *IEEE Trans. Circuits Syst. II, Exp. Briefs*, vol. 62, no. 7, pp. 716–720, Jul. 2015.
- [143] L. Cong, J. Liu, and H. Lee, "A high-efficiency low-profile zero-voltage transition synchronous non-inverting buck-boost converter with auxiliary-component sharing," *IEEE Trans. Circuits Syst. I, Reg. Papers*, vol. 66, no. 1, pp. 438–449, Jan. 2019.
- [144] H. Yun, M. Dong, Y. Jian, J. Wan, M. Shen, and Y. Wang, "Application of soft-switching technology in four switch buck-boost circuit," in *Proc. 12th IEEE Conf. Ind. Electron. Appl. (ICIEA)*, Jun. 2017, pp. 1675–1679.
- [145] S. Waffler and J. W. Kolar, "Comparative evaluation of soft-switching concepts for bi-directional buck + boost DC-DC converters," in *Proc. Int. Power Electron. Conf. (ECCE ASIA)*, Jun. 2010, pp. 1856–1865.
- [146] P. Ranstad, H. P. Nee, J. Linnér, and D. Pefütsis, "An experimental evaluation of SiC switches in soft-switching converters," *IEEE Trans. Power Electron.*, vol. 29, no. 5, pp. 2527–2538, May 2014.
- [147] A. Jafari, M. S. Nikoo, N. Perera, H. K. Yildirim, F. Karakaya, R. Soleimanzadeh, and E. Matioli, "Comparison of wide-band-gap technologies for soft-switching losses at high frequencies," *IEEE Trans. Power Electron.*, vol. 35, no. 12, pp. 12595–12600, Dec. 2020.
- [148] M. R. Ahmed, R. Todd, and A. J. Forsyth, "Predicting SiC MOSFET behavior under hard-switching, soft-switching, and false turn-on conditions," *IEEE Trans. Ind. Electron.*, vol. 64, no. 11, pp. 9001–9011, Nov. 2017.

- [149] B. Agrawal, L. Zhou, A. Emadi, and M. Preindl, "Variable-frequency critical soft-switching of wide-bandgap devices for efficient high-frequency nonisolated DC-DC converters," *IEEE Trans. Veh. Technol.*, vol. 69, no. 6, pp. 6094–6106, Jun. 2020.
- [150] M. R. Rogina, A. Rodriguez, A. Vazquez, and D. G. Lamar, "Improving the efficiency of SiC-based synchronous boost converter under variable switching frequency TCM and different input/output voltage ratios," *IEEE Trans. Ind. Appl.*, vol. 55, no. 6, pp. 7757–7764, Nov. 2019.
- [151] R. Li, X. Wu, S. Yang, and K. Sheng, "Dynamic on-state resistance test and evaluation of GaN power devices under hard- and soft-switching conditions by double and multiple pulses," *IEEE Trans. Power Electron.*, vol. 34, no. 2, pp. 1044–1053, Feb. 2019.
- [152] G. Chen, L. Mo, Y. Liu, X. Qing, and Y. Hu, "Computer-aided identification of equivalent power electronics converters," *IEEE Trans. Power Electron.*, vol. 34, no. 10, pp. 9374–9378, Oct. 2019.



XU-FENG CHENG was born in Hebei, China, in 1986. He received the B.S. degree in mechanical design manufacture and automation from Huazhong Agricultural University, Wuhan, China, in 2011, the M.S. degree in mechatronic engineering from Northeastern University, Shenyang, China, in 2013, and the Ph.D. degree in mechanical engineering from Shanghai Jiao Tong University, Shanghai, China, in 2019.

Since 2019, he has been an Assistant Professor with the School of Mechanical Engineering, Hebei University of Science and Technology. His research interests include automotive power electronics and control, power converter soft-switching technology, special power supply technology, and integrated control of electromechanical equipment.



CHENYANG LIU was born in Xinyang, Henan, China, in 1991. He received the Ph.D. degree in electrical engineering from Xi'an Jiaotong University, Xi'an, China, in 2017. He worked as a Postdoctoral Researcher at State Grid Xuji Group Corporation, China, from 2017 to 2021. He is currently an Associate Professor with the School of Marine Electrical Engineering, Dalian Maritime University, Dalian, China. He is also the

Principal with the DC System Power Equipment Research Group of Sea and Ships, Xi'an Jiaotong University. He has participated in many UHVDC, HVDC Light, and MVDC System Project construction projects in China. Also he has undertaken or participated in more than 30 scientific research projects, such as Provincial Postdoctoral Fund, National Key Research and Development Program, and State Grid Science and Technology Project. He has authored or coauthored more than 30 SCI/EI journals or conference papers and holds five China patents. His current research interests mainly include MVDC system and equipment of ships, insulation of the DC power equipment of ships, HVDC circuit breaker, HVDC light, UHVDC converter valve, high-voltage test technology, space radiation, nonlinear conductivity insulating materials, and electrical-motor insulation.



DIANLONG WANG was born in Shandong, China, in 1978. He received the B.S. and M.S. degrees from Shenyang University of Technology, Shenyang, China, in 2000 and 2003, respectively, and the Ph.D. degree from Beihang University, Beijing, China, in 2007, all in materials science and engineering.

He is currently a Professor with the School of Materials Science and Engineering, Hebei University of Science and Technology. His research interests include special power source, light alloy hybrid arc welding technology, and welding process detection and control.



YONG ZHANG (Member, IEEE) was born in Anhui, China, in 1977. He received the B.S. and M.S. degrees from Chang'an University, Xi'an, China, in 1999 and 2002, respectively, and the Ph.D. degree from Shanghai Jiao Tong University, Shanghai, China, in 2005, all in vehicle engineering.

He is currently an Assistant Professor with the National Engineering Laboratory for Automotive Electronic Control Technology, School of Mechanical Engineering, Shanghai Jiao Tong University. His research interests include the control of automotive electronics and electric vehicles.

...