

Received April 23, 2021, accepted May 5, 2021, date of publication May 14, 2021, date of current version May 25, 2021.

Digital Object Identifier 10.1109/ACCESS.2021.3080315

# Constructing Independent Spanning Trees on Generalized Recursive Circulant Graphs

DUN-WEI CHENG<sup>1</sup>, KAI-HSUN YAO<sup>1</sup>, AND SUN-YUAN HSIEH<sup>2</sup>, (Senior Member, IEEE)

<sup>1</sup>Department of Computer Science and Information Engineering, National Cheng Kung University, Tainan 701, Taiwan

<sup>2</sup>Department of Computer Science and Information Engineering, Institute of Medical Informatics and Center for Innovative FinTech Business Models, National Cheng Kung University, Tainan 701, Taiwan

Corresponding author: Dun-Wei Cheng (dunwei.ncku@gmail.com)

This work was supported in part by the Higher Education Sprout Project, Ministry of Education to the Headquarters of University Advancement at National Cheng Kung University (NCKU).

**ABSTRACT** The generalized recursive circulant networking can be widely used in the design and implementation of interconnection networks. It consists of a series of processors, each is connected through bidirectional, point-to-point communication channels to different neighbors. In this work, we apply the shortest path routing concept to build independent spanning trees on the generalized recursive circulant graphs. The proposed strategy loosen the restricted conditions in previous research and extended the result to a more general vertex setting by design the specific algorithm to deal with the constraint issue.

**INDEX TERMS** Independent spanning trees, generalized recursive circulant graphs, interconnection networks.

## I. INTRODUCTION

Interconnection networks are used to be modeled by an undirected graph where a vertex represents a processor and an edge represents a communication channel. The spanning tree under a topology includes every vertex and connects without loops, massive applications [1]–[5] applied spanning tree structure to build efficient algorithms and solve related research problems. A set of spanning trees are said to be independent if they are rooted at the same root and for each of the remaining vertices there exists internally disjoint paths connect to the root. Considering an asynchronous system communicates by sending messages and data through an unreliable topology. The computation may not be able to conduct in a single processor due to the capacity issue and the distributed resources. To design reliable broadcasting, many researches [6], [7] construct independent spanning trees and restrict all message transmission through these structures. The results reveal that the communication complexity can be more efficient and improving the fault-tolerant ability. Secure information distribution protocols are desirable properties in data communication networks. Several researches [8], [9] have exploited the existence of disjoint structures to achieve efficient, reliable, and secure intentions. Sending different messages safely from the distributor to different destinations, an efficient algorithm to construct independent spanning

trees can be applied to design a distribution protocol with high-level security requirements.

Circulant graphs [10]–[15] have a vast number of applications in communication routing [16], VLSI building [17], and distributed protocols [18]. Tang *et al.* [19] first proposed a superclass of recursive circulant graphs, generalized recursive circulant graphs (GRC graphs), which achieve more flexibility in the cardinality of the vertex set and construct by the circulant graph properties recursively. They investigate several properties of GRC graphs, such as proposed the shortest path routing algorithm and presented the diameter. In this paper, we proposed an efficient algorithm to construct independent spanning trees on GRC graphs. Previous research [20] proposed a method to construct independent spanning trees (ISTs) on a recursive circulant graph by the concept of shortest path routing. But the graph topology restricted under the base be greater than 2. Later, they [21] proposed a set of different rules to deal with the condition that every bases equal 2. In this work, we apply the shortest path routing concept and considering a more flexible setting that can conduct independent spanning trees on the GRC graphs but losing the restricted conditions on the base.

The rest of this paper is organized as follows: the properties and notations of GRC graphs are introduced in Section 2. In Section 3, we present the proposed algorithm to construct independent spanning trees on GRC graphs. And Section 4 proves the correctness of our strategy and the

The associate editor coordinating the review of this manuscript and approving it for publication was Xueqin Jiang.

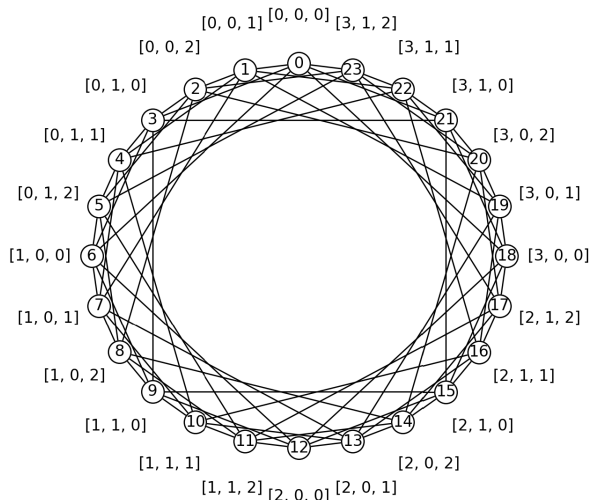

FIGURE 1. General Recursive Circulant Graph:  $GR(4, 2, 3)$ .

experimental results on several complex GRC graph settings. The last section contains concluding remarks and future works.

## II. PRELIMINARIES

GRC graphs are proposed by [19] with the recursive property as recursive circulant graphs, but a more general connection between vertices, which achieve more flexibility in the cardinality of the vertex set. GRC graphs are represented in a mixed radix number system,  $GR(b_h, b_{h-1}, \dots, b_0)$ , where  $b_i \leq 2$  for  $0 \leq i \leq h$ . Index  $i$  is the position of this system and  $b_i$  refers to the base number (or radix) of corresponding position. For each vertex  $x$  labeled with  $(x_h, x_{h-1}, \dots, x_0)$ , where  $0 \leq x_i < b_i$ , presenting the label form of vertex  $x$ . Each vertex is linked to those vertices with only difference in one position by  $\pm 1$  of the mixed radix system. For instance, vertex  $(1, 1, 2)$  in  $GR(4, 2, 3)$  is adjacent to vertices  $(1, 1, 1)$ ,  $(1, 1, 3)$ ,  $(1, 0, 2)$ ,  $(1, 2, 2)$ ,  $(0, 1, 2)$  and  $(2, 1, 2)$ . Note that carry and borrow mechanism in radix system are still implement. For instance, vertex  $(1, 1, 2)$  in  $GR(4, 2, 3)$  is adjacent to vertex  $(1, 2, 2)$  by  $+1$  in position 1. Since  $x_1 = 2$  meets  $b_1 = 2$ , a carry should be added to the next position and  $x_1$  should be reset to 0 at the same time. Therefore, the equivalence of  $(1, 2, 2)$  and  $(2, 0, 2)$  leads to the connection between vertices  $(1, 1, 2)$  and  $(2, 0, 2)$ . As the structure of circulant graphs, the leftmost position will carry to the rightmost position and conduct the circulant property. Figure 1 shows the  $GR(4, 2, 3)$ .

Next, we elaborate the properties of GRC graphs and define the notations will be used in the proposed algorithms.

*Property 1:* GRC graphs are regular and vertex-symmetric.

*Property 2:* Given a GRC graph  $GR(b_h, b_{h-1}, \dots, b_1, b_0)$ .

The degree  $\delta_h$  of each vertex depends on the parameter  $h$  and the leftmost base  $b_h$ :

$$\delta_h = \begin{cases} 2h + 2, & \text{if } b_h > 2; \\ 2h + 1, & \text{if } b_h = 2. \end{cases}$$

*Definition 1:* Since of vertex-symmetric property of GRC graphs, without loss of generality, we choose the vertex  $r = (0, 0, \dots, 0, 0)$ , where  $x_i = 0, 0 \leq i \leq h$ , to be the root vertex for each IST we built.

The connectivity of GRC graphs is  $\delta_h$  for  $h > 2$ , we suggest that there exists  $\delta_h$  ISTs according to the conjecture that the maximum number of ISTs is equal to the connectivity by previous study [22]. To specify which IST we are referring to thereafter, we give the definitions below:

*Definition 2:* We use  $i^+$  (respectively,  $i^-$ ) to represent a movement in the position  $i$  from vertex  $(x_h, \dots, x_i, \dots, x_0)$  to vertex  $(x_h, \dots, x_i + 1, \dots, x_0)$ . (respectively,  $(x_h, \dots, x_i - 1, \dots, x_0)$ )

*Definition 3:* We denote the  $\delta_h$  ISTs we built as  $T_i^{+, -}$ . If the last movement that reach to the root is  $i^+$ , we denote the IST as  $T_i^+$ . On the other hand, if the last movement is  $i^-$ , we denote the IST as  $T_i^-$ .

*Example 1:* In  $GR(4, 2, 3)$ , the parameter  $h = 2$ , so there are  $\delta_h = 6$  ISTs in total. We denote as  $T_0^+, T_1^+, T_2^+, T_0^-, T_1^-, T_2^-$ .

*Definition 4:* We denote the parameter  $N$  as the cardinality of vertices in  $GR(b_h, b_{h-1}, \dots, b_1, b_0)$

$$N = \prod_{i=0}^h b_i$$

*Definition 5:* Given a sequence of movements, we take a set  $M = \{m_0, \dots, m_{|M|-1}\}$  to eliminate the identical movements. This set will present in ascending order according to the number of positions, we define the relation  $succ(M, m_i) = m_{i+1}$  for  $0 \leq i < |M| - 1$  and  $succ(M, m_{|M|-1}) = m_0$ .

## III. CONSTRUCTING INDEPENDENT SPANNING TREES ON GRC GRAPHS

The overview of our proposed strategy to building independent spanning trees on a GRC graph is shown in Figure 2. According to the label form of each vertex, the proposed strategy will find the parent vertex in the specific spanning tree structure to reach the root vertex  $r$ . Our approach can be divided into three parts: the *SHORTEST-PATH* algorithm, *AUGMENTED-PATH* algorithm, and *FIND-PARENTS* algorithm. The *FIND-PARENTS* algorithm will return a *ParentTable*, that can be used to construct  $\delta_h$  ISTs.

---

### Algorithm 1: Main( $GR$ )

---

**Input :**  $GR(b_h, b_{h-1}, \dots, b_0)$ , a GRC graph  
**Output:** *ParentTable*

```

1  $i := 1$ 
2 while  $i < N$  do
3    $SP, D := \text{Find\_shortest\_path}(GR, v_i)$ 
4    $APs := \text{Find\_augmented\_path}(SP, D, v_i)$ 
5    $\text{ParentTable}[v] := \text{Find\_parents}(SP, APs)$ 
6    $i := i + 1$ 
7 return ParentTable

```

---

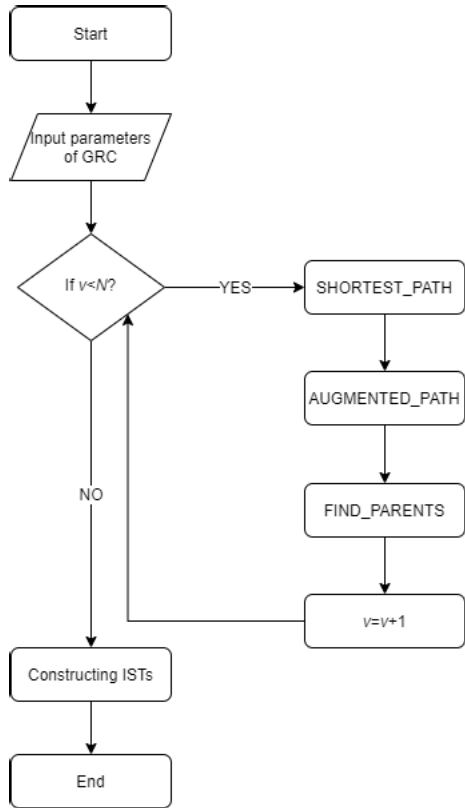

FIGURE 2. Workflow for constructing ISTs of GRC graphs.

**A. SHORTEST-PATH ALGORITHM**

As mentioned in applications for building ISTs on interconnection networks, the major challenge tends toward reducing the heights of trees for better communication performance. Therefore, applying the shortest path concept proposed by previous research [20] to construct ISTs on recursive circulant graphs. We follow the idea of a path-decomposition Latin square and according to the label form of each vertex to construct the shortest path to the root for distinct ISTs. A vertex takes a movement to its neighbor vertex in GRC graphs, the path decomposition means that a path can be expressed as a sequence of movements from the starting vertex. The length of a path is the number of movements it took, and the shortest path from a vertex to the root means it took the minimum movements.

For each base of a GRC graph, we consider the label form of  $v$  and make movements according to the distance between  $v$  and  $r$ . If the digit of position is bigger than half of the base we considering, the movement toward the base will be closer than it toward the 0. Therefore, we take movement  $i^+$  in the shortest path, and vice versa. For instance, the vertex  $v = (1, 1, 2)$  in  $GR(4, 2, 3)$  will take the movement  $0^+$  for the rightmost position, since the digit of position is bigger than half of the base  $x_0 = 2 > b_0/2 = 1.5$ . In this example, one of the shortest paths will be  $(1, 1, 2) \xrightarrow{0^+} (2, 0, 0) \xrightarrow{2^-} (1, 0, 0) \xrightarrow{2^-} (0, 0, 0)$  and the corresponding movements are

$(0^+, 2^-, 2^-)$ . We can rearrange the order of movements to get the other shortest paths.

However, the shortest path concept proposed by previous research [20] could not be dealing with the situation for the base equals 2. When the base equals 2 in position  $i$ , the movements  $i^+$  and  $i^-$  will conduct the identical results and this base-2 issue leading to conflicts when constructing ISTs. Therefore, previous research only constructed ISTs under restricted conditions that the base of the recursive graph needs

**Algorithm 2: Shortest-Path( $GR, v$ )**

---

**Input** :  $GR(b_h, b_{h-1}, \dots, b_0)$ , a GRC graph  
 $v = (x_h, \dots, x_0)$ , given vertex in label form

**Output**:  $SP$ , a set of shortest path movements.  
 $D$ , a list of directions for each position.

```

1   $SP := \emptyset; D := []; i := 0; carry := false$ 
2  while  $i \leq h$  do
3    if  $carry$  is true then
4       $x_i := x_i + 1$ 
5       $carry := false$ 
6    if  $x_i = 0$  then
7       $D.Append('empty')$ 
8    else if  $x_i = b_i$  then
9       $D.Append('full')$ 
10      $carry := true$ 
11   else if  $i = h$  then
12     if  $b_h \geq 2x_h$  then
13        $SP \cup \{i^-\}$ 
14        $D.Append('down')$ 
15     else
16        $SP \cup \{i^+\}$ 
17        $D.Append('up')$ 
18   else if  $b_i \geq 2x_i + 1$  then
19      $SP \cup \{i^-\}$ 
20      $D.Append('down')$ 
21   else if  $b_i = 2x_i$  and  $b_{i+1}$  is even and  $b_{i+1} > 2x_{i+1}$  then
22      $SP \cup \{i^-\}$ 
23      $D.Append('down')$ 
24   else
25      $k := Find\_pivot(i, v, GR)$ 
26     if  $k \neq null$  and  $b_k \geq 2x_k + 2$  then
27        $SP \cup \{i^-\}$ 
28        $D.Append('down')$ 
29     else
30        $SP \cup \{i^+\}$ 
31        $D.Append('up')$ 
32        $carry := true$ 
33    $i := i + 1$ 
34 return  $SP, D$ 
  
```

---

**Algorithm 3:** Find\_pivot( $i, v, GR$ )

---

```

1  $k := i$ 
2 if  $x_k = b_k/2$  then
3    $k := k + 1$ 
4   while  $k < h$  do
5     if  $2x_k + 1 = b_k$  then
6        $k := k + 1$ 
7     else
8       return  $k$ 
9   return  $h$ 
10 else
11   return null

```

---

to be greater than 2. In this work, we extend to the generalized recursive circulant graphs and loss this restricted condition. In the next section, we propose the *AUGMENTED-PATH* algorithm to find the nearly shortest path for each vertex to connect to the root that would deal with the situation that base equals 2 on GRC graphs. But before we discuss further, we need to introduce a new concept named “directions” for the *SHORTEST-PATH* algorithm. There are four directions {‘up’, ‘down’, ‘full’, ‘empty’} for each position based on the *SHORTEST-PATH* algorithm.

- ‘up’
  - This position’s digit is counting upward to the base, and produces a carry to the next position.
- ‘down’
  - This position’s digit is counting downward to ‘0’.
- ‘full’
  - This position’s digit meets the base after adding carry from former position, then also produces a carry to the next position.
- ‘empty’
  - This position’s digit is ‘0’.

According to the label form of vertex  $v$ , the modified *SHORTEST-PATH* outputs a set  $SP$  conduct from a sequence of movements through this shortest path. We also record a list of directions  $D$  for each position which will be used to construct ISTs for the rest part of our strategy. For instance, the vertex  $v = (1, 1, 2)$  in  $GR(4, 2, 3)$ , this algorithm outputs  $SP = \{0^+, 2^-\}$  and  $D = [\text{‘down’}, \text{‘full’}, \text{‘up’}]$  for each corresponding position.

**B. AUGMENTED-PATH ALGORITHM**

We propose the *AUGMENTED-PATH* algorithm to find a nearly shortest path for each vertex to connect to the root that would deal with the situation that base equals 2 on GRC graphs. We conduct several patterns to construct augmented path  $AP$ , which is similar to  $SP$  but the premise is that  $AP$  will not take the same movement in  $SP$ .

**Algorithm 4:** Augmented-Path( $SP, D, v$ )

---

```

Input :  $SP$ , a set of shortest path movements.
          $D$ , a list of directions for each position.
          $v = (x_h, \dots, x_0)$ , given vertex in label form
Output:  $APs$ , augmented paths we constructed.
1  $APs, AP := \emptyset, \emptyset$ 
2  $i, carry := 0, false$ 
3 while  $i < h$  do
4   if  $carry$  is true then  $carry := false, x_i := x_i + 1$ 
5   if  $x_i = b_i$  then  $carry := true$ 
6   else
7     if  $AP.isEmpty()$  then
8       // meets half property
9       if  $x_i = b_i/2$  then
10        if  $i^- \in SP$  then
11           $AP.Append(i^+)$ 
12           $carry := true$ 
13        else if  $i^+ \in SP$  then
14           $AP.Append(i^-)$ 
15        else if  $D[i]$  is ‘up’ then
16           $carry := true$ 
17      else
18        // pattern matching
19        if  $b_i = 2$  and  $b_{i+1} = 2$  then
20          Let  $p$  be  $x_{i+1}(D[i+1])x_i(D[i])$ 
21        else if  $b_i = 2$  and  $b_{i+1} \neq 2$  then
22          Let  $p$  be  $x_{i+1}(D[i+1])x_i(D[i])$ 
23           $APs, AP, carry :=$ 
24            pattern_match_second( $p$ )
25        else if  $b_i \neq 2$  then
26          Let  $p$  be  $x_i(D[i])$ 
27           $APs, AP, carry :=$ 
28            pattern_match_third( $p$ )
27    $i := i + 1$ 
28 return  $APs$ 

```

---

From the shortest path concept, we observe a “half-property” for GRC graphs. When the digit of the position is exactly half of the base ( $x_i = v_i/2$ ), the distance toward the base is equal to the distance toward the 0. Therefore, in that position, we took an opposite direction to conduct an augmenting path with the same distance to reach the 0. In the *AUGMENTED-PATH* algorithm, we make an opposite movement when the position satisfying the half-property. Leading the augmented path to take distinct movements with  $SP$ . Note that this algorithm will match the appropriate pattern according to the digit and direction of each position, and the digit will change by the *carry* from the previous movement.

When designing the *AUGMENTED-PATH* algorithm, we apply the symmetric property of GRC graphs to construct

**Algorithm 5:** pattern\_match\_first( $p$ )

---

```

Input :  $p$ , the pattern  $x_{i+1}(D[i+1])x_i(D[i])$ 
Output:  $APs, AP, carry$ 
1 begin
2   if  $p$  is 1(up)1(empty) then
3     /* case 1: counting up to connect
4       to  $SP$  with the same length */
5      $APs, AP := AppendClear(APs, AP, i, +)$ 
6   else if  $p$  is 0(down)1(full) then
7     /* case 1': counting down to
8       connect to  $SP$  with the same
9       length */
10     $APs, AP := AppendClear(APs, AP, i, -)$ 
11     $carry := true$ 
12  else if  $p$  is 1(full)1(full) then
13    /* case 2: counting up to connect
14      to  $SP/AP$  with length+1, then
15      meet another half property */
16     $APs, AP := AppendClear(APs, AP, i, +)$ 
17     $AP.Append(i^-)$ 
18  else if  $p$  is 0(empty)1(empty) then
19    /* case 2': counting down to
20      connect to  $SP/AP$  with
21      length+1, then meet another
22      half property */
23     $APs, AP := AppendClear(APs, AP, i, -)$ 
24     $AP.Append(i^+)$ 
25     $carry := true$ 
26  else if  $p$  is 1(down)1(empty) then
27    /* case 3: counting up and not
28      connect to  $SP$  */
29     $AP.Append(i^+)$ 
30     $carry := true$ 
31  else if  $p$  is 0(up)1(full) then
32    /* case 3': counting down and not
33      connect to  $SP$  */
34     $AP.Append(i^-)$ 
35  return  $APs, AP, carry$ 

```

---

the augmented paths. The symmetric property will lead to a mirror case for each pattern, that is the directions are corresponding from *up* to *down* (vice versa) and from *empty* to *full* (vice versa). Illustrating the algorithm, we find the first position that satisfies the half property and the base of the next two positions both equals 2. Assuming the position that satisfies the half property took  $i^-$  movement in  $SP$ . Then according to the half property, the augmented path will take the opposite movement  $i^+$  and conduct a *carry* for the next position. When the next two positions of vertex  $v$  match the pattern 1(*up*)1(*empty*), which is case 1 in this algorithm. Since the base of these two positions both equals 2, the augmented

path will take an upward movement (+) and conduct the same result as the *SHORTEST-PATH* algorithm with the same length. There will be a mirror case assuming the position that satisfies the half property took  $i^+$  movement in  $SP$ . Then according to the half property, the augmented path will take the opposite movement  $i^-$ . When the next two positions of vertex  $v$  match the pattern 0(*down*)1(*full*), which is case 1' in this algorithm. Since the base of these two positions both equals 2, the augmented path will take a downward movement (-) and conduct the same result as the *SHORTEST-PATH* algorithm with the same length.

In the *AUGMENTED-PATH* algorithm, we divide each position of the GRC graphs into two groups according to the base value. When the base value equals 2, we assign this position into the “2-factor group.” And besides those positions, we also assign one left more position into the “2-factor group.” The rest of the positions will be assigned to the “N-factor group.” For instance,  $GR(4, 8, 6, 2, 2, 2, 5)$ , the 2-factor group will be  $\{1, 2, 3, 4\}$  ( $b_1 = 2, b_2 = 2, b_3 = 2, b_4 = 6$ ) and the N-factor group will be  $\{0, 5, 6\}$  ( $b_0 = 5, b_5 = 8, b_6 = 4$ ). According to the half property and the movements in  $SP$ , the *AUGMENTED-PATH* algorithm constructs augmented paths to connect to the root with the nearly shortest path. We divided the bases of the GRC graph into two groups and concluded several patterns and their mirror case to construct those paths. Each augmented path will take distinct movement based on the digit and direction in the corresponding positions. For instance, the vertex  $v = (0, 1, 1, 0, 1)$  in  $GR(8, 2, 2, 2, 2)$  will conduct  $SP = \{0^-, 2^+, 4^-\}$  and  $D = ['down', 'full', 'up', 'empty', 'down']$ . At position 0, which satisfies the half property. The *SHORTEST-PATH* algorithm took the movement  $0^-$ . Therefore, the *AUGMENTED-PATH* algorithm takes the opposite movement  $0^+$  and connects to vertex  $v' = (0, 1, 1, 1, 0)$  by adding *carry* from previous position. The next two positions match the pattern for case 1 and taking the movement  $1^+$ . The  $AP = \{0^+, 1^+\}$  and we keep checking the next position for another augmented path. At position 2, which also satisfies the half property. The *SHORTEST-PATH* algorithm took the movement  $2^+$ . Therefore, the *AUGMENTED-PATH* algorithm takes the opposite movement  $2^-$  and connects to vertex  $v'' = (0, 1, 0, 0, 0)$ . The next two positions match the pattern for case 1' and taking the movement  $3^-$ . In this instance the  $APs = \{\{0^+, 1^+\}, \{2^-, 3^-\}\}$ .

**C. FIND-PARENTS**

The *FIND-PARENT* algorithm conducts the  $\delta_h$  distinct parents for each vertex and returns the results to form the *ParentTable* for constructing the  $\delta_h$  ISTs. The previous two algorithms conduct the movement set  $SP$  and  $APs$  for each vertex in the GRC graphs. In this section, we apply the subroutine *CLASSIFIER* to find four variation paths according to the previous movement results. The variations  $SP^*$  and  $AP^*$  will be the extension of the previous movement results; the variation  $\overline{SP}$  takes the opposite movement in the “N-factor” position; and the last variation



**Algorithm 6:** pattern\_match\_second(p)

---

```

Input : p, the pattern  $x_{i+1}(D[i+1])x_i(D[i])$ 
Output: APs, AP, carry
1 begin
2   // X:an arbitrary digit
3   else if p is X(up)1(empty) then
4     /* case 4:similar to case 1 */
5     APs, AP := AppendClear(APs, AP, i, +)
6   if p is X(down)1(full) then
7     /* case 4':similar to case 1' */
8     APs, AP := AppendClear(APs, AP, i, -)
9   else if p is X(full)1(full) then
10    /* case 5:similar to case 2 */
11    APs, AP := AppendClear(APs, AP, i, +)
12    AP.Append(i-)
13  else if p is 0(empty)1(empty) then
14    /* case 5':similar to case 2' */
15    APs, AP := AppendClear(APs, AP, i, -)
16    AP.Append(i+)
17  else if p is X(down)1(empty) then
18    /* case 6:counting down and
19     connect to SP, then meet
20     another half property */
21    APs, AP := AppendClear(APs, AP, i, -)
22    AP.Append(i+)
23  else if p is X(up)1(full) then
24    /* case 6':counting up and
25     connect to SP, then meet
26     another half property */
27    APs, AP := AppendClear(APs, AP, i, +)
28    AP.Append(i-)
29  return APs, AP, carry

```

---

others conduct movements that belong to this GRC graph but not have been used in the previous situations. Here, we use the notation  $\oplus$  to represent that the vertex  $v$  takes the movement  $m$  and the opposite of movement  $m$  can be denoted as  $-m$ . For instance, the vertex  $v = (0, 1, 1, 0, 1)$  in  $GR(8, 2, 2, 2, 2)$  will conduct  $SP = \{0^-, 2^+, 4^-\}$  and  $APs = \{\{0^+, 1^+\}, \{2^-, 3^-\}\}$ . The *parents\_for\_ISTs* =  $[(1, 0, 0, 0, 1), (0, 1, 0, 1, 1), (0, 0, 1, 0, 1), (0, 1, 0, 0, 1), (0, 1, 1, 0, 0), (1, 1, 1, 0, 1), (1, 0, 1, 0, 1), (7, 1, 1, 0, 1), (0, 1, 1, 1, 0), (0, 1, 1, 1, 1)]$ . The index of *parents\_for\_IST* from 0 to  $\delta_h - 1$  are referring to IST and list below in order.  $T_0^-, T_1^-, T_2^-, T_3^-, T_4^-, T_4^+, T_3^+, T_2^+, T_1^+, T_0^+$ .

**IV. CORRECTNESS**

*Lemma 1:* Each subgraph we constructed is a spanning tree on the GRC graph.

**Algorithm 7:** pattern\_match\_third(p)

---

```

Input : p, the pattern  $x_i(D[i])$ 
Output: APs, AP, carry
1 begin
2   if p is 1(empty) then
3     /* case 7:counting down to
4     connect to SP/AP with
5     lenght+1 */
6     APs, AP := AppendClear(APs, AP, i, -)
7   else if p is X(full) and  $X = b_i - 1$  then
8     /* case 7':counting up to
9     connect to SP/AP with
10    lenght+1 */
11    APs, AP, carry := AppendClear(APs, AP, i, +);
12    carry := true
13  else if p is X(down) then
14    if AP.Length() = 1 then
15      AP.Append(i+)
16      if  $X < \lfloor b_i/2 \rfloor$  then
17        APs.Append(AP); AP.Clear()
18      else if  $X = \lfloor b_i/2 \rfloor$  then
19        carry := true
20    else if AP.Length() > 1 then
21      APs.Append(AP); AP.Clear()
22  else if p is X(up) then
23    if AP.Length() = 1 then
24      APs, AP, carry :=
25      AppendClear(APs, AP, i, -)
26      carry := true
27    else if AP.Length() > 1 then
28      APs.Append(AP)
29      AP.Clear(); carry := true
30  if  $i \in N - \text{factor}$  then
31    if  $x_i = b_i/2$  then
32      APs, AP, carry :=
33      AppendClear(APs, AP, i, -)
34      carry := true
35    else if p is 1(empty) then
36      APs, AP, carry :=
37      AppendClear(APs, AP, i, -)
38    else if p is  $N - 1$ (full) then
39      APs, AP, carry :=
40      AppendClear(APs, AP, i, +)
41      carry := true
42    else
43      AP.Clear()
44  return APs, AP, carry

```

---

**Algorithm 8:** AppendClear( $APs, AP, i, s$ )

---

**Input** :  $APs, AP$   
 $i$ , the position.  
 $s \in \{+, -\}$ , denote counting up/down.

**output:**  $APs, AP$

1 **begin**  
2    $AP.Append(i^s)$   
3    $APs.Append(AP)$   
4    $AP.Clear()$   
5   **return**  $APs, AP$

---

**Algorithm 9:** Find\_parents( $SP, APs$ )

---

**Input** :  $SP, APs$   
**Output:**  $parents\_for\_ISTs$

1  $parents\_for\_ISTs := []$   
2  $SP^*, AP^*, \overline{SP}, others, dict := \text{Classifier}(SP, APs, \delta_h)$   
3 **while**  $i < \delta_h$  **do**  
4    $m := dict[i]$   
5   **if**  $m$  is a movement exists in  $AP$  **then**  
6      $parents\_for\_ISTs[i] := v \oplus succ(AP, m)$   
7   **else if**  $m \in SP$  **then**  
8      $parents\_for\_ISTs[i] := v \oplus succ(SP, m)$   
9   **else if**  $m \in \overline{SP} \cup SP^* \cup AP^*$  **then**  
10     $parents\_for\_ISTs[i] := v \oplus m$   
11   **else**  
12     $parents\_for\_ISTs[i] := v \oplus m$   
13     $i := i + 1$   
14 **return**  $parents\_for\_ISTs$

---

*Proof:* First, we find a parent vertex for each vertex in distinct  $\delta_h$  subgraphs we constructed. Since this algorithm iterates each vertex in the GRC graphs once. It guarantees the  $\delta_h$  spanning subgraphs on the GRC graph. Then, we prove that this spanning subgraph is a tree structure. There is only one path in each subgraph we constructed that connects this vertex to the root. Considering the following cases, we denote  $T_m$  as the IST that the last movement connects to the root is  $m$ :

Case 1: Suppose  $SP = \{m_0, m_1, \dots, m_{t-1}\}$  and  $m_i \in SP$ , we have its decomposition with  $(m_{i+1}, m_{i+2}, \dots, m_i)$  for  $T_{m_i}$ . By *FIND-PARENT*, we can get the vertex's parent  $v_{p1}$  after taking  $m_{i+1}$  and the length of decomposition will minus one. As for vertex  $v_{p1}$ , its decomposition become  $(m_{i+2}, \dots, m_i)$ . In the end, with the same operation, the vertex can be routed to the child vertex of root with decomposition  $(m_i)$  then connect to root after taking the movement.

Case 2: Suppose  $SP = \{m_0, m_1, \dots, m_{t-1}\}$  and  $m_i \in others$ . The vertex will take  $-m_i$  as the first movement to its parent  $v_{p1}$  in  $T_{m_i}$  by *FIND-PARENT*. Then  $v_{p1}$ 's  $SP$  must contain  $m_i$  and its decomposi-

**Algorithm 10:** Classifier( $SP, APs, \delta_h$ )

---

**Input** :  $SP, APs, \delta_h$   
**Output:**  $SP^*, AP^*, \overline{SP}, others, dict$

1  $i := 0$   
2  $sign := null$   
3  $dict := null$   
4 **while**  $i < \delta_h$  **do**  
5   **if**  $2 * i \leq \delta_h - 1$  **then**  
6      $sign := -$   
7      $u := i$   
8   **else**  
9      $sign := +$   
10     $u := \delta_h - 1 - i$   
11    $m := u^{sign}$   
12    $dict[i] := m$   
13   **if**  $m \notin (AP \cup SP)$  **then**  
14     **if**  $u \in 2 - factor$  **and**  $(u + 1)^{(+,-)} \in SP$  **then**  
15       $SP^*.Append(m)$   
16     **else if**  $u \in 2 - factor$  **and**  $(u + 1)^{(+,-)} \in AP$  **then**  
17       $AP^*.Append(m)$   
18     **else if**  $u \in N - factor$  **and**  $-m \in SP$  **then**  
19       $\overline{SP}.Append(m)$   
20     **else**  
21       $others.Append(-m)$   
22     $i := i + 1$   
23 **return**  $SP^*, AP^*, \overline{SP}, others, dict$

---

tion is  $(m_{i+1}, \dots, m_i)$ . By taking the movements in order like Case 1, the vertex will be routed to the child vertex of root with decomposition  $(m_i)$  then connect to root after taking the movement.

Case 3: Suppose  $SP = \{m_0, m_1, \dots, m_{t-1}\}$  and  $m_i \in \overline{SP}$ , that is,  $-m_i \in SP$ . By *FIND-PARENTS*, the vertex will take  $m_i$  at first to its parent  $v_{p1}$  in  $T_{m_i}$ . If  $m_i$  still  $\notin SP$  of  $v_{p1}$ , the vertex will keep taking the movement  $m_i$  until to the ancestor whose  $SP$  contain  $m_i$ . Then like Case 1, the decomposition becomes  $(\dots, m_i)$  with  $m_i$  be the last movement. In the end, the vertex will be route to the child vertex of root with decomposition  $(m_i)$  then connect to root after taking the movement.

Case 4: Suppose  $m_i \in AP, AP = \{\dots, m_i, m_{i+1} \dots\}$ . The vertex will take  $m_{i+1}$  to its parent  $v_{p1}$  in  $T_{m_i}$  by *FIND-PARENT*. At  $v_{p1}$ , either  $m_i \in SP$  or  $m_i \in AP$ . If  $m_i \in SP$ , like Case 1, the decomposition will be  $(\dots, m_i)$ . In the end, the vertex will be routed to the child vertex of root with decomposition  $(m_i)$  then connect to root after taking the movement. If  $m_i \in AP$ , using the same way to its parent  $v_{p2}$  after taking movement by *FIND-PARENT*. Eventually,

TABLE 1. experiment results.

GRC graph	N	$\delta_h$	Height		Run time(ms)
			Max.	Avg.	
GR(4, 2)	8	4	4	2.125	0.4776
GR(4, 2, 2)	16	6	5	2.625	1.2317
GR(4, 2, 2, 2)	32	8	6	3.055	1.4821
GR(4, 2, 2, 2, 2)	64	10	7	3.456	3.4754
GR(4, 2, 2, 2, 2, 2)	128	12	8	3.850	10.3512
GR(4, 2, 2, 2, 2, 2, 2)	256	14	10	4.616	97.9597
GR(3, 3)	9	4	3	2.111	0.607
GR(3, 3, 3)	27	6	4	2.926	2.1377
GR(3, 3, 3, 3)	81	8	5	3.642	7.3423
GR(3, 3, 3, 3, 3)	243	10	6	4.325	24.8076
GR(10, 10)	100	4	14	7.175	2.7766
GR(10, 10, 10)	1000	6	19	9.65	41.4834
GR(10, 10, 10, 10)	10000	8	23	12.108	507.5772
GR(4, 2, 3)	24	6	5	2.917	1.6722
GR(3, 4, 5)	60	6	7	3.867	4.7639
GR(6, 7, 8, 9)	6024	8	17	9.059	160.5518
GR(10, 11, 12, 13)	17160	8	27	13.990	1050.1259
GR(6, 2, 2, 5)	120	8	9	4.65	5.3769
GR(43, 19, 27)	22059	6	64	29.223	1080.1769

TABLE 2. Experimental environment.

	Specific configuration
OS	macOS High Sierra
CPU	Intel Core i5 2.3GHz
RAM	8GB
Programming language	Python 3.7.3

$m_i$  will belong to  $SP$  at one ancestor. In the end, the vertex will be routed to the child vertex of root with decomposition  $(m_i)$  then connect to root after taking the movement.

Case 5: Suppose  $m_i \in SP^*$  and  $m_i$ 's position is  $i$ , Because the movement at position  $i + 1 \in SP$ . If  $D[i + 1] = 'up'$ , by taking  $m_i$  and routed to its parent result in  $x_i$  from 0 to 1, and it will make  $m_i \in SP$ . Otherwise, if  $D[i + 1] = 'down'$ , the vertex also is routed to parent whose  $SP$  contain  $m_i$ . Like Case 1, the decomposition becomes  $(\dots, m_i)$  with  $mv_i$  be the last movement. In the end, the vertex will be routed to the child vertex with decomposition  $(m_i)$  then connect to root after taking the movement.

Case 6: Suppose  $m_i \in AP^*$  and  $m_i$ 's position is  $i$ , Because there's a movement at position  $i + 1 \in AP$ . By taking  $m_i$  and routed to its parent in  $T_{m_i}$ , which result in  $x_i$  from 0 to 1, and it will make  $m_i \in AP$ . Like Case 4, eventually the routed path will reach to the ancestor that contain  $m_i$  in its  $SP$ . In the end, the vertex will be routed to the child vertex of root with decomposition  $(m_i)$  then connect to root after taking the movement.

**Lemma 2:** According to the algorithm we proposed, if there are two paths from one vertex to the root and the first movement of one path would not exist in the movements of the other path, then these two paths are internally disjoint.

**Proof:** Let the decompositions of these two paths be  $P_a = (m_{a1}, m_{a2} \dots m_{at})$  and  $P_b = (m_{b1}, m_{b2} \dots m_{bn})$ . The

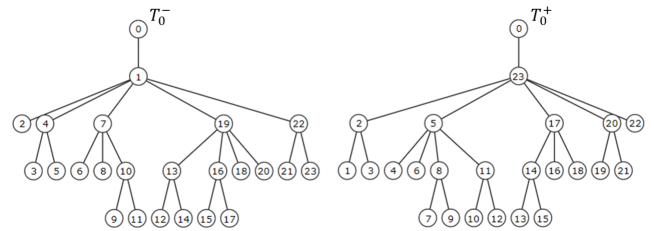

FIGURE 3. ISTs  $T_0^-$  and  $T_0^+$  we constructed on  $GR(4, 2, 3)$ .

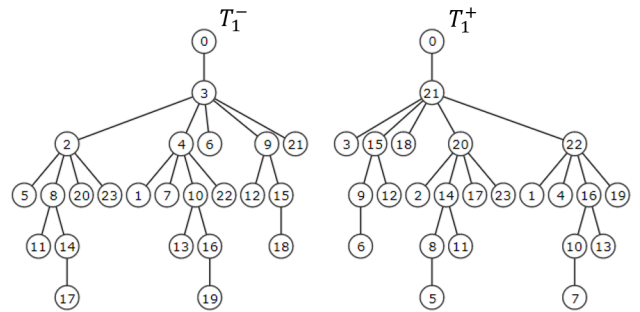

FIGURE 4. ISTs  $T_1^-$  and  $T_1^+$  we constructed on  $GR(4, 2, 3)$ .

vertex set  $Z_a$  and  $Z_b$  denote the vertices that each path passed. These two paths starting from the same vertex to root are internally disjoint if and only if the vertices they passed can't be equivalent. That is,  $\forall x \in Z_a, \forall y \in Z_b, x \neq y$ . Due to  $m_{a1}$  as the first movement in  $P_a$ , we know that  $v$  must took  $m_{a1}$  to  $x$ . However, since  $m_{a1} \notin P_b$ , if the combination of  $m_{a1}$  with other movements in  $P_a$  could not equivalent to movements in  $P_b$ , then  $x \neq y$ . If the combination of  $m_{a1}$  with other movements in  $P_a$  could equivalent to movements in  $P_b$ , because there must be one movement in the combination as the last movement in  $P_a$ , from definition of  $Z_a$ , combination can't be met, so  $x \neq y$ . ■

**Theorem 1:** According to the algorithm we proposed, we construct  $\delta_h$  independent spanning trees on the generalized recursive circulant graphs.

**Proof:** Given a vertex, from Lemma 1 we can construct each path to root for all spanning trees. And by Lemma 2, it can prove all these paths are pairwise internally disjoint. Therefore, the  $\delta_h$  spanning trees we constructed are independent to each other. ■

In the *SHORTEST-PATH* algorithm, it takes  $O(h)$  time by iterating every position in GRC. And in the *AUGMENTED-PATH* algorithm, it also takes  $O(h)$  to construct all augmented path for the same reason. In the *FIND-PARENT* algorithm, it decides parents through every  $i$ , where  $0 \leq i < \delta_h$ . In addition,  $\delta_h$  is actually  $O(h)$ . Therefore, it takes  $O(h)$  time in the *FIND-PARENT* algorithm. Lastly, since all vertices have to do all the procedures above. The aggregate of time in this strategy to construct  $\delta_h$  ISTs in a GRC graph takes  $O(Nh)$ .

We also discuss the experimental results that implementing the proposed strategy to construct  $\delta_h$  ISTs on the various GRC graphs. Table 1 reveals that the cardinality of the GRC graphs we experimenting with from the simplest 8 vertices to



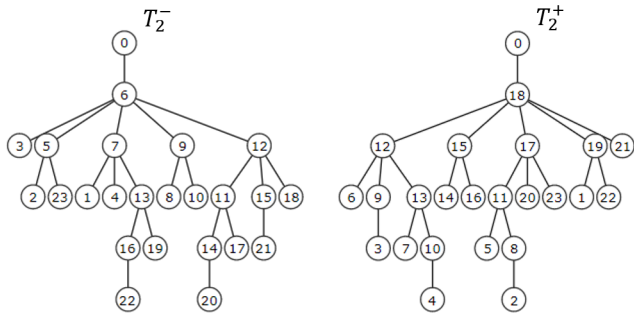

FIGURE 5. ISTs  $T_2^-$  and  $T_2^+$  we constructed on  $GR(4, 2, 3)$ .

22,059 vertices. The running time of each experiment took under one second, the experiment environment is showing in Table 2, and most simple GRC graphs took less than one nanosecond to construct  $\delta_h$  ISTs. Note that  $\delta_h$  is the maximum number of ISTs that a GRC graph can construct. And in Table 1, we count the height information of each ISTs and remark the average height and the maximal height we built. As mention before, in applications for building ISTs on interconnection networks, the major challenge tends toward reducing the heights of trees for better communication performance. The experiment results reveal that the average heights of ISTs we constructed on complex GRC graphs (the cardinality of the vertex set is higher than 10,000 vertices) is less than 30 levels. Figure 3, Figure 4, and Figure 5 are the  $\delta_h = 6$  ISTs constructed according to our proposed algorithm on  $GR(4, 2, 3)$ . Since in  $GR(4, 2, 3)$ , the cardinality of the vertex set is 24, we label each vertex from 0 to 23.

V. CONCLUSION

In this work, we apply the shortest path routing concept to build independent spanning trees on the generalized recursive circulant graphs. The proposed strategy loosen the restricted conditions in previous research and extended the result to a more general vertex setting by design a specific algorithm to deal with the constraint issue. The GRC graphs can be widely used in the implementation of interconnection networks, massive applications applied spanning tree structure to build efficient algorithms and solve related applications such as reliable broadcasting and secure distributed protocols. The major challenge tends toward reducing the heights of trees for better communication performance. According to the label form of each vertex, our proposed strategy follows the shortest path routing concept and finds a parent vertex in the specific spanning tree structure to reach the root. We also propose the AUGMENTED-PATH algorithm to find the nearly shortest path for each vertex to connect to the root that would deal with the situation that base equals 2 on GRC graphs.

The aggregate of time in this strategy to construct  $\delta_h$  ISTs in a GRC graph takes  $O(Nh)$  and satisfying the conjecture that the connectivity is equal to the number of vertex-disjoint spanning trees. We discuss the experimental results that implementing the proposed strategy to construct  $\delta_h$  ISTs on the various GRC graphs. The cardinality of the GRC

graphs we experimenting with from the simplest 8 vertices to 22,059 vertices and the running time of each experiment took under one second. The experiment results also reveal that the average heights of ISTs we constructed on complex GRC graphs. When the cardinality of the vertex set is higher than 10,000 vertices, the average height of  $\delta_h$  ISTs is less than 30 levels. We will consider the optimal height of ISTs as our future work, to conduct a more efficient algorithm for the GRC related graph structures.

REFERENCES

- [1] J.-F. Huang, S.-S. Kao, S.-Y. Hsieh, and R. Klasing, "Top-down construction of independent spanning trees in alternating group networks," *IEEE Access*, vol. 8, pp. 112333–112347, 2020.
- [2] C.-F. Lin, J.-F. Huang, and S.-Y. Hsieh, "Constructing independent spanning trees on transposition networks," *IEEE Access*, vol. 8, pp. 147122–147132, 2020.
- [3] D.-W. Cheng, C.-T. Chan, and S.-Y. Hsieh, "Constructing independent spanning trees on pancake networks," *IEEE Access*, vol. 8, pp. 3427–3433, 2020.
- [4] B. Cheng, D. Wang, and J. Fan, "Constructing completely independent spanning trees in crossed cubes," *Discrete Appl. Math.*, vol. 219, pp. 100–109, Mar. 2017.
- [5] S.-S. Kao, K.-J. Pai, S.-Y. Hsieh, R.-Y. Wu, and J.-M. Chang, "Amortized efficiency of constructing multiple independent spanning trees on bubble-sort networks," *J. Combinat. Optim.*, vol. 38, no. 3, pp. 972–986, Oct. 2019.
- [6] A. Itai and M. Rodeh, "The multi-tree approach to reliability in distributed networks," *Inf. Comput.*, vol. 79, no. 1, pp. 43–59, Oct. 1988.
- [7] F. Bao, Y. Funiyu, Y. Hamada, and Y. Igarashi, "Reliable broadcasting and secure distributing in channel networks," *IEICE Trans. Fundam. Electron., Commun. Comput. Sci.*, vol. 81, no. 5, pp. 796–806, 1998.
- [8] A. A. Rescigno, "Vertex-disjoint spanning trees of the star network with applications to fault-tolerance and security," *Inf. Sci.*, vol. 137, nos. 1–4, pp. 259–276, Sep. 2001.
- [9] J.-S. Yang, H.-C. Chan, and J.-M. Chang, "Broadcasting secure messages via optimal independent spanning trees in folded hypercubes," *Discrete Appl. Math.*, vol. 159, no. 12, pp. 1254–1263, Jul. 2011.
- [10] B. Alspach, S. C. Locke, and D. Witte, "The Hamilton spaces of Cayley graphs on abelian groups," *Discrete Math.*, vol. 82, no. 2, pp. 113–126, Jun. 1990.
- [11] F. T. Boesch and A. P. Felzer, "A general class of invulnerable graphs," *Networks*, vol. 2, no. 3, pp. 261–283, 1972.
- [12] F. Boesch and R. Tindell, "Circulants and their connectivities," *J. Graph Theory*, vol. 8, no. 4, pp. 487–499, 1984.
- [13] R. C. Entringer, D. E. Jackson, and D. Snyder, "Distance in graphs," *Czechoslovak Math. J.*, vol. 26, no. 2, pp. 283–296, 1976.
- [14] B. Elspas and J. Turner, "Graphs with circulant adjacency matrices," *J. Combinat. Theory*, vol. 9, no. 3, pp. 297–307, Oct. 1970.
- [15] M. E. Muzychuk, M. H. Klin, and R. Pöschel, "The isomorphism problem for circulant graphs via Schur ring theory," *Codes Assoc. schemes*, vol. 56, pp. 241–264, 1999. [Online]. Available: <https://www.semanticscholar.org/paper/The-isomorphism-problem-for-circulant-graphs-via-Muzychuk-Klin/250f24385880d097c381d3e0e75a85f10cdf62?p2df>
- [16] B. Mans, "Optimal distributed algorithms in unlabeled tori and chordal rings," *J. Parallel Distrib. Comput.*, vol. 46, no. 1, pp. 80–90, Oct. 1997.
- [17] F. T. Leighton, *Introduction to Parallel Algorithms and Architectures: Arrays · Trees · Hypercubes*. Amsterdam, The Netherlands: Elsevier, 2014.
- [18] J. C. Bermond, F. Comellas, and D. F. Hsu, "Distributed loop computer networks: A survey," *J. Parallel Distrib. Comput.*, vol. 24, no. 1, pp. 2–10, Jan. 1995.
- [19] S.-M. Tang, Y.-L. Wang, and C.-Y. Li, "Generalized recursive circulant graphs," *IEEE Trans. Parallel Distrib. Syst.*, vol. 23, no. 1, pp. 87–93, Jan. 2012.
- [20] J.-S. Yang, J.-M. Chang, S.-M. Tang, and Y.-L. Wang, "On the independent spanning trees of recursive circulant graphs  $G(cdm, d)$  with  $d > 2$ ," *Theor. Comput. Sci.*, vol. 410, nos. 21–23, pp. 2001–2010, 2009.

- [21] J. S. Yang, J. M. Chang, S. M. Tang, and Y. L. Wang, "Constructing multiple independent spanning trees on recursive circulant graphs  $G(2^m, 2)$ ," *Int. J. Found. Comput. Sci.*, vol. 21, no. 01, pp. 73–90, 2010.
- [22] A. Zehavi and A. Itai, "Three tree-paths," *J. Graph Theory*, vol. 13, no. 2, pp. 175–188, Jun. 1989.



**DUN-WEI CHENG** received the M.S. degree from the Department of Computer Science and Information Engineering, National University of Kaohsiung, in 2011. He is currently pursuing the Ph.D. degree with the Department of Computer Science and Information Engineering, National Cheng Kung University, Tainan, Taiwan. His current research interests include financial computing, artificial intelligence, system-level fault diagnosis, and hub location problem.



**KAI-HSUN YAO** received the B.S. degree from the Department of Mechanical and Electro-Mechanical Engineering, National Sun Yat-sen University, Kaohsiung, Taiwan, in June 2014. He is currently pursuing the M.S. degree with the Computer Science and Information Engineering Department, National Cheng Kung University, Tainan, Taiwan. His current research interests include design and analysis of algorithms and graph theory.



**SUN-YUAN HSIEH** (Senior Member, IEEE) received the Ph.D. degree in computer science from National Taiwan University, Taipei, Taiwan, in June 1998.

He then served the compulsory two-year military service. From August 2000 to January 2002, he was an Assistant Professor with the Department of Computer Science and Information Engineering, National Chi Nan University. He joined the Department of Computer Science and Information

Engineering, National Cheng Kung University, in February 2002, where he is currently a Chair Professor. His current research interests include design and analysis of algorithms, fault-tolerant computing, bioinformatics, parallel and distributed computing, and algorithmic graph theory.

Dr. Hsieh is a Fellow of the British Computer Society (BCS) and a Fellow of the Institution of Engineering and Technology (IET). He received several awards, including the 2007 K. T. Lee Research Award, the President's Citation Award (American Biographical Institute) in 2007, the Engineering Professor Award of Chinese Institute of Engineers (Kaohsiung Branch) in 2008, the National Science Council's Outstanding Research Award in 2009, the IEEE Outstanding Technical Achievement Award (IEEE Tainan Section) in 2011, the Outstanding Electronic Engineering Professor Award of Chinese Institute of Electrical Engineers in 2013, and the Outstanding Engineering Professor Award of Chinese Institute of Engineers in 2014. He is also an experienced editor with editorial services to a number of journals, including serving as an Associate Editor for IEEE ACCESS, IEEE TRANSACTIONS ON RELIABILITY, *Theoretical Computer Science* (Elsevier), *Discrete Applied Mathematics* (Elsevier), *Journal of Supercomputing* (Springer), *International Journal of Computer Mathematics* (Taylor & Francis Group), *Parallel Processing Letters* (World Scientific), *Discrete Mathematics, Algorithms and Applications* (World Scientific), *Fundamental Informaticae* (Polish Mathematical Society), and *Journal of Interconnection Networks* (World Scientific). He has served on organization committee and/or program committee of several dozens international conferences in computer science and computer engineering.

...