

Received January 22, 2021, accepted April 4, 2021, date of publication April 15, 2021, date of current version May 14, 2021.

Digital Object Identifier 10.1109/ACCESS.2021.3073543

Interference Management in 5G and Beyond Network: Requirements, Challenges and Future Directions

MARAJ UDDIN AHMED SIDDIQUI¹, FAIZAN QAMAR², FAISAL AHMED³,
QUANG NGOC NGUYEN⁴, (Member, IEEE), AND ROSILAH HASSAN², (Senior Member, IEEE)

¹Faculty of Engineering and Information Sciences, School of Electrical, Computer and Telecommunications Engineering, University of Wollongong, Wollongong, NSW 2522, Australia

²Centre for Cyber Security, Faculty of Information Science and Technology, Universiti Kebangsaan Malaysia (UKM), Bangi 43600, Malaysia

³Software Engineering, Faculty of Social Sciences, Narva College, University of Tartu, 20307 Narva, Estonia

⁴Department of Computer Science and Communications Engineering, Faculty of Science and Engineering, Waseda University, Tokyo 169-8050, Japan

Corresponding authors: Quang Ngoc Nguyen (quang.nguyen@fuji.waseda.jp) and Rosilah Hassan (rosilah@ukm.edu.my)

This work was supported in part by the Network Communication Technology (NCT) Research Groups, FTSM, Universiti Kebangsaan Malaysia, in part by the Dana Impak Perdana UKM under Grant DIP-2018-040, in part by the Fundamental Research Grant Scheme under Grant FRGS/1/2018/TK04/UKM/02/17, in part by the Fujitsu-Waseda Digital Annealer FWDA Research Project and Fujitsu Co-Creation Research Laboratory, Waseda University (Joint Research between Waseda University, Japan, and Fujitsu Laboratories), and in part by the School of Fundamental Science and Engineering, Faculty of Science and Engineering, Waseda University.

ABSTRACT In the modern technological world, wireless communication has taken a massive leap from the conventional communication system to a new radio communication network. The novel concept of Fifth Generation (5G) cellular networks brings a combination of a diversified set of devices and machines with great improvement in a unique way compared to previous technologies. To broaden the user's experience, 5G technology provides the opportunity to meet the people's potential necessities for efficient communication. Specifically, researchers have designed a network of small cells with unfamiliar technologies that have never been introduced before. The new network design is an amalgamation of various schemes such as Heterogeneous Network (HetNet), Device-to-Device (D2D) communication, Internet of Things (IoT), Relay Node (RN), Beamforming, Massive Multiple Input Multiple Output (M-MIMO), millimeter-wave (mm-wave), and so on. Also, enhancement in predecessor's techniques is required so that new radio is compatible with a traditional network. However, the disparate technological models' design and concurrent practice have created an unacceptable intervention in each other's signals. These vulnerable interferences have significantly degraded the overall network performance. This review article scrutinizes the issues of interferences observed and studied in different structures and techniques of the 5G and beyond network. The study focuses on the various interference effect in HetNet, RN, D2D, and IoT. Furthermore, as an in-depth literature review, we discuss various types of interferences related to each method by studying the state-of-the-art relevant research in the literature. To provide new insight into interference issue management for the next-generation network, we address and explore various relevant topics in each section that help make the system more robust. Overall, this review article's goal is to guide all the stakeholders, including students, operators, engineers, and researchers, aiming to explore this promising research theme, comprehend interferences and their types, and related techniques to mitigate them. We also state methodologies proposed by the 3rd Generation Partnership Project (3GPP) and present the promising and feasible research directions toward this challenging topic for the realization of 5G and beyond network.

INDEX TERMS Interference, 5G and beyond (B5G), HetNet, relay node, D2D, IoT.

I. INTRODUCTION

In future wireless communication, it is expected that hundreds of different devices and users communicate with each

The associate editor coordinating the review of this manuscript and approving it for publication was Ting Yang.

other simultaneously. The explosive growth in user data demand with a 1000-fold increase in user density triggers the need to explore the broader horizon of the radio link to accommodate future requisites with a more comprehensive approach effectively [1]. An enormous amount of research was conducted and still being performed in various sections

of radio communication. Researchers from all parts of the communication and networking societies, from academia to industrialists and vendors to operators, have actively participated in making this theme possible [2]. This phenomenon leads to enormous growth in higher throughput, larger capacity, and lower latency in the air (up to 1ms) and in a cellular network (end-to-end delay less than 10ms) [3]. Besides, this tendency is predicted to be increased drastically in the next decade. The combination of advancement in predecessor's technologies and innovative work in wireless transmission shows a tendency to fulfill user's requisite and next-generation cellular objectives i.e., 5G and beyond, or sometimes referred to as Sixth- Generation (6G) networks [4]. Typically, the massive expansion in traffic is due to a rise in demand for high-definition applications and services, social networking, gaming, online surfing, concurrent operation of a diverse set of machine type communication, and so on. It is expected to provide high Quality of Services (QoS) requirements of real-time and heavy data applications with secure connections [5].

By virtue of matching extensive cellular data requirements and supporting massive machine type communication and internet services, 5G new radio is supposed to provide expected high efficiency. The 5G is divided into two frequency ranges (FRs), i.e., FR1 < 6 GHz and FR2 > 24 GHz (mm-wave band) [6]. It is observed that FR1 is almost fully occupied and has limited resources to be utilized for the current 5G network, whereas FR2 is the frequency range where most of the spectrum untapped, and it can be easily exploited for future cellular communication [7]. To satisfy the user's requirements of cellular technology, various types of techniques were introduced, such as Massive Multiple Input Multiple Output (M-MIMO) [8], Heterogeneous Network (HetNet) [9], Cognitive Radio (CR) [10], Ad-hoc network [11], and so on. These methods are a joint venture of previous and novel wireless technologies [12].

In the conventional cellular system, it is observed that the available technologies, with the scarcity of the spectrum and high power consumption, do not satisfy the future data demand of the users and environmental standards [13]. Technological enhancement in the traditional single-cell network due to several limitations is impracticable. This phenomenon leads to innovative design and wireless communication techniques that help accomplish user's requirements in the next decade. Therefore, an ultra-dense mobile network is expected to accommodate a vast number of users with maximum throughput, twice the spectral efficiency, and better power consumption compared to the traditional cellular network [14]. According to the wireless network technologies analysis, the next-generation cellular network is expected to deliver each user with ultra-reliable connectivity via multiple devices anywhere and anytime [15]. Thus, to dispense user necessitate and better network performance, the researchers suggest a network's densification by deploying small cell nodes such as micro-, pico-, femto-, and relays. The inter-communication of all small cells within a macro cell is known

as HetNet [16]. It is a network that supports high reliability with greater capacity of the users, less power consumption, minimum end-to-end delay, enhanced spectrum, and energy efficiencies [17].

The next-generation network is considered a multi-tier HetNet cellular network because it supports various wireless devices in each tier [18]. Each tier consists of small gadgets to heavy machine type wireless equipment and sends data request directly to its respective small base station (SBS), which requires low power for transmission and minimized energy consumption [19]. However, in a multi-tier 5G cellular network, the simultaneous operation of many small cells is severely damaged by the different types of interferences that limit the user's quality of experience and reduce the current 5G expectations [20]. The heavy interference issues are due to the novel architecture, the wireless medium's broadcast nature, and complex coordination of low-power small cells. Also, the heterogeneity structure and newer modulation and multiple access techniques introduce unique types of interference. Therefore, the management, mitigation, and cancellation of Interferences play a critical part in the current 5G mobile communication [21].

Furthermore, due to previous mobile generation's limitations, such as congestion in the below 6 GHz frequency band and the need for higher bandwidth, an mm-wave frequency band has been introduced in current 5G networks [22]. It offers a large untapped frequency band that can increase the system capacity by 100 times compared to a conventional homogeneous network, especially the 4G LTE network [23]. It relies highly on directional transmission and minimizes the heavy isotropic path loss. There are also prominent differences in path loss of mm-wave transmission for cellular users in Line-of-Sight (LOS) and Non-Line-of-Sight (NLOS) coverages [24]. However, mm-wave sinusoid size is concise and the small amplitude wavelength does not penetrate over a long distance and is badly affected by the scattering, fading, refraction, propagation losses, and blocked by various concrete-based building structures [25]. It is also positively exposed to the reflection and refraction phenomenon due to heavy glass materials. Besides, the atmospheric absorption characteristics at the extremely high-frequency range (30-300 GHz) and the signal attenuation in heavy rain limit the mm-wave transmission's propagation distance. In particular, in an urban coverage area, users with an mm-wave spectrum in ultra-dense network encounter penetration, reflection, and interference issues. Therefore, it is very critical to conduct proper channel modeling of each mm-wave spectrum before the practical deployment [26]. Moreover, the shorter wavelength and simultaneous operation of small cells within a macro cell induce more troublesome for the cell edge users. The reason is that they are devastated vigorously by the interference of MBS downlink signals and inter-cell interference besides Self-Interference (SI) due to the single antenna duplexer technique [27]. This review helps to provide new insight into interference management for the next-generation network by addressing and exploring various factors and

relevant topics. Each section helps make the system more robust. To the best of the author's knowledge, there is no such work in literature that focuses on the comprehensive study on interference issues for these four main 5G research areas, i.e., HetNet, RN, D2D, and IoT. The topic discussed in this study is about the Interference management in 5G and beyond network, as summarized in Fig. 1.

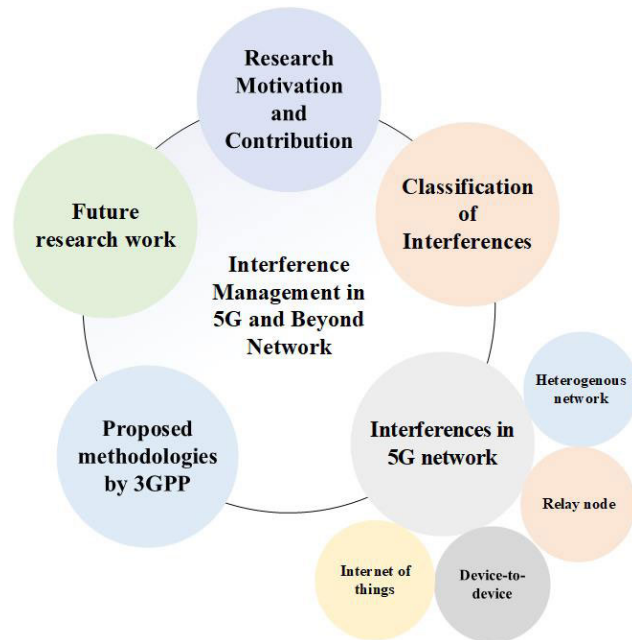

FIGURE 1. Interference management in 5G and beyond network.

The rest of the paper is organized as follows: Section II explains the motivation of this work. Section III begins with the classification of interferences, whereas section IV-A comprehensively discussed HetNet and various types of interferences in HetNet. After that, it discusses some recent related work on interference approaches. Similarly, discussion about RN is exploited in section IV-B, where it briefly described the two major interferences that are always available and reduced the performance capacities, i.e., self-relay interference and inter-relay interference. Additionally, this section provides in detail most of the solutions to mitigate these interferences in literature. Next, section IV-C demonstrates the D2D technique with relevant interference problems. Moreover, it furnishes some techniques proposed by various researchers on the reduction of interferences. Section IV-D contributes to IoT with hindrances that decrease its potential communication capabilities with relevant methods mentioned in several related studies conducted on IoT interferences. Section V provides a discussion about the various methodologies that have been proposed by the 3rd Generation Partnership Project (3GPP) to deal with the 5G interference. Then, future enhancements in available technologies are shown in section VI. In the end, the study is concluded in section VII.

II. RESEARCH MOTIVATION AND CONTRIBUTION

In cellular communication, interference is termed as the addition of an undesired signal in an actual signal. Basically, it is

a modification of a signal in a disruptive way. Interference is different from noise, which can be anything that disturbs the useful signal [28]. Noise can be due to temperature, loud machine voice signals, gamma rays, impurities, and so on. Hence, it is not interference; nevertheless, interference degrades a network's performance and user experience. In the next-generation cellular network with multiple low power nodes, random deployment, and frequency re-use scenarios, the system causes severe interference issues [29]. Therefore, the major challenge of a novel design for a new and feasible spectrum of current 5G cellular systems is interference.

Several researchers discussed the issues of interference and devised various techniques to mitigate the different types of interferences either by coordination, cancellation, or simultaneously. However, the most impactful and inevitable interference in a multi-tier cellular system is Inter-cell interference (ICI). Inter-cell interference coordination (ICIC) was initially implemented as an only solution of a multi-low power BS network. It is separated into coordination methods such as ICIC and enhanced ICIC (eICIC), where the only difference is that the eICIC technique reduces the complicated coordination overhead observed in conventional ICIC [30]. In a practical scenario, the Macro BS coordination generates interference and other management information besides each frequency resource block. This information exchange with neighboring BS via the X2 backhaul interface [31]. Several studies have been proposed and performed on interference coordination, avoidance, and cancellation. However, a proper and robust technique to cancel the interference then drop down the noise level is still demandable in the research community. Therefore, this article investigates and highlights the issues of interferences observed in different structures and techniques of the current 5G network, in which we mainly focus on HetNet, RN, D2D, and IoT to gain new insights into designing efficient 5G and beyond as well as 6G networks in the near future.

III. CLASSIFICATION OF INTERFERENCES

In a small cell wireless cellular network, multi-tier interferences are predetermined due to each low power node's specific attributes [32]. It generates and receives continuously unwanted signals from various nearby sources. It is known that the HD (Half Duplex) mode limits a radio communication network's performance since it is transmitted or received at the same frequency. Different from HD, FD (Full Duplex) transmission mode transmits and receives signals simultaneously on the same frequency [33], [34] and is supported by a multi-antenna system that enhances the network capacity and minimizes the round trip data delivery time. However, though HD shows the capabilities to avoid interferences and provide quality signal strength [35], the delay in transmitting and receiving a signal and inefficient use of spectrum makes it undesirable for new radio wireless communication. In contrast, the FD supports higher throughput with lower latency and efficient use of spectrum [36]. Also, it enhances the ergodic capacity [37] and the network secrecy [38];

however, its performance is extremely descended due to interferences. Therefore, a robust and concrete interference mitigation scheme in FD transmission is required to deliver significant results for the practical future mobile network. The most common interferences associated with radio networks are self-, adjacent channel-, intra-, and inter-cell interference. Nonetheless, the mobile network is not limited to only these interferences. Each network is affected by interferences endured by their respective deployment and transmission scenario. Researchers in various literature well discuss the prominent interferences in cellular communication, and some notable studies are as follows.

A. ADJACENT CHANNEL INTERFERENCE

The adjacent channel interference causes when the desired signal is interfered with by the adjacent frequency band (channel) in the same coverage area, as shown in Fig. 2. When the transmitter of small BS or macro BS while transmitting on a channel leaks its energy and signal added to the frequency adjacent to that band [39]. The core reason for adjacent channel interference is the imperfect filtering of a receiver, allowing the nearby frequencies to leak into the passband. However, it can be consist of a passband filter’s tangible design that conducts only a required frequency to pass through it. Therefore, a reliable interference mitigation technique helps to reduce the impact of adjacent channel interference.

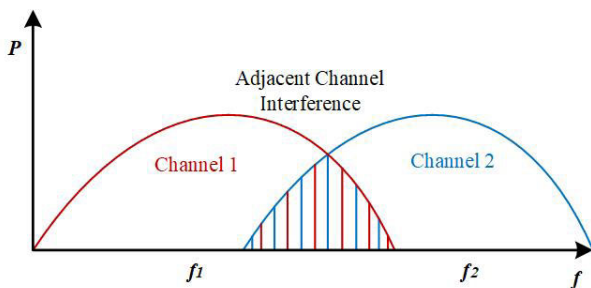

FIGURE 2. Adjacent channel interference.

B. INTRA-CELL AND INTER-CELL INTERFERENCE

Inter-cell interference (ICI) is one of the significant causes of the degradation of network operation. When users of the two neighboring cells attempt to simultaneously use the same frequency band, they received interference signals with the actual message signal [40]. Moreover, the users at the cell edges are badly affected by the ICI because the user received a signal from its cell macro BS with high power and its neighboring cell due to the frequency re-use factor. Fig. 3 shows that macro BS connects directly to the users in the close range and requires low power for the transmission. Due to simultaneous uplink and downlink transmission of many user’s actual data interfere with other signals. The distortion caused by the user to the additional equipment within the same cell is called Intra-cell interference.

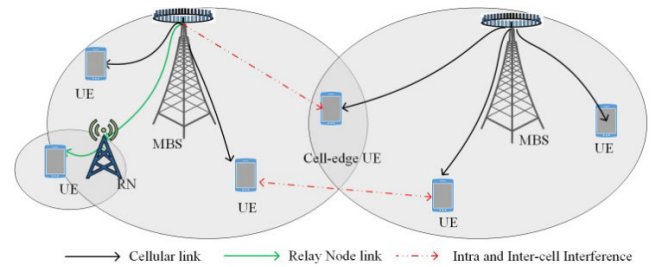

FIGURE 3. Intra-cell and Inter-cell interference.

C. INTRA-CHANNEL INTERFERENCE

Intra-channel interference is vastly observed in multi-low power cells within a macro cell mobile network [41]. It is mostly occurring in an mm-wave HetNet distributed architecture-based scenario. This network relies on self-backhauling using the mm-wave where each small cell BS communicates and forwards the backhaul information to the nearest BS. Then, this multi-hop mm-wave link delivers the data to the gateway. This leads to fast switching and restricts delay in transmission besides propagation losses. Nevertheless, intra-channel interferences induced and affect the useful signal. It is considered a significant issue for HetNet deployment; therefore, a robust mitigation scheme is undoubtedly required to minimize the interference signal to the ground noise level.

D. INTER-CHANNEL INTERFERENCE

The inter-channel interference causes when two separate frequency bands (channel) are causing interference with each other, as shown in Fig. 4 In a HetNet system, multiple wireless and digital communication devices operating in a close range. Due to physical proximity, the transmitter of a high-power signal interferes with a weak signal receiver known as inter-channel interference. In a live network, inter-channel interference is sometimes unavoidable, even when mobile devices’ channels are thousands of megahertz (MHz). A practical example would be a wireless device such as GPS, Wi-Fi, and Bluetooth operating at different channel BW; however, the wide range of transmitting and receive powers of these devices creates various interference issues such as inter-channel interference [42].

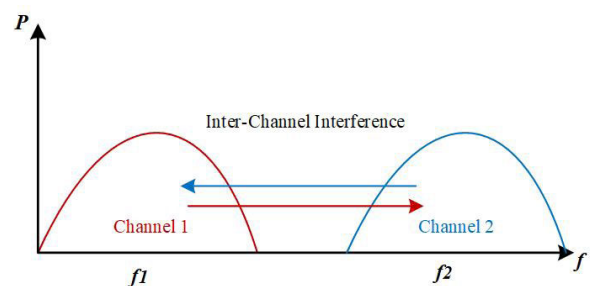

FIGURE 4. Inter-channel interference.

E. INTER-SYMBOL INTERFERENCE

In the propagation of a signal, when one or more symbols interfered with other symbols, signal distortion occurred is formed as Inter-symbol interference (ISI). It is caused by the phase as well as amplitude dispersion in the channel. It is observed due to multipath propagation, and OFDMA is a pertinent example [43].

F. INTER-CARRIER INTERFERENCE

In Orthogonal Frequency Division Multiplexing (OFDM), each channel divides into many subcarriers, and the signals are orthogonal to each other. Thus, orthogonality reduces the importance of the guard band, which enhances spectral efficiency. However, due to the frequency offsets, the signal lost the orthogonality among the subcarriers, resulting in inter-carrier interference [44].

G. INTER-NUMEROLOGY INTERFERENCE

Multiple numerologies are one of the novel 5G wireless communication features. Multiple numerologies like 15, 30, 60, 120, 240 kHz provide essential flexibility for several devices' various services. For instance, lower subcarriers, signals are more suitable for massive machine type communication (mMTC). They supported many connected devices with low power and within the same bandwidth (BW). Similarly, higher numerologies for ultra-reliable low latency communication (URLLC) being their subcarrier spacing is up to 240 kHz, and it provides a shorter symbol duration. Also, intermediate numerologies are productive for enhanced mobile broadband (eMBB) services for higher throughput and significant BW. However, use different subcarrier signals for other applications will generate inter-numerology interference in the network due to non-orthogonality between the multiplexed signals/subcarriers [45].

H. CROSS-LINK INTERFERENCE

When neighboring cells transmit signals in different directions simultaneously on the same or partially overlapping time-frequency resources, it is known as cross-link interference, as shown in Fig. 5. Usually, two types of cross-link interference were observed: transmission-point to transmission-point and UE (User Equipment)-to-UE. The strength of interference power is of wide range, and in some cases, it is much larger than the desired signal [46].

I. INTER BEAM INTERFERENCE

Beamforming is a novel technology used in modern cellular communication. It is a technique that identifies the best route and provides an optimum throughput to a particular user in a specified direction. This approach is essential to compensate for the attenuation losses in transmitting the message signal, especially in mm-wave communication. BS generates multiples of narrow beams of RF energy in all directions of the coverage area. However, the space division of multiple beams introduces inter-beam interference (IBI) [47]. It is

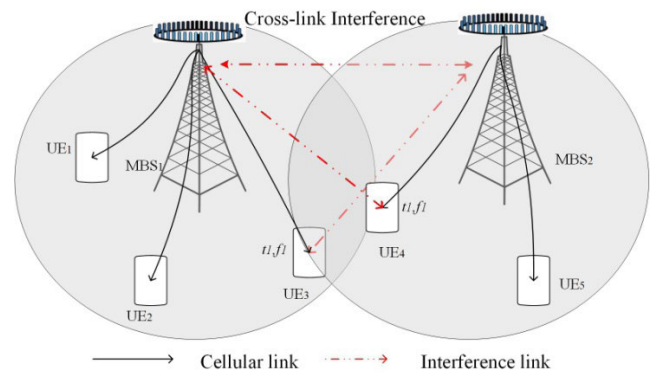

FIGURE 5. Cross-link interference.

caused by the adjacent beams of the BS of the same cell or the neighboring cell as shown in Fig. 6. The essence of beamforming is that it is compatible with both BS and mobile terminal.

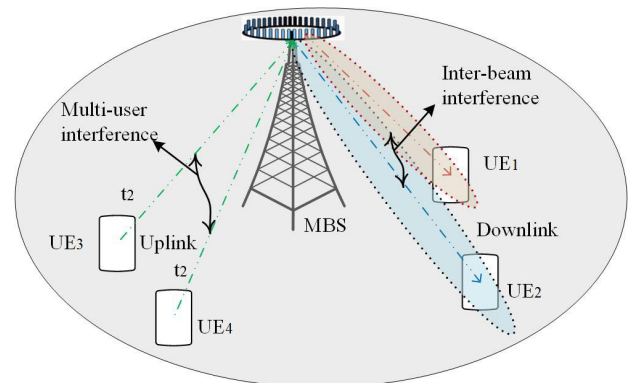

FIGURE 6. Inter-beam and multi-user interference.

J. MULTIPLE ACCESS INTERFERENCE

In many different small cell cellular networks, the same frequency resource blocks carried BS transmitters for simultaneous transmission of useful information. The interference signals are induced in the transmitted signal among the transmission of multiple radio channels in the desired message signal [48]. Multiple access interference is also described as a combination of multi-user and co-channel interference (CCI).

K. MULTI-USER INTERFERENCE

Multi-user interference occurred when multiple users transmit their respective requests of information at once to the closest BS within the same cell (as shown in Fig. 6). Usually, this kind of interference is mostly observed in the radio network, where multiple connections are active in each other's chorus and close vicinity. As new radio, the current 5G is a group of various uncoordinated small cells, and it is foreseen to adjust substantial users with higher bandwidth and lower battery dissipation [49].

IV. INTERFERENCES IN 5G NETWORKS

This section discusses various interference effects in HetNet, RN, D2D, and IoT. It explains various types of interferences

related to each method by studying the state-of-the-art relevant researches in the literature.

A. HETEROGENEOUS NETWORK

The simultaneous operation of varied types of low power BS transmitting and receiving a signal simultaneously from more than 100s of antennas is performed to satisfy the current 5G HetNet technology demand. It is a network designed to support the concurrent operation of multiple technologies. The researchers suggest the unconventional HetNet system's concept to meet the continuous growing user data requisite [50]. Therefore, it presented the HetNet wireless network's idea and believes that the novel HetNet architecture has the potential to fulfill the future demand of both the continuously increasing number of wireless devices and the request for higher data rates. Several types of research were performed for the optimum use of the HetNet structure. In [51], authors proposed that an ultra-dense HetNet cellular network could deliver excellent result when a macro base station (BS) transfers data directly to the users in its proximity that requires low transmission power and provide energy efficiency. Whereas hand off the data to the small cell BSs for the distant users. It triggers to maximize the coverage area than the actual capacity of macro BS and alleviate the dead zone coverage areas [52]. However, the users at cell edges served by the small BS are severely interfered with by intra-cell and inter-cell interference that badly affect the user's performance. Additionally, recent research shows that about two percent of global CO₂ emissions are generated by the information and communication industry. Since energy efficiency is the essential part of current 5G wireless communication, power management of the devices and BSs in designing the new radio 5G HetNet mobile network. Thus, it is considered as an eco-friendly system is referred to as a green energy communication network [53]. Table 1 illustrated fictions of a diverse set of small cells and a macro cell in HetNet.

TABLE 1. Specification of different elements in HetNet.

Types of Nodes	Transmit Power	Coverage Area	Backhaul Link	Environment
Relay	30 dBm	300 m	Wireless	In/Outdoor
Femto-cell	< 23 dBm	< 50 m	Internet IP	Indoor
Pico-cell	23-30 dBm	< 300 m	X2 interface	In/Outdoor
Micro-cell	< 40 dBm	< = 500 m	X2 interface	In/Outdoor
Macro-cell	46 dBm	Few Km	S1 interface	Outdoor

HetNet is based on the random deployment and uncoordinated nature of the small cells. It is critical and challenging to directly forward the backhaul traffic to each small cell node's given gateway. Since the current 5G cellular network touches the untapped region of the mm-wave frequency band that generates tremendous data transfer rate in Gbps and is expected to overcome the limitations. It supports frequency re-use for backhaul links and exceptional data transferring speed than a conventional system. The mm-wave (i.e., 1mm-10mm)

limits the long-distance transmission of a signal but delivers high data transfer speed [54]. Therefore, researchers and industrial operators devised a solution that backhaul traffic is transferred through to a given gateway via multi-hop links by using mm-wave frequency spectrum [55]. This method results in the easiness of the user's handoff issue in small cells because the macro BS only performs the management task. It transmits the information for controlling the user handover in low-power cells. Whereas small BSs are solely responsible for user data transmission.

The most concerning issue in the FD technique is SI. Numerous SI cancellation methods have been proposed, such as analog or digital interference cancellation that can deliver up to 120 dB SI cancellation and trigger the FD communication over the HetNet structure [56]. Despite that, the continuous transmission of several small cells and multi-hop transmission of data to the user as of direct link and backhaul traffic to gateway created massive congestion issues with destructive interferences, handoff failures, and mobility management problems [57].

The co-existence of 4G and 5G networks introduces two stages of deployment in the current 5G wireless communication i.e., non-standalone (NSA) and standalone (SA) modes [58]. The SA mode is considered for the future release of 3GPP and it is solely based on new packet core architecture instead of relying on 4G Evolved Packet Core (EPC). Whereas NSA 5G network is an ongoing 3GPP standardization process to implement the draft standard commercially with the existing 4G cellular network. The concurrent operation of both the technologies in the initial NSA wireless network enhances spectral efficiency, reduces the 5G network cost, and provides seamless coverage yet exposed to user mobility and results in radio link failure and handover probability.

A viable and durable combined interference coordination, management, or mitigation scheme as shown in Fig. 7 needs to be addressed to manage these issues.

1) INTERFERENCES IN HetNet

HetNet is a promising technology for the current 5G radio communication, which suffers from various types of interferences [59]. This ultra-dense small cell system is extremely devastated by the inter-cell, intra-cell, adjacent-channel, self, inter-channel interferences because of unsystematic and unorganized network design. It is observed from development on ultra-dense small cell networks that ICI in the current 5G HetNet can be increased twice compared to the conventional cellular network design [60]. Consequently, ICI's intensiveness in the current 5G multi-cell low power BS is very high, and the features posed by ICI in its predecessor's mobile technologies somehow vary with the new radio 5G network. Therefore, an advanced ICI management and mitigation technique would be developed for next-generation cellular technology. Besides, cancellation of all other vulnerable interferences to maintain high QoS and fairness among the users in a cellular network.

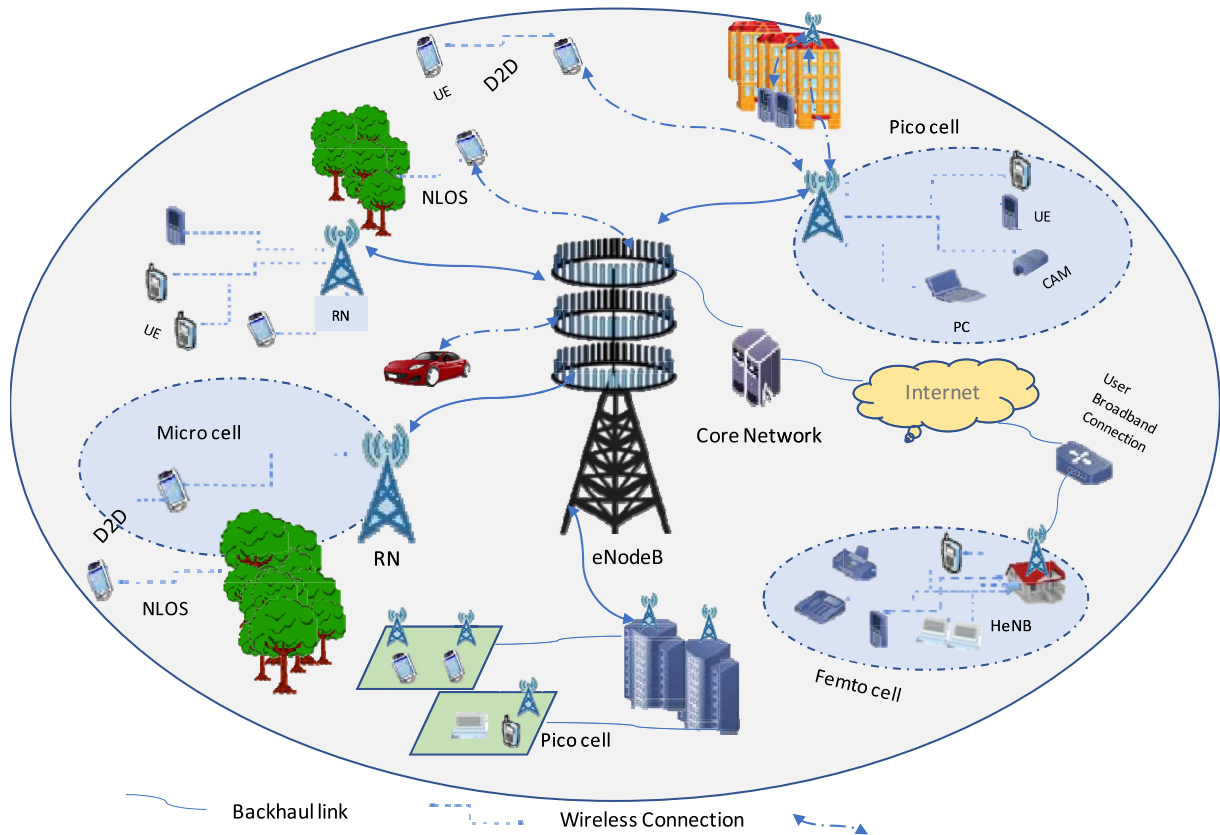

FIGURE 7. 5G cellular HetNet structure.

Due to the concurrent operation of numerous small cells of and within these cells, multiple machine types or small gadgets or smartphones communicate with each other in a macro BS in the HetNet environment causes co-tier, cross-tier interferences (as shown in Fig. 8) [61]. These interferences are mostly observed in a large gathering where many users require higher throughput, such as heavy data applications, internet surfing, downloading and uploading photos, videos, and so on. Those interferences that are precisely involved within the multi-tier heterogeneity structure of mobile network are as follows,

2) CO-TIER INTERFERENCE

Co-tier interference is observed when both users reside in the same network tier. In this case, an uplink transmission femto user belongs to one cell could be the reason for interference to an adjacent femto BS i.e., in the closest range of femto user. Femto-cell transmission coverage short-area approximately 50m. Therefore, it is unavoidable where multiple femto BS installs, and an ample number of users access the link [62].

3) CROSS-TIER INTERFERENCE

In this scenario, users belong to dissimilar network tiers.

Macro user exists in the femto access point to generate uplink interference to that femto BS. Similarly, when a user

inhabits the femto BS coverage area, it lies close to the macro BS coverage area. The femto user creates cross-tier interference with a macro BS. Usually, in the cross-tier downlink, interference is received when macro BS at a distant location to the macro user but close to the femto access point received interference [63]. As macro BS power is very low and the closest femto BS is in a close radius, it will generate high downlink interference to the macro user.

4) CONTROL CHANNEL INTERFERENCE

Control channel carries scheduling and synchronization information for downlink and uplink data channels besides HARQ ACK/NAK information for uplink data channel [64]. It holds the information over a physical channel. While transmitting information over a physical channel, different user's control may get interfered with each other. As carrying the control data on the same physical medium will induce interferences and the user can be received packets in unsynchronized order and data corrupted. Hence, the negative acknowledgment sends back to the serving BS and data of a particular user re-schedule.

5) RESEARCH WORK OF HetNet IN LITERATURE

The authors in [65] propose an approach based on self-organized HetNet that focuses on maximizing the QoS. It is

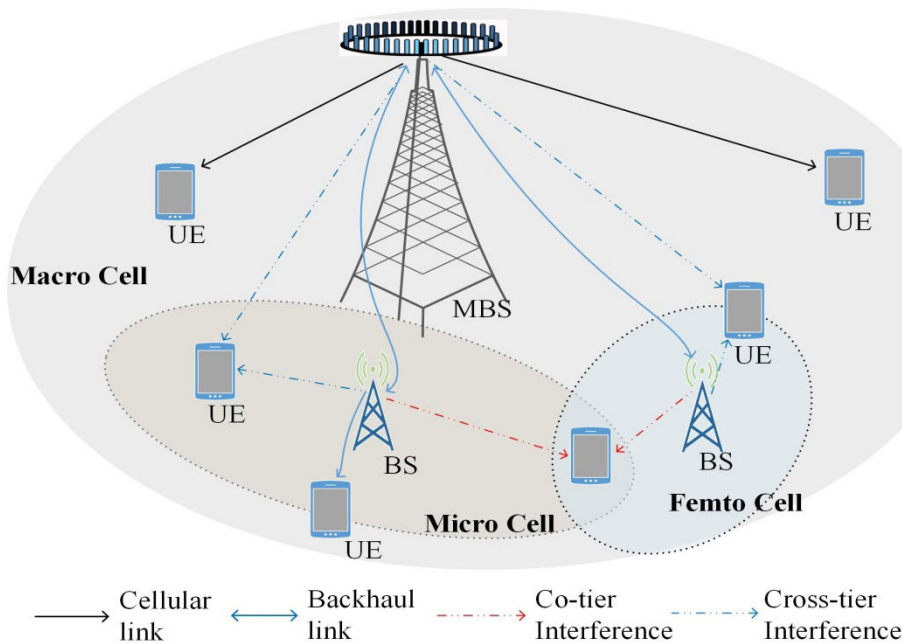

FIGURE 8. Co-tier & cross-tier interferences cellular HetNet structure.

based on game theory that effectively implemented the muting technique of cell time transmission. Therefore, it provides good QoS and authenticates users. Besides, in [66], the authors explored the issue of small cells (SCs) with network flying platforms (NFP) within the consideration of all possible limitations. They execute two methods; the first is an association between SCs and NFPs to reduce total interference while targeting each SC throughput via HBI/MTI. The second form associates NFPs with SCs decay the system's overall interference in an account of the total sum rate by MTILBLS. The simulation results advocate that the proposed algorithm produced impressive results. However, in [67] authors discussed improving the SINR level by reducing interference. To rectify the affair, the SFR approach, besides the non-uniform SBS distribution, was furnished. Also, uniform and non-uniform distribution scenarios were considered for expressions of coverage probabilities.

Consequently, simulations addressed that the suggested model delivered quality results by using the SFR scheme. Similarly, SFR with a non-uniform SBS setup increases coverage probability due to fewer interference problems. Moreover, increment in MBS and SBS densities leads to a harmful effect on coverage probability, but decreasing the SINR threshold value provides better coverage because of the increased number of associated users. The investigators in [68] address inter- and intra- channel interference in the existence of femtocells within the macro cell. It presented the FFR (Fractional Frequency re-use) technique and divided the cell into the edge and central region. The method implemented as the central region users i.e., inner region, has given the same frequency sub-band, whereas outer region users

are assigned different frequency channels. As a result, ICIC prominently decreased, and the aggregate data rate of the cell reached 100% and a 20% reduction in outage probability. Thus, simulations confirmed that the FFR procedure improved the performance of the HetNet cellular system.

With the advent of mm-wave and microwave frequency bands, the network operators can implement multi-antenna cellular phones and provide higher bandwidth with seamless coverage for each user. The 3GPP organization is working to completely implement access and backhaul transmission of cellular traffic on FD wireless mode, but frequency reuse and multi-numerology configuration activate intra-channel interference. Therefore, in [69] authors proposed an impactful solution for intra-channel interference in mm-wave backhaul connection in the HetNet system. It furnished an orthogonal channel allocation, efficient mm-wave access point deployment, and optimal power transmission allocation for reducing complexities of mesh backhaul links. Consequently, the Ray-tracing based simulation shows that the anticipated method reduces interference up to 250m from mm-wave GW. The authors in [70] proposed a PA-based interference alignment (IA) scheme and coordinated beamforming (PA-IA-CB). This scheme was devised for power allocation and interference mitigation issues for the downlink NOMA-MIMO technique in HetNet. Hence, the simulation results validate the proposed concept's performance based on the system sum-rate and outage probability at different SNRs compared to the traditional method (MIMO-OMA). In [71], the authors focus on managing cross-tier interference by deploying small moving cells. They designed a mechanism in which S-UEs' interference channel is signified by the

dominant channel space followed by applying ZFBF in the dominant channel space. Therefore, the simulation results proved that the proposed technique is efficient enough for M-UEs and S-UEs.

In [72], authors raise the concern of multi-tier interference in HetNet uplink transmission. It designed a prioritized radio-access scheme that relies on frequency hopping procedures. The advantages of the suggested scheme that the SC-user has low BER performance and high radio-access priority. Whereas MC-user received relatively poor performance but surpassed conventional FD. As a result, the proposed FH method assured higher anti-interference and spectral efficiency than traditional FH. In [73], the authors proposed a plan, a sub-channel assignment for SWIPT-NOMA in the HetNet downlink case with imperfect channel state information (CSI). The yield of both techniques is the improvement of EE of the cellular network. Thus, numerical results simplified as the proposed algorithm delivers quality performance based on numbers of PUs/FUs, average EE of low power cells compared to conventional NOMA. Whereas in [74] authors proposed a novel real-time dynamic user (UE) association algorithm for multi small cell networks. It develops a location-based interference mitigation algorithm. The algorithm helps to mitigate co-tier and cross-tier interferences. Consequently, computational results proved that the furnished algorithm leads to better performance compared to the other algorithms. Researchers added that their results are applicable in a real wireless network environment for current 5G systems. In [75] authors worked on interference mitigation and network capacity enhancement by investigating old IA schemes. An RCIA algorithm was proposed for the Multi-cell MIMO downlink HetNet. The outcome shows that the suggested scheme delivers excellent performance in spectral efficiency compared to the TDMA technique.

Furthermore, the authors addressed the case of interferences, i.e., co-tier and cross-tier in the two-tier femtocell (FC) network, by introducing a hybrid dynamic ICIC scheme [76]. To gain each user utility and maximizes radio resources, two algorithms have been conceived i.e., FBS-level and FMS-level. The proposed schemes' prominent services are Low computational complexity of the FMS-level and distributed functionality of the FBS-level. To evaluate the performance of suggested techniques, the PF and Hungarian scheduler were used. Consequently, the PF scheduler with the recommended approach gives excellent performance compared to static and semi-static ICIC methods. Also, it delivers high cell-edge user quality and capacity and fairness among all the users in the macro cell. Whereas in [77], the examiner raises an issue of interference in shared spectrum resources. They developed a modified firefly algorithm (FA), i.e. discrete firefly algorithm (DFA) to reduce the co-tier and cross-tier interferences and ideal resource allocation in the shared spectrum HetNet. The experimental results proved that the DFA scheme performed better than the random resource allocation technique. Also, it minimizes the interferences if users utilize the same resource blocks

in the femtocell network. In [78], investigators focused on improving beamforming vectors and power allocation for security rate enhancement by worst-case formulation in two-tier multi-antenna relay-assisted HetNet. Additionally, researchers devised an interference nulling strategy to minimize CCI. Hence, it concludes that the proposed method showed high reliability to accomplish secure communication from experimental results.

In [79] authors explored objectives are to increase network performance based on energy efficiency and throughput alongside a reduction in the interferences. It formulated particular algorithms for a possible combination of eICIC parameters. Thus, the Relaxed-ABS algorithm removes interference via resource allocation parameters such as subframes allocation and average airtime. To validate an algorithm's performance, simulation results prove that Relaxed ABS achieve a prominent gain in energy efficiency. Nonetheless, further modification in the method by blending eICIC and Coordinated Multipoint (CoMP) improved overall system performance. Since 5G and beyond expected to overcome the energy consumption issues thus, several numerical and practical analysis has been performed by explorers for green communication. In another paper [80], researchers address the shortcomings of power consumption and CCI among the small cells in a dense HetNet 5G system. They apply a novel design of ICR that relies on low power cell on/off switching algorithm. Furthermore, to curtail UE's measurements' total quantity, network adjacency matrix (NAM) with the interference coordination rate (ICR) calculation method is merged. Consequently, the unconventional algorithm brings excellent power efficiency to the SBS. Besides, it decreases CCI between small cells with lower traffic loss compared to conventional switching strategies.

Table 2 shows the summary of the research work of HetNet in the literature discussed in this section.

B. RELAY NODE

A few years back, a promising technology for next-generation wireless communication was introduced, now known as an RN [81]. 3GPP presented this concept in Rel-10 to solve performance issues such as slower data rate, more significant delay, weaker signal, higher interference (self, inter-cell, intra-cell), and so on RN is the least expensive low power BS that provides enhanced coverage, greater capacity for the users, and increased throughput, especially at the cell edges. In 4G technology, relays help to give a reasonable data rate to the users in those areas where macro BS did not support acceptable throughput [82]. RN was initially introduced as a switching BS that extends Macro BS's coverage zone and alleviates the hardware installation cost. However, the academic researchers and industrial experts performed extensive researches. They advised that RN can be applied in cellular communication to enhance throughput, energy efficiency, system capacity besides decreasing power consumption. The relay channel communication provides higher data rate coverage to the cell edge users for mobile

TABLE 2. Summary of research work of HetNet in literature.

Problem/Issue	Methodology	Outcome/Advantages	Limitation/Future Work	References
Aim to maximize the QoS & mitigate ICI for self-organized HetNet	A game theory approach that optimized cell time transmission muting and user attachment with dynamic eICIC technique was presented to support the higher number of high data-intensive quality video services and fairness	The user satisfaction ratio (USR) reported that at 100% of HAS clients request HD videos, the QoS mode provides better USR than SLR mode and achieved a USR gain of 3.5% with USR=46.6%. Subsequently, in the case of 100% of users demand SD videos, both optimization modes brought enhancement and gained the same USR of 78.6% with an identical increase of 3.5%	Investigate the optimal installation of QoS eICIC over SDN controlled 5G mobile networks	[65]
Analyzed the issue of small cells (SCs) with NFPs in an account of all related constraints	The bipartite matching and local search-based algorithms, i.e., Hungarian based initial minimum total interference (HBIMTI for each SC fairness) and Minimize total interference based on local search (MTIBLS for high system performance) was proposed	The defined techniques achieved near an optimal solution and reduced complexities. The simulation parameters showed that the returned total interference form LLP using Gurobi=9 and in this HBIMTI returns optimal output whereas MTIBLS achieved total sum rate=23 and total interference=7 means that total intrusions were reduced	The power consumption and mobility of NFPs were not considered and would be a good future learning challenge	[66]
Discussed the SINR of the offloading user's issue due to interferences from MBS to SBS in an ultra-dense HetNet	A soft frequency reuse (SFR) scheme with nonuniform SBS deployment presented to resilient the interference and improved the coverage probability	Simulation results showed that MBS coverage terrain is about 70% of radius for edge coverage range of MBS	This research can be used to find the most favorable value of β to achieve efficient load balancing	[67]
Examined the case of intra- and inter-channel interference in HeNB within the macrocell	An FFR model designed by assigning different frequency channels for both center and edge UEs	Significantly reduced interference level and sum-rate of the cell increased to 100% and OP reduced to 20%	This research can be further explored for mobile users with user's fairness as a constraint and adaptability of center region space and resource allocation can be dynamically handled as per user's mobility	[68]
Evaluated the intra-channel interference in mm-wave mesh backhaul networks	Multiple approaches considered, such as installation of mm-wave access points (APs), orthogonal channel, and optimal power transmission allocation techniques	In without route-multiplexing case, the proposed method reduced interference up to 250m from mm-wave GW. It also applicable for dynamic interference managements without full searches	It would be interesting to performed experiments of the presented method in a real-world scenario to corroborate the effectiveness	[69]
Investigated the dual interference mitigation and PA concerned for downlink (DL) NOMA-MIMO HetNet system	PA-based interference alignment and coordinated beamforming (PA-IA-CB) approach to eliminates co-tier and cross-tier interference	The graph values proved that the system sum-rate and OP of PA-IA-CB are lower than those of OMA and NOMA for all SNR levels. Existing IA-CB provides a higher sum-rate at SNR=45dB and larger; it needs at least 2 orthogonal frequency resources for MC and SC	The complexity of the algorithm is high	[70]
Studied cross-tier interference in the presence of small moving cells	S-UEs based on dominant channel space with a minimal rank after that employed the ZFBF process	Computer test confirmed that the designed scheme performed better for M-UEs and S-UEs	The effect of interference is higher for bigger cell size	[71]
Explored multi-tier interference in HetNet uplink (UL) system	A prioritized radio-access solution considered based on a frequency hopping (FH) pattern with multi-level Hamming correlation	Under the imperfect power control over the cross-tier proposed algorithm guaranteed higher spectrum efficiency (SE) and non-interference capabilities than existing FH / Numerical figures given as BER of SC-user versus Tx power of MC-users were plotted for different K values at SNR=10dB and $\gamma = P^{MC}/P^{SC}$ in case of practical HetNet UL. The graph values also presented the SE of MC-users and SC-users for their Tx power ratios $\gamma = 2\text{dB}$ and 10dB	General case of FH with flexible multi-level access priorities would be a good reason to explore further	[72]
Studied energy management issues of mobile devices in 5G networks due to limited battery size in consideration of inter-user interference	A subchannel assignment problem for Simultaneous wireless information and power transfer (SWIPT)-NOMA along with Mus and PBS/FBS based HetNets in DL with imperfect CSI	Numerical values validated the performance in terms of the number of PUs/FUs and average energy efficiency (EE) of pico and femto-cells compared to OFDMA and conventional NOMA practice. Simulation test simplify to understand that when the number of users=40, EE with $\sigma_e^2=0.0005$ is 3% of the proposed algorithm which is higher than $\sigma_e^2=0.005$ and 31% higher than that with $\sigma_e^2=0.005$	The interference effect of PUs/FUs degraded the overall performance of the network	[73]

TABLE 2. (Continued.) Summary of research work of HetNet in literature.

Reflect the new 3D 5G multi-tier HetNet communication system with co-tier and cross-tier interferences	A new real-time dynamic user association algorithm with the assistance of a location-based interference mitigation scheme and derived expression for the coverage probability	A bar graph results showed the comparison of the sum of interference ($I_{12}+I_{13}+I_{23}+I_{14}+I_{24}+I_{34}$) for core Micro BSs for seven BSs using two threshold levels($\gamma_s=0.005, 0.008$ watts) and confirmed that chosen threshold directly proportional to the sum of interferences	To conduct a new user association algorithm test and apply it in practical case the UE's stack must be modified	[74]
Objective to minimize interference by IA for multi-cell MIMO DL two-layered HetNet	A regional centralized interference alignment (RCIA) by expanding the grouping-based IA (GIA) algorithm along with two-cascade Tx BF matrices at MBSs and Rx BF for PUEs and MUEs	RCIA has better capacity in maintaining SE than TDMA schemes. Results show that the SE-RCIA achieved 80 bps/Hz data with SNR=40dB in different number of MUEs	The work will use to design more complex network scenarios with a large number of macro-cells as well as users	[75]
Aim to reduce ICI in two-tier femtocell (FC) networks	A semi-distributed dynamic ICIC approach conducted for interference reduction and FC-BS (FBS) and FC-management system (MS) (FMS) level algorithm used to maximize the utility of individual users	The proposed solution's simulation values achieved 53% and 50% cell-edge throughput gains compared to reuse-3 and semi-static ICIC schemes (with 3 dominant interferers restricted). Moreover, it gained approximately 44% and 32% peak UE data rate compared to semi-static ICIC	The cell-edge user performance can compromise system capacity and user fairness of a higher number of users	[76]
To tackle heavy interferences and maximize SINR value in shared spectrum resources	A modified namely discrete firefly optimization algorithm (DFA) for efficient resource allocation to achieve the better SINR value than arbitrary allocation	Simulation results expressed that an increased number of iterations increased the chances of appropriate RBs allocation and interferences could be mitigated and increased SINR level. For the firefly algorithm in the last iteration, the average SINR value of all FUEs could be achieved was 75.96dB	A more improved scheme would provide a better SINR value than the proposed scheme	[77]
Studied the physical layer security in a two-tier relay assisted HetNet system	An artificial noise (AN) technique was exploited to deceive the eavesdroppers and constructed an interference nulling strategy to eliminate CCI; also, second-order cone programming (SOCP) problem	The secrecy rate graph versus total power constraint of the MBS and multi-antenna relay (MR) station received values as: For $P_M=10$ dB and 5 dB with $k=2$, the secrecy rate= 0.6 & 0.47 bps/Hz, respectively. Besides, when $P_R= 10$ dB & 5dB with $k=2$, the secrecy rate= 0.6 & 0.2 bps/Hz. Hence, by comparing the two above items, we can see that P_M has a low impact on the secrecy performance than P_R	Consider a case of imperfect CSI at the MBS of the implemented framework	[78]
To increase the network performance based on throughput and energy efficiency (EE) while reducing the interference	A simple ABS algorithm coupled with the eICIC technique was furnished to attain exceptional EE gain on the cost of the system throughput.	Analytical values of EE and average throughput line graph is given as for minimum 10 users achieved average throughput is 352.91 Mbps and EE=8.60%; whereas for maximum 1000 users, the average throughput= 3.33 Mbps and EE=22.87%	A modification with joint use of eICIC with CoMP would help to escalate the LTE network credibility	[79]
Inspect the case of CCI and power consumption of in dense 5G HetNet	Interference coordination rate (ICR) based on small cell on/off switching algorithm incorporation of network adjacency matrix (NAM)	Planned mechanisms help circumvents the complex computational actions besides modifying the EE of SC BSs and decreasing CCI. Also, signaling information between UEs and SC BSs involved in the small cell switching mechanism was reduced	The algorithm can be extended to identify the effect of the mobility of the users	[80]

broadband networks to satisfy advanced RN objectives [83]. Thus, the future network, which is a combination of different sizes of small cells and RNs networks and usage of the mm-wave frequency band, offers a proliferation of throughput and increases energy and spectral efficiency for both cell-center and cell-edge users. Also, multi-hopping through various nodes reduces power consumption as well as delay [84]. Moreover, the RN is also expected to be served as full macro BS at the physical layer, but its range is limited as compared

to the macro BS. This extension in the RN would help to minimize the complexities of high power BS.

Furthermore, the communication between the user and the RN takes place at the same frequency as the communication between the RN and the backhaul link; it is termed as in-band. Contrarily, suppose the backhaul communication performs at a different frequency than the carrier signal utilized by the user for uplink (UL) and downlink (DL). In that case, the RN is known as out-band [85]. However, out-band relays

need more resource blocks since two channels are required for the access and backhaul links. Due to limited spectrum resources, this technique is completely undesirable, and in-band relay has been the focal point of 3GPP and future wireless communication [86].

In the mm-wave HetNet design, RN's efficient use plays an integral part in transmitting a signal from Macro BS and small cells BS. RN in full-duplex (FD) transmission mode is considered to perform far better than (half-duplex) HD mode. However, many techniques had been devised to use HD mode to resolve resource wastage and support extensive data demand for the billions of devices for future wireless communication, such as two-way relaying (TWR) [87]. However, HD relaying immensely increases the transmission and algorithmic complexities of the network. Whereas FD relaying (FDR) provides fewer complexities at the MAC layer, greater spectral efficiency, and well-organized resource management and supports various resource allocation techniques for efficient use of resources without loss of throughput in unfavorable propagation channel conditions. This cause massive congestion due to a large number of assorted devices, hidden terminal, signal penetration due to the structure of the high rise buildings and large advertising objects such as billboards [88]. However, FD and multi-tier HetNet induce various interference issues. The most prominent interferences in in-band FDR are self-, inter-relay, and inter-cell interferences [89], [90].

1) INTERFERENCES IN RELAY NODE

Interferences are a critical and unavoidable part of a cellular network. In wireless communication, it is dealt with in two ways: coordination or cancellation techniques. The interferences observed in RN are described below with related works.

2) RELAY SELF INTERFERENCE

The wireless transmission technique FD is capable of receiving a signal and transmitting it simultaneously on the same channel. This dramatically enhances the spectral efficiency up to 2 times more than HD relaying (that uses two channels). The most promising technology of a current 5G cellular network is the mm-wave spectrum. For massive data rates, ultra-reliable low latency, and minimum transmit power, mm-wave is supposed to be an efficient technique for wireless front and backhaul links. However, due to its limited transmission length, higher spectrum bands (above 24GHz) are badly exposed to propagation losses and fading issues. Therefore, standardization authorities and academic researchers believe that FDR is the most viable option to expand the coverage limit [91]. The implementation of FDR with mm-wave signals induced SI. It is the interference caused explicitly by the transmitter to the receiver antenna located in the same equipment. This should be reduced to a minimum, at most below the receiver's noise power level, such as in [92], the authors designed mm-wave end-fire FDR antennas for SI suppression. Similarly, In [93], the authors proposed the SC-FDE-based FDR method and showed an optimum result

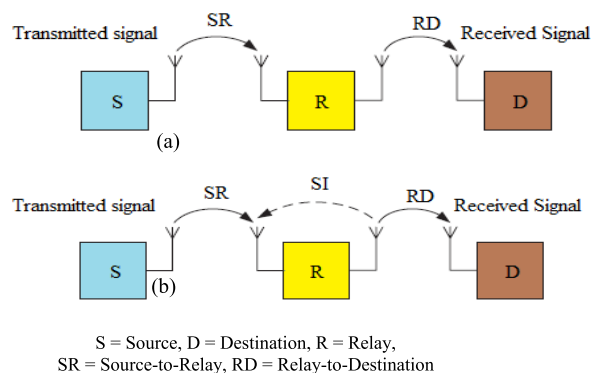

FIGURE 9. (a) Co-tier Ideal FDR (b) FDR with SI.

of the amplifying aspect at the RN, where there is no need for residual SI cancellation.

Fig. 9(a). FDR supports the concurrent transmission and reception of a signal, resulting in a broadcast from the primary BS in which multiple access phases are synchronized. Ideal relaying that delivers precisely the output of its input signal is realistically unachievable. In Fig. 9(b), the FDR experiences strong SI from its antenna receiver node, whereas interferences from other sources would be a part of a transmitted signal.

3) INTER-RELAY INTERFERENCE

In a multi small cell and relays network within a macro cell, FD transmission mode increases throughput, yet it experiences inter-relay interferences (IRI). The relay collects the source data, but it interferes with the other relay's signal. This phenomenon is mostly observed at the cell edges when two neighboring cells use the same set of frequencies. Due to the RN's high transmission power, the relays are affected by the interferences between them. Sometimes during the bench-test, it is observed that the low power transmission of RN can still disturb the 133 neighboring RN. And this problem drastically lowers the user's data and network quality. In [94], the authors suggested the IRI mitigation technique for the two-hop relay. They proposed a method in which the IRI cancellation was executed at the RN to minimize the detection complexity at the destination point. Results proved that the recommended way delivers better performance than the existing schemes.

In a current 5G radio network, a complex combination of several small cells with FDR supports the user's demand, but other sources' disturbance reduces the user's experience [95]. Several types of interference can be possible in a single RN (as shown in Fig. 10). Therefore, an efficient interference cancellation scheme minimizes latency to less than one millisecond and provides higher throughput at multiple Gigabits per second (Gbps) to support next-generation applications highly desirable.

4) RESEARCH WORK OF RELAY NODE IN LITERATURE

Various studies have been conducted on the management and mitigation of relay interference since its introduction in

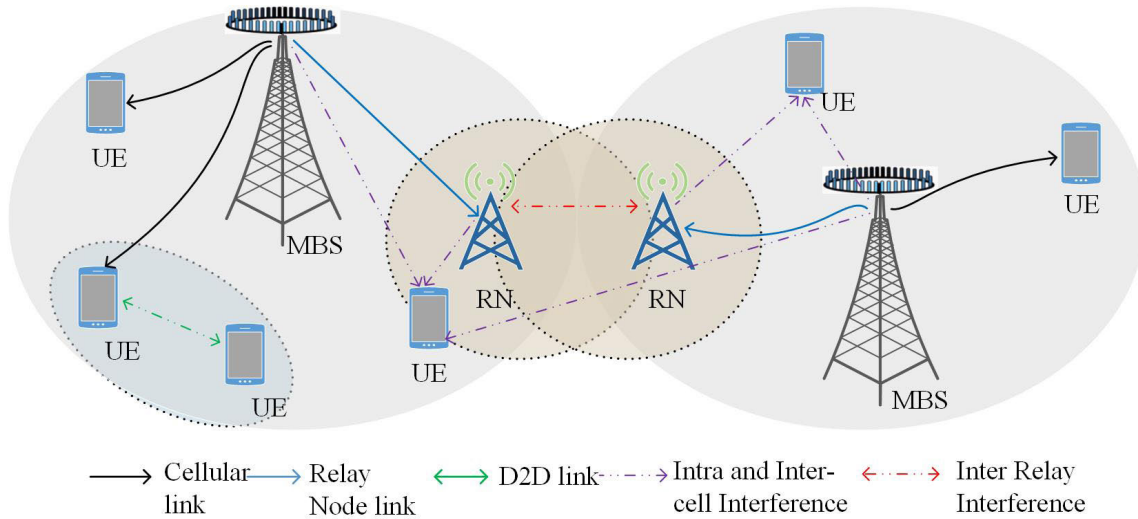

FIGURE 10. IRI, ICI, RN, and D2D links in RN.

mobile networking. Few research methods to rectify RSI, IRI, and other interferences in RN are discussed below.

In [96], the authors proposed a scheme EH-FD-NOMA system with amplify and forward FDR to examine the performance of a system and take measures for SI. The Monte Carlo simulation is used to describe the numerical outcomes. Therefore, results show that implementing PB with high transmit power and SI cancellation for FD will improve throughput and outage performance of near and far users. In [97], the authors furnish a framework to assess FDR's ergodic capacity in vehicle communication. Both CCI and SI were taken into consideration at the destination and relay, respectively. Precisely, the calculation performed on the vehicular-to-vehicular radio cooperative communications with FD non-generative AF relaying system with independent non-identically distributed (i.n.i.d) Nakagami-m fading channels. The closed-form expression of the ergodic capacity was also presented. The outcomes confirmed that system performance decreased while the increase in SI at the relay and CCI at the destination. Additionally, the suitable placement of the relay is suggested precisely in the middle of the source to the destination link. The results proved that when the user is closer to the receiver side, ergodic capacity decreases; thus, the system's performance degrades. However, in [98] authors worked to inspect the impact of in-band FDR of amplifying and forward mode with imperfect transceiver such as damage in electronic component alongside the effect of residual SI. The numerical and simulation results demonstrate that both SI and hardware impairments significantly impact system performance. Hence a robust optimal power allocation technique offered that effectively upgraded system performance. Nonetheless, when the network is badly affected by SI and hardware malfunction, the proposed method could not guarantee expected network efficiency. Therefore, there is room for an advanced solution is desirable.

As the next-generation network is considered to connect billions of devices within a single-tier network, it is predicted that the capacity and QoS will be 100 times higher than the traditional network. But, the malfunction in the hardware equipment would decay the performance of the system. Therefore, in [99], the authors analyzed the performance limitation due to disturbance in the transmission of a signal because of faulty hardware in radio communication devices and imperfect SI cancellation in IBFD decode and forward system. The Monte Carlo simulation was performed to corroborate numerical results. As a consequence, the simulation results achieved accurate expression for the system OP and evaluated the influence of RSI and hardware impairment on system performance to overcome inadequacies of earlier related works. In [100], the authors examine the IRI issue in the CSS TPSR protocol. It focuses on MLC signals for IRI mitigation, whereas simulation results validate the suggested method's BER performance. In conclusion, an innovative scheme helps to mitigate IRI in FD transmission even in severe IRI environments. In [101], the authors investigated the scrambling technique to remove IRI. A novel analytical model presented for a tri-sectorized Hexa shape mobile network. The effect of the scrambling approach on two relays of a sector interference coordination has been discussed. Therefore, the outcome concludes that capacity and throughput are significantly enhanced and the efficiency of access link validated based on SINR and data rate.

Several investigators and industry hardware experts performed numerical, simulation, and test bench tasks on HD and FD transmission performance measurements. And they advised that FD transmission with relaying technique in the next-generation mobile communication is considered to be the optimum technique. Besides, the FD mode tends to support the expected demand for billions of wireless electronic devices. Nonetheless, few of the researchers worked to

provide the same results with unconventional techniques. Like it is presumed that the current 5G wireless communication network is disastrously affected by the interferences. Thus, in [102] authors, demonstrated IRI due to successive transmission of source and relay to another relay and destination links in a network. To fulfill the requirement, two-relay pair selection relies on available CSI in a network that is equipped with a cluster of HD buffer-aided relays, buffer-aided multi-antenna source, and a destination. In global CSI a linear precoding process and CSIR phase alignment strategy are utilized by the source to remove IRI. Numerical results have clearly shown that proposed methods refined performance based on average end-to-end rate and outage probability. Whereas, traditional non-ideal SFD-MMRS technique with IRI is prominently decreased.

In [103], the authors proposed an unconventional virtual FD buffer aided relaying protocol is furnished, and it is categorized by exploiting several SR links. The results indicate that IRI mess commendably suppressed via interference cancellation at the relay with many antenna elements. Results verified by simulation test described that the novel virtual FDR technique delivers minimum latency and sustain sufficient outage probability than existing schemes. Another work demonstrated the IRI disturbance and proposed a new virtual FD cooperative NOMA framework in [104]. A relay station selection algorithm designed with adaptive IRI management and outage probability of a suggested scheme is statistically derived. Thus, simulation outcomes confirmed the more excellent performance of the relay station selection algorithm. Significantly, the proposed framework outperforms the traditional HD NOMA framework. Researchers worked on the mitigation of both interferences related to relay, i.e., IRI and RSI. Subsequently, in [105], authors investigated RSI and IRI for FDR. They are using oblique projection and orthogonal projector techniques to nullify relays interferences. This technique's unique advantage is that if RSI and IRI channels are unknown, it can still be adopted. Thus, the proposed method does not degrade SIR under high transmit power. Once the RSI and IRI are canceled, the FDR mode can be implemented with full potential for next-generation communication. Though in [106], the authors provide quality results for future cellular communication. The authors suggested a framework of several small cell-based macro cell networks with FD mm-wave backhaul links to boost a spectrum's efficiency and attain larger multiple access. An FD mm-wave precoding scheme is offered that enhances spectral efficiency and cuts down interferences simultaneously. By using a three-step precoding design, vastly degrades SI, IRI, BS-UE, and RS-UE interferences. In conclusion, the suggested framework improves cellular network overall throughput, a large number of user support, enhances coverage area, and high data rates for each user with minimum latency.

In [107], the authors discussed the degradation of network performance due to various interferences. A combination of multi-tier small cell structure with FDR transmission mode produces SI, IRI, and RDI. The MIMO FDR assisted a

multi-cell network with a joint BF method to mitigate SI, IRI, and RDI. In particular, all three interferences effects can be removed by relaxing zero-forcing conditions of several null space dimensions implementing IA. It is given that the multi-dimensions can be adjusted in a single dimension where the interference mitigation techniques can be utilized. The MIMO FDR transmission is achievable by effectively canceling the SI, IRI, and RDI and it is further enhanced by the PA algorithm to offer close to twice the standard HD capacity. In [108], the authors focused on analyzing FD interferences with filter and forward-based multiple relays cellular system.

Two strategies are provided for the filter model based on SINR enhancement with a controlled transmission power of relay. The results verified by the simulation test and proved that the FD-FF relay network shows higher reliability than the HD-FF scheme regarding attainable rate. It also described SOS-based filter design techniques that were obtained and their efficacy is given numerically. The articulators in [109] discussed the performance of dual-hop energy harvesting relaying networks under the time switching process in the presence of CCI over Nakagami-m fading channels. This examination explicit the network with and without a direct link. Hence, the expression of data rate and the average bit error probability is evaluated analytically. Numerically calculated analytical results matched with equivalent simulation outcomes justify the effectiveness of the presented analysis. The results conclude that the system performs best on throughput for optimum values of two parameters, such as α and greater values of η . Next, the average bit error probability diminishes with quality channel conditions.

Moreover, nullifying the average bit error probability once the separation between relay and CCIs increases. Hence, the results proved that a direct path system performs much better than without a direct path. Similarly, the explorer in [110] considered secrecy outage performance of decode-and-forward cognitive relay network in the shadow of CCIs. All channels face Rayleigh fading channels and all nodes are furnished with a single antenna. Closed-form secrecy outage probability has been derived from measuring the performance. The Monte Carlo simulation was devised to validate analytical results, where opportunistic scheduling was utilized at the destination. Thus, results corroborate that the employment of several destinations may enhance system secrecy performance. However, an increase in CCIs could minimize the security of the network.

Table 3 shows the summary of the research work of relay nodes in the literature discussed in this section.

C. DEVICE-TO-DEVICE

It is predicted that 100 billion electronic devices can be connected through wireless links by 2030 [111]. This exponential growth in the quantity of the user equipment causes an increment in the frequency spectrum usage. In contrast, the current spectrum lacks the availability of free resource blocks. Therefore, the next generation has all the ingredients

TABLE 3. Summary of research work of relay node in literature.

Problem/Issue	Methodology	Outcome/Advantages	Limitation/Future Work	References
Analyzed the outage probability (OP) and throughput performance for near and far users in the presence of SI	Combination of energy harvesting in FD mode with NOMA technique considered by using plot graph impact of SI cancellation	Results presented and confirmed that with better SIC i.e., -50dB OPs reduce faster and fall down below outage floor. Besides, if RSI is large, i.e., -10 dB, the OPs of both users decrease steadily & stay above the outage floor	Evaluation of scheme is required with more powerful and uncomplicated antenna, circuit design, and analog/digital processing in a real-world scenario	[96]
Investigate FDR's ergodic capacity in V2V communication by optimizing CCI, SI, and relay position	Design a framework for ergodic capacity and derived closed, upper, and lower bound expressions over i.n.i.d Nakagami-m fading channels	The outcome suggested that the best position of relay is in the middle of the source-destination link that would help to assess the practical limits	Network transmission quality significantly decreased with an increase in average CCI and SI/ results	[97]
Network performance assessment of IBFD-AF relay with an imperfect transceiver and residual SI	Derive an optimal power allocation (PA) scheme to reduce OP and symbol error probability. For instance, at -10dB optimal PA must be used but at -30dB if the system requires SEP=10 ⁻³ at SNR=35dB	Greatly enhance the system quality. The computer test presented that to reduce the FD transceiver's complex design, a suitable relay Tx power was selected based on the RSI level obtained. FD transceiver did not require power adjustment and for SNR> 35 dB, if the system required to enhance performance, power optimization can be applied for this event	Heavy SI and more troublesome with hardware components degrade the system robustness/more advanced solutions required	[98]
Understand the impact of imperfect SI cancellation and faulty hardware on the system	Derive exact OP based on SINR and distortion ratio and examined the intelligibility of the system	Through the Monte Carlo test, three results were achieved 1) OP of the system vs PA factor, 2) OP for asymmetrical model P _R =40 dBm, 3) OP of the system vs. SNR. Consequently, HI slightly increase then SNR>20dB and touched outage if SNR=40 dB	Damage transceiver downgrade the reliability and quality of communication and OP fall at very low SI analysis would be helpful in the practical scenario	[99]
To improve chirp spread spectrum (CSS) transmission characteristics in the occurrence of IRI	Two-path successive relaying (TPSR) protocol with multiple linear chirp mechanism was devised	Low BER achieved with coverage expansion and significantly minimized IRI effect even in worst IRI environments. Computer simulation for BER performance chirp time= 1 μs, bitrate=1 Mbps, BW=30 MHz and analyzed the IRI effect with the above parameters	A new scheme could be productive to construct a relay-oriented CSS system for IoT network	[100]
Interference coordination between two relay nodes in a tri-sector LTE-A	The unique Scrambling technique presented to avoid Interference	Significantly enhance the capacity, data rate, and sustainability of access link supported with better SINR	The proposed method can be extended for multiple relay system	[101]
Studied a cooperative network with HD-buffer aided relays in a multi-antenna system	Relay-pair selection policy with linear precoding strategy relied on CSI was applied to increase multiplexing gain and average OP whereas conventional non-ideal SFD-MMRS scheme with IRI degraded.	The bench test showed a round trip rate for various IRI intensities and varying SNR. Such as IRI same intensity= 0 dB, stronger=-3 dB, and weaker= -3dB. Whereas ideal SFD-MMRS almost achieved the upper bound and non-ideal degrades performance	Investigate the case when only statistical information is available about CSI	[102]
Exploit multiple source-relay broadcast channels in the existence of IRI	Virtual FD buffer aided relaying protocol with multiple HD relays was proposed to suppress IRI, reduce latency, increase spectrum efficiency, and maintain minimum OP than other available schemes.	Simulation results validated for OP relay ranges of 2 =< K =< 10, SNR set as 0 dB. Subsequently, average packet delay evaluated with varying SNR from 0 to 30 dB. Also, effects of buffer size L=10 to 100 on achievable OP with SNR set at 0 dB	It is suitable to apply the same technique in multiple interference scenario	[103]
Scrutinized diversity multiplexing tradeoff (DMT) performance	Virtual FD cooperative NOMA framework for downlink two-hop network along with relay selection algorithm and adaptive IRI management	Numerical analysis showed that when ρ=20 dB for K=5, optimal a ₁ for proposed protocol reduces OP=0.45 & resultant OP=9.77x10 ⁻³ . While a ₁ of 2-stage RS selection minimize OP=0.52, resultant OP=2.31x10 ⁻² . When K=10, a ₁ minimize OP=0.45, resultant OP=1.80x10 ⁻⁵ , while 2-stage RS reduce OP=0.52, resultant OP=4.43x10 ⁻⁴ .	The network complexity has been improved	[104]
Interference mitigation for MIMO multi-hop FD relay network	Oblique projection and orthogonal projector processes considered to decrease RSI and IRI in the FDR system, reduce computational complexity, and increase the system's performance	Simulation values showed that the noise effect in the system with SNR=8 and SNR=∞ a small gap found and confirmed that multi-hop networks are interference-limited networks and noise could easily be neglected	Inspect the case with artificial intelligence to boost the reliability, awareness of the network functions	[105]

TABLE 3. (Continued.) Summary of research work of relay node in literature.

Channel characterization and coverage expansion of FD relay mm-wave wireless backhaul	An FD relay-based mm-wave multi-small cell with a 3-step precoding design presented	Improved spectral efficiency and accomplished massive multiple access besides reducing SI and IRI	SI of FD transmission needs further exploration in terms of hardware design and precoding methods	[106]
Mitigation of SI, IRI, and relay-destination interferences (RDI) in MIMO-FD relaying multicell system	Joint power allocation (PA) and ZF-BF was adopted to evaluate OP and ergodic capacity	Proposed technique attained better OP and ergodic capacity than baseline approaches with equal PA (i.e., $P_{SR}=P_{RD-1}$) and considered SNRs symmetrical and affected by noise power $N_0=1$ at all nodes; also revealed that FD-MIMO is superior in system performance than HD-MIMO relay	FD-MIMO results are better as compared to HD-MIMO with a limited number of users	[107]
FD with multiple filter-and-forward (FF) relay networks in the existence of SI, IRI, and ISI in frequency selective channel analyzed	Two methods LI nulling approach and I.I.D approximation approach considered based on SINR maximization; SOS-based filter design scheme was also derived	From simulation results suggest that SINR of both techniques improved as Tx power relay ($P_{max}=P_s=10$ dB and higher than noise power which is 1) increased and maximized within five iterations	Need to develop a filter where no central node exists or individual power limitations for each relay imposed	[108]
Discussed the performance of dual-hop energy harvesting in cooperative relaying network with CCI issue	Derive expressions for PDF, CDF, and MGF of SINR of MRC-SC receiver diversity techniques in terms of bivariate fox-H functions. Also presented average ASEP of dual-hop DF system	Higher throughput for optimal α and larger η values; besides ASEP disparaged with good channel conditions. Results demonstrated that the system with a direct link outperforms without a direct path	Higher interference degraded the overall network performance	[109]
Examine secrecy outage performance of DF cognitive relay network in the availability of CCI	Closed-form expressions of secrecy OP based on SINR were derived	Numerical results showed that OP decreased with an increase in average SINR of the main link and system secrecy performance escalated. Besides, the average SINR of the R-D link is more than the S-R path due to opportunistic scheduling at the end terminal.	Proposed a new integral expression	[110]

to accommodate the massive stipulation. The existing 5G mobile network is a combination of various methods that help to achieve the expected demand. The mm-wave frequency band exploration creates the possibility to fulfill the future user's requisite. With many other techniques, D2D communication is also a promising 5G network [112].

D2D can be useful for the direct connection among nearby disparate devices from heavy electrical machines to smart electronic instruments without utilizing the core network. It can also access both cellular licensed and unlicensed spectrum. It could be considered a substitute for cellular communication for services such as mobile traffic handover, content sharing in meetings, data transmission, vehicle communication, public gatherings, and so on. The fast switching among nearby electrical and electronic components delivers minimum delay, low transmit power, lower propagation losses, and larger throughput besides maximum spectral and energy efficiencies. D2D can also be utilized for future energy-efficient wireless communications [113]. The basic D2D structure in multi-tier HetNet can be seen in Fig. 11.

According to the research community in 2003, the number of connected users to the network was 6.3 billion, though the sum of related smart gadgets per user was 0.08. It reached 4 times more connected devices than its previous number in 2015. Furthermore, in 2020, the connected automated components will touch the number of 50 billion, whereas connected devices per person are going up to 7. The

novel D2D communication can be conducted on a licensed (in-band D2D) and unlicensed (out-band D2D) spectrum. In-band D2D is sub-divided into underlay and overlay modes. In in-band underlay mode, the D2D users utilize the same spectrum resources of cellular users; however, in in-band overlay mode, pre-defined channel resources from the cellular spectrum are allotted to D2D communication [114]. Nonetheless, the in-band overlay mode can only be deployed in particular locations and conditions. Due to the scarcity of spectrum resources, this category would not justify the 5G and beyond requirements. Moreover, to find the suitable candidate for D2D massive research has been performed and all suggested that in-band D2D is reliable, as it maintains a high-security level, improves spectral efficiency, and can be re-used cellular device resources. Therefore, most of the work is performed on the underlay in-band D2D mode. However, many researchers favor the unlicensed band for D2D users with either Bluetooth or Wi-Fi direct [115]. As a result, investigators said that it is viable to operate an out-band D2D configured system for short-range communication using either Wi-Fi Direct or Bluetooth i.e., unlicensed spectrum. On the other hand, long-range transmission used a licensed spectrum such as WLAN, LTE-A, WiMAX, and so on. However, the licensed spectrum can and will create interference issues between cellular and D2D users. As technologies improve at a quick pace and help to craft the cellular network in a more refined shape, recent radio communication advancements

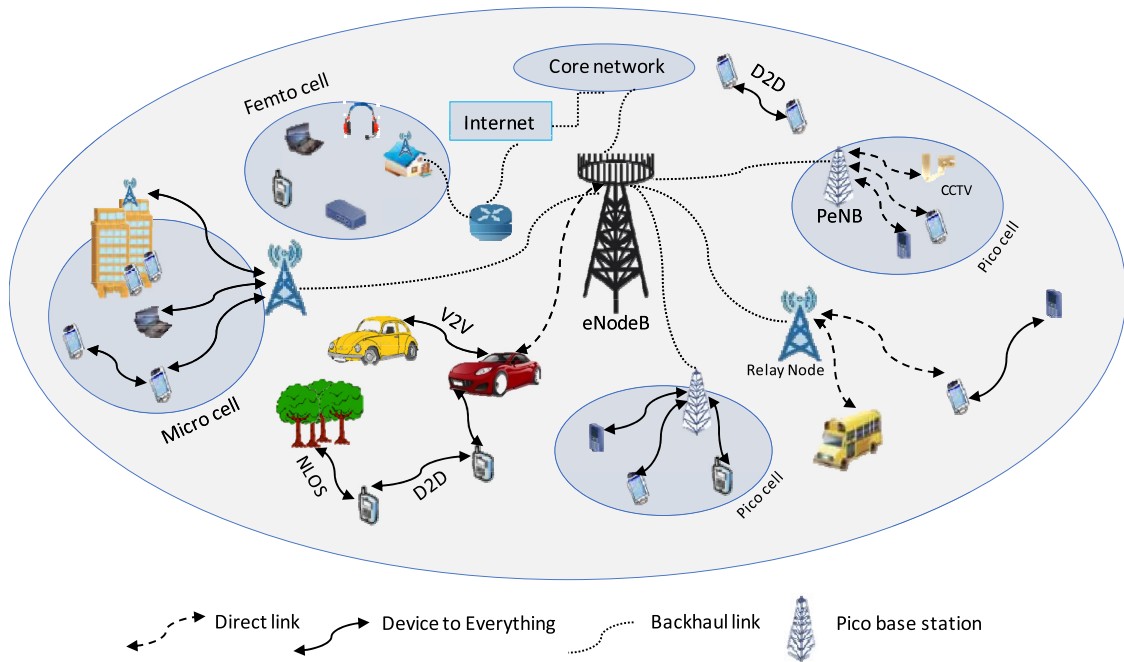

FIGURE 11. D2D communication in multi-tier HetNet.

suggest that D2D users may share the unlicensed spectrum of LTE-A in the same access level within the same network. Therefore, it intelligently exploits the overcrowded licensed spectrum assets, whereas the unlicensed spectrum is managed via coordinated radio resources (CRR) [116]. Nonetheless, data between several D2D users and mobile networks are severely obstructed by the interferences.

1) INTERFERENCES IN D2D

The advent of D2D communication introduces a new tier in the current 5G HetNet cellular system known as the device tier. The device tier involves D2D communication, and devices are randomly distributed in a network. The addition of a device tier in a cellular network significantly enhances the throughput, spectrum efficiency, and battery life of wireless equipment. However, the major challenges involved in the implementation of the D2D link are security and interferences [117]. In the D2D link, the simultaneous connection between 100s of incongruent devices and two-way communication can potentially increase interferences. Also, D2D users could be exposed to data encryption issues. The transmitting data is not encoded correctly due to any hardware or software malfunctioning and the intermediate device easily hacks the information [118]. This could be a possible result in the loss of private and highly confidential details. Thus, D2D communication greatly improves system performance, though it is poorly exposed to security issues. Nonetheless, D2D transmission is highly desirable for the current 5G cellular communication as it takes lower power to transmit from one hop to another and increases the system capacity [119].

Many researchers exploited the security problems and the interferences in D2D enabled cellular networks. Here,

still, the discussion is limited to interferences. Therefore, the authors broadly discussed recent work conducted on the mitigation of interference in D2D. The eminent interferences observed in D2D communication are classified into a network domain, i.e., co-tier, and frequency domain, i.e., cross-tier. [120]. The D2D co-tier interference is observed when a D2D user interferes with another D2D user in the same tier. In an OFDM-OFDMA system, when the same set of subcarriers are allotted to multiple D2D users, co-tier interference is received from the transmitting device to a nearby receiving device. On the other hand, cross-tier interference is generated between the cellular user and D2D user. In the co-existence of D2D and cellular users, the victim of interference is different because of the direction of frequency resource transmission (as shown in Fig. 12).

Scenario 1: In in-band underlay mode and both users transmitting in the uplink direction, the cellular user interfering with the D2D receiver. In contrast, the D2D transmitter signal interferes with the MBS.

Scenario 2: When D2D re-used downstream resources of licensed spectrum, D2D transmitter data interfere with cellular downlink user and MBS high power signal interfere with D2D receivers.

2) RESEARCH WORK OF D2D IN LITERATURE

For handling the interference issues in D2D communication, the most appropriate efforts will be discussed as follows.

In [121], the authors worked on the mitigation of interference between cellular and D2D users. The resource management and power control technique was presented for multicast D2D communication within uplink mobile networks to reduce interference. The sum throughput

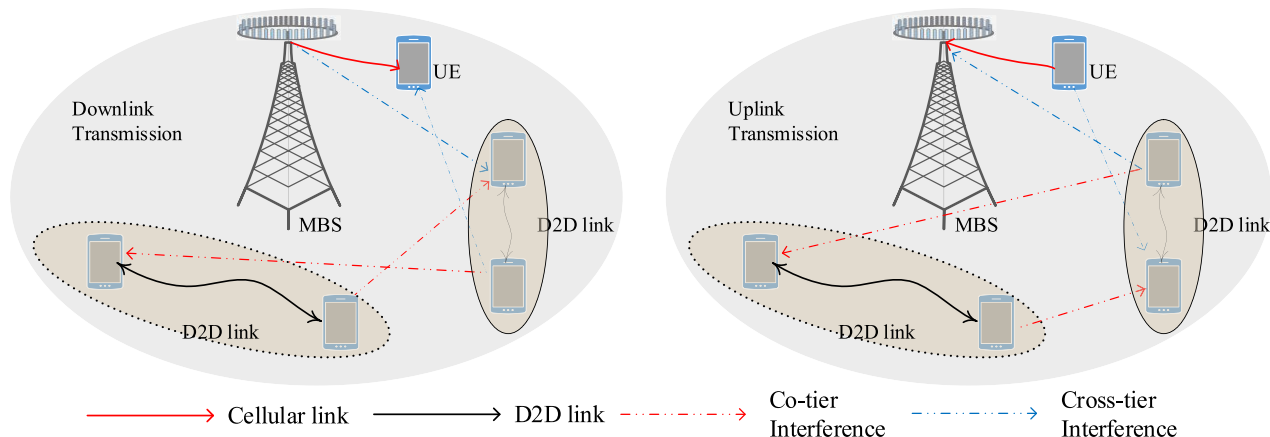

FIGURE 12. D2D interferences in 5G HetNet.

optimization problem’s formulation as per the required power and SINR levels were furnished. To simulate the proposed scheme, a Monte Carlo simulation was applied for the performance measurement. Therefore, simulation results show that the recommended technique performs much better because it achieved higher throughput and reduces overall power consumption compared to conventional schemes. Furthermore, in [122], the authors presented a new idea of utilizing time and space division in resource allocation. Then the study was conducted on the resource management issue in D2D communication underlying mm-wave technology. A time slot scheduling algorithm based on vertex coloring is presented. Hence, the proposed method helped gain higher throughput per time slot impressively, around 12.5%. Additionally, simulation results assist to understand that side lobe interference is a serious threat in the down gradation of the network. However, it can control side lobe interference if properly choose a suitable threshold.

In [123], the authors considered a process to characterize intra-cell interference in the D2D underlay network. The suggested PCP process to model the inhomogeneous and spatially correlated distribution of MTs. Besides, it creates a novel approach to Euler Characteristics (EC) for approximated intractable nearest neighbor distribution function. In consequence, the research findings are

- a) EC and RFT framework helps to identify hotspots for D2D communication.
- b) Point processes with repulsion/attraction property can be utilized for robust spatial modeling of MTs/BSs.
- c) The numerical inference was conducted to detect clusters of MTs with spatial correlation.
- d) Threshold ‘u’ of the jaunt plays a vital role in managing cluster size for D2D communication, coverage probability, frequency re-use, and mobile user’s level of interference.

In [124], the authors discussed the problem of interferences due to resource sharing. An unconventional design of spatially spreading of nodes in HetNet via PPP to explore the impact of co-tier and cross-tier interferences between

D2D and cellular networks due to the sharing of cellular user resources in HetNet considered. Also, a distributed resource allocation algorithm based on matching theory proffer to decay the impact of interferences and enhance network performance. The simulation results advised that the proposed algorithm helped achieve network performance by up to 93.7% and drastically reduced interferences among D2D and cellular users. Alternatively, the articulators investigate the outage performance of D2D communication underlie cellular networks by using BF and IC techniques besides an M-antenna BS in [125]. The research shows that D2D users communicate via a two-way DF relaying and statistical results validate that the relay-assisted network’s outage performance can deliver excellent results than the conventional case without extra power usage. The results also suggest that when the separation between D2D and cellular users is far enough, the outage probability inclines zero. In [126], the authors demonstrated topological interference management (TIM) for D2D communication when devices are unaware of CSI with other devices in the surrounding yet the network topology can cancel the interference observed. Therefore, the simulation results confirmed that descending in signal interference when matrix rank reduction ability is applied. The results showed that the implemented scheme outperforms all existing techniques.

In [127], authors worked on two modalities, i.e., interference management and cancellation projected to AAF relay in the D2D network and a cooperative D2D network in which one of the D2D pair acts as a relay to cellular transmission. The yield of the approaches leads to the conclusion that the cellular user throughput increased by using cooperative relay D2D compared to underlay D2D link. Additionally, the examiners conducted a comparison test between the proposed method with compress and forward relay protocol, where the suggested method decay the BER by 9 dB and outage ratio downsized to 0.002 when D2D count equals 20 pairs. In [128], the authors performed a test on interference minimization to maintain the target sum-rate due to the problem in assigning mobile user resource blocks to D2D pairs. A novel

algorithm technique was presented, and results conclude that if the interferences are uniform, the algorithm takes polynomial time. Similarly, in [129], authors focus on the interference problem in small cell and D2D user's co-existence under the mm-wave transmission. A Stackelberg game-based interference control process with full frequency re-use in D2D link underlaid mm-wave small cell network proposed. The simulation test was performed to verify the presented technique and results proved that the scheme obtains higher throughput and SINR level in full frequency re-use mode. In [130], the author performed energy optimization in the intra-cell and inter-cell interference constraints in D2D communication. A multi-cell joint optimization approach was examined in both the interferences to increase the energy efficiency of cellular and D2D links. Two selected algorithms, i.e., MCJPC and SCIPC, deliver optimum energy efficiency besides greater scalability.

In [131], the authors performed an analysis of coverage probability in D2D. The Nakagami-m fading procedure is used for the study of the performance. The numerical results show a decrease in coverage probability degrades the link quality. Also, a rise in threshold the coverage reduces; therefore, interference can be alleviated. With the simultaneous use of licensed and unlicensed spectrum in D2D assisted wireless links, vehicular communication will be a key feature in 5G and later 6G wireless networks. In [132], the authors discussed the interference analysis for vehicle-assisted communication at mm-wave 28 GHz frequency band. Due to massive vehicles roaming on the road and high mobility of vehicles, they may induce interferences and regular packet loss error. The analysis confirmed that PEP relies on channel non-linearity and multipath clusters. More multipath and delay in arrival time more chances of interferences.

Apart from interference cancellation and suppression techniques, many researchers choose to investigate the interference management method in D2D assisted wireless networks. It is because an interference management approach minimizes the statistical and computational intricacies and effectively reduces the interferences. Thus, in [133], the authors observed interference management in D2D communication within multi-tier cellular HetNet. An interference management scheme is presented in which only D2D UEs in an achievable set can re-use the resources of cellular links. Hence, the proposed method decay interferences and maintain QoS. In [134], the authors exploited the usefulness of D2D communication with the SWIPT energy harvesting method with a target to gain the advantages of three essential enabling technologies of the 5G and beyond networks. Different algorithms such as time and power splitting SWIPT implemented to compared it with existing procedures. In conclusion, the results proved that the underlay D2D in HetNet with shared spectrum resources interferences are more vulnerable than traditional HetNet. In [135], the authors identified an issue of cross-tier interference for underlay D2D users in HetNet assuming imperfect CSI. They have used Fractional programming (FP) to evaluate the ideal power for

CD, MD, and SUE users while ensuring minimum QoS of the macro-cellular user in the existence of channel estimation error. A Lagrangian duality transform was also implemented to reframe the actual power control problem. Consequently, the given algorithm helped provide higher system performance by increasing the separation between CD and SUE. In [136], the authors inspected the reliability of eICIC, focusing on the SE in HetNet. The investigators studied the results of allocation of spectrum resources to MUEs by using D2D to assist the delivery of downlink data when ABS is active to overcome transmission discontinuity. The process is called D2D-eICIC, i.e., a heuristic algorithm. The network sum-rate via simulation results proved that the proposed technique performs far better than traditional eICIC.

Table 4 shows the summary of the research work of D2D in the literature discussed in this section.

D. INTERNET OF THINGS

Generally, the term IoT can be seen as building upon the concept of a Wireless Sensor Network (WSN) [137]. They can sense data, gather it, and afterward send it to the network via a sink (also known as gateway). These low-power devices (sensors) are essentially miniaturized radio communication units with some physical quantity measurement capabilities.

The new radio's evolution in the current 5G HetNet architectural system has made it possible to fulfill the connectivity demand of many IoT devices and their applications. To meet future IoT fundamentals, new, highly desirable parameters, such as security, ultra-reliability, lower round trip delay, the massive connection of unparalleled devices, and throughput, should be optimized for a perfect user experience with minimal disturbances [138]. IoT transforms the world's communication network via the connection of a diverse range of physical objects and handles low-power electronic components that connect one another through the Internet. Energy efficiency is one critical concern in future IoT-enabled wireless communication. The massive connectivity of small to large scale objects and machines will emit an enormous amount of energy in the environment. According to Ericsson [139], approximately 28 billion smart wireless devices will connect through the internet worldwide by 2021, and solely 15 billion devices belong to M2M and consumer types of equipment. IoT is a disruptive technology that enables an environment to utilize the internet in everyday human life, business, and industrial applications. According to the academic explorer, billions of wireless electronic instruments and heavy machines can run on massive IoT applications, for instance, smart homes and buildings, intelligent grid systems, agriculture monitoring and maintenance, smart cities infrastructure, and so on [140].

In general, IoT applications and services are productive where updates are required on the cloud and perform indoor office or smart home surveillance, including things like an automatic door lock to garage gate opening on arrival. In this small-scale environment, IoT can be quickly and effectively deployed with lower end-to-end cost, less energy

TABLE 4. Summary of research work of D2D in literature.

Problem/Issue	Methodology	Outcome/Advantages	Limitation/Future Work	References
Issue of sum throughput maximization problem due to interferences in underlay D2D transmission	A resource management & power control scheme based on frequency reuse besides the FFR method was devised in a multicast D2D link	The proposed scheme outperformed the existing schemes in terms of a) Optimize multicast D2D throughput & interference: the upper & lower bound power levels are defined as maximum Tx power of D2D user=15 dBm & cell-user=25dBm, b) For Cell-throughput: proposed method reduces interference & rise cell-throughput. However, rise in D2D users decreases the cellular user data rate; D2D Rx in a group=1~6 & D2D group count=6, c) System power consumption: given noise power= -174 dBm/Hz & SINR=5dB delineate that achieved lowest power consumption	A method that can maintain the cellular user throughput while an increase in the count of D2D user is demandable	[121]
Examined the resource management issue in D2D link underlay mm-wave channels and understand sidelobe interference threat	Construct a case of time-space division in resource allocation and present time slot scheduling algorithm based on vertex coloring	The analytical test confirmed that throughput/time slot improved 12.5% and will enhance if sidelobe interference could properly control by choosing a suitable threshold (different threshold has a different effect and optimal range is [0.7,0.9])	Improve the same algorithm by using multi-coloring and integrated TDMA/FDMA/SDMA frame structure.	[122]
Lacking homogeneous spatial distribution and inadequacy of SPPP and characterize intra-cell interference in D2D communication	Designed a permanent Cox process (PCP) with the aid of EC to approximate the nearest-neighbor distribution function	1) Configure potential applicants for precise spatial modeling of users/BSs. 2) EC & RFT apt to analyze dense areas for the D2D link. 3) Statistical inference can help to locate clusters of users with high spatial correlation	The large cluster size can affect the interference and coverage probability	[123]
Observed the ever-increasing data traffic, considered the system capacity improvement via the D2D approach	Distributed resource allocation algorithm based on a matching theory with disposal of mutual interferences between cellular & D2D communication	Proposed an idea helped to attain 93.7% when average Tx power of D2D Pairs is 22 dBm of the system performance, decrease interferences as well as extensively reduction in complexity and overhead	The data rate can be enhanced by reducing the complexity of an algorithm	[124]
Investigate the OP of D2D underlie cellular networks for BF and interference cancellation strategies	BF and interference elimination with M-antenna elements at BS was planned	Relay assisted D2D performed much better than traditional D2D link/Numerical results of OP produced on the given values, SNR=20dB, M=4 & $\gamma_{th} = 0\text{dB}$, also assumed the Tx power of D2D link under both cases $P_{nT}^{\text{relay}} = 2/3 P_{nT}^{\text{traditional}}$	The higher number of antennae can cause more interference effect	[125]
Raise the issue of CSI D2D link when devices are unaware of other devices	Modeled the TIM problem and simplified it by the semidefinite algorithm and overcome TIM matrix design with hard constraints	Provided solution matrix rank reduction significantly outclass the traditional schemes and minimize signal interference. Simulation results provided 0.8s to be an acceptable time to run the proposed algorithm & reduce the rank	The use of cluster to tackle larger networks with more scalabilities would be an exciting prospective work	[126]
Cooperative D2D with relay assistance underlay D2D	An AAF relay in cooperative D2D link with maximum ratio combining (MRC)	D2D link throughput increased by 20%, BER decreased by 9dB at low SNR level and when D2D = 20 pairs OP reduced to 0.002	The introduction of full-scale MIMO in the cooperative D2D system would be a future work	[127]
Analyzed the problems in assigning mobile user resources to D2D pairs	A two-phase combinatorial method was rendered to reduce interferences and achieve minimum target sum-rate	Results demonstrated that when interferences are uniform algorithm takes polynomial time lapse	Extend empirical work for non-uniform interference case	[128]
Under mm-wave transmission, evaluate interference problem in the co-existence of D2D & small cells	A Stackelberg game-based interference control process with full frequency reuse underlay mm-wave D2D small cell network	Managed to alleviate interference of mm-wave (at 28 GHz) D2D small cell network and gained trade-off of transmission channel performance/ Numerical values plotted graph showed that with given parameters Tx power CUs= 20dBm and each D2D pair= 23dBm proposed mechanics keep SINR at a high level even in full frequency reuse & gained high throughput performance	Frequency division in the maximum sum-rate assignment (MSRA) could not take benefit of mm-wave BW and throughput is low & growth trend low too	[129]
Subject to maximum power and SINR limitations, a multi-cell joint problem studied	Multi-cell joint power control (MCJPC) and single-cell independent power control (SCIPC) algorithms were presented for efficient power use	Achieved high EE along with good scalability by planted techniques and performed better than other algorithms	The marginal performance degeneration of SCIPC due to less coordination overhead between cells	[130]

TABLE 4. (Continued.) Summary of research work of D2D in literature.

Inspected the coverage probability in the D2D system	A Poisson cluster model for the location of devices under the Nakagami-m fading channel between D2D links	Concluded with stochastic geometry tool numerical results confirmed that coverage probability based on the average count of simultaneous active D2D Tx _s with $m=2$, $\alpha=4$ (for different σ & β values, and different λ and β values respectively) decrease in coverage probability also reduce the link quality	The rise in threshold reduces the coverage	[131]
Performed interference analysis for V2V link at mm-wave band	A closed-form expression of packet error probability (PEP) and ergodic capacity derived	Diversity analysis validated that PEP depends on multipath clusters and more multipath and latency in packet more susceptible to interferences	Integration of sub-6 GHz and mm-wave for robust vehicular communication	[132]
Management of interference in D2D communication within multi-tier cellular HetNet	Three communication modes, i.e., D2D, small cell, and macrocell was delineated to manage interference	The proposed interference scheme effectively mitigated unwanted signals among transmission links and supported good QoS	The mobility of D2D users are not considered in the designed scenario	[133]
Examine the effectiveness of augmenting D2D	Power & time splitting techniques of simultaneous wireless information and power transfer (SWIPT) assessed for two cases: 1) single-tier underlay D2D system and 2) D2D architect underlay HetNet (pico cell & macro cell) system	1) Designed algorithm outperformed the current method based on energy harvested by the CUEs and EE of D2D-tier 2) Power allocated to D2D users in the TS-SWIPT is always less than PS-SWIPT and resulted in less EE; From observation inherent nature of SWIPT can be applied to transform interference in a productive form of harvested energy	Interferences in underlay D2D in HetNet with shared spectrum resources are more strong than traditional HetNet	[134]
Identified and mitigate the cross-tier interference issue for underlay D2D users in HetNet with imperfect CSI in a shared spectrum	Fractional Programming (FP) is implemented to find optimal power for macro-D2D pair (MD), Cross-tier D2D pair (CD), small cell cellular UE (SUE)	The proposed solution suggested that achievable rate for MD & CD decreases with increase in SINR threshold at the MBS and reduces CD, MD anticipated rate with increase in CSI error; greater system performance by creating an appropriate distance between CD and SUE considered	The shorter distance between CD and SUE can cause higher interference	[135]
Focused on improving SE in D2D based HetNet in the presence of ICI	Presented a heuristic resource allocation (RA) algorithm D2D-eICIC based on traffic load	Provide enhanced SE as compared to other interference management schemes/Empirical results showed proposed method performed better when the rate at relay channel was high; whereas at low SINR at relay technique managed to attain better sum-rate than that of eICIC without D2D communications in moderate traffic load of 50%	An efficient method for relay selection to increase the rate of the relay channel left a future work	[136]

consumption, and greater scalability [141]. In comparison, IoT has many critical applications, for instance, industrial automation, smart vehicular system (autonomous vehicles), advanced traffic control system, the remote clinical system for monitoring and operation, massive aeronautical communication system updates, and so on required high reliability, security, safety, dedicated end to end connection with ultra-reliable lower latency for stringent setups and minimal vulnerability to end-users. Because in case of short delay or any failure in transmission would result in devastating consequences. Additionally, researchers have some other constraints; for instance, high energy emission degrades the environmental atmosphere. Therefore, the manufacturing labs should perform the proper assessment of radio various devices' transmission power to avoid severe health and global warming issues.

Moreover, by deploying HetNet infrastructure in the multi-tier 5G radio network, IoT systems may achieve high-quality connectivity and services over a sizeable geographical land with economic feasibility (Fig. 13). In 5G HetNet IoT, a massive number of devices are connected via wireless links [142]. The predecessor mobile technology 4G

notably fostered mobile services and delivered quality IoT device internet services. In the early era, 4G showed far better results than competing technologies, such as WiMAX, BLE, and so on, despite the 5G and beyond is expected to solve the future challenges and shortcomings of 4G and current 5G technology. According to the researchers, effective utilization of both LTE-A and 5G technologies will reduce the inadequacies of new connectivity of wireless interfaces for IoT applications [143]. The current 5G network structure is largely based on the 4G cellular interconnected system's foundation. Also, it has the potential to furnish ultra-reliable and massive connectivity to IoT devices. It is expected to deliver the user with transmission speed up to a maximum of 10 Gbps, whereas 4G only supports up to 1Gbps. However, IoT devices are susceptible and unable to tolerate the high power of interfering signals.

1) INTERFERENCES IN IoT

In the next-generation co-tier and cross-tier HetNet IoT network, the interferences are unavoidable. The unlicensed ISM band is used for IoT services to provide several physical devices to properly tap the spectrum to adhere to short-range

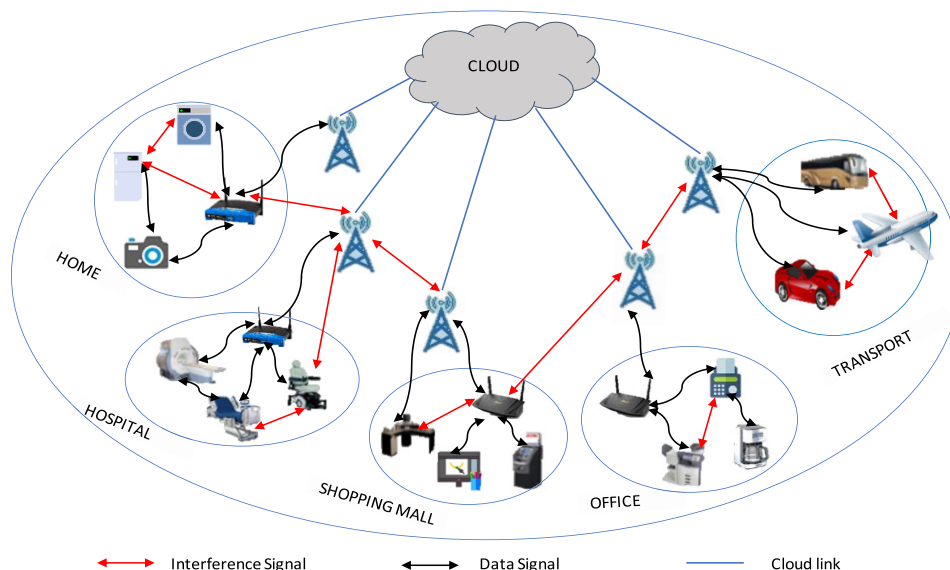

FIGURE 13. Multi-tier 5G IoT network.

radio communication conditions and regulations properly. Hence, the simultaneous usage of a free license frequency band of smart wireless instruments undergoes interference constraints [144]. These interferences are harmful to the effective communication and operation of several uncoordinated devices. In IoT, it is critical to characterize the interference as the devices are of different design and specifications, and not every gadget is coordinated. Some of the recent related work on interference issues are demonstrated in the following.

2) RESEARCH WORK OF IoT IN LITERATURE

In [145], the authors discussed interference management and capacity enhancement of two-tier IoT networks. The sole purpose of their investigation is to control the cognitive interference effect on the macro cell besides maintaining the femtocell's optimal capacity. Two novel schemes have been proposed to remove the interference effect. i.e., interference nulling based cognitive IA and partial mental IA scheme. Consequently, numerical results described that suggested methods improve the small cell capacity without deteriorating performance to the primary users. Besides energy efficiency and interference limitations in the novel network design, another threatening concern is security. Simultaneous transmission of data signals in close-range leak information into another useful signal. The leakage of data results in the loss of critical and highly secure communication as well as privacy.

According to the researcher, it is an immediate concern in the real-world scenario; therefore, in [146], the authors presented a covert wireless communication that prevents the user's information to expose in front of the opponent users. A new method was developed in which a transmitter Alice communicates with a receiver Bob covertly by

avoiding Warden Willie. The results conclude that Willie's unpredictability at the background noise and increase in interference favors Alice's security by considering noise. Moreover, researchers investigate the experimental validation for interference statistics in IoT in a particular area. In [147], the authors performed statistical analysis on unlicensed 863 MHz to 870 MHz frequency bands in different locations in Aalborg, Denmark. As a result, data measured at five other sites and confirmed the heavy-tailed nature of interference in IoT communications. Whereas in [148] authors examined wireless power transmission (WPT) aided by an unmanned aerial vehicle (UAV) in the context of the IoT. The examiner considered interference mitigation of both WP-IoT and UAV dynamic charging policy. Numerical results described that the proposed method effectively curtail the loss of data packets and enhances energy efficiency besides mitigating the network's interference. Also, the proposed technique performed much better than benchmark schemes. On the other hand, a proliferation in data rate is observed in D2D communication when the interference process is fixed in urban IoT applications by introducing a smart context-aware cognitive transmission strategy where D2D and LTE communication uses the same channel resources [149]. In [150], the authors eliminated NB-IoT interference in the LTE network. The researchers presented a probabilistic framework, and numerical results validate that the recommended algorithm outclasses the conventional counterparts in spectrum efficiency, computational complexity, and estimation accuracy. Also, the UEs and BS in LTE systems safeguarded from NB-IoT interference.

In recent research, the guard band concept was introduced in [151], where authors discussed the interference in the coexistence of LTE UEs and several IoT terminals to a single LTE BS in multiple access uplink. In the co-occurrence and

multiple access scenarios, the high-power LTE BS signal interferes with the IoT receiver. To reduce the interference, LTE offered the guard bands method in IoT. As a result, the guard bands are not stringent to minimize the strong interference in IoT receivers from the LTE signal. Hence system performance is compromised. Similarly, in [152], the authors analyze the guard band's interferences in the NB-IoT system's co-existence and the LTE network. Results conclude that the LTE uplink signal with 15 kHz SCS interferes with the NB-IoT uplink signal with 3.75 kHz SCS. In [153] authors suggested various models such as SIR, LIBA, and an epidemic for interference diffusion. The simulation yield infected and susceptible node congregates to zero, while in each diffusion, the number of replaced nodes converges to the total number of underlying diffusion sets. In [154], the authors proposed an Interference Management (IM) scheme called interference steering (IS) in IoT. The results proved that IS outperformed all other existing IM techniques in the context of spectral efficiency. Besides, an ICI problem that IoT terminals received is discussed in [155]. A relay-assisted communication approach in which a relay selection algorithm is designed helps expand device throughput besides spectrum resources availability. The novel scheme assists in delivering optimum signals in the positively ICI-affected area. By applying the suggested scheme, results described that a substantial number of IoT nodes that served simultaneously increases up to 17.07%. At the same time, system throughput reached up to 43.96%. The interference characteristics are changed in 3D environments in comparison with the existing terrestrial IoT systems. Research on aerial IoT devices was conducted based on an analysis and the mitigation of interference [156]. A cross-dipole antenna setting at the transmitter, either on the z or y-axis, depends on the receiver setting offered. Also, a 3D topology channel model centered on the device location was created. The results outcome explained that the cross-dipole antenna method outperforms the process that uses only the z-dipole antenna.

Due to UEs' extensive growth, the management and support of high data rates in a mass transit system is also critical. Consequently, in [157], the authors demonstrated the mIoT-small cell network's deployment in the metropolitan city bus system. The investigators raised the concern of the dynamic interference problem that makes the resource allocation challengeable in mIoT-mSC. It severely affects the coverage area and capacity of a cellular network. The authors offered LSTM networks that forecast city bus location and then identify interference patterns between mSCs within a road section. It also dispensed the Threshold Percentage Dependent Interference Graph (TPDIG) algorithm for city buses mounted with mSCs. Moreover, a comparative analysis of resource allocation using TPDIG, TIDIG, and GPSDIG is provided based on interference; the results advised that to avoid the interference's deterministic behavior, interference percentage is used over time-based. In [158], authors studied the architect of iterative receiver for the SU system that

effectively manages the multi-interference with limited knowledge of the PU system in the CSA model. The affinity propagation (AP) algorithm idea was presented to comprehend the clustering module. Consequently, the AP algorithm delivers more excellent performance in the clustering of multi-interference signals compared to other algorithms. Due to the enormous connectivity of IoT devices and simultaneous communication, interference problem limits the potential of link connectivity and resources. Therefore, researchers addressed the interference mitigation procedure by considering the 3D antenna radiation pattern of the dipole antenna [159]. Additionally, an antenna selection method is furnished to decide a suitable antenna pattern at the transmitter. The simulation results authenticate that the recommended scheme delivers high performance in scenarios such as ground to air and air to air. In particular, when IoT devices are well-distributed in the surface and spatial domain besides the height of aerial equipment is higher.

Table 5 shows the summary of the research work of IoT in the literature discussed in this section.

V. PROPOSED METHODOLOGIES BY 3GPP

This review article discussed several recent works on interference mitigation and numerous new techniques that are in progress on interference removal. Additionally, research communities, universities, related industries, and main standardization bodies work together to deliver the future network demand by overcoming the various wireless cellular network obstacles. The 3GPP groups have become the principal standard development authority for cellular systems and are continually evolving through mobile generations. Considering the 5G and beyond HetNet system, 3GPP recently contributed various methods and procedures to mitigate different types of interferences under development for next-generation mobile communication.

A. PILOT CONTAMINATION

The orthogonal uplink pilot signal supports the user to guess the channel in the same cell. For efficient resource management, the same pilot sequence could be reused by the neighboring cell user. The frequency reuse has shown great strength for the efficient use of the available spectrum band; nonetheless, it is severely affected by the inevitable CCI [160]. Since massive multiple-input-multiple-output (M-MIMO) is one of the 5G multi-cell network's main enabling technology. In M-MIMO TDD mode, the pilot symbols are highly exposed to contamination due to the reuse of resources and introduce ICI. The interference effect in a signal decreases the achievable rates and overall efficiency of the spectrum. Extensive literature work dedicated to eliminating ICI with a primary focus on reducing pilot symbol contamination in channel estimation.

These techniques have helped reduce the bit error rate (BER) issue and enhance a spectrum's efficiency. Earlier, most of the researchers believed and considered non-orthogonal signals as the only source of pilot issues.

TABLE 5. Summary of research work of IoT in literature.

Problem/Issue	Methodology	Outcome/Advantages	Limitation/Future Work	References
To improve capacity and manage cross-tier interference of two-tier IoT HetNet	Interference nulling based cognitive interference alignment (IA) schemes for co-tier & cross-tier interferences of femtocell with negligible noise	Numerical results validated by graph and showed as antenna streams 5 and 7 just satisfied the feasibility state and maximum interference level was < 3% and did not affect the operation of the proposed method	The research is completely based on physical layer aspects. In the future, use the same resources to investigate the network layer	[145]
Advanced highly secure data transfer over IoT system	A new method was developed in which a transmitter Alice communicates with a receiver Bob covertly by avoiding the Warden Willie	Experimental effects justified that hiding information in interference (introduce as a noise source) increase the security level	The complexity of the algorithm is high	[146]
Performed an experimental validation on the characterization of interference	Heavy tailed distribution model with two subclasses a) Fat-tailed distributions and b) Subexponential tail decay	The measurement obtained from 5 different locations and validated the heavy-tailed nature of the interference power distribution/Hill plots showed that at, $\theta = 0.4$ confirmed tail indices of data agree much better with heavy tail models than exponential scheme	Need to design of channel access strategies depending on user locations to limit the impact of interference	[147]
Examined the power level of limited energy devices to improve EE in IoT	Designed novel UAV aided WPT-IoT network with consideration of both interference minimization of WP-IoT and charging policy of the UAV besides MFG power control algorithm	Average SE and network efficiency significantly enhanced in comparison to benchmark models	Higher IoT devices degraded the overall network performance	[133]
To support data and computational process in urban IoT system	Context-aware cognitive transmission policy with interference control for hybrid LTE and D2D radio networks to support urban IoT applications	Achieved significant throughput rate of the D2D channel when interference process is fixed during complete video transmission	Consider more articulated cases such as sophisticated computer vision algorithms and smart HARQ techniques to improve real-time services	[149]
Elimination of interference in NB-IoT in LTE-A	Novel sparse machine learning-based probabilistic framework of narrow-band interference (NBI) recovery with enhanced RSCEM model proposed to improve convergence rate and accuracy	Verification from theoretical and numerical values confirmed that the new algorithm at the target BER of 10^{-4} comprehensively outperforms the state-of-the-art counterparts based on SE, estimation accuracy & complexity in operation. Also, the graph curves showed only a 0.2 dB difference between the presented & ideal (without NBI) case	NB-IoT antenna designing tradeoff the EE	[150]
Feasibility of co-existence of LTE-A & IoT UEs in UL mode in interference-limited network	IoT single tone model with 3.75 kHz SCS with compromising a slight implementation difficulty	The addition of guard bands at the edges of IoT RB didn't satisfy the isolation level and QoS compromised. However, IoT receive is strong to CFO level below 0.1 and I/Q imbalance didn't introduce a noticeable drop in the performance	The interference effect is higher for more IoT devices	[151]
Analyzed the interferences of guard band NB-IoT system in the coexistence of LTE system	Proposed an uplink scheduling method for LTE (15 kHz) system to enhance the effectiveness of guard band NB-IoT (3.75 kHz) system	Although LTE signal interfere with NB-IoT, results of graph 6 (showed frequency domain data received by NB-IoT Rx) & 7 (showed the constellation received by NB-IoT Rx) contemplated that use of guard-RB reduces interference of the LTE system on the NB-IoT system	Current work limited on the coexistence of NB-IoT and LTE networks and more simulation in a diverse scenario required to compare the reception quality	[152]
The stability of the system evaluated in an interference environment	The SIR model, epidemic model to assist in the diffusion of interference when collecting tree protocols, i.e., LIBA employed	Proposed techniques achieved highly effective results and simulation test confirmed that both vulnerable and infected terminals converge to zero	SIR decreases with the complexity of the algorithm	[153]
Investigate the stronger interference suppression in IoT	Proposed IS a technique to manage intrusions in IoT	IS significantly increased SE as compared to other existing interference management models	Symmetrical interference topology designed and how to suppress negative effect is beneficial for further exploration	[154]

TABLE 5. (Continued.) Summary of research work of IoT in literature.

ICI problem in IoT in 5G HetNets	A relay-assisted communication approach with interference avoidance presented	The proposed algorithm showed that the number of simultaneously served IoT terminals and total network throughput increased up to 17.07% and 43.96%, respectively, besides average Tx energy of IoT terminals consumed during each TTI reduced by 44.15%	Need to develop a model that utilizes multi-hop relaying to support reliable connectivity and more IoT nodes simultaneously	[155]
Research conducted on the analysis of interference characteristics in a 3D environment	A 3D topology IoT networks with the amalgamation of aerial & terrestrial links	Cross dipole antenna model delivered superior results than the schemes that only used z-dipole antenna and performance can be increased by improving the height of aerial receivers/ simulation analysis showed the ergodic sum-rate based on the number of aerial receivers in the network (at varying height) as 50% / 30% / 10% of aerial receivers is a peak in low/medium/high height of aerial receivers	Must design a z-dipole antenna with lower computational cost	[156]
Mobile IoT (mIoT)-small cell network in the vehicular system for efficient resource allocation considered	TPDIG algorithm for city buses mounted with mSC dispensed; long-short term memory (LSTM) based neural networks designed to estimate city buses location for interference determination between mSCs plus greedy graph coloring algorithm utilized to allocate resources to TPDIG	TIDIG achieved a data rate of 22.5% and is slightly better than TPDIG algorithm. An average degradation of 3.38% in achievable throughput of GPSDIG based resource allocation scheme	Generate the realistic data set to improve results further and the suggested algorithm will be applied to more diverse applications such as vans, school buses, uber, etc.	[157]
Studied the design of iterative receiver for SU system in a multi-interference scenario	The clustering module by utilizing the AP algorithm	AP scheme delivered much better performance than other algorithms in clustering multi-interference signals	Clustering network cause higher interference effect	[158]
Examined an uncoordinated IoT network in a 3D topology scenario	Proposed interference mitigation technique based on the 3D radiation pattern of dipole antennas (number of dipole antenna 2 or 3), also antenna selection methods to decide the best pattern at Tx	Simulation test verified the optimum results in ground-to-air and air-to-air cases when IoT devices are well-distributed in the ground and air and when the altitude of aerial devices is high	Need to design an algorithm that includes external noise effect from air	[159]

Other sources of pilot intrusions have recently been recognized, for instance, hardware impairments distortion. Subsequently, a non-reciprocal transceiver is highly vulnerable to interference because of the RF chain's internal clock design [161]. Also, the pilot symbol interference coordination in in-band FD (IBFD) M-MIMO networks is assumed to be complex due to pilot reuse factor 1 and resulted in SI. Thus, a robust algorithm is required to completely mitigate pilot contamination in IBFD M-MIMO systems [162].

B. UNMANNED AERIAL VEHICLES

Cellular-connected UAVs will play an important role in 5G and beyond. The 3GPP standardization shows a keen interest in UAVs for future wireless communication deployment. Currently, the 3GPP member's community practice various designs and protocols for UAVs' proper deployment in the coming practical scenario. The promising feature of cellular-based UAVs is that it allowed large coverage area spatially that delivers real-time video surveillance anytime and anywhere. Nevertheless, frequency reuse is essential due to the scarcity of resources, and sharing the spectrum between UAVs and UEs induces ICI and downgrades the system performance [163].

Various interference minimization schemes have been developed for the collaborative operation of cellular users and aerial vehicles scenario. Such as [164] the researchers analyzed and understood the performance of M-MIMO, 3D beamforming, closed-loop power control in the presence of UAVs in mobile networks. Likewise, in articles [165], [166], multi-beam UAV for cellular uplink and aerial-ground ICIC design for UAV uplink signal proposed respectively to more effectively eliminate the strong interferences. In contrast, a cooperative NOMA technique has been presented further to enhance the ICIC design performance in [167]. However, none of the work was performed on the cellular downlink transmission interference issues with aerial machines.

C. BS IDENTIFICATION

The coordination of all MBSs and the users associated with them is essential to avoid ICI. The mutual coordination of all MBSs with their neighboring cells via the backhaul X2 interface was presented. However, the identification and transmission of interferer BSs over the air are critical, though the reference signal's advancement and variation in low transmission power can easily avoid the interference problem [168]. In dense mmWave networks, a study has been conducted

to avoid inter-BS interference by choosing a downstream transmission coordination scheme and decision made on the schedule of packet delivery based on SINR level [169]. Few authors discussed the inter-BS beam coordination process to increase the network capacity by providing coordination algorithms among the several BSs [170]. In contrast, spectrum pooling has been investigated by using a centralized beam coordination technique [171]. Although these algorithms have helped to transfer channel information efficiently, the framework's viability extensively relies on the latency of the information exchanged and more work needed to assess the practical effects.

D. CONTROL CHANNEL

Control channels are part of uplink and downlink data transmission. It carries controlling information of the UEs; for instance, the physical uplink control channel (PUCCH) conveys information about CQI, ACK/NAK, and the HARQ mechanism. The control channels play an integral role in channel estimation, signal synchronization, cell searching, and so on. However, the separation between these uplink and downlink control channels is crucial to avoid. Thus, 3GPP proposed that MBS's power intensity should be less than the given threshold power and significantly minimize the interference changes [172].

Many studies have recently been devoted to the data and control channel interferences when small cells are deployed in a macro cell overlay mode network [173], [174]. In the control channel context, many of these researches have identified coverage hole's existence when femtocells are configured in a macro-cell overlay wireless network. To reduce the effect of control channel interferences, 3GPP suggested that femtocells should be operated in only closed access mode, i.e., each femtocell construct and maintain UEs list that is permissible to access the services [175].

E. RECEIVER DESIGN

To suppress the inter-user and intra-cell interferences at the user terminal, the 3GPP proposed the technique called Code Word Level Interference Cancellation (CW-IC). The standard development authority further added that ICI could also be minimized with Minimum Mean Square Error-Interference Rejection Combining (MMSE-IRC) in an ultra-dense multiple small cell network methodologies [176]. Much of research work has lately been conducted on the user-terminal interference avoidance in multi-user FD MIMO systems. It has been primarily focused on the mitigation of inter-user interference by proposing Eigen-BF [177] and non-linear processing [178] to attain maximum transmission rate. Nevertheless, both techniques have extremely relied on the eigenmode of the channel, and terminal antenna element spacing also significantly impacts the performance of the transmission.

F. CELLULAR-V2X

The 3GPP introduced two modes, i.e., BS scheduled and direct scheduled in release 14 of the LTE standards

for cellular-vehicular-to-everything (C-V2X) communication [179]. In fast-moving vehicles, mobility management and channel estimation are two potential issues for better vehicular communication performance. However, the proposed technique helped to reduce Doppler shifts by increasing the number of demodulation reference symbols per frame. Besides, rising in demodulation of the reference signal sequence randomization for heavy interference reduces high vehicular density [180]. 3GPP's C-V2X also specified protocols for short-range vehicle-to-vehicle (V2V) communications PC5 [181]. In this regard, an air interface called sidelink/PC5 was utilized for direct contact between vehicles. Along with wide-area vehicle-to-network (V2N) communication (allows automobiles to communicate with BS). In an Intelligent transportation system (ITS), end-to-end transmission latency and viability are exposed in V2X technologies and the safety of traffic and bandwidth efficiency of applications is suffered to react to environmental changes [182].

G. NARROW BEAM LINK ACQUISITION

The large antenna arrays and mm-wave transmission increases the importance of narrow and focused beams. The mm-wave transmission is highly directional and sensitive to the misalignment of beams. Therefore, the researchers and standardization industries flourished new approaches such as Beamforming and Beamsteering [183]. The proposed techniques helped avoid the interference phenomenon in the massive MIMO system and provide dedicated narrow beams to each user yet regular large multiple beams from the antennas produce IBI. Also, narrow beams are highly vulnerable in establishing a connection between D2D users and MBSs, particularly in high mobility. To mitigate the IBI issue and reduce sidelobe level amplitude tapering method has been investigated [184]. Some investigators advised that standard forms of zero-forcing can also provide excellent results in suppressing interference in the desired direction [185], [186]. But both are dependent on the adjustment of amplitude excitation level over the antennas for proper beam formation.

Table 6 shows the summary of the proposed methodologies by 3GPP discussed in this section.

VI. FUTURE RESEARCH WORK

The parallel operation of HetNet, RN, D2D, and IoT technologies in the current 5G wireless communication network improves the system's functioning and makes future technologies more concrete and reliable. It also enhances the user's experience and efficiency of the cellular network effectively. The future challenges of the discussed topics are summarized below.

A. HETEROGENEOUS NETWORK

In mm-wave enabled HetNet system of 5G and beyond, maintaining the link quality is a crucial challenge, especially with the vehicular user. Because the mm-wave are highly susceptible to blockages of the natural and environmental sources or any other moving heavy vehicles, in cellular

TABLE 6. Summary of proposed methodologies by 3GPP.

Challenges	Mitigation Methodology	Limitation
Pilot contamination	Pilot sequence division in chain network [160], large scale fading precoding [161], and zero-forcing (ZF) precoding [162]	Non-ideal transceiver hardware and transceiver impairment in multi-user multi-cell, non-reciprocal transceiver, pilot sequence in-band FD M-MIMO
Unmanned aerial vehicles	Echo state network [163], power control and coverage extension for uplink (UL)-downlink (DL) and impact of UL interference [164], multi-beam UAV UL [165], ICIC design UAV UL [166], cooperative NOMA [167]	Downstream interference issues in different scenarios of cellular users and UAVs
BS identification	Interference avoidance [168], DL coordination scheme [169], pencil beam formation [170], Spectrum pooling coordination [171]	Latency, regular packet loss, and real-world implementation effect
Control channel	Power intensity [172], cross-carrier scheduling and abs [173], dynamic resource partitioning [174], sparse and downlink power control [175]	Coverage holes, reliability in dynamic nature of HeNBs, UEs channel estimation side effects, Seamless coordination in HeNB, and Joint optimization of control and data channels
Receiver design	CW-IC [176], Eigen-BF [177], non-linear processing [178]	Eigen mode of the channel and antenna element spacing
C-V2X	BS schedule and autonomous schedule [179], truck platooning [180], for V2V sidelink/PC5 [181, 182]	Incompetent in an ultra-dense vehicular environment, high latency, ultra-high reliability, consistent collision, practical commercial deployment probability
Narrow beam link acquisition	Hybrid beam synthesis [183], amplitude tapering [184], ZF hybrid BF [185, 186]	IBI in wide-scale antenna elements and amplitude excitation level

communication, transmission orthogonality of sub-carriers can be lost when movement multipath is present. Therefore, many investigations have been performed to mitigate vehicular cellular user interferences. For instance, in [187], the authors presented a unique idea for the mm-wave signal reliability and overall delay problem by deploying machine learning algorithms to predict blockage efficiently and delivers handoff to adjacent BS without interrupting the connection. The simulation results proved that the proposed method provides optimum results. However, the technique was developed for a single user and could be challenging for multi-user systems. Similarly, due to the simultaneous transmission of licensed and unlicensed spectrum users, the BS performs continuous, seamless switching. The multiple switching between different technologies regularly introduces interference, fading, and SNR problems.

To minimize the issue, a feed-forward neural network technique was implemented for system reliability and seamless coverage [188]. In [189], the authors proposed a collusion-resistant spectrum auction-based KNN algorithm for interference avoidance to implement a dynamic spectrum allocation technique. The simulation results show that the suggested algorithm effectively solved the problem and highly recommendable for implementation. Moreover, an essential feature of the 5G and beyond network is NFV. The 5G cellular system uses it to create a more flexible environment by partitioning the network function from its hardware components. Nonetheless, the virtualized network of NFV causes unauthorized intrusion or data leakage [190]. It is a severe security threat, and to furnish secure processing of every data, a suitable machine learning mechanism is highly desirable. Similarly, in [191], the authors presented an approach to enhance system global energy efficiency (GEE)

by using the computationally effective algorithm in the presence of multi-carrier interference in the HetNet system. The framework consists of fractional programming, game theory, and learning tools to handle GEE's limitations. The numerical test proven that imposing minimum rate constraints reduce the GEE performance, however, it completely supports the minimum rate for communication for all users in a multi-cell network.

B. RELAY NODE

In conventional railway systems, they are still using previous cellular technologies that are undesirable for future demand of data rate and QoS. Therefore, an advancement in the railway structure and new technologies leads to smart train networks. Modern railway networks are required to meet the upcoming demand of higher throughput users, massive connectivity of various wireless devices, scalability, and reliability. An RN deployment in railways would be smart for future moving platform scenarios [192]. Therefore, an FD RN in trains or mass communication systems in urban and rural areas is exciting for the researchers. However, the fast-moving platform creates a blockage, continuous disconnection, multipath and multi-user interferences, and other pertinent issues. A robust scheme is demandable. In [193], the authors proposed an ML(Machine Learning) based selection technique in hybrid multi-hop networks that adaptively choose each relay's forwarding technique. The minimum transmit power for all transmitting nodes has been derived, and the method is considered appropriate for the ultra-dense network. Hence, the suggested algorithm provides excellent results, but the node's location and relay residual power are key selection factors and any small error will create chaos in the network. Additionally, an algorithm avoided the high FD

transmission complexity which is a major concern for future interference-oriented networks.

C. DEVICE-TO-DEVICE

In D2D, a new interference management method is required for directional interference in the current mm-wave 5G network for multiple D2D links. Besides, 5G multi-tier HetNet with D2D communication, management of interferences, and resource allocation problems for underlay shared spectrum with cellular users are more challenging than existing methods. The management and mitigation of interferences among low-power wireless sensors, small cells, and macro-cell mobile links, and D2D links are still challenging and have space for further enhancement. Because, level and conditions of interferences are different in different tiers of HetNet due to several access limitations (such as public, transport, private, and so on) [194]. Privacy and authentication are essential concerns in self-governing D2D communication. A lot of critical information shared over cellular networks could be corrupted, hacked, or misplaced. Therefore, this is still an open topic for future concerns. D2D communication is considered a coordinated reception and transmission of various devices, and a moving object creates instability in the D2D link. Hence an agile scheme that maintains network stability with high profile security is essential. Also, a robust method is demandable for D2D communication where cellular network coverage is unavailable. In [195], authors discussed various D2D enabled threats in the HetNet system, for instance, resource scheduling, power and interference management, spectral efficiency, and so on. The Distributed Artificial Intelligence Solution (DAIS) algorithm was proposed, and simulation results proved that the suggested method delivers low computational work and greater spectrum efficiency. For future improvement, the researchers considered implementing the same Belief-Desire-Intention (BDI) intelligent agents with extended capabilities (BDIx) framework with a more robust AI scheme to evaluate system performance in a more complex environment by introducing mobile UEs. Besides advancing stochastic geometry-based methods, they are required to create a more uncertain environment for the downlink and uplink coverage and low power consumption for UAVs, D2D, and cellular UEs enabled HetNet system [196].

D. INTERNET OF THINGS

An advanced and intelligent 5G IoT network is essential that can process a high volume of data with less power consumption, lower latency, and good connection reliability among various devices as billions of devices are inter-linked and a large amount of traffic using by all connected gadgets via the Internet. Hence, a stringent management scheme in IoT to handle enormous automated equipment is needed [197]. In such a challenging context, Digital Annealer (DA), a quantum-inspired technology applying the concept of simulated annealing for combinatorial optimization problems, would be a promising solution [198]. By solving

fully connected Quadratic Unconstrained Binary Optimization (QUBO) problems much faster than classical computing, DA can realize various potential service-oriented applications for the customized service-oriented optimization problems, including enhancing smart mobility services with high QoS, realizing virtualization and softwarization for smart cities with lower energy consumption, and enabling various Real-time services which provide information to the users instantly. In this way, DA enables various IoT-based applications with optimal efficiency to realize potentially unexplored future network services.

Besides, some other aspects where research is immensely required are storage capacity for Bigdata, coming from various IoT sources, and security. Typically, due to the massive exchange of data between nodes with the help of co-existence technologies, security is one major concern for future communication that protects user data and other applications from various other devices' illegal involvement. To improve the maximum coupling, coverage enhancement is critical to hold effectively tactile internet and multimedia applications. Similarly, backup security is also required for high-level user data safety and to avoid any intrusion from hackers [199]. Current supervised and unsupervised ML techniques are significantly exposed to detect the attacks due to oversampling and insufficient training data. Therefore, a backup security solution with the ML method is demandable to provide secure IoT connections. Another future concern in IoT is a more concrete system required for nodes to perform underlay different operating situations with a decrease in energy while maximizing network and cloud systems [200]. The Time of Flight (ToF) imaging approach is exclusively using in a practical world that provides depth maps in real-time. Most of the work performed on hardware modification and complex algorithms is costly to rectify the problem. In [201], the authors presented an encoder-decoder neural network technique, which significantly reduces the reflectance and provides good results for the real world scenario. Nonetheless, the suggested method failed to cancel the Message Passing Interface (MPI) when objects are very close to the camera.

VII. CONCLUSION

For next-generation communication, it is expected that billions of devices communicating with each other require higher throughput while maintaining the spectrum frequency and QoS for each user. Due to the proliferation of data demand and the rapid growth in the numbers of users and electronic devices directed towards the ultra-dense communication network, the 5G and beyond network can also be termed as a multi-tier HetNet cellular network. Consequently, the network performance from the simultaneous operation of multi-small cells within a multi-tier network is heavily degraded with various interferences. We then investigated the interference in the multi-tier HetNet cellular network. Furthermore, this study broadly discussed several types of interferences classified according to their deployment and propagation characteristics, such as co- and cross-tier

interferences in HetNet and homogeneous and control channel interferences in HetNet architecture. Similarly, the survey addressed the issues of interference in D2D and IoT communication by considering different scenarios. Additionally, the concept of RN and the classification of interferences that downgrade the RN operation and network performance and user data experience have been demonstrated thoroughly. These sections are presented with relevant state-of-the-art research studies on interference mitigation, cancellation, and avoidance technique, with analyses of methodologies proposed by 3GPP.

In conclusion, this comprehensive review article presented and discussed numerous state-of-the-art researches as well as detailed potential future research directions regarding interference issue management in 5G. It is expected that this article can act as a feasible and practical evolutionary source for the designing of the 5G and beyond together with the future 6G network. However, this review is not highlighting the studies related to various interference approaches and issues with respect to big data, machine learning, artificial intelligence in the 5G and beyond network.

REFERENCES

- [1] F. Qamar, M. U. A. Siddiqui, M. N. Hindia, R. Hassan, and Q. N. Nguyen, "Issues, challenges, and research trends in spectrum management: A comprehensive overview and new vision for designing 6G networks," *Electronics*, vol. 9, no. 9, p. 1416, Sep. 2020.
- [2] F. Qamar, "Enhancing QoS performance of the 5G network by characterizing mm-wave channel and optimizing interference cancellation scheme," Univ. Malaya, Kuala Lumpur, Malaysia, Tech. Rep., 2019.
- [3] A. Gupta and R. K. Jha, "A survey of 5G network: Architecture and emerging technologies," *IEEE Access*, vol. 3, pp. 1206–1232, 2015.
- [4] M. Z. Chowdhury, M. Shahjalal, S. Ahmed, and Y. M. Jang, "6G wireless communication systems: Applications, requirements, technologies, challenges, and research directions," *IEEE Open J. Commun. Soc.*, vol. 1, pp. 957–975, 2020.
- [5] C. Safitri, Y. Yamada, S. Baharun, S. Goudarzi, Q. N. Nguyen, K. Yu, and T. Sato, "An intelligent content prefix classification approach for quality of service optimization in information-centric networking," *Future Internet*, vol. 10, no. 4, p. 33, Apr. 2018.
- [6] F. Qamar, M. N. Hindia, T. Abbas, K. B. Dimiyati, and I. S. Amiri, "Investigation of QoS performance evaluation over 5G network for indoor environment at millimeter wave bands," *Int. J. Electron. Telecommun.*, vol. 65, no. 1, pp. 95–101, 2019.
- [7] R. Dilli, "Analysis of 5G wireless systems in FR1 and FR2 frequency bands," in *Proc. 2nd Int. Conf. Innov. Mech. Ind. Appl. (ICIMIA)*, Mar. 2020, pp. 767–772.
- [8] A. L. Swindlehurst, E. Ayanoglu, P. Heydari, and F. Capolino, "Millimeter-wave massive MIMO: The next wireless revolution?" *IEEE Commun. Mag.*, vol. 52, no. 9, pp. 56–62, Sep. 2014.
- [9] R. Q. Hu and Y. Qian, "An energy efficient and spectrum efficient wireless heterogeneous network framework for 5G systems," *IEEE Commun. Mag.*, vol. 52, no. 5, pp. 94–101, May 2014.
- [10] M. N. Hindia, F. Qamar, H. Ojukwu, K. Dimiyati, A. M. Al-Samman, and I. S. Amiri, "On platform to enable the cognitive radio over 5G networks," *Wireless Pers. Commun.*, vol. 113, no. 2, pp. 1241–1262, Jul. 2020.
- [11] T. Abbas, F. Qamar, M. N. Hindia, R. Hassan, I. Ahmed, and M. I. Aslam, "Performance analysis of ad hoc on-demand distance vector routing protocol for MANET," in *Proc. IEEE Student Conf. Res. Develop. (SCORED)*, Sep. 2020, pp. 194–199.
- [12] V. Chandrasekhar, J. Andrews, and A. Gatherer, "Femtocell networks: A survey," *IEEE Commun. Mag.*, vol. 46, no. 9, pp. 59–67, Sep. 2008.
- [13] T. Yang, F. Heliot, and C. H. Foh, "A survey of green scheduling schemes for homogeneous and heterogeneous cellular networks," *IEEE Commun. Mag.*, vol. 53, no. 11, pp. 175–181, Nov. 2015.
- [14] X. Ge, S. Tu, G. Mao, and C. X. Wang, "5G ultra-dense cellular networks," *IEEE Trans. Wireless Commun.*, vol. 23, no. 1, pp. 72–79, Feb. 2016.
- [15] C.-L. I, S. Han, Z. Xu, S. Wang, Q. Sun, and Y. Chen, "New paradigm of 5G wireless Internet," *IEEE J. Sel. Areas Commun.*, vol. 34, no. 3, pp. 474–482, Mar. 2016.
- [16] A. Gachhadar, F. Qamar, D. S. Dong, M. B. Majed, E. Hanafi, and I. S. Amiri, "Traffic offloading in 5G heterogeneous networks using rank based network selection," *J. Eng. Sci. Technol. Rev.*, vol. 12, no. 2, pp. 9–16, 2019.
- [17] F. Qamar, M. H. D. N. Hindia, K. Dimiyati, K. A. Noordin, and I. S. Amiri, "Interference management issues for the future 5G network: A review," *Telecommun. Syst.*, vol. 71, no. 4, pp. 627–643, Aug. 2019.
- [18] P. Pirinen, "A brief overview of 5G research activities," in *Proc. 1st Int. Conf. 5G Ubiquitous Connectivity*, 2014, pp. 17–22.
- [19] M. S. Haroon, Z. H. Abbas, F. Muhammad, and G. Abbas, "Analysis of coverage-oriented small base station deployment in heterogeneous cellular networks," *Phys. Commun.*, vol. 38, Feb. 2020, Art. no. 100908.
- [20] N. Lee and R. W. Heath, Jr., "Degrees of freedom for the two-cell two-hop MIMO interference channel: Interference-free relay transmission and spectrally efficient relaying protocol," *IEEE Trans. Inf. Theory*, vol. 59, no. 5, pp. 2882–2896, May 2013.
- [21] F. Qamar, K. Dimiyati, M. N. Hindia, K. A. Noordin, and I. S. Amiri, "A stochastically geometrical Poisson point process approach for the future 5G D2D enabled cooperative cellular network," *IEEE Access*, vol. 7, pp. 60465–60485, 2019.
- [22] T. Abbas, F. Qamar, I. Ahmed, K. Dimiyati, and M. B. Majed, "Propagation channel characterization for 28 and 73 GHz millimeter-wave 5G frequency band," in *Proc. IEEE 15th Student Conf. Res. Develop. (SCORED)*, Dec. 2017, pp. 297–302.
- [23] M. N. Hindia, F. Qamar, M. B. Majed, T. A. Rahman, and I. S. Amiri, "Enabling remote-control for the power sub-stations over LTE—A networks," *Telecommun. Syst.*, vol. 70, no. 1, pp. 37–53, Jan. 2019.
- [24] F. Qamar, T. Abbas, M. N. Hindia, K. B. Dimiyati, K. A. Bin Noordin, and I. Ahmed, "Characterization of MIMO propagation channel at 15 GHz for the 5G spectrum," in *Proc. IEEE 13th Malaysia Int. Conf. Commun. (MICC)*, Nov. 2017, pp. 265–270.
- [25] F. Qamar, M. H. S. Siddiqui, K. Dimiyati, K. A. B. Noordin, and M. B. Majed, "Channel characterization of 28 and 38 GHz MM-wave frequency band spectrum for the future 5G network," in *Proc. IEEE 15th Student Conf. Res. Develop. (SCORED)*, Dec. 2017, pp. 291–296.
- [26] F. Qamar, M. H. S. Siddiqui, M. N. Hindia, K. Dimiyati, T. A. Rahman, and M. S. A. Talip, "Propagation channel measurement at 38 GHz for 5G mm-wave communication network," in *Proc. IEEE Student Conf. Res. Develop. (SCORED)*, Nov. 2018, pp. 1–6.
- [27] L. Liu, Y. Zhou, V. Garcia, L. Tian, and J. Shi, "Load aware joint CoMP clustering and inter-cell resource scheduling in heterogeneous ultra dense cellular networks," *IEEE Trans. Veh. Technol.*, vol. 67, no. 3, pp. 2741–2755, Mar. 2018.
- [28] M. Rebato, M. Mezzavilla, S. Rangan, F. Boccardi, and M. Zorzi, "Understanding noise and interference regimes in 5G millimeter-wave cellular networks," in *Proc. Eur. Wireless 22nd Eur. Wireless Conf.*, 2016, pp. 1–5.
- [29] J. Liu, M. Sheng, L. Liu, and J. Li, "Interference management in ultra-dense networks: Challenges and approaches," *IEEE Netw.*, vol. 31, no. 6, pp. 70–77, Nov. 2017.
- [30] K. I. Pedersen, Y. Wang, S. Strzyz, and F. Frederiksen, "Enhanced inter-cell interference coordination in co-channel multi-layer LTE-advanced networks," *IEEE Wireless Commun.*, vol. 20, no. 3, pp. 120–127, Jun. 2013.
- [31] S. Deb, P. Monogioudis, J. Miernik, and J. P. Seymour, "Algorithms for enhanced inter-cell interference coordination (eICIC) in LTE HetNets," *IEEE/ACM Trans. Netw.*, vol. 22, no. 1, pp. 137–150, Feb. 2014.
- [32] K. A. B. Noordin, M. N. Hindia, F. Qamar, and K. Dimiyati, "Power allocation scheme using PSO for amplify and forward cooperative relaying network," in *Proc. Sci. Inf. Conf. Cham, Switzerland: Springer*, 2018, pp. 636–647.
- [33] N. Shende, O. Gurbuz, and E. Erkip, "Half-duplex or full-duplex relaying: A capacity analysis under self-interference," in *Proc. 47th Annu. Conf. Inf. Sci. Syst. (CISS)*, Mar. 2013, pp. 1–6.
- [34] V. Aggarwal, M. Duarte, A. Sabharwal, and N. K. Shankaranarayanan, "Full-or half-duplex? A capacity analysis with bounded radio resources," in *Proc. IEEE Inf. Theory Workshop*, Sep. 2012, pp. 207–211.

- [35] D. Kim, S. Park, H. Ju, and D. Hong, "Transmission capacity of full-duplex-based two-way ad hoc networks with ARQ protocol," *IEEE Trans. Veh. Technol.*, vol. 63, no. 7, pp. 3167–3183, Sep. 2014.
- [36] T. Riihonen, S. Werner, and R. Wichman, "Comparison of full-duplex and half-duplex modes with a fixed amplify-and-forward relay," in *Proc. IEEE Wireless Commun. Netw. Conf.*, Apr. 2009, pp. 1–5.
- [37] M. O. Al-Kadri, A. Aijaz, and A. Nallanathan, "Ergodic capacity of interference coordinated hetnet with full-duplex small cells," in *Proc. Eur. Wireless, 21th Eur. Wireless Conf.*, 2015, pp. 1–6.
- [38] G. Zheng, I. Krikidis, J. Li, A. P. Petropulu, and B. Ottersten, "Improving physical layer secrecy using full-duplex jamming receivers," *IEEE Trans. Signal Process.*, vol. 61, no. 20, pp. 4962–4974, Oct. 2013.
- [39] M. N. Hindia, F. Qamar, T. Abbas, K. Dimiyati, M. S. A. Talip, and I. S. Amiri, "Interference cancellation for high-density fifth-generation relaying network using stochastic geometrical approach," *Int. J. Distrib. Sensor Netw.*, vol. 15, no. 7, 2019, Art. no. 1550147719855879.
- [40] F. Qamar, K. B. Dimiyati, M. N. Hindia, K. A. B. Noordin, and A. M. Al-Samman, "A comprehensive review on coordinated multi-point operation for LTE—A," *Comput. Netw.*, vol. 123, pp. 19–37, Aug. 2017.
- [41] M. N. Hindia, F. Qamar, T. A. Rahman, and I. S. Amiri, "A stochastic geometrical approach for full-duplex MIMO relaying model of high-density network," *Ad Hoc Netw.*, vol. 74, pp. 34–46, May 2018.
- [42] A. V. Nikitin, "On the interchannel interference in digital communication systems, its impulsive nature, and its mitigation," *EURASIP J. Adv. Signal Process.*, vol. 2011, no. 1, p. 137, Dec. 2011.
- [43] S. Venkatesan and R. A. Valenzuela, "OFDM for 5G: Cyclic prefix versus zero postfix, and filtering versus windowing," in *Proc. IEEE Int. Conf. Commun. (ICC)*, May 2016, pp. 1–5.
- [44] F. Qamar, M.-N. Hindia, T.-A. Rahman, R. Hassan, K. Dimiyati, and Q.-N. Nguyen, "Propagation characterization and analysis for 5G mmWave through field experiments," *Comput., Mater. Continua*, vol. 68, no. 2, pp. 2249–2264, 2021. [Online]. Available: <http://www.techscience.com/cmcc/v68n2/42209>.
- [45] A. B. Kihero, M. Sohaib J. Solaija, and H. Arslan, "Multi-numerology multiplexing and inter-numerology interference analysis for 5G," 2019, *arXiv:1905.12748*. [Online]. Available: <http://arxiv.org/abs/1905.12748>
- [46] Z. Guo and Y. Fei, "On the cross link interference of 5G with flexible duplex and full duplex," in *Proc. IEEE Wireless Commun. Netw. Conf. Workshops (WCNCW)*, Apr. 2020, pp. 1–4.
- [47] Q. Xue, B. Li, X. Zuo, Z. Yan, and M. Yang, "Cell capacity for 5G cellular network with inter-beam interference," in *Proc. IEEE Int. Conf. Signal Process., Commun. Comput. (ICSPCC)*, Aug. 2016, pp. 1–5.
- [48] M. Vaezi, Z. Ding, and H. V. Poor, *Multiple Access Techniques for 5G Wireless Networks and Beyond*. Springer, 2019, doi: [10.1007/978-3-319-92090-0](https://doi.org/10.1007/978-3-319-92090-0).
- [49] N. Abdallah, H. A. Kadim, and H. A. Sallomi, "Study and analysis of intra-cell interference and inter-cell interference for 5G network," *J. Eng. Sustain. Develop.*, vol. 24, no. 3, pp. 43–57, May 2020.
- [50] K. H. Alzoubi, M. Bin Roslee, and M. A. A. Elgamati, "Interference management of D2D communication in 5G cellular network," in *Proc. Symp. Future Telecommun. Technol. (SOFTT)*, vol. 1, Nov. 2019, pp. 1–7.
- [51] Y. S. Soh, T. Q. S. Quek, M. Kountouris, and H. Shin, "Energy efficient heterogeneous cellular networks," *IEEE J. Sel. Areas Commun.*, vol. 31, no. 5, pp. 840–850, May 2013.
- [52] D. Lopez-Perez, I. Guvenc, G. de la Roche, M. Kountouris, T. Quek, and J. Zhang, "Enhanced intercell interference coordination challenges in heterogeneous networks," *IEEE Wireless Commun.*, vol. 18, no. 3, pp. 22–30, Jun. 2011.
- [53] A. Fehske, G. Fettweis, J. Malmudin, and G. Biczok, "The global footprint of mobile communications: The ecological and economic perspective," *IEEE Commun. Mag.*, vol. 49, no. 8, pp. 55–62, Aug. 2011.
- [54] F. Qamar, M. N. Hindia, T. A. Rahman, R. Hassan, and S. Saleem, "Outdoor propagation channel investigation at 26 GHz for 5G mmWave communication," in *Proc. IEEE Student Conf. Res. Develop. (SCORED)*, Sep. 2020, pp. 189–193.
- [55] S. Ni, J. Zhao, H. H. Yang, and Y. Gong, "Enhancing downlink transmission in MIMO HetNet with wireless backhaul," *IEEE Trans. Veh. Technol.*, vol. 68, no. 7, pp. 6817–6832, Jul. 2019.
- [56] S. Talwar, D. Choudhury, K. Dimou, E. Aryafar, B. Bangerter, and K. Stewart, "Enabling technologies and architectures for 5G wireless," in *IEEE MTT-S Int. Microw. Symp. Dig.*, Jun. 2014, pp. 1–4.
- [57] W. Nam, D. Bai, J. Lee, and I. Kang, "Advanced interference management for 5G cellular networks," *IEEE Commun. Mag.*, vol. 52, no. 5, pp. 52–60, May 2014.
- [58] G. Liu, Y. Huang, Z. Chen, L. Liu, Q. Wang, and N. Li, "5G deployment: Standalone vs. non-standalone from the operator perspective," *IEEE Commun. Mag.*, vol. 58, no. 11, pp. 83–89, Nov. 2020.
- [59] M. Qasim, M. S. Haroon, M. Imran, F. Muhammad, and S. Kim, "5G cellular networks: Coverage analysis in the presence of inter-cell interference and intentional jammers," *Electronics*, vol. 9, no. 9, p. 1538, Sep. 2020.
- [60] N. Bhushan, J. Li, D. Malladi, R. Gilmore, D. Brenner, A. Damnjanovic, R. Sukhavasi, C. Patel, and S. Geirhofer, "Network densification: The dominant theme for wireless evolution into 5G," *IEEE Commun. Mag.*, vol. 52, no. 2, pp. 82–89, Feb. 2014.
- [61] T. U. Hassan and F. Gao, "An active power control technique for downlink interference management in a two-tier Macro-Femto network," *Sensors*, vol. 19, no. 9, p. 2015, Apr. 2019.
- [62] M. K. Hasan, A. F. Ismail, A.-H. Abdalla, W. Hashim, and S. Islam, "Throughput evaluation for the downlink scenario of co-tier interference in heterogeneous network," *ARPJ J. Eng. Appl. Sci.*, vol. 10, no. 21, pp. 9664–9668, 2015.
- [63] A. Nasser, O. Muta, and M. Elsabrouty, "Cross-tier interference management scheme for downlink mMIMO-NOMA HetNet," in *Proc. IEEE 89th Veh. Technol. Conf. (VTC-Spring)*, Apr. 2019, pp. 1–5.
- [64] S. H. Krishnamurthy, R. T. Love, V. Nangia, and R. Nory, "Method and apparatus for mitigating downlink control channel interference," Google Patents 9 307 539, Apr. 5, 2016.
- [65] M.-L.-A. Morel and S. Randriamasy, "Quality of experience-aware enhanced inter-cell interference coordination for self organized HetNet," in *Proc. 10th IFIP Wireless Mobile Netw. Conf. (WMNC)*, Sep. 2017, pp. 1–8.
- [66] H. Y. AlSheyab, S. Choudhury, E. Bedeer, and S. S. Ikki, "Interference minimization algorithms for fifth generation and beyond systems," *Comput. Commun.*, vol. 156, pp. 145–158, Apr. 2020.
- [67] M. S. Haroon, Z. H. Abbas, G. Abbas, and F. Muhammad, "Coverage analysis of ultra-dense heterogeneous cellular networks with interference management," *Wireless Netw.*, vol. 26, no. 3, pp. 2013–2025, Apr. 2020.
- [68] G. Sahu and S. S. Pawar, "An approach to reduce interference using FFR in heterogeneous network," *Social Netw. Comput. Sci.*, vol. 1, no. 2, pp. 1–6, Mar. 2020.
- [69] M. Nakamura, G. K. Tran, and K. Sakaguchi, "Interference management for millimeter-wave mesh backhaul networks," in *Proc. 16th IEEE Annu. Consum. Commun. Netw. Conf. (CCNC)*, Jan. 2019, pp. 1–4.
- [70] A. Nasser, O. Muta, M. Elsabrouty, and H. Gacanin, "Interference mitigation and power allocation scheme for downlink MIMO-NOMA HetNet," *IEEE Trans. Veh. Technol.*, vol. 68, no. 7, pp. 6805–6816, Jul. 2019.
- [71] Y.-S. Byun, H.-G. Kim, and Y.-H. Lee, "Cross-tier interference mitigation in a cellular system with small moving cells," in *Proc. IEEE Pacific Rim Conf. Commun., Comput. Signal Process. (PACRIM)*, Aug. 2019, pp. 1–5.
- [72] Q. Zeng and X. Liu, "Multi-priority based interference mitigation scheme for HetNets uplinks: A frequency hopping method," in *Proc. Int. Symp. Netw., Comput. Commun. (ISNCC)*, Jun. 2019, pp. 1–6.
- [73] I. Budhiraja, S. Tyagi, S. Tanwar, N. Kumar, and N. Guizani, "Subchannel assignment for SWIPT-NOMA based HetNet with imperfect channel state information," in *Proc. 15th Int. Wireless Commun. Mobile Comput. Conf. (IWCMC)*, Jun. 2019, pp. 842–847.
- [74] N. Hassan and X. Fernando, "Interference mitigation and dynamic user association for load balancing in heterogeneous networks," *IEEE Trans. Veh. Technol.*, vol. 68, no. 8, pp. 7578–7592, Aug. 2019.
- [75] D. Pan, B. Li, C. Wang, and W. Wang, "Regional centralized interference alignment for multi-cell heterogeneous networks," in *Proc. IEEE 5th Int. Conf. Comput. Commun. (ICCC)*, Dec. 2019, pp. 1430–1435.
- [76] P. Padmaloshani and S. Nirmala, "Semi-distributed dynamic inter-cell interference coordination scheme for interference avoidance in heterogeneous networks," *ETRI J.*, vol. 42, no. 2, pp. 175–185, Apr. 2020.
- [77] K. Xaphakdy, I. W. Mustika, F. Budi Setiawan, and P. Nugroho, "Resource optimization in heterogeneous networks using discrete firefly algorithm," in *Proc. Int. Conf. Smart Technol. Appl. (ICoSTA)*, Feb. 2020, pp. 1–5.
- [78] M. Jahandideh, P. Azmi, N. Mokari, and M. Forouzesh, "Secure beamforming in relay-aided HetNet with interference nulling," May 2019.
- [79] T. M. Hoang, T. Q. Duong, H. A. Suraweera, C. Tellambura, and H. V. Poor, "Cooperative beamforming and user selection for improving the security of relay-aided systems," *IEEE Trans. Commun.*, vol. 63, no. 12, pp. 5039–5051, Dec. 2015.
- [80] B. Shen, Z. Lei, X. Huang, and Q. Chen, "An interference contribution rate based small cells on/off switching algorithm for 5G dense heterogeneous networks," *IEEE Access*, vol. 6, pp. 29757–29769, 2018.

- [81] A. Gachhadar, M. N. Hindia, F. Qamar, M. H. S. Siddiqui, K. A. Noordin, and I. S. Amiri, "Modified genetic algorithm based power allocation scheme for amplify-and-forward cooperative relay network," *Comput. Electr. Eng.*, vol. 69, pp. 628–641, Jul. 2018.
- [82] X. Yue, Y. Liu, S. Kang, A. Nallanathan, and Z. Ding, "Spatially random relay selection for full/half-duplex cooperative NOMA networks," *IEEE Trans. Commun.*, vol. 66, no. 8, pp. 3294–3308, Aug. 2018.
- [83] D. Hisano, Y. Nakayama, K. Maruta, and A. Maruta, "Deployment design of functional split base station in fixed and wireless multihop fronthaul," in *Proc. IEEE Global Commun. Conf. (GLOBECOM)*, Dec. 2018, pp. 1–6.
- [84] A. BenMimoune and M. Kadoch, "Relay technology for 5G networks and IoT applications," in *Internet of Things: Novel Advances and Envisioned Applications (Studies in Big Data)*, vol. 25, D. Acharjya and M. Geetha, Eds. Cham, Switzerland: Springer, 2017, doi: 10.1007/978-3-319-53472-5_1.
- [85] L. Zhang, M. Xiao, G. Wu, M. Alam, Y.-C. Liang, and S. Li, "A survey of advanced techniques for spectrum sharing in 5G networks," *IEEE Wireless Commun.*, vol. 24, no. 5, pp. 44–51, Oct. 2017.
- [86] A. Abrol and R. K. Jha, "Power optimization in 5G networks: A step towards GrEEn communication," *IEEE Access*, vol. 4, pp. 1355–1374, 2016.
- [87] H. Ju, E. Oh, and D. Hong, "Catching resource-devouring worms in next-generation wireless relay systems: Two-way relay and full-duplex relay," *IEEE Commun. Mag.*, vol. 47, no. 9, pp. 58–65, Sep. 2009.
- [88] J. I. Choi, M. Jain, K. Srinivasan, P. Levis, and S. Katti, "Achieving single channel, full duplex wireless communication," in *Proc. 16th Annu. Int. Conf. Mobile Comput. Netw. (MobiCom)*, 2010, pp. 1–12.
- [89] H. Alves, M. Bennis, R. D. Souza, and M. Latva-Aho, "Enhanced performance of heterogeneous networks through full-duplex relaying," *EURASIP J. Wireless Commun. Netw.*, vol. 2012, no. 1, p. 365, Dec. 2012.
- [90] M. G. Sarret, G. Berardinelli, N. H. Mahmood, M. Fleischer, P. Mogensen, and H. Heinz, "Analyzing the potential of full duplex in 5G ultra-dense small cell networks," *EURASIP J. Wireless Commun. Netw.*, vol. 2016, no. 1, pp. 1–16, Dec. 2016.
- [91] C. D. Nwankwo, L. Zhang, A. Qudus, M. A. Imran, and R. Tafazolli, "A survey of self-interference management techniques for single frequency full duplex systems," *IEEE Access*, vol. 6, pp. 30242–30268, 2018.
- [92] Y. Cai, L. Yang, Y. Zhang, and Z. Qian, "Millimeter wave low-profile relay antennas for 5G full duplex self-interference suppression," in *Proc. IEEE Int. Conf. Signal Process., Commun. Comput. (ICSPCC)*, Oct. 2017, pp. 1–4.
- [93] Y. Liu, Y. Dai, X.-G. Xia, C. Kang, and H. Zhang, "SC-FDE based full-duplex relay communication robust to residual loop interference," *IEEE Wireless Commun. Lett.*, vol. 6, no. 4, pp. 538–541, Aug. 2017.
- [94] W.-S. Lee, M.-J. Kim, and H.-K. Song, "Inter-relay interference cancellation using MIMO detection," *Wireless Pers. Commun.*, vol. 98, no. 2, pp. 1885–1894, Jan. 2018.
- [95] K.-Y. Kim and Y. Shin, "Analysis on inter-relay interference in chirp-based two-path successive relaying protocol," in *Proc. Int. Conf. Green Human Inf. Technol. (ICGHIT)*, Jan. 2019, pp. 43–45.
- [96] B. C. Nguyen, T. M. Hoang, P. T. Tran, and T. N. Nguyen, "Outage probability of NOMA system with wireless power transfer at source and full-duplex relay," *AEU-Int. J. Electron. Commun.*, vol. 116, Mar. 2020, Art. no. 152957.
- [97] K. Eshteiwi, G. Kaddoum, and M. S. Alam, "Ergodic capacity analysis of full duplex relaying in the presence of co-channel interference in V2V communications," *Sensors*, vol. 20, no. 1, p. 261, Jan. 2020.
- [98] B. C. Nguyen and X. N. Tran, "Performance analysis of full-duplex amplify-and-forward relay system with hardware impairments and imperfect self-interference cancellation," *Wireless Commun. Mobile Comput.*, vol. 2019, pp. 1–10, Aug. 2019.
- [99] X. N. Tran, B. C. Nguyen, and D. T. Tran, "Outage probability of two-way full-duplex relay system with hardware impairments," in *Proc. 3rd Int. Conf. Recent Adv. Signal Process., Telecommun. Comput. (SigTelCom)*, Mar. 2019, pp. 135–139.
- [100] K.-Y. Kim and Y. Shin, "Inter-relay interference mitigation for chirp-based two-path successive relaying protocol," *Sensors*, vol. 19, no. 15, p. 3346, Jul. 2019.
- [101] M. U. Amin, J. A. Sheikh, S. A. Parah, and G. M. Bhat, "Analytical analysis and effect of scrambling on inter-relay interference in a tri-sector LTE—A network," *Int. J. Wireless Mobile Comput.*, vol. 14, no. 2, pp. 149–163, 2018.
- [102] T. Charalambous, S. M. Kim, N. Nomikos, M. Bengtsson, and M. Johansson, "Relay-pair selection in buffer-aided successive opportunistic relaying using a multi-antenna source," *Ad Hoc Netw.*, vol. 84, pp. 29–41, Mar. 2019.
- [103] T. Mishina, M. Oiwa, R. Nakai, and S. Sugiura, "Buffer-aided virtual full-duplex cooperative networks exploiting source-to-relay broadcast channels," in *Proc. IEEE 90th Veh. Technol. Conf. (VTC-Fall)*, Sep. 2019, pp. 1–5.
- [104] Y.-B. Kim, K. Yamazaki, and B. C. Jung, "Virtual full-duplex cooperative NOMA: Relay selection and interference cancellation," *IEEE Trans. Wireless Commun.*, vol. 18, no. 12, pp. 5882–5893, Dec. 2019.
- [105] M. Madani Fadoul, M. N. Hindia, K. Dimiyati, E. Hanafi, and I. S. Amiri, "Oblique projection: An interference mitigation for MIMO multihop full-duplex relay," *Trans. Emerg. Telecommun. Technol.*, vol. 31, no. 4, p. e3799, Apr. 2020.
- [106] S. Han, Y. Zhang, W. Meng, C. Li, and Z. Zhang, "Full-duplex relay-assisted macrocell with millimeter wave backhauls: Framework and prospects," *IEEE Netw.*, vol. 33, no. 5, pp. 190–197, Sep. 2019.
- [107] M. M. Fadoul and C. Y. Leow, "Joint nullspace projection-based interference mitigation for full-duplex relay-assisted multicell networks," *IEEE Syst. J.*, vol. 14, no. 2, pp. 2392–2399, Jun. 2020.
- [108] S. Koyanagi and T. Miyajima, "Filter-and-forward-based full-duplex relaying in frequency-selective channels," *IEICE Trans. Fundamentals Electron., Commun. Comput. Sci.*, vol. E102.A, no. 1, pp. 177–185, 2019.
- [109] R. H. Shaik and R. Naidu, "Performance evaluation of energy harvesting based DF system over Nakagami-m fading channels in the presence of co-channel interferences," *Phys. Commun.*, vol. 36, Oct. 2019, Art. no. 100758.
- [110] Q. Yang, J. Ding, and A. Hu, "Secrecy outage performance analysis of DF cognitive relay network with co-channel interference," *Wireless Pers. Commun.*, vol. 107, no. 1, pp. 549–564, Jul. 2019.
- [111] M. K. Pedhadiya, R. K. Jha, and H. G. Bhatt, "Device to device communication: A survey," *J. Netw. Comput. Appl.*, vol. 129, pp. 71–89, Nov. 2019.
- [112] A. Celik, J. Tetzner, K. Sinha, and J. Matta, "5G device-to-device communication security and multipath routing solutions," *Appl. Netw. Sci.*, vol. 4, no. 1, pp. 1–24, Dec. 2019.
- [113] Q. N. Nguyen, M. Arifuzzaman, K. Yu, and T. Sato, "A context-aware green information-centric networking model for future wireless communications," *IEEE Access*, vol. 6, pp. 22804–22816, 2018.
- [114] P. Mach, Z. Becvar, and T. Vanek, "In-band device-to-device communication in OFDMA cellular networks: A survey and challenges," *IEEE Commun. Surveys Tuts.*, vol. 17, no. 4, pp. 1885–1922, Jun. 2015.
- [115] F. Boccardi, R. W. Heath, Jr., A. Lozano, T. L. Marzetta, and P. Popovski, "Five disruptive technology directions for 5G," *IEEE Commun. Mag.*, vol. 52, no. 2, pp. 74–80, Feb. 2014.
- [116] S. Rostami, K. Arshad, and P. Rapajic, "Aggregation-based spectrum assignment in cognitive radio networks," in *Proc. Int. Conf. Adv. Comput. Commun. Syst.*, Dec. 2013, pp. 1–6.
- [117] J. Li, G. Lei, G. Manogaran, G. Mastorakis, and C. X. Mavroumoustakis, "D2D communication mode selection and resource optimization algorithm with optimal throughput in 5G network," *IEEE Access*, vol. 7, pp. 25263–25273, 2019.
- [118] M. Sahlabadi, A. H. Sahlabadi, R. C. Muniyandi, and Z. Shukur, "Evaluation and extracting factual software architecture of distributed system by process mining techniques," *Asia-Pacific J. Inf. Technol. Multimedia*, vol. 6, no. 2, pp. 77–90, Dec. 2017.
- [119] A. Orsino, A. Ometov, G. Fodor, D. Moltchanov, L. Militano, S. Andreev, O. N. C. Yilmaz, T. Tirronen, J. Torsner, G. Araniti, A. Iera, M. Dohler, and Y. Koucheryavy, "Effects of heterogeneous mobility on D2D-and drone-assisted mission-critical MTC in 5G," *IEEE Commun. Mag.*, vol. 55, no. 2, pp. 79–87, Feb. 2017.
- [120] S. Xu, H. Wang, T. Chen, Q. Huang, and T. Peng, "Effective interference cancellation scheme for device-to-device communication underlying cellular networks," in *Proc. IEEE 72nd Veh. Technol. Conf. (Fall)*, Sep. 2010, pp. 1–5.
- [121] D. D. Ningombam, C. G. Lee, and S. Shin, "Interference mitigation for multicast D2D communications underlay cellular networks," in *Proc. Int. Conf. Artif. Intell. Inf. Commun. (ICAIC)*, Feb. 2019, pp. 1–4.
- [122] L. Wang, S. Liu, M. Chen, G. Gui, and H. Sari, "Sidelobe interference reduced scheduling algorithm for mmWave device-to-device communication networks," *Peer Peer Netw. Appl.*, vol. 12, no. 1, pp. 228–240, Jan. 2019.

- [123] H. A. Mustafa, A. R. Ekti, M. Z. Shakir, M. A. Imran, and R. Tafazolli, "Intracell interference characterization and cluster interference for D2D communication," *IEEE Trans. Veh. Technol.*, vol. 67, no. 9, pp. 8536–8548, Sep. 2018.
- [124] S. Shamaei, S. Bayat, and A. M. A. Hemmatyar, "Interference management in D2D-enabled heterogeneous cellular networks using matching theory," *IEEE Trans. Mobile Comput.*, vol. 18, no. 9, pp. 2091–2102, Sep. 2019.
- [125] Y. Ni, J. Zhao, Y. Wang, and H. Zhu, "Beamforming and interference cancellation for D2D communication assisted by two-way decode-and-forward relay node," *China Commun.*, vol. 15, no. 3, pp. 100–111, Mar. 2018.
- [126] S. Doumiati, M. Assaad, and H. A. Artail, "Topological interference management framework for device-to-device communication," *IEEE Wireless Commun. Lett.*, vol. 7, no. 4, pp. 602–605, Aug. 2018.
- [127] R. Ghallab and M. Shokair, "Proposed protocols for interference managements and interference cancellation with AAF relay in D2D communication," in *Proc. 35th Nat. Radio Sci. Conf. (NRSC)*, Mar. 2018, pp. 113–120.
- [128] P. R. Saha, S. Choudhury, and D. R. Gaur, "Interference minimization for device-to-device communications: A combinatorial approach," in *Proc. IEEE Wireless Commun. Netw. Conf. (WCNC)*, Apr. 2019, pp. 1–6.
- [129] J. Ning, L. Feng, F. Zhou, M. Yin, P. Yu, W. Li, and X. Qiu, "Interference control based on stackelberg game for D2D underlying 5G mmWave small cell networks," in *Proc. IEEE Int. Conf. Commun. (ICC)*, May 2019, pp. 1–6.
- [130] X. Zhang, X. Tao, Q. Cui, and J. Bai, "Intra-cell and inter-cell interference-constrained D2D communication underlying cellular networks," *Electron. Lett.*, vol. 51, no. 14, pp. 1117–1119, Jul. 2015.
- [131] S. Joshi and R. K. Mallik, "Coverage and interference in D2D networks with Poisson cluster process," *IEEE Commun. Lett.*, vol. 22, no. 5, pp. 1098–1101, May 2018.
- [132] O. A. Saraereh, A. Ali, I. Khan, and K. Rabie, "Interference analysis for vehicle-to-vehicle communications at 28 GHz," *Electronics*, vol. 9, no. 2, p. 262, Feb. 2020.
- [133] Y. Xu, F. Liu, and P. Wu, "Interference management for D2D communications in heterogeneous cellular networks," *Pervas. Mobile Comput.*, vol. 51, pp. 138–149, Dec. 2018.
- [134] K. Sreelakshmy and L. Jacob, "Simultaneous wireless information and power transfer in heterogeneous cellular networks with underlay D2D communication," *Wireless Netw.*, vol. 26, no. 5, pp. 1–16, 2020.
- [135] E. A. Maher and A. El-Mahdy, "Uplink power control for D2D-enabled HetNet with partial CSI via fractional programming," in *Proc. 15th Annu. Conf. Wireless Demand Netw. Syst. Services (WONS)*, Jan. 2019, pp. 119–125.
- [136] M. A. Elshatshat, S. Papadakis, and V. Angelakis, "Improving the spectral efficiency in dense heterogeneous networks using D2D-assisted eCIC," in *Proc. IEEE 23rd Int. Workshop Comput. Aided Modeling Design Commun. Links Netw. (CAMAD)*, Sep. 2018, pp. 1–6.
- [137] R. Sukjaimuk, Q. Nguyen, and T. Sato, "A smart congestion control mechanism for the green IoT sensor-enabled information-centric networking," *Sensors*, vol. 18, no. 9, p. 2889, Aug. 2018.
- [138] F. Qamar, M. N. Hindia, K. Dimiyati, K. A. Noordin, M. B. Majed, T. A. Rahman, and I. S. Amiri, "Investigation of future 5G-IoT millimeter-wave network performance at 38 GHz for urban microcell outdoor environment," *Electronics*, vol. 8, no. 5, p. 495, May 2019.
- [139] Ericsson, "Cellular networks for massive IoT-enabling low power wide area applications," Ericsson AB, White Paper, Jan. 2016.
- [140] J. M. Talavera, L. E. Tobón, J. A. Gómez, M. A. Culman, J. M. Aranda, D. T. Parra, L. A. Quiroz, A. Hoyos, and L. E. Garreta, "Review of IoT applications in agro-industrial and environmental fields," *Comput. Electron. Agricult.*, vol. 142, pp. 283–297, Nov. 2017.
- [141] R. Hassan, F. Qamar, M. K. Hasan, A. H. M. Aman, and A. S. Ahmed, "Internet of Things and its applications: A comprehensive survey," *Symmetry*, vol. 12, no. 10, p. 1674, Oct. 2020.
- [142] G. A. Akpakwu, B. J. Silva, G. P. Hancke, and A. M. Abu-Mahfouz, "A survey on 5G networks for the Internet of Things: Communication technologies and challenges," *IEEE Access*, vol. 6, pp. 3619–3647, 2018.
- [143] P. P. Ray, "A survey of IoT cloud platforms," *Future Comput. Informat. J.*, vol. 1, nos. 1–2, pp. 35–46, Dec. 2016.
- [144] M. D. Mendy and Y. Faye, "A comparative study of wireless technologies coexistence mechanisms in IoT: A survey," in *ICT Analysis and Applications (Lecture Notes in Networks and Systems)*, vol. 154. Singapore: Springer, 2021, doi: 10.1007/978-981-15-8354-4_18.
- [145] R. Tian, L. Ma, Z. Wang, and X. Tan, "Cognitive interference alignment schemes for IoT oriented heterogeneous two-tier networks," *Sensors*, vol. 18, no. 8, p. 2548, Aug. 2018.
- [146] Z. Liu, J. Liu, Y. Zeng, and J. Ma, "Covert wireless communications in IoT systems: Hiding information in interference," *IEEE Wireless Commun.*, vol. 25, no. 6, pp. 46–52, Dec. 2018.
- [147] L. Clavier, T. Pedersen, I. Larrad, M. Lauridsen, and M. Egan, "Experimental evidence for heavy tailed interference in the IoT," *IEEE Commun. Lett.*, vol. 25, no. 3, pp. 692–695, Mar. 2021.
- [148] L. Li, Y. Xu, Z. Zhang, J. Yin, W. Chen, and Z. Han, "A prediction-based charging policy and interference mitigation approach in the wireless powered Internet of Things," *IEEE J. Sel. Areas Commun.*, vol. 37, no. 2, pp. 439–451, Feb. 2019.
- [149] S. Baidya and M. Levorato, "Content-aware cognitive interference control for urban IoT systems," *IEEE Trans. Cognit. Commun. Netw.*, vol. 4, no. 3, pp. 500–512, Sep. 2018.
- [150] S. Liu, L. Xiao, Z. Han, and Y. Tang, "Eliminating NB-IoT interference to LTE system: A sparse machine learning-based approach," *IEEE Internet Things J.*, vol. 6, no. 4, pp. 6919–6932, Aug. 2019.
- [151] G. J. Gonzalez, F. H. Gregorio, and J. Cousseau, "Interference analysis in the LTE and NB-IoT uplink multiple access with RF impairments," in *Proc. IEEE 23rd Int. Conf. Digit. Signal Process. (DSP)*, Nov. 2018, pp. 1–4.
- [152] H. Kim, S. C. Cho, and Y. Lee, "Interference analysis of guardband NB-IoT system," in *Proc. Int. Conf. Inf. Commun. Technol. Converg. (ICTC)*, Oct. 2018, pp. 1370–1372.
- [153] E. Tuyishimire and B. A. Bagula, "Modelling and analysis of interference diffusion in the Internet of Things: An epidemic model," in *Proc. Conf. Inf. Commun. Technol. Soc. (ICTAS)*, Mar. 2020, pp. 1–6.
- [154] Z. Li, Y. Liu, K. G. Shin, J. Liu, and Z. Yan, "Interference steering to manage interference in IoT," *IEEE Internet Things J.*, vol. 6, no. 6, pp. 10458–10471, Dec. 2019.
- [155] N.-N. Dao, M. Park, J. Kim, J. Paek, and S. Cho, "Resource-aware relay selection for inter-cell interference avoidance in 5G heterogeneous network for Internet of Things systems," *Future Gener. Comput. Syst.*, vol. 93, pp. 877–887, Apr. 2019.
- [156] S. J. Maeng, M. Deshmukh, İ. Güvenç, H. Dai, and A. Bhuyan, "Interference analysis and mitigation for massive access aerial IoT considering 3D antenna patterns," 2020, *arXiv:2002.01050*. [Online]. Available: <http://arxiv.org/abs/2002.01050>
- [157] S. Zafar, S. Jangsher, O. Bouachir, M. Aloqaily, and J. Ben Othman, "QoS enhancement with deep learning-based interference prediction in mobile IoT," *Comput. Commun.*, vol. 148, pp. 86–97, Dec. 2019.
- [158] Y. Liu, X. Yuan, Y.-C. Liang, and Z. Han, "Machine learning based iterative detection and multi-interference cancellation for cognitive IoT," *IEEE Commun. Lett.*, vol. 24, no. 9, pp. 1995–1999, Sep. 2020.
- [159] S. J. Maeng, M. A. Deshmukh, İ. Guvenç, and A. Bhuyan, "Interference mitigation scheme in 3D topology IoT network with antenna radiation pattern," in *Proc. IEEE 90th Veh. Technol. Conf. (VTC-Fall)*, Sep. 2019, pp. 1–6.
- [160] J. G. Andrews, S. Buzzi, W. Choi, S. V. Hanly, A. Lozano, A. C. K. Soong, and J. C. Zhang, "What will 5G be?" *IEEE J. Sel. Areas Commun.*, vol. 32, no. 6, pp. 1065–1082, Jun. 2014.
- [161] S. S. Ioushua and Y. C. Eldar, "Pilot sequence design for mitigating pilot contamination with reduced RF chains," *IEEE Trans. Commun.*, vol. 68, no. 6, pp. 3536–3549, Jun. 2020.
- [162] O. Elijah, C. Y. Leow, T. A. Rahman, S. Nunoo, and S. Z. Iliya, "A comprehensive survey of pilot contamination in massive MIMO—5G system," *IEEE Commun. Surveys Tuts.*, vol. 18, no. 2, pp. 905–923, 2nd Quart., 2016.
- [163] U. Challita, W. Saad, and C. Bettstetter, "Cellular-connected UAVs over 5G: Deep reinforcement learning for interference management," 2018, *arXiv:1801.05500*. [Online]. Available: <http://arxiv.org/abs/1801.05500>
- [164] R. Amorim, H. Nguyen, J. Whigard, I. Z. Kovacs, T. B. Sorensen, D. Z. Biro, M. Sorensen, and P. Mogensen, "Measured uplink interference caused by aerial vehicles in LTE cellular networks," *IEEE Wireless Commun. Lett.*, vol. 7, no. 6, pp. 958–961, Dec. 2018.
- [165] L. Liu, S. Zhang, and R. Zhang, "Multi-beam UAV communication in cellular uplink: Cooperative interference cancellation and sum-rate maximization," *IEEE Trans. Wireless Commun.*, vol. 18, no. 10, pp. 4679–4691, Oct. 2019.
- [166] W. Mei, Q. Wu, and R. Zhang, "Cellular-connected UAV: Uplink association, power control and interference coordination," *IEEE Trans. Wireless Commun.*, vol. 18, no. 11, pp. 5380–5393, Nov. 2019.

- [167] W. Mei and R. Zhang, "Uplink cooperative NOMA for cellular-connected UAV," *IEEE J. Sel. Topics Signal Process.*, vol. 13, no. 3, pp. 644–656, Jun. 2019.
- [168] L. Cariou and R. Stacey, "Report for inter-BSS interference avoidance," Google Patents, 2018.
- [169] R. Kim, Y. Kim, and H. Lim, "Inter-BS interference-aware transmission coordination for millimeter wave networks," *IEEE Wireless Commun. Lett.*, vol. 6, no. 3, pp. 350–353, Jun. 2017.
- [170] Z. Marzi, U. Madhoo, and H. Zheng, "Interference analysis for mm-wave picocells," in *Proc. IEEE Global Commun. Conf. (GLOBECOM)*, Dec. 2015, pp. 1–6.
- [171] F. Boccardi, H. Shokri-Ghadikolaei, G. Fodor, E. Erkip, C. Fischione, M. Kountouris, P. Popovski, and M. Zorzi, "Spectrum pooling in mmWave networks: Opportunities, challenges, and enablers," *IEEE Commun. Mag.*, vol. 54, no. 11, pp. 33–39, Nov. 2016.
- [172] B. L. Ng, V. Chandrasekhar, Y.-H. Nam, and J. Kim, "Beam management of downlink data channel and downlink control channel for 5G next radio systems," Google Patents 10 148 337, Dec. 4, 2018.
- [173] D. Tsolkas, N. Passas, and L. Merakos, "Alleviating control channel interference in femto-overlaid LTE-advanced networks," *IEEE Commun. Mag.*, vol. 51, no. 10, pp. 192–200, Oct. 2013.
- [174] Z. Bharucha, A. Saul, G. Auer, and H. Haas, "Dynamic resource partitioning for downlink femto-to-macro-cell interference avoidance," *EURASIP J. Wireless Commun. Netw.*, vol. 2010, no. 1, pp. 1–12, Dec. 2010.
- [175] Z. Bharucha, G. Auer, and T. Abe, "Downlink femto-to-macro control channel interference for LTE," in *Proc. IEEE Wireless Commun. Netw. Conf.*, Mar. 2011, pp. 1259–1264.
- [176] M. Shafi, A. F. Molisch, P. J. Smith, T. Haustein, P. Zhu, P. De Silva, F. Tufvesson, A. Benjebbour, and G. Wunder, "5G: A tutorial overview of standards, trials, challenges, deployment, and practice," *IEEE J. Sel. Areas Commun.*, vol. 35, no. 6, pp. 1201–1221, Jun. 2017.
- [177] Y. Kashino, N. Honma, M. Tsunezawa, and K. Nishimori, "Channel capacity of multi-user full-duplex MIMO in actual outdoor environment," in *Proc. Int. Symp. Antennas Propag. (ISAP)*, 2016, pp. 332–333.
- [178] A. Kawagoe, Y. Kashino, M. Tsunezawa, N. Honma, and N. Takemura, "Non-linear inter-user interference reduction for multi-user full-duplex MIMO system," in *Proc. Int. Symp. Antennas Propag. (ISAP)*, Oct. 2017, pp. 1–2.
- [179] *Evolved Universal Terrestrial Radio Access Network (E-UTRAN): Overall Description; Stage 2*, 3GPP TS 36.300 v14, 2017, vol. 4.
- [180] V. Vukadinovic, K. Bakowski, P. Marsch, I. D. Garcia, H. Xu, M. Sybis, P. Sroka, K. Wesolowski, D. Lister, and I. Thibault, "3GPP C-V2X and IEEE 802.11p for vehicle-to-vehicle communications in highway platooning scenarios," *Ad Hoc Netw.*, vol. 74, pp. 17–29, May 2018.
- [181] *IEEE Standard for Information Technology*, IEEE Standard 802.11 p-2010, IEEE Computer Society, 2010.
- [182] A. Ghosal and M. Conti, "Security issues and challenges in V2X: A survey," *Comput. Netw.*, vol. 169, Mar. 2020, Art. no. 107093.
- [183] M. D. Foegelle, "New and continuing measurement challenges for 5G mmwave and beamforming technologies," in *Proc. 13th Eur. Conf. Antennas Propag. (EuCAP)*, 2019, pp. 1–5.
- [184] R. J. Mailloux, *Phased Array Antenna Handbook*. Artech House, 2017.
- [185] J. Noh, T. Kim, J. Seol, and C. Lee, "Zero-forcing based hybrid beamforming for multi-user millimeter wave systems," *IET Commun.*, vol. 10, no. 18, pp. 2670–2677, Dec. 2016.
- [186] M. Majidzadeh, A. Moilanen, N. Tervo, H. Pannanen, A. Tolli, and M. Latva-Aho, "Partially connected hybrid beamforming for large antenna arrays in multi-user MISO systems," in *Proc. IEEE 28th Annu. Int. Symp. Pers., Indoor, Mobile Radio Commun. (PIMRC)*, Oct. 2017, pp. 1–6.
- [187] S. Sonmez, I. Shayea, S. A. Khan, and A. Alhammedi, "Handover management for next-generation wireless networks: A brief overview," in *Proc. IEEE Microw. Theory Techn. Wireless Commun. (MTTW)*, vol. 1, Oct. 2020, pp. 35–40.
- [188] L. Lei, Y. Yuan, T. X. Vu, S. Chatzinotas, and B. Ottersten, "Learning-based resource allocation: Efficient content delivery enabled by convolutional neural network," in *Proc. IEEE 20th Int. Workshop Signal Process. Adv. Wireless Commun. (SPAWC)*, Jul. 2019, pp. 1–5.
- [189] F. Zhao and Q. Tang, "A KNN learning algorithm for collusion-resistant spectrum auction in small cell networks," *IEEE Access*, vol. 6, pp. 45796–45803, 2018.
- [190] H. Fourati, R. Maaloul, and L. Chaari, "A survey of 5G network systems: Challenges and machine learning approaches," *Int. J. Mach. Learn. Cybern.*, vol. 12, no. 2, pp. 1–47, 2020.
- [191] S. D'Oro, A. Zappone, S. Palazzo, and M. Lops, "A learning approach for low-complexity optimization of energy efficiency in multicarrier wireless networks," *IEEE Trans. Wireless Commun.*, vol. 17, no. 5, pp. 3226–3241, May 2018.
- [192] J. Zhang, H. Du, P. Zhang, J. Cheng, and L. Yang, "Performance analysis of 5G mobile relay systems for high-speed trains," *IEEE J. Sel. Areas Commun.*, vol. 38, no. 12, pp. 2760–2772, Dec. 2020.
- [193] A. A. A. El-Banna, B. M. ElHalawany, A. B. Zaky, J. Z. Huang, and K. Wu, "Machine learning-based multi-layer multi-hop transmission scheme for dense networks," *IEEE Commun. Lett.*, vol. 23, no. 12, pp. 2238–2242, Dec. 2019.
- [194] M. Noura and R. Nordin, "A survey on interference management for device-to-device (D2D) communication and its challenges in 5G networks," *J. Netw. Comput. Appl.*, vol. 71, pp. 130–150, Aug. 2016.
- [195] I. Ioannou, V. Vassiliou, C. Christophorou, and A. Pitsillides, "Distributed artificial intelligence solution for D2D communication in 5G networks," *IEEE Syst. J.*, vol. 14, no. 3, pp. 4232–4241, Sep. 2020.
- [196] A. H. Alquhali, M. Roslee, M. Y. Alias, and K. S. Mohamed, "D2D communication for spectral efficiency improvement and interference reduction: A survey," *Bull. Electr. Eng. Informat.*, vol. 9, no. 3, pp. 1085–1094, Jun. 2020.
- [197] N. Javaid, A. Sher, H. Nasir, and N. Guizani, "Intelligence in IoT-based 5G networks: Opportunities and challenges," *IEEE Commun. Mag.*, vol. 56, no. 10, pp. 94–100, Oct. 2018.
- [198] M. Aramon, G. Rosenberg, E. Valiante, T. Miyazawa, H. Tamura, and H. G. Katzgraber, "Physics-inspired optimization for quadratic unconstrained problems using a digital annealer," *Frontiers Phys.*, vol. 7, p. 48, Apr. 2019.
- [199] L. Xiao, X. Wan, X. Lu, Y. Zhang, and D. Wu, "IoT security techniques based on machine learning: How do IoT devices use AI to enhance security?" *IEEE Signal Process. Mag.*, vol. 35, no. 5, pp. 41–49, Sep. 2018.
- [200] B. Chatterjee, N. Cao, A. Raychowdhury, and S. Sen, "Context-aware intelligence in resource-constrained IoT nodes: Opportunities and challenges," *IEEE Des. Test. Comput.*, vol. 36, no. 2, pp. 7–40, Apr. 2019.
- [201] J. Marco, Q. Hernandez, A. Muñoz, Y. Dong, A. Jarabo, M. H. Kim, X. Tong, and D. Gutierrez, "DeepToF: Off-the-shelf real-time correction of multipath interference in time-of-flight imaging," *ACM Trans. Graph.*, vol. 36, no. 6, pp. 1–12, Nov. 2017.



MARAJ UDDIN AHMED SIDDIQUI received the B.S. degree in electronic engineering from the Sir Syed University of Engineering and Technology, Karachi, Pakistan, in 2010, and the M.Eng.St. degree in telecommunications engineering from the Faculty of Information Science and Technology, University of Wollongong, Wollongong, NSW, Australia, in July 2013. He is currently serving as a Network Engineer for Orient Energy Systems Pvt. Ltd., Karachi. His research interests include interference management, millimeter-wave communication, massive multiple input multiple output (MIMO) systems, the IoT, D2D communication, and performance enhancement for future wireless networks.



FAIZAN QAMAR received the B.E. degree in electronics from Hamdard University, Karachi, Pakistan, in 2010, the M.E. degree in telecommunication from NED University, Karachi, in 2013, and the Ph.D. degree in wireless networks from the Faculty of Engineering, University of Malaya, Kuala Lumpur, Malaysia, in October 2019. He is currently serving as a Senior Lecturer for the Faculty of Information Science and Technology, Universiti Kebangsaan Malaysia (UKM), Malaysia.

He has more than nine years of research and teaching experience. He has authored and coauthored numerous ISI & Scopus journal articles and IEEE conference papers. He is also serving as a reviewer in more than 15 high reputation journals with different publishers, such as IEEE, Elsevier, Springer, Wiley, and Hindawi. His research interests include interference management, millimeter-wave communication, ad-hoc networks, the Internet of Things, D2D communication, and quality of service enhancement for future wireless networks.



FAISAL AHMED received the bachelor's degree in computer engineering from the Usman Institute of Technology, Karachi, Pakistan, the master's degree in electrical engineering from the Blekinge Institute of Technology, Karlskrona, Sweden, and the Ph.D. degree from the Tallinn University of Technology (Tal Tech.), Estonia. His Ph.D. thesis deals with the design of energy prediction methods combined with transient computing techniques for the implementation of energy-efficient in the context of the Internet of Things (IoT). He has published various articles on the web of science and one is an Oxford press. After his Ph.D., he moved to Sweden and joined Ericson as a Team Leader of the Network Infrastructure (EEINFRA). In 2019, he joined the University of Tartu in the capacity of a Junior Lecturer at the Computer Science Department.



QUANG NGOC NGUYEN (Member, IEEE) received the B.Eng. degree in information technology, Honor the Computer Science Program conducted in English from the Posts and Telecommunications Institute of Technology (PTIT), Hanoi, Vietnam, in 2012, and the M.Sc. and Ph.D. degrees from Waseda University, Tokyo, Japan, in 2015 and 2019, respectively. He became a one of the youngest faculty members of PTIT. He has been a Research Associate with Waseda University, since 2018. He is currently an Assistant Professor with the Faculty of Science and Engineering, Waseda University. He has hosted and participated in many research projects, including the collaborative EU-Japan research projects funded by the European Commission's Horizon 2020 Programme (e.g., the Green ICN and 5G! Pagoda projects), and the Ministry of Internal Affairs and Communication (MIC) of Japan. His research has also been funded by the Ministry of Economy, Trade and Industry (METI) of Japan, Waseda University, and Fujitsu Ltd. and Fujitsu Lab. His research interests include network design, green networking, future Internet, wireless communication systems, beyond 5G (B5G)/6G, the Internet of Things (IoT), sensor networks, data science, artificial intelligence (AI), applied intelligence, the Internet of Vehicles (IoV), combinatorial optimization/multi-objective optimization (MOO), network slicing, information systems, game theory, and technology standardization. He is also a Senior Member of the European Alliance for Innovation (EAI). Also, he has been a reviewer of top journals in the field of communications and computer engineering as well as computer science, e.g., IEEE JOURNAL ON SELECTED AREAS IN COMMUNICATIONS (JSAC), IEEE INTERNET OF THINGS JOURNAL, *Computer Science Review*, IEEE ACCESS, *Sensors* (Basel, Switzerland), and *IEEE Communications Standards Magazine*. He was the sole Awardee of Asia Special Scholarship for Fall

2013 admission to the Graduate School of Global Information and Telecommunication Studies (GITS), Waseda University. He was a recipient of young author recognition awarded by the International Telecommunication Union for the young first-author of highly potential research under 30 years old, and actively contributed to many ITU-T standardization activities related to Information-Centric Networking (ICN) and Future Internet architecture. Besides, he had experience with editorial and conference organizations. He has served as an Organizing Committee Member (OCM) for the International Conference on Computer Science and Software Engineering 2020, the 3rd International Conference on Computer Science & Cloud Computing 2020, and the Asia Pacific Society for Computing and Information Technology (APSCIT) Annual Meeting 2019, as well as a Session Chair for IEEE ICC 2017. He has been a Guest Editor and a Keynote Speaker with the 2nd International Conference on Artificial Intelligence and Advanced Manufacturing (AIAM 2020), Shanghai, China, and the IEEE International Conference on Artificial Intelligence and Computer Applications (ICAICA 2021), Dalian, China, June 2021. He has also served as the sole and lead Editor of a book entitled *Congestion Control: Design, Applications and Protocols* (Nova Science Publishers, March 2021). In addition, he is also a Topic Editor of *Electronics*, Switzerland, and a Series Editor of *Atlantis Highlights in Engineering* and *Advances in Engineering Research* (WoS).



ROSILAH HASSAN (Senior Member, IEEE) received the degree in electronic engineering from Hanyang University, Seoul, South Korea, the M.E.E. degree in computer and communication from Universiti Kebangsaan Malaysia (UKM), Malaysia, in 1999, and the Ph.D. degree in mobile communication from the University of Strathclyde, U.K., in 2008. She worked as an Engineer with Samsung Electronic Malaysia, Seremban, Malaysia, in 1997. She is currently an Associate Professor with UKM. She is also a Senior Lecturer with UKM for more than 20 years. She is also with the Centre for Cyber Security, Faculty of Information Science and Technology (FTSM), UKM. She is also the Head of the Network Communication Technology (NCT) Laboratory in her Faculty. Her research interests include mobile communications, networking, the IoT, ICT, 4IR, and big data. She has had experience as an External Examiner for Ph.D. and master's for both national and international levels. She is also an active member of IEEE, WIE, Malaysia Society for Engineering (MySET), Malaysian Board of Technologists (MBoT), and IET. She is also a reviewer of several IEEE conferences and national and international journals. She had supervised to completion to date seven Ph.D. students and 12 ongoing Ph.D. students. She also had experience as the Deputy Director of Academic Entrepreneurship and Innovation for seven years at University. Her task is to organize the compulsory course for 13 faculties with more than 5000 students.

...