

Received March 5, 2021, accepted March 18, 2021, date of publication March 29, 2021, date of current version April 9, 2021.

Digital Object Identifier 10.1109/ACCESS.2021.3069593

Control Strategies of Different Hybrid Energy Storage Systems for Electric Vehicles Applications

**AMIT KUMER PODDER¹, OISHIKHA CHAKRABORTY¹, (Student Member, IEEE),
SAYEMUL ISLAM¹, NALLAPANENI MANOJ KUMAR²,
AND HASSAN HAES ALHELOU^{3,4}, (Senior Member, IEEE)**

¹Department of Electrical and Electronic Engineering, Khulna University of Engineering & Technology, Khulna 9203, Bangladesh

²School of Energy and Environment, City University of Hong Kong, Hong Kong

³School of Electrical and Electronic Engineering, University College Dublin, Dublin 4, D04 V1W8 Ireland

⁴Department of Electrical Power Engineering, Faculty of Mechanical and Electrical Engineering, Tishreen University, Lattakia 2230, Syria

Corresponding authors: Hassan Haes Alhelou (alhelou@ieee.org) and Nallapaneni Manoj Kumar (nallapanenichow@gmail.com)

The work of Hassan Haes Alhelou was supported in part by the Science Foundation Ireland (SFI) through the SFI Strategic Partnership Programme under Grant SFI/15/SPP/E3125, and in part by the UCD Energy Institute.

ABSTRACT Choice of hybrid electric vehicles (HEVs) in transportation systems is becoming more prominent for optimized energy consumption. HEVs are attaining tremendous appreciation due to their eco-friendly performance and assistance in smart grid notion. The variation of energy storage systems in HEV (such as batteries, supercapacitors or ultracapacitors, fuel cells, and so on) with numerous control strategies create variation in HEV types. Therefore, choosing an appropriate control strategy for HEV applications becomes complicated. This paper reflects a comprehensive review of the imperative information of energy storage systems related to HEVs and procurable optimization topologies based on various control strategies and vehicle technologies. The research work classifies different control strategies considering four configurations: fuel cell-battery, battery-ultracapacitor, fuel cell-ultracapacitor, and battery-fuel cell-ultracapacitor. Relative analysis among different control techniques is carried out based on the control aspects and operating conditions to illustrate these techniques' pros and cons. A parametric comparison and a cross-comparison are provided for different hybrid configurations to present a comparative study based on dynamic performance, battery lifetime, energy efficiency, fuel consumption, emission, robustness, and so on. The study also analyzes the experimental platform, the amelioration of driving cycles, mathematical models of each control technique to demonstrate the reliability in practical applications. The presented recapitulation is believed to be a reliable base for the researchers, policymakers, and influencers who continuously develop HEVs with energy-efficient control strategies.

INDEX TERMS Electric vehicle, energy storage systems, battery, ultracapacitors, fuel cell, hybrid electric vehicle, control strategy, vehicle topology.

NOMENCLATURE

AMT	Automatic Manual Transmission	FLC	Fuzzy Logic Control
BERS	Braking Energy Regeneration Strategy	HESS	Hybrid Energy Storage System
BPNN	Back Propagation Neural Network	HEV	Hybrid Electric Vehicle
DP	Dynamic Programming	HEVS	Hybrid Electric Vehicle System
ECMS	Energy Consumption Minimization Strategy	HWDC	Highway Drive Cycle
EMR	Energetic Microscopic Representation	ICE	Internal Combustion Engine
EMS	Energy Management System	IFOC	Indirect Field-Oriented Control
ESS	Energy Storage System	IUDC	Indian Urban Driving Cycle
EV	Electric Vehicle	MPC	Model Predictive Control
FC	Fuel cell	NEDC	New European Driving Cycle
		NYCC	New York City Cycle
		PFS	Power Following Strategy
		PI	Proportional Integral

The associate editor coordinating the review of this manuscript and approving it for publication was Yang Li¹.

PID	Proportional Integral Derivative
PMP	Pontryagin's Minimum Principle
PSO	Particle Swarm Optimization
SC	Supercapacitor
SDP	Stochastic Dynamic Programming
SFTP	Supplement Federal Test Procedure
SOC	State of Charge
TTCAN	Time-Triggered Controller Area Network
UC	Ultracapacitor
UDS	Urban Dynamometer Schedule

I. INTRODUCTION

The world is moving towards an era full of facilities updated with more recent inventions; pollutions are rising simultaneously where constant harm is evident to all living beings. Conventional vehicles with an internal combustion engine (ICE) contribute a lot to this issue resulting in the greenhouse effect with a noticeable emission rate [1]. Hence, the idea of electric vehicles (EVs) came up with different energy storage devices such as batteries, supercapacitors (SCs) or ultracapacitors (UCs), and fuel cells (FCs) [2]. Modification over these EVs created hybrid electric vehicles (HEVs) as a combination of the formerly mentioned sources with increased efficiency and sufficient aid in ensuring uninterrupted power supply in vehicles. Very intelligently, the emission rate of CO₂ and CO can get lessened by proper installation of HEVs. Battery life can be successfully extended up to a satisfactory level; FC's longevity can now be found in an easier norm [3]. Researchers have utilized different control strategies to provide real-time application over a long distance [4].

Integration of UCs as an auxiliary power source in any system helps reduce stress over battery or FC by taking care of transient load conditions. The whole process runs under the maintenance of state of charge (SOC) level for the regarding sources injected, taking any new topology into account, or sometimes as a strategy to control converters considered in the system. Proportional integral (PI) controller [5], fuzzy logic control (FLC) [6], model predictive control (MPC) [7], rule-based control [8], wavelet-based control [9], linear mode control [10], real-time performance-based control and many more control strategies are being suggested in recent times. Further research works on the betterment of HEVs are going on.

A detailed classification of plug-in HEVs based on the control logic being utilized and an overview of the controllers is depicted in [11]. Each control strategy shows its conveniences and drawbacks. The trade-off between efficiency and cost significantly affects the production and performance efficacy of electric vehicle technology. The presented global optimization methods reduce costs for multiple variables, lessen emissions, and increase mileage. A critical study based on various control strategies is presented in [12]. The analysis identifies several uncertainties and complexities in terms of the robustness of the electric vehicle technology. A lack of proper direction for future work on several kinds of HEVs

composed of multiple energy storage systems (ESSs) with a preferable outline of control strategies and energy management schemes is stated in [11], [12]. An elaborated discussion on optimal sizing of various ESSs that introduces the modified particle swarm optimization algorithm to determine the optimal sizing is presented in [13]. The study analyzes numerous parameters, driving cycles, cost-effectiveness to design an optimal ESS sizing for different configurations: only Battery, only UC, and Battery and UC. A review analysis of the present state of different ESSs of EV is done in [14], including the battery classification, the battery's current condition, and the power charging capability. Although few battery technologies show high potential for providing superior performance, experimentation over these technologies has not been completed yet. Moreover, the trending lithium-based EV battery having a restriction in energy density, limitation in the life cycle, and high initial cost. More research needs to be conducted for the betterment of the performance of EV batteries [15]. A wavelet function-based indirect field-oriented control (WT-IFOC) is proposed in [16] that varies different parameters such as speed and steering angle input to verify different test strategies' efficacy. The controller illustrates a smooth controlling platform to determine minimal peak overshoot, suitability in smooth propagation of EVs on the curved road, and quick settling time over the PID (Proportional-integral-derivative) controller under numerical consideration. A comparative analysis is performed in [17] that shows a relative estimation of the dynamic programming (DP) and Pontryagin's minimum principle (PMP) for the HEV. The study includes the automatic manual transmission (AMT) concept to analyze the trade-off of fuel consumption and the gear shifting frequency. Again a research work in [18] illustrates a comparative study of different ESSs that indicates UC for greater efficacy. The analysis also shows the production cost of the formation of different types of batteries. Energy density for hydrocarbons is seen much higher, but energy efficiency is the lowest in this case. However, optimization of EV's efficiency and performance and its charging infrastructure is also suggested for making EV a viable choice in transportation. EV's current status, the large-scale development process, EV's sustainability in transportation systems, different charging modes, communication technology, and component maintenance are discussed in [19]. For example, a set of significant challenges, safety limitations, overcoming higher starting price of EVs, development in current charging technologies, and increasing battery management efficiency, are also presented. A comprehensive analysis of different control strategies to characterize battery performances under various situations is demonstrated in [20]. The research work considers multi-power sources, sizing of ESS, stability, distributed networks to explore battery performances.

The significance of hybrid ESS (HESS) over the individual ESS in EV is highlighted in [21]. Integration of several ESSs (such as UC, battery, and FC) enhances system stability, charging-discharging rate, driving range, storage lifetime,

TABLE 1. Contributions of the proposed research work in comparison to other research works.

Contributions	This Paper	[15]	[28]	[29]	[30]	[31]	[32]	[33]	[34]	[35]	[36]	[37]
Integration of EMS with EV	✓	✓	✓	✓	✓	✓	✓	✓	✓	✓	✓	✓
Categorization of control strategies based on hybrid energy system	✓	✗	✓	✓	✗	✓	✓	✗	✓	✓	✓	✓
Pros and cons of control strategy	✓	✗	✗	✓	✓	✓	✓	✓	✓	✓	✗	✗
Cross comparison among hybrid configurations	✓	✗	✗	✗	✗	✗	✗	✗	✗	✗	✗	✗
Simulation platform	✓	✓	✓	✗	✗	✗	✗	✗	✓	✓	✗	✗
Mathematical equations	✓	✓	✓	✓	✗	✓	✓	✓	✗	✗	✗	✓
Amelioration of improved driving cycle	✓	✓	✓	✗	✗	✗	✓	✗	✓	✓	✗	✓
Location representation for research works	✓	✓	✗	✗	✗	✓	✗	✗	✗	✗	✗	✗

✓ means the contribution is included and ✗ means the contribution is not included in the research work

and cost. An informative comparison among different control techniques is presented in [22] that emphasizes structural complexity and HEV optimization. The study includes genetic algorithm, stochastic dynamic programming, energy consumption minimization strategy, and neural network method for comparative analysis of various schemes. Furthermore, battery-UC-based HESS’s main issues are discussed in [23] that consider aging mechanism, state estimation, and lifetime prediction. A comparative analysis for FC-UC-based HESS is done in [24] to choose the optimal power allocation strategy from the PID-based and rule-based approach [24]. The DP algorithm and a semi-physical experimental platform are included to verify the two strategies’ effectiveness. The experimental results indicate the rule-based strategy is more efficient than the PID-based strategy. Again, an improved power splitting strategy is proposed in [25] for the hybrid propulsion system that utilizes DP and multiple-grained velocity prediction to verify the proposed scheme for different hybrid energy resources. The method forms a semi-physical platform to maintain simulation activities in hardware-in-the-loop simulation. An energy management strategy for battery-FC-UC-based hybrid source vehicles is also proposed in [26] that considers power capability as significant parameters for battery and UC and utilizes finite state machines. A rule-based power distribution strategy is proposed in [27] for the hybrid power system. The process includes the Bayes Monte Carlo approach to estimate the lifetime of Battery and SC.

Therefore, for ensuring the convenience of getting into the appropriate way to control different HEVs individually, this paper upholds a detailed review of different existing control strategies for optimized performance with suitable vehicle topologies based on different ESSs with merits–demerits, simulation, and experimentation capabilities. Table 1. illustrates the contributions of the proposed research work that compare with other research works. The research work’s significant contribution is categorizing the selected control strategies in terms of their source configuration. The categorization is further expanded into different terms considering utilized techniques. The study presents a cross-comparison

among the utilized ESSs and the pros and cons of selected control strategies in HEV. A comprehensive analysis of key parameters, driving cycles, simulation platform, mathematical equations, and research work location is also presented so that the researchers in this field can grasp the insights of HEV and its numerous control strategies.

The rest of the paper consists of five more sections. Section II and III present the fundamental information about the commonly used energy storage devices in EVs and familiarization with the hybrid configuration of different ESSs of HEVs, respectively. Section IV notifies comparison among the control strategies under discussion for the techniques mentioned above. Finally, a positive outcome and the conclusion are drawn in sections V and VI, respectively.

II. COMMONLY USED ENERGY STORAGE DEVICES FOR EVs

The commonly used energy storage devices are battery, FC, and UC. They are used in EVs sometimes as primary energy sources or sometimes as secondary energy sources when utilized in hybrid mode. The mentioned sources are detailed below with their generic model.

A. BATTERY

The battery is an excellent and widely used energy source that can be found on every single electronic device. It acts as a significant power source even in the HEV system. The battery in HEVs is connected to a DC bus through a DC/DC converter, and the battery voltage equals the DC bus voltage. Battery SOC demonstrates an important concept that controls the hybrid vehicle system’s behavior. The battery serves a fast response to peak power during acceleration and restores power during deceleration like UC. **Figure 1** is a representation of different batteries that are common in HEVs. **Figure 2** presents a battery model where a variable voltage source with series resistance is employed. The battery voltage output can be expressed as

$$V_{bat} = E_{bat} - R_{i}i_{bat} \tag{1}$$

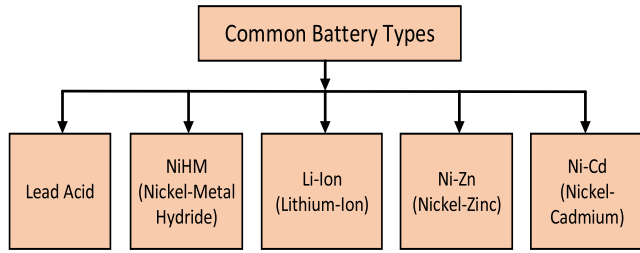

FIGURE 1. Commonly used batteries in HEVs.

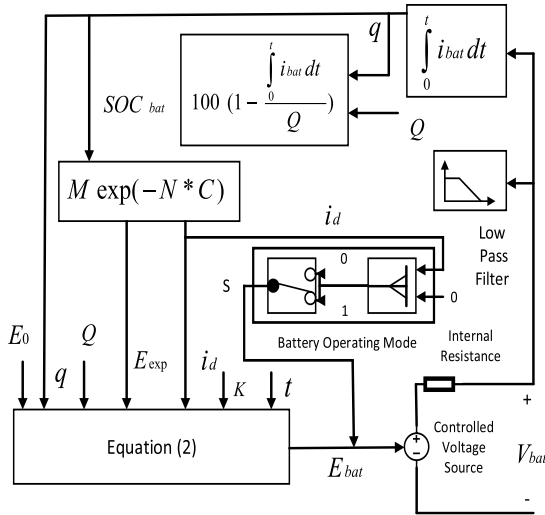

FIGURE 2. Battery model [38].

where V_{bat} presents the battery output voltage, E_{bat} presents the open-circuit voltage, R_i presents the internal resistance and i_{bat} presents the battery current. The battery voltage dynamics can be expressed for both charge and discharge cycles as

$$\begin{cases} E_{bat_dis} = E_0 - K \frac{Q}{Q-q} i_d - K \frac{Q}{Q-q} q + M \exp(-N * q) \\ E_{bat_ch} = E_0 - K \frac{Q}{q+0.1Q} i_d - K \frac{Q}{Q-q} q + M \exp(-N * q) \end{cases} \quad (2)$$

where E_0 presents the constant voltage, i_d presents the filtered current from low pass filter to battery current, K acts as the polarization constant, Q is the maximum battery capacity, M shows the exponential voltage, q is the extracted capacity, and N is the exponential capacity.

The battery SOC can be expressed as

$$SOC = 100 \left(1 - \frac{\int_0^t i_{bat} dt}{Q} \right) \quad (3)$$

B. SCs/UCs

SC and UC are considered familiar energy sources in the HEV system, but they differ in the length of electrodes and storage capacity. Several research works named this source

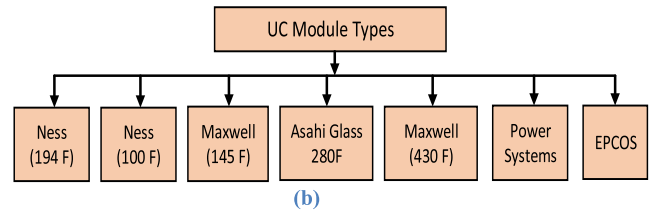
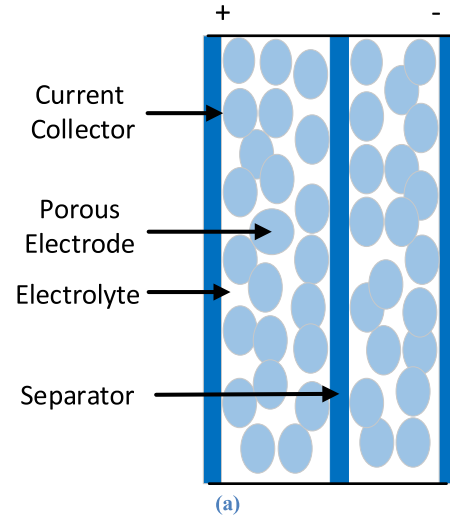

FIGURE 3. (a) Basic construction of UC and (b) commonly used UC modules in EVs.

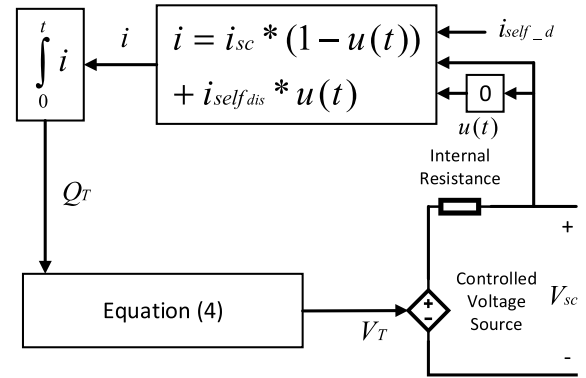

FIGURE 4. Equivalent circuit of SC in MATLAB platform [40].

as UC while others as SC instead of UC. Authors remain neutral in expressing UC and SC for each research work. Battery and SC have the common goal to store charge, but SC can store and discharge charge swiftly compared to the battery. The basic construction of SC in Figure 3(a) represents two parallel electrodes separated by a small distance. When an external voltage is applied to it, the negative electrode stores positive ions, and the positive electrode stores negative ions. SC provides transient power during acceleration and restores power during braking while other energy sources serve steady-state power to the HEV. Figure 3(b) represents some UCs that are commonly used in HEVs.

The equivalent circuit of SC is shown in Figure 4, and the SC output voltage can be presented by the Stem equation

below.

$$V_{sc} = \frac{N_s Q_T d}{N_p N_e \epsilon \epsilon_0 A_i} + \frac{2 N_e N_s R T}{F} \sinh^{-1} \left(\frac{Q_T}{N_p N_e^2 A_i \sqrt{8 R T \epsilon \epsilon_0 C}} \right) - R_{sc} * i_{sc} \quad (4)$$

where $Q_T = \int i_{sc} dt$. The self-discharge phenomenon can be represented by modifying the electric charge of SC as follows ($i_{sc} = 0$)

$$Q_T = \int i_{self_dis} dt \quad (5)$$

$$i_{self_dis} = \begin{cases} \frac{C_T \alpha_1}{1 + s R_{sc} C_T} & \text{if } t - t_{oc} \leq t_3 \\ \frac{C_T \alpha_2}{1 + s R_{sc} C_T} & \text{if } t_3 < t - t_{oc} \leq t_4 \\ \frac{C_T \alpha_3}{1 + s R_{sc} C_T} & \text{if } t - t_{oc} > t_4 \end{cases} \quad (6)$$

where, α_1, α_2 and α_3 present the constraints and the rate of change of SC voltage during the time intervals (t_{oc}, t_3), (t_3, t_4) and (t_4, t_5) respectively.

C. FC

The FC converts chemical energy into electrical energy and acts as the primary power source in HEVs. FC's physical structure consists of an anode, cathode, and an electrolytic membrane. The anode supplies hydrogen, and the cathode supplies oxygen, as shown in **Figure 5(a)**. Protons pass through the electrolytic membrane, and electrons pass through the load. FC provides a continuous steady-state power supply to the HEV, but it cannot supply transient power during acceleration and deceleration supplied by other sources. FC proves itself as an efficient energy source with no emission. Several FC types utilized in EVs are shown in **Figure 5(b)**.

Figure 6 presents a FC stack model. Two types of irreversible voltage drops are illustrated: activation overvoltage and ohmic overvoltage. Due to the irreversible voltage drops, the actual FC potential is less than the ideal FC potential. The output voltage of the FC is the combination of the Nernst instantaneous voltage, activation overvoltage, and ohmic overvoltage. FC output voltage can be expressed as follows.

$$V_{fc} = E_{Nernst} + \eta_{act} + \eta_{ohm} \quad (7)$$

where Nernst instantaneous voltage $E_{Nernst} = N[E_0 + \frac{RT}{2F} \ln(\frac{P_{H_2} \sqrt{P_{O_2}}}{P_{H_2O}})]$, activation overvoltage, $\eta_{act} = -B \ln(C I_{fc})$, and ohmic overvoltage, $\eta_{ohm} = -I_{fc} R_{int}$. By putting the mentioned values in Eqn. (7), the output voltage of FC can be rewritten as

$$V_{fc} = N \left[E_0 + \frac{RT}{2F} \ln \left(\frac{P_{H_2} \sqrt{P_{O_2}}}{P_{H_2O}} \right) \right] - B \ln(C I_{fc}) - I_{fc} R_{int} \quad (8)$$

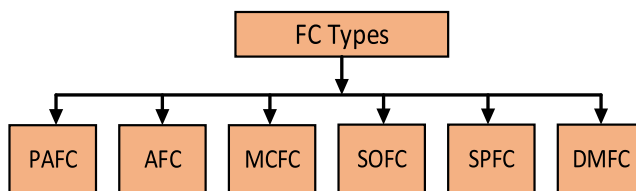
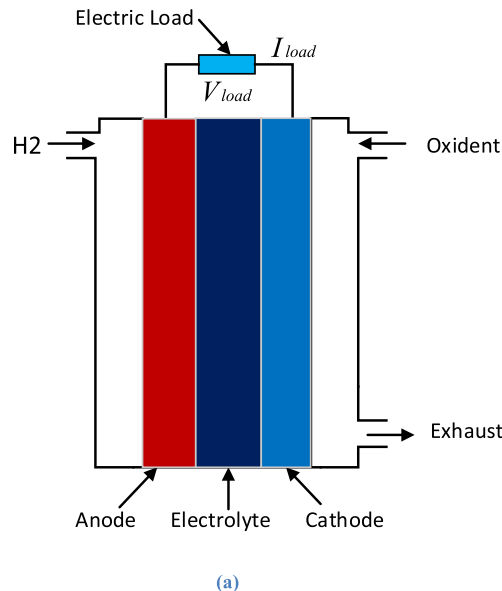

FIGURE 5. (a) Basic construction of FC [39] and (b) commonly used FC modules in EVs. Note that PAFC: Phosphoric acid fuel cell, AFC: Alkaline fuel cell, MCFC: Molten-carbonate fuel cell, SOFC: Solid oxide fuel cell, SPFC: Solid polymer fuel cell, and DMFC: Direct methanol fuel cell.

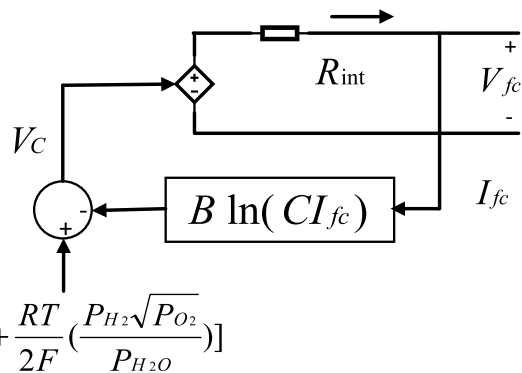

FIGURE 6. FC stack model [38].

III. HYBRID ENERGY STORAGE SYSTEM (HESS) FOR EVs

HEVs are defined as vehicles using two or more energy sources or storage such that at least one provides electrical energy. For instance, a typical HEV contains an engine with a fuel tank and an electric motor with a battery. HEV configuration can be subdivided into the following four types based on the ESSs, and they are discussed below.

A. BATTERY-FC-UC

Such technology's motto is the proper maintenance of the energy distribution between its various sources for fulfilling

the power demand at any mission requested. The configuration reduces hydrogen consumption effectively and provides an efficient performance during restless operation at a long driving range as all the sources are available. The composition's primary challenge is the battery current fluctuations, the battery SOC level, and the storage capacity.

B. FC-UC

In this configuration, FC and UC are the sources of energy. For FC, voltage is at the highest point during zero current flow. It drops with the increasing current due to the activation overvoltage and ohmic resistance losses in the membrane. A sharp voltage drop occurs at a high current when the reactant gases' transport cannot follow the reaction's amount. FC should supply limited current. The slow power response of FC can be compensated by the fast power response of UC to maintain the specified performance of EV.

C. BATTERY-UC

The battery-UC configuration demonstrates a capable and satisfactory energy system for EV that minimizes cost, improves system's reliability, and provides load-leveling capability. The arrangement reduces energy losses and prolongs battery lifetime. UC assists the battery in reducing stress during peak hours. The battery-UC HESS's constructional classification is presented in **Figure 7**, where the HESS is primarily classified in three sectors: passive, semi-active, and active. The semi-active structure is further categorized into two sections: UC semi-active and battery semi-active, and active topology is classified as parallel and cascaded active topology.

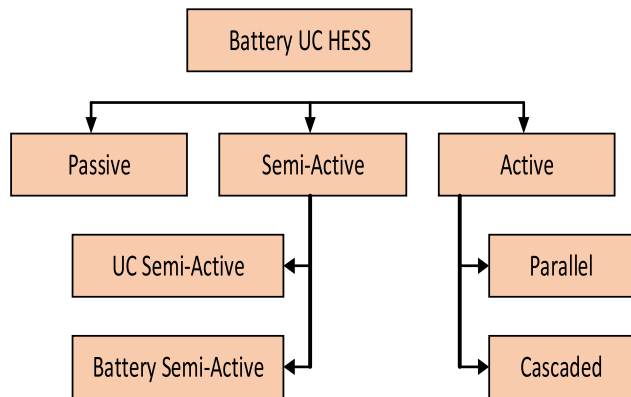

FIGURE 7. The topological classification of battery-UC HESS [41].

D. BATTERY-FC

This technology shows FC working as the primary power source and battery as a secondary support system. FC can take care of higher load demand due to increased energy density properties to charge up the associated battery module. If the amount of fuel reaches near the permissible lower limit, the battery also comes into action to aid the system in

continuing a sustainable performance. Thus efficiency gets increased.

The schematic representation of the four HESS mentioned above is shown in **Figure 8**. Table 2 demonstrates a parametric comparison among FC-UC-Battery, FC-UC, UC-Battery, and FC-Battery configuration. The table illustrates a relative comparison of different terms: key parameters, initial load demand, transient response, battery SOC, driving cycle, simulation platform, and so on. Table 3 represents a cross-comparison among the four configurations mentioned above that emphasizes presenting relative information.

IV. CONTROL STRATEGIES FOR DIFFERENT HESSs

A. CONTROL STRATEGIES FOR BATTERY-UC HESSs

1) MPC STRATEGY

An effective MPC strategy is proposed in [42]. This strategy comprises the backpropagation neural network (BPNN) and PMP that focuses on economic fuel consumption and lengthen the battery's longevity. The MPC applies the BPNN algorithm to predict vehicle speed and running characteristics at different driving modes. PMP diminishes the estimation load and saves time. The real-time optimization scheme is implemented in MATLAB/ Simulink environment.

The system maintains the impartiality between complexity, performance, and economy by considering the following equation.

$$P_b + \eta P_{sc} = P_d \tag{9}$$

P_b and P_{sc} represent the output of battery and SC, respectively, P_d is the demand power, and η is the converter's coefficient. The SOC of battery and UC are expressed by the Eqns (10) and (11), respectively.

$$SOC_b = \frac{I_b}{Q} = -\frac{V_b - \sqrt{V_b^2 - 4R_b P_b}}{2R_b Q} \tag{10}$$

$$SOC_{sc} = -\frac{SOC_{sc} V_{sc,max} - \sqrt{(SOC_{sc} V_{sc,max})^2 - 4R_{sc} P_{sc}}}{2R_{sc} C_{sc} V_{sc,max}} \tag{11}$$

where, SOC_b and SOC_{sc} are the SOC of battery and SC, respectively and V_b , R_b , and Q represents open-circuit voltage, equivalent internal resistance, and the rated capacity of the battery, respectively. $V_{sc,max}$, C_{sc} and R_{sc} present the maximum rated voltage, the capacity of the SC, and equivalent internal resistance, respectively. The schematic diagram of the MPC-based HESS is illustrated in **Figure 9(a)**.

Another MPC strategy is proposed in [43], as shown in **Figure 9(b)**, which considers the fast response of UC and the battery's comparatively slow response for extending the battery lifetime. It maintains the battery and UC SOC as well as voltage at a reference level. The strategy maintains the total required input current by the below Eqn. (12).

$$i_{total\ req} = \frac{P_{total\ req}}{V_{bus}} \tag{12}$$

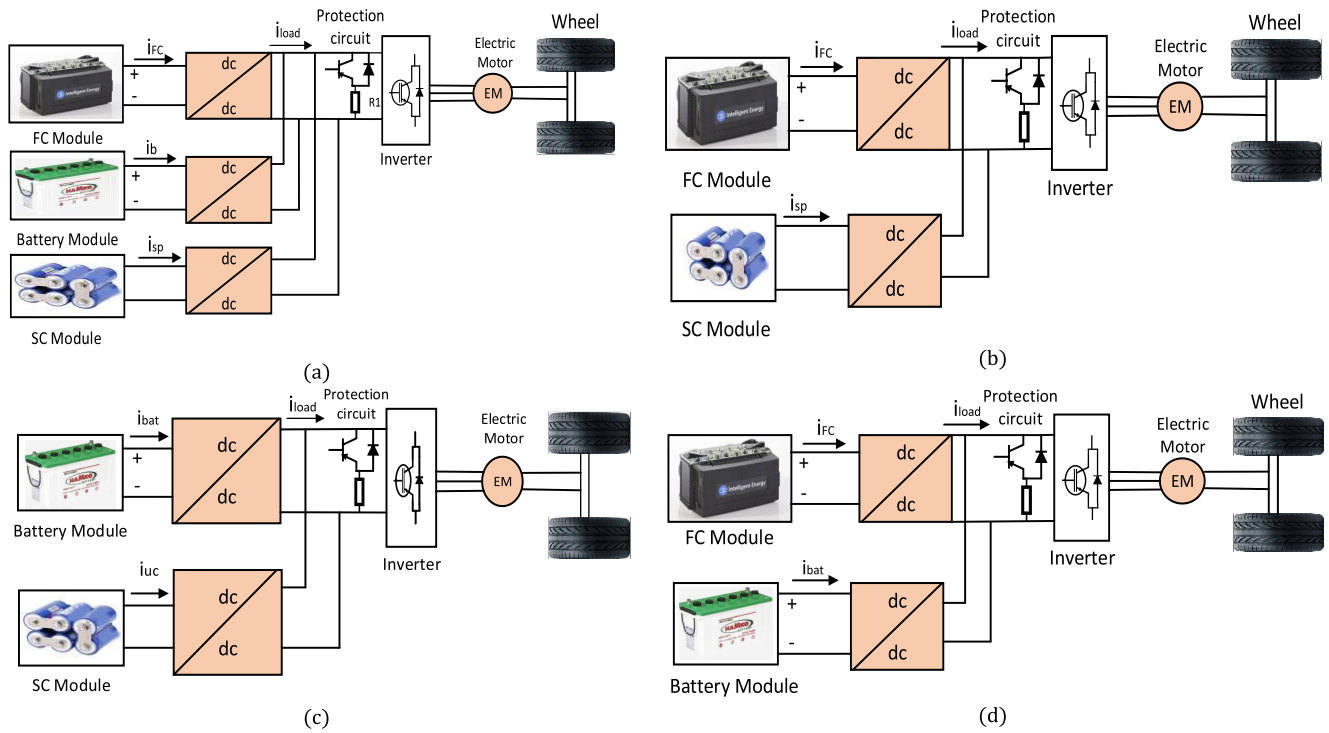

FIGURE 8. A schematic representation of HEV system for (a) FC-battery-SC HESS configuration (b) FC-SC HESS configuration (c) Battery-SC HESS configuration (d) FC-battery HESS configuration. Note that SC is also known as UC.

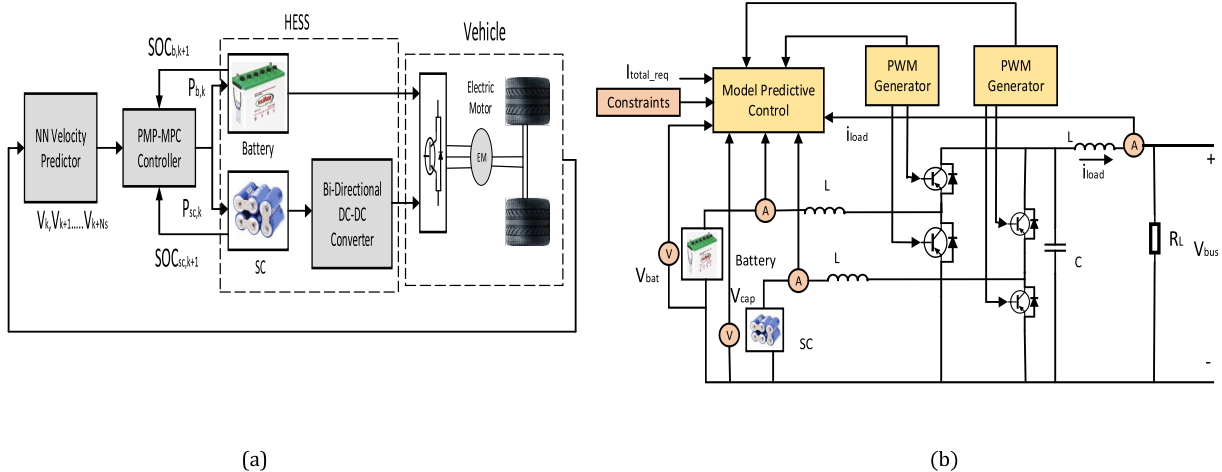

FIGURE 9. Representation of schematic diagram of battery-SC HEV for (a) MPC strategy proposed in [42], and (b) MPC strategy proposed in [43].

where $p_{total\ req}$ is the required power that is supplied or stored by the power source and v_{bus} presents the constant DC bus voltage.

A comparison between the mentioned two existing MPC strategy for battery-UC HESS is presented in Table 4 based on the control aspects, operating conditions, and their applications.

2) CONTROL STRATEGY FOR SEMI-ACTIVE BATTERY-UC TOPOLOGY

A modified semi-active topology is presented in [41]. The proposed configuration implies a peak current control that

assures a stable DC voltage and lessens the current fickleness. A bidirectional DC/DC converter is utilized in the control scheme. The converter has three separate operating modes: standalone mode, boost mode, and buck mode. The configuration focuses on an efficient regulation of DC voltage and the reduction of overall cost by reducing the components' size. Validation is committed through the dSPACE-1103 controller board implemented by MATLAB/Simulink software. Reference [44] presents another semi-active topology having the advantages and utility of employing an SC in an HEV. SC provides transient power during acceleration, restores the loss of power during deceleration, and lessens the battery's

TABLE 2. The parametric comparison among FC-Battery, FC-UC, Battery-UC, and FC-Battery-UC topology.

Parameters of comparison	FC-Battery	FC-UC	Battery-UC	FC-Battery-UC
System configuration	<ul style="list-style-type: none"> Primary source: FC Auxiliary source: Battery 	<ul style="list-style-type: none"> Primary source: FC Auxiliary source: UC 	<ul style="list-style-type: none"> Primary source: Battery Auxiliary source: UC 	<ul style="list-style-type: none"> Primary source: FC Auxiliary source: Battery and UC
Initial load demand	Handled by Battery	Handled by FC	Handled by Battery	Handled by FC or Battery
Transient load demand	Handled by FC	Handled by UC	Always handled by UC	Handled by UC
Implementation process	Easy	Easy	Easy	Sometimes gets complex
Equivalent fuel consumption	Moderate	Low	Not relevant	Lowest
Energy conversion efficiency	High	High	Higher	Highest
SOC estimation	FC will charge the battery when battery SOC is under the low level	FC will charge the UC when UC SOC is under the low level	When UC SOC is under a low level, the battery will charge the UC. Otherwise, UC will charge the battery	When the SOC of the battery and UC is under a low level, the FC will charge the battery and UC
Dynamic performance	Good	Good	Good	Better
Stress on battery	Lessened by FC	Reduced by UC	Reduced by UC	Reduced by UC and FC
Robustness	Pleasant	Pleasant	Pleasant	Pleasant
Battery lifetime	Not relevant	Long	Long	Longest
Emission	Low	Low	No emission	Low
Availability	Commercially available	Commercially available	Commercially available	Commercially available
Reliability and flexibility	Good	Good	Good	Excellent
Frequency management	<ul style="list-style-type: none"> FC controls the high-frequency components The battery holds the low-frequency components 	<ul style="list-style-type: none"> UC handles the high-frequency components FC handles the low-frequency components 	<ul style="list-style-type: none"> UC manages the high-frequency components The battery controls the low-frequency components 	<ul style="list-style-type: none"> UC manages the high-frequency components FC and battery hold the low-frequency components
Performance on different driving cycle	Satisfactory	Satisfactory	Satisfactory	Satisfactory
Simulation probability on suitable software	Exists	Exists	Exists	Exists

pressure. The average power, p_{ave} from the initial time to final time can be expressed as

$$p_{ave} = \frac{1}{t} \int_0^t px(t) dt \tag{13}$$

where $px(t)$ represents the instantaneous power supplied by Battery or SC.

3) REAL-TIME ENERGY MANAGEMENT STRATEGY (EMS)

Real-time energy management is proposed in [45] that determines real-time solutions on various driving cycles. Three standard driving cycles are considered: WLTC class2, NEDC with urban and highway parts, and ARTEMIS. PMP is

applied to lessen the adaptation problem. It is compared with other controls like filtering and DP to verify the proposed scheme's pertinence. A reduced-scale power hardware-in-loop (HIL) simulation platform is utilized to verify the experiment. Another improved real-time power-split control strategy is proposed in [46]. It is a small-scale experimental platform that focuses on improving power management through various sources and components performance. This concept is evaluated using MATLAB/Simulink environment. Three operating modes are presented: starting and acceleration mode, constant speed mode, and deceleration or braking mode. A three-wheel vehicle under Indian road conditions is demonstrated to implement this strategy. This strategy

TABLE 3. The cross-comparison among the four different HESSs for EVs.

Comparison Over	UC-Battery	FC-Battery	UC-FC	UC-FC-Battery
UC-Battery	-----	<ul style="list-style-type: none"> • Considers the sustainability, power availability, and dynamic responses • Slow down battery aging • Good dynamic performance and faster response • Fast computational speed and significant cost reductions 	<ul style="list-style-type: none"> • Minimizes the FC power demand and improves durability • Illustrates system stability, quick response capability, low overshoot, and zero steady current • Provides minimization of hydrogen consumption • Prolong battery lifetime. • Optimize dynamic power regulation 	<ul style="list-style-type: none"> • Provides fast dynamic response • Offers long battery life • Provides improved reliability and efficiency based on hydrogen consumption and SOC of battery/UC • UC assists FC and battery by providing fast response during the peak power demand
FC-Battery	<ul style="list-style-type: none"> • Reduce the fuel consumption and raise the operational efficiency of FCs • Prolong the battery's lifetime • Lessens FC warm-up time • Utilizes uncompensated power from the battery 	-----	<ul style="list-style-type: none"> • Reduces fuel consumption and slows down battery aging • Prolong battery lifetime. • Shows effectiveness and potential feasibility. • Raises the operation efficiency • Ensures tight dc bus voltage regulation 	<ul style="list-style-type: none"> • Increases the overall power capability • Ensures regenerating the excess power during decelerations • A fast dynamic system, reliable, and flexible • Optimizes the efficiency • Provides optimal component sizing
UC-FC	<ul style="list-style-type: none"> • Guarantees continuity of service and safe functioning • Maintains SC current to its reference value • Good dynamic performance and faster response • Fast computational speed 	<ul style="list-style-type: none"> • Provides stable and robust performance • Ensures optimal component sizing • Maintains optimal power distribution 	-----	<ul style="list-style-type: none"> • Minimizes the FC power demand transitions and improves durability • Ensures optimal distribution of energy • Provides stable and robust performance • UC acts as a peak power source that provides a fast response during peak power demand
UC-FC-Battery	<ul style="list-style-type: none"> • UC provides fast response and maintains the operation in a feasible range • Improves the system performance like power density, dynamic response, and reliability 	<ul style="list-style-type: none"> • Demonstrates effectiveness and potential feasibility • Lessens the downside effect of slow dynamic response 	<ul style="list-style-type: none"> • Ensures safe and efficient system • Guarantees continuity of service and safe functioning • Improves reliability and efficiency • The fast dynamic response, flexible and reliable 	-----

TABLE 4. Comparison among two existing MPC strategies for Battery-UC HESSs.

Ref.	Year	Institution	Objective	Control Aspect	Operating Condition	Application
[42]	2020	College of Information Engineering, Zhejiang University of Technology, Hangzhou, China	<ul style="list-style-type: none"> • Real-time optimization of energy consumption, • Enhances battery lifetime 	<ul style="list-style-type: none"> • Utilize BPNN to predict vehicle velocities at different driving cycles. • Utilize The PMP to reduce computational time. 	Three non-linear MPC: F-NMPC, T-NMPC and C-NMPC.	<ul style="list-style-type: none"> • V2X communication • Automated HEV.
[43]	2014	The University of New South Wales Sydney, Australia	<ul style="list-style-type: none"> • Monitors the response time • Utilizes the SOC of battery and UC 	<ul style="list-style-type: none"> • Utilize a better battery model and a voltage sensor for battery and UC to achieve optimal outcome. 	The approach is operated to validate the change of weight, reference current, reference voltage, battery voltage, UC voltage, battery current, UC current.	<ul style="list-style-type: none"> • Photovoltaic system.

reduces the RMS current and thus advances the battery performance and lengthen the battery lifetime. The reference current of battery and UC can be computed as follow

$$I_{ref} = \frac{p_{UC}}{v_{UC}} \tag{14}$$

$$I_{batt_reg} = \frac{p_{demand}}{v_{batt}} - I_{reg} \tag{15}$$

where I_{ref} and v_{batt} represents the reference current and battery terminal voltage respectfully and p_{demand} presents the power demand. p_{UC} is the power supplied or

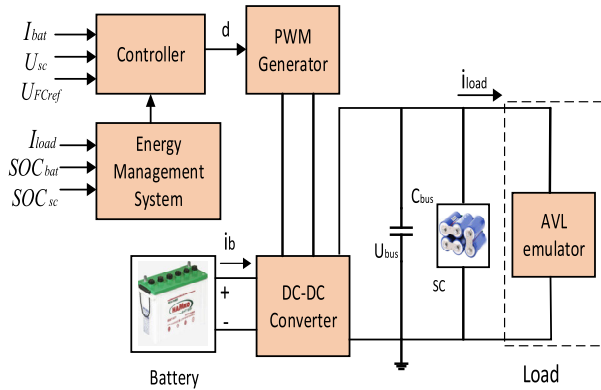

FIGURE 10. A schematic diagram of battery-SC-based HEV using rule based EMS [48].

stored by the UC and v_{UC} represents the voltage across the UC.

Another real-time control strategy is presented in [47]. It provides step-by-step problem-solving tools that target multi-objective optimization problems and then reformulate the issues using weighted no-preference method. The final step of this approach recommends the Karush-Kuhn-Tucker method to formulate the solutions. The experiment is simulated using an advanced vehicle simulator (ADVISOR). Simulation results show a prolonged battery lifetime and excellent power distribution between sources. The efficiency η of this approach is expressed as

$$\eta = \frac{\int p_{load}(t) d(t)}{\int p_{load}(t) d(t) + \int p_{loss}(t) d(t)} \quad (16)$$

where $p_{load}(t)$ represents the real-time power demand of the load and p_{loss} represents the real-time power loss of the system.

Table 5 presents a comparative analysis of three existing real-time control strategies for battery-UC HESS.

4) RULE-BASED EMS

A rule-based EMS is proposed in [48] that is a semi-active hybrid topology. It exhibits the attributes of the UC and prolongs the battery lifetime. The two driving cycles tested in this topology are the USA Urban Dynamometer Schedule (UDS) and the New European Driving Cycle (NEDC).

At first, a current controller is used to manage a stable current flow between the sources. Then a voltage controller is apprised to control the SC SOC within a reference limit. The total power required by the vehicle p_{veh} can be presented a

$$p_{veh} = p_{roll} + p_{aer} + p_{slope} + p_{acc} \quad (17)$$

where p_{roll} is the rolling resistance power, p_{aer} is the aerodynamic drag power, p_{slope} is the slope resistance power and p_{acc} presents the acceleration resistance power. The schematic representation of the proposed EMS is presented in Figure 10.

The aerodynamic drag power can be described as

$$p_{aer} = \frac{1}{\eta} \frac{c_{aer} A_{aer}}{76140} \mu_{eh}^3 \quad (18)$$

The rolling resistance power can be expressed as

$$p_{roll} = \frac{\mu_{veh}}{\eta} \frac{Mgf \cos(\alpha)}{3600} \quad (19)$$

The slope resistance power can be expressed as

$$p_{slope} = \frac{\mu_{veh}}{\eta} \frac{Mg \sin(\alpha)}{3600} \quad (20)$$

The acceleration resistance power can be represented as

$$p_{acc} = \frac{\mu_{veh}}{\eta} \frac{\delta M}{3600} \frac{d\mu_{veh}}{dt} \quad (21)$$

The total current demand can be expressed as

$$I_{load} = \frac{p_{veh}}{U_{bus}} \quad (22)$$

where η is the drive efficiency, M is the mass of the vehicle, f is the rolling resistance coefficient, g is the gravity constant, α is the road slope angle, μ_{veh} is the vehicle velocity, U_{bus} presents the bus voltage.

The last stages imply the other two steps like SOC of the sources and modes of operation. The implementation results in MATLAB/Simulink show a comparatively longer battery lifetime and minimum costing. A scale factor α_{SOC} is calculated in this strategy to keep a balance condition between battery SOC and SC SOC.

$$\alpha_{SOC} = \frac{\frac{SOC_{UC \ High} - SOC_{UC \ Low}}{SOC_{UC \ Low}}}{\frac{SOC_{B \ High} - SOC_{B \ Low}}{SOC_{B \ Low}}} \quad (23)$$

Another rule-based power split strategy is proposed in [49]. This unit is tested in different driving cycles: Manhattan (low-speed transit bus operation) and UDDSC (high-speed bus operation).

Three stages are demonstrated. In the first stage, the different modes of operation (charge or discharge) are considered. In the next steps, some parameters are referred to in terms of the SOC of the source and operating modes. The mentioned two existing rule-based control strategies are compared in Table 6 based on their objectives, control aspects, and driving cycles.

5) New Battery-UC EMS

For maintaining a stable DC operating voltage and SOC of battery and UC, a strategy is proposed in [50], which uses a small DC/DC converter compared to others. It presents a small-scale test that is implemented and validated in PSAT software. The experiment represents four operating modes: (i) vehicle low constant speed operation, (ii) vehicle high constant speed operation, (iii) acceleration, and (iv) deceleration. Furthermore, for improving the power management between sources and SOC of the battery and SC, a strategy is proposed in [51]. It is tested in an Urban Driving Cycle-ECE-15 and

TABLE 5. Comparison among three existing real-time control strategies for Battery-UC HESSs.

Ref.	Year	Institution	Objective	Control aspect	Cycles/operating condition
[45]	2018	Laboratory of Electrical Engineering and Power Electronics, University of Lille, Villeneuve d'Ascq, France	<ul style="list-style-type: none"> Power sharing management Real-time optimal outcomes 	<ul style="list-style-type: none"> Employ PMP for optimal outcomes Compares with other EMSs such as filtering strategy, λ-control, and DP 	Three standard driving cycles: <ul style="list-style-type: none"> WLTC class2 NEDC with urban and highway parts ARTEMIS urban
[46]	2019	SSN College of Engineering, Kalavakkam, India	<ul style="list-style-type: none"> Reduction of RMS current Lengthen the battery lifetime Govern the power flow from sources 	<ul style="list-style-type: none"> A three wheel light electric vehicle platform A bidirectional dc-dc converter 	Three operating modes: <ul style="list-style-type: none"> Starting and acceleration mode Constant speed or cruising mode Deceleration or braking mode
[47]	2019	ShanghaiTech University, Shanghai 201210, China	<ul style="list-style-type: none"> Efficient response of UC to the system Stability of dc-link voltage and proper management of power flow. Feasible computational time 	<ul style="list-style-type: none"> Utilize a Multi-Objective Optimization problem (MOO) that considers loss functions Employ weighted method and no-preference method to the MOO Introduce Karush-Kuhn-Tucker method for final solutions 	Four typical driving cycles: <ul style="list-style-type: none"> UDDS NYCC NEDC INDIA_URBAN_SAMPLE

TABLE 6. Comparison between two existing rule based control strategies for Battery-UC hybrid energy systems.

Ref.	Year	Institution	Objective	Control aspect	Driving cycles
[48]	2016	State key laboratory of automotive simulation and control, Jilin University, China	<ul style="list-style-type: none"> Observation of the UC characteristics Maximize the system efficiency Lengthen the battery lifetime 	<ul style="list-style-type: none"> A current controller is first introduced to control the load current flow A voltage controller is then employed to monitor SC SOC 	Two driving cycles: <ul style="list-style-type: none"> UDDS NEDC
[49]	2016	R&D department, Otokar automotive and defense industry corporation, Arifiye, Sakarya, Turkey	<ul style="list-style-type: none"> Control the power flow from sources Observation of battery responses to the current changes and the effect of charging or discharging rate 	Three stages of operation: <ul style="list-style-type: none"> First stage determines whether the mode is charging or discharging In second stage, SOC level is observed to introduce a new weighting parameter Last stage introduces the power split rules considering SOC level and operating mode. 	Two driving cycles: <ul style="list-style-type: none"> Manhattan (low-speed transit bus operation) UDDSC (high speed bus operation)

validated using MATLAB/Simulink software. The simulation result shows a stable DC operating voltage and enhanced battery life. It considers two operating modes: motor mode and regenerative braking mode. The strategy follows energy conversion law like other strategies, and the load power P_{load} can be expressed as

$$P_{load} = P_{bat} + P_{sc} \tag{24}$$

$$P_{load} = \frac{1}{\eta} F_{te} v \tag{25}$$

where, η is the system efficiency, F_{te} is the total tractive effort, v is the vehicle speed. The schematic diagram of the proposed control scheme is represented in **Figure 11(a)**. The mentioned two strategies are compared in Table 7.

6) PARTICLE SWARM OPTIMIZATION (PSO)-BASED STRATEGY

A significant EMS-based PSO algorithm is proposed in [52] that ascertains the optimal power flow between

sources. ECE-15 urban driving cycle is tested using MATLAB/Simulink and justifies battery/UC SOC and power distribution requirements. The PSO is a randomized scheme that is influenced by the behavior of fish schooling and bird flocking, and all follow the relation as presented below.

$$Vel_i^d(t+1) = wVel_i^d(t) + C_1R_1(t)(p_{best}^d(t) - p_i^d(t)) + C_2R_2(t)(g_{best}^d(t) - p_i^d(t)) \tag{26}$$

$$p_i^d(t+1) = p_i^d(t) + Vel_i^d(t+1) \tag{27}$$

where, $Vel_i^d(t+1)$ is the particle velocity, p_i^d is the particle's position, w is the weighted factor, C_1, C_2 are the acceleration coefficients and R_1, R_2 presents the random variables.

7) FREQUENCY VARYING FILTER STRATEGY

The frequency varying filter strategy is presented in [53], which reduced scale approach aims to confirm the efficient power distribution between the sources by constructing a

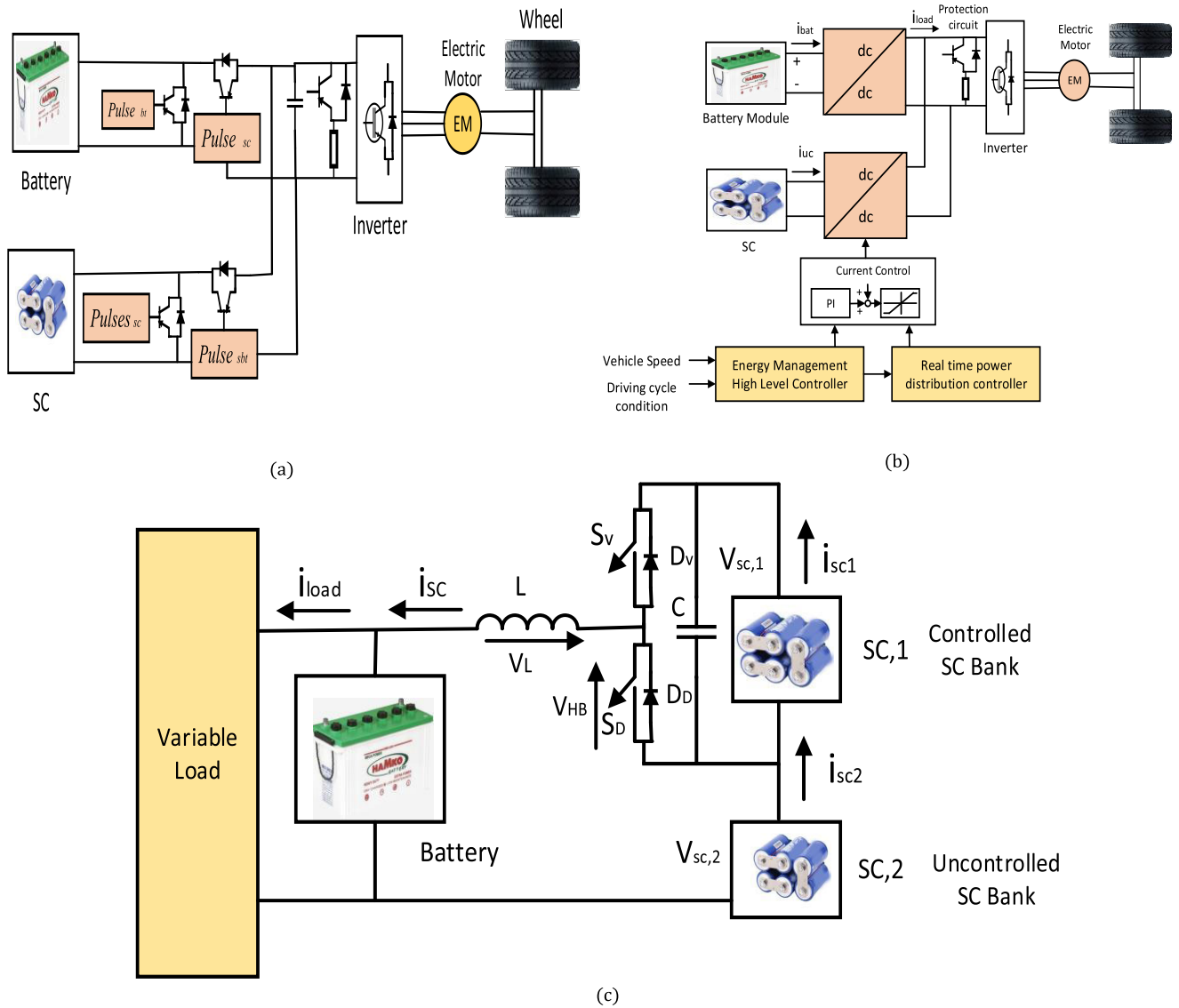

FIGURE 11. Representation of schematic diagram of battery-SC hybrid vehicle for (a) a power management strategy [51] (b) Frequency varying filter strategy [53] (c) Current control and filter decoupling technique based control strategy [54].

TABLE 7. Comparison among two existing control strategies for Battery-UC HESSs proposed in Ref. [50] and [51].

Ref	Year	Institution	Objective	Control Aspect	Operating Condition
[50]	2011	Chrysler Group LLC, Auburn Hills, MI 48326 USA	<ul style="list-style-type: none"> HEV costing Monitor and utilize the battery and UC responses at different conditions Efficacy in driving under low temperature condition 	<ul style="list-style-type: none"> A small dc/dc converter is employed to maintain the voltage level as $V_{UC} > V_{bat}$ 	Four modes of operation: <ul style="list-style-type: none"> Vehicle low constant speed operation Vehicle high constant speed operation Acceleration Deceleration
[51]	2017	Automatic Laboratory (LAS), Faculty of Technology, Setif-1-University, Setif, Algeria	<ul style="list-style-type: none"> Efficient energy distribution considering SOC level and vehicle displacement states Effect of UC on Battery lifetime 	<ul style="list-style-type: none"> Two bidirectional dc/dc converter is connected to the sources 	Two operating modes: <ul style="list-style-type: none"> Motor mode Regenerative Braking mode

three-layer EMS. There exist different operating modes: normal mode, charge mode, regenerative mode, and error mode. The three-layer EMS provides a chopper level controller,

power-sharing controller, and energy state controller. The process simulated by MATLAB/Simulink enables the SC to supply transient power and confirm the fast responses.

Figure 11(b) illustrates the schematic representation of the proposed strategy.

8) CURRENT CONTROL AND FILTER DECOUPLING TECHNIQUE-BASED CONTROL STRATEGY

A simplified power management strategy is proposed in [54] based on current control and a filter decoupling technique that confirms the battery to be less stressed and enables the SC to respond at the fast dynamic condition like acceleration, deceleration. This control scheme can involve FLC or neural network for complex implementation. The schematic representation of the control strategy is presented in Figure 11(c). This strategy uses a half-controlled controller and the ECE-15 European driving cycle. $\frac{1}{\tau}$ is considered as the decoupling frequency, and t_{max} is the time to achieve maximum discharge current. The range of decoupling frequency in this approach is considered by the following Eqn. (28).

$$\frac{2.2}{t_{max}} < \frac{1}{\tau} < \frac{2.2}{0.1t_{max}} \quad (28)$$

9) FUZZY LOGIC-BASED CONTROL STRATEGY

A real-time EMS is presented in [55], which is composed of FLC and filtering that intends to sustain the battery’s peak current at a reference level and keep up the stable voltage of UC. Three different driving cycles are introduced to continue the action: The new European driving cycle (NEDC), the Highway driving cycle (HWDC), and the Indian urban driving cycle (IUDC). The experimental outcome exhibits a controlled SOC of SC and a stable dc operating voltage.

Another FLC-based EMS is presented in [56], which aims to monitor the power fickleness under load variation. This approach considers SOC of battery instead of UC and takes appropriate steps following the change of SOC. The system is simulated using Simulink environment and shows the characteristics under various changes. The system has three inputs and one output. The proportion coefficient of battery power can be expressed as

$$K_{bat} = \frac{P_{bat}}{P_{req}} \quad (29)$$

where P_{req} is the required power of the load and P_{bat} presents the supplied power of the battery. The schematic representation of the proposed FLC-based EMS is demonstrated in Figure 12.

The comparison of the two existing FLC strategies is presented in Table 8.

10) FASTER JOINT CONTROL STRATEGY

A faster joint control strategy is proposed in [57] that exhibits a photovoltaic-based DC grid system that intends to govern the effective power drift through various sources compared to conventional methods. The experiment is tested on a small scale and a large scale platform and is implemented in the MATLAB environment. This process aims to reduce the

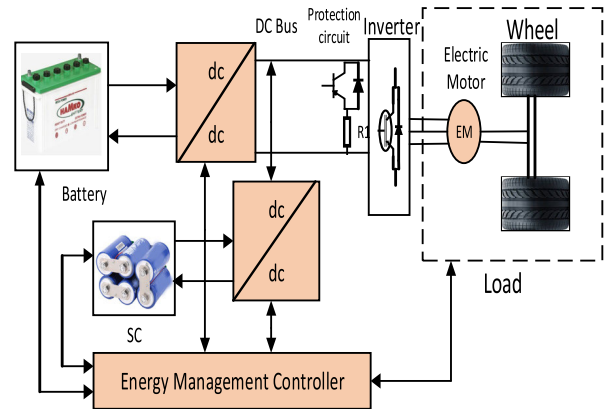

FIGURE 12. Representation of schematic diagram of battery-SC hybrid vehicle for fuzzy logic based control strategy [56].

battery’s pressure with long battery life and quickly respond. The total power flow in the DC-link is expressed as

$$P_l(t) - P_{ren}(t) = P_b(t) + P_{sc}(t) = P_{avg} + P_{tran} \quad (30)$$

where $P_l(t)$, $P_{ren}(t)$, $P_b(t)$, $P_{sc}(t)$ represents the load power, renewable energy source power, battery power, and SC power, respectively. P_{avg} is the average power and P_{tran} presents the transient power.

$$P_{avg}(t) + P_{tran}(t) = v_{dc}i_{tot} \quad (31)$$

The total current $i_{tot}(t)$ can be represented as

$$\begin{aligned} i_{tot}(t) &= i_{avg}(t) + i_{tran}(t) \\ &= K_{p_vdc}v_{er} + K_{i_vdc} \int v_{er}dt \end{aligned} \quad (32)$$

where K_{p_vdc} and K_{i_vdc} present the proportional and integral constants of the voltage control loop. v_{er} , v_{dc} and v_{ref} present the error voltage, dc-link measured voltage, and DC-link reference voltage, respectively. Figure 13 (a, b) represents the schematic representation of the proposed control strategy.

11) RULE BASED AND MPC BASED CONTROL STRATEGY

A system that combines both the rule-based control and the model predictive control is proposed in [58], focusing on the favorable power economy and enhancing battery lifetime. When the power requirement is significant, and sources have much energy, the MPC is employed. Otherwise, rule-based control is applied. There are three driving cycles: ECE cycle, UDDS cycle, and HWFET cycle to run the experiment. The MATLAB simulation platform is used to justify the proposed requirements.

12) OTHER CONTROL STRATEGIES

An effective way of controlling the power flow between sources and loads is proposed in [59] to lessen the estimation cost. A half-bridge topology is designed to run the experiment. Frequency division between high and low demonstrates

TABLE 8. Comparison between two existing fuzzy logic based control strategies for Battery-UC HESSs.

Ref.	Year	Institution	Objective	Control Aspect	Operating Condition
[55]	2019	The school of automobile and traffic engineering, Liaoning university of technology, Jinzhou, China	<ul style="list-style-type: none"> Real-time EMS 	<ul style="list-style-type: none"> Utilize filtering and FLC An appropriate battery fade model that can observe different battery characteristics 	Three standard driving cycles: <ul style="list-style-type: none"> NEDC HWDC IUDC
[56]	2016	Ningbo institute of technology, Zhejiang University, Ningbo	<ul style="list-style-type: none"> Improving the efficiency Considers only the battery SOC 	<ul style="list-style-type: none"> Two bidirectional dc/dc converter at each source FLC 	Two modes of operation for each of the controller: <ul style="list-style-type: none"> Buck mode Boost mode

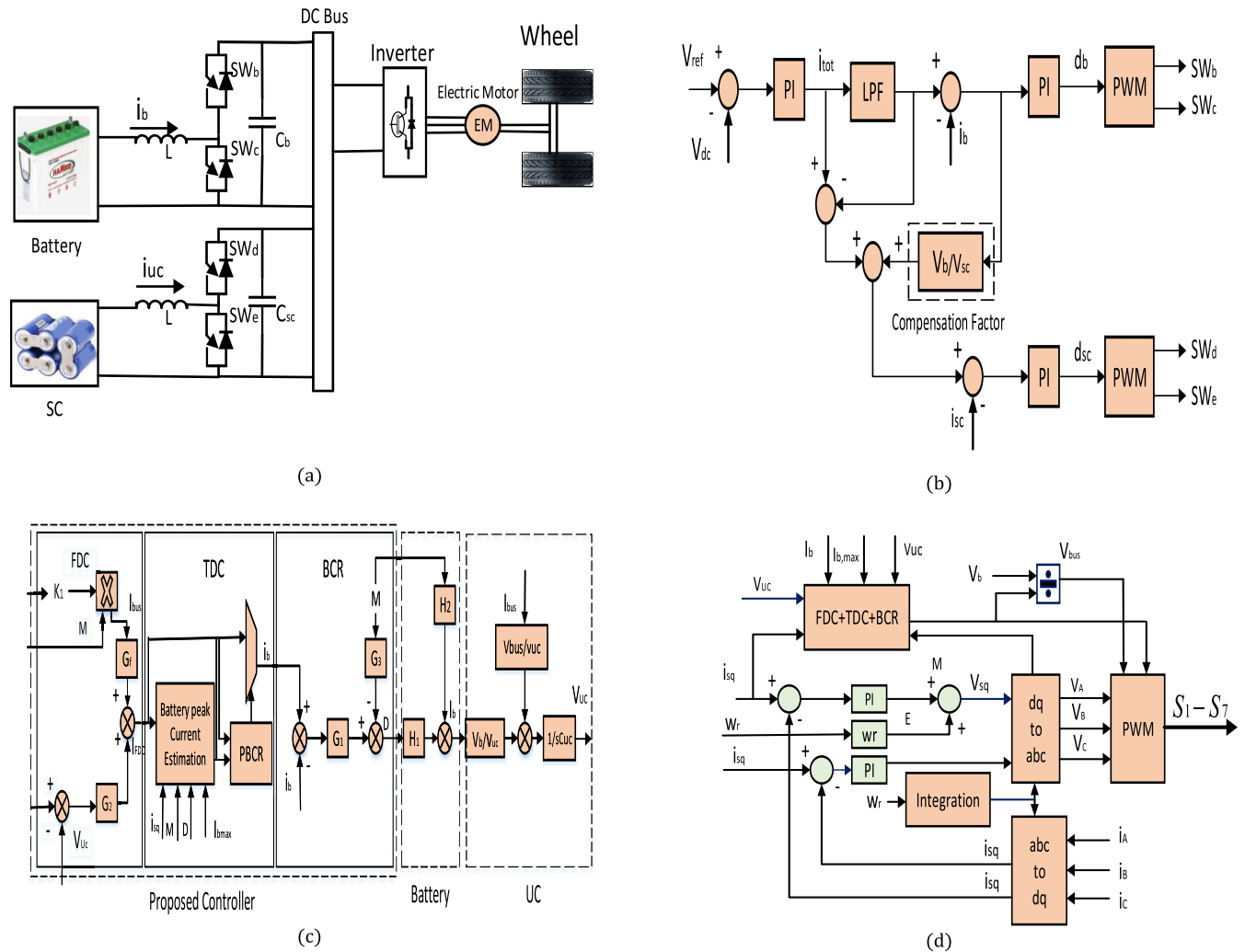

FIGURE 13. Representation of schematic diagram of battery-SC hybrid vehicle for (a) and (b) Faster joint control strategy [57], (c) & (d) Quasi-Z-Source Topology [60].

that high frequency is attenuated and hence enlarges the battery lifetime. Again the output voltage can be well regulated.

Again, a quasi-Z-source topology is presented in [60] that emphasizes the appropriate power distribution between sources under various operating conditions. This process implies three modes: traction mode, where the battery and UC supply power to the motor; regenerative mode, where

the inverse process of traction mode occurs and UCs energy recovery method, where battery supplies power to the UC and motor. To improve the efficiency of the proposed topology, the total shoot-through current I_{st} is computed as

$$I_{st} = \frac{P_0}{V_{UC}} \left[2 - \left(2 + \frac{V_{UC}}{V_b} \right) \frac{P_b}{P_0} \right] \quad (33)$$

where P_0 and P_b are the output power and battery power, respectively. The schematic representation of the proposed scheme is illustrated in **Figure 13 (c, d)**.

The average shoot-through current of the switches in each leg be

$$I_{avss} = - \left[\left(2 + \frac{V_{UC}}{V_b} \right) \frac{P_0}{3V_{UC}} \right] k_{power} + \frac{2P_0}{3V_{UC}} \quad (34)$$

K_{power} is the power division ratio and can be described as

$$K_{power} = \frac{P_b}{P_0} \quad (35)$$

The range of I_{avss} can be represented as

$$|I_{avss}| \leq \frac{2P_0}{3V_{UC}} \quad (36)$$

Again, reference [61] presents a strategy considering components sizing, energy consumption, and battery lifetime. To minimize the global losses of the process, the current $i_{h_batt_ref}$ is computed.

$$i_{h_batt_ref} = \frac{i(R_{scp} + R_{L2})U_{batt_0}^2}{(R_{batt} + R_{L1})U_{scp_0}^2 + (R_{scp} + R_{L2})U_{batt_0}^2} \quad (37)$$

where R_{batt} , R_{scp} are the equivalent resistance, R_{L1} and R_{L2} are the resistance of inductances L_1 and L_2 respectively. U_{batt_0} and U_{scp_0} present the voltage sources.

Vehicle acceleration strategy implies the estimation of acceleration for proper functioning. This strategy determines the traction force F_{tract} which is the combination of global resistive force F_{res} and vehicle acceleration force F_{acc} .

$$F_{tract} = F_{acc} + F_{res} \quad (38)$$

where $F_{acc} = Ma_{veh}$

$$P_{tract} = P_{acc} + P_{res} \quad (39)$$

where $P_{acc} = v_{veh}F_{acc}$

$$P_{res} = v_{veh}F_{res} \quad (40)$$

M is the mass, v_{veh} is the velocity and a_{veh} presents the acceleration of the vehicle.

The filtering strategy emphasizes the cutoff frequency. The variable saturation current approach limits the power flow through the battery that influences the overall performance. Each of the methods is evaluated in ECE urban driving cycle and implemented using MATLAB/Simulation environment.

The overall comparison among different control strategies for batter-UC configuration is presented in Table 9. The advantages and disadvantages of different control strategies for this configuration are represented in Table 10.

B. CONTROL STRATEGIES FOR FC-BATTERY HYBRID ENERGY SYSTEMS

1) NOVEL RANGE EXTENDED STRATEGY

A novel range-extended strategy is demonstrated in [62]. The process is based on increasing the battery SOC to lessen vehicle drivers' anxiety. The FLC is introduced, which prevents

the rapid diminution of battery SOC and eventually increases the battery SOC. An urban driving cycle (four ECE-15) is applied to examine the approach. The implementation is continued via the MATLAB/Simulink platform, which achieves a spiffy performance in battery SOC and fuel consumption. **Figure 14(a)** presents the schematic representation of the proposed control scheme.

2) OPTIMAL DIMENSIONING AND POWER MANAGEMENT STRATEGY

An optimal dimensioning and power management strategy is represented in [63]. This approach applies convex programming to improve the optimal power management and component sizing of the HEVs. ADVISOR is used as a simulation platform at different driving conditions: 1. Standard Manhattan bus cycle 2. Standard city-suburban cycle and 3. A real bus line cycle. This concept shows a better fuel economy and component size maintenance.

3) POWER MANAGEMENT AND DESIGN OPTIMIZATION STRATEGY

Power management and design optimization strategy are presented in [64]. It is a sub-system scaling model that ensures optimal power management between sources. Stochastic dynamic programming (SDP), which considers battery SOC, is applied at the beginning of the experiment, and due to some limitations, a Pseudo SDP controller is used. The test is verified in three different driving cycles: FTP-72, HWFET, and ECE-EVDC and demonstrates a good fuel economy. The schematic representation of the proposed control strategy is demonstrated in **Figure 14(b)**.

4) OPTIMAL VALUE CONTROL STRATEGY

An optimal value control strategy is introduced in [65], based on a Time-Triggered Controller Area Network (TTCAN). It combines both the equivalent consumption minimization strategy (ECMS) and the braking energy regeneration strategy (BERS). TTCAN recognizes real-time problems and can figure out the solution. This scheme was successfully applied at the Beijing Olympic Games of 2008 and tested at 'China city bus typical cycle.' ECMS and BERS ensure better fuel economy than other strategies, and also BERS achieves more than ECMS.

5) RULE-BASED ENERGY MANAGEMENT STRATEGY

A rule-based energy management strategy is demonstrated in [39] that comprises a classical PI control and focuses on reducing fuel consumption. MATLAB/Simulink simulation platform is applied in the European urban cycle ECE-15. Three different modes are available: stop mode, traction mode, and braking mode. **Figure 14(c)** illustrated the schematic diagram of the proposed EMS.

6) POWER STRATEGY FOR HYBRID LOCOMOTIVE SYSTEM

A power strategy for a hybrid locomotive system is presented in [66]. This strategy proposes a locomotive system that

TABLE 9. Comparison among different control strategies for Battery-UC configuration.

Ref.	Year	Control Strategy	Institution	Simulation Platform	Exp. Validation	Exp. Platform
[41]	2020	A modified semi-active topology	Central Mechanical Engineering Research Institute, Durgapur, India	MATLAB/Simulink	Yes	A scaled-down bidirectional converter with its control logic validated through the dSPACE 1103 controller board
[42]	2020	Efficient MPC	College of Information Engineering, Zhejiang University of Technology, Hangzhou, China	MATLAB/Simulink	Yes	Not Indicated
[43]	2014	MPC	The University of New South Wales Sydney, Australia	MATLAB/Simulink, Real-time workshop software	Yes	Not Indicated
[44]	2019	Dynamic simulation of Battery/SC HESS	Natural Resources Canada	Simscape power system in MATLAB/Simulink and ADVISOR	Yes	Tesla S70 electric car
[45]	2018	A real-time energy management control strategy	Laboratory of Electrical Engineering and Power Electronics, University of Lille, Villeneuve d'Ascq, France	dSPACE based Autobox	Yes	30kW rated power HESS, Three standard driving cycle NEDC, HWDC, IUDC
[46]	2019	An improved real-time power-split control strategy	SSN College of Engineering, Kalavakkam, India	MATLAB/Simulink	Yes	Small scale experiment platform
[47]	2019	Real-time control strategy	ShanghaiTech University, Shanghai 201210, China	ADVISOR	Yes	Scaled-down bench test
[48]	2016	Rule-based EMS	State key laboratory of automotive simulation and control, Jilin University, China	dSPACE based MicroAutoBox (DS1401)	Yes	Two standard drive cycle for an electric vehicle
[49]	2016	A rule-based power split strategy	R&D department, Otokar automotive and defense industry corporation, Arifiye, Sakarya, Turkey	MATLAB/Simulink	Yes	Hybrid electric city bus under different drive cycle
[50]	2011	A new Battery/UC Hybrid Storage System	Chrysler Group LLC, Auburn Hills, MI 48326 USA	PSAT software, Modeling of hysteresis regulated by MATLAB/Stateflow	Yes	A scaled-down experimental setup
[51]	2017	A new strategy for Battery/SC energy management	Automatic Laboratory (LAS), Faculty of Technology, Setif-1-University, Setif, Algeria	MATLAB/Simulink	Yes	An urban EV movement
[52]	2019	A significant energy management control strategy	SRM Institute of Science and Technology, India	MATLAB/Simulink	Yes	ECE-15 urban driving cycle
[53]	2013	Frequency varying filter strategy	Graduate School of Frontier Sciences, the University of Tokyo	dSPACE with MATLAB/Simulink	Yes	Reduced scale power train system
[54]	2012	A simplified power management strategy	Department of Advanced Energy, The University of Tokyo, Japan	Not Indicated	Yes	A DC motor simulating ECE-15 (European Driving cycle) pattern

TABLE 9. (Continued.) Comparison among different control strategies for Battery-UC configuration.

[55]	2016	Fuzzy energy management control	Ningbo institute of technology, Zhejiang University, Ningbo	MATLAB/ Simulink	Yes	Not Indicated
[57]	2018	Faster joint control strategy	Nanyang Technological University, Singapore	dSPACE 1103 real-time controller	Yes	PV system with HESS
[58]	2019	Rule and MPC based hybrid electric allocation system	Ningbo Institute of Technology, Zhejiang University, China	MATLAB/ Simulink	Yes	HEV Exp. Platform by three typical cycles: ECE cycle, UDDS cycle, and HWFET cycle
[59]	2020	Control strategy for Battery/UC HESS	Velalar College of Engineering and Technology, India	Half-bridge topology(also called bidirectional boost or buck-boost), signal generator, oscillator	Yes	Analog devices 16 bit DSP (ADSP-21992)
[60]	2016	HESS based on Quasi-Z-source topology	The College of Electrical Engineering, Zhejiang University, China	Not Indicated	Not Indicated	Short time scale
[61]	2010	Different energy management strategy of HESS	Univ. Lille Nord de France, France	MATLAB/ Simulink	Not Indicated	4 ECE urban driving cycle

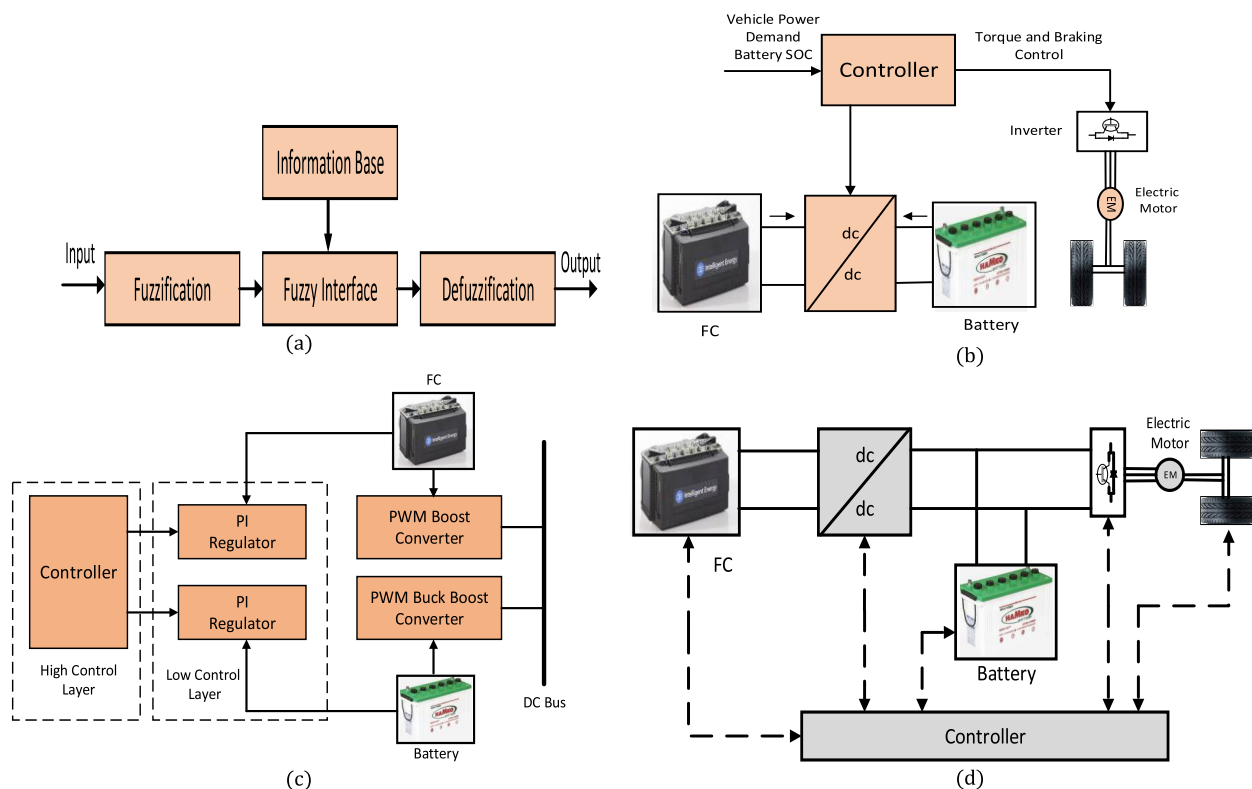

FIGURE 14. Representation of schematic diagram of FC-battery HEV that utilized (a) Fuzzy control block for novel range extend strategy [62], (b) Power management and design optimization strategy [64] (c) Rule based energy management strategy [39], and (d) Power strategy for hybrid locomotive system [66].

is tested using two different techniques: power following strategy (PFS) and fuzzy logic power management strategy (FMS). The basic idea of the locomotive system is to

achieve the minimization of fuel consumption and dynamic responses. The PFS method is first applied in different driving cycles, and then the FMS is introduced to justify the

TABLE 10. Advantages and limitations of the mentioned control strategies for Battery-UC configuration.

Ref.	Control Strategy	Advantages	Limitations
[41]	A modified semi-active topology	<ul style="list-style-type: none"> Countering inrush of high fluctuating currents Ensures DC-link stability compensating the inductor current UC responds to peak power demand to maintain an efficient operation Minimizes cost and maximizes efficacy 	<ul style="list-style-type: none"> Diode faults result in an undesirable backflow of power Large duty ratio causes irregular switching pulse Instability in converter
[42]	Efficient MPC	<ul style="list-style-type: none"> SC responds effectively during the peak power demand Attains efficient outcomes with a longer prediction horizon The battery charges SC to maintain an average SC SOC level during the low level of SC SOC 	<ul style="list-style-type: none"> Less prediction accuracy High computational load The increment of ampere-hour affects the degradation of the battery
[43]	MPC	<ul style="list-style-type: none"> Follows specified constraints to maintain optimal operation Participates in an extensive power system compensating the power components 	<ul style="list-style-type: none"> The response of battery in only slow current changes Generation of current harmonics due to failure in the operation of inductors Lack of required current due to insufficient power storage
[44]	Dynamic simulation of battery/SC HESS	<ul style="list-style-type: none"> SC supplies transient current to reduce stress from the battery Optimal sizing of the EV system Performs efficiently in different driving cycles Lessens the probability of catastrophic failure 	<ul style="list-style-type: none"> Undesirable battery SOC decrement for temperature range -20°C to 30°C
[46]	Improved real-time power-split EMS	<ul style="list-style-type: none"> Reduction of RMS current of the battery Effective exploitation of UC Enhancement in the lifespan of the battery Employment of lead-acid batteries for non-feasibility 	<ul style="list-style-type: none"> Increases cruising power of the motor Increases speed constant Non-feasibility of lead-acid batteries
[47]	Real-time control strategy	<ul style="list-style-type: none"> Lower computation complexity with higher speed Much smoother battery pack current Minimized battery current magnitudes and ripples Stabilizes dc-link voltage and improves the dynamic response Utilizes UC bank as the energy buffer Easy implementation in real-time No requirement of pre-information of future load demand 	<ul style="list-style-type: none"> Rise in error with imperfect weight set Quite time-consuming calculation due to convex programming
[48]	Rule-Based EMS	<ul style="list-style-type: none"> Extends battery lifetime Provides voltage stability and avoids significant voltage drop for battery Solves the battery potential balancing problem Enhances storage capacity 	<ul style="list-style-type: none"> Battery current ranges from -20 A to 20 A Low battery depth of discharge (DOD) Limitation in electric vehicle range Absorption of more braking energy resulting in lower system efficiency
[49]	Rule-Based Power Split Strategy	<ul style="list-style-type: none"> Reasonable solutions being offered to the power split problems in HEVs for their flexibility and robustness. Less exposed battery to rapid current changes and high charge/discharge rates The current drawn from the battery becomes much smoother during sudden acceleration 	<ul style="list-style-type: none"> Use of weighting parameters A narrow band of energy for battery source
[50]	New Battery/UC HESS	<ul style="list-style-type: none"> Utilizes the UC power responses Provides an accessible platform for the battery by lessening power demand Reduces current requirement for vehicle Excellent driving capability in low temperatures 	<ul style="list-style-type: none"> Fluctuations in dc-link voltage Illustrates a complex HESS Less cost-efficient

TABLE 10. (Continued.) Advantages and limitations of the mentioned control strategies for Battery-UC configuration.

[51]	A new strategy for Battery and SC EMS	<ul style="list-style-type: none"> • Enhances EV capability at deceleration phase • Prolongs battery lifetime • Ensures a proper distribution of power among sources • Facilitates from the regenerative braking mode • Expands EV operating range 	<ul style="list-style-type: none"> • Increased number of components • Undesirable speed increment with acceleration
[52]	A significant EMS	<ul style="list-style-type: none"> • Optimal power distribution among sources • The combination of Battery and SC presents a proper energy sharing platform with high efficiency 	<ul style="list-style-type: none"> • Time-consuming due to iteration based performance
[53]	EMS based on the frequency varying filter	<ul style="list-style-type: none"> • Enhances system efficiency by utilizing the current flow • Assists EV system to control cut-off frequency in a suitable range • Utilizes SC bank and improves frequency varying capability 	<ul style="list-style-type: none"> • A complex energy management strategy • The slow dynamics of battery power
[54]	A simplified power management strategy	<ul style="list-style-type: none"> • Simple and cost-efficient • UC supports the battery in discharge mode for a specific limit 	<ul style="list-style-type: none"> • Pre-charging is necessary to the current control • A regulator is required for control purposes
[56]	FLC based EMS	<ul style="list-style-type: none"> • Stable DC bus voltage during load change • Limited current variation in battery • High reliability, high efficiency, good dynamics • Simple and effective charging-discharging performance • Minimized circulation of the high-frequency component through the supplies • Extended lifetime and high power density 	<ul style="list-style-type: none"> • Restriction in the number of input variables • Lower speed • Extended run time of system • The requirement of higher fuzzy grades for higher accuracy leading to an exponential increase in rules
[57]	Faster joint control strategy	<ul style="list-style-type: none"> • Stores DC-link voltage as fast as possible • Prolongs battery lifetime • Reduces battery stress utilizing UC • Batter dynamic performance and efficiency compared to others 	<ul style="list-style-type: none"> • Inefficient in transient response for a short time • Instability arises due to inappropriate switching frequency
[58]	Rule and MPC based hybrid energy	<ul style="list-style-type: none"> • Reduction of energy loss • Lessens power loss and improves EMS efficiency. • Maintains motor speed and torque at a feasible range considering driving cycles 	<ul style="list-style-type: none"> • Difficulties with operation • High maintenance cost • Lack of flexibility
[59]	Control Strategy for Battery-UC-based HESS	<ul style="list-style-type: none"> • Stable output voltage • Lessens discharge rates • Eliminates high-frequency current • Prolongs battery lifetime 	<ul style="list-style-type: none"> • Resistive load does not permit the EMS to follow driving cycles
[60]	Quasi-Z-Source topology and enhanced frequency driving coordinated control	<ul style="list-style-type: none"> • Improves the dynamic power distribution • UC responds effectively during the transient response and assists battery • Less battery requirement and elimination of the corresponding dc-dc converter • Provides independent power routines for sources 	<ul style="list-style-type: none"> • Complex system • Negligence in system power loss
[61]	Different energy management strategy of HESS	<ul style="list-style-type: none"> • Introduces a distribution coefficient method to activate inversion-based control • Ensures optimal sizing • Prolongs battery lifetime 	<ul style="list-style-type: none"> • Considering similar batteries in two vehicles is not possible • The width of the window for calculation influences the system efficiency

requirements. The whole process’s implementation is evaluated using ADVISOR software and MATLAB/Simulink environment. The simulation results in a comparative analysis between the two control units and shows a better FMS

performance. **Figure 14(d)** presents the schematic diagram of the power control strategy.

Table 11 presents the relative analysis of different control strategies for FC-battery configuration.

TABLE 11. Comparison among the above-mentioned control strategies for FC-Battery configuration.

Ref.	Control Strategy	Simulation Platform	Exp. Validation	Advantages	Disadvantages
[39]	Rule-based EMS	MATLAB/Simulink	Yes	<ul style="list-style-type: none"> • Effective over the entire operating range of the vehicle based on performance and fuel economy • Minimized fuel consumption • SOC in an acceptable functioning area 	<ul style="list-style-type: none"> • No information about the driving cycle for the lower control layer • Chance of abrupt voltage drop.
[62]	Novel range extended strategy	MATLAB/Simulink	No	<ul style="list-style-type: none"> • Improves system's fuel economy • Avoid continuous deep discharge of the battery. • Enhances battery lifetime 	<ul style="list-style-type: none"> • Uneconomic compensation of the loss of battery SOC
[63]	Optimal dimensioning and power management strategy	ADVISOR (Advanced Vehicle Simulator)	Yes	<ul style="list-style-type: none"> • Illustrates an optimal sizing of EMS • Enhances system efficiency • Optimal battery sizing and fuel economy 	<ul style="list-style-type: none"> • Limitations on battery constraints • Challenges to control battery SOC • FC insensitiveness
[64]	Power management and design optimization strategy	FC-VESIM (FC Hybrid Vehicle Simulator)	Yes	<ul style="list-style-type: none"> • Optimal power management of FC in the specified limit • Minimizes cost and maximizes efficiency • Considers different operating cycles to test the SOC sensitivity 	<ul style="list-style-type: none"> • Undesirable battery capacity • Reduces fuel economy as battery capacity decreases
[65]	Optimal value control strategy	Not Indicated	Yes	<ul style="list-style-type: none"> • Economic hydrogen consumption than others • Utilizes the facilities of event and time-triggered communication • Quasi deterministic behavior with the possibility of easy realization of fault-tolerant systems as a merit of TTN 	<ul style="list-style-type: none"> • Complexity in the designing process • Communication structure is needed to be pre-defined
[66]	FLC strategy for hybrid locomotive system	ADVISOR and MATLAB/Simulink	Yes	<ul style="list-style-type: none"> • Presents robustness in operation • Illustrates an efficient dynamic performance in the hybrid locomotive system 	<ul style="list-style-type: none"> • Limits FC output power to a specified range
[67]	Optimized EMS	MATLAB/Simulink	Yes	<ul style="list-style-type: none"> • Permitting the vehicle to run or stop at the most suitable SOC • Maintenance of car battery at an appropriate SOC value for reduction of the gas fuel usage 	<ul style="list-style-type: none"> • Optimal only when the destination is known

C. CONTROL STRATEGIES FOR FC-UC HYBRID ENERGY SYSTEM

1) ENERGY SHARING STRATEGY

An energy sharing strategy is presented in [68]. A small-scale experiment considering FC as the primary source and SC as the secondary source is recommended in this approach. This process concerns maintaining DC voltage at a specific limit. The FC operates at steady-state conditions while SC delivers peak power in the transient situation. An implementation is done to validate this process for only an FC with the DC bus, and another is done for FC and SC. MATLAB/Simulink and ControlDesk software are included as the simulation platform of this approach.

2) NON-LINEAR CONTROL STRATEGY

A nonlinear control strategy is illustrated in [69]. This nonlinear control is suggested using two sources: FC and SC, to control hybrid electric power systems under the desirable

power supply. The proposed method introduces the Lyapunov stability design techniques for the nonlinear analysis of the system. The study is authenticated in a numerical simulation platform using MATLAB software. Simulation in a controlled regulation of DC operating voltage and SC reference current and the system stability. The schematic representation of the control strategy is illustrated in **Figure 15(a)**.

3) ENERGETIC MICROSCOPIC REPRESENTATION (EMR) AND INVERSION BASED CONTROL

An EMR and inversion-based control is presented in [70]. This strategy proposes an inversion-based small-scale test platform using EMR techniques. It provides better conduct compare to the classical approaches because it considers saturation management. The SOC of UC at low and high states is taken into account to ensure proper power management. EMR, a graphical descriptive tool, presents smooth power distribution from sources under load changes, and the

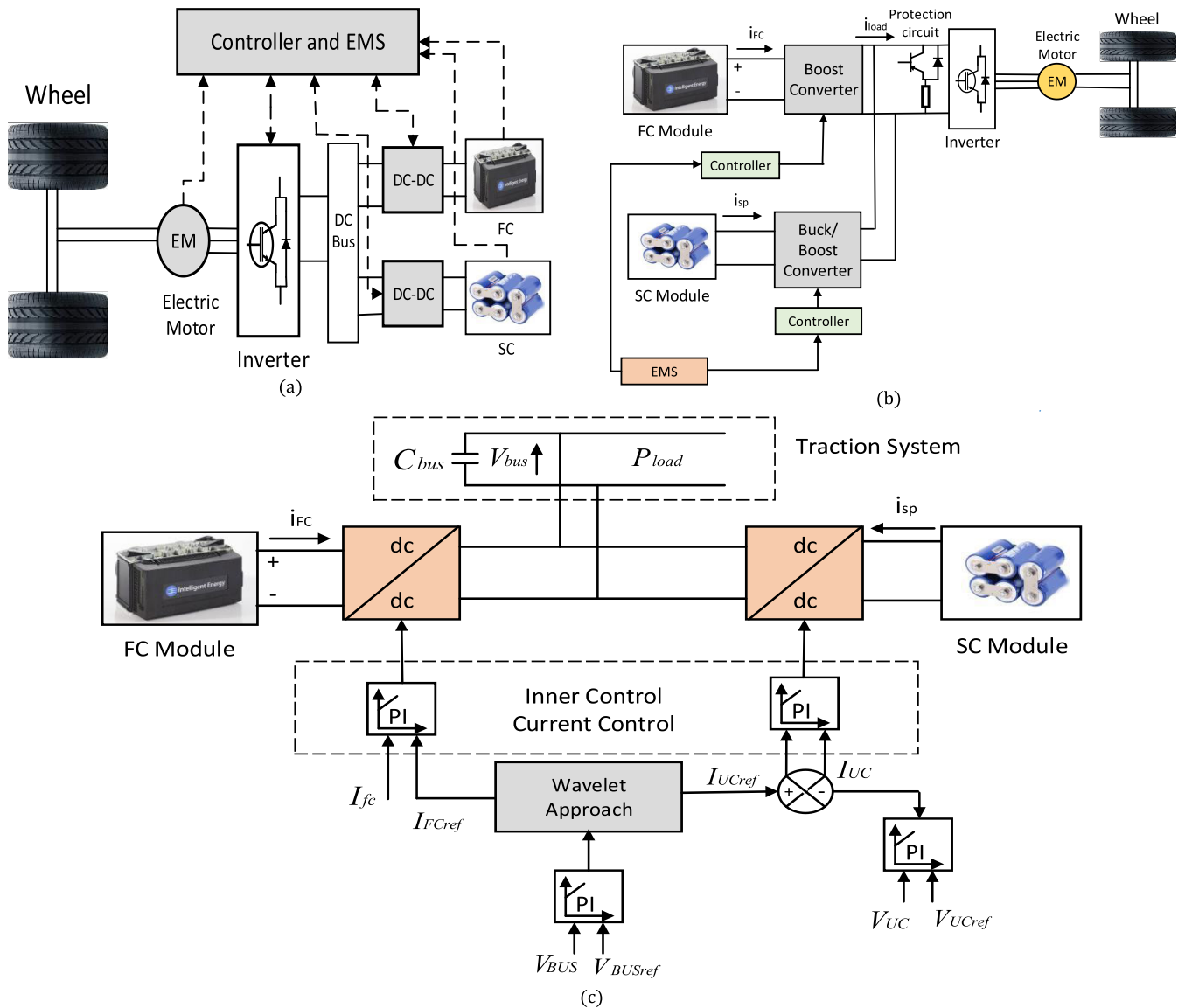

FIGURE 15. Representation of schematic diagram of FC-SC hybrid vehicle for (a) Non-linear control strategy [69], (b) Power management and hydrogen economy based strategy [71] (c) Wavelet approach based energy management strategy [72].

analysis is corroborated using MATLAB/Simulink environment showing a reliable and efficient method.

4) POWER MANAGEMENT AND HYDROGEN ECONOMY BASED STRATEGY

An EMS is represented in [71] that focuses on power management and the hydrogen economy to reduce costs.

The driving cycle implies three modes: traction mode, steady speed mood, and braking mode. The simulation completed by MATLAB environment demonstrates an optimal hydrogen economy of FC and maintaining reference power constraints. The load power P_{load} is defined as

$$P_{load} = P_{fc} + P_{sc} \tag{41}$$

where P_{fc} and P_{sc} are the FC power and SC power, respectively. **Figure 15(b)** illustrates a schematic diagram of the proposed control strategy.

5) WAVELET APPROACH BASED ENERGY MANAGEMENT STRATEGY

An efficient EMS is given in [72] that includes a wavelet approach to ensure proper power distribution from sources. The schematic diagram of the proposed strategy is demonstrated in **Figure 15 (c)**. FC provides low power, whereas UC offers high power. The ECE-15 driving cycle and real driving cycle are introduced for the experimental simulation in MATLAB/Simulink, SimPowerSystem toolbox. This strategy contributes to a stable performance under load variations and can take stress under overload conditions. The load power

P_{load} can be expressed as

$$P_{load} = \eta_{FC}P_{FC}(t) + \eta_{UC}P_{UC}(t) \quad (42)$$

where η_{FC} and η_{UC} presents the efficiencies of converters of FC and UC, respectively.

$$P_{load} = V[C_r M g \cos(\alpha) + M g \sin(\alpha) + M \frac{dv}{dt} + \frac{1}{2} \rho s C_x V^2] \quad (43)$$

where C_r and C_x illustrates the friction and aerodynamic coefficients, respectively. ρ and s represents the air density and the front surface area, respectively. M is the mass, g is the gravity constant, and α is the slope angle. The continuous wavelet transform can be described as

$$CWT_x^\psi(\tau, s) = \psi_x^\psi(\tau, x) = \frac{1}{\sqrt{|s|}} \int x(t) \psi^*\left(\frac{t-\tau}{s}\right) dt \quad (44)$$

where τ and s are the translation and scale parameters, respectively. $\psi(t)$ is called the mother wavelet.

6) LINEAR AND SLIDING MODE CONTROL BASED STRATEGY

Linear and sliding mode control are presented in [73], showing a stable and smooth vehicle system under load changes. Sliding mode control is applied here to assure security and to facilitate power management. Three modes are defined to ascertain proper power management depending on the SC SOC and power demand as follows

$$\text{In normal mode, } I_{SC_{ref}} = I_{I_0} - I_{FC} \quad (45)$$

$$\text{In discharge mode, } I_{SC_{ref}} = I_{I_0} - I_{FC_{max}} \quad (46)$$

$$\text{In charge mode, } I_{SC_{ref}} = I_{I_0} + I_{FC_{max}} \quad (47)$$

where $I_{SC_{ref}}$ presents the reference current of the SC. MATLAB/Simulink is used as a simulation platform that confirms the required performances.

7) HYBRID EMS

A hybrid EMS is presented in [74]. This strategy implies three different methods: voltage control, average current control, and hybrid control, where hybrid control is the combination of the other two techniques. The voltage control method responds to the reference voltage under high-speed variations. The reference signal of the converter $V_{dc_{ref}}$ can be calculated as follows:

$$V_{dc_{ref}} = V_{dc_{max}} - \omega_m(K1) \quad (48)$$

$$\text{where } K1 = \frac{V_{dc_{max}} - V_{dc_{min}}}{\omega_{max}} \quad (49)$$

V_{dc} can be computed from

$$V_{dc} = \frac{1}{C} \int_0^t i_{sc} dt \quad (50)$$

Average current control maintains average power under slow speed variations. The average reference current I_{av} is derived

from

$$I_{av} = \frac{P_{av}}{V_{dclink_{av}}} \quad (51)$$

therefore

$$I_{av} = \frac{\int_0^t P_{instmech} dt}{\int_0^t V_{dclink} dt} \quad (52)$$

Hybrid control includes both control schemes and operates only one control scheme depending on low or high speed.

Table 12 represents a comparative analysis among different control strategies for FC-UC configuration.

D. CONTROL STRATEGIES FOR FC-BATTERY-UC HYBRID ENERGY SYSTEM

1) MPC

An MPC method for the FC-Battery-UC system is presented in [77]. With the ability to maintain the reference current to a specific range using a hysteresis control, this proposed control strategy provides flexibility and ensures energy efficiency. FC and battery act as the primary and secondary sources, respectively, while additional energy is provided by a UC that provides peak power during accelerating and braking of the HEV. This strategy, a feedback control system, focuses on utilizing the energy supplied by HES and maintaining a real-time solution for the optimization problem. DP, an effective tool for determining a dynamic system's optimal solution, presents advantages for the unconstrained MPC. A small-scale experiment is involved and validated in this control strategy. The whole process is implemented using MATLAB/Simulink software on a dSPACE platform representing responses to various changes. The process involved in this strategy results in an efficient energy management control strategy with excellent dc bus voltage regulation.

2) PARALLEL ENERGY-SHARING CONTROL STRATEGY

A parallel energy-sharing control strategy is demonstrated in [78] that concerns the proper energy management and power flow through the power sources. It is capable of maintaining the required power supply. The system is designed with six control loops for three reasons: maintaining proper DC voltage, state of charge of energy sources, and the current flow.

Each of the power sources is connected with the DC bus in a parallel manner. The system uses six control loops: three inner current control loops, a DC bus voltage control loop, a battery charge control loop, and a UC voltage control loop. UC can provide peak power requirements during the accelerating and braking situation of the electric vehicle. The battery can not respond to the peak power requirements like UC and operates at a safe range of power. This strategy is implemented using MATLAB/Simulink simulation environment to validate different conditions like start-up, acceleration, and deceleration. The simulation results in excellent responses to the vehicle's torque control and protects the FC and the battery from overstressed. Reference signals at each control

TABLE 12. Comparison among the above-mentioned control strategies for FC-UC configuration.

Ref.	Control Strategy	Simulation Platform	Exp. Validation	Advantages	Disadvantages
[69]	Nonlinear control Strategy	MATLAB/Simulink	Yes	<ul style="list-style-type: none"> Effectiveness in automotive applications Fulfills the specified control objectives Less information is required to compute the load current 	<ul style="list-style-type: none"> May suffer from the limit cycle, chaos, and bifurcation Lack of guarantee in global stability by most of the schemes Higher cost
[70]	EMR and Inversion Based Control	MATLAB/Simulink	Yes	<ul style="list-style-type: none"> Safe and efficient Limiting the current dynamics Utilizes FC current 	<ul style="list-style-type: none"> A slight decrease in UC SOC due to the loss effect UC is needed to handle the transient response
[71]	New EMS	STM32F4 to create the PIL block and MATLAB/Simulink	Yes	<ul style="list-style-type: none"> Robust and reliable Minimizes FC power demand Increased durability Minimized hydrogen consumption 	<ul style="list-style-type: none"> Significant switching loss due to the large PWM frequency Voltage spikes
[72]	Efficient EMS	MATLAB/Simulink	Yes	<ul style="list-style-type: none"> Efficient power distribution among loads FC voltage is free to respond to any sudden drop 	<ul style="list-style-type: none"> Inefficient performance from the discrete wavelet transform Requires additional energy to select an efficient one
[73]	Linear and sliding mode control	MATLAB/Simulink	Yes	<ul style="list-style-type: none"> Fast responses to the FC current Optimal power distribution among loads Stable and robust performance 	<ul style="list-style-type: none"> Very complicated to design. Dependence of performance of the controller heavily on the sliding surface Inappropriate design of the sliding surface leading to unacceptable performance
[74]	Voltage control	MATLAB/Simulink	Not Mentioned	<ul style="list-style-type: none"> Simple and linear Maintains a feasible operating platform with a smooth change in loads 	<ul style="list-style-type: none"> The current level should be maintained at a specific range to compute the maximum recovered power from loads
[74]	Averaged current control	MATLAB/Simulink	Not Mentioned	<ul style="list-style-type: none"> Easier in implementation Maintains power efficacy considering average power of FC 	<ul style="list-style-type: none"> Less efficient in open-loop control operation Permanent risk of overpassing V_{dclink} due to the absence of control Failure in case of high-speed demand for a more extended period
[74]	Hybrid method	MATLAB/Simulink	Not Mentioned	<ul style="list-style-type: none"> Easy to implement and linear Provides an opportunity to choose desired control scheme from the hybrid system Suggested in case of high-velocity changes in safe driving journeys 	<ul style="list-style-type: none"> Suggested in case of high-velocity changes in safe driving journeys Creates confusion to choose an optimal control scheme from the hybrid system
[75]	EMS for FC/SC	MATLAB/Simulink	Yes	<ul style="list-style-type: none"> Improved FC lifetime Minimized cost 	<ul style="list-style-type: none"> The average speed of 33.35km/h.
[76]	Hybrid EMS	Not Mentioned	Yes	<ul style="list-style-type: none"> UC lessens power stress during peak power demand Ensures proper distribution of power among loads Monitors load demand 	<ul style="list-style-type: none"> High starting overshoot of PI controller Sensitivity towards controller gains with a slower response to sudden disturbances

loop can be illustrated as below:

$$I_{FC\ ref} = I_{load} + I_{Batt-C} + I_{UC-C} \tag{56}$$

$$V_{bus\ ref} = constant \tag{53}$$

$$I_{UC\ ref} = I_{load} - (I_{FC\ feedback} + I_{Batt\ feedback}) + I_{UC-D} \tag{54}$$

$$I_{Batt\ ref} = I_{load} + I_{UC-C} - I_{FC\ feedback} \tag{55}$$

where $V_{bus\ ref}$ is the dc bus voltage, $I_{FC\ ref}$, $I_{UC\ ref}$ and $I_{Batt\ ref}$ present the current loop reference signals in the FC, UC, and Battery, respectively. $I_{FC\ feedback}$ and $I_{Batt\ feedback}$ presents the feedbacks current through the FC and battery, respectively. I_{load} presents the load current demand.

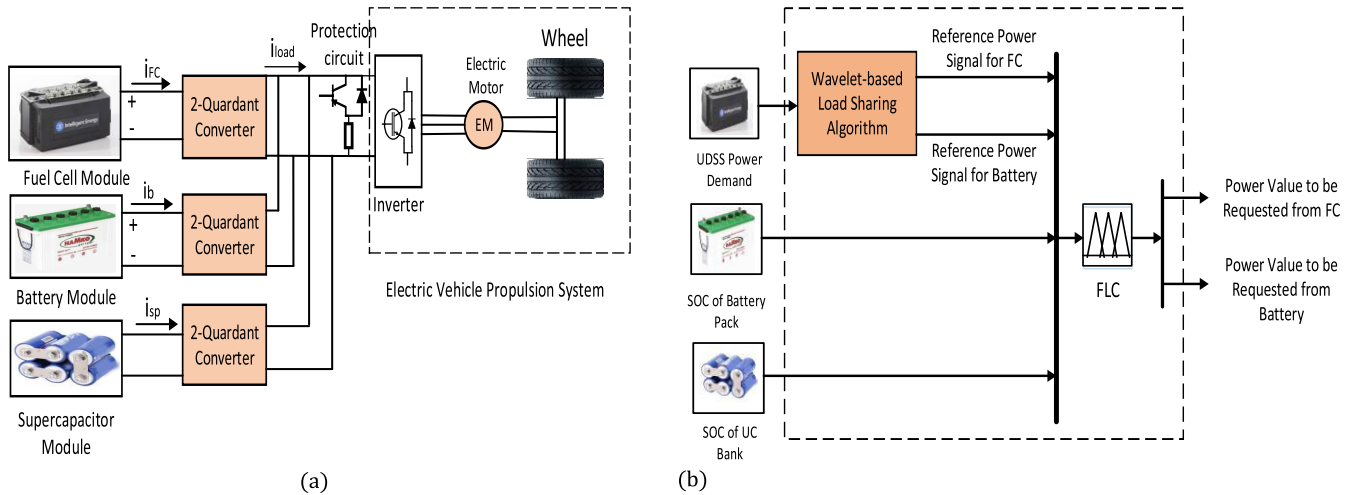

FIGURE 16. Representation of schematic diagram of FC-SC-battery hybrid vehicle for (a) Parallel energy-sharing control strategy [78] (b) Wavelet and FLC [80].

I_{UC-C} and I_{UC-D} present the UC charge and discharge signals through the UC voltage control loop. The schematic diagram of the strategy is represented in **Figure 16(a)**.

3) FLC STRATEGY

This strategy demonstrates a considerable dynamic response performance under load variations and controls the power flow from various sources [79]. The FLC algorithm offers an effective power management system classifying the vehicle load into three sections: steady-state, intermediate, and transient. The FC provides the steady-state power while the battery offers intermediate power, and the UC utilizes the power during acceleration and deceleration of the vehicle. This strategy uses two bi-directional DC/DC converters and a boost DC/DC converter. The system is simulated in MATLAB/Simulink, SimPowerSystem specifying mathematical and electrical modeling and visualizing the design in different situations like DC bus voltage, the SOC of UC and battery, load power variations, and so on. FLC algorithm employees FLC toolbox and ADVISOR result in the proposed strategy’s validity under different parameter variations. This strategy presents a practical design and implementation of the FLC system, maintaining DC bus voltage in a specific range and allowing power consumption economically.

4) WAVELET AND FLC

Wavelet and FLC based on the wavelet and fuzzy logic algorithm that focuses on developing the unit’s overall fuel economy and efficiency are presented in [80]. The proposed system considers FC as the primary source and battery and UC as the secondary sources. Three DC/DC converters are used with the DC bus. Wavelet and fuzzy logic algorithm visualizes mathematical models and opens a new era for improving vehicle performance. The whole system is implemented in MATLAB/Simulink and SimPowerSystem environment. The overall performance of the scheme

indicates better understanding compared to other strategies. The schematic diagram of the control strategy is illustrated in **Figure 16(b)**.

5) OPTIMAL/FLATNESS BASED CONTROL

An optimal/flatness-based control is presented in [81]. The strategy includes PMP, which uses the Euler-Lagrange equation. Like other methods, this system is also implemented in MATLAB/Simulink environment and results in optimal power consumption. Battery and UC fulfill the necessary power requirements. The constancy of DC bus voltage is successfully sustained.

6) GENETIC ALGORITHM AND PARETOFRONT ANALYSIS

A genetic algorithm and Pareto front analysis are given in [82]. A small-scale experimental platform is introduced to validate the suggested algorithm.

This algorithm applied in the FC/battery/SC HEV configuration intends to overcome the optimization problem’s difficulties. The SOC of the battery and SC state the time-based characteristics of these sources.

The outcomes of this process ensure optimal fuel economy and enlarge the lifetime of sources. For the proposed strategy, the following relations are demonstrated as

$$u_{fc}(t) = K_{p,b}(x_{b,ref} - x_b(t)) + K_{i,b} \int_0^t (x_{b,ref} - x_b(\tau))d\tau \tag{57}$$

$$u_b(t) = K_{p,sc}(x_{sc,ref} - x_{sc}(t)) \tag{58}$$

PI controller governs the state of battery around a constant reference $x_{b,ref}$ and proportional controller governs the state of SC around a constant reference $x_{sc,ref}$. u_{fc} and u_b present the output of the FC and battery, respectively. The strategy also introduces some relations between various

parameters:

$$x_{sc,ref}(t) = 0.6 - K_{ref,sc} \left(\frac{v(t)}{v_{max}} \right)^2 \quad (59)$$

$$P_b(t) = \begin{cases} +u_b(t) P_{ess}(t) & u_b(t) > 0 \text{ and } P_{ess}(t) > 0 \\ -u_b(t) P_{ess}(t) & u_b(t) < 0 \text{ and } P_{ess}(t) < 0 \\ 0 & \text{otherwise} \end{cases} \quad (60)$$

P_{ess} is the difference between P_{dem} and P_{fcdc}

7) AUTO-ADAPTIVE AND FILTERING BASED EMS

An auto-adaptive and filtering-based EMS is presented in [83]. This approach includes both the FLC and the sliding mode control. Secondary sources: battery, and SC, are used to be functioned appropriately to meet the high-density power demand. The effectiveness of this system is validated using MATLAB/SimPowerSystem environment. The evaluation is done in different driving cycles such as NEDC, NYCC, Supplemental federal test procedure (SFTP), Light vehicle test procedure (LVTP). The simulation ensures a safe and exciting power management unit. The load current can be calculated a

$$I_L = \frac{1.25}{V_{dc}} \left(0.5v^2 S_f C_x + MgC_r + M \frac{dv}{dt} \right) v \quad (61)$$

where v , S_f , C_x , M , C_r and g is the vehicle speed, the frontal vehicle surface, the aerodynamic drag coefficient, the vehicle mass, the rolling resistance coefficient, and gravitational acceleration constant, respectively.

Sliding mode control provides different modes:

- The Attraction Condition: The control signal

$$u = \begin{cases} 1, & \text{if } S(x, t) > 1 \\ 0, & \text{if } S(x, t) < 0 \end{cases}$$

- The Existence Condition: The existence condition

$$\begin{cases} \lim_{x \rightarrow 0^+} \dot{S} < 0 \\ \lim_{x \rightarrow 0^-} \dot{S} < 0 \end{cases} \quad \text{Otherwise, } \dot{S} < 0$$

\dot{S} is the sliding surface slop

- The Stability Condition: The stability condition

$$\begin{cases} \lim_{x \rightarrow 0^+} \dot{S} < 0 \\ \lim_{x \rightarrow 0^-} \dot{S} < 0 \end{cases} \quad \text{For All } t > t_s \text{ where } t_s \text{ presents the}$$

time required to reach the sliding surface.

8) INTELLIGENT EMS

An intelligent EMS is demonstrated in [84]. It is a multi-input and multi-output-based concept that enhances the constancy of the desired power level. The FC is attached with a unidirectional DC/DC converter. The battery and SC each are connected with a bidirectional DC/DC converter. SC contributes to the peak power demand, and the battery intends to lessen

the power contrast between the required power and FC supply power. The process is simulated in MATLAB/Simulink software.

9) POWER SHARING STRATEGY

A power-sharing strategy is presented in [85]. A combination of two FLC and one Haar WT is applied to the proposed system. This approach's main idea is to fulfill the required power demand to attain higher efficiency and eliminate power requirement fluctuations. This method introduces the LF-LRV tramway as the driving cycle. The discrete WT can be illustrated as

$$\begin{aligned} W(\lambda, u) &= \int s(t) \frac{1}{\sqrt{\lambda}} \psi \left(\frac{t-u}{\lambda} \right) dt, \\ \lambda &= 2^j, \\ u &= k2^j \end{aligned} \quad (62)$$

where W be the wavelet coefficient, $\psi(t)$ is the mother wavelet. λ is a scale parameter that governs the frequency band, and u is the position parameter that regulates the size of the time window.

10) OPTIMAL EMSs

An optimal EMS is represented in [86]. The basic idea behind this strategy is to ensure an optimal operation situation. Mainly it concerns the costing and efficiency of the whole system. A multi-population genetic algorithm and an artificial fish swarm algorithm have been applied, and the LF-LRV tramway driving cycle has been used. The concept proves the improved competence and low costing of this scheme. The proposed method has three energy storage system that presents different operating modes: the power demand $P_d = P_{fuel\ cell}$ when only the FC is provided. $P_d = P_{fuel\ cell} + P_{sc}$ when FC and SC are employed and $P_d = P_{fuel\ cell} + P_{sc} + P_{battery}$ when all sources are introduced. $P_d = P_{fuel\ cell} - |P_{sc}|$ presents the low power traction when FC and battery operated. Again $P_d = P_{fuel\ cell} - |P_{bat}|$ also represents the low power traction when FC and SC operate.

A comparative analysis of different control strategies for FC-Battery-UC configuration is presented in Table 13.

V. OUTCOME

Proper understanding of EV and HEV with associated configurations of battery- FC, UC- FC, battery-UC, and FC-battery-UC as ESSs are depicted in the proposed work. The discussed control strategies utilize several simulation platforms to test their efficacy. Figure 17 illustrates a graphical representation of the number of various simulation platforms utilized in the control techniques mentioned above schemes. Most of the control scheme utilizes MATLAB/Simulink. A few control schemes use ADVISOR and dSPACE platform to continue research work. Only two control strategy includes PSAT software. A summary illustration is also presented in Figure 18, shows the SC value utilized in different hybrid storage system for EV applications. It is

TABLE 13. Comparison among the above-mentioned control strategies for FC-Battery-UC configuration.

Ref.	Control Strategy	Simulation Platform	Exp. Validation	Advantages	Disadvantages
[77]	MPC	MATLAB/Simulink	Yes	<ul style="list-style-type: none"> • Computes accurate predictive values depending on system configuration and multiple variables 	<ul style="list-style-type: none"> • Much higher computational times • More complex • Requires a noticeable change to be applied to another electric vehicle
[78]	Parallel energy-sharing control strategy	MATLAB/Simulink	No	<ul style="list-style-type: none"> • UC aids FC and battery to avoid being overstressed • UC responds to the peak power demand • Provides the required power for vehicle start-up 	<ul style="list-style-type: none"> • Not accurate for all situations • Six control loops • FC requires power Complexity for interacting with all constituent elements • slope limiter to avoid transient response
[79]	FLC	MATLAB/Simulink	No	<ul style="list-style-type: none"> • Fast current response at the high power density • UC handles DC-bus voltage • Achieving peak shaving, decrease in fuel consumption, total braking energy is regenerated 	<ul style="list-style-type: none"> • FC supplies the power demand at normal operating condition • UC is required to fulfill the peak power demand
[80]	Wavelet-fuzzy logic-based EMS	MATLAB/Simulink	No	<ul style="list-style-type: none"> • Illustrates a suitable platform to respond to non-linear behaviors • Maintenance of the SOC level within suitable limits • Lessens fuel consumption and optimizes the size 	<ul style="list-style-type: none"> • Requires high power from FC to supply at the transient period
[81]	Optimal/flatness based-control	MATLAB/Simulink	No	<ul style="list-style-type: none"> • Minimizes FC power consumption • Efficient at different battery SOC levels • Increases lifetime of the hybrid sources 	<ul style="list-style-type: none"> • Insufficient FC power • Restrictions in battery charging range
[82]	Genetic algorithm and Pareto front analysis based EMS	MATLAB/Simulink	Yes	<ul style="list-style-type: none"> • Minimum battery steady-state error • Optimal power distribution among sources • Reduces stress on the battery 	<ul style="list-style-type: none"> • Dependency on FC • The battery capacity being faded to 80% of its initial value. • Prolonged acceleration time in case of the battery being unable to provide the required power
[83]	Auto-Adaptive filtering-based EMS	MATLAB/Simulink	No	<ul style="list-style-type: none"> • Reduces hydrogen consumption • Protects from an unsafe operating mode with better performance and speed • Handles an optimal energy distribution when the UC is fully charged 	<ul style="list-style-type: none"> • Fuzzy logic membership function and sliding mode control introducing complexity in the system • Inefficient battery lifetime ai simulation
[84]	Intelligent EMS	MATLAB/Simulink	No	<ul style="list-style-type: none"> • Rationalizing energy consumption • Ensures optimal energy sharing according to load demand • Reduction of the fuel consumption rate • Stable output, reliable operation 	<ul style="list-style-type: none"> • The necessity of PI controller

TABLE 13. (Continued.) Comparison among the above-mentioned control strategies for FC-Battery-UC configuration.

[85]	Power-sharing strategy based EMS	MATLAB/Simulink	No	<ul style="list-style-type: none"> Utilizes Harr-FLC to fulfill power demand Enhances EV system sustainability Cost-efficient Provides a smooth control capability 	<ul style="list-style-type: none"> Not optimal Undesirable SC output power Power increment-decrement occurs at high acceleration
[86]	Optimal energy management using a multi-objective approach	Not Mentioned	Yes	<ul style="list-style-type: none"> Aiming at minimized daily operating cost Satisfying the operating requirement 	<ul style="list-style-type: none"> Requires an improvement in the accuracy of the models for more precise reflection of the state of a real-world system Inaccurate lifetime prediction for sources

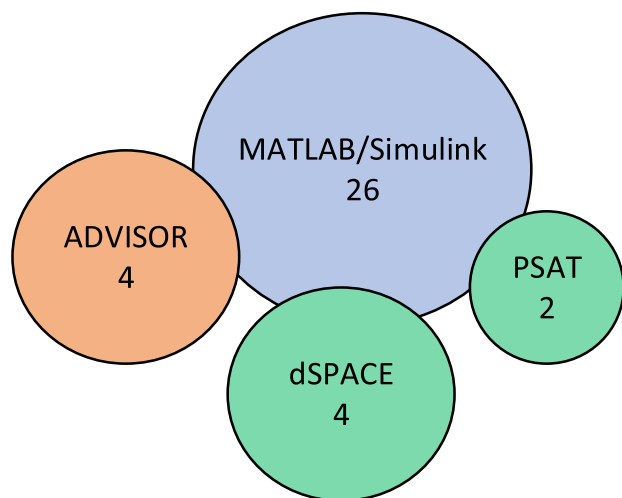

FIGURE 17. A numerical overview of simulation platforms for selected control schemes.

seen that the control strategies utilized in the Battery-UC configurations use a lower value of C, while the Battery-UC-FC configurations use a higher value of capacitors. Overall, the outcomes from the comprehensive review work are presented below.

- Rule and MPC based techniques for battery-UC HESS minimize energy losses and utilize UC for transient power responses. The techniques limit system flexibility, increase maintenance cost, generate current harmonics, and increase operating time. Real-time-based EMS for battery-UC HESS provides the DC-link stability and enhances the dynamic responses. The scheme presents complicated calculations and results in an error for imperfect weight sets. Fuzzy logic-based EMS limits the number of input variables and prolongs the run time. The analysis of MPC techniques suggest being a better platform than other nonlinear MPC techniques. Fuzzy logic EMS acts as more reliable, flexible, efficient than others, whereas MPC minimizes losses.
- Novel range-extended-based EMS for FC-battery HESS ensures optimal fuel consumption and enhances

battery lifetime. The strategy is uneconomic in battery SOC compensation. The proposed optimal EMSs provide optimal fuel consumption, maintain optimal sizing, and improve system efficiency. Inefficient battery SOC controlling and FC insensitiveness are the drawbacks of these techniques. Fuzzy logic-based EMS ensures a dynamic and robust operation while it limits the FC output power. Rule-based EMS presents optimal performance, optimal fuel consumption, and proper SOC controlling while it does not consider driving cycles. Rule-based EMS is preferred over others as it considers the optimal controlling of battery SOC and optimal fuel consumption.

- EMR and inversion-based control for FC-UC HESS is inefficient for controlling UC SOC due to power loss. The nonlinear control scheme can not provide global stability and increases costs. Linear and sliding control techniques provide a fast response for FC current and ensure robust performance, although it sometimes presents undesirable performances. The method is preferable to others as it maintains optimal power distribution and provides system stability.
- Fuzzy logic-based EMS for FC-battery-UC is the flexible platform that minimizes fuel consumption and maximizes system efficiency. It controls battery and UC SOC level in a specific range, but sometimes it faces undesirable SOC fluctuations and high run time. MPC-based EMS can predict system variables accurately through it creates a complex system and prolongs the execution time. Intelligent EMS ensures a stable system with minimum power consumption and optimal power distribution, whereas PI controller may increase costs. Fuzzy logic-based EMS is more efficient than others for its flexibility, minimum consumption, and SOC controlling.
- The main focus of research in this field should be on manufacturing batteries with more capacity and betterment in power densities. FCs should get free from fuel injection complexities. Design of SCs should be done with the availability of charging stations to keep in mind for the system’s more efficient performance.

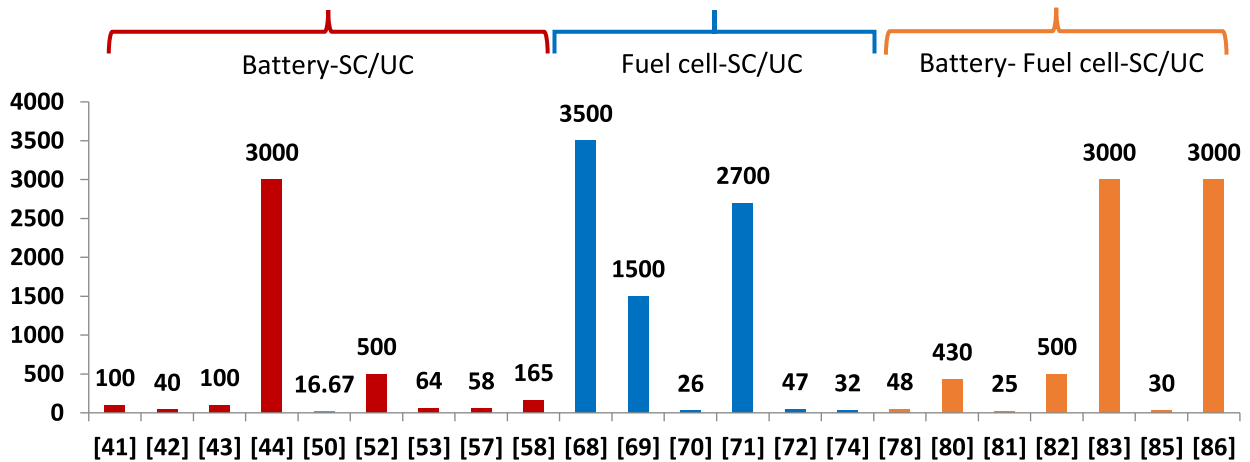

FIGURE 18. Various SC bank utilized in different control strategies of three different HES configurations.

VI. CONCLUSION

This paper shows an analytical study over different HEV control strategies thoroughly for four configurations: battery-UC, FC-UC, FC-battery, and FC-battery-UC. The study presents a relative analysis among different control strategies for different configurations based on objectives, control aspects, operating conditions, fuel consumptions, dynamic responses, battery lifetime, etc. The relative analysis suggests the fuzzy logic-based EMS as more efficient and flexible than others for battery-UC configuration. Rule-based EMS is preferable for battery-FC configuration as it handles battery SOC level at a specific range and minimizes fuel consumption. FC-UC HESS-based linear and sliding technique is efficient for optimal power-sharing and system stability. Fuzzy logic ESS for FC-battery-UC HESS minimizes fuel consumption, controls battery and UC SOC, and provides flexibility. The presented work suggests that the development of EV charging stations and the possibility of renting charges between two HEVs may be a promising topic for future research. Further research can be carried out on developing an efficient switching algorithm for different sources in EV. The enhancement of driving cycles in HEV operations can be emphasized to maintain optimal function.

ACKNOWLEDGMENT

The opinions, findings and conclusions or recommendations expressed in this material are those of the authors and do not necessarily reflect the views of the Science Foundation Ireland.

REFERENCES

- [1] A. Ghosh, "Possibilities and challenges for the inclusion of the electric vehicle (EV) to reduce the carbon footprint in the transport sector: A review," *Energies*, vol. 13, no. 10, pp. 2602–2623, 2020.
- [2] M. A. Hannan, M. M. Hoque, A. Mohamed, and A. Ayob, "Review of energy storage systems for electric vehicle applications: Issues and challenges," *Renew. Sustain. Energy Rev.*, vol. 69, pp. 771–789, Mar. 2017.
- [3] Y. Ligen, H. Vrabel, and H. H. Girault, "Mobility from renewable electricity: Infrastructure comparison for battery and hydrogen fuel cell vehicles," *World Electr. Vehicle J.*, vol. 9, no. 1, pp. 3–14, 2018.
- [4] Y. Wang, K. S. Chen, J. Mishler, S. C. Cho, and X. C. Adroher, "A review of polymer electrolyte membrane fuel cells: Technology, applications, and needs on fundamental research," *Appl. Energy*, vol. 88, no. 4, pp. 981–1007, Apr. 2011.
- [5] K. Sayed and H. A. Gabbar, "Electric vehicle to power grid integration using three-phase three-level AC/DC converter and PI-fuzzy controller," *Energies*, vol. 9, no. 7, pp. 532–547, 2016.
- [6] A. Sakalli and T. Kumbasar, "On the design and gain analysis of IT2-FLC with a case study on an electric vehicle," in *Proc. IEEE Int. Conf. Fuzzy Syst. (FUZZ-IEEE)*, Jul. 2017, pp. 1–6.
- [7] N. Vafamand, M. M. Arefi, M. H. Khooban, T. Dragicevic, and F. Blaabjerg, "Nonlinear model predictive speed control of electric vehicles represented by linear parameter varying models with bias terms," *IEEE J. Emerg. Sel. Topics Power Electron.*, vol. 7, no. 3, pp. 2081–2089, Sep. 2019.
- [8] N. Ding, K. Prasad, and T. T. Lie, "Design of a hybrid energy management system using designed rule-based control strategy and genetic algorithm for the series-parallel plug-in hybrid electric vehicle," *Int. J. Energy Res.*, vol. 45, no. 2, pp. 1627–1644, Feb. 2021.
- [9] X. Zhao, Q. Yu, M. Yu, and Z. Tang, "Research on an equal power allocation electronic differential system for electric vehicle with dual-wheeled-motor front drive based on a wavelet controller," *Adv. Mech. Eng.*, vol. 10, no. 2, pp. 1–24, 2018.
- [10] V. Monteiro, B. Exposto, J. C. Ferreira, and J. L. Afonso, "Improved vehicle-to-home (iV2H) operation mode: Experimental analysis of the electric vehicle as off-line UPS," *IEEE Trans. Smart Grid*, vol. 8, no. 6, pp. 2702–2711, Nov. 2017.
- [11] S. G. Wirasingha and A. Emadi, "Classification and review of control strategies for plug-in hybrid electric vehicles," *IEEE Trans. Veh. Technol.*, vol. 60, no. 1, pp. 111–122, Jan. 2011.
- [12] F. R. Salmasi, "Control strategies for hybrid electric vehicles: Evolution, classification, comparison, and future trends," *IEEE Trans. Veh. Technol.*, vol. 56, no. 5, pp. 2393–2404, Sep. 2007.
- [13] A. Ostadi and M. Kazerani, "A comparative analysis of optimal sizing of battery-only, ultracapacitor-only, and battery-ultracapacitor hybrid energy storage systems for a city bus," *IEEE Trans. Veh. Technol.*, vol. 64, no. 10, pp. 4449–4460, Oct. 2015.
- [14] M. Yilmaz and P. T. Krein, "Review of battery charger topologies, charging power levels, and infrastructure for plug-in electric and hybrid vehicles," *IEEE Trans. Power Electron.*, vol. 28, no. 5, pp. 2151–2169, May 2013.
- [15] J. Y. Yong, V. K. Ramachandaramurthy, K. M. Tan, and N. Mithulananthan, "A review on the state-of-the-art technologies of electric vehicle, its impacts and prospects," *Renew. Sustain. Energy Rev.*, vol. 49, pp. 365–385, Sep. 2015.
- [16] F. J. L. Daya, P. Sanjeevikumar, F. Blaabjerg, P. W. Wheeler, J. O. Ojo, and A. H. Ertas, "Analysis of wavelet controller for robustness in electronic differential of electric vehicles: An investigation and numerical developments," *Electr. Power Compon. Syst.*, vol. 44, no. 7, pp. 763–773, Apr. 2016.

- [17] Z. Yuan, L. Teng, S. Fengchun, and H. Peng, "Comparative study of dynamic programming and Pontryagin's minimum principle on energy management for a parallel hybrid electric vehicle," *Energies*, vol. 6, no. 4, pp. 2305–2318, Apr. 2013.
- [18] S. F. Tie and C. W. Tan, "A review of energy sources and energy management system in electric vehicles," *Renew. Sustain. Energy Rev.*, vol. 20, pp. 82–102, Apr. 2013.
- [19] S. Habib, M. M. Khan, F. Abbas, L. Sang, M. U. Shahid, and H. Tang, "A comprehensive study of implemented international standards, technical challenges, impacts and prospects for electric vehicles," *IEEE Access*, vol. 6, pp. 13866–13890, 2018.
- [20] H. Shareef, M. M. Islam, and A. Mohamed, "A review of the state-of-the-art charging technologies, placement methodologies, and impacts of electric vehicles," *Renew. Sustain. Energy Rev.*, vol. 64, pp. 403–420, Oct. 2016.
- [21] A. Khaligh and Z. Li, "Battery, ultracapacitor, fuel cell, and hybrid energy storage systems for electric, hybrid electric, fuel cell, and plug-in hybrid electric vehicles: State of the art," *IEEE Trans. Veh. Technol.*, vol. 59, no. 6, pp. 2806–2814, Jul. 2010.
- [22] A. Panday and H. O. Bansal, "A review of optimal energy management strategies for hybrid electric vehicle," *Int. J. Veh. Technol.*, vol. 2014, pp. 1–19, Nov. 2014.
- [23] Y. Wang, L. Wang, M. Li, and Z. Chen, "A review of key issues for control and management in battery and ultra-capacitor hybrid energy storage systems," *eTransportation*, vol. 4, May 2020, Art. no. 100064.
- [24] Y. Wang, Z. Sun, X. Li, X. Yang, and Z. Chen, "A comparative study of power allocation strategies used in fuel cell and ultracapacitor hybrid systems," *Energy*, vol. 189, Dec. 2019, Art. no. 116142.
- [25] Y. Wang, X. Li, L. Wang, and Z. Sun, "Multiple-grained velocity prediction and energy management strategy for hybrid propulsion systems," *J. Energy Storage*, vol. 26, Dec. 2019, Art. no. 100950.
- [26] Y. Wang, Z. Sun, and Z. Chen, "Energy management strategy for battery/supercapacitor/fuel cell hybrid source vehicles based on finite state machine," *Appl. Energy*, vol. 254, Nov. 2019, Art. no. 113707.
- [27] Y. Wang, Z. Sun, and Z. Chen, "Development of energy management system based on a rule-based power distribution strategy for hybrid power sources," *Energy*, vol. 175, pp. 1055–1066, May 2019.
- [28] S. Ahmadi, S. M. T. Bathaee, and A. H. Hosseinpour, "Improving fuel economy and performance of a fuel-cell hybrid electric vehicle (fuel-cell, battery, and ultra-capacitor) using optimized energy management strategy," *Energy Convers. Manage.*, vol. 160, pp. 74–84, Mar. 2018.
- [29] P. García, J. P. Torreglosa, L. M. Fernández, and F. Jurado, "Control strategies for high-power electric vehicles powered by hydrogen fuel cell, battery and supercapacitor," *Expert Syst. Appl.*, vol. 40, no. 12, pp. 4791–4804, Sep. 2013.
- [30] M. A. Hannan, F. A. Azidin, and A. Mohamed, "Hybrid electric vehicles and their challenges: A review," *Renew. Sustain. Energy Rev.*, vol. 29, pp. 135–150, Jan. 2014.
- [31] H. S. Das, C. W. Tan, and A. H. M. Yatim, "Fuel cell hybrid electric vehicles: A review on power conditioning units and topologies," *Renew. Sustain. Energy Rev.*, vol. 76, pp. 268–291, Sep. 2017.
- [32] X. Lü, Y. Wu, J. Lian, Y. Zhang, C. Chen, P. Wang, and L. Meng, "Energy management of hybrid electric vehicles: A review of energy optimization of fuel cell hybrid power system based on genetic algorithm," *Energy Convers. Manage.*, vol. 205, Feb. 2020, Art. no. 112474.
- [33] N. Ding, K. Prasad, and T. Lie, "The electric vehicle: A review," *Int. J. Electr. Hybrid Vehicles*, vol. 9, no. 1, pp. 49–66, 2017.
- [34] N. Sulaiman, M. A. Hannan, A. Mohamed, E. H. Majlan, and W. R. W. Daud, "A review on energy management system for fuel cell hybrid electric vehicle: Issues and challenges," *Renew. Sustain. Energy Rev.*, vol. 52, pp. 802–814, Dec. 2015.
- [35] N. Sulaiman, M. A. Hannan, A. Mohamed, P. J. Ker, E. H. Majlan, and W. R. W. Daud, "Optimization of energy management system for fuel-cell hybrid electric vehicles: Issues and recommendations," *Appl. Energy*, vol. 228, pp. 2061–2079, Oct. 2018.
- [36] H. Li, A. Ravey, A. N'Diaye, and A. Djerdir, "A review of energy management strategy for fuel cell hybrid electric vehicle," in *Proc. IEEE Vehicle Power Propuls. Conf. (VPPC)*, Dec. 2017, pp. 1–6.
- [37] R. Wang and S. M. Lukic, "Review of driving conditions prediction and driving style recognition based control algorithms for hybrid electric vehicles," in *Proc. IEEE Vehicle Power Propuls. Conf.*, Sep. 2011, pp. 1–7.
- [38] A. K. Podder, K. Ahmed, N. K. Roy, and M. Habibullah, "Design and simulation of a photovoltaic and fuel cell based micro-grid system," in *Proc. Int. Conf. Energy Power Eng. (ICEPE)*, Dhaka, Bangladesh, Mar. 2019, pp. 1–6.
- [39] M. Habib and F. Khoucha, "Rule-based energy management strategy for fuel cell/battery electric vehicle," in *Proc. 1st Int. Conf. Power Electron. Appl.*, Djelfa, Algeria, 2013, pp. 1–10.
- [40] *Simscape Power Systems User's Guide (Simscape Components)*, The MathWorks, 3 Apple Hill Drive, Natick, MA, USA. Accessed: Jan. 11, 2020. [Online]. Available: <https://wenku.baidu.com/view/95146447915f804d2a16c140.html>
- [41] P. Bhattacharyya, A. Banerjee, S. Sen, S. K. Giri, and S. Sadhukhan, "A modified semi-active topology for battery-ultracapacitor hybrid energy storage system for EV applications," in *Proc. IEEE Int. Conf. Power Electron., Smart Grid Renew. Energy (PESGRE)*, Jan. 2020, pp. 1–6.
- [42] S. Yu, D. Lin, Z. Sun, and D. He, "Efficient model predictive control for real-time energy optimization of battery-supercapacitors in electric vehicles," *Int. J. Energy Res.*, vol. 44, no. 9, pp. 7495–7506, Jul. 2020.
- [43] B. Hredzak, V. G. Agelidis, and M. Jang, "A model predictive control system for a hybrid battery-ultracapacitor power source," *IEEE Trans. Power Electron.*, vol. 29, no. 3, pp. 1469–1479, Mar. 2014.
- [44] W. Yaici, L. Kouchachvili, E. Entchev, and M. Longo, "Dynamic simulation of battery/supercapacitor hybrid energy storage system for the electric vehicles," in *Proc. 8th Int. Conf. Renew. Energy Res. Appl. (ICRERA)*, Nov. 2019, pp. 460–465.
- [45] B.-H. Nguyen, R. German, J. P. F. Trovao, and A. Bouscayrol, "Real-time energy management of battery/supercapacitor electric vehicles based on an adaptation of Pontryagin's minimum principle," *IEEE Trans. Veh. Technol.*, vol. 68, no. 1, pp. 203–212, Jan. 2019.
- [46] S. D. Vidhya and M. Balaji, "Modelling, design and control of a light electric vehicle with hybrid energy storage system for Indian driving cycle," *Meas. Control*, vol. 52, nos. 9–10, pp. 1420–1433, Nov. 2019.
- [47] X. Lu, Y. Chen, M. Fu, and H. Wang, "Multi-objective optimization-based real-time control strategy for battery/ultracapacitor hybrid energy management systems," *IEEE Access*, vol. 7, pp. 11640–11650, 2019.
- [48] Q. Zhang, W. Deng, S. Zhang, and J. Wu, "A rule based energy management system of experimental battery/supercapacitor hybrid energy storage system for electric vehicles," *J. Control Sci. Eng.*, vol. 2016, pp. 1–17, Jan. 2016.
- [49] K. Gokce and A. Ozdemir, "A rule based power split strategy for battery/ultracapacitor energy storage systems in hybrid electric vehicles," *Int. J. Electrochem. Sci.*, vol. 11, no. 2, pp. 1228–1246, 2016.
- [50] J. Cao and A. Emadi, "A new battery/UltraCapacitor hybrid energy storage system for electric, hybrid, and plug-in hybrid electric vehicles," *IEEE Trans. Power Electron.*, vol. 27, no. 1, pp. 122–132, Jan. 2012.
- [51] I. Azizi and H. Radjeai, "A new strategy for battery and supercapacitor energy management for an urban electric vehicle," *Electr. Eng.*, vol. 100, no. 2, pp. 667–676, Jun. 2018.
- [52] A. Geetha and C. Subramani, "A significant energy management control strategy for a hybrid source EV," *Int. J. Electr. Comput. Eng.*, vol. 9, no. 6, pp. 4580–4585, Dec. 2019.
- [53] H. Xiaoliang, T. Hiramatsu, and H. Yoichi, "Energy management strategy based on frequency-varying filter for the battery supercapacitor hybrid system of electric vehicles," in *Proc. World Electr. Vehicle Symp. Exhib. (EVS)*, Nov. 2013, pp. 1–6.
- [54] J. M. A. Curti, X. Huang, R. Minaki, and Y. Hori, "A simplified power management strategy for a supercapacitor/battery hybrid energy storage system using the half-controlled converter," in *Proc. 38th Annu. Conf. IEEE Ind. Electron. Soc. (IECON)*, Oct. 2012, pp. 4006–4011.
- [55] Q. Zhang and G. Li, "Experimental study on a semi-active battery-supercapacitor hybrid energy storage system for electric vehicle application," *IEEE Trans. Power Electron.*, vol. 35, no. 1, pp. 1014–1021, Jan. 2020.
- [56] X. Wang, J. Tao, and R. Zhang, "Fuzzy energy management control for battery/ultra-capacitor hybrid electric vehicles," in *Proc. Chin. Control Decis. Conf. (CCDC)*, May 2016, pp. 6207–6211.
- [57] U. Manandhar, N. R. Tummuru, S. K. Kollimalla, A. Ukil, G. H. Beng, and K. Chaudhari, "Validation of faster joint control strategy for battery- and supercapacitor-based energy storage system," *IEEE Trans. Ind. Electron.*, vol. 65, no. 4, pp. 3286–3295, Apr. 2018.
- [58] K. Han, J. Tao, L. Xie, and R. Zhang, "Rule and MPC based hybrid energy allocation system for hybrid electric vehicle," in *Proc. Chin. Automat. Congr. (CAC)*, 2019, pp. 57–62.

- [59] C. Gokul, S. Khanna, C. Gnanavel, K. Vanchinathan, and L. Patrica, "Experimental investigation of hybrid battery/ supercapacitor energy storage system for electric vehicles," *Int. J. Adv. Sci. Technol.*, vol. 29, no. 4, pp. 1013–1021, 2020.
- [60] S. Hu, Z. Liang, D. Fan, and X. He, "Hybrid ultracapacitor–battery energy storage system based on quasi-Z-source topology and enhanced frequency dividing coordinated control for EV," *IEEE Trans. Power Electron.*, vol. 31, no. 11, pp. 7598–7610, Nov. 2016.
- [61] A. L. Allegre, R. Trigui, and A. Bouscayrol, "Different energy management strategies of hybrid energy storage system (HESS) using batteries and supercapacitors for vehicular applications," in *Proc. IEEE Vehicle Power Propuls. Conf.*, Sep. 2010, pp. 1–6.
- [62] J.-J. Hwang, J.-S. Hu, and C.-H. Lin, "A novel range-extended strategy for fuel cell/battery electric vehicles," *Sci. World J.*, vol. 2015, pp. 1–8, Jan. 2015.
- [63] X. Hu, N. Murgovski, L. M. Johannesson, and B. Egardt, "Optimal dimensioning and power management of a fuel cell/battery hybrid bus via convex programming," *IEEE/ASME Trans. Mechatronics*, vol. 20, no. 1, pp. 457–468, Feb. 2015.
- [64] M.-J. Kim and H. Peng, "Power management and design optimization of fuel cell/battery hybrid vehicles," *J. Power Sources*, vol. 165, no. 2, pp. 819–832, Mar. 2007.
- [65] L. Xu, J. Li, J. Hua, X. Li, and M. Ouyang, "Optimal vehicle control strategy of a fuel cell/battery hybrid city bus," *Int. J. Hydrogen Energy*, vol. 34, no. 17, pp. 7323–7333, Sep. 2009.
- [66] G. Zhang, W. Chen, and Q. Li, "Modeling, optimization and control of a FC/battery hybrid locomotive based on ADVISOR," *Int. J. Hydrogen Energy*, vol. 42, no. 29, pp. 18568–18583, Jul. 2017.
- [67] W. Xiao, L. Wang, D. Liu, and W. Zhang, "An optimized energy management strategy for fuel cell hybrid vehicles," *IOP Conf. Ser., Mater. Sci. Eng.*, vol. 612, no. 4, 2019, Art. no. 042088.
- [68] P. Thounthong, S. Raël, and B. Davat, "Control strategy of fuel cell/supercapacitors hybrid power sources for electric vehicle," *J. Power Sources*, vol. 158, no. 1, pp. 806–814, Jul. 2006.
- [69] H. El Fadil, F. Giri, J. M. Guerrero, and A. Tahrir, "Modeling and nonlinear control of a fuel cell/supercapacitor hybrid energy storage system for electric vehicles," *IEEE Trans. Veh. Technol.*, vol. 63, no. 7, pp. 3011–3018, Sep. 2014.
- [70] T. Azib, O. Bethoux, G. Remy, and C. Marchand, "Saturation management of a controlled fuel-cell/ultracapacitor hybrid vehicle," *IEEE Trans. Veh. Technol.*, vol. 60, no. 9, pp. 4127–4138, Nov. 2011.
- [71] A. Wahib, G. Samir, A. Hatem, and M. Abdelkader, "Energy management strategy of a fuel cell electric vehicle: Design and implementation," *Int. J. Renew. Energy Res.*, vol. 9, no. 3, pp. 1154–1164, 2019.
- [72] S. Bourdim, T. Azib, K. E. Hemsas, and C. Larouci, "Efficient energy management strategy for fuel cell ultracapacitor hybrid system," in *Proc. Int. Conf. Electr. Syst. Aircr., Railway, Ship Propuls. Road Vehicles Int. Transp. Electrific. Conf. (ESARS-ITEC)*, Nov. 2016, pp. 1–6.
- [73] O. Kraa, H. Ghodbane, R. Saadi, M. Y. Ayad, M. Becherif, A. Aboubou, and M. Bahri, "Energy management of fuel cell/supercapacitor hybrid source based on linear and sliding mode control," *Energy Procedia*, vol. 74, pp. 1258–1264, Aug. 2015.
- [74] F. J. Perez-Pinal, C. Nunez, R. Alvarez, and I. Cervantes, "Power management strategies for a fuel cell/supercapacitor electric vehicle," in *Proc. IEEE Vehicle Power Propuls. Conf.*, Sep. 2007, pp. 605–609.
- [75] W. Andari, S. Ghozzi, H. Allagui, and A. Mami, "Design, modeling and energy management of a PEM fuel cell/supercapacitor hybrid vehicle," *Int. J. Adv. Comput. Sci. Appl.*, vol. 8, no. 1, pp. 273–278, 2017.
- [76] B. Allaoua and B. Mebarki, "Hybrid energy source management composed of a fuel cell and super-capacitor for an electric vehicle," *Adv. Automobile Eng.*, vol. 5, no. 2, pp. 1–4, 2016.
- [77] Amin, R. T. Bambang, A. S. Rohman, C. J. Dronkers, R. Ortega, and A. Sasongko, "Energy management of fuel cell/battery/supercapacitor hybrid power sources using model predictive control," *IEEE Trans. Ind. Informat.*, vol. 10, no. 4, pp. 1992–2002, Nov. 2014.
- [78] J. H. Wong, T. Sutikno, N. Idris, N. Rumzi, and M. Anwari, "A parallel energy-sharing control strategy for fuel cell hybrid vehicle," *Telkomnika*, vol. 9, no. 2, pp. 357–364, 2011.
- [79] M. C. Kisacikoglu, M. Uzunoglu, and M. S. Alam, "Fuzzy logic control of a fuel cell/battery/ultra-capacitor hybrid vehicular power system," in *Proc. IEEE Vehicle Power Propuls. Conf.*, Sep. 2007, pp. 591–596.
- [80] O. Erdinc, B. Vural, and M. Uzunoglu, "A wavelet-fuzzy logic based energy management strategy for a fuel cell/battery/ultra-capacitor hybrid vehicular power system," *J. Power Sources*, vol. 194, no. 1, pp. 369–380, Oct. 2009.
- [81] M. Benaouadj, A. Aboubou, M. Ayad, M. Bahri, and A. Boucetta, "Fuel cells, batteries and super-capacitors stand-alone power systems management using optimal/flatness based-control," *AIP Conf.*, vol. 1758, no. 1, 2016, Art. no. 030022.
- [82] F. Odeim, J. Roes, and A. Heinzel, "Power management optimization of an experimental fuel cell/battery/supercapacitor hybrid system," *Energies*, vol. 8, no. 7, pp. 6302–6327, Jun. 2015.
- [83] J. Snoussi, S. Ben Elghali, M. Benbouzid, and M. F. Mimouni, "Auto-adaptive filtering-based energy management strategy for fuel cell hybrid electric vehicles," *Energies*, vol. 11, no. 8, pp. 2118–2137, 2018.
- [84] R. S. Chandan, T. S. Kiran, G. Swapna, and T. V. Muni, "Intelligent control strategy for energy management system with fuel cell/battery/SC," *J. Crit. Rev.*, vol. 7, no. 2, pp. 344–348, 2020.
- [85] Q. Li, W. Chen, Z. Liu, M. Li, and L. Ma, "Development of energy management system based on a power sharing strategy for a fuel cell-battery-supercapacitor hybrid tramway," *J. Power Sources*, vol. 279, pp. 267–280, Apr. 2015.
- [86] H. Zhang, J. Yang, J. Zhang, P. Song, and M. Li, "Optimal energy management of a fuel cell-battery-supercapacitor-powered hybrid tramway using a multi-objective approach," *Proc. Inst. Mech. Eng., F, J. Rail Rapid Transit*, vol. 234, no. 5, pp. 511–523, 2020.



AMIT KUMER PODDER received the B.S. and M.S degrees from the Khulna University of Engineering & Technology, Khulna, Bangladesh, in 2016 and 2019, respectively. He joined as a Lecturer with the Department of Electrical and Electronic Engineering, Khulna University of Engineering and Technology, in 2017, where he is currently serving as an Assistant Professor. As an author, he has published 11 peer-reviewed journal articles and 15 conference papers in several IEEE co-sponsored international conferences. His research interests include renewable energy integration, intelligent control systems, virtual power plant, and smart micro-grid systems. He achieved the Prime Minister Gold Medal and the University Gold Medal for outstanding performance at the undergraduate level. He also serves as a reviewer for two prestigious journals, namely, *Renewable and Sustainable Energy Reviews* (Elsevier) and *IET Renewable Power Generation*.



OISHIKHA CHAKRABORTY (Student Member, IEEE) was born in Chittagong, Bangladesh. She is currently pursuing the B.Sc. degree in electrical and electronic engineering with the Khulna University of Engineering & Technology, Khulna, Bangladesh. Her research work is focused on designing charging station for electric vehicle applications along with solar energy employment and energy storage systems.



SAYEMUL ISLAM is currently pursuing the B.Sc. degree in electrical and electronic engineering (EEE) with the Khulna University of Engineering and Technology, Khulna, Bangladesh. He is currently engaged in several research works, such as virtual power plant (VPP), hybrid electric vehicle, and MPPT techniques. His research interests include power systems, renewable energy, electric vehicle, and the IoT.



NALLAPANENI MANOJ KUMAR received the B.Tech. degree in electrical and electronics engineering from GITAM University, Visakhapatnam, India, the M.Tech. degree in renewable energy technologies from Karunya University, Coimbatore, India, and the M.A. degree in environmental economics from Annamalai University (Directorate of Distance Education), Chidambaram, India. He was a Research Fellow (Jr.) at the University of Malaysia Pahang worked on

the project “Solar Photovoltaics as Urban Infrastructure.” He is currently with the School of Energy and Environment, City University of Hong Kong, Hong Kong. He has published 13 chapters in scientific books, more than 100 research articles in scientific journals, and more than 30 articles in international conferences. His research mainly focuses on renewable energy, building integrated photovoltaic systems, energy management, modeling and performance investigation of energy systems, building energy optimization, smart cities, new dimensions in solar energy, applications of Internet of Things, and blockchain technology.



HASSAN HAES ALHELOU (Senior Member, IEEE) is currently a Faculty Member of Tishreen University, Lattakia, Syria. He is also with University College Dublin, Ireland. He has published more than 100 research papers in high-quality peer-reviewed journals and international conferences. He has participated in more than 15 industrial projects. His major research interests include power systems, power system dynamics, power system operation and control, dynamic state estimation, frequency control, smart grids, microgrids, demand response, load shedding, and power system protection. He was included in the 2018 and 2019 Publons list of the top 1% best reviewer and researchers in the field of engineering. He was a recipient of the Outstanding Reviewer Award from *Energy Conversion and Management* journal, in 2016; *ISA Transactions* journal, in 2018; *Applied Energy* journal, in 2019; and many other awards. He was also a recipient of the Best Young Researcher in the Arab Student Forum Creative among 61 researchers from 16 countries at Alexandria University, Egypt, in 2011. He has also performed more than 600 reviews for high prestigious journals, including IEEE TRANSACTIONS ON INDUSTRIAL INFORMATICS, IEEE TRANSACTIONS ON INDUSTRIAL ELECTRONICS, *Energy Conversion and Management*, *Applied Energy*, the *International Journal of Electrical Power & Energy Systems*.

... ..