

Received January 30, 2021, accepted February 25, 2021, date of publication March 9, 2021, date of current version April 5, 2021.

Digital Object Identifier 10.1109/ACCESS.2021.3064937

Influence of Aging on Creepage Discharge Characteristics of Oil-Paper Insulation Under AC-DC Combined Voltage

JIN FUBAO¹, (Member, IEEE), ZHOU YUANXIANG², (Member, IEEE), AND LIANG BIN¹

¹School of Water Resources and Electric Power, Qinghai University, Xining 810016, China

²State Key Laboratory of Control and Simulation of Power Systems and Generation Equipment, Department of Electrical Engineering, Tsinghua University, Beijing 100084, China

Corresponding author: Jin Fubao (jinfubao@163.com)

This work was supported in part by the National Natural Science Foundation of China under Grant 51865049, in part by the Open Project of State Key Laboratory of Plateau Ecology and Agriculture, Qinghai University, under Grant 2019-ZZ-13, in part by the Ministry of Education Chunhui Plan under Grant QDCH2018004, in part by the Basic Research Program of Qinghai Province under Grant 2020-ZJ-708, and in part by the National Basic Research Program of China (973 Program) under Grant 2011CB209400.

ABSTRACT There is a relative lack of research on the development of creepage discharge in aged oil-paper insulation subjected to AC-DC combined voltage in converter transformers. In this study, based on the physical and chemical properties of oil-paper, we propose a sphere-plate electrode model to study the creepage discharge parameters and characteristic spectra of aged oil-paper subjected to AC-DC combined voltage. The results show that the creepage discharge inception voltage of aged oil-paper is related to the AC voltage component of the AC-DC combined voltage. However, when the DC voltage component is 60 kV, the flashover phenomenon was found to occur in one of the severely aged samples before the AC voltage was applied. Despite being subjected to the same DC voltage, the flashover phenomenon did not occur in three other samples aged to different degrees. Large-amplitude discharges were found to appear earlier in the severely aged samples. At the same creepage discharge stage, as the aging time of the oil-paper increased, the number of large-amplitude discharges was found to rapidly increase, and the time interval between adjacent discharges was found to gradually decrease. At each stage of the creepage discharge, the small-amplitude discharge has a “hump” shaped distribution. The larger the DC voltage component, the shorter the endurance time of aged oil-paper, and the more severe the damage to the oil-paper. The DC voltage component was found to have an accelerating effect on the development of creepage discharge in aged oil-paper insulation.

INDEX TERMS Aging, oil-paper insulation, AC-DC combined voltage, DC voltage component, creepage discharge, inception voltage.

I. INTRODUCTION

The internal insulation material of the converter transformer, which is one of the major components of the ultra-high voltage direct current (UHVDC) transmission system, is the same as that of the traditional AC transformer. However, unlike traditional AC transformers, converter transformers have valve-side winding that can withstand multiple voltage types such as AC voltage, harmonic voltage components, and AC-DC combined voltage (ADCV) [1], [2]. The insulation performance of oil-paper (OP) insulation, which is the

primary insulating material of converter transformers, gradually deteriorates under the long-term effects of stress from temperature and electric field. The transformer insulating paper aging research team of the international council on large electric systems (CIGRE) indicated in a 2007 report that the average operating life of power transformers in most countries is approximately 30 years [3]. As the operation time of the UHVDC transmission project in China increases, the performance of the OP insulation will gradually deteriorate, and the performance of the insulation system will reduce due to aging. This will gradually increase the probability of accidents in the converter transformer. The failure of converter transformers, which occupy a central role in the

The associate editor coordinating the review of this manuscript and approving it for publication was Pavlos I. Lazaridis¹.

UHVDC transmission system, will cause severe losses to the national economy and power grid.

In the past few decades, many scholars have studied the discharge characteristics of aged oil-impregnated paper insulation under AC, DC, and impulse voltages. These works majorly include two aspects: 1) the influence of aging on the electrical characteristics of OP insulation, such as breakdown voltage, partial discharge, dielectric response, gas production characteristics, and dielectric loss, etc. [4]–[10] and 2) the study of the physical and chemical characteristics of aging OP insulation, such as furfural in oil, acid value, micro-water, degree of polymerization (DP), and aging assessment [11]–[15]. Although some studies have been conducted on the discharge characteristics of OP insulation under ADCV, there have been few reports on the discharge characteristics of aged OP insulation under such voltages [16]–[21]. However, the insulating structure and operating conditions of converter transformers differ from those of traditional AC transformers. According to CIGRE statistics, the failure rate of the insulating structures of converter transformers is much higher than that of the insulating structures of AC transformers (about twice), and many of these insulating problems are caused by creepage discharge at the OP interface [22]. As the use of converter transformers is relatively recent when compared to AC transformers, few research reports have studied the creepage discharge characteristics of aged OP insulation under ADCV [23]. Therefore, it is necessary to conduct research on the creepage discharge development characteristics of typical aged OP insulation under ADCV.

In this study, OP insulation samples with different aging degrees were prepared, where accelerated thermal aging was performed at 130 °C. Then, combined with the physical and chemical characteristics analysis method, the creepage discharge parameters of the aged OP under ADCV were studied. Finally, the discharge signal characteristics of the aged OP insulation during the development of creepage discharge were statistically analyzed, and the effects of aging and ADCV on the creepage discharge characteristics of the OP insulation were investigated.

II. EXPERIMENTAL SETUP AND METHODS

A. ELECTRODE MODEL

The experiment used a typical sphere-plate electrode model recommended by CIGRE Method II. Both the high-voltage and ground electrodes are made of stainless steel. Oil-impregnated insulating paper was placed between the high-voltage electrode and ground electrode. The electrode model parameters are marked as shown in Fig. 1 [23], [24].

B. SAMPLES

Karamay 25 transformer oil was used in the experiment. After the transformer oil was degassed, dried, and purified, the gas volume fraction was found to be less than 2%, and the micro-water content was less than 5 $\mu\text{l/l}$, which met the requirements of GB/T 7595 [23]–[26].

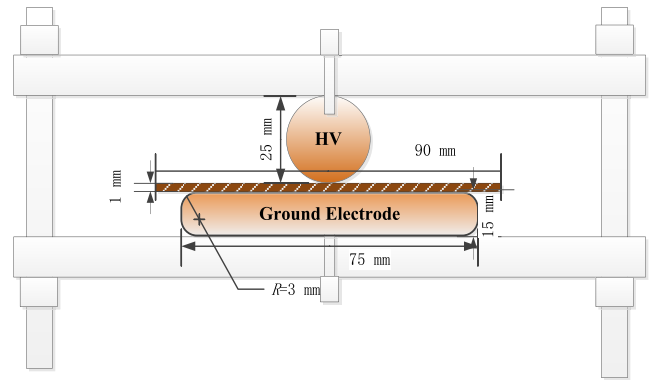

FIGURE 1. Sphere-plate electrodes configuration.

The insulating paper was dried for 72 h at 100° and then immersed in oil for 72 h in an environment with a vacuum of about 10 Pa and a temperature of 60°. The transformer oil used in the experiment was unaged oil. Then, the container impregnated with the OP sample was filled with nitrogen, sealed, and placed in a high-temperature drying box at 130° for accelerated thermal aging. Before aging, the moisture content in the insulating paper was 2.239%. After aging, the moisture content in the oil was 9 $\mu\text{l/l}$, and the moisture content in the insulating paper was 1.685%.

To study the thermal aging process of OP, the aging time was selected according to the accelerated thermal aging rules. The aging time of 0, 30, 60, and 100 days correspond to the aging states Aging0, Aging1, Aging2, and Aging3, respectively.

In the early stages of aging (Aging0–Aging1), the DP of the sample decreased slowly from 1250 to 1001. In the middle stage of aging (Aging1–Aging2), the DP decreased rapidly. At the end of the aging period (Aging2–Aging3), the DP decreased gradually, and the DP of the Aging3 sample reached 248, which was close to the end-of-life of the insulating paper.

C. EXPERIMENTAL PLATFORM

Fig. 2 shows the configuration of the experimental system. U_{DC} is a 100 kV DC voltage source, which is connected to the circuit through the current limiting resistor R_2 [23]–[26]. U_{AC} is a 100 kV AC voltage source, which is connected to the circuit through a resistor R_1 and blocking capacitor C_1 [23]–[26]. The partial discharge detection system uses the pulse current method to detect partial discharge signals. It can collect the discharge pulse signals in real time to form the discharge characteristic spectra. The circuit was tested and found to be discharge free up to 75 kV [23]–[26].

D. VOLTAGE APPLICATION METHOD

The experiment uses the parallel superposition method to obtain ADCV, as shown in Fig. 3. Firstly, the DC voltage component is accelerated to the preset amplitude at a rate of 1 kV/s and maintained at this level for half an hour. Then, the AC voltage component is increased to 20% of the breakdown

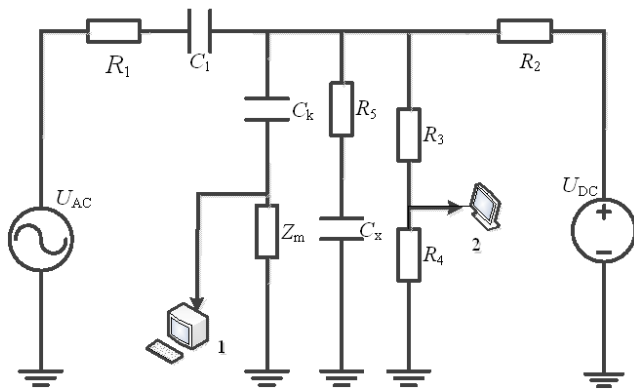

FIGURE 2. Schematic of experimental platform. $R_1 = 10M\Omega$, $R_2 = 1M\Omega$, R_3/R_4 is a resistive voltage divider (10000 : 1), $R_5 = 5M\Omega$, and $C_1 = 0.2\mu F$. The component labeled 1 is the partial discharge detection system, and the component labeled 2 is a digitizing oscilloscope.

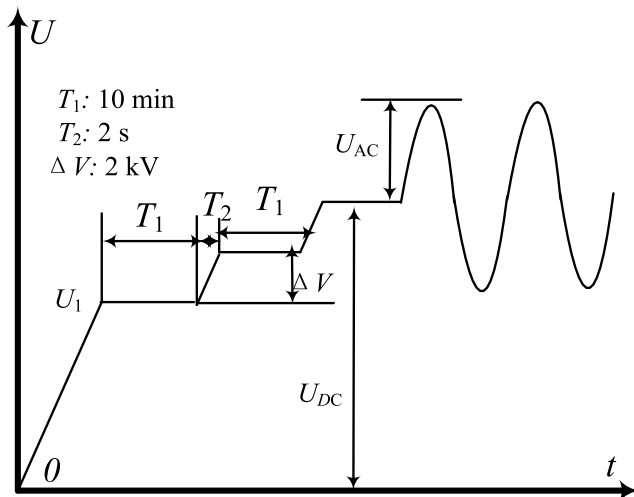

FIGURE 3. Voltage application method.

voltage of transformer oil at the rate of 1 kV/s, and the voltage is maintained for 10 min. Later, the AC voltage component is accelerated by 2 kV at a rate of 1 kV/s. A stable repetitive discharge signal is generated, and the corresponding voltage is the creepage discharge inception voltage (CDIV). In this manner, the AC voltage components are continuously amplified until a discharge signal greater than 100 pC appears, at which point the amplification is stopped. The applied voltage is then kept constant, and the timer is started. The discharge signal during the whole creepage discharge process is collected until the flashover occurs and the timer is stopped. The time measured during this process is called the endurance time (ET).

III. RESULTS AND DISCUSSION

A. CREEPAGE DISCHARGE INCEPTION VOLTAGE OF AGED OP

The ADCV was applied to the OP with four degrees of aging, and the CDIV under the different DC voltage components was measured. Ten repeated tests were performed on samples

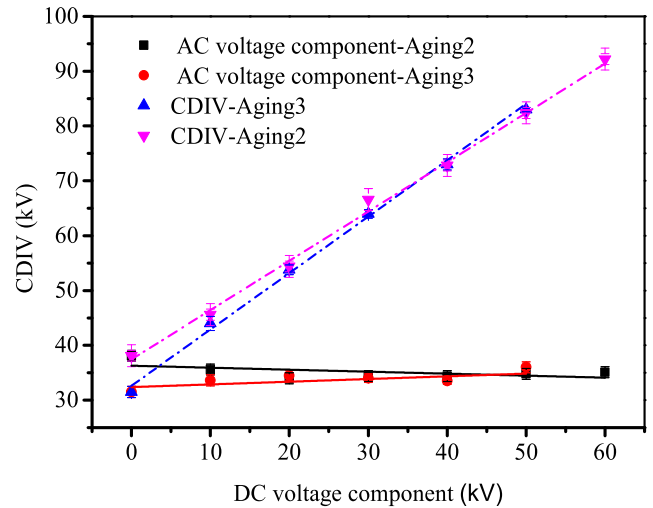

FIGURE 4. CDIV of differently aged samples.

of the same aging stage. The influence of aging and the DC voltage component on the CDIV of the OP insulation are analyzed. The CDIV of four aging stage showed similar laws. Therefore, the Aging2 and the Aging3 were selected to compare and analyze the characteristics of CDIV. The CDIV of aged OP was measured under ADCV with the DC voltage component varied from 0 to 60 kV, as shown in Fig. 4. The DC voltage component of 0 kV corresponds to a pure AC voltage.

Fig. 4 shows the relationship between the CDIV and the AC voltage component in the Aging2 samples. The CDIV under pure AC voltage is the smallest and is equal to approximately 36 kV. It can be seen from the figure that the CDIV increases gradually with increasing DC voltage component. When the DC voltage component is 60 kV, the inception voltage is 93 kV. As the CDIV increases, the AC voltage component in the ADCV gradually decreases, but the reduction is small. It can be seen from Fig. 4 that the variation trend of the CDIV of the Aging3 sample is the same as that of the Aging2 sample. The CDIV of the Aging3 sample under pure AC voltage is approximately 32 kV, which is lower than that of Aging2. The AC voltage component required for the onset of creepage discharge in the Aging3 sample is lower than that required for the Aging2 sample.

As shown in Fig. 4, it can be found that with the increase in the DC voltage component, the CDIV of the aged OP gradually increases. Notably, in the Aging2 sample, a flashover phenomenon occurs when the DC voltage component is 70 kV, and then the AC voltage component is increased to 20 kV. At this stage, the flashover voltage of the aged OP under pure DC voltage is about twice that under pure AC voltage. However, in the Aging3 sample, when the DC voltage component is 60 kV, a flashover phenomenon occurs during the DC voltage component holding period. However, under the same voltage, this phenomenon does not occur in the other three aged OP insulation samples (Aging0, Aging1, Aging2).

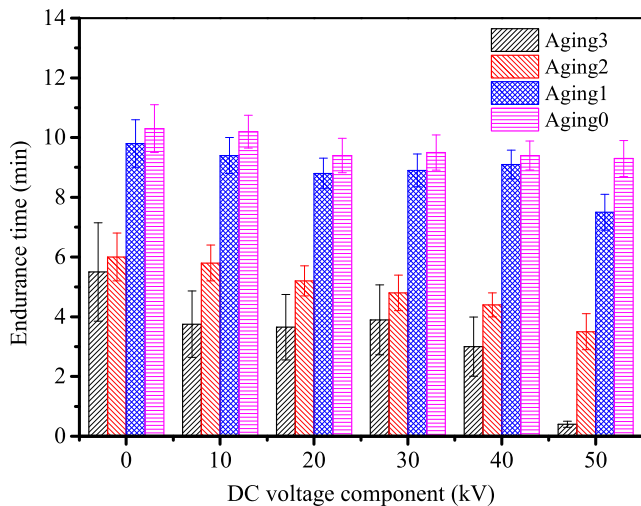

FIGURE 5. Endurance time for samples with different aging time.

It can be seen that, under ADCV, the CDIV of aged OP is related to the AC voltage component and the degree of aging of the OP. However, the DC voltage component exacerbates the damage of the insulating paper. With the deterioration of the OP insulation aging, when the DC voltage component is greater than a certain amplitude, a flashover phenomenon will occur in the DC voltage preloading process.

B. ENDURANCE TIME OF AGED OP INSULATION

As the time of aging increases, the DP of the OP insulation gradually decreases, which has a significant effect on its mechanical strength. This in turn affects the development of the creepage discharge process in the OP. The ET of the OP at different aging stages was measured under ADCV, and the result is shown in Fig. 5.

Fig. 5 depicts that with the increase in the DC voltage component, the ET of the OP in the same aging stage gradually decreases. The more severe the aging of the OP, the greater the decrease in the ET. Under the same voltage, the ET gradually reduces with increase in the aging stage. The ET of the Aging0 and Aging1 OP samples does not change significantly under the effect of different DC voltage components. The ET of the Aging2 and Aging3 samples were lower than that of the Aging1 sample, and the ET of the Aging3 sample was the lowest. The ET is drastically shortened, specifically when the DC voltage component is 50 kV. The ET does not change considerably in the less aged samples. The larger the DC voltage component, the shorter the ET.

The DP of the aged OP decreased, thereby reducing its mechanical strength. Therefore, when a large energy discharge occurs, the fibers of the aged OP are more easily broken, and the fibers of the insulating paper can be ablated and destroyed in a shorter time to easily form a discharge channel between the fibers. This change makes it easier for the creepage discharge to develop in the aged OP insulation under the influence of the force from the electric field. Correspondingly, the time required from the start of the discharge to the final flashover breakdown will be reduced,

and a longer carbonization channel will be left on the surface of the insulating paper simultaneously, as shown in Figs. 6(c) and (f).

C. PHENOMENON OF CREEPAGE DISCHARGE AND ANALYSIS ON DIFFERENTLY AGED OP INSULATION

During the research process, in order to avoid the influence of randomness, ten repeated tests are performed on samples of the same aging stage. After these tests, the carbonization traces on the surface of the insulating paper at the same aging stage show similar laws under the same ADCV. With the increase in aging, the experimental phenomenon exhibited by the aged OP under different applied voltages is different. Fig. 6 shows the phenomenon after flashover of the Aging2 and Aging3 samples. The damage characteristics of the aged OP under the ADCV are explored.

It can be seen from Fig. 6 that after the breakdown occurs under different voltages, different shapes of carbonization marks are formed on the surface of the insulating paper. The length of the carbonization marks formed on the surface of the insulating paper by creepage discharge is denoted by d in Fig 6(f).

It can be seen from Figs. 6(a)–(c) that as the DC voltage component increases, the carbonization traces on the surface of the Aging2 insulating paper samples gradually become elongated and the damage caused to the surface of the insulating paper by the creepage discharge intensifies. Under pure AC voltage, the damage to the surface of the insulating paper is relatively light, and there is only one breakdown point near the HV electrode. As the DC voltage component increases, a few carbonization marks appear around the surface of the paper that is in contact with the electrodes. d gradually increases, and dendritic white spots appear around the carbonization traces. Figs. 6(d)–(f) show the surface condition of the Aging3 insulating paper samples under the AC and the ADCV. The change in the surface damage of the Aging3 sample insulating paper with voltage is the same as that of the Aging2 sample, and the damage to the surface of the insulating paper under AC voltage is still the least. However, under the same ADCV, the damage to the insulating paper surface of the Aging3 sample is more severe than that to the Aging2 sample. Moreover, the larger the DC voltage component, the more severe the damage to the surface of the insulating paper.

Overall, under pure AC voltage, the breakdown point of the OP insulation occurs at the junction of the electrodes, transformer oil, and insulating paper. Under ADCV, the breakdown point appears on the upper surface of the insulating paper at a distance from the high-voltage electrode, and it continues to develop forward as the DC voltage component increases. The longer the aging time, the more severe the damage.

As the insulating paper is a porous material, the fibers overlap each other. The micro-pores and the pore size distribution inside the insulating paper will have a significant impact on the creepage discharge development in the OP.

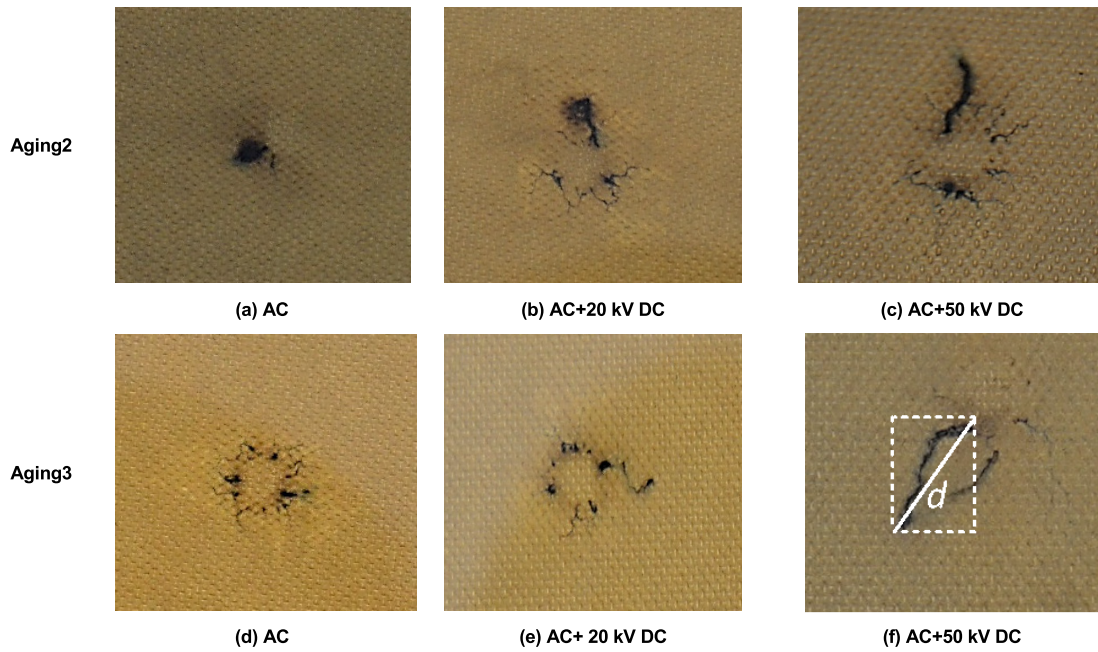

FIGURE 6. Characteristic parameters of creepage discharge in new OP under different ADCVs.

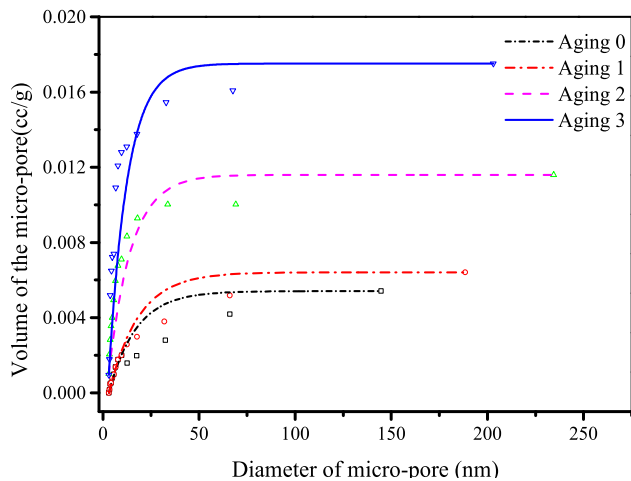

FIGURE 7. OP insulation pore size distribution with different degrees of aging.

Fig. 7 demonstrates that as the degree of aging of the OP increases, the diameter of the micro-pore shows an increasing trend. The pore diameter of the insulating paper increases from 140 nm to 237 nm after aging. The pores in the insulating paper gradually develop from micro-pores to fine pores. Simultaneously, the pore volume at 140 nm increased by approximately 4 times from 0.004 to 0.017 cc/g, and the pore volume of other pores also gradually increased. As the insulating paper ages, the porosity of the insulating paper continues to increase. The compactness of the insulating paper gradually decreases, resulting in a more loose structure. These factors increase the permeability of the insulating paper to the oil, which in turn affects the mechanical and electrical properties of the insulating paper.

Aging causes evident changes in the surface morphology and microstructure of the insulating paper. Consequently, the diameter of micro-pores increases, which causes the oil gap discharge to crack and form bubbles due to the creepage discharge. Part of the gas bubbles will escape to the surface of the insulating paper, and part of the gas bubbles will stay inside the insulating paper. Under the ADCV, the AC electric field is primarily concentrated on oil and gas bubbles. The gas bubbles are discharged inside the insulating paper and cause damage and ablation to the internal structure of the insulating paper. These effects cause the surface fibers of the insulating paper to be lifted. The DC electric field is primarily concentrated in the insulating paper, and a large amount of space charge is injected into the insulating paper under the DC electric field [26], [27]. Under the combined effect of the AC-DC electric fields, the trapped charges are de-trapped by external disturbances and release a large amount of energy. In addition, aging causes the mechanical strength of the insulating paper to decrease. Therefore, the creepage discharge easily develops on the surface of the aged OP and leaves a long carbonization mark on the surface of the insulating paper.

D. DEVELOPMENT RATE OF CREEPAGE DISCHARGE OF OP INSULATION WITH DIFFERENT DEGREES OF AGING

The ET of the aged OP reduces with increase in the DC voltage component in the ADCV. The developed velocity of creepage discharge under different proportions of ADCV under different degrees of aging is shown in Fig. 8.

The developed velocity of the creepage discharge is defined as the ratio between the length of d and ET. Fig. 8 illustrates that as the aging time increases and the DC

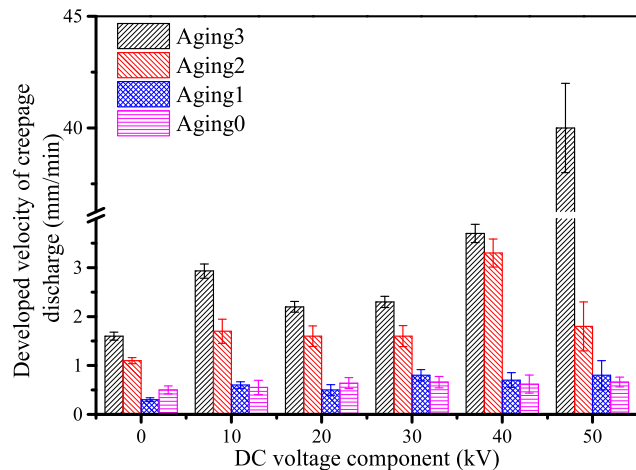

FIGURE 8. Developed velocity of creepage discharge at different aging time.

voltage component increases, the developed velocity of the creepage discharge gradually increases. When the DC voltage component is 50 kV, the flashover occurs in a short period of more than 20 s after the discharge signal appears, specifically in the Aging3 samples. As the aging stage increases, the developed velocity under the same DC voltage component gradually increases. This is because the fiber of the insulating paper undergoes fiber hydrolysis and oxidative degradation under heat. In severe cases, it can cause the decomposition of cellulose, and even carbonization or graphitization reactions to occur. Under 130 °C thermal aging, the water physically absorbed by the fiber is desorbed, and some glucose groups in the cellulose structure begin to dehydrate, causing the intact cellulose to gradually degrade into multiple bundles of cellulose. The mechanical strength of insulating paper is reduced due to the thermal degradation of cellulose. This process can be defined as the “embrittlement” process of cellulose. Thus, under the action of the electric field, high-energy electrons continuously bombard the fiber chain of the insulating paper, and the fiber chain is easily broken. Therefore, under the ADCV, the developed velocity gradually accelerated with the degree of aging. Accordingly, the length of d also gradually increases. The aging not only leads to a decline in the mechanical strength of the insulating paper, but also reduces creep resistance. The DC voltage component has an accelerating effect on the development of creepage discharge in the aged OP.

E. CHARACTERISTIC SPECTRA OF THE CREEPAGE DISCHARGE DEVELOPMENT PROCESS OF AGED OP INSULATION UNDER ADCV

Partial discharge is an effective method for detecting the insulating state of OP. Here, the pulse current method is implemented to collect the discharge signals of the aged OP under ADCV. Then, these discharge signals are statistically combined into a discharge characteristic spectra. As the OP under ADCV is simultaneously subjected to the combined effects of AC and DC voltage, the method of expressing discharge

characteristics is different from previously reported methods where the sample was subjected to AC voltage alone. Therefore, this study uses $\Delta t_{pre}-Q$, $n-Q$, and $Q-t$ as the statistical parameters of the spectrum to explore the creepage discharge development of aged OP under ADCV, where Q , Δt_{pre} , and n corresponds to the discharge amplitude, interval time between two adjacent discharges, and number of discharges in the corresponding statistical time, respectively [23].

The characteristics of creepage discharge development were studied in Aging1 and Aging3 samples. By comparing the characteristics of the creepage discharge spectra of the two aged samples, the development process of creepage discharge in aged OP under ADCV is divided into four stages.

1) CHARACTERISTIC SPECTRA OF CREEPAGE DISCHARGE DEVELOPMENT PROCESS OF AGING1 SAMPLE

OP insulation will accumulate polarized charges at the OP interface under DC voltage. The results shown the space charge achieved a balanced condition after 30 min of applied DC voltage [27]. The polarization charge will affect the creepage discharge development process and discharge characteristic parameters of aged OP insulation. The creepage discharge development process of the Aging1 sample under ADCV was studied. The discharge signals during the creepage discharge are collected to obtain the characteristic spectra, as shown in Fig. 9. Among them, the DC and AC voltage components are 20 kV and 34 kV, respectively. The initial stage of creepage discharge under ADCV is shown in Fig. 9(a). The $Q-t$ and the $n-Q$ spectra show that the discharge is relatively stable at this stage. The corresponding discharge amplitude is majorly concentrated at approximately 80 pC, and the number of discharges is approximately 4000. The discharge amplitude of approximately 2500 pC appears sporadically during the discharge process. The interval time between two adjacent 2500 pC discharges is large. From the $\Delta t_{pre}-Q$ spectra, it can be seen that Δt_{pre} is primarily distributed in the range from 0–0.04 s, and there are more scattered discharges in this interval. There are also scattered discharges in the range of 0.04–0.06 s, and the discharge signal does not appear concentrated. The second stage of the creepage discharge process is shown in Fig. 9(b). The discharge amplitude at this stage is primarily concentrated at 140 pC, and a large number of discharges at this stage are mainly concentrated in the range of 0–0.02 s. In this stage, the number of 2500 pC discharges increased to more than 2,000. The $Q-t$ spectra indicates that it takes 100 s for the discharge amplitude to increase to 2500 pC from 100 pC.

The third stage of the creepage discharge process is shown in Fig. 9(c), in which the number of 2500 pC discharges increased to 3000. Δt_{pre} is majorly distributed in the range from 0–0.01 s, and there are some scattered discharges in the interval between 0.02 s and 0.05 s. At this stage, the insulation performance of the OP gradually deteriorates, and the creepage discharge enters a period of rapid development. Carbonization traces appear on the surface of the insulating paper, and its insulating performance is further reduced.

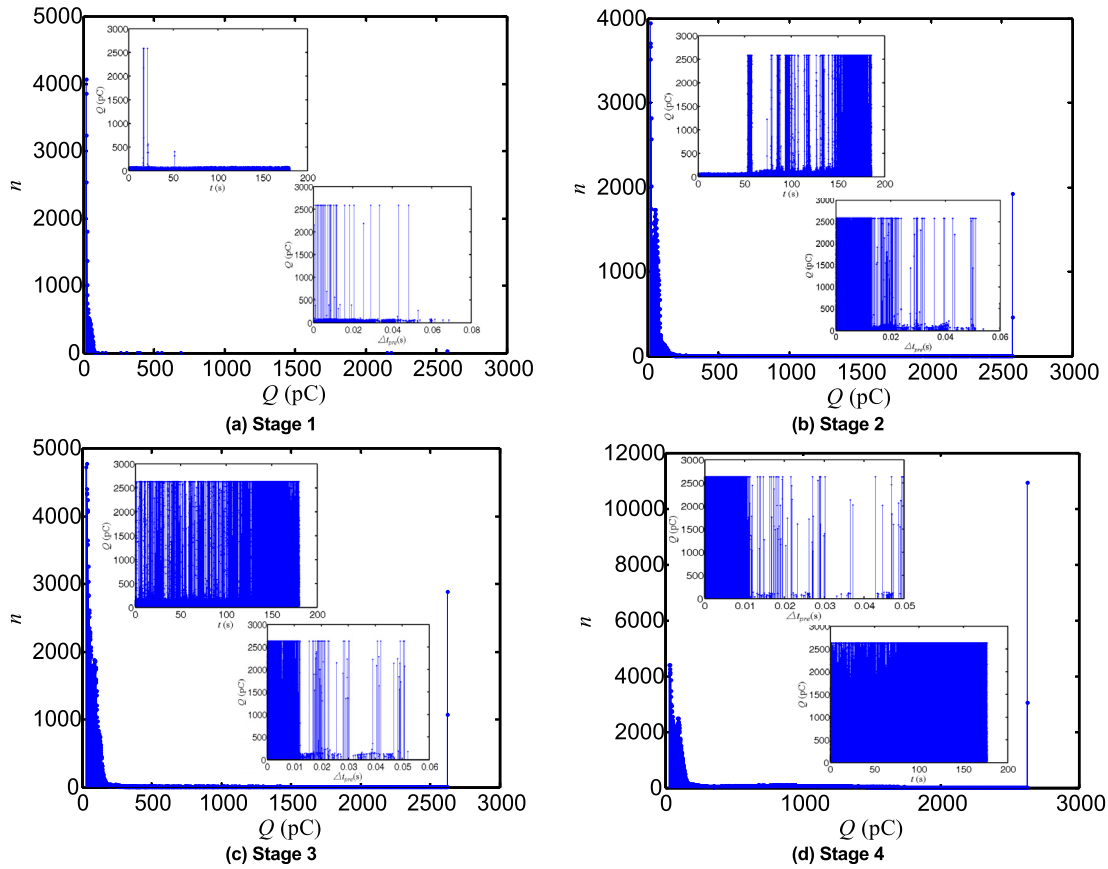

FIGURE 9. Different stages of the characteristic spectra ($\Delta t_{pre} - Q$ An-Q AQ-t) of creepage discharge in the Aging1 sample under 34 kV AC and 20 kV DC.

The fourth stage of the creepage discharge process is shown in Fig. 9(d). The $Q - t$ spectra shows that the frequency of occurrence of large-amplitude discharge (LAD, 2500 pC) significantly increases in this stage, which exacerbates the damage to the insulating paper. Due to the further reduction of OP insulating performance, a large number of high amplitude discharges occur, and the discharge repetition rate is higher. Consequently, Δt_{pre} at this stage is more concentrated than the previous three stages and mainly distributed in the interval between 0 s and 0.01 s, which exacerbates the deterioration of the insulating performance of OP and promotes the development of insulating defects. The above process is a feedback process that affects and interacts with itself. This process repeats its development cycle until the last flashover breakdown occurs.

2) CHARACTERISTIC SPECTRA OF CREEPAGE DISCHARGE DEVELOPMENT PROCESS OF AGING3 SAMPLE

Fig. 10 shows the characteristic spectra of creepage discharge of Aging3 sample. The voltage applied at this stage is the same as that in the Aging1. The initial stage of creepage discharge is shown in Fig. 10(a), which shows that the amplitude of the discharge signal of the Aging3 sample rises much faster than that in the first stage of the Aging1 sample, and LAD occurs at the beginning of the creepage discharge.

This phenomenon did not occur in the initial stage of Aging1. Δt_{pre} is scattered in the interval between 0.01–0.05 s, and the 2500 pC discharge is scattered in each interval. The second stage of the creepage discharge process is shown in Fig.10(b). LAD has a gradual upward trend. The number of LADs increased to nearly 8000, and the number of small-amplitude discharge (SAD, 110–220 pC) is far less than that of LAD. The number of LADs increases rapidly in a short period of time, and the damage to the surface of the insulating paper is intensified. The LADs are mainly distributed in the range from 0–0.01s and also in the interval between 0.02–0.05 s. As shown in Fig. 10(c), the number of LADs rapidly increases to 13,500, showing a rapid increasing trend. Δt_{pre} gradually moves closer to the interval between 0–0.01 s, and a scattered distribution is observed in the interval between 0.02–0.06 s, which showed a significant decreasing trend. In Fig. 10(d), Δt_{pre} is primarily distributed in the interval between 0–0.01 s, and the number of discharges in the interval between 0.02–0.04 s is significantly less than the previous three stages. The number of LADs is considerably larger than the number of SADs. It can be seen that the number of discharges increased sharply and Δt_{pre} shortens at this stage, intensifying the degree of damage to the insulating paper surface and accelerating the development of creepage discharge.

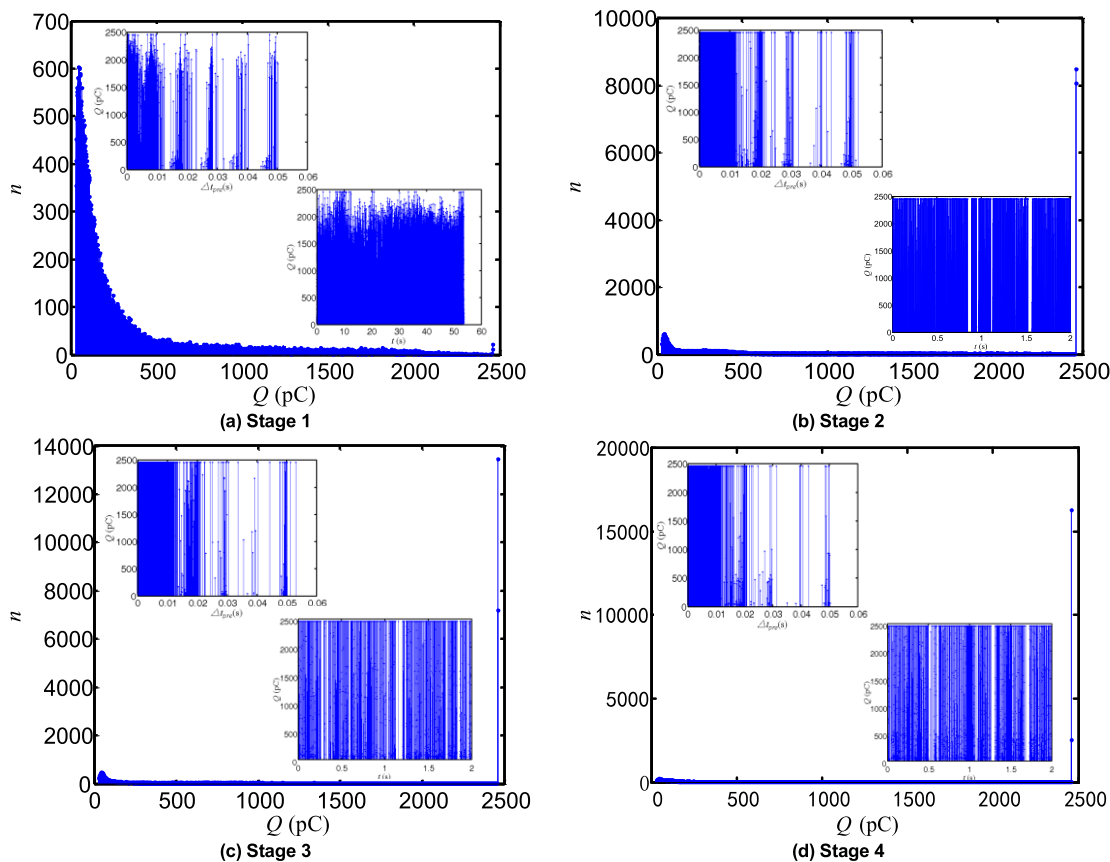

FIGURE 10. Different stages of the characteristic spectra ($\Delta t_{pre} - Q - An - Q - AQ - t$) of creepage discharge in the Aging3 sample under 34 kV AC and 20 kV DC.

On comparing the two development processes, it can be seen that the discharge amplitude of the initial stage of the Aging3 sample is greater than that of the Aging1 sample. In addition, the discharge interval time is shortened, and the number of LADs increases. In the second and third stages of the Aging3 sample, the number of LADs is greater than the number of SADs. Near the flashover stage, the discharge in the Aging3 is majorly composed of LADs, and the number of LADs is significantly larger than that of the SADs. At each stage of the creepage discharge, the SAD has a “hump” shaped distribution.

IV. CONCLUSION

When subjected to ADCV, the CDIV of aged OP is related to the AC voltage component of the ADCV. As the CDIV increases, the AC voltage component in the ADCV gradually decreases, but the reduction is small. However, the DC voltage component exacerbates the damage to the insulating paper. When the DC voltage component is greater than a certain amplitude, a flashover phenomenon occurs in the severely aged OP insulation during the DC voltage preloading process, before the AC voltage component is applied. Despite being subjected to the same DC voltage, the flashover phenomenon does not occur in three other samples aged to different degrees.

Aging leads to a decline in the mechanical strength of the insulating paper and reduces the creep resistance. The greater the DC voltage component, the shorter the endurance time of the aged OP and the more severe the damage to the OP during the creepage discharge process. The DC voltage component has the effect of accelerating the development of creepage discharges on aged OP insulation.

At the same creepage discharge stage, for an OP with greater degree of aging, the LAD appears earlier, the number of LAD rapidly increases, and the interval time between adjacent discharges gradually decreases. The distribution range of SAD at each stage of creepage discharge development is “hump-shaped”.

REFERENCES

- [1] L. Zehong, “The achievement of ± 800 kV ultra-high voltage DC transmission engineering from Xiang Jiaba to Shang Hai,” *China Three Gorges*, vol. 11, pp. 65–70, Nov. 2012.
- [2] P. Sarma Maruvada, “800-kV HVDC transmission systems,” in *Proc. IEEE/PES Transmiss. Distrib. Conf. Expo.*, Apr. 2008, pp. 1–2.
- [3] *CIGRE Task Force D1.01.10: Ageing of Cellulose in Mineral-Oil Insulated Transformers*, Brochure no. 323, 2007.
- [4] C. Tang, C. L. R. Huang, and Y. L. Z. Mengzhao, “The breakdown voltage of power transformer insulation paper after thermal aging,” *Trans. China Electro Tech. Soc.*, vol. 25, no. 11, pp. 1–8, Nov. 2010.
- [5] P. Sun, W. Sima, M. Yang, and J. Wu, “Influence of thermal aging on the breakdown characteristics of transformer oil impregnated paper,” *IEEE Trans. Dielectr. Electr. Insul.*, vol. 23, no. 6, pp. 3373–3381, Dec. 2016.

- [6] A. A. Abdelmalik, S. J. Dodd, L. A. Dissado, N. M. Chalashkanov, and J. C. Fothergill, "Charge transport in thermally aged paper impregnated with natural ester oil," *IEEE Trans. Dielectr. Electr. Insul.*, vol. 21, no. 5, pp. 2318–2328, Oct. 2014.
- [7] R. Sarathi, K. S. Yadav, and M. Swarna, "Understanding the surface discharge characteristics of thermally aged copper sulphide diffused oil impregnated pressboard material," *IEEE Trans. Dielectrics Electr. Insul.*, vol. 22, no. 5, pp. 2513–2521, Oct. 2015.
- [8] J. Dai, Z. Wang, and P. Jarman, "Creepage discharge on insulation barriers in aged power transformers," *IEEE Trans. Dielectr. Electr. Insul.*, vol. 17, no. 4, pp. 1327–1335, Aug. 2010.
- [9] S.-Q. Wang, G.-J. Zhang, J.-L. Wei, S.-S. Yang, M. Dong, and X.-B. Huang, "Investigation on dielectric response characteristics of thermally aged insulating pressboard in vacuum and oil-impregnated ambient," *IEEE Trans. Dielectr. Electr. Insul.*, vol. 17, no. 6, pp. 1853–1862, Dec. 2010.
- [10] H. Li, L. Zhong, Q. Yu, S. Mori, and S. Yamada, "The resistivity of oil and oil-impregnated pressboard varies with temperature and electric field strength," *IEEE Trans. Dielectr. Electr. Insul.*, vol. 21, no. 4, pp. 1851–1856, Aug. 2014.
- [11] R. Liao, S. Liang, L. Yang, J. Hao, and J. Li, "Comparison of ageing results for transformer oil-paper insulation subjected to thermal ageing in mineral oil and ageing in retardant oil," *IEEE Trans. Dielectr. Electr. Insul.*, vol. 19, no. 1, pp. 225–232, Feb. 2012.
- [12] R. Liao, Y. Lin, P. Guo, H. Liu, and H. Xia, "Thermal aging effects on the moisture equilibrium curves of mineral and mixed oil-paper insulation systems," *IEEE Trans. Dielectr. Electr. Insul.*, vol. 22, no. 2, pp. 842–850, Apr. 2015.
- [13] Y. Lin, C. Wei, F. Tao, and J. Li, "Aging assessment of oil-paper insulation of power equipment with furfural analysis based on furfural generation and partitioning," *IEEE Trans. Power Del.*, vol. 34, no. 4, pp. 1626–1633, Aug. 2019.
- [14] T. K. Saha and P. Purkait, "Investigation of polarization and depolarization current measurements for the assessment of oil-paper insulation of aged transformers," *IEEE Trans. Dielectr. Electr. Insul.*, vol. 11, no. 1, pp. 144–154, Feb. 2004.
- [15] D. Wang, Z. Zhu, L. Zhang, Y. Qian, W. Su, T. Chen, S. Fan, and Y. Zhao, "Influence of metal transformer materials on oil-paper insulation after thermal aging," *IEEE Trans. Dielectr. Electr. Insul.*, vol. 26, no. 2, pp. 554–560, Apr. 2019.
- [16] B. Qi, Z. Wei, and C. Li, "Creepage discharge of oil-pressboard insulation in AC-DC composite field: Phenomenon and characteristics," *IEEE Trans. Dielectr. Electr. Insul.*, vol. 23, no. 1, pp. 237–245, Feb. 2016.
- [17] E. Takahashi, Y. Tsutsumi, K. Okuyama, and F. Ogata, "Partial discharge characteristics of oil-immersed insulation systems under DC, combined AC-DC and DC reversed polarity voltage," *IEEE Trans. Power App. Syst.*, vol. PAS-5, no. 1, pp. 411–420, Jan. 1976.
- [18] Y. Wang, X. Wei, Q. Chen, Y. Huang, and H. Nie, "Breakdown characteristics of converter transformer insulation under composite AC and DC voltage," in *Proc. IEEE 9th Int. Conf. Properties Appl. Dielectric Mater.*, Harbin, China, Jul. 2009, pp. 634–637.
- [19] J. Li, X. Han, Z. Liu, X. Yao, and Y. Li, "PD characteristics of oil-pressboard insulation under AC and DC mixed voltage," *IEEE Trans. Dielectr. Electr. Insul.*, vol. 23, no. 1, pp. 444–450, Feb. 2016.
- [20] A. Cavallini, G. Montanari, M. Tozzi, and X. Chen, "Diagnostic of HVDC systems using partial discharges," *IEEE Trans. Dielectr. Electr. Insul.*, vol. 18, no. 1, pp. 275–284, Feb. 2011.
- [21] J. Li, L. Zhang, X. Han, X. Yao, and Y. Li, "PD detection and analysis of oil-pressboard insulation under pulsed DC voltage," *IEEE Trans. Dielectr. Electr. Insul.*, vol. 24, no. 1, pp. 324–330, Feb. 2017.
- [22] F. Tao, J. Li, C. Wei, Y. Li, and J. Zhang, "Thermal ageing effect on the failure time of oil-paper insulation at combined AC-DC voltage," in *Proc. IEEE Electr. Insul. Conf. (EIC)*, Montreal, QC, Canada, Jun. 2016, pp. 284–287.
- [23] Y. X. Zhou, F. B. Jin, M. Huang, T. H. Le, J. W. Huang, Z. H. Liu, and L. C. Lu, "Effects of thermal aging on creepage discharge in oil-impregnated pressboard under combined AC-DC voltage," *IEEE Trans. Dielectr. Electr. Insul.*, vol. 22, no. 5, pp. 2737–2746, Oct. 2015.
- [24] Y. X. Zhou, F. B. Jin, M. Huang, J. W. Huang, Z. H. Liu, and L. C. Lu, "Effects of DC prestressing on partial discharge in oil-impregnated pressboard insulation," *IEEE Trans. Dielectr. Electr. Insul.*, vol. 23, no. 1, pp. 460–468, Feb. 2016.
- [25] F. Jin, Y. Zhou, B. Liang, Z. Zhou, and X. Li, "Effects of temperature on characteristics of creepage discharge in oil-impregnated pressboard insulation under combined AC-DC voltage," in *Proc. 12th Int. Conf. Properties Appl. Dielectr. Mater. (ICPADM)*, Xi'an, China, May 2018, pp. 546–549.
- [26] F. B. Jin, Y. Zhou, B. Liang, Z. Zhou, and L. Zhang, "Effects of temperature on creepage discharge characteristics in oil-impregnated pressboard insulation under combined AC-DC voltage," *Plasma Sci. Technol.*, vol. 21, no. 5, pp. 14–22, Mar. 2019.
- [27] Y. Zhou, M. Huang, W. Chen, L. Lu, F. Jin, and J. Huang, "Space charge behavior evolution with thermal aging of oil-paper insulation," *IEEE Trans. Dielectr. Electr. Insul.*, vol. 22, no. 3, pp. 1381–1388, Jun. 2015.



JIN FUBAO (Member, IEEE) was born in Xining, Qinghai, China, in 1981. He received the B.E. and M.S. degrees in electrical engineering from the Harbin Institute of Technology, Harbin, China, in 2004 and 2007, respectively, and the Ph.D. degree from Tsinghua University, Beijing, China, in 2015. From 2007 to 2011, he was a Research Assistant with the Department of Electrical Engineering, Qinghai University, where he has been an Assistant Professor since 2018. He is currently

with Qinghai University. His research interests include dielectric insulation and surface discharge in transformer insulation systems.



ZHOU YUANXIANG (Member, IEEE) was born in Fujian, China, in 1966. He received the B.E. degree from Tsinghua University, Beijing, China, in 1988, the M.E. degree from the Electrical Power Research Institute, Beijing, in 1991, and the Ph.D. degree from Akita University, Akita, Japan, in 1999. From 1999 to 2000, he was a New Energy and Industrial Technology Development Organization Fellow of the National Institute for Resources and Environment, National Institute of

Advanced Industrial Science and Technology, Japan. He is currently a Professor with Tsinghua University. His research interests include organic and inorganic dielectrics, high-voltage technology and environmental protection, electrical equipment, and on-site detection and diagnosis.

Dr. Zhou is the Deputy Secretary-General of the China Electro Technical Society.



LIANG BIN was born in Xining, Qinghai, China, in 1984. He received the B.E. degree in electrical engineering from Northeast Normal University, Changchun, China, in 2006, and the M.S. degree in electrical engineering from Nanchang University, Jiangxi, China, in 2014. From 2006 to 2011, he was a Research Assistant with the Department of Electrical Engineering, Qinghai University. He is currently with Qinghai University. His research interests include control theory and applications, and artificial intelligence.

...