

Received January 17, 2021, accepted February 2, 2021, date of publication February 9, 2021, date of current version February 22, 2021.

Digital Object Identifier 10.1109/ACCESS.2021.3058117

Slope Stability Analysis Based on Leader Dolphins Herd Algorithm and Simplified Bishop Method

LI MA^{1,2}, JIANQIANG ZHAO³, JIANGUO ZHANG¹, AND SHUANGSHUANG XIAO¹

¹School of Energy Engineering, Xi'an University of Science and Technology, Xi'an 710054, China

²State Key Laboratory for Geomechanics and Deep Underground Engineering, China University of Mining and Technology, Xuzhou 221116, China

³School of Mathematics and Statistics, Xuzhou University of Technology, Xuzhou 221018, China

Corresponding authors: Li Ma (mali21786@hotmail.com) and Jianqiang Zhao (zjq076@126.com)

ABSTRACT According to the principles of bionics and predatory behavior of dolphins, Leader Dolphin Herd Algorithm (LDHA) was designed, whose performance is also tested on the basis of heuristic algorithm, showing that LDHA is obviously superior to the other algorithms in calculation accuracy and efficiency. The minimum safety factor of sliding surface was taken as the objective function, the recurrence formula of safety factor based on simplified Bishop Method was regarded as constraint condition, a non-linear multi-objective optimization mathematical model used for analyzing slope stability was established. The process of searching slope sliding surface and solving safety factor were designed on account of LDHA. By taking homogeneous slope and layered slope as calculation examples compared to other intelligent algorithms, the results show that the calculation result of LDHA is close to that of Genetic Algorithm and Simulated Annealing Algorithm and improved Genetic Algorithm. Moreover, the LDHA has less iterations and faster convergence rate, and the result is closer to the optimal solution, which indicates the feasibility and practicability of LDHA in solving the minimum stability safety factor.

INDEX TERMS Leader Dolphin Herd Algorithm, slope stability analysis model, Simplified Bishop Method, intelligence algorithm.

I. INTRODUCTION

Limit equilibrium method is the main method applied in slope stability analysis. By taking the process of calculating the safety factor for circular sliding surface of homogeneous slope as example, the safety factors of different assumptive sliding surfaces are calculated respectively, the one with the minimum safety factor is confirmed as the most dangerous sliding surface [1]–[3]. Bishop method is a very mature and practical limit equilibrium method for slope stability analysis, but the identification of the most dangerous sliding surface has directly influenced on calculation accuracy and iteration rate. In the traditional numerical calculation process, the center position of the most dangerous sliding surface can be narrowed to a certain range, but the amount of calculation could be huge, which brings difficulties to the solving process. However, the use of modern intelligent bionic algorithm can greatly improve the ability and speed of regional optimization.

The associate editor coordinating the review of this manuscript and approving it for publication was Yilun Shang¹.

Intelligent bionic algorithm based on bionics, mathematics and computer science, involving physics, physiology, neuroscience, control science, intelligence science, system science, social science, management science and many other disciplines, is a new optimization algorithm developed by imitating natural and biological phenomena, which has many characteristics and capacities, such as self-adaption, self-organization and self-learning [4], [5]. Artificial Neural Nets, Genetic Algorithm, Simulated Annealing Algorithm, Particle Swarm Optimization Algorithm and Ant Colony Algorithm are the most popular and representative algorithms at present [6]. Genetic Algorithm is mainly based on schemata theorem and building block hypothesis, and it can achieve the goal of finding the chromosome with maximum adaption through genetic manipulation of chromosome population [7], [8]. The basic idea of Simulated Annealing Method is to simulate the metal annealing process, using MetroPolis sampling method to calculate the optimal value of the objective function [9], [10]. The fundamental of Particle Swarm Optimization Algorithm is to simulate the foraging behavior of bird flocking or fish schooling, and to find the optimal solution through the movement of particle swarm

in the solution space by using Heppner model [11], [12]. Inspired by the positive feedback behavior of ants in searching for foraging path, Ant Colony Algorithm is established as a heuristic swarm intelligence optimization algorithm based on positive feedback [13]. Since different intelligent algorithms are constructed according to different hypotheses, each has its own operating conditions and limitations; they are all used to varying degrees in different optimization fields. The calculation speed and convergence rate are important indicators to determine the pros and cons of various intelligent algorithms.

According to the design principles of bionic intelligence algorithm and the stimulation of dolphins' predatory behavior, the most dangerous sliding surface range is determined based on the center of the circular sliding surface with the smallest safety factor is found by Leader of Dolphins Herd Algorithm (LDHA). Therefore, a method of slope stability analysis based on LDHA and Simplified Bishop (LDHA-SB) is established to determine the most dangerous sliding surface of side slope and calculate the safety factor. Meanwhile, comparing the results of LDHA-SB with the calculation results of Bishop, Genetic Algorithm (GA), and Simulated Annealing Algorithm (SAA), it has fewer iterations and faster convergence.

II. BASIC PRINCIPLES OF DOLPHIN HERD BEHAVIORS

During the course of communication and predation, dolphins could send out ultrasonic at frequency between 200 and 350 kHz, and surrounding sound-image would be established by analyzing echoes of their own ultrasonic, so as to determine the target's distance, direction, location, shape, and even nature of the object. Dolphins can communicate with each other, identify the path and prey collaboratively through the echolocation. According to the characteristics of the dolphin's behaviors, several basic principles in the predatory process of the dolphin herd are given as follows:

A. THE GENERATION OF A LEADER

Dolphins would build a 3D scene of the surroundings to determine the optimal location in the whole predatory space by noticing the time delay between producing echoes and detecting echoes, binaural time difference as well as the change of the loudness of echoes, as shown in Fig. 1(a). The dolphin in the global optimal position would become the leader of the entire dolphin herd and take on some challenging responsibilities, including in charge of herd agglomeration, segregation of duties and providing global information so that the herd members are able to exchange information.

B. HERD AGGLOMERATION

The leader of dolphins conveys the food location and relevant information by making sound, the whole herd would gather towards the center where the leader appears, i.e., the optimal position, as shown in Fig. 1(b). They would gradually evolve into a predatory herd and a virtual dynamic team consequently comes into being. Each dolphin does the same thing;

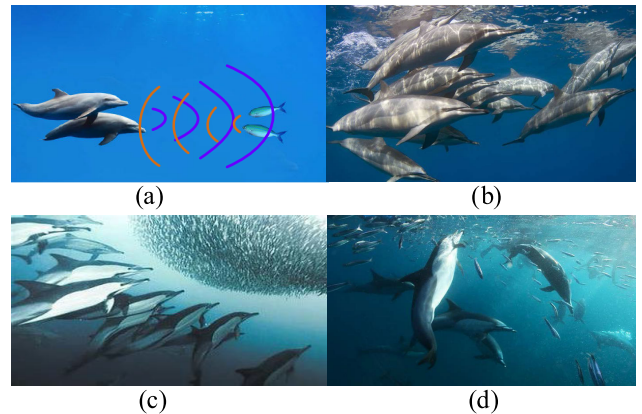

FIGURE 1. Basic principles of dolphin herd behaviors.

therefore, any dolphins in the optimal position can become the leader in each predatory process.

C. INFORMATION SHARING AND ROUNDING UP FOOD

In the agglomeration process, herd members can exchange information through echolocation and form an encirclement so as to obtain the maximum benefit in predation, as shown in Fig. 1(c). In the meantime, any dolphin who receives information may transfer it to its companion as well, therefore, the whole team can enjoy the maximum predatory information (or simplified as optimal information). After obtaining the optimal information, all herd members are capable of carrying out cooperation through the change of pulse loudness and emission rate, and then realize duty-division optimization and round up the food.

D. DUTY-DIVISION OPTIMIZATION

According to the information gathered from all directions, dolphins will be given different assignments through a comprehensive comparison and analysis of their information and positions. The one possesses the optimal location, the nearest distance and the best body functions will become the leader of the whole herd, as shown in Fig. 1(d).

III. THE DOLPHINS HERD ALGORITHM BASED ON LEADERSHIP STRATEGY

Based upon the predatory principle and method of the leader strategy, the entire process of dolphin herd's predation (as shown in Fig. 2) is finally realized through each dolphin's detection of the food features and environmental information, their mutual information sharing and interactions as well as individual behavioral decision-making concerning its duties.

The core connotation of LDHA is to analyze and process the predation information obtained through echolocation, and then then continuously search for the dolphins in the optimal position in an iterative way, that is, the leader of dolphins. The optimal position is precisely the solution of an optimization problem. The dolphin herd solves the optimization problem by means of a five-step process, including initializing the

herd, optimizing the duty-division, information sharing, herd following and rounding up and food distribution [14].

A. INITIALIZATION POPULATION

At this stage, the purpose is to make each dolphin distributed within the domain of objective function uniformly. Assuming that the size of dolphin herd is N , the dimension of searching space is D , so the position of the i_{th} artificial dolphin is:

$$\begin{aligned} X_i &= (x_{i1}, \dots, x_{id}, \dots, x_{iD}) \\ &= x_{\min} + \text{rand} \times (x_{\max} - x_{\min}) \end{aligned} \quad (1)$$

where, rand is a random number equally distributed within the range [0, 1], x_{\max} and x_{\min} are corresponding to bounds of searching space respectively.

B. DUTY-DIVISION OPTIMIZATION

Assuming that within the predation space of dolphin herd, every single dolphin can play the role of a guide. Initially, the entire herd of dolphins are randomly distributed in the predation space, but once one of them spots the sign of prey, it would act as a guide and convey the message to other dolphins through echolocation approach.

Upon receiving the message, the herd would start to look for their team members to form their own virtual team. In order to achieve the most accurate optimization results, the location of each dolphin can be assumed as $X_i (i = 1, 2, \dots, n)$ and then make respective calculation of X_{ij} , the distance between $X_j (j = 1, 2, \dots, n)$ and X_i (the distance between two dolphins could be obtained with their positional equation). After that, the distance results are sorted in an ascending order and dolphins that are closest are selected to form their virtual team.

The distance between every two dolphins could be calculated by:

$$X_{ij} = \sqrt{\overrightarrow{X_i - X_j} \cdot \overrightarrow{X_i - X_j}} \quad (i, j \in 1, 2, \dots, n) \quad (2)$$

A virtual team leader is determined by the local optimum of fitness function, while the leader of entire herd is selected from all virtual teams on the basis of the global optimum of fitness function. When dolphins are gathering towards their prey, there would be ceaseless iterations before reaching to the maximum one.

C. INFORMATION SHARING

Once the leader of dolphins is selected, it would share information with its herd members via sound so as to obtain their optimal location and fitness values. The information sharing activity could be repeated many times. Consequently, the advantageous dolphins would be soon perceived by other dolphins. This tactic allows the dolphin herd to approach and surround their prey orderly under the leadership of their lead and finally catch and feed on the prey.

D. HERD FOLLOWING AND ROUNDING UP FOOD

Having received food information from the guide dolphin, the leader dolphin would direct the rest of the herd to surround the food starting from the point where the leader itself is located. During the process of predation, effective position update by ordinary members plays a pivotal role. But whether to update their position or not is determined by a random number r_m which falls within the range of [0,1]. Specifically, if r_m is small than θ (a predefined threshold), the i_{th} dolphin will stop the update of the position. Otherwise, it is supposed to update position centring on the leader dolphin so as to encircle their food. Furthermore, loudness and pulse rate shall also be introduced hereunder. The loudness of the pulse $A(i)$ and emission rate $R(i)$ would update with the iteration process. Generally speaking, when approaching food, a dolphin's pulse loudness would gradually decrease and its emission rate increase. Therefore, $A(i) = 0$ means that the i_{th} dolphin has just spotted a prey and suspended making any sound. Formula (3) and (4) are equations for pulse loudness and emission rate update:

$$A^{t+1}(i) = \alpha' A^t \quad (3)$$

$$R^{t+1}(i) = R^0(i) \times [1 - \exp(-\gamma' t)] \quad (4)$$

where, $0 < \alpha' < 1$, $\gamma' > 0$ and both of them are constants. if $t \rightarrow \infty$, $A^t(i) = 0$, $R^t(i) = R^0(i)$, assuming that the dolphin's position is X_i^t at the time of t , and then the updated position X_i^t is:

$$X_i^{t+1} = \begin{cases} X_i^t & r_m < \theta \\ X_i^t + \varepsilon A^t(i) & r_m < \theta \end{cases} \quad (5)$$

where, ε is a D dimensions random vector whose range is [0, 1] and $A^t(i)$ is the pulse loudness when time is t . Since some ordinary dolphins could be located beyond the scope of predation, we would therefore repair the position coordinates after dolphins have surrounded the food:

$$x_{id}^{t+1} = \begin{cases} x_{\max} & x_{id}^{t+1} > x_{\max} \\ x_{\min} & x_{id}^{t+1} < x_{\min} \end{cases} \quad (6)$$

Once the leader dolphin's location is determined, the other herd members could be aware of their own location and fitness value through the information sharing. And on this basis, they could make further adjustment to their position before the orderly encirclement is finally completed. Until then, the global optimal value would be realized, which indicates the biggest predation benefits for the entire dolphin herd.

E. FOOD DISTRIBUTION AND RETURNING TO ORIGINAL STATUS

After completing an initial encirclement, the dolphins would further narrow it down by updating their location before finally preying on their food. As a matter of fact, the distribution of food does not depend on how much each dolphin contributes to the feeding activity. Instead, as soon as the

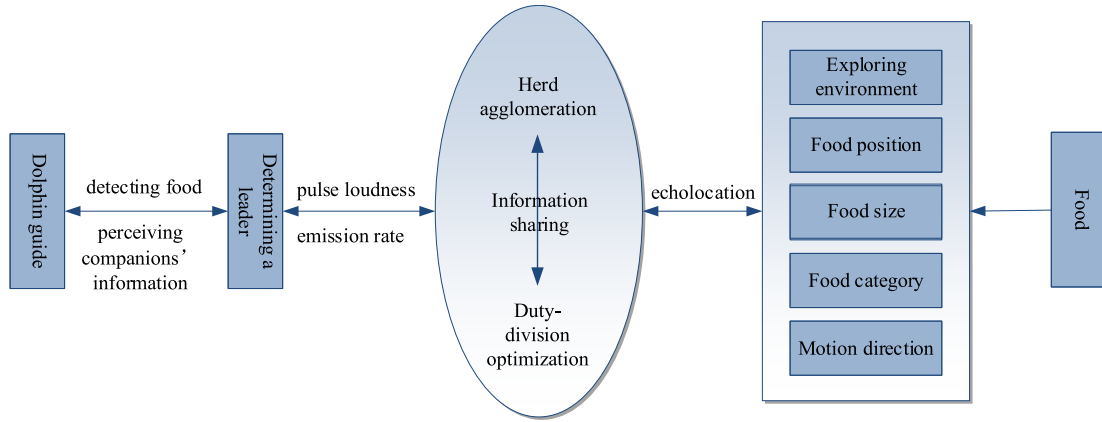

FIGURE 2. Dolphin prey model.

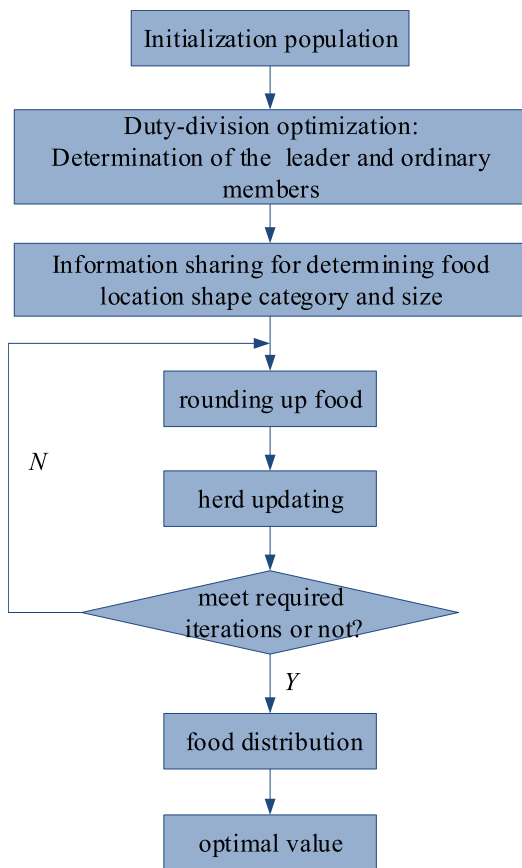

FIGURE 3. Flowchart of LDHA.

encirclement is made, those dolphins that have both the global and local optimal location would pause for a while so that the other ordinary dolphins could come along and prey on food altogether. When dolphins are done with this predation, they will resume the random manner in the space and wait for the next one. Flowchart of LDHA is shown in Fig. 3.

IV. METHOD OF SLOPE STABILITY ANALYSIS BASED ON SIMPLIFIED BISHOP

Assuming that the sliding surface is a quarter circular, the foot of a certain slope is taken as the origin, and a rectangular

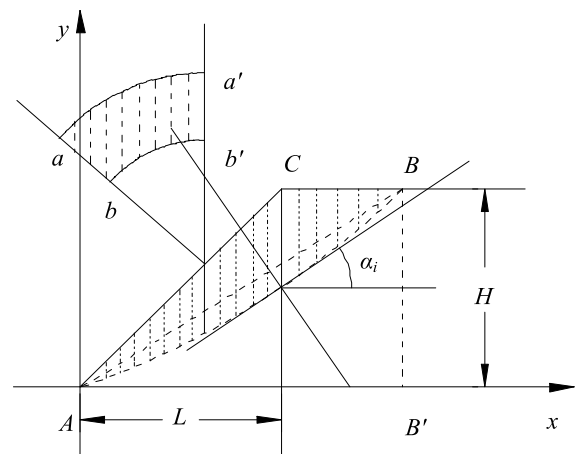

FIGURE 4. After-sliced schematic diagram.

coordinate is erected with Simplified Bishop Method. As well as the circular sliding surface AB is sliced, as shown in Fig. 4. Where, H represents slope height, m ; β represents slope angle, $^\circ$.

The slope safety factor of circular sliding surface can be calculated by:

$$FS = \sum_{i=1}^n \frac{1}{m_{\alpha i}} [W_i \tan \varphi_i + c_i l_i \cos \alpha_i] / \sum_{i=1}^n w_i \sin \alpha_i \quad (7)$$

$$m_{\alpha i} = \cos \alpha_i + \tan \varphi_i \sin \alpha_i / FS \quad (8)$$

where, w_i is the gravity of soil slice i ; φ_i is the internal friction angle of soil slice i in sliding surface; c_i is the cohesion of slice i in the sliding surface; l_i is the circular length of slice i ; α_i is the included angle between the tangent of the point in slice i circular and the horizontal line.

The coordinate range of the circle centre is within $aa'b'b'$, the variation range of the abscissa and ordinate of the centre are respectively obtained by [15]:

$$\begin{cases} X_{\min} = H(1/2 - 4 \sin \beta/4) / \tan \beta \\ X_{\max} = H / (2 \tan \beta) \\ Y_{\min} = H(1 + \cos^2 \beta / \sin \beta) / 2 \\ Y_{\max} = H/2 + 3H / (4 \tan \beta) \end{cases} \quad (9)$$

Assuming that the initial coordinates of the centre is (X_0, Y_0) , the radius is R_0 , since the circular sliding surface is crossing the slope angle, the radius can be calculated by:

$$R_0 = \sqrt{X_0^2 + Y_0^2} \quad (10)$$

The coordinates of the tension fracture point B is $(X_0 + \sqrt{R_0^2 - (H - Y_0)^2}, H)$, it can be obtained that:

$$AB' = X_0 + \sqrt{R_0^2 - (H - Y_0)^2} \quad (11)$$

The abscissa of the point in the i^{th} slice is:

$$\begin{cases} x_i = 0.5b_i + (i - 1)b_i \\ b_i = 0.1[X_0 + \sqrt{R_0^2 - (H - Y_0)^2}] \end{cases} \quad (12)$$

The equation of the curve between the slope ground and the tension fracture point can be expressed as:

$$f(x) = \begin{cases} x \tan \beta, & 0 \leq x < H \cot \beta \\ H, & H \cot \beta \leq x \leq AB' \end{cases} \quad (13)$$

Then the height of the i^{th} slice is:

$$h_i = f(x_i) - y_i = f(x_i) - \left(Y_0 - \sqrt{R_0^2 - (x_i - X_0)^2} \right) \quad (14)$$

The gravity of the i^{th} slice is:

$$w_i = \gamma \cdot b_i \cdot h_i \quad (15)$$

Since the slope of the circular in any point is $y' = -(x - X_0)/(y - Y_0)$, then $\alpha_i = \arctan(y'_i)$.

To solve the circular length of the i^{th} slice l_i , it is necessary to obtain coordinates of both endpoints of each soil slice, the abscissa and ordinate of which can be presented respectively as follows:

$$\begin{cases} xd_i = (i - 1) \cdot b_i \\ yd_i = Y_0 - \sqrt{R_0^2 - (xd_i - X_0)^2} \end{cases} \quad (16)$$

Thus, the angle between the line connecting the endpoints of slice and centre of circle and the vertical line crossing the centre can be presented as:

$$\alpha d_i = \arctan\left(-\frac{xd_i - X_0}{yd_i - Y_0}\right) \quad (17)$$

The corresponding central angle of each soil slice is:

$$circle_d_j = \alpha d_i - \alpha d_{i-1} \quad (18)$$

The circular length of each soil slice is:

$$l_i = circle_d_i \cdot R_0 \quad (19)$$

Supposing that there are n circular sliding surfaces coexisting, the safety factor of each surface is $FS_i (1 \leq i \leq n)$, then it is feasible to establish the following non-linear multi-target optimization mathematical model to determine

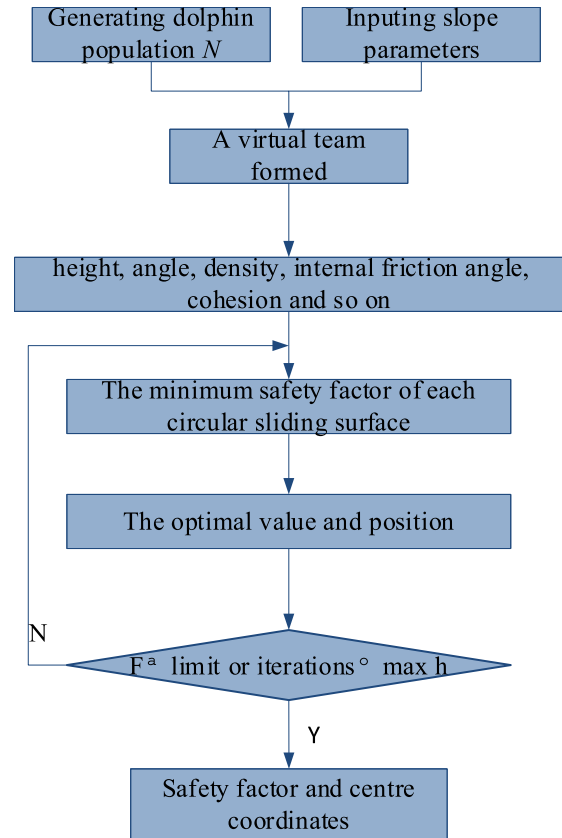

FIGURE 5. Flowchart of searching slope sliding surface with LDHA.

the most dangerous sliding surface and solve the safety factor:

$$\begin{aligned} & \min FS(FS_1, FS_2, \dots, FS_n) \\ & s.t. \begin{cases} FS_j = \sum_{i=1}^n \{ [W_i \tan \varphi_i + c_i l_i \cos \alpha_i] / m_{\alpha i} \} / \\ \sum_{i=1}^n W_i \sin \alpha_i \\ m_{\alpha i} = \cos \alpha_i + \tan \varphi_i \sin \alpha_i / FS_j \\ X_{\min} \leq x \leq X_{\max}, Y_{\min} \leq y \leq Y_{\max} \\ j = 1, 2, \dots, n \end{cases} \quad (20) \end{aligned}$$

V. THE MODEL OF APPLYING LDHA AND SIMPLIFIED BISHOP TO SEARCHING THE SLOPE SLIDING SURFACE

A. INITIALIZATION OF POPULATION

The initial dolphin population $N = (X_1, X_2, \dots, X_n)$ is generated randomly. The scale of dolphin population n is 20, the searching space D is 2, the limit value $Limit$ is 0.01, the maximum iteration time $\max h$ is 100, and then the position of the i^{th} artificial dolphin is:

$$\begin{cases} X_i = (x_{i1}, \dots, x_{id}, \dots, x_{iD}) \\ x_{id} = x_{\min} + \text{Rand} \times (x_{\max} - x_{\min}) \end{cases} \quad (21)$$

Rand is a random number even-distributed within the range $[0,1]$; dimension D is the coordinates position of the sliding surface centre; x_{\max} and x_{\min} are respectively corresponding to

TABLE 1. The comparison of LDHA, GA, POS and DPO.

FUNCTIONS	GA	PSO	DPO	LDHA
EASOM	19239±3307(92%)	17273±2929(90%)	3528±265(99%)	4519±405(99%)
MATYAS	52124±3277(98%)	69224±573(98%)	4923±448(98%)	7923±645(98%)
TRID6	55723±8901(90%)	32756±5325(98%)	34657±3675(99%)	33756±5345(100%)
SUMSQUARES	25412±1237(100%)	17040±1123(100%)	2156±317(100%)	1152±245(100%)
SPHERE	227329±7572(95%)	14522±1275(97%)	15378±6780(99%)	5715±678(100%)
BOOTH	89325±7914(95%)	43219±439(97%)	43579±537(100%)	4315±439(100%)
BOHACHEVSKY1	33929±1567(98%)	53247±472(90%)	6573±457(100%)	5379±472(100%)
EGGCRATE	524579±3369(97%)	45237±432(99%)	9765±613(99%)	8928±732(100%)
SCHAFFER	70925±7652(90%)	55970±4223(92%)	7657±4312(99%)	6957±2317(100%)
SIX CAMEL BACK	54077±4997(89%)	23992±3755(93%)	6789±4532(100%)	14537±3479(100%)
BOHACHEVSKY3	45796±2254(98%)	34578±342(93%)	78935±4537(99%)	7543±2096(100%)
BRIDGE	55643±4456(99%)	45329±235(94%)	4537±457(100%)	1068±756(100%)
RASTRIGIN	110523±5199(77%)	79491±3715(90%)	8967±6857(99%)	9792±5430(100%)
QUADRIC	67453±2199(89%)	37193±205(97%)	25789±4321(99%)	11756±3409(99%)
ACKLEY	32720±3327(90%)	23407±4325(92%)	67534±5674(100%)	27860±4325(100%)

the upper and lower limits of the searching space. Since many factors of slope shape parameters and rock mass mechanical parameters affect slope stability, such as height and angle (the ratio of vertical to horizontal slope), density, internal friction angle and cohesion. The slope parameters to be evaluated are inputted according to the requirements, and let the initial safety factor of the slope $k = 1$.

B. THE CONSTRUCTION OF THE VIRTUAL DOLPHIN TEAM

Each dolphin X_i ($i = 1, 2, \dots, n$) is defined as the centre, the distance d_{ij} between dolphin X_j ($j = 1, 2, \dots, n$) and dolphin X_i are calculated respectively. Then the distance is sorted in ascending order, m dolphins with nearest distance are selected and the virtual team is built. Among them, the computational formula of the distance between dolphins can be expressed as:

$$d_{ij} = \sqrt{(X_i - X_j)^2} \quad (i, j \in 1, 2, \dots, n) \quad (22)$$

Thus $Team(i, 1)$ usually refers to dolphin i itself, $Team(i, 2)$ to $Team(i, m)$ are its partners.

C. THE SELECTION OF FITNESS FUNCTION

During the calculation of the fitness value of each individual $fitness_i$, the position of the individual is regarded as the coordinates of the slope sliding surface centre. According to the constant iterations of Eq. (20), the deviation $[FS_{j+1} - FS_j]$ is controlled within a certain range, and the minimum value of slope safety factor FS_{min} is obtained, thus the fitness function of each dolphin can be obtained as:

$$fitness_i = FS_{j+1} - FS_j \quad (23)$$

D. THE JUDGMENT OF DOLPHIN'S ROLE IN THE TEAM AND DETERMINING THE OPTIMAL POSITION

On account of the fitness function, the fitness values of dolphins in each team are calculated, the optimal solution of each team $fxbest_i$ ($i = 1, 2, \dots, n$) and the optimal position p_{ii} ($i = 1, 2, \dots, n$), as well as the optimal solution of the population $fxbest$ and the optimal position p_{ni} are all determined.

E. UPDATE OF DOLPHINS' POSITIONS

As ordinary members in the team, the updating formula of dolphin individual can be expressed as:

$$x_i(t + 1) = x_i(t) + c_1r_1(p_{ii} - x_i) + c_2r_2(p_{ni} - x_i) \quad (24)$$

where, p_{ii} represents the optimal position of dolphin i in the whole team; p_{ni} represents the optimal position of dolphin population; c_i ($i = 1, 2$) is learning factor, whose value is generally 1.91445; r_i ($i = 1, 2$) is a random number within the range $[0,1]$.

F. $S \leq LIMIT$ OR ITERATION IS MORE THAN MAX H, THE TRAINING ENDS AND THE OPTIMAL POSITION OF DOLPHINS IS OBTAINED, OTHERWISE TURN BACK TO STEP (2)

G. THE OPTIMAL COORDINATES OF SLIDING SURFACE CENTER AND MINIMUM SAFETY FACTOR ARE ACQUIRED

The principle of searching sliding surface is shown in Fig. 5.

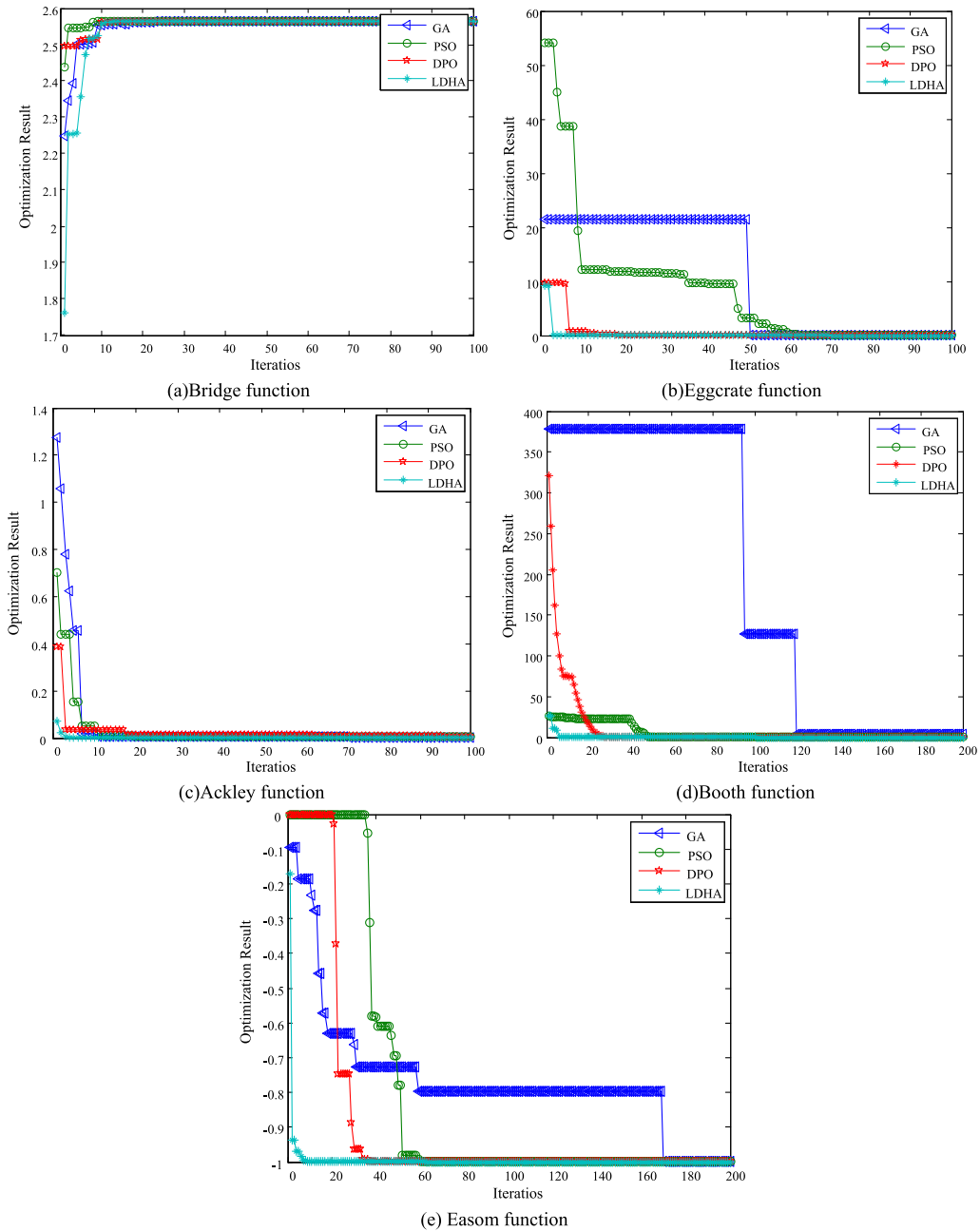

FIGURE 6. Convergence curves of different standard functions.

VI. RESULTS AND DISCUSSION

A. COMPARATIVE ANALYSIS OF THE ALGORITHMS

In order to identify the performance of LDHA, Genetic Algorithm (GA), Particle Swarm Optimization (PSO) and the Dolphin Partner Optimization (DPO) are tested comparatively [15]–[19]. Standard Genetic Algorithm is applied without elitist strategy, and the mutation probability is 0.05, the crossover probability is 0.95. In Particle Swarm Optimization algorithm, learning parameters is 2, inertia is 1. Around 10000 function values are needed during each operation; the run time is usually less than 5 second. In addition, it is found through the trials of different population quantity (n values

from 2 to 200) that for most problems, the value of n is within the range from 10 to 50. Therefore, n is assigned with a fixed value 40 in all simulations.

It can be seen from Table 1 that DOP is superior to GA and PSO in calculation accuracy and efficiency. While compared to DOP, LDHA introduces the idea of echolocation and makes it possible to further improve the speed and calculation accuracy by iteration with pulse loudness and emission rate.

For comparing the difference of LDHA to GA, PSO and DPO, the following convergence curves between iterations with objective function of five different standard functions were obtained by experiment, as shown in Fig. 6. And it can

TABLE 2. Stability results for homogeneity slope with different methods.

ALGORITHM	COORDINATES OF THE CENTER	RADIUS	SLOPE SAFETY FACTOR	ITERATION
BISHOP	(-0. 53, 44. 573)	44.575	1.661	50
GA-SB	(-12. 01, 36. 235)	38.173	1.316	40
SAA-SB	(-11. 52, 35. 612)	37.429	1.315	40
LDHA-SB	(-11. 85, 34. 214)	37.54	1.312	20

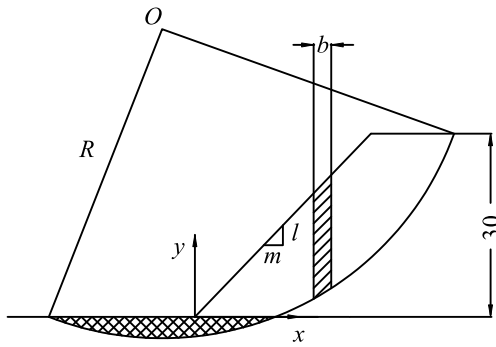

FIGURE 7. Schematic diagram of sliced method in homogeneity slope.

be observed that LDHA is superior to other algorithms in computational accuracy and convergence rate.

B. APPLICATION IN HOMOGENEOUS SLOPES

Taking the homogeneous slope in reference [21] as the example, LDHA-SB is tested and analysed in this example. The slope is full of homogeneous clay, the corresponding parameters of which are: cohesion $c = 60$ kPa, internal friction angle $\varphi = 30^\circ$, unit weight $\gamma = 18$ kN/m³, the height is 30 m, the slope ratio of perpendicular and horizon is 1: 0.58, as shown in Fig. 7.

The corresponding parameters are set according to the principles of applying LDHA-SB to searching sliding surface: the maximum iteration time $MAXGEN = 100$, the population size is 20; the number of partners is 6. The comparison between computational results acquired with MATLAB programming and the results taken from the reference are shown as in Table 2.

It can be drawn from the comparison that although the centre coordinates, radius and safety factor calculated by LDHA-SB are similar to those acquired with GA-SB or Simulated Annealing Algorithm, LDHA-SB has less iterations, faster convergence rate. Therefore, it is closer to optimal solution.

C. APPLICATION IN LAYERED SLOPE

Taking the layered slope in reference [22] as the testing target, the slope structure and relevant slope parameters of rock mass mechanics are respectively as shown in Fig. 8 and Table 3.

The corresponding parameters are set as follows: the maximum iteration time is 100, the size of population is 50, and the number of partners is 15. The comparative results are shown in Table 4.

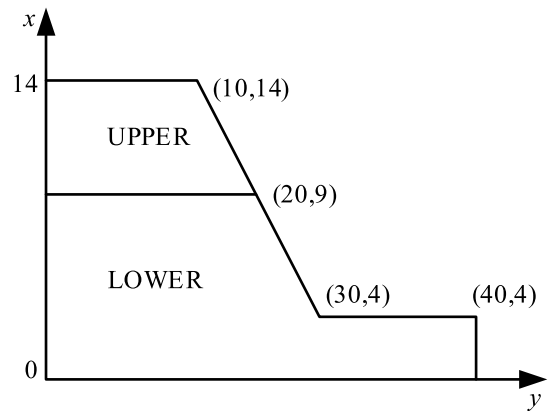

FIGURE 8. Structure diagram of layered slope.

TABLE 3. Rock mass mechanical parameters of layered slope.

PARAMETER	LAYER	
	UPPER	LOWER
ROCK FORMATION LOCATION	UPPER	LOWER
DENSITY(KN·M ⁻³)	15	15
COHESION(KPA)	5	8
INTERNAL FRICTION ANGLE(°)	20	25
HEIGHT(M)	5	5
THE SLOPE RATIO OF PERPENDICULAR AND HORIZON	0.5:1	0.5:1

TABLE 4. Stability results for layered slope with different methods.

ALGORITHM	SLOPE SAFETY FACTOR	ITERATION
GA-SB	1.153	100
SAA-SB	1.183	20
LDHA-SB	1.125	10

The result calculated with LDHA-SB is relatively close to the safety factor value which is gained by GA-SB in the reference. However, the iterations of LDHA-SB are less and the convergence rate of LDHA-SB is faster, which presents obvious superiority to GA-SB and SAA-SB.

VII. CONCLUSION

According to the principles of bionics, Leaders of Dolphin Herd Algorithm (LDHA) is designed, whose performance is tested based on heuristic algorithm. LDHA is obviously superior to the other algorithms in calculation accuracy and efficiency. Compared to the Dolphin Partner Optimization, LDHA introduces the idea of echolocation and makes it

possible to further improve the speed and calculation accuracy by iteration with pulse loudness and emission rate.

The minimum sliding surface safety factor is taken as the objective function, the recurrence formula of safety factor based on simplified Bishop method is regarded as constraint condition, as a result, a non-linear multi-target optimization mathematical model used for analysing slope stability is established, the searching and solving process of slope sliding surface on account of LDHA is designed. Based on these, a method of LDHA-SB is used to determine the most dangerous sliding surface of side slope and calculate the safety factor.

LDHA-SB is applied to analyse homogeneous and layered slope respectively, and it turns out that LDHA-SB has less iterations and faster convergence rate, which indicates the feasibility and practicability of LDHA in solving the minimum stability safety factor.

CONFLICTS OF INTEREST

The authors declare no conflict of interest.

REFERENCES

- [1] B. Jiang and W. Kang, "Analytical formulation of bishop's method for calculating slope stability," *J. China Univ. Mining Technol.*, vol. 37, no. 3, pp. 287–290, 2008.
- [2] Z. Liu and Z. Wang, "Method of determinating the location of center of critical circular failure surface," *J. China Coal Soc.*, vol. 22, no. 6, pp. 612–616, 1997.
- [3] D. Deng and L. Li, "Research on calculation methods of slope stability under two types of sliding surface," *Rock Soil Mech.*, vol. 34, no. 2, pp. 372–380 and 410, 2013.
- [4] K. Tang, "Modifications and application research on genetic algorithm and particle swarm optimization algorithm," Ph.D. dissertation, School Comput. Sci. Technol., Nanjing Univ. Sci. Technol., Nanjing, China, 2011.
- [5] H. Duan, S. Shao, B. Su, and L. Zhang, "New development thoughts on the bio-inspired intelligence based control for unmanned combat aerial vehicle," *Sci. China Technol. Sci.*, vol. 40, no. 8, pp. 853–860, 2010.
- [6] R. Govindaraju and A. Rao, *Artificial Neural Networks in Hydrology*. Dordrecht, The Netherlands: Springer, 2000.
- [7] S. Rajasekaran and G. Pai, "Neural networks, fuzzy logic and genetic algorithms synthesis and applications," PHI Learn. Private Ltd., New Delhi, India, Tech. Rep., 2003.
- [8] M. D. Vose and A. H. Wright, "The simple genetic algorithm and the Walsh transform: Part II, the inverse," *Evol. Comput.*, vol. 6, no. 3, pp. 275–289, Sep. 1998.
- [9] B. Cakir, F. Altiparmak, and B. Dengiz, "Multi-objective optimization of a stochastic assembly line balancing: A hybrid simulated annealing algorithm," *Comput. Ind. Eng.*, vol. 60, no. 3, pp. 376–384, Apr. 2011.
- [10] N. MetroPolis, A. Rosenbluth, and M. Rosenbluth, "Equation of state calculation by fast computing machines," *J. Chem. Phys.*, vol. 21, no. 6, pp. 1087–1092, 1953.
- [11] J. Kennedy and R. Eberhart, "Particle swarm optimization," in *Proc. IEEE Int. Conf. Neural Netw. (ICNN)*, Nov. 1995, pp. 1942–1948.
- [12] M. Moradi and M. Abedini, "A combination of genetic algorithm and particle swarm optimization for optimal DG location and sizing in dwastribution systems," *Int. J. Electr. Power Energy Syst.*, vol. 34, no. 1, pp. 66–74, 2012.
- [13] M. Reed, A. Yiannakou, and R. Evering, "An ant colony algorithm for the multi-compartment vehicle routing problem," *Appl. Soft Comput.*, vol. 15, pp. 169–176, Feb. 2014.
- [14] J. Zhao, K. Ge, and K. Xu, "A heuristic algorithm based on leadership strategy: Leader of dolphin herd algorithm (LDHA)," *J. Adv. Comput. Intell. Intell. Informat.*, vol. 19, no. 4, pp. 491–499, Jul. 2015.
- [15] L. Xu and J. T. Yang, "Universal operator of genetic operation and image restoration," *J. Circuits Syst.*, vol. 4, no. 3, pp. 80–85, 1999.
- [16] M. Mitchell, *An Introduction to Genetic Algorithms*. Cambridge, MA, USA: MIT Press, 1998.
- [17] D. Wang, J. Wang, and H. Wang, *Intelligent Optimization Methods*. Beijing, China: Higher Education Press, 2007.
- [18] J. Wang and D. Wang, "Experiments and analysis on inertia weight in particle swarm optimization," *J. Syst. Eng.*, vol. 20, no. 2, pp. 194–198, 2005.
- [19] J. Kennedy and R. Eberhart, *Swarm Intelligence*. New York, NY, USA: Academic, 2001.
- [20] W. Zeng, Z. Che, X. Li, and Y. Luo, "Analysis and implementation of surface mine slope stability based on bishop method," *J. Mining Saf. Eng.*, vol. 29, no. 2, pp. 262–270, 2012.
- [21] Z. He and S. Chen, "Application of mixed genetic-simulated annealing algorithms to slope stability analysis," *Rock Soil Mech.*, vol. 25, no. 2, pp. 316–319, Feb. 2004.
- [22] H. Wang, H. Guo, and Y. Zhang, "Modified genetic algorithm and its application to the stability analysis of side slope," *Periodical Ocean Univ. China*, vol. 37, no. S1, pp. 253–256, Jul. 2007.

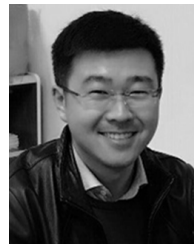

LI MA was born in Jixian, Shuangyashan, China, in 1986. He received the B.E. degree and the Ph.D. degree in mining engineering from the China University of Mining and Technology, Xuzhou, in 2010 and 2015, respectively.

From 2015 to 2017, he held a postdoctoral position with the State Key Laboratory for Geomechanics and Deep Underground Engineering, School of Mines, China University of Mining and Technology. He is currently working as an Associate Professor with the Xi'an University of Science and Technology. He has ten years of research experience in the area of surface mining optimization. He has authored or coauthored more than 50 publications.



JIANQIANG ZHAO was born in Jiangsu, Xintai, China, in 1980. He received the B.S. and M.S. degrees in mathematics from Shandong University, Jinan, in 2004 and 2007, respectively, and the Ph.D. degree in mining engineering from the China University of Mining and Technology, Xuzhou, in 2015.

From 2007 to 2016, he was a Lecturer with the Xuzhou Institute of Technology. Since 2016, he has been an Assistant Professor with the School of Mathematic and Physical Science, Xuzhou Institute of Technology. His research interests include statistics and intelligence algorithm.



JIANGUO ZHANG was born in Shanxi, Datong, China, in 1995. He received the bachelor's degree in mining engineering from the North China Institute of Technology, Beijing, in 2018. He is currently pursuing the master's degree with the School of Energy Engineering, Xi'an University of Science and Technology.

He is also studying in the area of intelligent algorithm optimization of surface mining.



SHUANGSHUANG XIAO was born in Feng, Xuzhou, China, in 1988. He received the B.E. degree from the China University of Mining and Technology, Xuzhou, in 2011, and the Ph.D. degree in mining engineering from the School of Mines, China University of Mining and Technology, in 2016.

Since 2017, he has been a Lecturer with the School of Energy Engineering, Xi'an University of Science and Technology. He is currently working as an Associate Professor with the Xi'an University of Science and Technology. He has published more than 20 research articles in refereed journals. His research interest includes surface mining optimization.

...