

Received November 27, 2020, accepted December 4, 2020, date of publication December 15, 2020, date of current version December 28, 2020.

Digital Object Identifier 10.1109/ACCESS.2020.3044882

# Medium Voltage Large-Scale Grid-Connected Photovoltaic Systems Using Cascaded H-Bridge and Modular Multilevel Converters: A Review

**AHMED ELSANABARY**<sup>1</sup>, **GEORGIOS KONSTANTINOU**<sup>2</sup>, (Senior Member, IEEE),  
**SAAD MEKHILEF**<sup>1,4</sup>, (Senior Member, IEEE),  
**CHRISTOPHER DAVID TOWNSEND**<sup>3</sup>, (Member, IEEE),  
**MEHDI SEYEDMAHMOUDIAN**<sup>4</sup>, (Member, IEEE),  
**AND ALEX STOJCEVSKI**<sup>4</sup>, (Member, IEEE)

<sup>1</sup>Power Electronics and Renewable Energy Research Laboratory, Department of Electrical Engineering, University of Malaya, Kuala Lumpur 50603, Malaysia

<sup>2</sup>School of Electrical Engineering and Telecommunications, University of New South Wales, Sydney, NSW 2052, Australia

<sup>3</sup>School of Electrical, Electronic and Computer Engineering, The University of Western Australia, Crawley, WA 6009, Australia

<sup>4</sup>School of Software and Electrical Engineering, Swinburne University of Technology, Melbourne, VIC 3122, Australia

Corresponding authors: Saad Mekhilef (saad@um.edu.my) and Ahmed Elsanabary (eng\_san88@eng.psu.edu.eg)

This work was supported in part by the Ministry of Higher Education, Malaysia, through the Large Research Grant Scheme (LRGS): LR008-2019, under Grant LRGS/1/2019/UKM/01/6/3; in part by the University of Malaya, Malaysia, through the Research Grant Impact Oriented Interdisciplinary Research Grant (IIRG), under Grant IIRG011A-2019; and in part by the Ministry of International Trade and Industry (MITI), Malaysia, through the MIDF under High Value Added and Complex Product Development and Market Program, under Grant GA016-2019.

**ABSTRACT** Medium-voltage (MV) multilevel converters are considered a promising solution for large scale photovoltaic (PV) systems to meet the rapid energy demand. This article focuses on reviewing the different structures and the technical challenges of modular multilevel topologies and their submodule circuit design for PV applications. The unique structure of the converter's submodule provides modularity, independent control of maximum power point tracking (MPPT), galvanic isolation, etc. Different submodule circuits and MPPT methods to efficiently extract the PV power are reviewed. The integration of the multilevel converters to PV systems suffers unbalanced power generation during partial PV shading conditions. Several balancing strategies to solve this problem are presented and compared to give a better understanding of the balancing ranges and capabilities of each strategy. In addition, the paper discusses recent research advancements, and possible future directions of MV converters-based large-scale PV systems for grid integration.

**INDEX TERMS** Multilevel converters, PV systems, modularity, balancing strategies, grid.

## I. INTRODUCTION

Among different distributed energy resources (DER)s, solar photovoltaic (PV) energy production is gaining an increasing share in the electricity market. Further growth is planned by many countries in an aim to achieve 100% renewable grid [1], [2]. These developments result in creation of new markets, installation of more GW power plants, and PV modules price decline [3], [4]. Global solar PV capacity has reached 627 GW driven by a growing number of residential and commercial installations, as well as utility scale projects [3]. New opportunities rise from hybrid solar PV-hydropower systems with floating solar PV modules where land area is limited [3].

The associate editor coordinating the review of this manuscript and approving it for publication was Xiaodong Liang<sup>id</sup>.

The common structure of large-scale PV power plant consists of solar PV modules, dc-dc converters, PV inverters, line filters, and a medium-voltage (MV) transformer. The PV inverter is considered the heart of the solar PV plant as it manages the power flow through the system and connection to the grid. Centralized PV inverter technologies have been commercially used in constructing large-scale PV plants for decades [5], [6]. However, they suffer from the low voltage/power ratings, and efficiency loss because of the centralized maximum power point tracking (MPPT) control [6]. Fig. 1 shows the common structure of the traditional large-scale PV power plant. The MV transformer is an essential part of the plant and its objective is to provide both galvanic isolation for the PV system and connection to the MV grid. Nevertheless, the use of bulky and heavy power transformers significantly increases the system cost, weight, and volume.

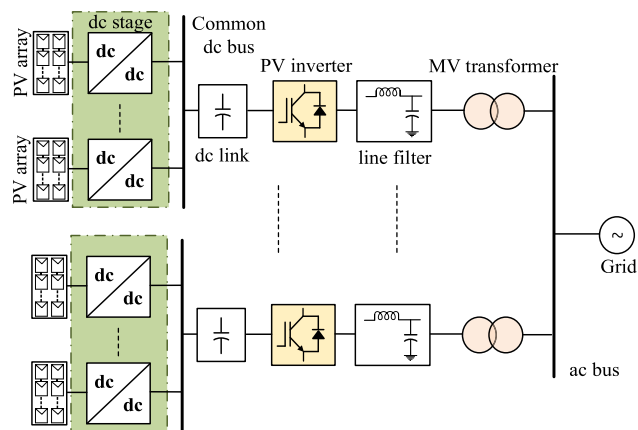

FIGURE 1. Typical structure of a large-scale PV power plant.

In an effort to achieve more voltage and power levels, multilevel inverters have been selected to replace the two-level inverter inside the PV plants. Three-level neutral point clamp (NPC) inverters are introduced for PV applications due to design simplicity and availability in the market. However, NPC topology requires a common DC link which reduces its modularity and efficiency of MPPT control. Moreover, the excessive number of clamping diodes with increasing the number of levels would be a main drawback for the MV grid applications [4], [6]–[8].

Hence, new modular structures of high-performance PV inverters are required to achieve modularity, higher efficiency, power density and voltage/power levels. As superior candidates, two main topologies of multilevel converters, namely Cascaded H-bridge (CHB) Converter and Modular Multilevel Converter (MMC), show outstanding performance by combining all the requirements of the new PV inverter structure. Both converters feature independent MPPT control, modular structure, can be directly connected to medium voltage grids, and higher efficiency compared to other multilevel topologies [4], [9], [10]. An essential part in these topologies is the submodule (SM) circuit in which the power flows from the PV modules to the inverter ac terminals. The design of the SM circuit should provide grounding of the PV arrays, efficient MPPT control, and high power density [11]. Despite the unique features of CHB and MMC, the power mismatch among the converter legs and cells during severe undistributed PV power generation is considered the major challenge for these topologies. The need to introduce a balancing strategy to alleviate this power mismatch and control the power flow of the converter has been of interest to the research community [12], [13]. While modular topologies are gaining more interest in research studies, their use is limited in industrial applications for large-scale solar PV systems.

This article focuses on reviewing recent advancements of PV-MV converters, their technical challenges and design requirements. Different multilevel converter configurations, SM circuit topologies, and MPPT control are investigated. The work also presents a comparative study on the different control methods and power balancing strategies.

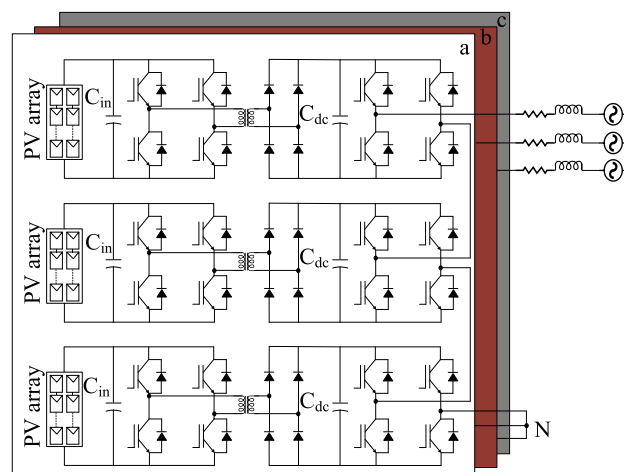

FIGURE 2. The structure of the Cascade H-bridge Multilevel Converter (Star configuration).

In Sections II and III, an overview of both the CHB and MMC topologies is provided. Then, an overview of different SM circuits and MPPT controls for the integrated PV arrays are explored in Section IV. In Section V, a comparative analysis on the performance of the balancing strategies applied for CHB and MMC topologies is conducted. Then, the paper discusses the recent advances and future trends related to the MV-PV plants in Section VI.

## II. THREE-PHASE CHB CONVERTER BASED PV SYSTEMS

The CHB converter topology is considered one of the most promising topologies among the multilevel converters family due to its unique structure [7], [14]. The CHB topology consists of several cascaded connected H-bridge cells with isolated dc power supplies as their input. The CHB topology is used for motor drives, static synchronous compensator (STATCOM), active power filter (APF), and battery storage applications [15]–[20]. The limitations of the CHB topology due to the need of multiple isolated power supplies, are an advantage for PV applications due to the ability of PV arrays to work as separate dc sources. The CHB converter offers modularity, scalability, and independent MPPT control. It has been proposed for various PV applications like low voltage grid-connected rooftops and MV large scale plants. The single-phase CHB converter is likely to be used for low voltage grid connections as proposed in [21]–[23], while the three-phase configuration is used for large scale PV systems as described in Fig. 2. The use of the CHB topology for PV applications was presented in three different configurations: separated PV modules, common magnetic link, and common dc link [24]–[35].

A large-scale grid-connected PV system with cascaded H-bridge cells connected to PV modules through isolated current fed dual active bridge (CF-DAB) dc-dc converters was proposed in [24], [25]. The CF-DAB converter was used to provide galvanic isolation and grounding of the PV arrays with more control degree-of-freedom. In addition, the authors proposed the use of film capacitors to reduce

large low-frequency dc voltage ripples coming from the PV converters. A three-phase MV Star-connected CHB converter using SiC-based isolated unidirectional cells for PV integration was presented in [26]. The use of a forward solid-state transformer (SST) based forward-DAB (F-DAB) eliminates the use of line-frequency transformer (LFT) and provides galvanic isolation to the PV arrays. Moreover, it is considered as a better solution compared to DAB converters since bidirectional power flow is not required for PV applications. The proposed F-DAB has superior characteristics (e.g., higher power density, lower costs) compared to other unidirectional converters [11].

In [27], [28], a three-phase CHB converter designed for PV integration to the grid was proposed. As shown in Fig. 2, the converter consists of nine H-bridge cells to generate a 7-level output voltage waveform. Each cell consists of PV modules connected to a unidirectional single active bridge (SAB) with a high-frequency transformer (HFT) to provide both insulation for PV arrays and higher voltage gain of the dc-dc converter. The converter was designed to work under unbalanced PV power generation. An alternative configuration for PV systems based on a Delta connection for the same CHB converter, presented in [29], expands the power balancing capabilities of the system compared to the Star connection converter. It also provides smaller voltage and current overrating to allow the operation of the converter under low irradiance conditions. In this sequence, [30] presented a modular MV single Delta bridge cell (SDBC) converter with low grid voltage ride-through capabilities for PV applications. The structure of the grid-connected PV Delta-connected clusters is depicted in Fig. 3. For each cluster, several cascaded H-bridge cells combined with isolated dc-dc converters directly transmit power from PV arrays to the grid terminals without the need for an LFT. The use of isolated dc-dc converters is to ensure the distributed MPPT control and grounding of the PV arrays. A further assessment of the system performance and balancing capabilities was discussed in [13], [31]. The voltage overrating in the Star configuration and the current overrating in the Delta configuration are the challenges faced by these systems.

The use of high-frequency magnetic links has been presented in [32], [33], [36]. However, the design and selection of the core are major concerns because of the high switching frequencies up to hundreds of kHz. In other words, core materials with high saturation flux density and low core loss is highly recommended. The development of amorphous and nanocrystalline magnetic materials has gained more interest in high power, high-frequency applications due to their enhanced electromagnetic characteristics [37]–[39]. In [32], a MV-CHB topology using a common high-frequency magnetic link for direct integration of PV sources was proposed. Several PV arrays are connected to the common HF link, which feeds the H-bridge cells of the converter using isolated dc sources. The proposed system can solve the problems of insulation of PV arrays, MPPT and voltage imbalances. However, it suffers from lower reliability and higher cost due

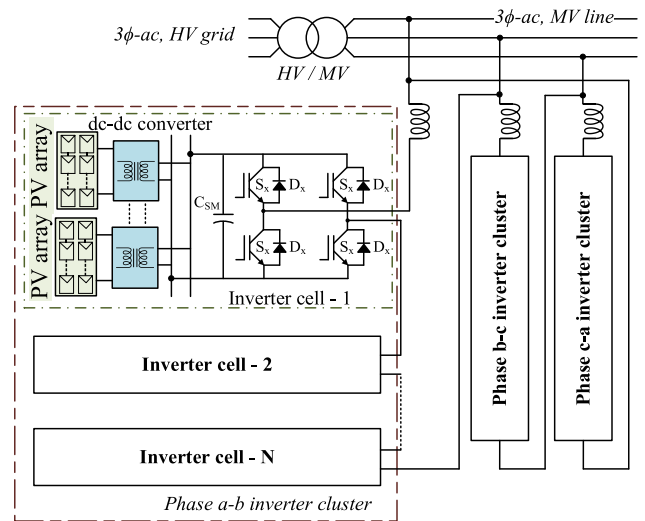

FIGURE 3. The structure of the Cascade H-bridge Multilevel Converter (Delta configuration).

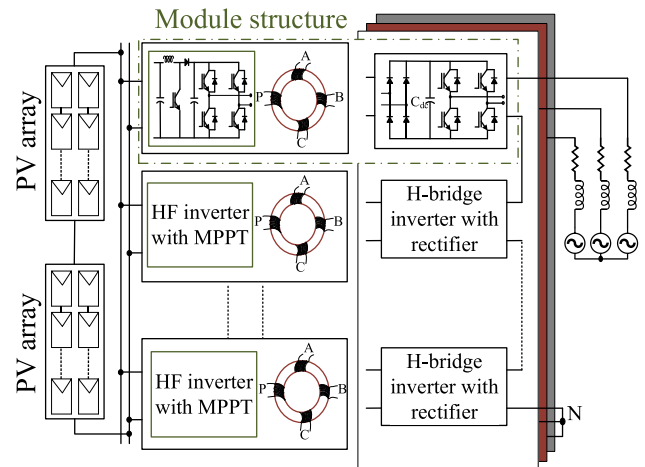

FIGURE 4. MV converter-based HF magnetic link for grid-connected PV plants.

to the non-modular structure and multiple power conversion stages. Moreover, the power ratings of the HF links are limited due to large leakage inductance. Instead of a high power magnetic link, the use of multiple low power HF magnetic links was proposed in [33] to solve the aforementioned problems. Fig. 4 shows the structure of a five-level, three-phase CHB topology for integration to MV grids. The H-bridges are connected with several high-frequency magnetic links that consist of one primary winding connected to the common dc source, i.e. PV arrays, and three secondary windings for the three-phase connection. The main challenge remains for the design and cost of the magnetic core.

A multi-string PV configuration with a common dc-link for large scale PV systems was proposed in [34] and experimentally validated in [35]. The system structure contains several PV strings along with their dc-dc converters connected to a common dc bus. Then, the common dc bus is used to energize the H-bridge cells of the grid-tied inverters through isolated

fly-back dc-dc converters. The system achieves galvanic isolation and independent MPPT but with comparatively lower system efficiency and higher cost due to the increased number of conversion stages. Moreover, compared to other isolated topologies, although fly-back converters are known by their economic and simple design, it suffers discontinuous output currents, which increase generated harmonics, and reduce the efficiency of the converter.

### III. THREE-PHASE MMC BASED PV SYSTEMS

The MMC, firstly proposed in [40], has been suggested as an alternative to other multilevel converters in many industrial applications like High voltage direct current (HVDC) transmission [41]–[43], industrial motor drives [44]–[46], and STATCOM [47], [48]. The MMC features modularity, scalability, fault-tolerant ride-through, and enhanced capability to deal with unbalanced conditions, compared to CHB topologies. The MMC topology consists of two arms per phase. Each arm has several SMs connected in series. Each SM typically consists of half bridge or full bridge cells. The MMC topology is considered as the evolution of CHB topology. The main difference in structure between MMC and CHB topologies is the existence of the common dc link and arm inductors [49].

The use of MMC for solar PV applications is currently investigated and yet to be an established technology compared to other applications. Research studies can be classified into projects which used MMC with a common dc-link and others that used it with separate PV arrays connected to their SMs. A single-phase MMC with a common dc link was presented in [50]. This article introduced a new capacitor balance control based on the concept of the virtual submodule (VSM) using the so-called selective virtual loop mapping control. This control allows voltage balancing for many SMs without an additional computational burden. This method is based on a continuous loop mapping change between the VSMs and the real SMs to equalize the capacitor voltages even with asymmetrical SMs. However, due to the usage of a centralized PV structure, the power generated under partial shading severely reduces because of Central MPPT and lower voltage ratings.

Reference [51] introduced a new circuit topology of the MMC for integrating PV distributed generation systems. Unlike conventional MMCs, arm inductors are replaced by an open-end transformer to reduce the electrical stresses on the MMC. By splitting the arm inductors into two windings, the proposed circuit can reduce each of the voltage rating of the power devices, the SM's capacitor size, and the required dc bus voltage from the PV plant. This modification reduces the complexity and dimensions of the converter. Yet, it uses the PV system as the dc-link of the MMC. The system still suffers from the central MPPT problem which affects the efficient use of all the power generated from the PV system.

A multi-string PV configuration using high gain dc/dc converters connected in parallel to construct a common dc-link as an input to the MMC was implemented in [52]. This system

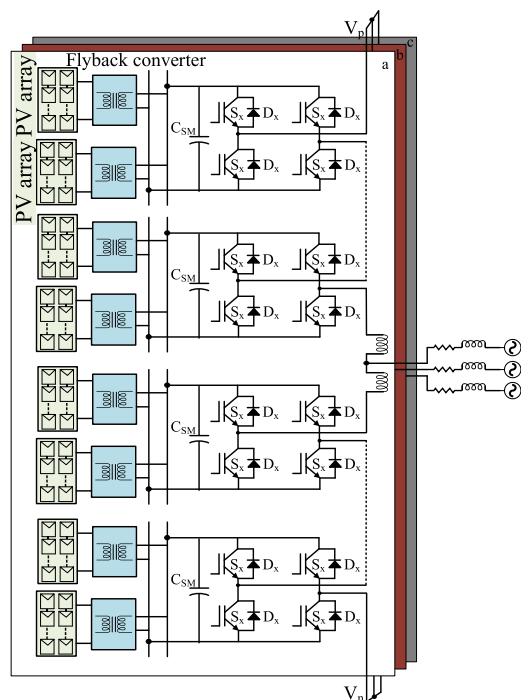

**FIGURE 5. The structure of Modular Multilevel Converter with distributed PV arrays and FB submodules.**

structure guarantees distributed MPPT among all PV strings and allows the application of conventional MMC topology and control. However, the shaded PV strings are enforced to work near MPP power as dc-link voltage should be kept constant. Furthermore, the use of boost converters does not provide galvanic isolation to the PV system which requires an LFT. The use of the transformer increases the cost and losses for the whole system. Also, the parallel connection of PV strings will limit the use of high dc-link voltages and adds more concerns about the use of MMC for such an application.

MMCs with solar PV integrated SMs have been proposed recently [53]–[55]. The MMC is becoming a potential candidate for the future of MV-PV plants due to its unique capabilities such as independent MPPT for PV modules, enhanced power quality, modularity, and scalability. Besides, it permits direct connection of the PV arrays to MV grids by adding more SMs connected in series, so the LFT is no longer needed. This topology may improve the efficiency and reduce the cost of the whole system [56], [57].

A three-phase MMC topology based on PV multi-strings connected directly to the SMs of MMC was presented in [53]. This multi-string configuration was used to achieve the advantages of MMC. The main challenge of this system is to mitigate power imbalance under any solar irradiance conditions. Fig. 5 shows the system structure of the MV-PV converter. For one SM, an isolated fly-back converter with PV power input is connected to the H-bridge cell to transmit PV power to the grid through the converter legs. However, the H-bridge cell is usually used for bi-directional power flow and dc fault ride through operations [57], which is not required for this configuration as PV power is unidirectional,



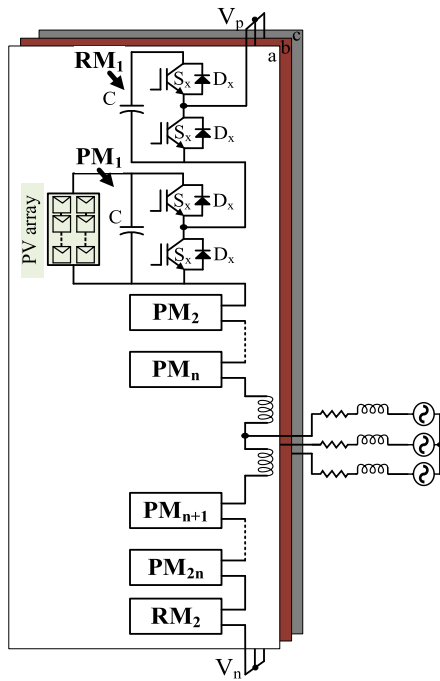

FIGURE 6. Modular multilevel converter for direct integration of PV arrays without dc-dc converter stage.

and the system has no common dc-link. The system provides distributed MPPT and galvanic isolation for the PV modules.

In [54], a new topology of MMC with PV arrays integrated into the SM was proposed. Fig. 6 shows the system structure which allows the independent MPPT control without the need of dc/dc stage which reduces the cost and losses of the system at the expense of galvanic isolation. The topology structure consists of several power modules (PM)s which are directly connected to the PV arrays. An extra redundant module (RM) was added to each arm to compensate for the SM voltage loss due to partial shading. The corresponding control can manage the multi-peak optimization problem of MPPT under partial shading conditions. The proposed structure may offer power balancing among the converter arms during partial shading conditions. Reference [55] proposed a MV-MMC for a PV system with power balancing capabilities. In the SM circuit, the authors used an isolated DAB dc-dc converter as a link between the PV modules and the half-bridge cell to ensure grounding of the PV modules and independent MPPT control. The use of DAB is not necessary for such a system due to the unidirectional power flow of the PV modules. Fig. 7 shows the circuit diagram of the proposed system. To summarize the above discussions, a comparison between different topologies to discuss their features is provided in Table 1.

#### IV. SUBMODULE TOPOLOGIES AND CONTROL

##### A. SUBMODULE CIRCUIT TOPOLOGY

An essential part of MV-PV multilevel converters is the submodule (cell) circuit. They are necessary to provide the galvanic isolation and distributed MPPT control to optimize the power transferred to the multiple converter cells. Thus, optimizing the circuit structure according to Solar PV module

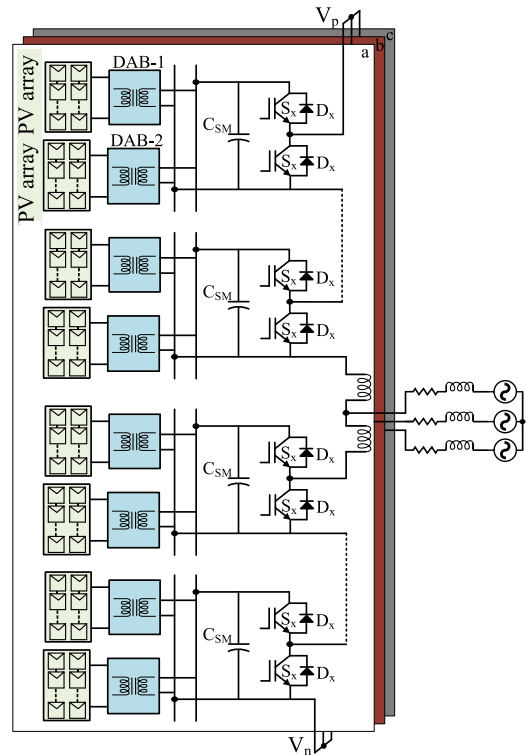

FIGURE 7. The structure of the PV modular MV converter with the isolated DAB.

TABLE 1. Comparison between Different MV Multilevel Converters for PV Systems.

Fig.	Topology used	Advantages	Drawbacks
Fig.2 [27]	Star-CHB	<ul style="list-style-type: none"> <li>•Modular and scalable design.</li> </ul>	<ul style="list-style-type: none"> <li>•Limited power balancing capability.</li> <li>•Voltage overrating.</li> <li>•Distorted voltage waveforms.</li> </ul>
Fig.3 [30]	Delta-CHB	<ul style="list-style-type: none"> <li>•Superior balancing capability.</li> </ul>	<ul style="list-style-type: none"> <li>•Current overrating.</li> </ul>
Fig.4 [33]	CHB	<ul style="list-style-type: none"> <li>•Elimination of power imbalance problem.</li> </ul>	<ul style="list-style-type: none"> <li>•Complex design due to HF magnetic links.</li> <li>•Less modularity due to Common dc link.</li> </ul>
Fig.5 [53]	MMC	<ul style="list-style-type: none"> <li>•Modular and scalable design.</li> </ul>	<ul style="list-style-type: none"> <li>•Low balancing capability.</li> </ul>
Fig.6 [54]	MMC	<ul style="list-style-type: none"> <li>•Good balancing capability.</li> </ul>	<ul style="list-style-type: none"> <li>•Extra cost due to redundant SMs.</li> </ul>
Fig.7 [55]	MMC	<ul style="list-style-type: none"> <li>•Superior leg balancing capability.</li> </ul>	<ul style="list-style-type: none"> <li>•Complex arm power imbalance control.</li> </ul>

requirements is a major concern for such systems. Due to the necessity of galvanic isolation as a main requirement for MV-PV plants, the use of an LFT was introduced despite its disadvantages [12]. Instead of using LFTs, HFTs were proposed to provide galvanic isolation. Recently, the advancement of silicon carbide (SiC) technology introduces the use of HFTs due to the superior performance of SiC switches in high switching frequency applications [58]. MV-PV plants use the isolated dc-dc converters with HFTs to provide both

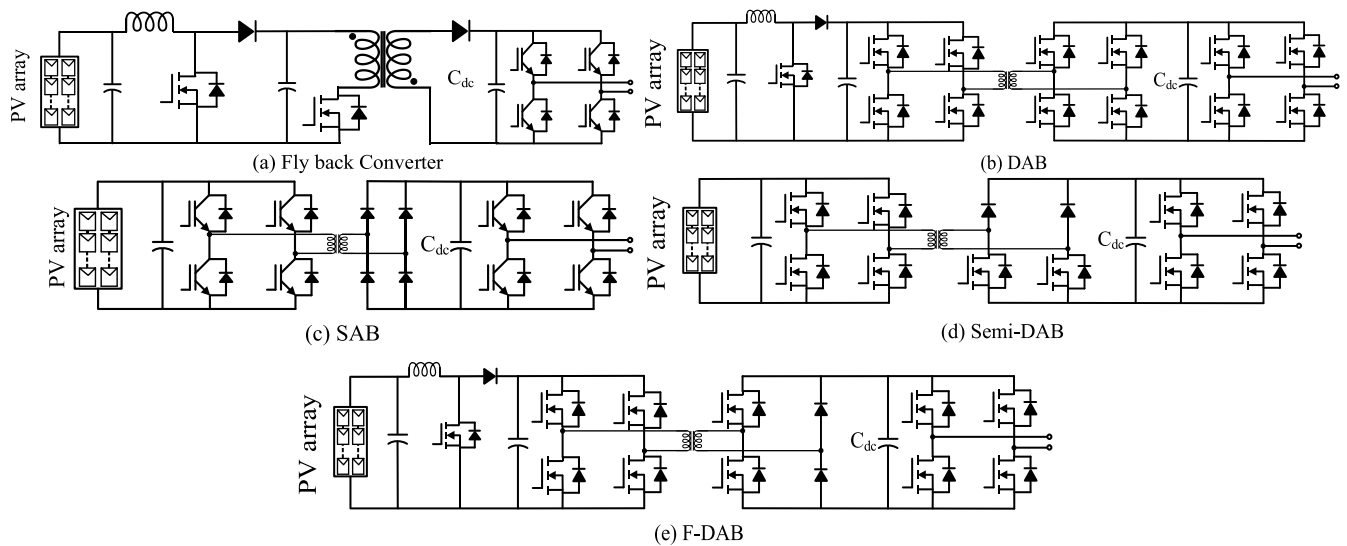

FIGURE 8. Different topologies of PV submodule (cell) circuits based modular MV converters.

TABLE 2. Comparison between Different SM Circuits.

SM Circuit	Switch count	Power density	Power flow	Circuit Features
Flyback [35]	1	Low	Uni-directional	<b>Advantages</b> <ul style="list-style-type: none"> <li>• Simple control.</li> <li>• Low cost.</li> </ul> <b>Disadvantages</b> <ul style="list-style-type: none"> <li>• Low power density.</li> <li>• Low conversion efficiency.</li> </ul>
DAB [63]	8	High	Bi-directional	<b>Advantages</b> <ul style="list-style-type: none"> <li>• High power density.</li> <li>• High conversion efficiency.</li> </ul> <b>Disadvantages</b> <ul style="list-style-type: none"> <li>• High cost.</li> <li>• Increased switching losses.</li> </ul>
SAB [27]	4	Medium	Uni-directional	<b>Advantages</b> <ul style="list-style-type: none"> <li>• Comparatively low cost.</li> <li>• Simple control.</li> </ul> <b>Disadvantages</b> <ul style="list-style-type: none"> <li>• Increased harmonic content.</li> <li>• Moderate power density.</li> </ul>
F-DAB [11]	6	High	Uni-directional	<b>Advantages</b> <ul style="list-style-type: none"> <li>• Compact design and low losses.</li> <li>• Comparatively high power density.</li> <li>• Suitability for PV SM circuits.</li> <li>• Same control of DABs.</li> </ul> <b>Disadvantages</b> <ul style="list-style-type: none"> <li>• Comparatively high cost compared to SAB and Flyback converters.</li> </ul>

galvanic isolation and unidirectional power flow as major requirements. The performance of these circuits can be evaluated by many aspects such as power density, part count, simplicity of control, power loss, and cost. Table 2 provides a comparative analysis of the different SM circuits used in PV-MV converters.

The fly-back converter is known for its simplicity and cost-effective structure and can be used for designing the PV

cells to provide both isolation and unidirectional power flow. However, it suffers from the large leakage inductance and discontinuous current operation which may deteriorate the conversion efficiency [59]. Reference [35] used the fly-back converter with a boost converter due to its simple control and less cost. The fly-back converter provides galvanic isolation while the boost converter is for MPPT cell control as shown in Fig. 8(a). The performance of the converter with multilevel converter cells has not been further explored in the literature. However, interleaved, high power, fly-back topologies have been proposed for PV grid-tied inverters which promotes their use in multilevel topologies [60], [61].

One of the popular topologies used in MV grid scale applications, where relatively high current and high power are required, are DABs. They are utilized as an interface between the PV arrays and the converter cell and feature high power density and simplicity of control with the ability of achieving zero voltage switching (ZVS) and high switching frequencies up to 1 MHz [62]. However, they have a comparatively large number of switches which contributes to higher cost and power loss. In addition, they provide a bidirectional power flow control which is not necessary in PV applications [12], [27]. A complete electrical and mechanical design of SiC voltage fed (VF)-DAB cell based PV-CHB converter (see Fig. 8(b)) was implemented in [63]. The proposed prototype uses the propylene film capacitors as a replacement of conventional electrolytic capacitors due to their comparatively long life time and adequacy to high frequencies (>10 kHz) [64], [65]. Nevertheless, the proposed control for VF-DAB in [63] requires a large transformer current which leads to more stress on the switches and saturation of the magnetic cores.

Reference [66] introduced a CF-DAB converter cell to limit the transformer current using a cascade control for both the CF-DAB and the full bridge inverter. The CF-DAB used an advanced phase-shift control to regulate the input PV voltage while the full bridge inverter controlled the

TABLE 3. Comparison between State-of-the-Art Modular MV Converters.

Ref.	Topology used	Common dc-link	No. of levels	Voltage and power rating	Independent MPPT control	Submodule circuit design	Galvanic isolation	Cell capacitor characteristics			Experimental validation
								Cell capacitance in mF	H-constant in ms	Cell voltage in Volts	
[24]	Star-CHB	×	5	120-V, 10-kW	✓	Isolated CF-DAB converter with FB cell	HF transformer	0.4	1.2	100	✓
[26]	Star-CHB	×	7	530-V, 6.183-kW	✓	Isolated F-DAB converter with FB cell	HF transformer	0.2	81.9	750	✓
[27]	Star-CHB	×	7	430 V, 8 kW	✓	Isolated Unidirectional-SAB converter with FB cell	HF transformer	18	272	164	✓
[29]	Delta-CHB	×	7	430 V, 10 kW	✓	Isolated Unidirectional-SAB converter with FB cell	HF transformer	18	462	239.4	✓
[30]	Delta-CHB	×	7	130 V, 12.6 kVA	✓	Isolated dc-dc converter with FB cell	N/A	46	43	36	✓
[32]	CHB	×	5	1 kV, 1.73 kVA	✓	Common HF link DAB converter with FB cell	Common HF magnetic link	---	---	---	✓
[33]	CHB	×	5	1.2 kV, 5 kVA	✓	Separate modules of HF link DAB converter with FB cell	Four identical HF magnetic links	---	---	---	✓
[35]	Star-CHB	✓	4	40 V, 225 VA	✓	Isolated fly-back dc-dc converters	HF fly-back transformer	2.2	25.4	24	✓
[50]	MMC	✓	5	115V, 1 kW	×	N/A	Line transformer	2.2	11	50	✓
[51]	MMC	✓	4	50V, 1kW	×	N/A	Line transformer	6	2.7	10	✓
[52]	MMC	✓	9	12.7kV, 9 MW	✓	N/A	Line transformer	---	---	1570	×
[53]	MMC	×	8	3.3 kV, 1.69 MVA	✓	Isolated dc-dc fly-back converter with FB cell	HF fly-back transformer	7.5	3.67	1000	×
[54]	MMC	×	3	380 V, 3 kW	✓	Half bridge cell (No dc stage)	N/A	2	180	300	✓
[55]	MMC	×	11	4.16 kV, 6 MW	✓	Isolated DAB converter with HB cell	HF transformer	10	16	800	×

output dc link voltage. The topology uses film capacitors and features inherent ZVS characteristics and minimized ripple effect. An optimized operation of the proposed topology was discussed in [67]. The unidirectional power flow nature of PV arrays leads the development of VF/CF-DABs. In this sequence, the research introduced SABs, Semi-DABs and Forward (F)-DABs, see Fig. 8(c), (d), (e), to be used in PV applications [11], [68]–[70]. These topologies permit the use of lower switch counts and reduce the cost of the converter cell compared to DABs. However, a compromise between power quality, efficiency, and costs should drive the topology selection. For instance, SAB is known as a simple and robust topology with a four-diode rectifier at the secondary side however it allows more harmonic content in the output current spectrum due to the absence of control at the converter secondary side. The efficiency of the converter is subsequently reduced.

In order to solve these problems, [69] proposed a semi-DAB to provide full controllability with only two active switches in the secondary side compared to DAB as shown in Fig. 8(d). However, the proposed topology was not deeply

studied or experimentally validated. A full analysis and design along with experiments for the semi-DAB was conducted in [70]. Compared to DAB, the semi-DAB offers extended ZVS range for output voltages with a lower number of active switches. On the other hand, a prototype of F-DAB as a part of the PV-CHB cell was designed in [11]. Compared to [63], The mechanical design volume of the converter cell is reduced by 50% which allows more compact design and reduces cost. Hence, the proposed F-DAB could realize an industrial prototype of the converter cell with remarkably high power density compared to other unidirectional topologies while maintaining the same control for classical DAB converters. From the above, it can be concluded that Semi-DAB and F-DAB topologies are suitable candidates for unidirectional power flow applications. However, a comparative study to evaluate the performance of each topology for the integration of PV arrays would be of interest.

Table 3 shows a comparative description between state-of-the-art modular MV converters including the cell capacitor characteristics. A useful and effective parameter in correlating capacitance value with its dc voltage is the unit

capacitance constant (H). Typically, H ranges from 1-20 ms, however higher values can be accepted depending on the type of application [71].

### B. MPPT CONTROL

The SM circuit for MV converters is utilized to perform the independent tracking control for PV arrays. The application of MPPT control can be performed through the dc-dc converter [24], [27], [29], [53], [55], or directly to the ac SM of the converter [54], [72]–[74]. Performing the MPPT control through isolated dc-dc converters provides both galvanic isolation and unidirectional power flow for the PV arrays [11]. Alternatively, the direct connection of PV arrays to the ac SM introduces the use of LFTs to isolate the PV array from the ac side and provide the connection to MV network. It eliminates the use of dc-dc converter which simplifies the circuit and control design. However, the use of bulky and heavy power transformers significantly increases the system cost, weight, and volume [12].

Different MPPT algorithms were applied to both MMC and CHB topologies such as Perturb and Observe (P&O) [35], [55], Incremental Conductance (InC) [75], and Ripple Correlation Control (RCC)[73], [76], etc. The P&O and InC algorithms are simple, robust, and well known in practical applications and have a good steady state performance. However, the tracking performance of both algorithms is affected with fast changes in environmental conditions which gives more delay in response to reach the steady state condition [77]. The use of RCC algorithm is also considered a suitable solution for modular multilevel applications due to its high dynamic performance, efficiency, and convergence speed to reach the MPP of the PV array [73], [76], [78]. For simplicity, typically all SMs utilize a common algorithm, although there might be opportunities in exploring whether combinations of different MPPT algorithms or tracking parameters may give improved performance, especially in hybrid applications.

In the typical SM circuit, the use of voltage and current sensors is required to perform both voltage balancing and independent MPPT control. However, increasing the level of the converter would introduce many sensors which significantly increases the cost and volume of the system, complicates the hardware with huge I/O interface controller ports, and decreases its reliability. To solve the problem, a simple P&O algorithm for CHB converter-based PV system for fast MPP tracking without the need for additional sensors or components was proposed in [79]. The MPP tracking was performed using the current measurements of the voltage and power of each SM which reduces the tracking errors during fast changes and extends the system scalability.

An optimized sensor-less predictive MPPT algorithm based on optimal model predictive control for MMC based-PV system was proposed in[80]. The algorithm is designed to deal with different shading conditions which allows for fast response to solar irradiance changes with high tracking efficiency compared to P&O and RCC algorithms.

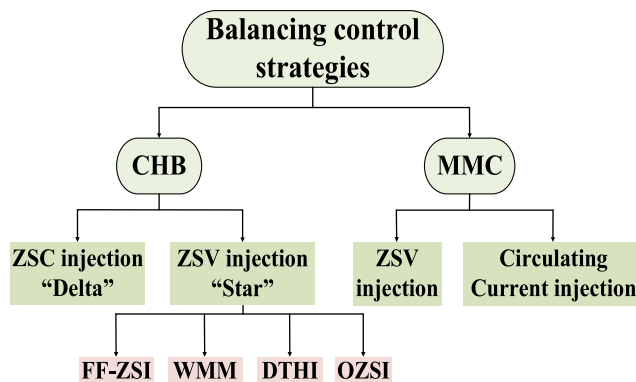

FIGURE 9. Commonly used balancing control strategies for modular MV converters-based PV systems.

Based on CHB converter-based PV system, a novel scheme of a sensor-less dc side control by estimating the SM capacitor voltages using the ac output voltage was proposed in [22]. The MPPT control was performed replacing all the individual voltage and current sensors at the dc side with a single voltage sensor at the ac side. This significant improvement features reduced cost, simple hardware, and higher reliability of the system.

### V. BALANCING CONTROL STRATEGIES

The operation of the MV converters-based PV distributed generation is highly dependent on the PV arrays contribution in different solar conditions. To explain this statement, these converters can guarantee a stable operation in balanced conditions where all the PV arrays share the same irradiance and output power. However, an unbalanced outflow of power can occur if different irradiances are subjected to the PV arrays, which can be observed in the unbalanced and distorted three phase grid currents. Hence, the MMC and CHB topologies share the same ultimate control objective to deliver the aggregate power from all PV arrays to the grid in a balanced way regardless of different power of the PV arrays. An energy balancing strategy should be activated when there are mismatches in the power delivered by the PV arrays to the converter ac side terminals through its SMs. The balancing strategy maintains the regulation between the input and output power flows through each SM to ensure a stable operation of all SM capacitors. The term of power imbalance in CHB converters can be classified into two categories: 1) The inter-bridge power imbalance, which occurs among the SMs in the same phase leg. 2) The inter-phase power imbalance, which occurs among the converter legs. On the other hand, The MMC structure adds a third category called the inter-arm power imbalance, which occurs among the arms of the converter leg. Fig. 9 presents the power balancing strategies used for MV converters-based PV systems.

#### A. POWER BALANCING STRATEGIES USING CHB TOPOLOGY

In grid connected PV systems using CHB topology, the power imbalance problem has gained a major interest in literature. The power fluctuations caused by this problem may affect



the grid stability. To solve the inter-bridge power imbalance in CHB topology, different control strategies were proposed to achieve power balancing between cells, independent MPP trackers of dc link voltages for each cell, high efficiency and system stability for all the PV arrays operating conditions [21], [81], [82]. In addition to the advances in control strategies, improving modulation techniques provides cell-mismatch capabilities by creating various routes for power flow among converter cells [83], [84]. In fact, better modulation techniques may add extra features to the converter like fault isolation capability, reduced harmonics and higher degree of freedom for control and operation [85]–[87].

Moreover, Multiport dc-dc converters have been reported to solve the inter-bridge power imbalance for CHB PV systems [66], [88]. An interleaved-boost full-bridge dc-dc converter with a common low-voltage dc link was proposed to solve both the inter-bridge and the interphase power imbalances [88]. Alternatively, hybrid cells were integrated to the CHB topology using batteries or super capacitors to alleviate the power mismatch between CHB cells [89]. However, the hybrid integration requires advanced control techniques to coordinate between hybrid cells.

For the inter-phase power imbalance, zero sequence voltage (ZSV) injection methods have been developed for Star-connected CHB converter while Delta-connected CHB converter uses the zero-sequence current (ZSC) injection method. A variety of ZVS injection methods to maximize the balancing capabilities under severe power imbalance conditions were proposed. They can be classified as follows:

- 1) Fundamental frequency zero sequence injection (FF-ZSI) method, originally proposed in [90].
- 2) Weighted min max (WMM) zero sequence injection method [91], [92].
- 3) Third harmonic square wave injection [13].
- 4) Double 1/6 third harmonic injection (DTHI), Reduced third harmonic injection (RTHI), and Double min–max (DMM) zero-sequence injection methods [27].
- 5) Optimal zero-sequence injection (OZSI) and Simplified-OZSI (S-OZSI) [28].

Despite several attempts to widen the power balancing capability of Star-connected CHB converter, the degree of power balancing for these methods are limited to the available dc link voltage in each phase. For the best scenarios (i.e. OZSI), the balancing capability cannot exceed 20% of power imbalance [93]. Moreover, the balancing process of the grid current affects the converter voltage spectrum which leads to more grid interactions [55]. During severe power imbalance, the converter voltage exceeds the dc voltage limits (i.e. over-modulation) and the grid currents are distorted [13].

The Delta-connected converter is then proposed in [29]. The Delta configuration offers high power balancing capabilities compared with the Star configuration. A ZSC injection method is used to rebalance the grid current during power imbalance conditions. The injected zero sequence current vector contributes to the power transfer between the phases. The only limiting factor is the maximum current rating that

flows through each cell of the connected H-bridges. Any increase in the power imbalance results in an increase of injected ZSC required to rebalance the line current [13]. It is recommended to provide 15% overcurrent rating in each cell while designing the converter.

## B. POWER BALANCING STRATEGIES USING MMC TOPOLOGY

The power balancing strategies in MMC utilize the distinctive feature which is the internal power flow of the converter. Unlike the conventional MMC, the integration of PV arrays to the SMs of the converter, see Fig. 5, eliminates the existence of DC-link which raises the need to advance the control strategies of the converter. The MMC topology experiences three categories of power imbalance (i.e. inter-bridge, inter-phase, inter-arm). A voltage compensation method, based on the modified min-max ZSI method proposed in [91], to solve the inter-phase power imbalance by injecting a ZSV into the phase voltage references of the MMC was discussed in [53]. However, the system suffers from voltage over-modulation when the generated power is heavily unbalanced. Moreover, it can only mitigate the inter-phase power imbalance but fails to eliminate the inter-arm power imbalance.

Reference [55] achieved the power balancing through introducing a power mismatch elimination strategy which ensures that one third of the whole PV power generation should flow through each phase of the converter. Moreover, the average power which leaves the ac-side terminals of each SM should be equal to the aggregate power delivered by the PV arrays integrated to that SM. The dc component of circulating current ( $i_{dc}^*$ ) is responsible for regulating the power mismatches between legs by keeping their energy equal to ensure that one third of the power is flowing in each leg. The ac fundamental frequency component of circulating current ( $i_{ac}^*$ ) is responsible for regulating the power mismatches between arms of the same leg by minimizing the energy difference between them. To alleviate the inter-bridge power imbalance, the sorting algorithm based on voltage and current measurements was implemented in [55]. Alternatively, it is remarked that the same balancing methods applied for CHB converter can be used for MMC due to the similarities between their SM structures [53], [94].

## C. POWER BALANCING CAPABILITY FOR THE INTER-PHASE POWER IMBALANCE

In Star-connected CHB topology, The ZSV injection methods cause a change in the reference voltages of each phase. Thus, under severe power imbalance, the voltage references should not exceed the maximum allowable dc link voltage for each cell. On the other hand, Delta-connected CHB converter examines a change in the phase current while applying a ZSC injection during power imbalance. These changes may cause a voltage over-modulation (in case of ZSV methods) or a current over-rating (in case of ZSC method) which consequently affects the balancing process. The ability of the ZSI method to deal with the power imbalance defines the power balancing capability.

**TABLE 4. Comparison between different injection methods.**

Injection method	Converter topology	Balancing range	Balancing limitations
weighted min max (WMM) [91, 92]	Star-CHB	Low	<ul style="list-style-type: none"> <li>The maximum available dc-link voltage.</li> <li>Inaccurate voltage reference</li> </ul>
double 1/6 third harmonic injection (DTHI) [27]	Star-CHB	Low	<ul style="list-style-type: none"> <li>The maximum available dc-link voltage.</li> </ul>
Optimal zero-sequence injection (OZSI) [28]	Star-CHB	Medium	<ul style="list-style-type: none"> <li>The maximum available dc-link voltage.</li> <li>Control complexity.</li> </ul>
ZSC injection [29]	Delta-CHB	High	<ul style="list-style-type: none"> <li>The maximum module current.</li> </ul>
ZSV injection [53]	MMC	Low	<ul style="list-style-type: none"> <li>The maximum available dc-link voltage.</li> <li>Arm power imbalance.</li> </ul>
Circulating current injection [55]	MMC	High	<ul style="list-style-type: none"> <li>Imbalance energy loss.</li> <li>Severe arm power imbalance.</li> </ul>

A three-dimensional (3-D) figure, called a power balance space (PBS), represents the utilized portion of the three-phase power based on the nominal power of the converter [95], [96] during the power imbalance conditions. The power balancing capability can be identified using only one factor called a power balance factor (PBF) as a function of the three-phase power ratios. Another method to compare the power balancing capabilities of ZSI methods with both qualitative and quantitative metrics was proposed in [13]. A two-dimensional (2-D) energy balancing diagram (EBD) represents the increase of the maximum voltage reference of any phase because of the power imbalance (qualitative metric). The quantitative metric calculates the area coverage of power imbalance in percentage as a function of the available dc link in one phase. However, this metric does not provide a direct measure of all the possible power imbalance cases [93].

Using the same definitions, the energy balancing capability for the Delta-connected CHB converter can be calculated [13], [29]. An added factor for this converter is the current overrating which identifies the maximum required switch rating. It can be determined as the ratio between the maximum and the nominal phase currents. An increase in the current rating of the switches with 15 % of the rated current is recommended. Table 4 shows the performance of different injection methods and their limitations.

## VI. RECENT ADVANCES IN MV-PV CONVERTERS

### A. ADVANCED GRID SUPPORT FUNCTIONS

Grid connected PV inverters are required to meet local standards and grid codes in order to achieve a high-quality signal of voltage and current supplied to the grid. Some constraints like harmonic current limits, maximum total harmonic

distortion (THD) of current, dc current injection, and operating frequency range should be strictly followed [97]. Certain grid codes obligate grid connected PV inverters to deliver reactive power to the grid. PV inverters should stay connected and be able to provide dynamic grid support during symmetric and asymmetric voltage sags and faults [30]. However, the grid support is determined by two factors: (1) the depth of voltage sags, and (2) the fault duration. Another aspect is the current rating of the inverter, thus during reactive current injection, the active current can be sufficiently reduced.

With the expected increase of renewable energy production in the near future, the number of inverter-based power generation may exceed 50% of the total power capacity which will form new inverter dominated grids [2], [98]. This inevitable evolution will lead the transition from “grid-following” inverters, which are currently used in the grid, to “grid-forming” inverters, which have the ability to stabilize the grid voltage and regulate the frequency [10].

### B. HYBRID INTEGRATION WITH DIFFERENT DERS

PV systems have an intermittent nature which reduces the efficiency and performance of the output power. This nature can be observed in nonuniform solar irradiance, unequal ambient temperatures, partial shading, and/or inconsistent module degradation [27]. The hybrid integration of DERS in the MV grid-connected PV converters has many advantages related to resilience and power quality of large-scale PV systems. This hybrid integration can be either through batteries or ultra-capacitors to provide peak power shaving, frequency regulation, and dynamic voltage support [99]. Battery energy storage systems (BESS) have been integrated with two level PV inverters in small scale PV applications. However, large battery modules, low interface voltage, low reliability and large volume are the disadvantages which limit the application to large-scale PV applications [100].

Multilevel converters such as the CHB and MMC topologies are superior candidates for such integration combining the advantages of enhanced power quality using PV-BESS systems and application to higher power and voltage ratings. The use of CHB and MMC topologies provides a hybrid structure as each SM can be integrated with PV arrays, BESS or both. Thus, this integration offers greater flexibility in control and power flow along with various features such as dynamic voltage support, fault ride-through capability, etc. Moreover, MMC topology has become a well-established technology in HVDC applications which extends its use if DERS are integrated to the converter SMs while transmitting the power from remote locations (e.g. solar and wind farms) to the ac side [10], [101]. Power imbalance and energy management strategies can be designed to arrange the operation of the hybrid integrated-DERS systems.

### C. CHALLENGES RELATED TO POWER BALANCING STRATEGIES

Various power balancing strategies proposed for PV-MV converters have been discussed in Section V. However, challenges to further improve the performance of these converters

during different power imbalance conditions remain open. For instance, Further investigations and experiments for the inter-bridge power imbalance strategies for both CHB and MMC topologies would be of interest. Also, there is a need to study the measures and limitations of the proposed strategies. In this sequence, the effectiveness of the sorting algorithm for the MMC topology to maintain the voltage balance between SMs during the inter-bridge power imbalance has not been fully addressed. In fact, under severe inter-bridge power imbalance, the sorting algorithm may lose its function as submodules with lower voltage will always be inserted which elevates the stress on the switches.

The proposed balancing strategies based on ZSI for Star-CHB converters have shown a limited power balancing capability during severe power imbalance conditions, which results in a total shut down of the system. Further investigations would be beneficial to expand the converter balancing range. Another challenge for the MMC topology is the inter-arm power imbalance during severe partial shading conditions. The need to generate the circulating ac current may cause power oscillations, and dc offsets in grid currents as the power balance between the arms cannot be totally guaranteed. Control strategies to cope with these conditions would be of interest.

## VII. CONCLUSION

In this review, a comprehensive study for the modular MV converters-based large-scale PV systems has been provided. The CHB and MMC topologies are found to be promising candidates for the future of the MV large-scale PV systems due to their modular structure. Following the design requirements of the SM circuit, the F-DAB is considered the most suitable topology featuring high power density and unidirectional power flow with reduced switch count. Sensor-less methods to apply MPPT are reliable, efficient, and cost wise compared to traditional methods. However, potential future research regarding SM circuit design and MPPT control would be of interest. The power balancing capabilities and limitations for the balancing strategies of different topologies have been investigated. Despite numerous balancing strategies proposed for Star-connected CHB topology, Delta-connected CHB topology and MMC topology have shown a superior performance during unbalanced PV power generation. The potential of the Modular MV-PV converters and the recent advances in the field should drive this technology to be commercially viable in solar PV systems.

## REFERENCES

- [1] M. Liserre, T. Sauter, and J. Hung, "Future energy systems: Integrating renewable energy sources into the smart power grid through industrial electronics," *IEEE Ind. Electron. Mag.*, vol. 4, no. 1, pp. 18–37, Mar. 2010.
- [2] B. Kroposki, B. Johnson, Y. Zhang, V. Gevorgian, P. Denholm, B.-M. Hodge, and B. Hannegan, "Achieving a 100% renewable grid: Operating electric power systems with extremely high levels of variable renewable energy," *IEEE Power Energy Mag.*, vol. 15, no. 2, pp. 61–73, Mar. 2017.
- [3] REN21. *Renewables 2020 Global Status Report*. Accessed: Jun. 16, 2020. [Online]. Available: [https://www.ren21.net/wpcontent/uploads/2019/05/gsr\\_2020\\_press\\_release\\_en.pdf](https://www.ren21.net/wpcontent/uploads/2019/05/gsr_2020_press_release_en.pdf)
- [4] X. Zhang, T. Zhao, W. Mao, D. Tan, and L. Chang, "Multilevel inverters for grid-connected photovoltaic applications: Examining emerging trends," *IEEE Power Electron. Mag.*, vol. 5, no. 4, pp. 32–41, Dec. 2018.
- [5] R. Hasan, S. Mekhilef, M. Seyedmehmoudian, and B. Horan, "Grid-connected isolated PV microinverters: A review," *Renew. Sustain. Energy Rev.*, vol. 67, pp. 1065–1080, Jan. 2017.
- [6] S. Kouro, J. I. Leon, D. Vinnikov, and L. G. Franquelo, "Grid-connected photovoltaic systems: An overview of recent research and emerging PV converter technology," *IEEE Ind. Electron. Mag.*, vol. 9, no. 1, pp. 47–61, Mar. 2015.
- [7] L. Franquelo, J. Rodriguez, J. Leon, S. Kouro, R. Portillo, and M. Prats, "The age of multilevel converters arrives," *IEEE Ind. Electron. Mag.*, vol. 2, no. 2, pp. 28–39, Jun. 2008.
- [8] O. P. Mahela and A. G. Shaik, "Comprehensive overview of grid interfaced solar photovoltaic systems," *Renew. Sustain. Energy Rev.*, vol. 68, pp. 316–332, Feb. 2017.
- [9] F. Shahnazian, J. Adabi, E. Poursmaeil, and J. P. S. Catalão, "Interfacing modular multilevel converters for grid integration of renewable energy sources," *Electr. Power Syst. Res.*, vol. 160, pp. 439–449, Jul. 2018.
- [10] F. Briz, M. Lopez, A. Rodriguez, and M. Arias, "Modular power electronic transformers: Modular multilevel converter versus cascaded H-bridge solutions," *IEEE Ind. Electron. Mag.*, vol. 10, no. 4, pp. 6–19, Dec. 2016.
- [11] T. M. Parreiras, A. P. Machado, F. V. Amaral, G. C. Lobato, J. A. S. Brito, and B. C. Filho, "Forward Dual-Active-Bridge solid-state transformer for a SiC-based cascaded multilevel converter cell in solar applications," *IEEE Trans. Ind. Appl.*, vol. 54, no. 6, pp. 6353–6363, Nov. 2018.
- [12] M. Rabiul Islam, A. M. Mahfuz-Ur-Rahman, K. M. Muttaqi, and D. Sutanto, "State-of-the-art of the medium-voltage power converter technologies for grid integration of solar photovoltaic power plants," *IEEE Trans. Energy Convers.*, vol. 34, no. 1, pp. 372–384, Mar. 2019.
- [13] P. Sochor and H. Akagi, "Theoretical comparison in energy-balancing capability between star- and delta-configured modular multilevel cascade inverters for utility-scale photovoltaic systems," *IEEE Trans. Power Electron.*, vol. 31, no. 3, pp. 1980–1992, Mar. 2016.
- [14] S. Kouro, M. Malinowski, K. Gopakumar, J. Pou, L. G. Franquelo, B. Wu, J. Rodriguez, M. A. Pérez, and J. I. Leon, "Recent advances and industrial applications of multilevel converters," *IEEE Trans. Ind. Electron.*, vol. 57, no. 8, pp. 2553–2580, Aug. 2010.
- [15] W. Song and A. Q. Huang, "Fault-tolerant design and control strategy for cascaded H-bridge multilevel converter-based STATCOM," *IEEE Trans. Ind. Electron.*, vol. 57, no. 8, pp. 2700–2708, Aug. 2010.
- [16] G. Fariivar, C. D. Townsend, B. Hredzak, J. Pou, and V. G. Agelidis, "Low-capacitance cascaded H-Bridge multilevel StatCom," *IEEE Trans. Power Electron.*, vol. 32, no. 3, pp. 1744–1754, Mar. 2017.
- [17] L. Wu and W. Mingli, "Single-phase cascaded H-bridge multi-level active power filter based on direct current control in AC electric railway application," *IET Power Electron.*, vol. 10, no. 6, pp. 637–645, May 2017.
- [18] H. Hasabelrasul, X. Yan, and A. S. Gadalla, "Power conditioning system control strategy for cascaded H-bridge converter battery energy storage system," *J. Eng.*, vol. 2019, no. 16, pp. 663–667, Mar. 2019.
- [19] Z. Yang, J. Sun, Y. Tang, M. Huang, and X. Zha, "An integrated dual voltage loop control for capacitance reduction in CHB-based regenerative motor drive systems," *IEEE Trans. Ind. Electron.*, vol. 66, no. 5, pp. 3369–3379, May 2019.
- [20] Z. Yang, J. Sun, X. Zha, and Y. Tang, "Power decoupling control for capacitance reduction in cascaded-H-bridge-converter-based regenerative motor drive systems," *IEEE Trans. Power Electron.*, vol. 34, no. 1, pp. 538–549, Jan. 2019.
- [21] E. Villanueva, P. Correa, J. Rodriguez, and M. Pacas, "Control of a single-phase cascaded H-Bridge multilevel inverter for grid-connected photovoltaic systems," *IEEE Trans. Ind. Electron.*, vol. 56, no. 11, pp. 4399–4406, Nov. 2009.
- [22] G. Fariivar, B. Hredzak, and V. G. Agelidis, "A DC-side sensorless cascaded H-bridge multilevel converter-based photovoltaic system," *IEEE Trans. Ind. Electron.*, vol. 63, no. 7, pp. 4233–4241, Jul. 2016.
- [23] A. Kumar and V. Verma, "Performance enhancement of single-phase grid-connected PV system under partial shading using cascaded multilevel converter," *IEEE Trans. Ind. Appl.*, vol. 54, no. 3, pp. 2665–2676, May 2018.



- [24] L. Liu, H. Li, Y. Xue, and W. Liu, "Decoupled active and reactive power control for large-scale grid-connected photovoltaic systems using cascaded modular multilevel converters," *IEEE Trans. Power Electron.*, vol. 30, no. 1, pp. 176–187, Jan. 2015.
- [25] Y. Shi, R. Li, Y. Xue, and H. Li, "High-Frequency-Link-Based grid-tied PV system with small DC-link capacitor and low-frequency ripple-free maximum power point tracking," *IEEE Trans. Power Electron.*, vol. 31, no. 1, pp. 328–339, Jan. 2016.
- [26] F. V. Amaral, T. M. Parreiras, G. C. Lobato, A. A. P. Machado, I. A. Pires, and B. de Jesus Cardoso Filho, "Operation of a grid-tied cascaded multilevel converter based on a forward solid-state transformer under unbalanced PV power generation," *IEEE Trans. Ind. Appl.*, vol. 54, no. 5, pp. 5493–5503, Sep. 2018.
- [27] Y. Yu, G. Konstantinou, B. Hredzak, and V. G. Agelidis, "Power balance of cascaded H-Bridge multilevel converters for large-scale photovoltaic integration," *IEEE Trans. Power Electron.*, vol. 31, no. 1, pp. 292–303, Jan. 2016.
- [28] Y. Yu, G. Konstantinou, B. Hredzak, and V. G. Agelidis, "Power balance optimization of cascaded H-Bridge multilevel converters for large-scale photovoltaic integration," *IEEE Trans. Power Electron.*, vol. 31, no. 2, pp. 1108–1120, Feb. 2016.
- [29] Y. Yu, G. Konstantinou, C. D. Townsend, R. P. Aguilera, and V. G. Agelidis, "Delta-connected cascaded H-Bridge multilevel converters for large-scale photovoltaic grid integration," *IEEE Trans. Ind. Electron.*, vol. 64, no. 11, pp. 8877–8886, Nov. 2017.
- [30] P. Sochor, H. Akagi, and N. M. L. Tan, "Low-voltage-ride-through control of a modular multilevel SDBC inverter for utility-scale photovoltaic systems," in *Proc. IEEE Energy Convers. Congr. Expo. (ECCE)*, Oct. 2017, pp. 4865–4872.
- [31] P. Sochor and H. Akagi, "Theoretical and experimental comparison between phase-shifted PWM and level-shifted PWM in a modular multilevel SDBC inverter for utility-scale photovoltaic applications," *IEEE Trans. Ind. Appl.*, vol. 53, no. 5, pp. 4695–4707, Sep. 2017.
- [32] M. R. Islam, Y. Guo, and J. Zhu, "A high-frequency link multilevel cascaded medium-voltage converter for direct grid integration of renewable energy systems," *IEEE Trans. Power Electron.*, vol. 29, no. 8, pp. 4167–4182, Aug. 2014.
- [33] M. R. Islam, A. M. Mahfuz-Ur-Rahman, M. M. Islam, Y. G. Guo, and J. G. Zhu, "Modular medium-voltage grid-connected converter with improved switching techniques for solar photovoltaic systems," *IEEE Trans. Ind. Electron.*, vol. 64, no. 11, pp. 8887–8896, Nov. 2017.
- [34] S. Kouro, C. Fuentes, M. Perez, and J. Rodriguez, "Single DC-link cascaded H-bridge multilevel multistring photovoltaic energy conversion system with inherent balanced operation," in *Proc. 38th Annu. Conf. IEEE Ind. Electron. Soc.*, Oct. 2012, pp. 4998–5005.
- [35] C. D. Fuentes, C. A. Rojas, H. Renaudineau, S. Kouro, M. A. Perez, and T. Meynard, "Experimental validation of a single DC bus cascaded H-bridge multilevel inverter for multistring photovoltaic systems," *IEEE Trans. Ind. Electron.*, vol. 64, no. 2, pp. 930–934, Feb. 2017.
- [36] M. R. Islam, Y. Guo, and J. Zhu, "A medium-frequency transformer with multiple secondary windings for grid connection through H-bridge voltage source converters," in *Proc. 15th Int. Conf. Elect. Mach. Syst. (ICEMS)*, 2012, pp. 1–6.
- [37] D. Azuma and R. Hasegawa, "Core loss in Toroidal cores based on Fe-based amorphous Metglas 2605HB1 alloy," *IEEE Trans. Magn.*, vol. 47, no. 10, pp. 3460–3462, Oct. 2011.
- [38] T. Fan, Q. Li, and X. Wen, "Development of a high power density motor made of amorphous alloy cores," *IEEE Trans. Ind. Electron.*, vol. 61, no. 9, pp. 4510–4518, Sep. 2014.
- [39] M. Ohta and R. Hasegawa, "Soft magnetic properties of magnetic cores assembled with a high  $B_s$  Fe-based nanocrystalline alloy," *IEEE Trans. Magn.*, vol. 53, no. 2, pp. 1–5, Feb. 2017.
- [40] A. Lesnicar and R. Marquardt, "An innovative modular multilevel converter topology suitable for a wide power range," in *Proc. IEEE Bologna Power Tech Conf.*, vol. 3, Jun. 2003, p. 6.
- [41] Y. Ma, G. Zou, S. Song, J. Guo, and Z. Gao, "Novel fault current-limiting scheme for MMC-based flexible HVDC system," *J. Eng.*, vol. 2019, no. 16, pp. 2233–2238, Mar. 2019.
- [42] M. Fawzi, F. Briz, and A. E. Kalas, "DC short circuit ride-through strategy for a full-bridge MMC HVDC transmission system," in *Proc. 19th Eur. Conf. Power Electron. Appl. (EPE ECCE Eur.)*, Sep. 2017, p. 10.
- [43] P. Cai, W. Xiang, and J. Wen, "Modelling and control of a back-to-back MMC–HVDC system using ADPSS," *J. Eng.*, vol. 2019, no. 16, pp. 1252–1256, Mar. 2019.
- [44] B. Li, S. Zhou, D. Xu, S. J. Finney, and B. W. Williams, "A hybrid modular multilevel converter for medium-voltage variable-speed motor drives," *IEEE Trans. Power Electron.*, vol. 32, no. 6, pp. 4619–4630, Jun. 2017.
- [45] M. S. Diab, A. M. Massoud, S. Ahmed, and B. W. Williams, "A modular multilevel converter with ripple-power decoupling channels for three-phase MV adjustable-speed drives," *IEEE Trans. Power Electron.*, vol. 34, no. 5, pp. 4048–4063, May 2019.
- [46] M. S. Diab, A. M. Massoud, S. Ahmed, and B. W. Williams, "A dual modular multilevel converter with high-frequency magnetic links between submodules for MV open-end stator winding machine drives," *IEEE Trans. Power Electron.*, vol. 33, no. 6, pp. 5142–5159, Jun. 2018.
- [47] V. Spudic and T. Geyer, "Model predictive control based on optimized pulse patterns for modular multilevel converter STATCOM," *IEEE Trans. Ind. Appl.*, vol. 55, no. 6, pp. 6137–6149, Nov. 2019.
- [48] H. M. P., and M. T. Bina, "A transformerless medium-voltage STATCOM topology based on extended modular multilevel converters," *IEEE Trans. Power Electron.*, vol. 26, no. 5, pp. 1534–1545, May 2011.
- [49] H. Akagi, "Classification, terminology, and application of the modular multilevel cascade converter (MMCC)," *IEEE Trans. Power Electron.*, vol. 26, no. 11, pp. 3119–3130, Nov. 2011.
- [50] J. Mei, B. Xiao, K. Shen, L. M. Tolbert, and J. Y. Zheng, "Modular multilevel inverter with new modulation method and its application to photovoltaic grid-connected generator," *IEEE Trans. Power Electron.*, vol. 28, no. 11, pp. 5063–5073, Nov. 2013.
- [51] H. Nademi, A. Das, R. Burgos, and L. E. Norum, "A new circuit performance of modular multilevel inverter suitable for photovoltaic conversion plants," *IEEE J. Emerg. Sel. Topics Power Electron.*, vol. 4, no. 2, pp. 393–404, Jun. 2016.
- [52] A. Rashwan, "A new topology for the large-scale photovoltaic systems grid connection based on modular multilevel converter," in *Proc. 20th Int. Middle East Power Syst. Conf. (MEPCON)*, Dec. 2018, pp. 286–291.
- [53] S. Rivera, B. Wu, R. Lizana, S. Kouro, M. Perez, and J. Rodriguez, "Modular multilevel converter for large-scale multistring photovoltaic energy conversion system," in *Proc. IEEE Energy Convers. Congr. Expo.*, Sep. 2013, pp. 1947–1952.
- [54] F. Rong, X. Gong, and S. Huang, "A novel grid-connected PV system based on MMC to get the maximum power under partial shading conditions," *IEEE Trans. Power Electron.*, vol. 32, no. 6, pp. 4320–4333, Jun. 2017.
- [55] H. Bayat and A. Yazdani, "A power mismatch elimination strategy for an MMC-based photovoltaic system," *IEEE Trans. Energy Convers.*, vol. 33, no. 3, pp. 1519–1528, Sep. 2018.
- [56] M. A. Perez, S. Bernet, J. Rodriguez, S. Kouro, and R. Lizana, "Circuit topologies, modeling, control schemes, and applications of modular multilevel converters," *IEEE Trans. Power Electron.*, vol. 30, no. 1, pp. 4–17, Jan. 2015.
- [57] S. Debnath, J. Qin, B. Bahrani, M. Saefidifard, and P. Barbosa, "Operation, control, and applications of the modular multilevel converter: A review," *IEEE Trans. Power Electron.*, vol. 30, no. 1, pp. 37–53, Jan. 2015.
- [58] X. She, A. Q. Huang, and R. Burgos, "Review of solid-state transformer technologies and their application in power distribution systems," *IEEE J. Emerg. Sel. Topics Power Electron.*, vol. 1, no. 3, pp. 186–198, Sep. 2013.
- [59] F. Zhang, Y. Xie, Y. Hu, G. Chen, and X. Wang, "A hybrid boost-flyback/flyback microinverter for photovoltaic applications," *IEEE Trans. Ind. Electron.*, vol. 67, no. 1, pp. 308–318, Jan. 2020.
- [60] B. Tamyurek and B. Kirimer, "An interleaved high-power flyback inverter for photovoltaic applications," *IEEE Trans. Power Electron.*, vol. 30, no. 6, pp. 3228–3241, Jun. 2015.
- [61] M. A. Chewale, V. B. Savakhande, R. A. Wanjari, and P. R. Sonawane, "Grid-tied PV inverter based on interleaved flyback converter," in *Proc. Int. Conf. Control, Power, Commun. Comput. Technol. (ICCCCT)*, Mar. 2018, pp. 421–426.
- [62] P. He, A. Mallik, A. Sankar, and A. Khaligh, "Design of a 1-MHz high-efficiency high-power-density bidirectional GaN-based CLLC converter for electric vehicles," *IEEE Trans. Veh. Technol.*, vol. 68, no. 1, pp. 213–223, Jan. 2019.
- [63] A. A. R. F. E. Cardoso, N. C. Foureaux, J. A. S. Brito, and B. J. Cardoso F., "SiC based cascaded multilevel converter for solar applications: Down-scaled prototype development," in *Proc. IEEE 13th Brazilian Power Electron. Conf. 1st Southern Power Electron. Conf. (COBEP/SPEC)*, Nov. 2015, pp. 1–6.



- [64] EPCOS AG, Munich, Germany. (2002). *Aluminum Electrolytic Capacitors-General Technical Information*. [Online]. Available: [https://www.mikrocontroller.net/attachment/138352/Aluminum\\_Electrolytic\\_Capacitors\\_EPCOS.pdf](https://www.mikrocontroller.net/attachment/138352/Aluminum_Electrolytic_Capacitors_EPCOS.pdf)
- [65] R. Mirzahassemi and F. Tahami, "A lifetime improved single phase grid connected photovoltaic inverter," in *Proc. 3rd Power Electron. Drive Syst. Technol. (PEDSTC)*, Feb. 2012, pp. 234–238.
- [66] Y. Shi, L. Liu, H. Li, and Y. Xue, "A single-phase grid-connected PV converter with minimal DC-link capacitor and low-frequency ripple-free maximum power point tracking," in *Proc. IEEE Energy Convers. Congr. Expo.*, Sep. 2013, pp. 2385–2390.
- [67] Y. Shi, R. Li, Y. Xue, and H. Li, "Optimized operation of current-fed dual active bridge DC–DC converter for PV applications," *IEEE Trans. Ind. Electron.*, vol. 62, no. 11, pp. 6986–6995, Nov. 2015.
- [68] Y. Ting, S. de Haan, and B. Ferreira, "Modular single-active bridge DC-DC converters: Efficiency optimization over a wide load range," *IEEE Ind. Appl. Mag.*, vol. 22, no. 5, pp. 43–52, Sep. 2016.
- [69] S. Zengin and M. Boztepe, "Modified dual active bridge photovoltaic inverter for solid state transformer applications," in *Proc. Int. Symp. Fundamentals Electr. Eng. (ISFEE)*, Nov. 2014, pp. 1–4.
- [70] S. Kulasekaran and R. Ayyanar, "Analysis, design, and experimental results of the semidual-active-bridge converter," *IEEE Trans. Power Electron.*, vol. 29, no. 10, pp. 5136–5147, Oct. 2014.
- [71] H. Akagi, H. Fujita, S. Yonetani, and Y. Kondo, "A 6.6-kV transformerless STATCOM based on a five-level diode-clamped PWM converter: System design and experimentation of a 200-V 10-kVA laboratory model," *IEEE Trans. Ind. Appl.*, vol. 44, no. 2, pp. 672–680, Mar. 2008.
- [72] F. Filho, Y. Cao, and L. M. Tolbert, "11-level cascaded H-bridge grid-tied inverter interface with solar panels," in *Proc. 25th Annu. IEEE Appl. Power Electron. Conf. Expo. (APEC)*, Feb. 2010, pp. 968–972.
- [73] J. D. Stringfellow, T. J. Summers, and R. E. Betz, "Control of the modular multilevel converter as a photovoltaic interface under unbalanced irradiance conditions with MPPT of each PV array," in *Proc. IEEE 2nd Annu. Southern Power Electron. Conf. (SPEC)*, Dec. 2016, pp. 1–6.
- [74] B. Xiao, K. Shen, J. Mei, F. Filho, and L. M. Tolbert, "Control of cascaded H-bridge multilevel inverter with individual MPPT for grid-connected photovoltaic generators," in *Proc. IEEE Energy Convers. Congr. Expo. (ECCE)*, Sep. 2012, pp. 3715–3721.
- [75] M. S. Shadlu, "A comparative study between two MPPT algorithms for photovoltaic energy conversion system based on modular multilevel converter," in *Proc. Electr. Eng. (ICEE), Iranian Conf.*, May 2018, pp. 1154–1159.
- [76] H. Nademi, A. Elahidoost, and L. E. Norum, "Comparative analysis of different MPPT schemes for photovoltaic integration of modular multilevel converter," in *Proc. IEEE 17th Workshop Control Modeling Power Electron. (COMPEL)*, Jun. 2016, pp. 1–5.
- [77] T. Esram and P. L. Chapman, "Comparison of photovoltaic array maximum power point tracking techniques," *IEEE Trans. Energy Convers.*, vol. 22, no. 2, pp. 439–449, Jun. 2007.
- [78] C. Boonmee and Y. Kumsuwan, "Control of single-phase cascaded H-bridge multilevel inverter with modified MPPT for grid-connected photovoltaic systems," in *Proc. 39th Annu. Conf. IEEE Ind. Electron. Soc. (IECON)*, Nov. 2013, pp. 566–571.
- [79] G. Farivar, V. G. Agelidis, and B. Hredzak, "A simple perturb and observe MPPT scheme for cascaded H-Bridge based photovoltaic system," in *Proc. Australas. Universities Power Eng. Conf. (AUPEC)*, Sep. 2013, pp. 1–5.
- [80] H. Nademi, L. E. Norum, and S. Wersland, "An accurate MPPT scheme for photovoltaic modular-based conversion units: A robust sensorless predictive approach," in *Proc. IEEE 18th Workshop Control Modeling Power Electron. (COMPEL)*, Jul. 2017, pp. 1–6.
- [81] Q. Huang, M. Wang, W. Yu, and A. Q. Huang, "Power-weighting-based multiple input and multiple output control strategy for single-phase PV cascaded H-bridge multilevel grid-connected inverter," in *Proc. IEEE Appl. Power Electron. Conf. Expo. (APEC)*, Mar. 2015, pp. 2148–2153.
- [82] J. Chavarria, D. Biel, F. Guinjoan, C. Meza, and J. J. Negroni, "Energy-balance control of PV cascaded multilevel grid-connected inverters under level-shifted and phase-shifted PWMs," *IEEE Trans. Ind. Electron.*, vol. 60, no. 1, pp. 98–111, Jan. 2013.
- [83] C. Wang, K. Zhang, J. Xiong, Y. Xue, and W. Liu, "An efficient modulation strategy for cascaded photovoltaic systems suffering from module mismatch," *IEEE J. Emerg. Sel. Topics Power Electron.*, vol. 6, no. 2, pp. 941–954, Jun. 2018.
- [84] B. Sharma and J. Nakka, "Single-phase cascaded multilevel inverter topology addressed with the problem of unequal photovoltaic power distribution in isolated DC links," *IET Power Electron.*, vol. 12, no. 2, pp. 284–294, Feb. 2019.
- [85] M. Aleenejad, S. Farhangi, and H. Iman-Eini, "Modified space vector modulation for fault-tolerant operation of multilevel cascaded H-bridge inverters," *IET Power Electron.*, vol. 6, no. 4, pp. 742–751, Apr. 2013.
- [86] M. Moosavi, G. Farivar, H. Iman-Eini, and S. M. Shekarabi, "A voltage balancing strategy with extended operating region for cascaded H-bridge converters," *IEEE Trans. Power Electron.*, vol. 29, no. 9, pp. 5044–5053, Sep. 2014.
- [87] H. Zhao, T. Jin, S. Wang, and L. Sun, "A real-time selective harmonic elimination based on a transient-free inner closed-loop control for cascaded multilevel inverters," *IEEE Trans. Power Electron.*, vol. 31, no. 2, pp. 1000–1014, Feb. 2016.
- [88] K. Wang, R. Zhu, C. Wei, F. Liu, X. Wu, and M. Liserre, "Cascaded multilevel converter topology for large-scale photovoltaic system with balanced operation," *IEEE Trans. Ind. Electron.*, vol. 66, no. 10, pp. 7694–7705, Oct. 2019.
- [89] L. Xiong, Y. Gui, H. Liu, W. Yang, and J. Gong, "A hybrid CHB multilevel inverter with supercapacitor energy storage for grid-connected photovoltaic systems," in *Proc. IEEE Appl. Power Electron. Conf. Expo. (APEC)*, Mar. 2018, pp. 3195–3199.
- [90] C. D. Townsend, T. J. Summers, and R. E. Betz, "Control and modulation scheme for a cascaded H-bridge multi-level converter in large scale photovoltaic systems," in *Proc. IEEE Energy Convers. Congr. Expo. (ECCE)*, Sep. 2012, pp. 3707–3714.
- [91] S. Rivera, B. Wu, S. Kouro, H. Wang, and D. Zhang, "Cascaded H-bridge multilevel converter topology and three-phase balance control for large scale photovoltaic systems," in *Proc. 3rd IEEE Int. Symp. Power Electron. Distrib. Gener. Syst. (PEDG)*, Jun. 2012, pp. 690–697.
- [92] B. Xiao, L. Hang, J. Mei, C. Riley, L. M. Tolbert, and B. Ozpineci, "Modular cascaded H-bridge multilevel PV inverter with distributed MPPT for grid-connected applications," *IEEE Trans. Ind. Appl.*, vol. 51, no. 2, pp. 1722–1731, Mar. 2015.
- [93] Y. Yu, G. Konstantinou, C. D. Townsend, and V. G. Agelidis, "Comparison of zero-sequence injection methods in cascaded H-bridge multilevel converters for large-scale photovoltaic integration," *IET Renew. Power Gener.*, vol. 11, no. 5, pp. 603–613, Apr. 2017.
- [94] S. Kouro, B. Wu, A. Moya, E. Villanueva, P. Correa, and J. Rodriguez, "Control of a cascaded H-bridge multilevel converter for grid connection of photovoltaic systems," in *Proc. 35th Annu. Conf. IEEE Ind. Electron.*, Nov. 2009, pp. 3976–3982.
- [95] Y. Yu, G. Konstantinou, B. Hredzak, and V. G. Agelidis, "On extending the energy balancing limit of multilevel cascaded H-bridge converters for large-scale photovoltaic farms," in *Proc. Australas. Universities Power Eng. Conf. (AUPEC)*, Sep. 2013, pp. 1–6.
- [96] Y. Yu, G. Konstantinou, B. Hredzak, and V. G. Agelidis, "Optimal zero sequence injection in multilevel cascaded H-bridge converter under unbalanced photovoltaic power generation," in *Proc. Int. Power Electron. Conf. (IPEC-Hiroshima-ECCE ASIA)*, May 2014, pp. 1458–1465.
- [97] S. A. Azmi, G. P. Adam, K. H. Ahmed, S. J. Finney, and B. W. Williams, "Grid interfacing of multimegawatt photovoltaic inverters," *IEEE Trans. Power Electron.*, vol. 28, no. 6, pp. 2770–2784, Jun. 2013.
- [98] B. K. Poolla, D. Gros, and F. Dorfler, "Placement and implementation of grid-forming and grid-following virtual inertia and fast frequency response," *IEEE Trans. Power Syst.*, vol. 34, no. 4, pp. 3035–3046, Jul. 2019.
- [99] K. Sun, L. Zhang, Y. Xing, and J. M. Guerrero, "A distributed control strategy based on DC bus signaling for modular photovoltaic generation systems with battery energy storage," *IEEE Trans. Power Electron.*, vol. 26, no. 10, pp. 3032–3045, Oct. 2011.
- [100] L. Zhang, Z. Zhang, J. Qin, D. Shi, and Z. Wang, "Design and performance evaluation of the modular multilevel converter (MMC)-based grid-tied PV-battery conversion system," in *Proc. IEEE Energy Convers. Congr. Expo. (ECCE)*, Sep. 2018, pp. 2649–2654.
- [101] T. Soong and P. W. Lehn, "Internal power flow of a modular multilevel converter with distributed energy resources," *IEEE J. Emerg. Sel. Topics Power Electron.*, vol. 2, no. 4, pp. 1127–1138, Dec. 2014.



**AHMED ELSANABARY** received the B.Eng. (Hons.) and Master of Science degrees in electrical engineering from Port Said University, Port Said, Egypt, in 2010 and 2016, respectively. He is currently pursuing the Ph.D. degree with the Department of Electrical Engineering, University of Malaya, Kuala Lumpur, Malaysia. From 2011 to 2018, he was a Demonstrator and an Assistant Lecturer with the Department of Electrical Power and Machines, Faculty of Engineering, Port Said

University. He is also associated with the Power Electronics and Renewable Energy Research Laboratory (PEARL) as a Graduate Research Assistant (GRA) since 2018. His research interests include control and modulation of multilevel converters, and their applications such as renewable energy systems, and electric drives.



**GEORGIOS KONSTANTINOU** (Senior Member, IEEE) received the B.Eng. degree in electrical and computer engineering from the Aristotle University of Thessaloniki, Thessaloniki, Greece, in 2007, and the Ph.D. degree in electrical engineering from the University of New South Wales (UNSW) Sydney, Sydney, NSW, Australia, in 2012. From 2013 to 2016, he was a Senior Research Associate with UNSW Sydney, where he was a part of the Australian Energy Research

Institute. Since 2017, he has been with the School of Electrical Engineering and Telecommunications, UNSW Sydney, where he is currently a Senior Lecturer. His main research interests include multilevel converters, power electronics in HVDC, renewable energy, and energy storage applications. He is an Associate Editor of IEEE TRANSACTIONS ON POWER ELECTRONICS, IEEE TRANSACTIONS ON INDUSTRIAL ELECTRONICS, and *IET Power Electronics*.



**SAAD MEKHILEF** (Senior Member, IEEE) received the B.Eng. degree in electrical engineering from the University of Setif, Setif, Algeria, in 1995, and the master's degree in engineering science and the Ph.D. degree in electrical engineering from the University of Malaya, Kuala Lumpur, Malaysia, in 1998 and 2003, respectively. He is currently a Professor and the Director of the Power Electronics and Renewable Energy Research Laboratory, Department of Electrical Engineering,

University of Malaya. He is also the Dean of the Faculty of Engineering, University of Malaya. He is also a Distinguished Adjunct Professor with the Faculty of Science, Engineering and Technology, School of Software and Electrical Engineering, Swinburne University of Technology, VIC, Australia. He has authored or coauthored more than 400 publications in international journals and conference proceedings. His current research interests include power converter topologies, control of power converters, renewable energy, and energy efficiency.



**CHRISTOPHER DAVID TOWNSEND** (Member, IEEE) received the B.E. and Ph.D. degrees in electrical engineering from The University of Newcastle, Australia, in 2009 and 2013, respectively. Subsequently, he spent three years working at ABB Corporate Research, Sweden, working on next-generation high-power converter technologies. Since then, he has held various postdoctoral research positions, including at the University of New South Wales, Australia, The University of

Newcastle, and Nanyang Technological University, Singapore. In 2019, he joined the Department of Electrical, Electronic and Computer Engineering, The University of Western Australia, as a Senior Lecturer. He has authored more than 60 published technical papers and has been involved in several industrial projects and educational programs in the field of power electronics. His research interests include topologies and modulation strategies for multilevel converters applied in power systems, renewable energy integration, and electric vehicle applications. He is a member of the IEEE Power Electronics and Industrial Electronics societies.



**MEHDI SEYEDMAHMOUDIAN** (Member, IEEE) received the B.Sc., M.Eng., and Ph.D. degrees in electrical engineering. He was a Lecturer and a Course Coordinator with the School of Engineering, Deakin University, Australia. He is currently the Research Director of the Department of Telecommunications, Electrical, Robotics and Biomedical Engineering and the Major Discipline Coordinator (electrical engineering) of the School of Software and Electrical Engineering,

Swinburne University of Technology, Australia. His research interests include renewable energy systems, smart grids and microgrids systems, and the application of emerging technologies in green renewable energy development.



**ALEX STOJCEVSKI** (Member, IEEE) received the bachelor's degree in electrical engineering, the master's (by research) degree in electrical and electronics engineering, the master's degree in education, and the master's degree in project-based learning (PBL) in engineering and science from Aalborg University, Denmark, and the Ph.D. degree. He is currently the Dean of the School of Software and Electrical Engineering, Swinburne University of Technology, Melbourne, Australia.

He has held numerous senior positions in several universities across different countries. He has published more than 250 book chapters, journals, and conference papers. He has given a number of internationally invited speaker presentations. His research interests include renewable energy and micro grid design.

...