

Received October 24, 2020, accepted November 8, 2020, date of publication November 24, 2020, date of current version December 30, 2020.

Digital Object Identifier 10.1109/ACCESS.2020.3040184

A Survey of Brake-by-Wire System for Intelligent Connected Electric Vehicles

BUMIN MENG¹, (Member, IEEE), FEIFAN YANG¹, JINGANG LIU¹, AND YAONAN WANG²

¹The School of Automation and Electronic Information, Xiangtan University, Xiangtan 411105, China

²The College of Electrical and Information engineering, Hunan University, Changsha 410082, China

Corresponding author: Bumin Meng (mengbm@163.com)

This work was supported in part by the Hunan Education Department under Project 18C0088, in part by the Natural Science Foundation of China under Grant 62003288 and Grant 52075465, in part by the Excellent Youth Foundation of Hunan Scientific Committee under Grant 2019JJ20015, and in part by the Natural Science Foundation of Hunan Province of China under Grant 2020JJ5553.

ABSTRACT Intelligent connected electric vehicles (EVs) are widely considered as a trend in the global automotive industry to make transportation safer, cleaner and more comfortable. As an important component of intelligent connected EVs, the brake-by-wire (BBW) system is the key to determining the performance of the vehicle and the efficiency of braking energy recovery. BBW systems are showing great promise in the area of vehicle braking due to the increasing requirements on safety and energy efficiency of vehicles. In recent years, BBW systems have undergone great changes in terms of structure and control methods, not only increasing safety and energy recovery efficiency, but also integrating more functions. Although important advancements have been achieved in this field, these works have not been fully summarised. This paper surveys and summarizes the research in literature to bring topical information to the field of intelligent transportation systems. The objective of this study is to present an overview of both the development trend and key technologies of the BBW system for intelligent connected EVs. Firstly, the development, structure and core components of BBW system are described. Secondly, the control method and control strategy of BBW system are analyzed. As much as the system shows great promise, the problems existing on its current technology should be addressed as well. Finally, some important countermeasures are proposed to solve the existing technical problems of the BBW system.

INDEX TERMS Intelligent connected vehicle, electric vehicle, brake-by-wire system, braking energy recovery.

I. INTRODUCTION

Electrification and intelligent network connection have become the strategic direction of global automotive industry development. The intelligent connected EVs can connect the vehicles with the information about people, vehicles, roadside and clouds. The combination of intelligent method and drive-by-wire technology can make the vehicle more safe, comfortable, energy-saving and efficient [1]. The International Energy Agency (IEA) predicts that by 2030, more than 10 million intelligent connected EVs will be sold worldwide and the market size will exceed one trillion dollars [2].

The BBW system is the key to controlling the energy efficiency level of intelligent connected EVs, and it is also the top priority to determine the safety, comfort and service life of the vehicles [3]. BBW system has outstanding

advantages, such as fast response, accurate control and high energy efficiency. The obvious difference between BBW and conventional braking systems is that it replaces some of the mechanical and hydraulic components with electronic control elements, using cables and wires to transmit energy and signals [4]. In order to satisfy the increasing demand for braking performance, the development of BBW system has undergone significant improvements. Apart from optimization of the structure, advanced algorithms have been applied to the control of BBW, especially the application of complex algorithms, which greatly improves the performance of BBW systems. In recent years, machine learning is increasingly being applied to the control of BBW systems with the availability of large amounts of training data. The ability of machine learning to learn from data and self-optimize behavior makes machine learning well suited to control problems in complex and dynamic environments. Hence, machine learning is applied to cooperative control

The associate editor coordinating the review of this manuscript and approving it for publication was Xiaosong Hu¹.

based on driving style, braking prediction, braking force optimization, etc., which significantly improves braking stability, energy economy and comfort. The prediction of braking intent and braking strength leads to a significant increase in the safety and energy recovery ratio of intelligent connected EVs during braking. In addition, BBW system is easily integrated with active safety functions and easily matched with regenerative braking systems in intelligent connected EVs. The safety performance and energy utilization efficiency of braking system has been greatly improved. Apart from the basic pedal brake function, the braking system of intelligent connected EVs also needs to achieve active brake-by-wire, pedal feeling adjustment, high dynamic real-time pressure building, man-machine driving decoupling control and other functions. However, the integration of additional functions leads to a more complex structure and control of BBW system and more difficult maintenance. The braking control problem of intelligent connected EVs presents the following new characteristics: (1) Complexity of electromechanical and hydraulic cooperative control. (2) The diversification of efficiency influencing factors. (3) Information system and power components multi-field coupling. Based on the above new characteristics of intelligent connected EVs braking system, the thorough study of the coordinated control theory of electromechanical and hydraulic efficient matching during the braking process will be beneficial to give full play to the advantages of intelligent and energy saving of the connected EV, and effectively guarantee the safety, efficiency and life of the system operation.

This survey summarizes the relevant work in this field with the aim of bringing topical information to the field of intelligent transportation systems. In this paper, the development trend and key technologies of the BBW system for the application of intelligent connected EVs are analyzed and discussed. The paper is organized as follows: Section II summarizes the type and development trend of BBW system. The structure of the BBW system for intelligent connected EVs is introduced in section III. Section IV describes the core components and key technologies of the BBW system. Section V discusses the control methods of BBW system: dynamics and kinematics control. The control strategy of the BBW system is discussed in section VI. Finally, Section VII concludes the existing problems and important countermeasures.

II. TYPE AND DEVELOPMENT TREND OF BRAKE-BY-WIRE SYSTEM

A. TYPE OF BRAKE-BY-WIRE SYSTEM

An increasing number of BBW system types are proposed with continuous research in the field of braking. There have been many forms of BBW system [5], [6]. Meanwhile, these braking systems optimize the structure and integrate other functions, braking performance has been greatly improved, and more energy efficiency. According to the transmission mode of braking energy, the BBW system can be divided into mechanical type, hydraulic type, pneumatic type, electromagnetic type and other types. The BBW system that

adopts two or more modes of energy transmission is called hybrid braking system (HBS). This paper mainly introduces mechanical, hydraulic, electromagnetic and hybrid braking systems as follows:

(1) The mechanical braking system transmits braking force through the mechanical connection between the actuator and the brake wheel to realize the deceleration or braking of the automobile. Such as electro-mechanical braking (EMB) system, is also the most common braking system.

(2) The hydraulic BBW system is developed from the traditional hydraulic braking system and consists of the traditional hydraulic system and electronic control unit. The braking force of system is established through the brake fluid pipe between the actuator and the brake wheel. In addition to the traditional electronic hydraulic braking (EHB) system, there are distributed electronic hydraulic braking (DEHB) system, integrated electronic hydraulic (IEHB) braking system and so on.

(3) Mechanical and hydraulic braking systems are the most common braking systems in automobile engineering. With the development of braking systems, the electromagnetic braking system is gradually applied in automotive braking system.

(4) In order to integrate the advantages of the braking system and further improve the performance of the braking system, some hybrid braking systems have been proposed. such as electro-magnetic hydraulic hybrid braking, electromechanical hydraulic braking system etc.

B. DEVELOPMENT TREND OF BRAKE-BY-WIRE SYSTEM

In recent years, motor servo power system combined with electronic brake booster and hydraulic regulating unit has been widely used in current intelligent connected EVs. With the continuous development and application of the research, such a system is gradually transforming to integration. Bethel launched WCBS in July 2019, which not only integrates vacuum booster, electronic vacuum pump, master cylinder and electronic stability control (ESC) functions, but also better meets the new braking system requirements of new energy vehicles and intelligent vehicle driving.

Through early patent and technology research, Toyota ADVIC, Hitachi, Continental, Bosch, ZF-TRW and other companies began to make layout in BBW technology. With the promotion of level 2 intelligent connected EVs, the application of BBW system has experienced the technical solutions of 1 Box, 2 Box and 3 Box based on the number of electronic units. As the early 3 Box scheme only used electronic vacuum pump, pedal stroke sensor and air pressure sensor, combined with the traditional electronic stability program (ESP) and anti-lock braking system (ABS), the friction braking force has poor adjustability, low energy recovery and poor braking comfort, which is gradually being replaced.

Fig 1 provides an overview of typical solution and future trend of BBW systems. It can be seen that the typical solutions introduced by Hitachi, Continental, Bosch and others in the last decade. Presently, vacuum boosters hold the major

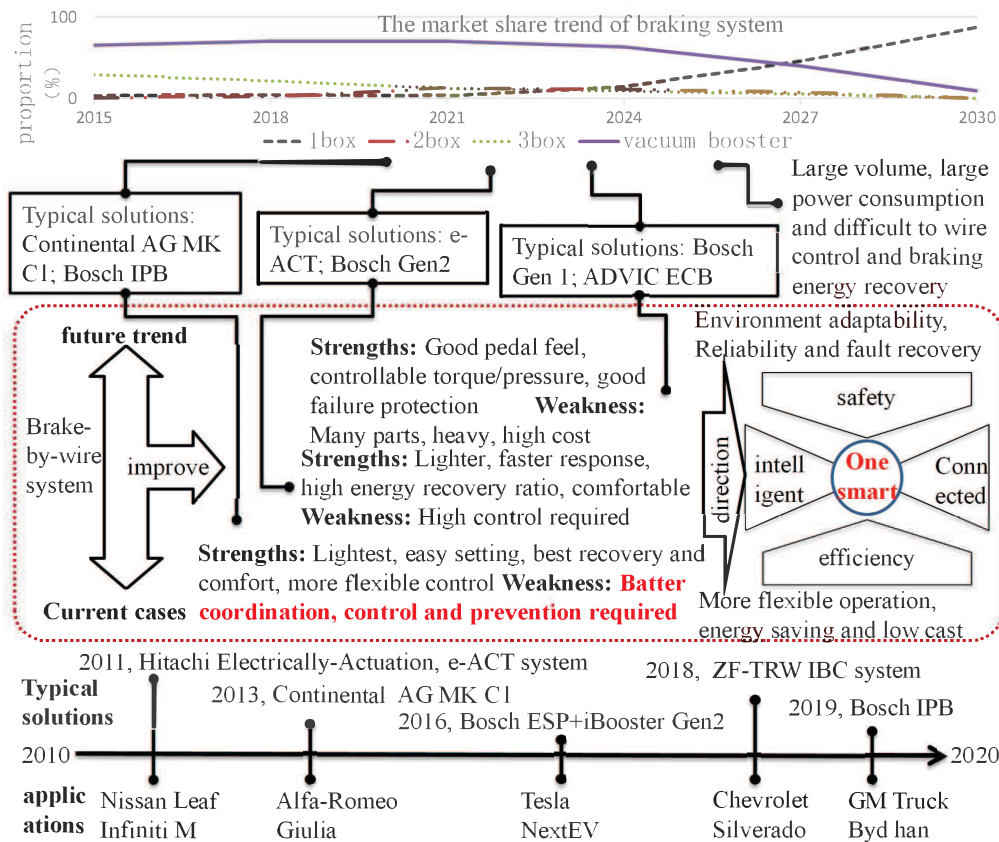

FIGURE 1. Development history and trend of BBW system.

market share of braking systems. However, vacuum booster cannot provide auxiliary force for EVs, and vacuum booster has the defects of large volume, high power consumption, difficult wire control and recovery of braking energy. Based on the 1 box has obvious advantages such as easy setting, best recovery and comfort and more flexible control, it will gradually replace vacuum booster and occupy the major share of the braking system market in the next ten years. Although the 2 box and 3 box have outstanding advantages, their braking market share will not change significantly in the next ten years due to their own weaknesses and immature technology. Current BBW systems face several problems in terms of structure, performance and energy efficiency, which are the focus of future research [7], [8].

III. STRUCTURE OF BRAKE-BY-WIRE SYSTEM FOR INTELLIGENT CONNECTED EVs

Fig 2 shows the structure of BBW System for intelligent connected EVs. This system consists of battery management system (BMS), BBW controller, motor controller, networking and intelligent systems, vehicle control unit, brake pedal, battery pack, drive motor and power transmission system.

In this system, BMS is a control system that protects the safety of the power battery, and monitors the battery status constantly to ensure the safety of intelligent connected EVs. The motor controller controls the starting operation, forward and reverse, climbing and other driving states of

the EV according to commands such as gear, throttle and brake, or helps the EV to brake when braking, and stores part of the braking energy into the power battery. The BBW controller components include master cylinder, servo motor, booster unit and hydraulic distribution unit. During braking, the displacement of the brake pedal and the servomotor increase the oil pressure in the master cylinder, which distributes the appropriate braking force to the wheels via the hydraulic distribution unit. A portion of the braking force is used for friction braking to ensure braking safety, while the other portion is used for regenerative braking to recover braking energy. In recovering the braking energy, the motor as a generator recovers part of the braking energy into the power battery.

IV. CORE COMPONENTS AND KEY TECHNOLOGIES OF BRAKE-BY-WIRE SYSTEM

In order to meet the increasing demands on the performance of the BBW system, the components of the BBW system are continuously optimized and the control technology is continuously improved. In terms of component control, current research is mainly focused on mechanical (power-assisted machinery, brake pads), electrical (power-assisted motor, drive motor, battery) and hydraulic (brake master cylinder, hydraulic valve). As shown in Fig 3. These studies address issues such as brake friction, precision control, ABS and dynamic response. In the braking process,

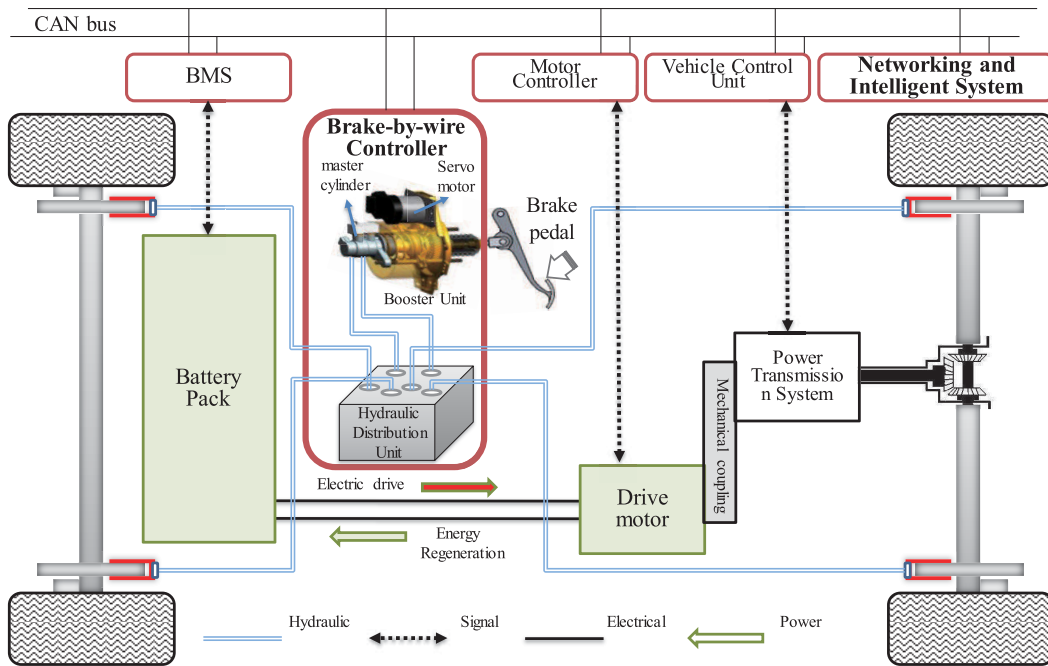

FIGURE 2. The structure of BBW System for intelligent connected EVs.

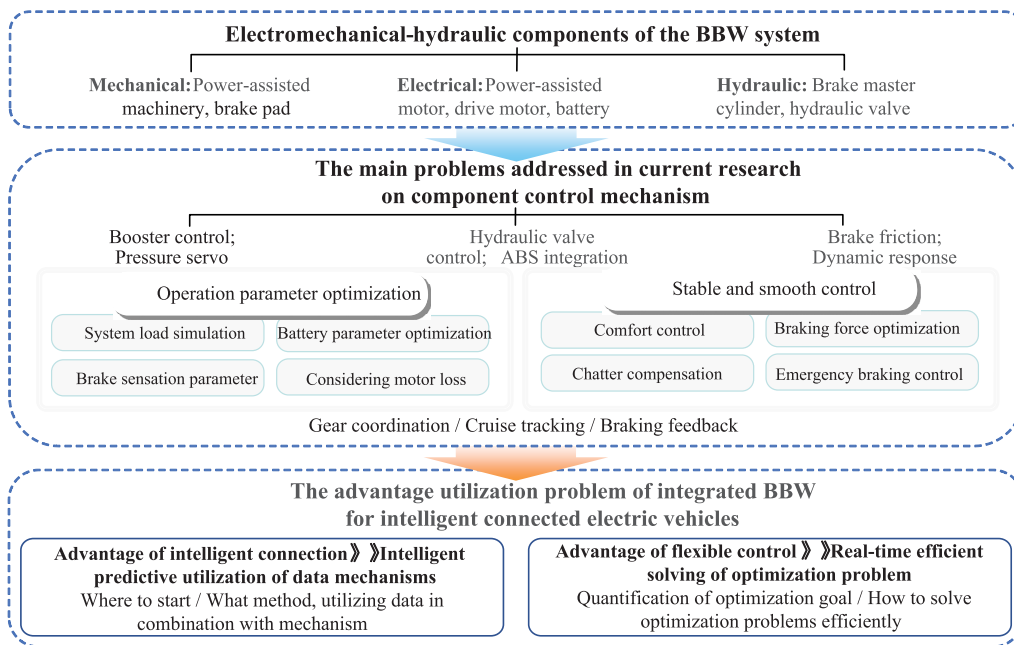

FIGURE 3. Current research methods of control mechanism of BBW system components.

the influence of friction on the performance of system can not be ignored. Power assist system converts the motor force into the thrust assist braking of the main cylinder push rod by means of the deceleration and torque increasing mechanism and the motion transferring mechanism. The friction generated during the motion of the mechanism combined with the normal force to affect the feedback control. Moreover, friction causes the chattering phenomenon in the process of mechanism control. In order to eliminate the influence of

friction in braking system control. In [9], a LuGre friction model is established to represent the friction characteristics of the braking system and identify the parameters of the friction model. Precise linear braking torque control is also required in vehicle dynamics control. Therefore, precise and fast control of hydraulic valves is required for precise linear brake torque control. In [10], [11], a hydraulic valve control based on sliding mode control and sensorless electromagnetic position estimation is proposed respectively to improve the

hydraulic pressure regulation. Furthermore, ABS is also one of the studies in automotive brake dynamics control. The performance of ABS is of great significance to vehicle braking safety, and the study of ABS control strategies has been an active area. Besides preventing front wheel lock-up leading to loss of control over vehicle steering, current ABS also have the function of keeping the slip rate of the wheels near the optimal value during the braking process. Except for the common logic threshold method ABS control strategy [12], several researchers have proposed control strategies such as PID control [13], sliding mode variable structure control [14], fuzzy control and Deep learning [15], [16]. The PID controller is widely used in ABS due to its simple algorithm and good robustness, but its accuracy is low compared to advanced controllers. Compared with PID controllers, sliding mode variable structure controllers are theoretically more stable and robust. However, the sliding mode variable structure controller generates jitter, which is a major disadvantage. Fuzzy controllers do not require an accurate mathematical model and adapt to the conditions of nonlinear and dynamic feature changes. Due to its fuzzy processing of information, it leads to reduced control accuracy and poor dynamic characteristics. Deep learning provides excellent performance on complex and nonlinear control problems and has strong learning and adaptive capabilities, and it is gradually being applied to ABS. However, a large amount of data is required to train the deep learning model and it is difficult to select the best network architecture for a given task. The dynamic response of the braking system is crucial in determining the fast, accurate and stable braking of the vehicle. The braking system was supposed to respond quickly and control precisely during braking. However, it is clear that fast response and precise control are contradictory. Fast response inevitably affects the accuracy of the braking control. Therefore, it is necessary to comprehensively consider both the speed of response and control accuracy to achieve fast, accurate, stable and controllable dynamic response of the braking system.

In recent years, there has been some research around the control problems of BBW systems, in terms of low-level component design and control optimization, operating parameters and smoothness, and component coordination.

There has been some relevant research on the control problems of power-assisted motors, hydraulic valves, brake actuators and other components of the braking system. Such as the following: optimization and control of high-efficiency power-assisted motors for low-cost mass production and the servo control of braking pressure, etc., [17]–[19]. Hydraulic valve switching characteristics and linear control, ABS cascade brake hydraulic valve control method [11], [20]–[23]. A control method for braking system friction modeling and friction compensation to improve braking accuracy [9], [24]. The braking method of operation parameter optimization, which is influenced by dynamic change of load, loss of battery and motor, brake sensation adjustment and other factors [25]–[29]. For comfort, braking force optimization, jitter compensation, emergency braking control improvement,

etc., [30]–[34]. Cooperative control methods of braking process, such as braking system coordinated shift reduction, cruise of acceleration and braking, braking force and feedback force coordination, etc., [35]–[38]. However, current research does not take advantage of the intelligent connected and flexible controlled benefits of the BBW system for intelligent connected EVs, which uses data to intelligently predict and solve optimization problems efficiently in real time.

The distribution of braking force is related to braking stability and energy efficiency and has been the focus of academic attention. It is a feasible method for efficient braking of intelligent connected EVs to combine networked and perceived information for collaborative optimization control to improve the energy efficiency of the vehicle and the life of power components. The distribution of braking force can be optimized by cooperative upper network perception wire control and driving intent. As shown in Fig 4. Braking distance and predictive control are estimated by reinforcement learning predictive compensation. Braking influencing factors such as brake input signals, vehicle status information, and road adhesion coefficient are input to the operational data value network. The output value functions and vehicle condition feedback parameters are evaluated and updated into the operational data value network. On the other hand, the value function is optimized and input to the control strategy value network to explore the adaptive control strategy. The braking system inverse model is developed by braking distance margin estimation and predictive control. In the brake process, a reference model is built and a reference slip rate is calculated based on the braking influence parameters. Finally, the braking force is allocated secondly to obtain the desired deceleration.

Despite the great development of BBW systems for intelligent connected EVs, the following issues in the current research of BBW systems should be addressed: (1) Most of the existing research focuses on the optimization of methods for a certain point (such as braking force, hydraulic pressure and motor optimization), and there is a lack of systematic methods in the efficient use of braking energy. (2) There is a problem of control crosstalk in multiple systems, which can not to effectively coordinate intelligent perception and network connection information to optimize the underlying electronic control principle. (3) A large number of studies focus on the optimization control of a single system, lacking the optimization method of electromechanical integrated coordinated control, and the collaborative optimization mechanism of the whole vehicle from the bottom to the system needs further study.

V. CONTROL METHODS OF BRAKE-BY-WIRE SYSTEM: DYNAMICS AND KINEMATICS CONTROL

Fig 5 depicts the future trend of control methods, including braking dynamics control and regenerative braking force distribution control. The control method of Braking dynamics is aimed at tracking braking intention, vehicle stability and comfort [39]. The existing main methods used for

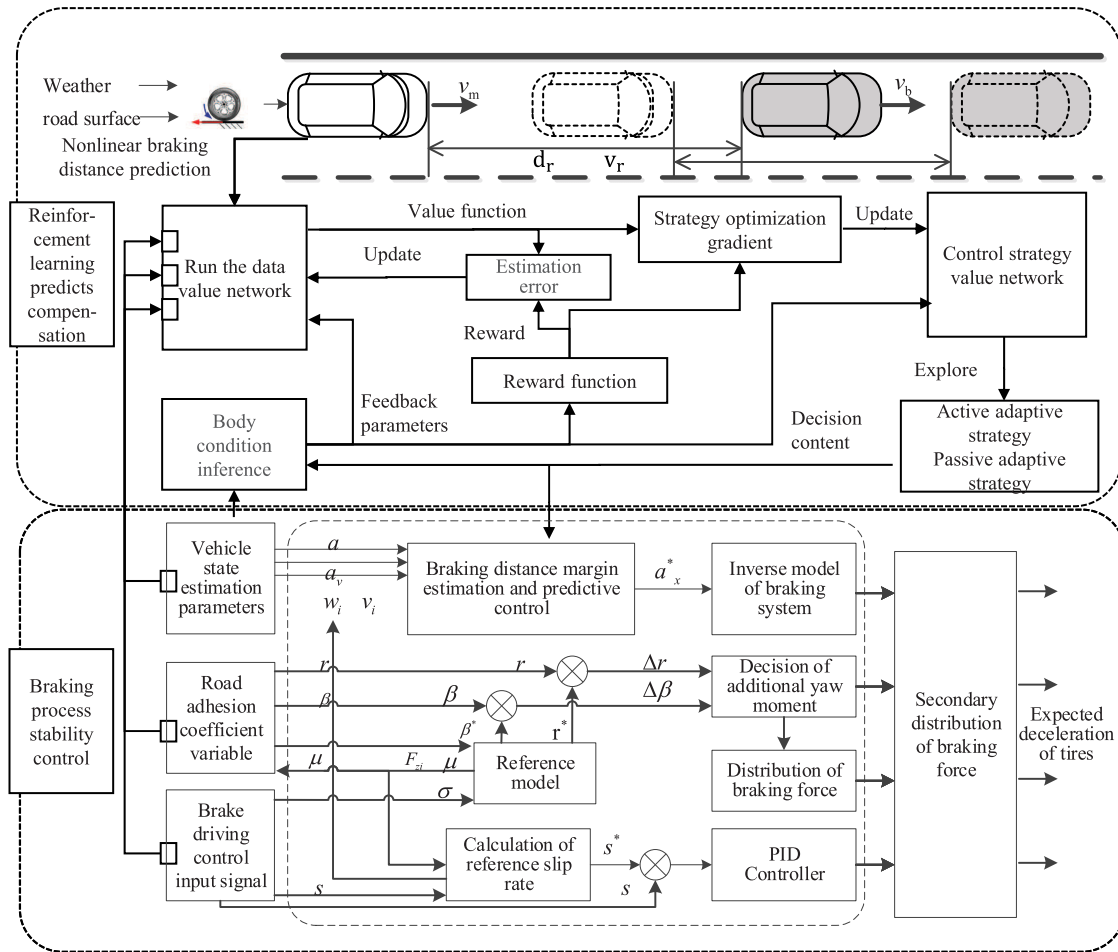

FIGURE 4. Cooperative upper network perception wire control and driving intent.

dynamic control of braking processes are divided into traditional direct control structures and upper and lower control structures. The traditional direct control methods, including nonlinear PID, fuzzy matrix inequalities and variable structure robust control, have the strengths of high integration and accuracy, and are widely used to improve the stability and performance of vehicle dynamics, but it has obvious weaknesses in terms of development and flexibility. Although the upper and lower control structure of low difficulty and few structural variables, it has low integration and increased hierarchical operation. In summary, current braking control methods are unable to meet simple and efficient braking requirements. The self-learning method will be the future direction of braking control methods due to the application of techniques such as reinforcement learning and deep neural networks in the field of braking control [40]–[42], [49]. The ability of self-learning methods to self-optimize the behavior from the data and adapt to new scenarios makes the self-learning method highly suitable for control problems in complex and dynamic environments. Therefore, self-learning methods are gradually being applied to control fields such as braking intention prediction and braking force optimization. Yang Xing *et al.* developed an integrated time series

model (TSM) based on deep recurrent neural network (RNN) for dynamic estimation of braking pressure in EVs, which can achieve more reliable multi-step prediction with higher accuracy [43]. Meanwhile, as the braking system integrates more functions and becomes more intelligent, braking control method has higher data requirements and higher model dependency, which are also problems faced by self-learning methods.

The control method of regenerative braking force distribution optimizes the control with the target of ideal braking recovery curve to ensure braking performance and improve energy recovery efficiency [44]. Among the current control methods of regenerative braking force distribution, the proportional control methods, such as threshold judgment and threshold area control, have obvious advantages in the case of emergency braking, and rule logic control methods such as fuzzy logic control and binary rules meet the demand for easy implementation and controllability. However, proportional control and rule logic control have several disadvantages such as poor applicability, low energy efficiency, and inflexibility. To respond to these problems, dynamic optimal control method optimizes the braking force distribution with reliable algorithms to distribute the braking force as

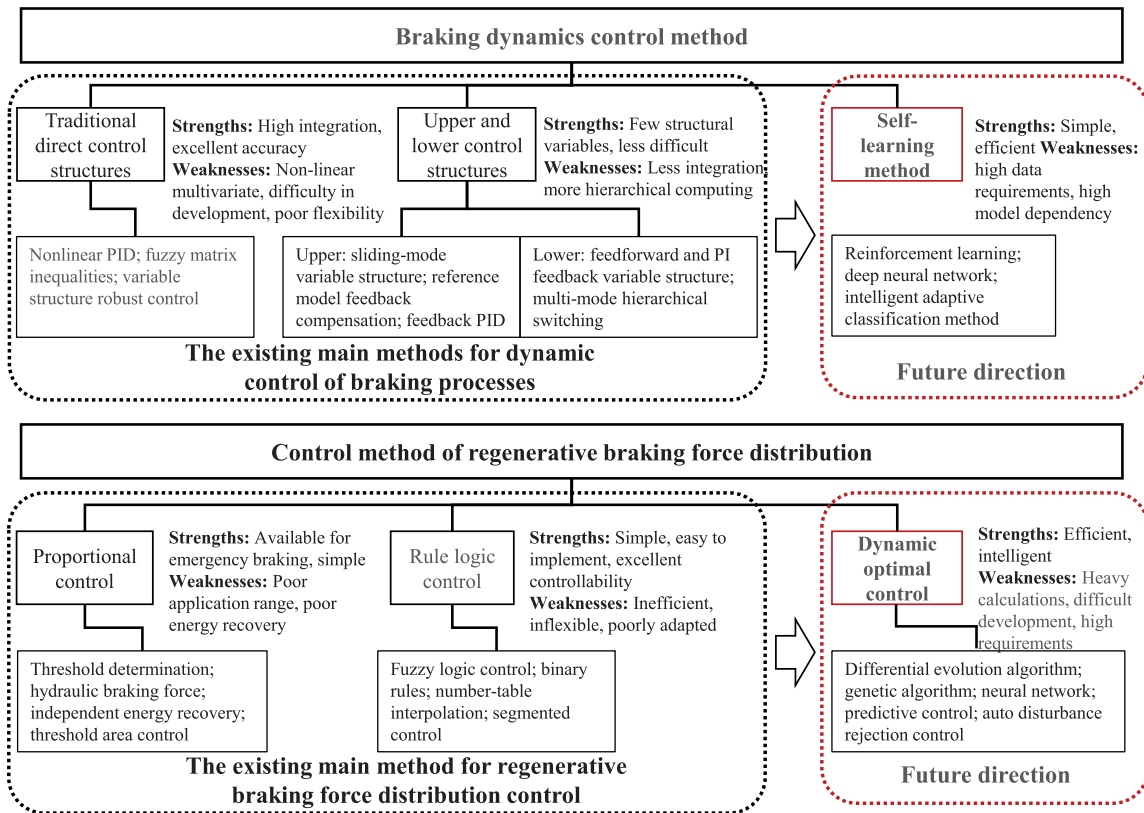

FIGURE 5. Trend of control method for BBW system.

close to the ideal brake recovery curve as possible even under dynamic conditions. On the other hand, the control of complex conditions also presents a number of challenges such as computational complexity and development difficulties, which will also be solved in the future. Nevertheless, the dynamic optimization control method has the superiority of high efficiency and intelligence compared to the current control method of braking force distribution, and is the future trend.

The BBW process of intelligent connected EVs not only needs to realize stability control, but also needs to realize efficient recovery of braking energy [45], [46]. As the brake control becomes more complex, the motor is required to precisely and rapidly control the brake fluid pressure to improve the dynamic pressure building response and adapt to the requirements of BBW and high proportion energy recovery [47], [48]. Moreover, high-efficiency brake energy recovery needs to consider the impact of battery status on power and efficiency, as well as the impact of brake wear and current impact on the life of parts [49]. The comprehensive energy efficiency of BBW process is also affected by factors such as empty travel caused by brake component loss, hydraulic nonlinearity caused by brake fluid state change, and dynamic disturbance caused by sensor accuracy drift, etc. In order to realize the efficient recovery and safety control of braking energy of intelligent connected EVs, it is necessary to study the linkage operation mechanism of braking machinery, hydraulic pressure, motor and battery, the optimal

parameters, as well as the interaction effect of vehicle working conditions and other factors [50].

Part of the braking force is used for friction braking and the other part for regenerative braking. The braking force used for friction braking should be properly distributed to each wheel of the vehicle to ensure stable deceleration of the vehicle. Therefore, the distribution of braking force has an essential effect on the braking safety and energy recovery ratio. Increased energy efficiency can be achieved by allocating more braking power to regenerative braking, based on the situation of braking safety. Fig 6 depicts the optimal control method for braking energy. The braking energy regeneration ratio is determined by the driving state of the vehicle, the state of the battery and the input signal. In the braking process, a braking mechanical structure model and a hydraulic booster response model are developed by analyzing the dynamic forces and impact wear of the vehicle. The booster motor controller generates hydraulic braking force from the master cylinder according to the mechanical torque and the brake-mechanical structure model, and the braking force is appropriately distributed to each wheel. In addition, the drive motor controller transmits the motor torque to the drive train. Braking is achieved through friction dynamics and kinematic feedback. For the battery state, the energy recovery ratio is influenced by several factors such as battery charging and discharging efficiency, motor efficiency, as well as mechanical and frictional losses. The energy conversion ratio is corrected by the recovery ratio curve correction.

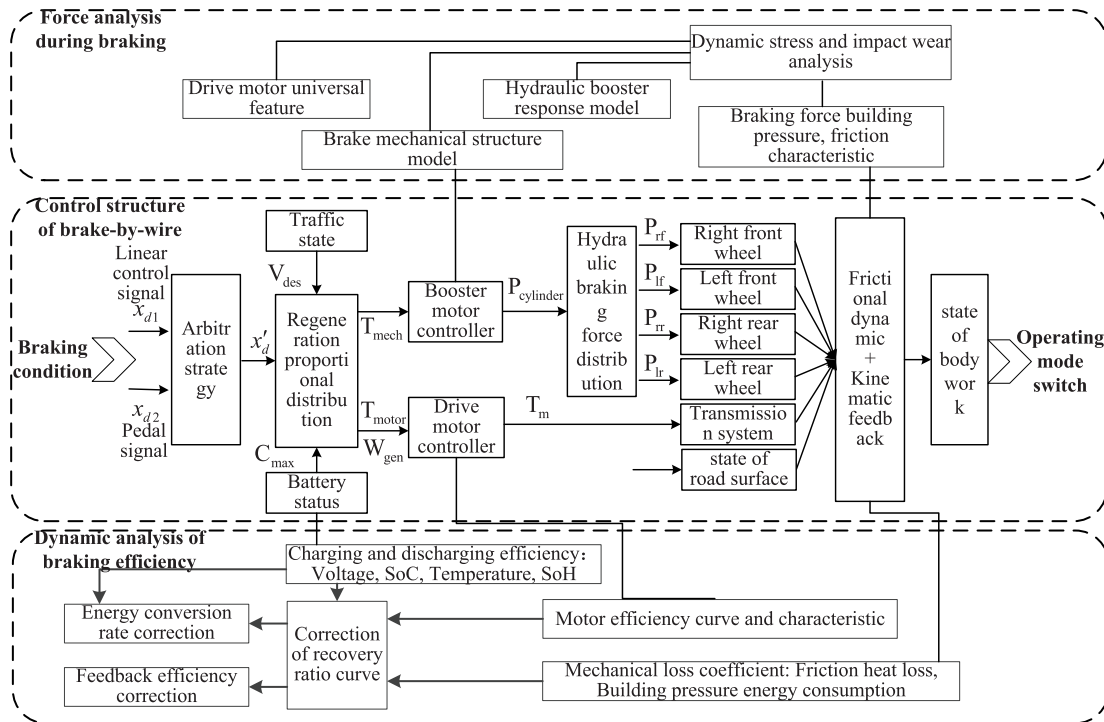

FIGURE 6. Control method of BBW system.

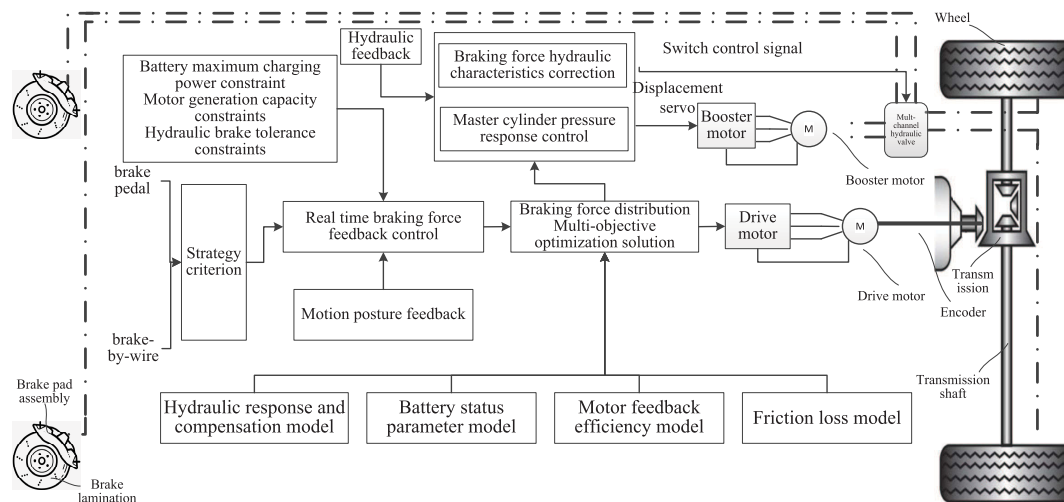

FIGURE 7. Control strategy of BBW system.

VI. CONTROL STRATEGY OF BRAKE-BY-WIRE SYSTEM: BRAKING SAFETY AND BRAKING ENERGY RECOVERY

Research on braking safety and braking energy recovery are two of the most important topics of braking system. The safety of the car should be considered firstly in the design of braking system, including fast speed reduction and maintain the stability of the braking direction [53], [54]. These specific requirements of the safety for braking force are to provide sufficient braking force on each wheel and to distribute the braking force appropriately. In order to improve the energy efficiency of the vehicle, the design of the braking system needs to consider braking energy recovery. In EVs,

mechanical friction braking and electro-regenerative braking exist simultaneously [55]. There are various control strategies for this hybrid braking system, which are designed with the objectives of ensuring the braking performance of the vehicle and recovering as much of the braking energy as possible [56]. These two objectives often require different braking force distributions. Therefore, the braking control strategy is designed to find the appropriate balance between them according to the objectives.

When the braking force of front and rear wheels is distributed according to the ideal braking force distribution curve, the adhesion condition of the ground can be fully

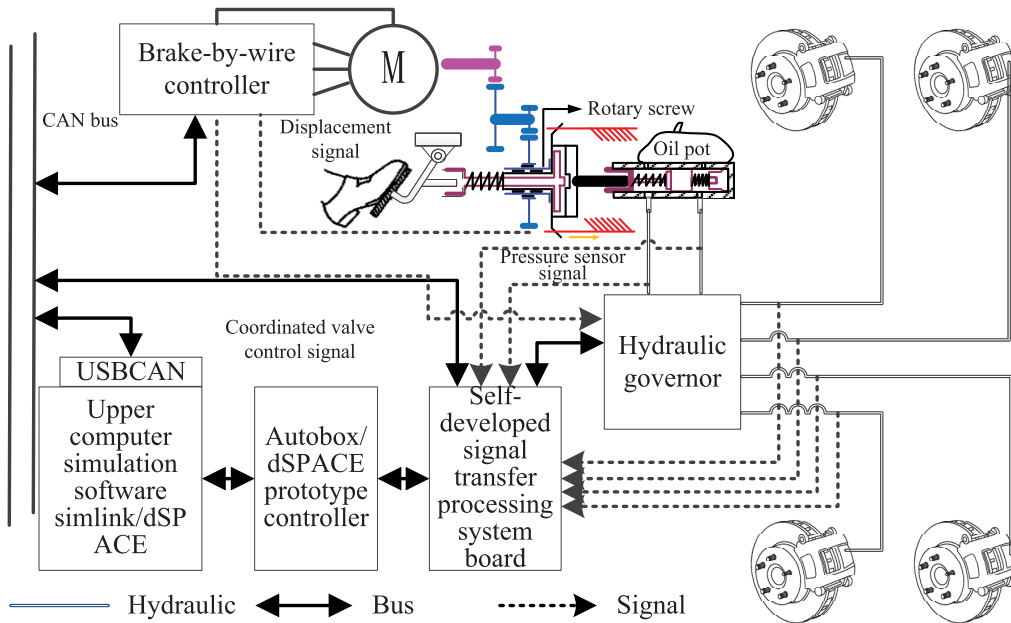

FIGURE 8. Building pressure test platform of BBW system.

utilized to achieve the purpose of rapid braking and directional stability [57]. However, the appropriate braking force allocation is influenced by many factors. Fig 7 depicts the method of coordinated control of the mid-level hydraulic and electric brakes. When there is a braking signal input, it is determined based on the strategy whether it is a pedal signal or drive-by-wire signal, and the braking force is feedback in real time. Therein, the maximum battery charging power, motor generating capacity and hydraulic braking tolerance are the constraints for braking force feedback. The system calculates and optimizes the distribution of braking force according to the feedback braking force and models (hydraulic response and compensation model, battery state parameter model, motor feedback efficiency model, friction loss model). For the optimized braking force, one part is distributed to the drive motor and another part to the master cylinder and generates brake hydraulic pressure, which is distributed to each wheel via the hydraulic valve.

The pressure building test platform and the network connection platform were built according to the control strategy. Fig 8 depicts the pressure building test platform, including the upper computer simulation software, prototype controller, signal transfer processing system board and BBW system. By combining theoretical modeling with experimental modeling, the upper computer simulation software was used to build the simulation model. The signal transfer processing system board is responsible for processing signals as the information intermediary. When the displacement signal is detected, the platform builds a hydraulic model to test the braking force of the four wheels.

The network connection platform is shown in Fig 9. This platform tests the performance of BBW system for intelligent connected EVs through vehicle driving simulation, including

driver control simulation, road load simulation, intelligent connected information simulation and vehicle dynamics simulation. The platform simulates the driver to operate the vehicle instead of manual operation, simulates road load and other information, and provides a virtual road driving environment for the vehicle. For power supply, it is powered by the power battery stored in the thermostat, and the power of the power battery is analyzed through Auto Box to check whether the battery works normally. Meanwhile, to improve energy efficiency, a power dynamometer is used to convert the mechanical energy generated by the drive motor into electrical energy and feed it back to the control cabinet.

VII. THE EXISTING PROBLEMS AND IMPORTANT COUNTERMEASURES OF CURRENT TECHNOLOGY

BBW systems suffer from unpredictable failures during operation since the traditional mechanical or hydraulic connections between pedal and wheel actuators have been replaced by cables and wires, and the construction and control of BBW systems have become more complex [58]. Therefore, there is still a lot of room for development in the integrated control of BBW systems in order to solve the existing problems of current technology and to meet the future demands for braking performance.

The integration of additional functions can greatly improve the performance and energy efficiency of EVs, but it also faces several problems such as complex control and structural complexity [59]. In response to these problems, the reliability of the system is increased by means of a reliable control strategy on the one hand and the reduction of redundant components by optimizing the system structure on the other hand [60]–[62]. The control strategy of BBW systems for complex coupled braking processes needs to consider

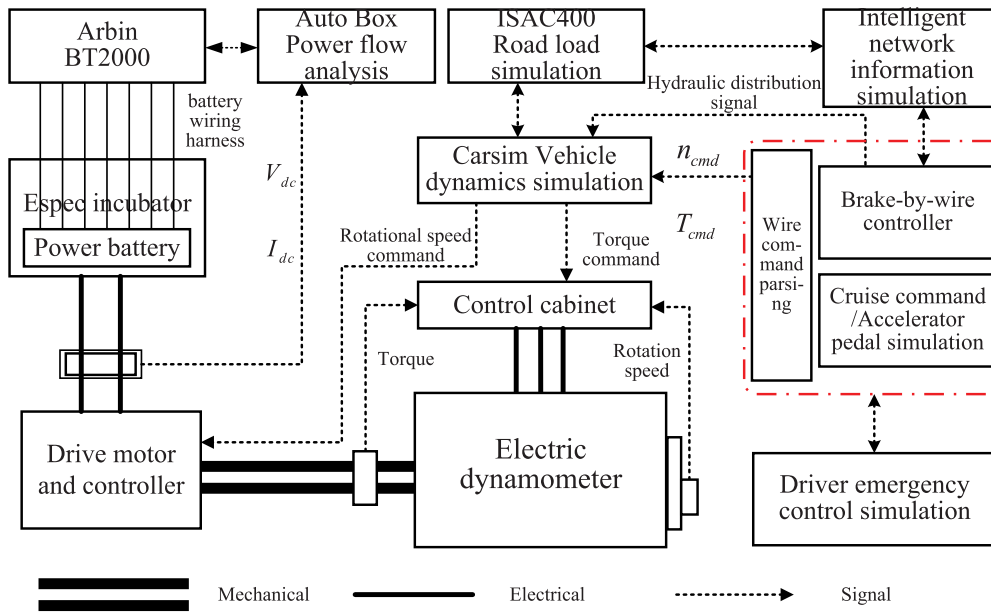

FIGURE 9. Network connection platform of BBW system.

the balance between braking safety, braking reliability and energy efficiency [63], [64]. Meanwhile, the control strategy of BBW also needs to consider both fast response and precise control. However, fast response and precise control are contradictory. The fast response of the braking system will inevitably affect the accuracy of the control. Therefore, it is necessary to consider both fast response and precise control and to find the optimal balance between them. In addition, sudden changes in braking torque during braking make the driver feel uncomfortable [65]. Although studies on braking comfort and steering stability have been conducted, there is a lack of in-depth research. In order to avoid the fault of the braking system during operation that threatens the safety of the system, on the one hand, the BBW system can maintain safe operation and maintain a certain quality index through fault-tolerant technology to achieve high reliability of the BBW system in spite of partial faults [66]. On the other hand, real-time vehicle detection and diagnosis through fault diagnosis technology, and remind the driver to repair the fault in time.

In terms of CAN technology and sensor technology. The information communication of BBW system relies heavily on CAN technology, which can greatly improve the speed of data transmission between each control module. In BBW system, the speed of sensor collection and feedback accuracy directly affect the performance of the BBW system [67]. Therefore, high performance and intelligence become the development direction of the sensor in order to meet the requirement of accurate and timely collection of information for intelligent connected EVs.

Fig 10 depicts the problems of BBW system for intelligent connected EVs in terms of vehicle manufacturing, control system, and test regulations. Integration function, simplification of structure and reduction of manufacturing cost are

the current issues for vehicle manufacturing. The motor will develop in the direction of integration with increased braking functions and improved performance. Lightweight structures allow redundant parts to be reduced and vehicle manufacturing costs to be lowered. For the control system, braking safety, stability, comfort, and energy recovery efficiency should be improved. What is more, the vehicles are subject to local vehicle testing regulations. Vehicle technical standards and regulation systems are mandatory requirements for vehicles to enter local markets. Several countries and regions have proposed technical regulations in terms of vehicle safety, brake safety, electric motor drive, etc. The Economic Commission for Europe (ECE) promulgated the ECE regulations in 1958, which have been amended and supplemented continuously to put forward uniform requirements on the safety of vehicles and their components and environmental protection, etc. The ECE regulations have a wide range of implications for the vehicle management system in other countries and regions of the world, and the vehicle regulations of a large number of countries around the world are basically formulated with reference to the ECE regulation system. In terms of motor and drive regulations, ECE has promulgated the ECE R85 regulation for the net power or electric drive mechanism of internal combustion engines for driving category M and N vehicles, which has been adopted by several countries. For motor drive systems, China has promulgated GB/T 18488 and QC/T 893-2011 regulations, which stipulate the working system, requirements, inspection, etc. of drive motor systems for EVs, as well as the identification and classification of drive motor system faults, respectively. In the field of brake hydraulics, the GB 12981-2003 regulation proposed by China specifies the requirements and testing of brake fluid for vehicle hydraulic brake systems. In addition, the US FMVSS 105 and FMVSS 116 regulations also specify the hydraulic

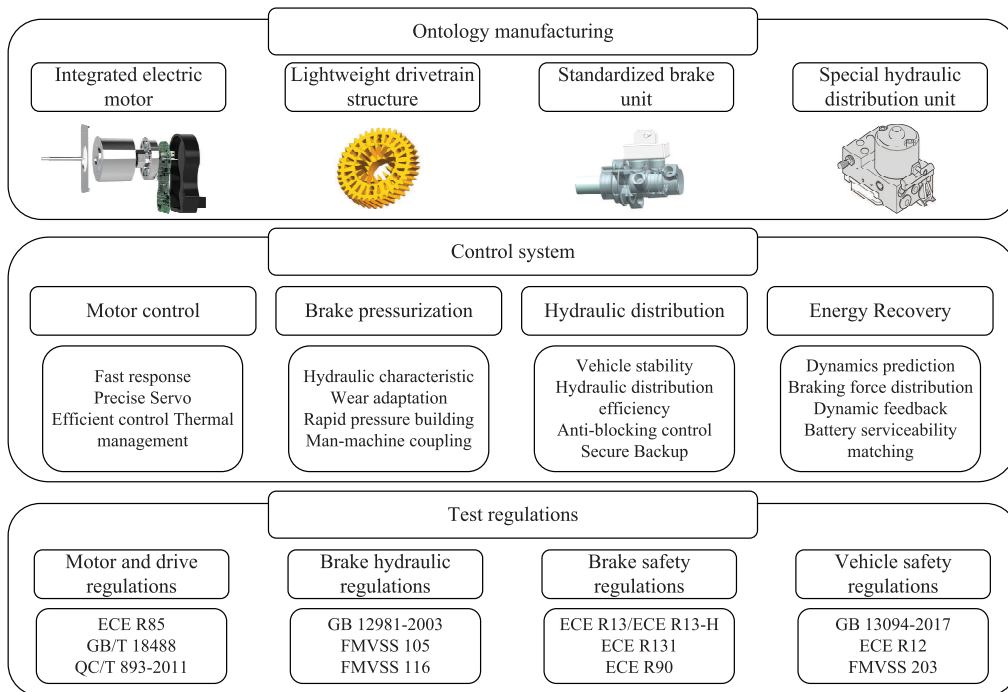

FIGURE 10. Other issues of BBW System for intelligent connected EVs.

requirements for brake systems. In terms of brake safety, the ECE regulations for brake systems and components include ECE R13, ECE R13H, ECE R131, and ECE R90. ECE R13 and ECE R13H have detailed definitions, technical requirements, and test programs for brake systems in commercial and passenger vehicles. ECE R131 establishes consistent requirements for vehicle emergency braking systems, and ECE R90 specifies standards for alternate braking system components. For vehicle safety, the United States was the first to develop regulations. FMVSS 203 establishes requirements for vehicle crash protection. In Europe, meanwhile, ECE R12 was enacted to prevent driver injury to the steering mechanism in the event of a vehicle collision. In China, GB 13094-2017 specifies safety requirements for passenger car structures. Although each country has developed its own testing regulations, with the development of globalization, mutual recognition and unification of national automotive regulations is the trend of global automotive regulations.

VIII. CONCLUSION

The purpose of this paper is to provide an overview of the key technologies of BBW systems for intelligent connected EVs, including core components, control methods and control strategies. The BBW system has an increasing proportion of active control during the braking process compared to conventional braking systems. Consequently, the control method becomes a key technology for the precise and fast regulation of BBW systems. In terms of energy efficiency and braking stability, it depends to a large extent on its braking control strategy. It is also a big challenge for the control strategy of BBW systems to deal with variations in system parameters under complex conditions and external disturbances.

For future work, the research will focus on the following areas: first, research on optimal braking control based on machine learning control strategies; second, research and development of non-passenger autonomous vehicles. Utilizing the learning capability of machine learning for model training and optimal control of braking smoothness and braking force distribution. On the other hand, for the emerging field of automated driving, future work will develop non-passenger automated vehicles to replace transportation or sweeping vehicles that require human drivers.

REFERENCES

- [1] D. Yang, K. Jiang, D. Zhao, C. Yu, Z. Cao, S. Xie, Z. Xiao, X. Jiao, S. Wang, and K. Zhang, "Intelligent and connected vehicles: Current status and future perspectives," *Sci. China Technol. Sci.*, vol. 61, no. 10, pp. 1446–1471, Oct. 2018.
- [2] IEA, Paris. (2019). *Global EV Outlook 2019*. [Online]. Available: <https://www.iea.org/reports/global-ev-outlook-2019>
- [3] T. Li, Q. Shi, Z. Lei, L. He, and B. Liu, "Research on mechanism and key technology of intelligent vehicles brake by wire system," in *Proc. 3rd Conf. Vehicle Control Intell. (CVCI)*, Sep. 2019, pp. 1–8.
- [4] X. Gong, W. Ge, J. Yan, Y. Zhang, and X. Gongye, "Review on the development, control method and application prospect of brake-by-wire actuator," *Actuators*, vol. 9, no. 1, p. 15, Mar. 2020.
- [5] L. Yu, X. Liu, Z. Xie, and Y. Chen, "Review of brake-by-wire system used in modern passenger car," in *Proc. Int. Design Eng. Tech. Conf. Comput. Inf. Eng. Conf.*, vol. 50138. New York, NY, USA: American Society Mechanical Engineers, 2016, Art. no. V003T01A020.
- [6] K. Prajapati, R. Vibhandik, D. Baria, Y. Patel, and I. G. Detail, "Electromagnetic braking system," *Int. J. Sci. Res. Eng.*, vol. 1, p. 3, Mar. 2017.
- [7] C. Vey, "Brake systems 2025—Future trends," in *Proc. 9th Int. Munich Chassis Symp.* Wiesbaden, Germany: Springer-Vieweg, 2019, pp. 617–631.
- [8] B. Szewczyk, A. Ciotti, and L. Cappelletti, "Distributed brake-by-wire system for next-generation road vehicles," in *Proc. 9th Int. Munich Chassis Symp.* Wiesbaden, Germany: Springer-Vieweg, 2019, pp. 633–644.

- [9] H. E. Rui, W. U. Jian, and G. A. O. Ji, "Modeling and compensation control for fiction in vehicle power assisted braking system," *Automot. Eng.*, vol. 39, no. 6, pp. 683–688, 2017.
- [10] C. Lv, H. Wang, and D. Cao, "High-precision hydraulic pressure control based on linear pressure-drop modulation in valve critical equilibrium state," *IEEE Trans. Ind. Electron.*, vol. 64, no. 10, pp. 7984–7993, Oct. 2017.
- [11] X. Zhao, L. Li, J. Song, C. Li, and X. Gao, "Linear control of switching valve in vehicle hydraulic control unit based on sensorless solenoid position estimation," *IEEE Trans. Ind. Electron.*, vol. 63, no. 7, pp. 4073–4085, Jul. 2016.
- [12] Z. Xiu-Qin, Y. Bo, Y. Chao, and X. Guan-Neng, "Research on ABS of multi-axle truck based on ADAMS/car and MATLAB/simulink," in *Proc. 2nd SREE Conf. Eng. Modelling Simulation (CEMS)*, Jun. 2012.
- [13] F. Jiang and Z. Gao, "An application of nonlinear PID control to a class of truck ABS problems," in *Proc. 40th IEEE Conf. Decis. Control*, vol. 1, Dec. 2001, pp. 516–521.
- [14] J.-C. Wang and R. He, "Hydraulic anti-lock braking control strategy of a vehicle based on a modified optimal sliding mode control method," *Proc. Inst. Mech. Eng., Part D, J. Automobile Eng.*, vol. 233, no. 12, pp. 3185–3198, Oct. 2019.
- [15] H. Mirzaeinejad, "Robust predictive control of wheel slip in antilock braking systems based on radial basis function neural network," *Appl. Soft Comput.*, vol. 70, pp. 318–329, Sep. 2018.
- [16] A. Aksjonov, V. Vodovozov, and E. Petlenkov, "Design and experimentation of fuzzy logic control for an anti-lock braking system," in *Proc. 15th Biennial Baltic Electron. Conf. (BEC)*, Oct. 2016, pp. 207–210.
- [17] J. Zhao, Z. Hu, and B. Zhu, "Pressure control for hydraulic brake system equipped with an electro-mechanical brake booster," SAE Tech. Paper 2018-01-0829, 2018.
- [18] J. Zhao, Z. Chen, B. Zhu, and J. Wu, "Precise active brake-pressure control for a novel electro-booster brake system," *IEEE Trans. Ind. Electron.*, vol. 67, no. 6, pp. 4774–4784, Jun. 2020.
- [19] Z. Yu, W. Han, S. Xu, and L. Xiong, "Review on hydraulic pressure control of electro-hydraulic brake system," *J. Mech. Eng.*, vol. 53, no. 14, pp. 1–15, Jul. 2017.
- [20] H. Liu, R. He, J. Wu, W. Sun, and B. Zhu, "Linear electro-magnetic valve characteristic analysis and precise pressure control of the electro-hydraulic brake system," SAE Tech. Paper 2016-01-0093, 2016.
- [21] L. Li, X. Li, X. Wang, Y. Liu, J. Song, and X. Ran, "Transient switching control strategy from regenerative braking to anti-lock braking with a semi-brake-by-wire system," *Vehicle Syst. Dyn.*, vol. 54, no. 2, pp. 231–257, Feb. 2016.
- [22] L. Tianyang, Y. Zhuoping, X. Lu, H. Wei, and W. Jingjia, "Anti-lock braking control for integrated electro-hydraulic braking system," *Automot. Eng.*, vol. 7, no. 7, p. 7, 2017.
- [23] Y. Du, C. Qin, S. You, and H. Xia, "Efficient coordinated control of regenerative braking with pneumatic anti-lock braking for hybrid electric vehicle," *Sci. China Technol. Sci.*, vol. 60, no. 3, pp. 399–411, Mar. 2017.
- [24] J.-W. Yong, F. Gao, N.-G. Ding, and Y.-P. He, "Pressure-tracking control of a novel electro-hydraulic braking system considering friction compensation," *J. Central South Univ.*, vol. 24, no. 8, pp. 1909–1921, Aug. 2017.
- [25] Z. Zhang, L. Wang, J. Zhang, and R. Ma, "Study on requirements for load emulation of the vehicle with an electric braking system," *IEEE Trans. Veh. Technol.*, vol. 66, no. 11, pp. 9638–9653, Nov. 2017.
- [26] L. Zhang, C. Ruan, and D. Meng, "The influence of vacuum booster design parameters on brake pedal feel," *SAE Int. J. Passenger Cars-Mech. Syst.*, vol. 7, no. 4, pp. 1311–1320, Sep. 2014.
- [27] D.-J. Meng, L. J. Zhang, M. X. Fang, and Z. P. Yu, "Master cylinder dynamic model for brake pedal feeling and its key factors," *J. Jilin Univ., Eng. Technol. Ed.*, no. 5, Sep. 2015.
- [28] H. Xiong, X. Zhu, and R. Zhang, "Energy recovery strategy numerical simulation for dual axle drive pure electric vehicle based on motor loss model and big data calculation," *Complexity*, vol. 2018, pp. 1–14, Aug. 2018.
- [29] A.-C. Pop, J. J. C. Gyselinck, D. E. Pinto, and I. Vintiloiu, "Optimization of low-power brushless PM-machines for automotive applications with focus on high-volume mass production," *IEEE Trans. Ind. Electron.*, vol. 64, no. 12, pp. 9767–9775, Dec. 2017.
- [30] D. Lao, J. Wu, R. He, B. Zhu, J. Zhao, and Z. Chen, "Research on yaw stability control of unmanned vehicle based on integrated electromechanical brake booster," SAE Tech. Paper 2020-01-0212, 2020.
- [31] J. Zhang, W. Sun, Z. Liu, and M. Zeng, "Comfort braking control for brake-by-wire vehicles," *Mech. Syst. Signal Process.*, vol. 133, Nov. 2019, Art. no. 106255.
- [32] N. Pan, "Anti-lock braking control in coordinated braking system considering braking comfort," *J Zhejiang Univ. (Eng. Sci.)*, vol. 51, no. 1, pp. 9–16, 2017.
- [33] P. Spichartz and C. Sourkounis, "Brake force distributions optimised with regard to energy recovery for electric vehicles with single front-wheel drive or rear-wheel drive," *IET Electr. Syst. Transp.*, vol. 9, no. 4, pp. 186–195, Dec. 2019.
- [34] R. A. Dollar and A. Vahidi, "Efficient and collision-free anticipative cruise control in randomly mixed strings," *IEEE Trans. Intell. Vehicles*, vol. 3, no. 4, pp. 439–452, Dec. 2018.
- [35] Z. Yu, B. Shi, L. Xiong, W. Han, and Q. Shu, "Coordinated control of hybrid braking based on integrated-electro-hydraulic brake system," *J. Tongji Univ. Nat. Sci. Ed.*, vol. 47, no. 6, pp. 851–856, Jun. 2019.
- [36] J. Liang, P. D. Walker, J. Ruan, H. Yang, J. Wu, and N. Zhang, "Gearshift and brake distribution control for regenerative braking in electric vehicles with dual clutch transmission," *Mechanism Mach. Theory*, vol. 133, pp. 1–22, Mar. 2019.
- [37] D. Wu, B. Zhu, D. Tan, N. Zhang, and J. Gu, "Multi-objective optimization strategy of adaptive cruise control considering regenerative energy," *Proc. Inst. Mech. Eng., Part D, J. Automobile Eng.*, vol. 233, no. 14, pp. 3630–3645, 2019.
- [38] J. Ko, S. Ko, H. Son, B. Yoo, J. Cheon, and H. Kim, "Development of brake system and regenerative braking cooperative control algorithm for automatic-transmission-based hybrid electric vehicles," *IEEE Trans. Veh. Technol.*, vol. 64, no. 2, pp. 431–440, Feb. 2015.
- [39] M. Doumiati, O. Sename, L. Dugard, J.-J. Martinez-Molina, P. Gaspar, and Z. Szabo, "Integrated vehicle dynamics control via coordination of active front steering and rear braking," *Eur. J. Control*, vol. 19, no. 2, pp. 121–143, Mar. 2013.
- [40] H. Chae, C. M. Kang, B. Kim, J. Kim, C. C. Chung, and J. W. Choi, "Autonomous braking system via deep reinforcement learning," in *Proc. IEEE 20th Int. Conf. Intell. Transp. Syst. (ITSC)*, Oct. 2017, pp. 1–6.
- [41] Q. Zhu, Z. Huang, Z. Sun, D. Liu, and B. Dai, "Reinforcement learning based throttle and brake control for autonomous vehicle following," in *Proc. Chin. Autom. Congr. (CAC)*, Oct. 2017, pp. 6657–6662.
- [42] S. John and J. O. Pedro, "Neural network-based adaptive feedback linearization control of antilock braking system," *Int. J. Artif. Intell.*, vol. 10, no. 13, pp. 21–40, 2013.
- [43] Y. Xing and C. Lv, "Dynamic state estimation for the advanced brake system of electric vehicles by using deep recurrent neural networks," *IEEE Trans. Ind. Electron.*, vol. 67, no. 11, pp. 9536–9547, Nov. 2020.
- [44] Z. Ma and D. Sun, "Energy recovery strategy based on ideal braking force distribution for regenerative braking system of a four-wheel drive electric vehicle," *IEEE Access*, vol. 8, pp. 136234–136242, 2020.
- [45] S. Ko, C. Song, and H. Kim, "Cooperative control of the motor and the electric booster brake to improve the stability of an in-wheel electric vehicle," *Int. J. Automot. Technol.*, vol. 17, no. 3, pp. 447–456, Jun. 2016.
- [46] C. Lv, J. Zhang, Y. Li, and Y. Yuan, "Mechanism analysis and evaluation methodology of regenerative braking contribution to energy efficiency improvement of electrified vehicles," *Energy Convers. Manage.*, vol. 92, pp. 469–482, Mar. 2015.
- [47] M. C. Gross, J. Hamermesh, K. Jonson, and J. Alden, "Electronic control of brake and accelerator pedals for precise efficiency testing of electrified vehicles," SAE Tech. Paper 2020-01-1282, 2020.
- [48] S. Heydari, P. Fajri, M. Rasheduzzaman, and R. Sabzehgar, "Maximizing regenerative braking energy recovery of electric vehicles through dynamic low-speed cutoff point detection," *IEEE Trans. Transport. Electrific.*, vol. 5, no. 1, pp. 262–270, Mar. 2019.
- [49] J. Wu, X. Wang, L. Li, C. Qin, and Y. Du, "Hierarchical control strategy with battery aging consideration for hybrid electric vehicle regenerative braking control," *Energy*, vol. 145, pp. 301–312, Feb. 2018.
- [50] Q.-Y. Zhang and J. Huang, "Research on regenerative braking energy recovery system of electric vehicles," *J. Interdiscipl. Math.*, vol. 21, no. 5, pp. 1321–1326, Jul. 2018.
- [51] H. He, C. Wang, H. Jia, and X. Cui, "An intelligent braking system composed single-pedal and multi-objective optimization neural network braking control strategies for electric vehicle," *Appl. Energy*, vol. 259, Feb. 2020, Art. no. 114172.
- [52] Y. Yuan and J. Zhang, "A novel initiative braking system with nondegraded fallback level for ADAS and autonomous driving," *IEEE Trans. Ind. Electron.*, vol. 67, no. 6, pp. 4360–4370, Jun. 2020.
- [53] X. He, K. Yang, X. Ji, Y. Liu, and W. Deng, "Research on vehicle stability control strategy based on integrated-electro-hydraulic brake system," SAE Tech. Paper 2017-01-1565, 2017.

- [54] Z. Yu, S. Xu, L. Xiong, and W. Han, "An integrated-electro-hydraulic brake system for active safety," SAE Tech. Paper 2016-01-1640, 2016.
- [55] P. Fajri, S. Lee, V. A. K. Prabhala, and M. Ferdowsi, "Modeling and integration of electric vehicle regenerative and friction braking for motor/dynamometer test bench emulation," *IEEE Trans. Veh. Technol.*, vol. 65, no. 6, pp. 4264–4273, Jun. 2016.
- [56] W. Liu, G. Chen, C. Zong, and C. Li, "Research on electric vehicle braking force distribution for maximizing energy regeneration," SAE Tech. Paper 2016-01-1676, 2016.
- [57] Y. J. Yang, H. Zhao, and M. F. Zhu, "A study on the control strategy for maximum energy recovery by regenerative braking in electric vehicles," *Automot. Eng.*, vol. 35, no. 2, pp. 105–110, 2013.
- [58] W. Xiang, P. C. Richardson, C. Zhao, and S. Mohammad, "Automobile Brake-by-Wire control system design and analysis," *IEEE Trans. Veh. Technol.*, vol. 57, no. 1, pp. 138–145, Jan. 2008.
- [59] Y. Ohtani, T. Innami, T. Obata, T. Yamaguchi, T. Kimura, and T. Oshima, "Development of an electrically-driven intelligent brake unit," SAE Tech. Paper 2011-01-0572, 2011.
- [60] L. Li, Y. Zhang, C. Yang, B. Yan, and C. Marina Martinez, "Model predictive control-based efficient energy recovery control strategy for regenerative braking system of hybrid electric bus," *Energy Convers. Manage.*, vol. 111, pp. 299–314, Mar. 2016.
- [61] S. Zhang, T. Zhang, and S. Zhou, "Vehicle stability control strategy based on active torque distribution and differential braking," in *Proc. Int. Conf. Measuring Technol. Mechatronics Autom.*, vol. 1, Apr. 2009, pp. 922–925.
- [62] M. Yao, J. Miao, S. Cao, S. Chen, and H. Chai, "The structure design and optimization of electromagnetic-mechanical wedge brake system," *IEEE Access*, vol. 8, pp. 3996–4004, 2020.
- [63] F. Sun, W. Liu, H. He, and H. Guo, "An integrated control strategy for the composite braking system of an electric vehicle with independently driven axles," *Vehicle Syst. Dyn.*, vol. 54, no. 8, pp. 1031–1052, Aug. 2016.
- [64] H. Termous, H. Shraim, R. Talj, C. Francis, and A. Charara, "Coordinated control strategies for active steering, differential braking and active suspension for vehicle stability, handling and safety improvement," *Vehicle Syst. Dyn.*, vol. 57, no. 10, pp. 1494–1529, Oct. 2019.
- [65] J. Lee and S. Choi, "Braking control for improving ride comfort," in *Proc. MATEC Web Conf.*, vol. 166, 2018, Art. no. 02002.
- [66] R. Isermann, R. Schwarz, and S. Stolzl, "Fault-tolerant drive-by-wire systems," *IEEE Control Syst.*, vol. 22, no. 5, pp. 64–81, Oct. 2002.
- [67] M. Jo, Y. Baek, K. Kang, S. Lee, and S. H. Son, "Performance analysis of sensor fusion models for brake pedal in a brake-by-wire system," in *Proc. IEEE 31st Int. Conf. Adv. Inf. Netw. Appl. (AINA)*, Mar. 2017, pp. 757–763.
- [68] J. Wu, P. Chen, J. Zhao, and R. He, "Active braking of an electronic brake booster facing intelligent automobile," *Int. J. Performability Eng.*, vol. 14, no. 8, pp. 1735–1744, Aug. 2018.
- [69] W. Li, "Investigation of advanced brake-by-wire systems for electric vehicles," M.S. thesis, School Elect., Comput. Telecommun. Eng., Univ. Wollongong, Keiraville, NSW, Australia, 2019. [Online]. Available: Australia <https://ro.uow.edu.au/theses/1572>
- [70] W. Schaffer, "Electromechanical wheel brake system," U.S. Patent 6 340 077, Jan. 2, 2002.
- [71] E. Nakamura, "Brake control system and control method for brake control system," U.S. Patent 8 708 427, Apr. 29, 2014.
- [72] W. Giering and B. Ohlig, "Electromechanical brake pressure generator for a motor vehicle brake system and motor vehicle brake system," U.S. Patent 11 130 840, Nov. 17, 2005.
- [73] C. Satzger and R. de Castro, "Predictive brake control for electric vehicles," *IEEE Trans. Veh. Technol.*, vol. 67, no. 2, pp. 977–990, Feb. 2018.
- [74] H. Liu, W. Deng, R. He, L. Qian, S. Yang, and J. Wu, "Power assisted braking control based on a novel mechatronic booster," *SAE Int. J. Passenger Cars-Mech. Syst.*, vol. 9, no. 2, pp. 885–891, Apr. 2016.
- [75] C. Mi, H. Lin, and Y. Zhang, "Iterative learning control of antilock braking of electric and hybrid vehicles," *IEEE Trans. Veh. Technol.*, vol. 54, no. 2, pp. 486–494, Mar. 2005.
- [76] W. Zhao, D. Ngoduy, S. Shepherd, R. Liu, and M. Papageorgiou, "A platoon based cooperative eco-driving model for mixed automated and human-driven vehicles at a signalised intersection," *Transp. Res. Part C, Emerg. Technol.*, vol. 95, pp. 802–821, Oct. 2018.
- [77] N. A. Spielberg, M. Brown, N. R. Kapania, J. C. Kegelmann, and J. C. Gerdes, "Neural network vehicle models for high-performance automated driving," *Sci. Robot.*, vol. 4, no. 28, Mar. 2019, Art. no. eaaw1975.
- [78] A. Vahidi and A. Sciarretta, "Energy saving potentials of connected and automated vehicles," *Transp. Res. Part C, Emerg. Technol.*, vol. 95, pp. 822–843, Oct. 2018.



BUMIN MENG (Member, IEEE) received the B.S. degree in electronic and information engineering from the Wuhan University of Science and Technology (WUST), Wuhan, China, in 2008, and the M.S. and Ph.D. degrees in control science and engineering from Hunan University, Changsha, China, in 2011 and 2018, respectively.

He also had worked as an Engineer with the Intelligence Research Institute of Sany. His main research activities are the development of electric vehicles controller and automotive Internet applications.

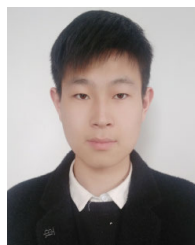

FEIFAN YANG was born in Bozhou, Anhui, China, in 1999. He received the B.S. degree in building electrical and intelligent from Anhui Polytechnic University, and the master's degree in control science and engineering from Xiangtan University, in 2019.

Since 2019, he has been a Research Assistant of intelligent braking system design project of new energy electric vehicle. His research interests include the intelligent and connected vehicles and intelligent brake systems.



JINGANG LIU received the Ph.D. degree in mechanical engineering from Hunan University, in 2008. From 2009 to 2010, he served as a Lecturer with the School of Mechanical Engineering, Xiangtan University, and was promoted to a Professor, in 2015. From 2016 to 2017, he visited the University of Leeds, U.K., as a Public Visiting Scholar. Since 2018, he has been the Director of the Department of Development Planning and Discipline Construction, Xiangtan University.

He concurrently serves as a member of the Youth Working Committee of the Chinese Society of Automotive Engineering, a Senior Member of the Chinese Mechanical Engineering Society. He has presided more than 24 projects at all levels, including the National Natural Science Foundation of China. He has won the first and third prizes of Hunan Science and Technology Progress Award (both ranked first). His research interests include automotive automatic transmission theory and control, and mechatronics-hydraulic integration technology.



YAONAN WANG received the B.S. degree in computer engineering from the East China University of Science and Technology, Fuzhou, China, in 1981, and the M.S. and Ph.D. degrees in control engineering from Hunan University, Changsha, China, in 1990 and 1994, respectively. He was a Postdoctoral Research Fellow with the National University of Defense Technology, Changsha, from 1994 to 1995, a Senior Humboldt Fellow in Germany, from 1998 to 2000, and a Visiting

Professor with the University of Bremen, Bremen, Germany, from 2001 to 2004. He has been a Professor with Hunan University, since 1995. He has been a member of China Engineering Academy, since 2019. His current research interests include robot control, intelligent control and information processing, industrial process control, and image processing.

• • •