

Received September 28, 2020, accepted October 11, 2020, date of publication October 19, 2020, date of current version October 30, 2020.

Digital Object Identifier 10.1109/ACCESS.2020.3032281

An Overview of Microgrids Challenges in the Mining Industry

JUAN S. GÓMEZ¹, JOSE RODRIGUEZ², (Life Fellow, IEEE),
CRISTIAN GARCIA³, (Member, IEEE), LUCA TARISCIOTTI², (Member, IEEE),
FREDDY FLORES-BAHAMONDE², (Member, IEEE), JAVIER PEREDA¹, (Member, IEEE),
FELIPE NUÑEZ¹, (Member, IEEE), ALDO Z. CIPRIANO¹, (Senior Member, IEEE),
AND JUAN CARLOS SALAS⁴

¹Department of Electrical Engineering, Pontificia Universidad Católica de Chile, Santiago 7820436, Chile

²Department of Engineering Science, Universidad Andrés Bello, Santiago 7500971, Chile

³Department of Electrical Engineering, Universidad de Talca, Curicó 3340000, Chile

⁴Mining Engineering Department, Pontificia Universidad Católica de Chile, Santiago 7820436, Chile

Corresponding author: Jose Rodriguez (jose.rodriguez@unab.cl)

This work was supported in part by the Agencia Nacional de Investigación y Desarrollo (ANID) under Grant ANID PIA ACT192013. The work of Jose Rodriguez was supported by the ANID under Project FB0008 and Project 1170167. The work of Cristian Garcia was supported by the ANID/Fondo Nacional de Desarrollo Científico y Tecnológico (FONDECYT) through Initiation Research Project under Grant 11180235. The work of Freddy Flores-Bahamonde and Javier Pereda was supported by the Solar Energy Research Center (SERC) Chile under Grant Comisión Nacional de Investigación Científica y Tecnológica (CONICYT)/Fondo de Financiamiento de Centros de Investigación en Áreas Prioritarias (FONDAP)/15110019.

ABSTRACT The transition from fossil fuels to renewable energies as power sources in the heavy industries is one of the main climate change mitigation strategies. The carbon footprint in mining is related to its inherent extraction process, its high demand of electric power and water, and the use of diesel. However, considering its particular power requirements, the integration of microgrids throughout the whole control hierarchy of mining industry is an emergent topic. This paper provides an overview of the opportunities and challenges derived from the synergy between microgrids and the mining industry. Bidirectional and optimal power flow, as well as the integration of power quality have been identified as microgrid features that could potentially enhance mining processes. Recommendations pertaining to the technological transition and the improvement of energy issues in mining environments are also highlighted in this work.

INDEX TERMS Mining industry, microgrids, power quality, energy management system, renewable energies.

I. INTRODUCTION

Since 2015 the Paris agreement [1] has encouraged developed and developing nations to mitigate greenhouse gases (GHG) emissions, in order to keep the global average temperature two degrees above the pre-industrial levels. Consequently, in 2020, the World Economic Forum Annual Meeting recognized that net-zero emissions is not a simple goal for heavy industries, such as mining and energy generation, and therefore encouraged policy-makers to promote the insertion of renewable energy sources (RES) and to generate demand for low-carbon products [2]. To that end, initiatives such as those described in [3] and [4] have detailed the economic and environmental benefits and feasibility of using RES to supply mines by 2030.

The integration of RES in mines is not a novel topic; however, its expansion in the last five years has been notable.

The associate editor coordinating the review of this manuscript and approving it for publication was Ricardo de Castro.

In 2014, 62% of the global energy consumption in mining was from fossil fuels; in contrast, only 0.001% (less than 1000 MW) was from on-site RES [4]. According to [5] and [6], by 2019 there were nearly 80 mines around the world that reported RES integration, increasing the total capacity from 1066MW in 2015, to almost 5000MW in 2019. In addition, carbon mitigation policies implemented by several countries have impacted the operational expenditures of mines. For instance, the subsidies related to fossil fuels are projected to decrease from 70% of global energy sector subsidies in 2017 to 35% by 2030, while subsidies related to RES are set to increase from 26% to 41% during the same period [7].

A high penetration of RES in mines can lead to additional economic and social revenues benefits, even in post-closure scenarios. For instance, considering that 60% of mines have a life-cycle of less than 10 years [4], and the operation of RES-based generation plants can reach up to 20 years, surrounding communities can be supplied or complementary services can be offered to the utility grid once the mineral

exploitation is finished. Although a high penetration of RES in mines requires battery storage systems, which have a short life cycle (less than 3 years), the projected price by 2030 is \$70USD per kWh [8], which will improve the feasibility of their use in long-term projects. The aforementioned indicators regarding the economic impact of RES integration in mines are summarized in Fig. 1.

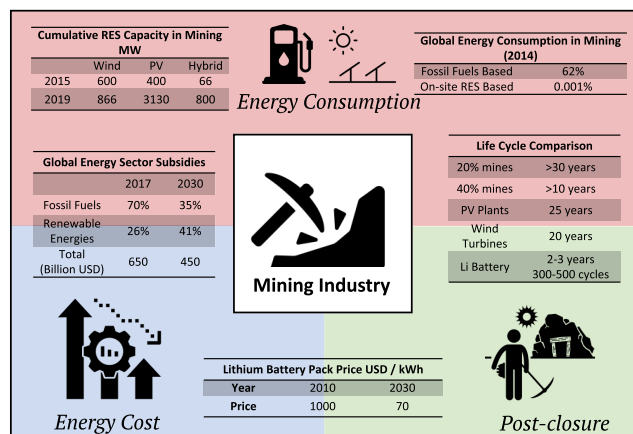

FIGURE 1. Comparative indicators pertaining to RES integration in mining. [4], [6]–[8].

Although some vendors provide solutions to connect this type of generation to industrial power networks, key pieces from the microgrid concept, such as distributed controllers at low levels of the control hierarchy and energy and demand management systems at the top, are not common in industrial environments. The application of the microgrid concept in mining requires an exploration of the whole process hierarchy to promote the optimal power usage, the improvement of power quality, and the advancement of power network reliability and resiliency.

From an electrical engineering perspective, the mining process can be understood as a set of heterogeneous electrical loads, mostly rotational machines, with different power features and priorities, that are connected to a local distribution network. However, elements such as mechanical gearboxes or nonlinear loads result in undesired effects such as voltage unbalances, harmonic pollution, poor power factor, and voltage sags or swells. Considering their nature, these phenomena should be mitigated quickly. To that end, the integration of control schemes such as model-based predictive control (MPC) in low-level local controllers (LC), as well as the insertion of power electronics drives, will facilitate the mitigation of these issues, improving the power quality and ensuring safe conditions.

At the top of the microgrid control hierarchy [9], energy management systems (EMSs) and demand-side management (DSM) are powerful tools for optimizing the power flow. The EMSs optimize the overall energy costs through short- and long-term economic dispatches [10], based on inputs such as aggregated load and generation profiles. Meanwhile, the DSM optimizes the load profile in accordance

with the energy available by managing process set points or re-scheduling flexible loads. However, the latter is not always feasible in mining; therefore, in this case the power profile is understood as a hard constraint, which must be satisfied in a business-as-usual approach [11].

The carbon footprint of mining activities is affected not only by the extraction process on a piece of land, but also by the high demand of electric power and water, the use of diesel, and the processing and disposal of wastes. Because mining is a non-avoidable economic activity, it is imperative to find techniques and technologies that enable its operations to become cleaner and safer. In this sense, the proper integration of microgrids in this heavy industry also includes information from auxiliary processes, promoting an optimal management not only of electric power, but also of water and land, reducing the overall fossil fuel consumption and mitigating its net carbon footprint.

This paper contributes to the field by providing an overview of the integration of microgrids into the mining industry. To this end, a selection of published works, related to mining processes, microgrids control, and associated topics, is reviewed. In order to construct the framework about microgrids integration in industrial processes, an analysis of their standardized control hierarchies is presented in Section II. Section III details each of the mining sub-processes from a mine-to-mill approach, highlighting their current particular requirements and how microgrid-compatible technologies can enhance their power systems. A high-level analysis of the mining-microgrid synergies is addressed in Section III; which considers potential integrations of EMS and DSM in this industry. Finally, Section V summarizes and discusses open challenges to be resolved in order to accomplish the integration of microgrids into the mining industry.

II. OVERVIEW OF INDUSTRIAL MICROGRIDS

A microgrid is defined as a set of loads and distributed generators (DGs), interconnected by transmission lines and protection devices, that acts as a single controllable entity [10]. The insertion of renewable energies into microgrids is usually done through power electronics converters, which allow the operation point to be manipulated according to the control strategy deployed. There are two modes of microgrid operation: grid-connected or isolated. Although several control schemes have been reported, all of them can be hierarchically classified according to the time span and the nature of the disturbances studied [12].

According to the IEEE Standard 2030.7 [10], at least three control levels have been defined for microgrid control, as shown in Fig. 2. These control levels, as well as particular subjects for microgrids integration in industrial environments, are explained below.

A. PRIMARY CONTROL LEVEL OF MICROGRIDS

The primary control level considers the fastest controllers in the microgrid, which act on the power electronics converters that are used as interfaces between the RES and the microgrid.

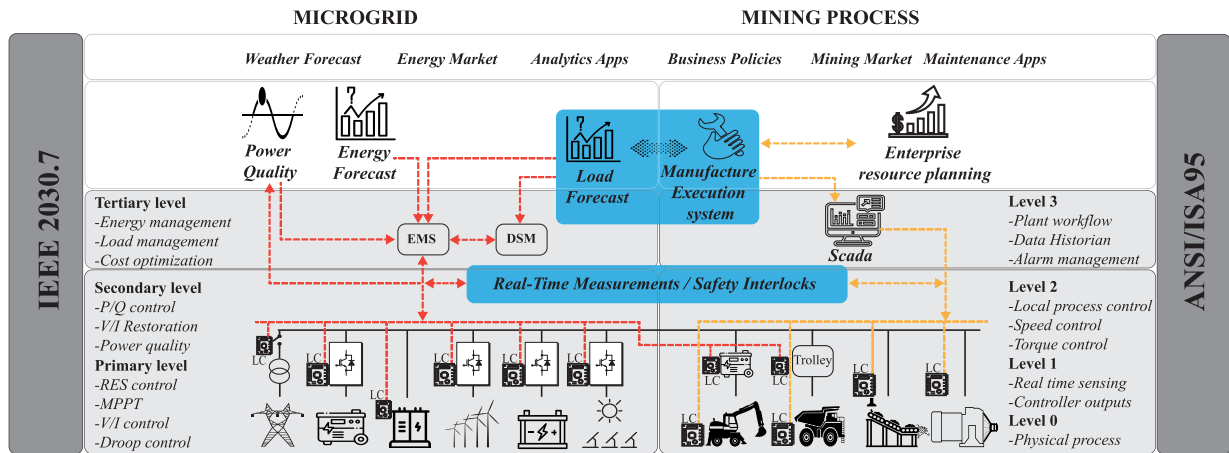

FIGURE 2. Interactions between IEEE 2030.7 and ANSI/ISA95 hierarchies.

Sampling periods of micro- or milliseconds are required at this level. One of the most commonly used interface to integrate RES with power grids is composed of two independent power converters with a common dc-link. In this configuration, the primary control loops in the generator-side converter pursue maximum power point tracking (MPPT) objectives to maximize the active power transferred through the dc-link to the grid-side converter.

The grid-side converter, also called active front end (AFE¹), can be configured as a voltage source converter (VSC) or a current source converter (CSC). Depending on the configuration selected, primary controllers include voltage, current, and frequency inner loops. Microgrids literature also states grid-forming and grid-following configurations for power electronics interfaces. Grid-forming converters establish an ac or dc voltage reference, which is used by the grid-following converters to compute their output power [14].

Primary controllers consider local variables and are typically decentralized. The outer primary controllers are called droop controllers. These deviate the frequency or voltage setpoints depending on the demand for active or reactive power, emulating the synchronous generator’s behavior and increasing the microgrid inertia [15].

B. SECONDARY CONTROL LEVEL OF MICROGRIDS

The secondary control level sets to microgrid-wide objectives. Although the main objective of this level is to restore frequency and voltage once the droop controllers have acted, additional control objectives related to power control [16], power quality [17] or economic policies [18] have been reported. For ac-dc hybrid microgrids, the power exchange between ac and dc networks is also included as a secondary control objective that acts on the interlinking converters [19].

¹For the rest of this paper the term AFE is used to describe dc-ac transistor-based converters connected to the power grid through a three-phase filter, independent of the topology used [13].

Secondary control schemes can be classified as centralized, decentralized, and distributed controllers [20], [21].

On one hand, centralized control schemes consist of a secondary controller that computes its action considering the information received from the distributed generators (DGs) on the microgrid. Although centralized controllers are suitable for small microgrids and they have the capability of including redundancy and fault tolerance, converging the microgrid information to only one point is a disadvantage of this type of controller. On the other hand, distributed controllers split their objectives into local subproblems, thus reducing the computational burden by computing the control action locally using information exchanged with neighboring DGs.

Because centralized and distributed secondary controllers require information about the whole microgrid, communication network disturbances such as long latencies and data dropouts should be taken into account when evaluating their performance [22]. Some techniques such as state machine-based controllers [23] and model-based predictive control contribute to relaxing the communication network requirements [24].

C. TERTIARY CONTROL LEVEL OF MICROGRIDS

Finally, tertiary controllers are usually based on optimization problems. Their objectives consider, among others, the optimal dispatch of RES (EMS approach), load displacement depending on the electrical generation (DSM approach), load forecasting, and the optimal use of energy storage systems (ESS). EMS and DSM thus belong to this level. To this end, the optimization problem requires inputs that are not only related to internal microgrid information (e.g. number of DGs, demanded power profiles, state of charge and health of ESS), but also external information such as the weather forecast and historical data from the energy market [25]. Because these tasks require considerable computational resources, the control period of tertiary controllers is between few minutes and one day.

Although the classical approach at this control level pursues an economical optimization, the multi-objective approach, which incorporates additional objectives such as carbon footprint mitigation or battery life optimization, is the currently considered cutting-edge. Because days-ahead models of generation and load profiles are required, the uncertainty of microgrid variables should be considered at this level to solve the dispatch problem [25]. In this way, information from DGs, controllable loads and smart meters in the microgrid, allows phenomenological and/or artificial intelligence-based structures to be taken into account in the construction of data-driven models.

For instance, in [26] a non-linear multi-objective optimization was implemented to minimize the green-house-gasses emissions as well as the microgrid operation and maintenance costs. In this case a phenomenological approach is used to model the costs related to each generator in the microgrid. A similar approach is used in [27]; however, the authors propose the use of fuzzy logic to forecast the generation capacity and the batteries schedule in the microgrid. In [28] fuzzy logic is also used to characterize the load uncertainty in the microgrid. As a common result of these works, the power peaks are reduced in the microgrids, and they all exhibit better battery life, and microgrid performance than that achieved with deterministic approaches.

D. MICROGRIDS INTEGRATION

Independent of the application, a hierarchical control structure is recommended for microgrids. However, the statement of control objectives and algorithms used on each level should consider features specific to the application. For instance, a microgrid designed to supply a rural community should incorporate dedicated tools and interfaces to ensure the project's social appropriation and self-management. In this case, a low-voltage network is built to support local productive processes (e.g. farming), and also to supply family households and community buildings (e.g. schools or medical centers), implying a significant amount of single-phase flexible loads [29], [30].

In contrast, a microgrid for an industrial application, such as mining, will require not only low but also medium and high voltage distribution networks, as well as the integration of three-phase and dc loads. Moreover, the power demand is not as flexible as it is for rural applications (except for batch processes). Therefore, it is not always feasible to manage or schedule load profiles using DSM applications.

ANSI/ISA Standard 95 frames industrial processes in a five-level hierarchy. Levels 0 and 1 refer to the physical processes, together with their sensing and control signals. Level 2 includes the process control and monitoring. Level 3 states the process workflow, while level 4 sets business-related policies and activities. Therefore, industrial applications of microgrids should establish interactions between the IEEE 2030.7 and ANSI/ISA 95 hierarchies to optimize the power consumption and to ensure proper process operation and plant safety. Considering that all these applications have particular

features and structures, Fig. 2 aims to illustrate the aforementioned interactions.

Secondary control level of microgrids and the ANSI/ISA control level 2 exchange real time measurements or estimated variables such as voltage, current, active/reactive power, phase angle or frequency. These signals are required in order to achieve microgrid objectives such as frequency or voltage regulation, process objectives such as speed or torque control or to enable/disable safety interlocks. However, a more complex interaction is stated between ANSI/ISA level 3 and tertiary control of microgrids. At this level, historical data from SCADA platforms, are used to build load profiles required by the EMS and DSM, whereas the latter sends to SCADA useful information required to state the plant workflow. Because a real-time operation is not required at this level, tasks such as multi-platform information exchange, profile building, forecasting, or fault analysis/prognosis can run in cloud-based applications, enabling the use of external information about markets, maintenance, stocks, or weather [31].

Although many of the reported microgrid applications concern research testbeds or rural electrification [20], [32], [33], the academic community is currently discussing not only RES insertion to supply whole plants such as mines (EMS approach), but also sub-process optimization according to the energy available in off-grid scenarios (DSM approach) [11]. In contrast, there are not detailed reports of microgrids in heavy industries. Despite this, suppliers such as ABB and Siemens have developed software and hardware platforms to promote the use of microgrids in heavy industries [34], [35]. In this regard, many of these industries have a non-flexible, uninterrupted workflow, and the proposed solutions are focused on EMS rather than DSM platforms. For such reasons, academic works, as well as industrial solutions for specific mining sub-processes are presented in Section III, while a comprehensive microgrids-in-mining approach is discussed in Section IV.

III. MINING OVERVIEW

Mining is a complex process composed of multiple interactions among sub-processes and supplies such as electric power, water, and diesel. As shown in Fig. 3, in a mine-to-mill concept, the mining process can be split into ore extraction, materials handling and mineral processing [36]. Although the technology used in these processes can change depending on the mine type (underground, off-shore or surface), there are common auxiliary processes used to provide the utilities as required by specific tasks (e.g. water desalination or backup power generation from diesel engines) or to sustain the mine operation (e.g. ventilation or dewatering).

The total power demanded by mining, without considering ancillary processes, comes mainly from extraction (11%), handling (21%), and ore processing (44%) [36]. All technologies and operational procedures involved in mining must consider safety concerns, e.g. area classification (ATEX directives), in order to state safety interlocks in process controllers or grounding requirements for electrical devices.

TABLE 1. Mining processes and potential microgrids applications.

Main Process	References	Sub-process	Features	Power Rating	Potential Microgrid Applications
Extraction	[37] [38] [39] [40] [42]	Drilling	-Non-linear and cyclical load (hours) -Produces harmonic pollution -Requires mobile substations	-Drill 0.7MW -Shovels 1.5-5MW -Dragline 24MW -Submarine mining vehicle 2MW	-Fast regenerative energy management -AFE + power quality applications -Control strategies without electrical network model -Internal microgrids -Energy storage
		Digging	-Diesel or electrical supply -Non-linear and cyclical load (mins) -AC machines used in shovels		
Handling	[40] [43] [44] [45] [46] [47] [48] [49] [50]	Belt Conveyors	-Covers dozens of km -Multi-motor master-slave arrays -Requires uniform torque distribution -Gearless synchronous machines are used -Regenerative power is burned	-Belt drive 0.5-1.05MW -Hauling truck 2-4.8MW	-Power profile can be characterized -AFE + power quality applications -Hybrid microgrid application -Regenerative power included in EMS
		Hauling Trucks	-Better flexibility than belt conveyors -Diesel and/or electrical supply -Electrical supply uses dc distribution network -Bidirectional ac drives are required (boosting & braking) -Regenerative power is burned		
Mineral Processing	[51] [52] [40] [53] [54] [55] [56] [57] [58] [59] [60]	Grinding Circuit	-Primary grinding by SAG or HPGR mills -SAG mill efficiency ≈ 2% -High starting torque requirements -Power consumption depends on ore hardness and ore position -Cycloconverters induce harmonic pollution as function of machine speed	-SAG mill 10-30MW -Ball mill 5-20MW -Rolling mill 7MW -High pressure grinding roll 2MW	-Power quality management using active filtering -DSM using stockpiles and ore mixing -Using complementary power quality objectives in machine control should be studied

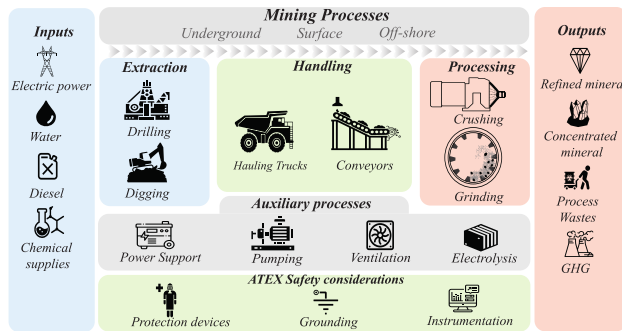

FIGURE 3. Mining process overview.

Next, the mining processes, as well as the distribution networks used in mines, will be described individually; as summarized in Table 1. Power quality issues and opportunities that stem from a microgrids approach are also discussed.

A. ORE EXTRACTION

The ore extraction process demands around 25% of total power in mining and includes tasks such as drilling (5%), blasting(2%), digging (6%) as well as auxiliary tasks such as ventilation (10%) and dewatering (2%) [36]. Machinery used in this process, such as drills, shovels, draglines, and longwall mining machines are usually powered by a set of ac or dc machines supplied by a diesel or electrical generator. In the latter case, mobile sub-stations are used to plug the machinery into the distribution system, implying that the

electrical network changes its topology according to the mine development [37], [38].

The load profile of this type of machinery is non-linear and cyclical; it must account for minutes-long cycles for shovels and hours-long for drills, which leads to high power over- and undershoots (regenerative power) [39]. The power profile depends on the ore type and other factors, such as the drills rate of penetration or the shovels load, implying challenges related to speed and local voltage regulation. Although there have been efforts to improve the energy efficiency of drills and shovels [40], these processes deteriorate the power quality in mining distribution networks, inducing harmonic pollution and voltage sags and swells [41]. It is a well known fact that the use of power electronics converters, inside or outside of mining machinery, e.g. as active front end (AFE) or speed drives, helps to mitigate these power quality issues [37], [38], [41]. however, this technology also poses new problems from the microgrid point of view, as shown in Fig. 4.

For the inside-of-machinery case, [37] opens the discussion about internal microgrids in mobile mining machinery. In this approach the internal dc machines are plugged, through power electronics interfaces, to a common bus, which is supplied from the distribution system. In addition, [42] compares the features of different types of ESS used in the inside-of-machinery approach. Although primary and secondary microgrid controllers that integrate ESS, harmonic pollution or unbalances have been documented [17], [61], strategies for energy management when regenerative power is available, to the best of our knowledge, have not been studied. As was shown in [39], regenerated power in a shovel

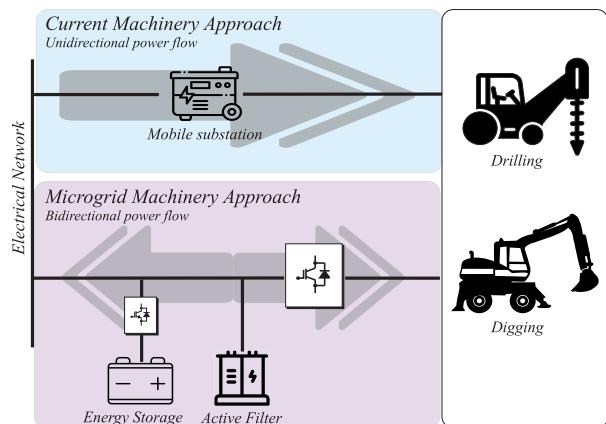

FIGURE 4. Ore extraction process.

machine can reach 2MW per cycle and, in addition to the high uncertainty of the load profile, make the use of typical EMS strategies unfeasible. Therefore, secondary microgrid controllers that include these concerns should be explored by, for instance, using model-based predictive control (MPC) or data-driven control techniques.

On the other hand, because the power flow of the extraction process is subject to mobile machinery relocation and availability, it must use active/reactive power control strategies that are independent of the electrical network model. This outside-of-machinery approach is addressed in the microgrid context, by using secondary controllers based on the proportional-integral (PI) algorithm [16]. However, applications using constrained-MPC have shown promising results including both typical secondary control objectives and operational constraints [24]. By using MPC, it is possible to explore applications of hybrid ac-dc microgrids in mines, including power quality indices in the secondary control level, or active power filter management strategies and safety indexes at the tertiary level.

B. MATERIALS HANDLING

Once the ore is extracted from the earth, it is carried out to the beneficiation and processing facilities either by hauling trucks or conveyor belt systems. Although there are several cost-benefit studies for both systems [43], the decision as to which is used is based on the mine features and its mine plan. The power consumption of such technologies is governed by the load weight and the path inclination. For instance, in open pit mines the ore transportation outside of the pit using hauling trucks can represent up to 40% of the mine’s total diesel consumption [40]. Therefore, improving the efficiency of these systems by reducing mechanical pieces and using latest-generation electrical drives may allow a better torque and speed control or even energy recovery in downhill paths. The approach that is currently in use and the proposed microgrid approach, which supply handling systems via a distribution network, are summarized in Fig. 5 and detailed below.

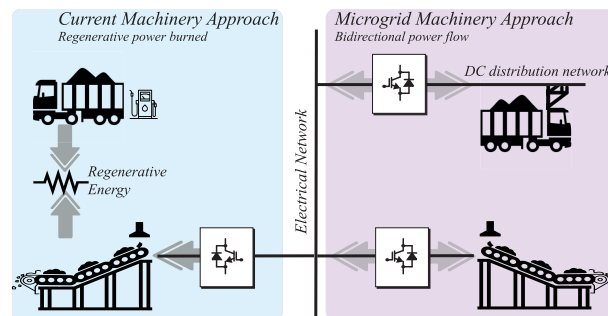

FIGURE 5. Ore handling process.

Conveyor belt systems can cover kilometers using multi-motor arrays that are connected to a medium voltage (MV) ac or dc distribution network through power electronics converters. In this case, a master-slave control scheme is used to pursue a uniform torque distribution over the slaves. When this target is not achievable, the master reduces the speed reference in order to improve the distribution of the ore on the belt [44]. Gearless synchronous machines, which allow torque control at low frequencies, are used in this type of system. When deceleration or braking is required, or in downhill paths, regenerative energy can be transferred from the electrical machine to the dc-link, in which case a chopper array is used to burn it in a resistor bank. However, when the regenerative power is significant, it can be re-injected into the distribution network by using a controlled bidirectional AFE converter instead of an uncontrolled rectifier between the ac distribution network and the dc-link [45].

Hauling trucks have better availability and flexibility features than conveyor belt systems because it is possible to adjust the truck fleet to changes in production rates or to replace trucks if they break down [40]; however, a fleet composed of diesel-based trucks can be an expensive solution. Although trolley systems were used in the past, new developments in power electronics and electrical machines have allowed cooperative research among suppliers, e.g Siemens/Hitachi and ABB/Caterpillar, that aims to improve the feasibility of using diesel-electrical hybrid hauling trucks [46]–[48].

Hybrid trucks use pantographs to self-connect to the overhead dc lines, allowing them to go faster and reducing their fuel consumption [46]. Typically, a parallel connection is stated between the dc lines and the internal dc-link at 2.6kV. However, some mines with lower dc voltage in the distribution network require a series connection between the wires and the internal on-board power supply. Despite the power generation system used (diesel or electrical), hauling trucks traction systems are boosted by bidirectional ac drives that allow torque control and efficient braking. As in conveyor belt systems, in braking situations or downhill paths, electrical machines regenerate power which is burned by a resistor bank connected to the dc-link [49].

Conveyor belts and trolley-assisted trucks represent an opportunity to include ore handling in the electrical load of

the MV distribution network. These systems operate uninterruptedly, can cover kilometers over constant paths, and carry a predefined amount of ore. Therefore, their bidirectional power profile can be well characterized in order to harness regenerative power instead of burning it [50].

From the microgrids perspective, the bi-directional power management is usual for both ESS (e.g. battery-based energy storage systems (BESS)) to support the load when the generation capacity is not sufficient, and for interlinking converters to manage the power transferred between ac and dc networks in a hybrid microgrid. However, the case of a bidirectional load has not been yet explored. In fact, the use of BESS close to hauling systems is not always feasible. Therefore, the development of primary and secondary control schemes to handle regenerative power caused by downhill hauling or braking without affecting torque/speed control or deteriorating the power quality, and the incorporation of regenerative power features into the EMS problem, are open challenges.

C. MINERAL PROCESSING

Mineral processing includes comminution and recovering stages, like flotation. As shown in Fig. 6, at the concentration plant, the ore is processed to increase the grade of valuable elements in crushing, grinding and concentration stages. Semi-autogenous grinding (SAG) mills and high-pressure grinding rolls (HPGR) are the most commonly used technologies for primary grinding. A classification circuit using hydrocyclones moves the mineral that does not satisfy the

desired fineness to a second grinding stage where ball or rod mills are used. Once the targeted size distribution is achieved, a final concentration stage is carried out, usually by flotation [51].

Grinding uses around 40% of the total power in mining, while crushing or separation processes consume 4% of the total power [36]. In addition, SAG mills' energy efficiency does not surpass 2%. Therefore, any improvement in energy efficiency will allow them to increase or preserve their throughput, or to reduce the power consumption if the ore conditions are maintained. HPGR applications have reported energy savings of around 20% and better throughput than SAG mills [40], [52]. Because of its significant power consumption, the scope of this section is focused on the grinding process and how it could potentially be improved by the microgrids concept.

Variable speed is mandatory in the grinding process. Although this requirement can be met using gearboxes, the combination of synchronous machines and power electronics converters is preferred [53], due to its higher starting torque (120% is usually required [54]), at low frequencies. In addition, a gearless mill drive requires less maintenance than a mechanical gearbox and allows a controlled roll-back and positioning. In a SAG mill, the rotor poles are mounted on the external surface of the mill drum, whereas the stator is assembled around the poles array considering 14-16 mm of airgap [51]. HPGR mills use two reverse rotation rollers, one of which is fixed. The movable roller provides the compression force required to fracture the ore and forces the material to be fed through a reduced space (operational gap) [55].

For both SAG and HPGR mills, cycloconverters are the most used interface between the synchronous machine and its control stage, despite its low power factor. The harmonic pollution produced by cycloconverters depends on the machine speed, and the dead time required as a transition between positive and negative bridges commutation can induct torque oscillations [56]. Consequently, converter topologies such as modular converters and neutral point clamped converters (NPC) [62], [63] have been introduced for grinding applications.

Power consumption of electrical machines used in grinding is not forecastable because it depends on the ore hardness and the load position [64]. In addition, by its self-operation, grinding machinery is subject to deformation. In SAG mills in the air gap between rotor and stator is affected, whereas for HPGR mills is the operational gap; in both cases, the deformations affect the performance of the synchronous machine. The "frozen charge" phenomena, in which the ore is packed after a mill's shut down period, is a remarkable concern for SAG mills because it can destroy the mill when it is restarted [53]. In this case a "frozen charge protection", which involves shaking the mill's drum, can be implemented by controlling the speed and acceleration [57].

As in the cases of conveyor belts conveyors and shovels, the use of new topologies of power electronics converters

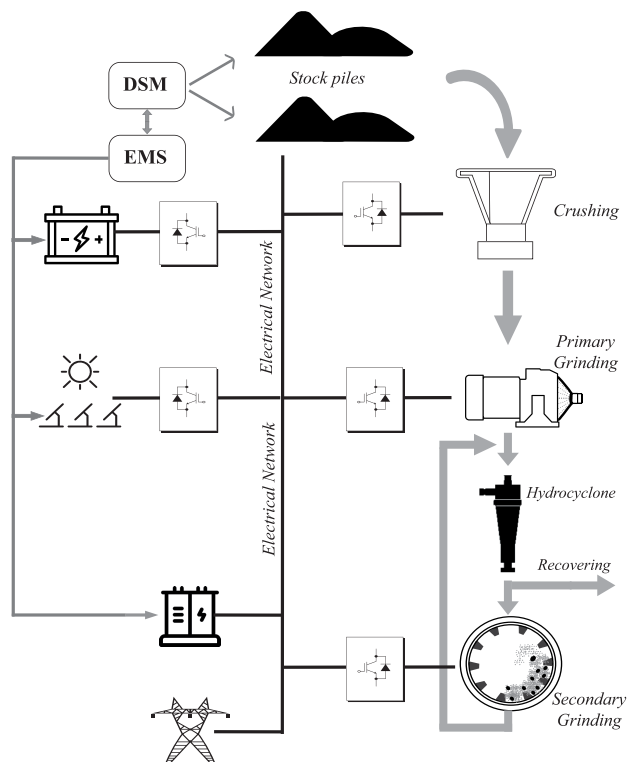

FIGURE 6. Comminution process.

TABLE 2. Voltage rates in mining applications.

	Voltage [V]									
	0-50	51-120	121-240	241-600	601-660	661-1k	1k-1.5k	1.5k-2.4k	2.4k-69k	69k-230k
IEEE 141 std	LV					MV				HV
AS/NZS 4871.1:2012 [ac]	ELV	LV					HV			
AS/NZS 4871.1:2012 [dc]	ELV	LV					HV			
Mining Enforcement Safety Administration (MESA-US)	LV					MV	HV			
Applications	24Vdc -Instrum. & control devices		230V -Underground sec. distribution	500V -Underground sec. distribution		690V -Conveyor belt 900Vdc -Hoist 1kV -Underground sec. distribution	1400Vdc -Hauling trucks	1800Vdc -Hauling trucks	3-5kV -dc deep-sea distribution netw. 3.3kV -Underground sec. distribution 6kV -Deep-sea distribution 6kV -Deep-sea mining vehicle 6kV -Underground primary distribut. 7.2kV -Shovels and drills 11kV -Distribution netw. 13.2kV -Distribution network 13.8kV -Distribution netw. 22kV Distribution network 22kVdc -dragline 23kV -Distribution network 33kV -Distribution network 66kV -Distribution network	230kV -Utility distribution

helps to mitigate harmonic pollution and to use novel control schemes to improve the overall drive performance [54]. Despite the power quality concerns and the disturbances in the distribution network caused by cycloconverters, research is currently exploring control techniques to improve the overall performance of the grinding circuit. In this sense, multi-variable control schemes have shown better properties than classical PI controllers.

In [58], an optimal controller is proposed to reduce the cost of comminution and separation processes. In this case, an economical model for each process is stated, considering variables such as the water flowrate, ore feed-rate and the mill rotational speed. In [59], an MPC is proposed to reduce the total energy consumption in the grinding process; it does so by using the same optimization problem to manipulate the water added to the process and the feed-rates of the cyclone and the mills. Promoting the use of RES in mining, [60] proposes a DSM to modulate the ore that is fed into the grinding circuit according to the energy available and the ore hardness grade. Although energy and economical savings are accomplished in the latter work, several changes in the process, such as ore classification using two stockpiles, are required to derive forecasting models of ore properties.

The inclusion of microgrids in the mining industry aims, indirectly, to reduce the footprint of the grinding process, by including RES into the distribution networks used in mines. Regenerative power does not have a significant potential in this process, and the inclusion of power quality objectives in the control scheme of power electronics converters should be studied. In the grinding process, multiple interactions among flowrate, feed-rate and level control loops are required. Therefore, from a microgrids point of view, sampling period and settling time requirements can limit the use of secondary controllers that are currently used to pursue power quality objectives.

Considering that the requirements stated in [60] may be feasible in new mines, it is possible to state that

DSM represents the most suitable opportunity for incorporating the comminution process into the microgrid hierarchy. However, as will be presented in Section IV, DSM implementation implies a multidisciplinary team and a long-term commitment.

D. POWER DISTRIBUTION NETWORKS IN MINING

Energy consumption in mining applications is highly variable and depends on several factors such as the type of mineral, its depth, and the mining plan. According to [36] and [3], the typical power demanded by a calcined clay mine is around 1.43 kWh/ton, whereas a copper mine consumes 2.5 MWh/ton. These values increase in line with the mine growth and, therefore, the internal distribution network should be adaptable in order to include new loads and allow changes in the loads placement. By studying the architecture of their electrical systems, high (HV), medium (MV), low voltage (LV) and extra-low voltage (ELV) distribution networks can be identified; these categories are rated by different standards, as shown in Table 2. LV networks supply low-power support tasks such as illumination, information technologies, and control and instrumentation devices whereas MV and HV supply heavy processes such as drilling, crushing or grinding [41].

There is no consensus about using ac, dc or hybrid distribution networks in mining. However, requirements such as high short-circuit capacity, generation support, or protection scheme, along with power quality issues, e.g. voltage regulation, or harmonic pollution, should be considered for each application. Distribution networks used in underground and deep-sea mines usually have a radial-based topology while open pit mines have a ring-based topology [65]. In any topology, the distribution network varies depending on the machinery required (e.g. shovels and drills), which in turn affects the grounding system as well as the voltage regulation capability.

High-resistance grounding systems are used in mining applications, due to their ability to limit the current between the neutral and the ground nodes (10A according to IEEE 142 standard) in case of failure; they thus ensure the safety conditions of the workers in the area [66]. However, topology changes imply changes in the system distributed reactances (inductive and capacitive). Therefore, the required current limitation cannot be ensured. As grounding depends on physical parameters, it is not possible to identify improvements from the microgrids perspective. Even so, the evolution of solid-state protection devices will lead to improved energy management and, faster failure isolation.

Voltage sags and swells are typical in mining distribution networks. Although the IEEE Standard 141 permits variations of $\pm 5\%$ around the nominal value, greater changes imply voltage regulation issues. Voltage sags occur when the load current increases due to devices such as high-power motors being turned on; they can also be caused by transformers inrush currents, short circuit failures, or torque changes in drills, shovels or mills. According to [41], it is possible to mitigate voltage sags by using AFE converters connected to the ac distribution network. This is achieved by using a dc-link between the AFE and the machine-side converter to compensate for fast disturbances by using the energy stored in the dc-link. Some variations of this scheme have been proposed, for instance, stating long dc links to supply undersea loads [67], open-pit dc machinery [37], or even additional dc distribution networks [68].

Likewise, new topologies of power electronics converters such as modular multilevel converters (M2C) [69] and modular matrix multilevel converters (M3C) [70], used as dc-ac or ac-ac interfaces, are displacing diode and thyristor-based ones. Although the control scheme required in these new topologies is more complex than that the required in typical six power switch converters, their capability to manage high power and to improve harmonic profiles make them suitable solutions in mining.

Voltage swells in mining distribution networks are usually a consequence of resonance between substations inductance and long-lines capacitance, which produces damage and degradation in vacuum-isolated devices and auxiliary power supplies. This can be mitigated by using surge arresters and/or by including AFE converters close to the machinery. However, harmonic pollution in the distribution network can excite the system resonance frequencies, producing over-voltages. Therefore, active or passive filters should be included [38].

Active and passive filters have been proposed as a solution to maintain the power factor close to one, compensating reactive power and mitigating the harmonic pollution produced by network imbalances, non-linear loads and power electronics converters [71], [72]. Regarding the changes of the distribution network topology and the reactive power requirements, high-power filters placed at the network base-line are more suitable than individual filters at the terminals of each converter [71]. The wide use of motors in mining, especially in

drills, shovels, conveyor belts and mills, as shown in Fig. 7, causes sub-harmonics and inter-harmonics in the network, which are produced by fast torque disturbances due to the properties of the excavated-soil and ore [65].

Although passive filters such as bandpass and C-type filters are economically more feasible than active filters, the latter have shown capabilities that are not afforded by passive filters such as voltage and current imbalance compensation or stepless control [73]. On one hand, Passive C-type filters are proposed as a proper solution in mining distribution systems due to their lower inrush current, lower power losses and an attenuation factor similar than a second-order highpass filter [71]. However, as a passive filter, it is susceptible to detuning caused by the degradation of components degradation or changes in the mine operation. On the other hand, active filters are more versatile than their passive counterparts due to their capability to cancel the effects of non-linear loads and improve the power quality in LV and MV networks. However, they are expensive when high power is required at high voltages. Therefore, it is not feasible to use them in heavy industries.

To address the aforementioned drawbacks, hybrid filters have been reported; they combine passive filters tuned to the dominant harmonic with active filters to mitigate additional harmonic pollution. This hybrid approach is capable of incorporating control objectives related not only to harmonic compensation, but also to reactive power control at the nominal frequency, imbalances compensation, and voltage control (sags and swells) [73]. In power systems literature, these types of devices are also referred to as flexible ac transmission systems (FACTS), which include static compensators (STATCOM), dynamic voltage restorers (DVR), and unified power quality conditioners (UPQC), among others [74]. Although it is not possible to attend all of these control objectives by using only one filter in the distribution network, the potential inclusion of these devices in the control hierarchy of industrial microgrids will allow cooperative schemes between filters and RES, thus improving the overall power quality.

In [75] and [76] active filter capabilities are added to the control schemes of a photovoltaic plant and a wind turbine, respectively, and could potentially be used in the microgrids context. In [75], a series and a shunt active filters are used to compensate for utility voltage sags/swells and, at the same time, provide active power from a photovoltaic plant connected to the dc-link. In this case, the reference signals for both power converters are computed by combining maximum power point tracking, dc-link control and output ac voltage control tasks. Similarly, [76] proposes a scheme to control a DFIG-based wind turbine connected to the utility via two power converters in a back-to-back configuration. However, this case uses harmonics and power factor compensation, instead of ac voltage regulation as its control objectives. This scheme uses the grid-side converter to mitigate harmonics and the rotor-side converter to control the turbine.

The massive inclusion of power electronics converters for load control in mining sub-processes has led to improvements

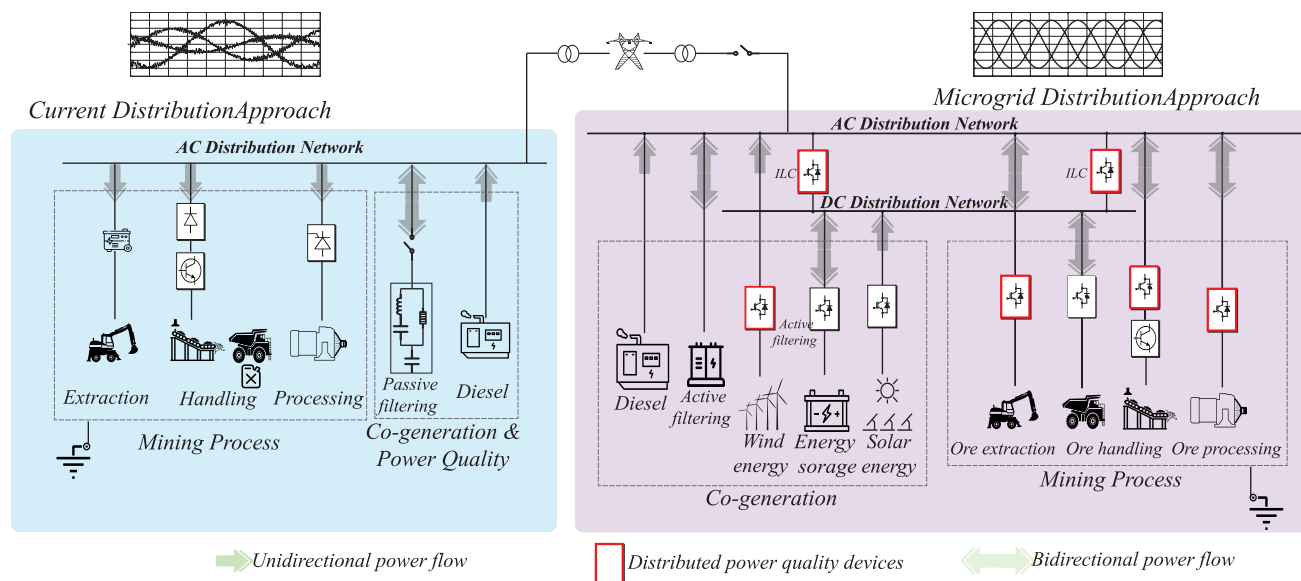

FIGURE 7. Power distribution networks in mining.

in their power efficiency. However, in several cases a coexistence between old and new technologies is required. Power quality issues produced by old devices and machinery will therefore be present in the distribution network. As previously discussed, due the constant changes in the network topology, the use of passive filters is not an efficient approach to resolving these issues in mines whereas active filtering, which requires power electronics converters, can be included as an additional control objective in AFE. In this context, as shown in Fig. 7, a microgrid approach will require a power quality management, which can be achieved either by including dedicated active filters or/and by adding related control objectives in the RES. Additionally, it is possible to state cooperative schemes in which distributed secondary controllers include a global power quality objective. Considering that power quality management is not an easy accomplishment, MPC is a promising scheme for stating optimal operating conditions, including power quality and feasibility constraints, without sacrificing the reliability of the distribution network.

The ac-dc hybrid microgrid concept [19] can also be applied in the mining context, for instance, in undersea applications or trolley-assisted handling processes, as shown in Section III. In this type of microgrid, at least one interlinking converter (ILC) is used as an interface between ac and dc microgrids. There are two approaches for power flow policies in hybrid microgrids [19], [77]; the first is used if a constant power flow through the ILC is required while the second is implemented in cases in which the ac or dc microgrid capacity may be surpassed. In both cases, it is also possible to include power quality control objectives on the ac-side of the ILC.

Although some microgrid opportunities explored in this section, require proper management from the tertiary control level of microgrids, e.g. regenerative power integration or DSM applications in the comminution circuit, the integration

of power quality objectives at this control level is not an obvious step. The integration of EMS and DSM in the mining industry will be explained in Section IV.

IV. MICROGRIDS APPLICATIONS IN MINING

There are several studies and reports about the economical savings achieved when RES are included in the mining process [78]–[80], where additional objectives such as carbon emissions mitigation [81] or auxiliary processes such as water desalination [82], are included. As was shown in Section II and Section III, successful integration of microgrids in the mining industry requires not only the integration of RES, but also changes throughout the whole mine structure, promoting an “optimization of the whole” instead of an “optimization of the parts” approach [52]. The former approach facilitates the interaction between EMS and DSM to maximize, for instance, the grinding circuit throughput, while minimizing the economic cost. However, this sort of goal requires a unified and multidisciplinary perspective of the mining operation, which is built by integrating geology, mining processes, maintenance, environment, safety and logistics information, into a long-term strategy.

Although detailed engineering information is not part of the public domain, technical reports and papers, such as [4] and [5], have summarized information from several cases. Table 3 presents an information survey of the reported cases. However, based on the information available, it is not possible to determine whether the microgrid concept was used. An additional reference related to this topic is [52], where the experiences of projects from Australia (BHP-Billiton and Rio Tinto) and Chile (Kairos) are summarized. In these cases, the optimization process achieves a mill throughput increase of up to 30% and a 30% decrease in kWh/ton. These cases can be considered as DSM applications because the process

TABLE 3. Cases of RES integration in mining.

Country	Mining Company	Mine	Commodity	RES Capacity	RES Type	Savings	Ref
Chile	Antofagasta and Barrick Gold	Zaldivar	Copper	550GWh/year	PV+Wind+Hydro	350kton CO ₂ e	[4]
Suriname	Iamgold and Rosebel Gold Mines	-	Gold	5MW	PV	Opex reduction from US\$0.12 to US\$0.01 per kWh	[4]
Australia	Rio Tinto	-	Bauxite	6.7MW	PV+BESS	Up to 2.3 M liters of diesel annually	[4]
Burkina Faso	Iamgold	Essakane	Gold	15MW	Solar	6M liters of diesel annually and 18.5 kton CO ₂ e	[4]
Canada	Goldcorp	The Borden	Gold	-	BESS	C\$9 M, 2M liters of diesel and 1M liter of propane per year	[4]
Chile	CODELCO	Chuquicamata	Copper	1MW	PV	2.69 GWh from RES per year	[5]
South Africa	CRONIMET	Thaba	Chromium	1MW	PV	1.8 GWh from RES per year	[5]
Canada	Rio Tinto	Diavik	Diamond	2.3MW	Wind	10% reduction of diesel consumption and 6% of CO ₂ e	[5]

is modulated by a global objective (e.g. best market price) without considering the integration of RES. Techniques such as smart ore tracking, optical fragmentation analysis, MPC to optimize fuel consumption and combustion process in kilns, as well as the integration of different historical databases and the inclusion of multidisciplinary key performance indicators (KPIs) were developed in some of the reported projects.

The EMS applications are as important as the DSM ones. In EMS, the dispatch of RES is optimized according to the power generation capacity whereas the demanded power is considered as a hard constraint. In EMS the generation and demanded power should be considered as uncertain variables. Though it is possible to state power profiles, concerns such as cloudiness, changes in wind speed and direction, or rock hardness lead to power disturbances which should be managed properly. Although several EMS schemes have been reported for LV microgrids [25], to the best of our knowledge, reports on heavy industry applications are limited.

In [83], an EMS is proposed to promote the power self-consumption in mines, which are located in countries that forbid injecting the power into the utility network. Although the proposed formulation accounts for multiple generators and multiple loads, a single-node microgrid representation is assumed in the case study, which states the overall power demanded by the mine as the load and uses a wind turbine as a generator. The cost function used in the optimization problem weights the supplied power (by RES and utility) and the power losses as well as the non-supplied power when the generation capacity overpass the power demanded. Power balance and power capacity constraints are used to ensure solution feasibility while the uncertainty is characterized by adding white noise to a spectral representation of power profiles. The results of this case study show that, in comparison with the ideal case, the power demanded from the utility is slightly higher when uncertainty is included in the optimization problem. However, this increase allows a better dynamic response to wind variability and load disturbances.

In contrast to the academic papers, [5] and [84] summarize technical reports about RES insertion in mining operations. Although the engineering details are not available, the reliability requirements of this type of project involve using industrial solutions from vendors such as ABB or Siemens. Vendors solutions such as those reported in [34], [35] are based on EMS and are developed to optimize the power

generation and quality in industrial environments; They do so by using plant-based and/or cloud-based services that integrate power data from local process, historical logs and on-line analytics systems to support decision-making processes.

The integration of process and power data, helps not only to improve EMS and DSM operations, but also to build disconnection and re-connection protocols, including safety concerns, thus harnessing the microgrid's flexibility to improve the operational reliability and resilience of the mine. As it is presented in [85], [86] and [87], the integration of distributed generation, distributed control systems and, mobile energy storage systems enable the power systems to respond properly when disturbed by failures, topology changes and/or external emergencies. For instance, decision-making systems should prioritize auxiliary processes such as ventilation for underground mines, or support black-start sequences according to the state of safety interlocks from each sub-process thereby minimizing the break period after the system shutdown without sacrificing its integrity [88].

Even though auxiliary processes such as water primary pumping and desalination, ventilation, and refrigeration do not represent the major power consumption in mining, it is possible to include some of them as flexible loads in DSM optimization problems. While the water demand in mining processes is continuous, it is possible to develop control strategies to relax upstream water requirements by, for instance, pumping, desalinating, and storing water when the RES-based generation capacity is high. In this sense, [89] identifies additional ancillary processes that can be aligned with EMS and DSM schemes in mining. Although implementing this type of projects will not represent substantial savings, the energy optimization and footprint mitigation in ancillary processes will open the door to pursue optimization milestones and microgrid integration in mines.

V. OPPORTUNITIES AND RECOMMENDATIONS

This paper has examined the mining process and microgrid control structures and aims to advance the academic discussion by exposing current issues and challenges and proposing research opportunities that could contribute to the integration of microgrids in this heavy industry. As it was presented in Section II, this integration implies challenges throughout the control hierarchies of both mining and microgrids, especially

because of the high reliability and safety requirements, which are stricter than those of microgrids applications in communities. The most noteworthy concerns, highlighted in Section III and Section IV, are related to power quality issues and regenerative power management in low control levels. Meanwhile, the integration of multidisciplinary information, which can be used to state optimization objectives and support decision making, is the main challenge that drives R&D opportunities at the top of the control hierarchy.

Power quality issues such as harmonic pollution, voltage regulation, power factor compensation and resonance are present in ore extraction, ore handling and comminution processes. The use of power electronics-based drives and synchronous machines has improved the efficiency of shovels, drills, conveyor belts and mills. However, ac-ac converter topologies such as cycloconverters cause significant harmonic pollution and a low power factor, increasing the risk of resonance and voltage collapse in the distribution network. Therefore, ac-dc-ac schemes, in which AFE converters are used instead of diode-based rectifiers, have been suggested. Passive filters used in other industries to mitigate harmonic pollution and to compensate for the power factor, are not always feasible in mining because the distribution network changes as the mine develops and/or the machinery placement is adjusted. In such cases, using active filters is a suitable solution. However, from the microgrids point of view, both the inclusion of complementary and cooperative control objectives in power electronic interfaces used by RES and mining machinery, and improvements in the overall power quality of the distribution network remain open problems.

Regenerative power is also present in mining operations but it is not harnessed. Although power profiles of conveyor belts and hauling trucks are more forecastable than those of drills and shovels, when the ore is transported through downhill paths, resistor banks are used to burn the generated power. Therefore, bidirectional power electronics interfaces and proper control strategies should be developed to store the power surplus or inject it into the distribution network.

In this sense, questions such as: how fast should secondary controllers act when regenerative power and harmonic compensation are considered?, which is the most suitable ESS in these type applications?, how should the harnessed regenerative power be included in EMS?, among others, still need to be addressed. To this end, the expertise from multidisciplinary teams is required both to build theoretical answers and to achieve solutions that can be deployed in mines by using industrial platforms. Therefore, tools such as MPC, data-driven modeling, advanced metering devices, and new communication technologies should be explored to achieve the technological transition required in mining.

MPC is a powerful tool that can include both harmonic pollution compensation and regenerative power harnessing objectives, at the secondary control level of microgrids. Including equality and inequality constraints in the optimization problem allows this type of controller to directly manage feasibility concerns such as network power balance,

performance indices that reflect the power quality, and/or rate-of-change bounding of controlled variables in transient states. As described in Section II, applications of secondary controllers that use MPC have been reported; they use complex prediction models to achieve the aforementioned control objectives. However, they can imply a high computational burden, which is not compatible with the sampling period required at this control level.

EMS is mandatory for microgrids integration in mining. This tertiary controller states the optimal dispatch of DGs connected to the microgrid by considering the power demanded and generation forecasts. Although there are several applications of EMS in microgrids, their uses in industrial environments, such as mining, have not been widely reported. Nevertheless, this is an attractive approach due its reliability, variable distribution network, and power factor requirements. Industrial vendors offer EMS platforms capable of integrating downstream information from smart-meters and local controllers as well as upstream services such as cloud-based market analytics software.

Even though the process information required in DSM mining applications can be integrated by using industrial platforms, and the required optimization tools are available, the knowledge obtained from technical reports indicates that medium- and long-term projects that involve multidisciplinary teams and technological updates, are expensive and not very attractive from the business point of view. However, as indicated in Section IV, the power profile of comminution circuits, which represents the highest power demand in mining, can be improved by using DSM strategies. Similarly, auxiliary processes such as water pumping and desalination have the potential to be included in DSM and EMS controllers since they are more flexible loads than the main processes.

Although there are commercial solutions for MPC and EMS, these are not usually deployed in industrial plants. New information paradigms, such as industrial-internet-of-the-things (IIoT), may help in building confidence in these solutions as they facilitate thorough acceptance tests while reducing their execution time. The integration of advanced metering in mines provides data that can be used in analytics systems as well as in models required by MPC, EMS and DSM, or in computational tools such as digital plants (digital twin models). For the mining industry this confidence is imperative to draw the mine prospective, but also because a failure in the power system or mining process can quickly become catastrophic.

Microgrids are more reliable than typical power networks in mining. The integration of distributed generation and distributed control schemes brings autonomy and flexibility to the mining process, reducing the probability of blackouts and shutdowns. Cases in which the mining process and the microgrid are integrated procure a safer operation while also achieving economic and environmental profits. Considering the power volume required by mining operations, if autonomy is achieved based on RES, it is possible to then

supply services to the utility grid, even after the mine is closed.

Finally, the insertion of microgrids in heavy-industry environments, such as mining, represents a worldwide challenge, which is aligned with international efforts for carbon footprint mitigation. Though each mine has particular concerns for microgrid integration, applications developed in the northern regions of Chile, one of the main world producers of copper, will be of remarkable interest to both industrial and academic communities. In 2016, it was estimated that the mining industry in Chile consumed 30% of the total power and produced 17% of the total green-house gases emissions in this country, without considering the footprint of mineral transportation and mining wastes [90]. Paradoxically enough, this country is uniquely positioned to develop solar energy solutions as it has annual global irradiance values exceeding 2500 kWh/m² [91], but its primary power generation depends on fossil fuels. With this background, it is understandable that Chile has an ambitious target to generate 20% of its electricity from renewable sources by 2025 [92] and its energy policies are also promoting the implementation of EMS in the mining industry [90].

VI. CONCLUSION

As with other heavy-industries, mining is a required economic activity for the development of societies. Therefore, advocating for cleaner processes and optimal use of resources, such as electric power, is essential. Nowadays, policy makers are promoting the integration of renewable resources in this type of industry. The technological transition and the inherent coexistence between old and new technologies imply engineering challenges that can be addressed from the microgrids perspective.

At the bottom of the control hierarchy, the integration of control objectives related to power quality and regenerative power harnessing in power electronics devices, is identified as a key step towards more reliable power networks in mining. At the top, the integration of multidisciplinary data from the mine and the power system, as well as analytics services, will bring powerful tools to develop optimal energy and demand-management strategies, which could also be implemented in auxiliary processes such as water pumping and desalination.

Finally, some of the challenges detailed in this article can be addressed by using a variety of techniques. However, the adaptation of such techniques to the mining environment, which is necessary in order to achieve the reliability and performance required by this industry, will require additional R&D efforts that needs to be made in the near future.

REFERENCES

- [1] United Nations, *Paris Agreement*. Paris, France: United Nations Climate Change, 2015, ch. 27.
- [2] S. Miyanaga, "Achieving net-zero emissions by 2050 will rest on these 3 pillars," in *Proc. World Econ. Forum Annu. Meeting*, Jan. 2020. Accessed: Aug. 15, 2020. [Online]. Available: <https://www.weforum.org/agenda/2020/01/whether-we-achieve-zero-emissions-rests-on-these-3-pillars/>
- [3] J. Haas, S. Moreno-Leiva, T. Junne, P.-J. Chen, G. Pamparana, W. Nowak, W. Kracht, and J. M. Ortiz, "Copper mining: 100% solar electricity by 2030?" *Appl. Energy*, vol. 262, Mar. 2020, Art. no. 114506.
- [4] N. Maennling and P. Toledano, "The renewable power of the mine: Accelerating renewable energy integration," Columbia Center Sustain. Investment, New York, NY, USA, Tech. Rep., Dec. 2018. [Online]. Available: <http://www.bmz.de/rue/en/index.html>
- [5] Y. Choi and J. Song, "Review of photovoltaic and wind power systems utilized in the mining industry," *Renew. Sustain. Energy Rev.*, vol. 75, pp. 1386–1391, Aug. 2017.
- [6] Rocky Mountain Institute. (2019). *Renewable Resources at Mines Tracker*. [Online]. Available: <https://rmi.org/our-work/industry-and-transportation/material-value-chains/renewable-resources-at-mines-tracker/>
- [7] M. Taylor, "Energy subsidies: Evolution in the global energy transformation to 2050," Int. Renew. Energy Agency, Abu Dhabi, United Arab Emirates, Staff Tech. Paper, 2020.
- [8] W. J. Cole and A. Frazier, "Cost projections for utility-scale battery storage," Nat. Renew. Energy Lab., Golden, CO, USA, Tech. Rep. NREL/TP-6A20-73222, Jun. 2019.
- [9] J. M. Guerrero, J. C. Vasquez, J. Matas, L. G. de Vicuna, and M. Castilla, "Hierarchical control of droop-controlled AC and DC microgrids—A general approach toward standardization," *IEEE Trans. Ind. Electron.*, vol. 58, no. 1, pp. 158–172, Jan. 2011.
- [10] *Standard for Interconnection and Interoperability of Distributed Energy Resources with Associated Electric Power Systems Interfaces*, IEEE Standard 1547-2018, 2018.
- [11] S. Moreno-Leiva, J. Haas, T. Junne, F. Valencia, H. Godin, W. Kracht, W. Nowak, and L. Eltrop, "Renewable energy in copper production: A review on systems design and methodological approaches," *J. Cleaner Prod.*, vol. 246, Feb. 2020, Art. no. 118978.
- [12] D. E. Olivares, A. Mehrizi-Sani, A. H. Etemadi, C. A. Cañizares, M. Irvani, M. Kazerani, A. H. Hajimiragha, O. Gomis-Bellmunt, M. Saeedifard, R. Palma-Behnke, G. A. Jiménez-Estévez, and N. D. Hatziargyriou, "Trends in microgrid control," *IEEE Trans. Smart Grid*, vol. 5, no. 4, pp. 1905–1919, Jul. 2014.
- [13] J. Rodríguez, J.-S. Lai, and F. Zheng Peng, "Multilevel inverters: A survey of topologies, controls, and applications," *IEEE Trans. Ind. Electron.*, vol. 49, no. 4, pp. 724–738, Aug. 2002.
- [14] A. M. Bouzid, J. M. Guerrero, A. Cheriti, M. Bouhamida, P. Sicard, and M. Benghanem, "A survey on control of electric power distributed generation systems for microgrid applications," *Renew. Sustain. Energy Rev.*, vol. 44, pp. 751–766, Apr. 2015.
- [15] Y. Han, H. Li, P. Shen, E. A. A. Coelho, and J. M. Guerrero, "Review of active and reactive power sharing strategies in hierarchical controlled microgrids," *IEEE Trans. Power Electron.*, vol. 32, no. 3, pp. 2427–2451, Mar. 2017.
- [16] J. W. Simpson-Porco, Q. Shafiee, F. Dorfler, J. C. Vasquez, J. M. Guerrero, and F. Bullo, "Secondary frequency and voltage control of islanded microgrids via distributed averaging," *IEEE Trans. Ind. Electron.*, vol. 62, no. 11, pp. 7025–7038, Nov. 2015.
- [17] E. Espina, R. Cardenas-Dobson, M. Espinoza-B., C. Burgos-Mellado, and D. Saez, "Cooperative regulation of imbalances in three-phase four-wire microgrids using single-phase droop control and secondary control algorithms," *IEEE Trans. Power Electron.*, vol. 35, no. 2, pp. 1978–1992, Feb. 2020.
- [18] J. Llanos, D. E. Olivares, J. W. Simpson-Porco, M. Kazerani, and D. Saez, "A novel distributed control strategy for optimal dispatch of isolated microgrids considering congestion," *IEEE Trans. Smart Grid*, vol. 10, no. 6, pp. 6595–6606, Nov. 2019.
- [19] A. Gupta, S. Doolla, and K. Chatterjee, "Hybrid AC–DC microgrid: Systematic evaluation of control strategies," *IEEE Trans. Smart Grid*, vol. 9, no. 4, pp. 3830–3843, Jul. 2018.
- [20] E. Planas, A. Gil-de-Muro, J. Andreu, I. Kortabarria, and I. Martínez de Alegría, "General aspects, hierarchical controls and droop methods in microgrids: A review," *Renew. Sustain. Energy Rev.*, vol. 17, pp. 147–159, Jan. 2013.
- [21] Y. Khayat, Q. Shafiee, R. Heydari, M. Naderi, T. Dragicevic, J. W. Simpson-Porco, F. Dorfler, M. Fathi, F. Blaabjerg, J. M. Guerrero, and H. Bevrani, "On the secondary control architectures of AC microgrids: An overview," *IEEE Trans. Power Electron.*, vol. 35, no. 6, pp. 6482–6500, Jun. 2020.
- [22] I. Serban, S. Cespedes, C. Marinescu, C. A. Azurdia-Meza, J. S. Gomez, and D. S. Hueichapan, "Communication requirements in microgrids: A practical survey," *IEEE Access*, vol. 8, pp. 47694–47712, 2020.

- [23] M. Saleh, Y. Esa, and A. A. Mohamed, "Communication-based control for DC microgrids," *IEEE Trans. Smart Grid*, vol. 10, no. 2, pp. 2180–2195, Mar. 2019.
- [24] J. S. Gomez, D. Saez, J. W. Simpson-Porco, and R. Cardenas, "Distributed predictive control for frequency and voltage regulation in microgrids," *IEEE Trans. Smart Grid*, vol. 11, no. 2, pp. 1319–1329, Mar. 2020.
- [25] D. Espín-Sarzosa, R. Palma-Behnke, and O. Núñez-Mata, "Energy management systems for microgrids: Main existing trends in centralized control architectures," *Energies*, vol. 13, no. 3, p. 547, Jan. 2020.
- [26] F. A. Mohamed and H. N. Koivo, "Online management of MicroGrid with battery storage using multiobjective optimization," in *Proc. Int. Conf. Power Eng., Energy Elect. Drives*, Apr. 2007, pp. 231–236.
- [27] A. Chaouachi, R. M. Kamel, R. Andoulsi, and K. Nagasaka, "Multiobjective intelligent energy management for a microgrid," *IEEE Trans. Ind. Electron.*, vol. 60, no. 4, pp. 1688–1699, Apr. 2013.
- [28] L. G. Marín, M. Sumner, D. Muñoz-Carpintero, D. Köbrich, S. Pholboon, D. Sáez, and A. Núñez, "Hierarchical energy management system for microgrid operation based on robust model predictive control," *Energies*, vol. 12, no. 23, p. 4453, Nov. 2019.
- [29] R. Palma-Behnke, G. A. Jimenez-Estevéz, D. Saez, M. Montedónico, P. Mendoza-Araya, R. Hernandez, and C. Muñoz Poblete, "Lowering electricity access barriers by means of participative processes applied to microgrid solutions: The Chilean case," *Proc. IEEE*, vol. 107, no. 9, pp. 1857–1871, Sep. 2019.
- [30] P. A. Madduri, J. Poon, J. Rosa, M. Podolsky, E. A. Brewer, and S. R. Sanders, "Scalable DC microgrids for rural electrification in emerging regions," *IEEE J. Emerg. Sel. Topics Power Electron.*, vol. 4, no. 4, pp. 1195–1205, Dec. 2016.
- [31] A. W. Colombo, S. Karnouskos, O. Kaynak, Y. Shi, and S. Yin, "Industrial cyberphysical systems: A backbone of the fourth industrial revolution," *IEEE Ind. Electron. Mag.*, vol. 11, no. 1, pp. 6–16, Mar. 2017.
- [32] N. W. A. Lidula and A. D. Rajapakse, "Microgrids research: A review of experimental microgrids and test systems," *Renew. Sustain. Energy Rev.*, vol. 15, no. 1, pp. 186–202, Jan. 2011.
- [33] M. H. Cintuglu, O. A. Mohammed, K. Akkaya, and A. S. Uluagac, "A survey on smart grid cyber-physical system testbeds," *IEEE Commun. Surveys Tuts.*, vol. 19, no. 1, pp. 446–464, 1st Quart., 2017.
- [34] *Infinite Insight ABB Ability e-Mesh*, ABB, Baden-Dättwil, Switzerland, 2019.
- [35] *Advanced Control for Onsite Energy Optimization*, Siemens, Munich, Germany, 2016, pp. 1–4.
- [36] *Mining Industry Energy Bandwidth Study*, Office Energy Efficiency Renew. Energy, US Dept. Energy, Washington, DC, USA, 2007, pp. 1–47.
- [37] M. G. Jahromi, G. Mirzaeva, S. D. Mitchell, and D. Gay, "Powering mobile mining machines: DC versus AC power," *IEEE Ind. Appl. Mag.*, vol. 22, no. 5, pp. 63–72, Sep. 2016.
- [38] P. Aqueveque, E. P. Wiechmann, J. A. Henriquez, and L. G. Muñoz, "Energy quality and efficiency of an open pit mine distribution system: Evaluation and solution," *IEEE Trans. Ind. Appl.*, vol. 52, no. 1, pp. 580–588, Jan. 2016.
- [39] L. Moran, D. Sbarbaro, F. Ortega, and J. Espinoza, "Electrical energy consumption characterization of open-pit mining and mineral processing operations towards the use of renewable energy sources," in *Proc. IEEE Ind. Appl. Soc. Annu. Meeting*, Sep. 2019, pp. 1–6.
- [40] A. Soofastaei, E. Karimpour, P. Knights, and M. Kizil, *Energy Efficiency in the Minerals Industry*, (Green Energy and Technology), K. Awuah-Offei, Ed. Cham, Switzerland: Springer, 2018.
- [41] J. Yaghoobi, A. Abdullah, D. Kumar, F. Zare, and H. Soltani, "Power quality issues of distorted and weak distribution networks in mining industry: A review," *IEEE Access*, vol. 7, pp. 162500–162518, 2019.
- [42] O. Abdel-baqi, A. Nasiri, and P. Miller, "Dynamic performance improvement and peak power limiting using ultracapacitor storage system for hydraulic mining shovels," *IEEE Trans. Ind. Electron.*, vol. 62, no. 5, pp. 3173–3181, May 2015.
- [43] M. Osanloo and M. Paricheh, "In-pit crushing and conveying technology in open-pit mining operations: A literature review and research agenda," *Int. J. Mining, Reclam. Environ.*, vol. 34, no. 6, pp. 430–457, Jan. 2019.
- [44] M. Z. Bebic and L. B. Ristic, "Speed controlled belt conveyors: Drives and mechanical considerations," *Adv. Electr. Comput. Eng.*, vol. 18, no. 1, pp. 51–60, 2018.
- [45] M. Perrucci, "Conveying progress," *ABB Rev.*, vols. 3–14, pp. 12–17, Mar. 2014.
- [46] Siemens Mobile Mining Industry, Nuremberg, Germany. (2019). *SIMINE Haul Truck*. [Online]. Available: <https://siemens.com/mobile.mining>
- [47] ABB. (2020). *Driving Boliden's Electric Transformation*. [Online]. Available: <https://new.abb.com/mining/reference-stories/open-pit-mining/driving-boliden-s-electric-transformation>
- [48] D. Gleeson, "Trolley assist to take off, ABB's Hammarström says," *Int. Min.*, Dec. 2019. Accessed: May 17, 2020. [Online]. Available: <https://imining.com/2019/11/21/trolley-assist-take-off-abbs-hammarstrom-says/>
- [49] W. G. Koellner, G. M. Brown, J. Rodriguez, J. Pontt, P. Cortes, and H. Miranda, "Recent advances in mining haul trucks," *IEEE Trans. Ind. Electron.*, vol. 51, no. 2, pp. 321–329, Apr. 2004.
- [50] J. Valenzuela Cruzat and M. A. Valenzuela, "Modeling and evaluation of benefits of trolley assist system for mining trucks," *IEEE Trans. Ind. Appl.*, vol. 54, no. 4, pp. 3971–3981, Jul. 2018.
- [51] V. Nadipuram, "Bigger is better," *ABB Rev.*, vols. 3–14, pp. 25–30, Mar. 2014.
- [52] V. Iyer and L. Barun, *Innovations and Breakthroughs in the Gold and Silver Industries*, vol. 1, V. I. Lakshmanan and B. Gorain, Eds. Cham, Switzerland: Springer, 2019.
- [53] J. R. Rodriguez, J. Pontt, P. Newman, R. Musalem, H. Miranda, L. Moran, and G. Alzamora, "Technical evaluation and practical experience of high-power grinding mill drives in mining applications," *IEEE Trans. Ind. Appl.*, vol. 41, no. 3, pp. 866–874, May 2005.
- [54] G. Seggewiss, J. Dai, and M. Fanslow, "Synchronous motors on grinding mills: The different excitation types and resulting performance characteristics with VFD control for new or retrofit installations," *IEEE Ind. Appl. Mag.*, vol. 21, no. 6, pp. 60–67, Nov. 2015.
- [55] F. C. Vaca, L. Reyes-Bozo, H. Valdes-Gonzalez, C. F. Guerra, R. Galleguillos-Pozo, M. V. Garcia, and E. Vyhmeister, "Controlled high pressure grinding roll by model predictive control," in *Proc. IEEE 3rd Colombian Conf. Autom. Control (CCAC)*, Oct. 2017, pp. 1–6.
- [56] V. Guerrero and J. Pontt, "Oscillatory torque caused by dead time in the current control of high power gearless mills," in *Proc. 37th Annu. Conf. IEEE Ind. Electron. Soc. (IECON)*, no. 1, Nov. 2011, pp. 1966–1970.
- [57] D. Berrios and T. Roesch, "Frozen charge detection and automatic loosening with gearless mill drives," in *Proc. SAG Conf.*, Vancouver, BC, Canada: Siemens, 2015, pp. 1–6.
- [58] J. D. le Roux, S. Skogestad, and I. K. Craig, "Plant-wide control of grinding mill circuits: top-down analysis," *IFAC-PapersOnLine*, vol. 49, no. 20, pp. 72–77, 2016.
- [59] J. Bouchard, A. Desbiens, and É. Poulin, "Reducing the energy footprint of grinding circuits: The process control paradigm," *IFAC-PapersOnLine*, vol. 50, no. 1, pp. 1163–1168, Jul. 2017.
- [60] J. M. Ortiz, W. Kracht, G. Pamparana, and J. Haas, "Optimization of a SAG mill energy system: Integrating rock hardness, solar irradiation, climate change, and demand-side management," *Math. Geosci.*, vol. 52, no. 3, pp. 355–379, Apr. 2020.
- [61] J. Zhou, S. Kim, H. Zhang, Q. Sun, and R. Han, "Consensus-based distributed control for accurate reactive, harmonic, and imbalance power sharing in microgrids," *IEEE Trans. Smart Grid*, vol. 9, no. 4, pp. 2453–2467, Jul. 2018.
- [62] *Drives for Every Demand Core Applications and Product Highlights Digitalization Offering*, Siemens, Nuremberg, Germany, 2019.
- [63] H. Wiechmann and K. Tischer, "Mining technologies Comparison of alternative converters with regard to their application for gearless drives for grinding mills," in *Proc. Workshop SAG*, Oct. 2007, pp. 1–12.
- [64] J. Pontt, J. Rodriguez, W. Valderrama, G. Sepulveda, P. Chavez, B. Cuitino, P. Gonzalez, and G. Alzamora, "Current issues on high-power cycloconverter-fed gearless motor drives for grinding mills," in *Proc. IEEE Int. Symp. Ind. Electron.*, vol. 1, Jun. 2003, pp. 369–374.
- [65] L. Moran, J. Espinoza, and R. Burgos, "Voltage regulation in mine power distribution systems: Problems and solutions," in *Proc. IEEE Ind. Appl. Soc. Annu. Meeting*, Oct. 2014, pp. 1–7.
- [66] J. Sottile, T. Novak, and A. K. Tripathi, "Best practices for implementing high-resistance grounding in mine power systems," *IEEE Trans. Ind. Appl.*, vol. 51, no. 6, pp. 5254–5260, Nov. 2015.
- [67] R. N. Fard and E. Tedeschi, "Power system design considerations for a seafloor mining vehicle," in *Proc. IEEE Energy Convers. Congr. Expo. (ECCE)*, Sep. 2018, pp. 1164–1171.
- [68] C. Yuan, M. A. Haj-ahmed, and M. S. Illindala, "Protection strategies for medium-voltage direct-current microgrid at a remote area mine site," *IEEE Trans. Ind. Appl.*, vol. 51, no. 4, pp. 2846–2853, Jul. 2015.
- [69] M. Espinoza, R. Cardenas, M. Diaz, and J. C. Clare, "An enhanced dq-based vector control system for modular multilevel converters feeding variable-speed drives," *IEEE Trans. Ind. Electron.*, vol. 64, no. 4, pp. 2620–2630, Apr. 2017.

- [70] M. Diaz, R. Cardenas, M. Espinoza, C. M. Hackl, F. Rojas, J. C. Clare, and P. Wheeler, "Vector control of a modular multilevel matrix converter operating over the full output-frequency range," *IEEE Trans. Ind. Electron.*, vol. 66, no. 7, pp. 5102–5114, Jul. 2019.
- [71] L. Moran, C. A. Albistur, and R. Burgos, "Multimega VAR passive filters for mining applications: Practical limitations and technical considerations," *IEEE Trans. Ind. Appl.*, vol. 52, no. 6, pp. 5310–5317, Nov. 2016.
- [72] T.-L. Lee, Y.-C. Wang, J.-C. Li, and J. M. Guerrero, "Hybrid active filter with variable conductance for harmonic resonance suppression in industrial power systems," *IEEE Trans. Ind. Electron.*, vol. 62, no. 2, pp. 746–756, Feb. 2015.
- [73] M. A. Masoum and E. F. Fuchs, "The roles of filters in power systems and unified power quality conditioners," in *Proc. Power Qual. Power Syst. Elect. Mach.* Amsterdam, The Netherlands: Elsevier, 2015, pp. 779–886.
- [74] G. S. Chawda, A. G. Shaik, O. P. Mahela, S. Padmanaban, and J. B. Holm-Nielsen, "Comprehensive review of distributed FACTS control algorithms for power quality enhancement in utility grid with renewable energy penetration," *IEEE Access*, vol. 8, pp. 107614–107634, 2020.
- [75] S. Devassy and B. Singh, "Control of a solar photovoltaic integrated universal active power filter based on a discrete adaptive filter," *IEEE Trans. Ind. Informat.*, vol. 14, no. 7, pp. 3003–3012, Jul. 2018.
- [76] N. K. Swami Naidu and B. Singh, "Doubly fed induction generator for wind energy conversion systems with integrated active filter capabilities," *IEEE Trans. Ind. Informat.*, vol. 11, no. 4, pp. 923–933, Aug. 2015.
- [77] F. Nejabatkhah and Y. W. Li, "Overview of power management strategies of hybrid AC/DC microgrid," *IEEE Trans. Power Electron.*, vol. 30, no. 12, pp. 7072–7089, Dec. 2015.
- [78] K. Zharan and J. C. Bongaerts, "Decision-making on the integration of renewable energy in the mining industry: A case studies analysis, a cost analysis and a SWOT analysis," *J. Sustain. Mining*, vol. 16, no. 4, pp. 162–170, 2017.
- [79] S. Nasirov and C. A. Agostini, "Mining experts' perspectives on the determinants of solar technologies adoption in the Chilean mining industry," *Renew. Sustain. Energy Rev.*, vol. 95, pp. 194–202, Nov. 2018.
- [80] OECD, "Integrating renewables in mining: Review of business models and policy implications," OECD, Paris, France, Tech. Rep. 14, 2018.
- [81] K. Pollack and J. C. Bongaerts, "Mathematical model on the integration of renewable energy in the mining industry," *Int. J. Energy Sector Manage.*, vol. 14, no. 1, pp. 229–247, Jan. 2020.
- [82] C. Valenzuela, C. Mata-Torres, J. M. Cardemil, and R. A. Escobar, "CSP + PV hybrid solar plants for power and water cogeneration in northern Chile," *Sol. Energy*, vol. 157, pp. 713–726, Nov. 2017.
- [83] J. Barrientos, J. López, and F. Valencia, "A novel stochastic-programming-based energy management system to promote self-consumption in industrial processes," *Energies*, vol. 11, no. 2, p. 441, Feb. 2018.
- [84] THEnergy. *Database: Solar & Wind Systems in the Mining Industry*. [Online]. Available: <https://www.th-energy.net/english/platform-renewable-energy-and-mining/database-solar-wind-power-plants/>
- [85] Z. Li, M. Shahidehpour, F. Aminifar, A. Alabdulwahab, and Y. Al-Turki, "Networked microgrids for enhancing the power system resilience," *Proc. IEEE*, vol. 105, no. 7, pp. 1289–1310, Jul. 2017.
- [86] E. Hammad, "Resilient cooperative microgrid networks," *IEEE Trans. Ind. Informat.*, vol. 16, no. 3, pp. 1539–1548, Mar. 2020.
- [87] S. Yao, P. Wang, and T. Zhao, "Transportable energy storage for more resilient distribution systems with multiple microgrids," *IEEE Trans. Smart Grid*, vol. 10, no. 3, pp. 3331–3341, May 2019.
- [88] M. Choobineh, D. Silva-Ortiz, and S. Mohagheghi, "An automation scheme for emergency operation of a multi-microgrid industrial park," *IEEE Trans. Ind. Appl.*, vol. 54, no. 6, pp. 6450–6459, Nov. 2018.
- [89] H. G. Brand, J. C. Vosloo, and E. H. Mathews, "Automated energy efficiency project identification in the gold mining industry," in *Proc. Int. Conf. Ind. Commercial Use Energy (ICUE)*, Aug. 2015, pp. 17–22.
- [90] *Tercer Informe Bienal de Actualización de Chile Sobre Cambio Climático 2018*, Ministry Environ.-Chile, Santiago, Chile, 2018.
- [91] F. Valencia, R. Palma-Behnke, D. Ortiz-Villalba, A. De La Quintana, C. Rahmann, and R. Cifuentes, "Special protection systems: Challenges in the Chilean market in the face of the massive integration of solar energy," *IEEE Trans. Power Del.*, vol. 32, no. 1, pp. 575–584, Feb. 2017.
- [92] *Renewable Energy Policy Brief Chile*, Int. Renew. Energy Agency, Abu Dhabi, United Arab Emirates, Jun. 2015.



JUAN S. GÓMEZ was born in Bogotá, Colombia. He received the B.E. degree in electronics engineering from Universidad Distrital Francisco José de Caldas, Bogotá, in 2011, and the Ph.D. degree in electrical engineering from the Universidad de Chile, Santiago, Chile, in 2020. He is currently affiliated as a Postdoctoral Researcher on microgrids applications for mining industry with the Pontificia Universidad Católica de Chile (Anillo project ACT192013). He previously worked in the Colombian oil and gas industry as a Project Engineer and as Automation Specialist Engineer from 2010 to 2016. His research interests include microgrids control, networked control systems, renewable energies, and model-based predictive control.



JOSE RODRIGUEZ (Life Fellow, IEEE) received the engineer degree in electrical engineering from Universidad Tecnica Federico Santa Maria, Valparaiso, Chile, in 1977, and the Dr.-Ing. degree in electrical engineering from the University of Erlangen, Erlangen, Germany, in 1985. He has been with the Department of Electronics Engineering, Universidad Tecnica Federico Santa Maria, since 1977, where he was a Full Professor and the President. Since 2015, he has also been the President. Since 2019, he has also been a Full Professor with Universidad Andrés Bello, Santiago, Chile. He has coauthored two books, several book chapters, and more than 400 journal and conference papers. His research interests include multilevel inverters, new converter topologies, control of power converters, and adjustable-speed drives. He is also a member of the Chilean Academy of Engineering. He received a number of best paper awards from journals of the IEEE. In 2014, he received the National Award of Applied Sciences and Technology from the government of Chile. In 2015, he received the Eugene Mittelmann Award from the Industrial Electronics Society of the IEEE. In years 2014 to 2019, he has been included in the list of Highly Cited Researchers published by Web of Science.



CRISTIAN GARCIA (Member, IEEE) received the M.Sc. and Ph.D. degrees in electronics engineering from the Universidad Tecnica Federico Santa Maria (UTFSM), Valparaiso, Chile, in 2013 and 2017, respectively. From 2017 to 2019, he was with the Engineering Faculty, Universidad Andrés Bello, Santiago, Chile, as an Assistant Professor. Since 2019, he has been with the Department of Electrical Engineering, University of Talca, Curicó, Chile, where he is currently an Assistant Professor. In 2016, he was a Visiting Ph.D. Student with the Power Electronics Machines and Control (PEMC) Group, University of Nottingham, U.K. His research interests include electric transportation applications, variable-speed drives, and model predictive control of power converters and drives.



LUCA TARISCIOTTI (Member, IEEE) received the master's degree in electronic engineering from the University of Rome Tor Vergata, in 2009, and the Ph.D. degree in electrical and electronic engineering from the PEMC Group, University of Nottingham, U.K., in 2015. In the same year, he became a Research Fellow at the University of Nottingham, until 2018. He is currently working as an Assistant Professor with Universidad Andrés Bello, Santiago, Chile. His research interests include matrix converters, DC/DC converters, multilevel converters, advanced modulation schemes, and advanced power electronics converter control.



FREDDY FLORES-BAHAMONDE (Member, IEEE) was born in Osorno, Chile, in 1983. He received the M.Sc. and Ph.D. degrees in electronics engineering from Universitat Rovira i Virgili (URV), Tarragona, Spain, in 2009 and 2013, respectively. In 2015, he joined to the Advanced Center for Electrical and Electronic Engineering (AC3E), Universidad Técnica Federico Santa María (UTFSM), Valparaíso, Chile, as a Post-doctoral Fellow. In 2017, he was in charge of

the energy area in the technology transfer unit of the AC3E developing and managing industrial projects related to the energy and electric power systems field. He is currently an Assistant Professor with the Department of Engineering Sciences, Universidad Andrés Bello, where he is also a Researcher with the Energy Transformation Center. His research interests include the design and control of power converters for renewable energies, automotive power systems, and dc microgrids.



JAVIER PEREDA (Member, IEEE) received the B.Sc. (Eng.) degree (Hons.) in electrical engineering and the M.Sc. and Ph.D. degrees in electrical engineering from the Pontifical Catholic University of Chile, Santiago, Chile, in 2009 and 2013, respectively. He has been an Assistant Professor with the Department of Electrical Engineering, Pontificia Universidad Católica de Chile, since 2013. From 2014 to 2016, he was an Associate Research of the Control and Power Group, Department of Electrical and Electronic Engineering, Imperial College London.

He is currently an Associate Research of the Solar Energy Research Center, Chile, and the UC Energy Research Center, Chile. He is also the Principal Investigator of the Electric Vehicle Laboratory and the Power and Energy Conversion Laboratory (PEClab), Pontificia Universidad Católica de Chile. His research interests include power electronics and control applied to electric vehicles, ac and dc electric networks, microgrids, renewable energy, multilevel converters, industrial applications, and motor drives.



FELIPE NUÑEZ (Member, IEEE) was born in Santiago, Chile. He received the B.Sc. and M.Sc. degrees in electrical engineering from the Pontificia Universidad Católica de Chile, in 2007 and 2008, respectively, and the Ph.D. degree in electrical and computer engineering from the University of California, Santa Barbara, in 2014. In 2015, he was with the UCSB/MIT/Caltech Institute for Collaborative Biotechnologies. In 2016, he joined the Department of Electrical Engineering, Pontificia Universidad Católica de Chile, where he is currently an Assistant Professor. His research interests include control of networks, cyber-physical systems, hybrid dynamical systems, sensor and computer networks, industrial automation, model predictive control, and mineral processing.



ALDO Z. CIPRIANO (Senior Member, IEEE) received the M.Sc. degree from the University of Chile, in 1974, and the Doktor Ingenieur degree from Technical University Munich, in 1981. He has 45 years of academic and professional experience leading Research and Development and industrial projects and doing teaching and consulting. He was the Dean of the School of Engineering. He is currently the President of Dictuc S. A., Emeritus Professor of automation and control engineering and an Associate Dean for Extension with the School of Engineering, Pontificia Universidad Católica de Chile. He is also a member of the Chilean Academy of Engineering. He received several awards, including the Raúl Devés Jullian 2019 Award from the Chilean Institute of Engineers.



JUAN CARLOS SALAS was born in Chile. He received the B.Sc. degree in chemical engineering from the Universidad de Chile, Santiago, Chile, in 1981, and the M.Sc. and Ph.D. degrees in materials science and mineral engineering from the University of California at Berkeley, Berkeley, CA, USA, in 2003 and 2004, respectively.

He started his career in 1981 at the Chuquicamata Mine, Chuquicamata, Chile. In 1998, he was appointed as a General Manager of the Institute of Innovation in Mining and Metallurgy, Santiago. In 2005, he was also appointed as a Latin America Manager of AMIRA International Ltd., Melbourne, VIC, Australia. In 2008, he was also appointed as an Innovation Manager of the Antofagasta Minerals Group, Santiago. In 2012, he was also appointed as a General Manager of the Latin America of Xstrata Technology, Santiago. Since 2015, he has been with the Department of Mining Engineering, Pontificia Universidad Católica de Chile, Santiago. His research interests include optimization of metallurgical processes, application of intelligent control systems in mining processes, and management of minor metals in extractive metallurgy.

...