

Received August 30, 2020, accepted September 18, 2020, date of publication October 6, 2020, date of current version October 21, 2020.

Digital Object Identifier 10.1109/ACCESS.2020.3029163

Application of Incentive-Type Variable Weight in Decision of 500/220kV Received Electromagnetic Looped Grid Decomposing Operation

HAIYUN WANG¹, ZHIJIAN ZHANG², JINYANG DONG²,
YUXUAN ZHANG¹, HAO WU^{1,3,4}, AND WENCHAO ZHANG³

¹Electric Power Research Institute, State Grid Beijing Electric Power Company, Beijing 100075, China

²State Grid Beijing Electric Power Company, Beijing 100031, China

³Beijing Kedong Electric Power Control System Company Ltd., Beijing 100192, China

⁴Shanxi Key Laboratory of Power System Operation and Control, Taiyuan University of Technology, Taiyuan 030024, China

Corresponding author: Hao Wu (13834404995@163.com)

This work was supported by the Science and Technology Project of Research on Analysis and Evaluation Algorithm Technology for Optimal Operation Mode of Beijing Power Grid through State Grid Beijing Electric Power Company.

ABSTRACT With the construction of 500kV grid, the 500/220kV electromagnetic looped grid of the received power grid will make short current problems stand out. Effectively and economically, considering the measure of the short current limitation, it is essential to decompose electromagnetic looped grid. Based on grid characteristics, grid operation arrangement should be optimized by strategy. Hence, the aspects, such as topological structure, security and stability, power supply reliability, operation economy and appropriate planning should be considered in decomposing 500/220kV electromagnetic looped grid and establishing evaluation index of the grid characteristics. With calculating constant weight by using maximizing deviation, the incentive-type variable weight multi-attribute decision model is proposed according to variable weight theory. This model guarantees objective analysis of the constant weight and extends discrimination of different potential schemes, simultaneously, the decision model's effect will be improved from two perspectives of the index and the scheme. Last, based on evaluation index and decision model raised by this article, the real 500/200kV received electromagnetic looped grid will be decomposed and analyzed by different schemes, the accuracy and effectiveness of the conclusion obtained by incentive-type variable weight multi-attribute decision model is verified.

INDEX TERMS Decomposing grid, evaluation index, grid operation arrangement, multi-attribute decision, received electromagnetic looped grid, variable weight theory.

I. INTRODUCTION

With power generation increase in power base and load increase of the load part, the 'generated-received' power grid model is more and more obvious [1]. As 500kV grid construction completed, the grid system impedance is decreased by developed 500/220kV electromagnetic looped grid. Load growth and extra high voltage system appearance will aggravate the short current problems [2], [3]. Meanwhile, a large number of power outage problems are caused by received electromagnetic looped grid [4], [5]. Therefore, 500/220kV received electromagnetic looped grid should be decomposed to satisfy grid operation at the right time. In various decom-

posing schemes, the power grid operates differently, the key research point is to choose the most suitable decomposed received electromagnetic looped grid plan.

To establish the whole evaluation index system when analyzing decision target's characteristics, it is an effective decision way to quantitatively evaluate in an appropriate decision model [6]. In paper [7] by associate professor Jin, through the failure characteristic by the electrical signal and frequency signal of wind generator, the wind generator healthy situation evaluation index was established. Based on relative dimension analysis, the evaluation model was raised, and the wind generator healthy situation can be evaluated precisely. Whole characteristics of the power grid are mainly expressed from the aspects, such as power flow distribution, short current, stability operation, reliable power supply [8]–[11], which are

The associate editor coordinating the review of this manuscript and approving it for publication was Huai-Zhi Wang^{id}.

the main aim to establish grid operation evaluation index. In grid topology analysis, complex network theory has been widely applied. Modularity measure has been a measurement standard for power grid judgement [12]. In paper [13], [14], the capabilities and requirements of the main received power grid structure has been analyzed to adapt to the changes in development and operation mode and to ensure the safe and stable operation of the power grid. In paper [15], with influence of equipment's important difference to power grid operation, applicability and rationality are strengthened by setting correction factor.

The characteristics of the decision target reflected by the evaluation index are different, and the weight of each index needs to be calculated through the decision model to reflect the role of various indexes in the decision-making process. Usually, Delphi method [16], analytic hierarchy method [17], principal component analysis method [18], coefficient of variation method [19], and etc. are constant weight calculation methods. Those methods are just based on the same index in various scheme to calculate weight. The influence of index's change trend in the same scheme is ignored on the weight. So variable weight is applied in decision model [20]. In paper [21], to fulfill real engineering project and enhance evaluation results, a method for evaluating the operation status of transmission lines based on variable weight theory and fuzzy comprehensive evaluation was proposed. In paper [22], a transformer state evaluation model was constructed based on association rules and variable weights, which can more truly reflect the actual operating conditions of the transformer.

Overall, in this article, the evaluation index of the 500/220kV received electromagnetic looped grid operation after decomposed is reestablished from aspects such as power grid topology, security stability operation, power supply reliability, economy and planning adaption. Then the constant weight of the index is calculated by maximizing the deviation, which can distinguish the pros and cons of the schemes and avoid the randomness of the weights. Based on the variable weight theory, incentive-type variable weight multi-attribute decision model is raised. In this article, evaluation index system and decision model are put forward, which can solve quantized evaluation problem of the decomposed received electromagnetic looped grid, and provide a technical support for power grid operation.

II. EVALUATION INDEX OF OPEN LOOP OPERATION MODE OF 500/200kV RECEIVED ELECTROMAGNETIC LOOPED GRID

The open loop operation mode of electromagnetic loop network changes the backbone network of power system. Evaluation index is used for estimating its rationality from network topology. Typically, power system needs to satisfy the principle of security, stability, reliability and economy. The rapid growth of receiving network load makes it necessary to determine the operation mode of power system to improve its adaptability to the power system planning as

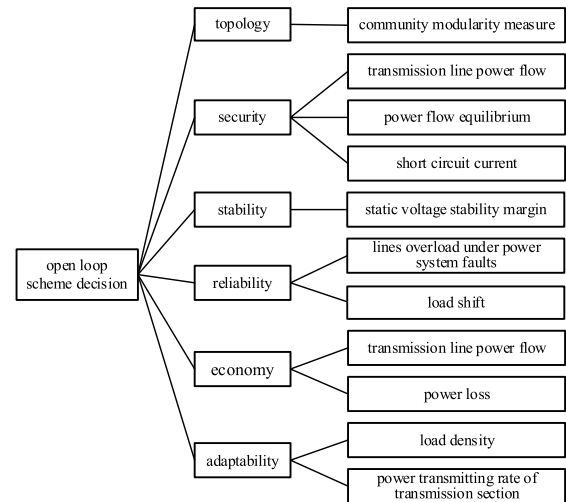

FIGURE 1. Evaluation index system of open loop operation mode of 500/200kV received electromagnetic looped grid.

much as possible. Based on those factors, this article has constructed the evaluation index system of open loop operation mode of 500/200kV received electromagnetic looped grid, as shown in Fig. 1.

A. INDEX OF THE COMMUNITY MODULARITY MEASURE

Complex community structure in networks refers to the formation of multiple nodes, which have the characteristics of close connections between the same community nodes and loose connections between nodes. In open loop operation mode of electromagnetic loop network, 220kV power system in different districts could be seen as a community. The more obvious the feature of the community structures that the power system topology shows, the more reasonable the open loop operation mode. In order to quantify the feature of the community structure, Newman and Girvan have put forward the concept of the community modularity measure [12], which is defined as the expectation of the ratio of edges connecting nodes within a community subtract edges connecting nodes of different communities. The mathematical equation is:

$$Q = \frac{1}{2m} \sum_{v=1}^n \sum_{\omega=1}^n \left(A_{v\omega} - \frac{k_v k_\omega}{2m} \right) \delta(c_v, c_\omega) \quad (1)$$

$$A_{v\omega} = \begin{cases} 1, & \text{node } v \text{ and node } \omega \text{ connect} \\ 0, & \text{node } v \text{ and node } \omega \text{ disconnect} \end{cases} \quad (2)$$

$$\delta(c_v, c_\omega) = \begin{cases} 1, & \text{node } v \text{ and node } \omega \text{ in same community} \\ 0, & \text{node } v \text{ and node } \omega \text{ in different community} \end{cases} \quad (3)$$

In (1), n is the number of nodes in the network. m is the number of total edges in the network. k_v, k_ω are the number of nodes connected to node v, ω respectively. The range of Q is $[0, 1]$, which is closer to 1 as the community is divided more reasonable.

B. INDEX OF THE TRANSMISSION LINE POWER FLOW

By opening and closing 220kV transmission lines, different open loop operation modes lead to the differences in power flow. Therefore, load of transmission lines is unable to keep in the ideal interval. If it is too low, there will be the drawbacks of redundant transmission capacity and waste of power grid construction investment. If it is too high, there will be a risk of overload, which cannot guarantee the safe and stable operation of the power grid. Considering those factors, setting modifying coefficients for different load rate when setting up 220kV lines index of power flow, so that the more lines with load rates in the ideal range, the smaller the index value. The calculation equation of 220kV transmission line power flow index L_{cur} is:

$$L_{cur} = \frac{1}{n_1} \left(\sum_{i=1}^{n_1} \alpha_l \frac{I_{li}}{I_{li,lim}} \right) + \frac{1}{n_2} \left[\sum_{j=1}^{n_2} \alpha_l \left(1 - \frac{I_{lj}}{I_{lj,lim}} \right) \right] + \frac{1}{n_3} \left(\sum_{j=1}^{n_3} \beta_l \frac{I_{lk}}{I_{lj,lim}} \right) \quad (4)$$

In (4), I is the value of current. I_{lim} is the limit value of thermal stability. $I_{thr.min}$, $I_{thr.max}$ represent the minimum threshold and maximum threshold of the current respectively. n_1 , n_2 , n_3 represent the number of lines over maximum threshold, lower than minimum threshold, within the interval respectively. α_l is the modifying coefficient when the thresholds are exceeded, which equals to 0.7 if $I_l/I_{l,lim} < I_{thr.min}$ or $I_l/I_{l,lim} > I_{thr.max}$, otherwise, equals to 0.3.

C. INDEX OF POWER FLOW EQUILIBRIUM

Power flow equilibrium is able to embody the validity of power system supply, load distribution and equipment layout. Under different open operation modes, although the load rate of 500kV transformer can be kept in a reasonable interval after expanding capacity, power flow equilibrium is of great difference. According to the weighted entropy put forward by the paper [23], index of power flow equilibrium is set up combined with the supply mode that 220kV receiving grid is energized by several 500kV transformers when 500/200kV received electromagnetic looped grid is in open operation mode.

Image the rated power of the transformer is $S_{i,lim}$, actual power is S_i , and load rate φ_i is:

$$\varphi_i = \frac{S_i}{S_{i,lim}} \quad (5)$$

Under normal operating condition, the range of the load rate is $[0, 1]$, and the load rate of the interval k is $(\varphi_{k-1}, \varphi_k]$ when the interval is divided into 10 equal parts. T_k stands for the number of transformers whose load rate is in the interval k . $P(k)$ is probability which transformer load rate is in $(\varphi_{k-1}, \varphi_k]$, and $W(k)$ is average load rate which transformer load rate is in $(\varphi_{k-1}, \varphi_k]$.

$$P(k) = T_k / \sum_{k=1}^{10} T_k \quad (6)$$

$$W(k) = \sum_{i=1}^{T_k} \varphi_i / T_k \quad (7)$$

According to the definition of weighted entropy, (6), and (7), define H_T , the index of power flow equilibrium as:

$$H_T = - \sum_{k=1}^{10} W(k) P(k) \ln P(k) \quad (8)$$

D. INDEX OF SHORT CIRCUIT CURRENT

The open loop operation mode of electromagnetic loop network can solve the problem that electrical connection is excessively tight essentially, thereby limiting the short circuit current. To embody the influence of short circuit current on security margin, 220kV bus short circuit current is divided into different intervals by the value according to the actual short circuit current, and different modifying coefficients are set for different levels. Therefore, establish I_{SC} , the index of short circuit current:

$$I_{SC} = \sum_{i=1}^N \frac{\delta_i}{g_i} \left(\sum_{j=1}^{g_i} \frac{I_{kj}}{I_{kN}} \right) \quad (9)$$

In (9), N is the number of short circuit current intervals. δ_i , g_i are the modifying coefficient and the number of buses respectively when the short circuit current is in the interval i . I_{kj} , I_{kN} are short circuit current and cut-off current of 220kV buses respectively.

E. INDEX OF STATIC VOLTAGE STABILITY MARGIN

The ever-growing load cause power system to its extreme state and the problem of voltage stability has gradually become the reason for the occurrence and development of blackouts [24]. The distance of running point to instable point is characterized by stable voltage margin, in order to judge the state of power system. The equation is:

$$K_p = \frac{P_{max} - P_i}{P_{max}} \times 100\% \quad (10)$$

In (10), P_{max} is the load of maximum transport state and P_i is the load of current state.

F. INDEX OF LINES OVERLOAD UNDER POWER SYSTEM FAULTS

In the open loop operation mode of electromagnetic loop network, under normal or 500kV main transformer maintenance condition, N-1 or N-2 fault of 220kV transmission lines may cause overload and different faults will lead to different risks. The evaluation of probability reliability [11] has considered the possibility and seriousness of accident occurrence to establish quantifying index. The equation is:

$$R_1 = \sum_{i=1}^{n_F} \sum_{j=1}^{n_l} h_i \gamma_{ij} \left(\frac{I_{ij}}{I_{ij,lim}} - 1 \right) \quad (11)$$

In (11), n_F is the number of all faults. h_i is the probability of the fault i , which is defined as the ratio of annual fault-lasting time and annual utilization hours. I_{ij} is the current of

line j when fault i happens. $I_{ij.lim}$ is the limit value of thermal stability of line j . If any line is overload when fault i happens, $\gamma_{ij} = 1$, otherwise, $\gamma_{ij} = 0$.

G. INDEX OF LOAD SHIFT

When the fault of critical lines happens or fault happens under maintenance condition, supply ability may not satisfy the load demand limited by thermal stability of equipment. In order to avoid severe overload, load shift measure is needed to lower the load rate of equipment. The calculation equation of load shift index is:

$$R_2 = \frac{\sum_{i=1}^{n_F} h_i P_{int.i}}{P_{load}} \tag{12}$$

In (12), n_F is the number of all faults. $P_{int.i}$ is the value of load shift when fault i happens. P_{load} is load of power system.

H. INDEX OF POWER LOSS

Power loss is a common economy index to assess the operation status of power system. Define P_{loss} , the power loss, as

$$P_{loss} = \frac{\Delta P_{loss}}{\Delta P_{loss} + P_{load}} \tag{13}$$

where ΔP_{loss} is power loss. P_{load} is load of power system.

I. INDEX OF LOAD DENSITY

Load density is an average value of power used per square kilometer to characterize the density of load distribution. The area, load and power plant distribution within the district of 220kV regional power system after open loop of receiving electromagnetic loop network vary along with the open loop operation mode, thus, define index of load density P_ρ as

$$P_\rho = \sum_{i \in B} \frac{P_{loadi} - P_{Gi}}{A_{cri}} \tag{14}$$

where B is the set of 220kV regional power system. P_{loadi} , P_{Gi} , A_{cri} are the load, plants' power and area of the 220kV regional power system.

J. INDEX OF POWER TRANSMITTING RANGE OF TRANSMISSION SECTION

The transmission section is a set of 220kV outgoing lines of receiving power system's 500kV substations, which supplies power to load. The transmitting power of the transmission section has a great sensitivity to the change of load. The sensitivity of transmitting power is influenced by network parameters, topology structure and the variety of power flow, which are settled if the operation mode of power system is settled and make the sensitivity of transmitting power be a fixed value [25]. Therefore, power sensitivity could be calculated by the rate of power variation under different open loop modes:

$$G_k = \frac{\Delta P_k}{\Delta P_{load}} \tag{15}$$

In (15), G_k is the power sensitivity of the line k in the transmission section; ΔP_k is the power variation of the line k ; ΔP_{load} is the variation of load.

Under different open loop modes, network parameters, topology structure and the variety of power flow will change, leading to the change of the power sensitivity of transmission section. Define the index of power transmitting rate of transmission section as the ratio of total power sensitivity and power transmitting margin. When the load growth is same, the lower the index is, the lower the possibility of the transmission section overload under a specific open loop operation mode is and the better to meet the load growth. The calculation equation is:

$$T_p = \frac{\left(\sum_{k \in D} G_k\right) P_{S,max}}{P_{S,max} - P_S} \tag{16}$$

In (16), D is the set of lines of the transmission section. $P_{S,max}$ is the power transmitting limit of the transmission section. P_S is the actual transmitting power of the transmission section.

III. APPROACH OF DETERMINING CONSTANT WIGHTH OF INDEX

A. CONSISTENT PROCESSING OF INDEX

In the evaluation index of open loop operation mode of 500/200kV received electromagnetic looped grid, the larger of the index value of the community modularity measure and the static voltage stability margin are, the better operation of the power grid will be. This type of index is called "benefit type index". On the contrary, the smaller the index value of eight indexes including the line power flow, power flow equilibrium, short circuit current, *et al.* are, the better the operation of the power grid will be. Such indexes are called "cost type index". In order to make the decision effect have consistent correlation with the value of each index, indexes need to be processed as the same property. Simultaneously, it is also necessary to avoid the change in the distribution law of the indicators caused by the same property processing, which affects the accuracy of the decision results. This article uses the method of differential inverse transformation on the "benefit type index" to process the index consistently:

$$x'_{ij} = \begin{cases} 1 - x_{ij}, & x_{ij} \text{ is "benefit type index"} \\ x_{ij}, & x_{ij} \text{ is "cost type index"} \end{cases} \tag{17}$$

In (17), x_{ij} is the original index value, x'_{ij} is the index value after the consistent processing. In case, there are p schemes to be decided and q evaluation indexes, then, $i = 1, 2, \dots, p, j = 1, 2, \dots, q$. After the consistent processing, the evaluation index vector of the scheme i to be decided is $X'_i = [x'_{i1}, x'_{i2}, \dots, x'_{iq}]$, and the evaluation matrix is $X' = [X'_1, X'_2, \dots, X'_i, \dots, X'_p]^T = (x'_{ij})_{p \times q}$. In this article, there are 10 evaluation indexes, so $q = 10$, which corresponding to the community modularity measure, the transmission line power flow, power flow equilibrium, short circuit current, static voltage stability margin, lines overload under power

system faults, load shift, power loss, load density and power transmitting rate of transmission section.

B. IMPROVED MAXIMUM DEVIATION WEIGHTING METHOD

For an index, if its values have small difference in different schemes, the index's degree of influence on the scheme assessing will be less. On the contrary, if the difference between index values are obvious, the index's degree of influence will be heavier. In order to improve the level of distinction between the schemes which to be decided, the indicators with obvious differences should be given bigger weight. Although the constant weight calculated by the maximum deviation weighting method in reference [26] satisfies the above requirements, the normalized attribute of the weight is not considered when constructing the objective function. In this regard, this article improves the weighting method based on the idea of maximizing deviation. The calculation steps are as follows:

(1) Standardization of index

The evaluation matrix X' which was obtained by consistent processing is standardized according to (18), and becomes standard evaluation matrix $X'' = (x''_{ij})_{p \times q}$.

$$x''_{ij} = \frac{x'_{ij}}{\sum_{i=1}^p x'_{ij}}, \quad (j = 1, 2, \dots, q) \quad (18)$$

In (18), x'_{ij} is the index value after the consistent processing.

(2) Calculate index deviation

For the evaluation index j , its deviation is calculated by (19):

$$V_j = \sum_{i=1}^p \sum_{k=1}^p |x''_{ij} - x''_{kj}| \quad (19)$$

In (19), x''_{ij} and x''_{kj} are the index values of the scheme i and the scheme k after the standardization.

(3) Calculate the constant weight

For maximizing deviation, if the deviation of an evaluation index increase, its wight will increase. So, the constant weight of an evaluation index j is the deviation of the index divided by the sum of the deviations of all indexes:

$$\omega_j = \frac{V_j}{\sum_{j=1}^q V_j} \quad (20)$$

It can be verified that the index constant weights satisfy normalization and their value range is in the range of 0 to 1. The constant weight is determined completely based on objective data and mathematical methods, which avoiding the subjective preference and randomness of the weight.

IV. INCENTIVE-TYPE VARIABLE WEIGHT MULTI-ATTRIBUTE DECISION MODEL

Constant weight only reflects the importance of indexes in the decision-making process through the difference of index

values in different schemes which to be decided, without considering the impact of each index value's change trend in the same scheme on the decision results. For complex problems, the decision conclusions will be on the contrary to the actual situation. In order to avoid conclusion errors, an incentive-type variable weight multi-attribute decision model is established according to the variable weight theory. Incentive variable weight is a mapping, that is, through the variable weight function, each index value has its unique corresponding weight. Compared with the constant weight, the weight of each index in every scheme is no longer fixed. So, this kind of weight is called variable weight. This mapping needs to meet the following three principles [27]:

1) The sum of the variable weights of each index in every scheme is 1;

2) The constructed variable weight function is a continuous function;

3) The constructed variable weight function is monotonous and monotonously increasing.

According to the definition and principles of the incentive-type variable weight, the second power variable weight function is constructed as shown in (21):

$$\omega'_{ij} = \frac{\omega_j x''_{ij}{}^2}{\sum_{j=1}^q \omega_j x''_{ij}{}^2} \quad (21)$$

In (21), ω'_{ij} is the variable weight, ω_j is the constant weight obtained by (20); x''_{ij} is the index value in the standard evaluation matrix.

The comprehensive score $E(i)$ of each scheme to be decided can be calculated according to (22).

$$E(i) = \sum_{j=1}^q \omega'_{ij} \times x''_{ij} \quad (22)$$

In this article, the evaluation index of open loop operation mode of 500/200kV received electromagnetic looped grid has been processed consistently as "cost type index". Therefore, the open loop scheme with the smallest score has the best operating status.

V. EXAMPLE ANALYSIS

The open loop schemes of actual 500/200kV received electromagnetic looped grid are compared and analyzed based on the evaluation index system and the incentive-type variable weight multi-attribute decision model. Fig. 2 shows the network structure of the actual power grid. In the receiving-end power grid, there are four 500kV substations A-D, and eight 500kV transformers in these substations. There are twenty-six 220kV substations S1-S26 and 5 power plants whose installed capacity is 2415MW. The total load of the received power grid is 5372MW.

After the 500kV network is completed and put into operation, the 500/200kV electromagnetic looped grid formed during the construction process has seriously restricted the safe and stable operation of the grid. In order to realize the decomposing operation and ensure the reliable power supply

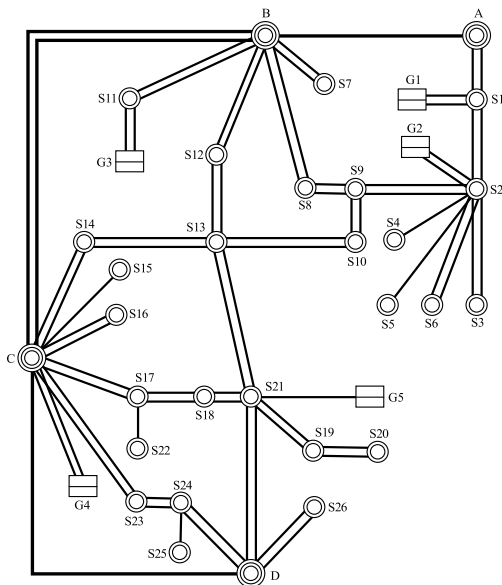

FIGURE 2. Network structure of the actual power grid.

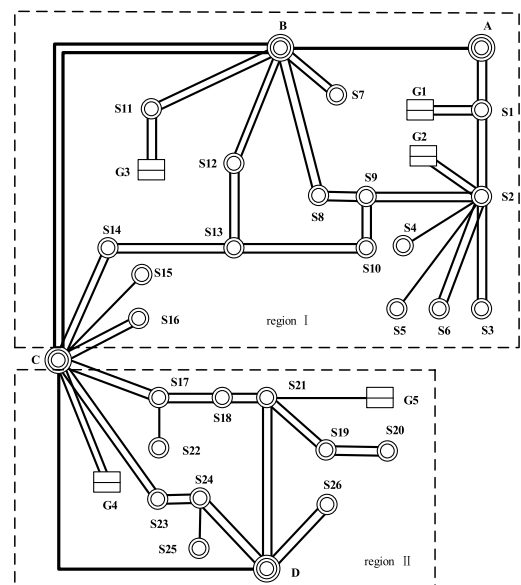

FIGURE 4. Network structure of open loop scheme II.

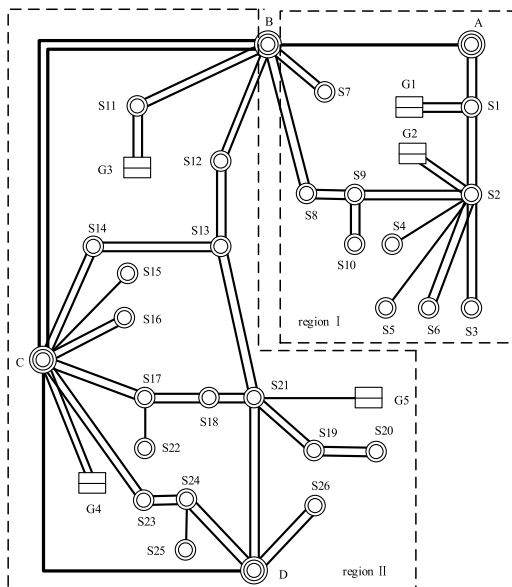

FIGURE 3. Network structure of open loop scheme I.

of the load, at this stage, two open loop schemes can be implemented by breaking transmission line which connects substation 10 and substation 13 or the transmission line which connects substation 13 and substation 21. The network structure after open loop is shown in fig. 3 and fig. 4.

The power grid is divided into two different 220kV regional power grids when the loop is opened, and their topological structures are different. According to the definition of evaluation indexes, set $I_{thr.min}$ and $I_{thr.max}$ are set to 25% and 75% respectively in this example. The interrupting current of 220kV circuit breaker is 50 kA, so the short circuit current is divided into three sections: (45,50), (40,45] and (0,40), and the correction coefficients are 0.6, 0.4, 0.2 respectively. Set the operating condition of the power grid to summer heavy load and full power generation of

the power plant, power system analysis software tools (PSD Power Tools) are used to simulate the power grid operation. Evaluation index values are calculated by (1)-(16), and then the standard evaluation matrix $X''_{2 \times 10}$ is formed by consistent and standardized processing:

$$X''_{2 \times 10} = \begin{bmatrix} 0.5247 & 0.4902 & 0.6056 & 0.6098 & 0.5069 \\ 0.3839 & 0.5160 & 0.4824 & 0.5529 & 0.4672; \\ 0.4753 & 0.5098 & 0.3944 & 0.3902 & 0.4931 \\ 0.6161 & 0.4840 & 0.5176 & 0.4471 & 0.5328] \end{bmatrix}$$

Calculate the constant weight W_1 of indexes by (19) and (20):

$$W_1 = \begin{bmatrix} 0.050 & 0.020 & 0.215 & 0.223 & 0.014 \\ 0.236 & 0.032 & 0.036 & 0.107 & 0.067] \end{bmatrix}$$

Bring standardized index values and constant weights into (21) to obtain the incentive-type variable weight W_2 :

$$W_2 = \begin{bmatrix} 0.049 & 0.017 & 0.278 & 0.293 & 0.013 \\ 0.123 & 0.031 & 0.029 & 0.116 & 0.051; \\ 0.048 & 0.022 & 0.142 & 0.145 & 0.015 \\ 0.382 & 0.032 & 0.041 & 0.092 & 0.081] \end{bmatrix}$$

It can be seen that each index value has a unique weight to correspond. Substituting the index values and variable weights into (22), the comprehensive score of the open loop scheme I is 0.553, and the comprehensive score of the open loop scheme II is 0.510. Therefore, the whole characteristic of the 500/220kV received electromagnetic looped grid after decomposing is better in open loop scheme II than that in open loop scheme I.

The Delphi method and the coefficient of variation method are used to evaluate the two open loop schemes to demonstrate the accuracy and effectiveness of the conclusions which are obtained by incentive-type variable weight multi-attribute decision model. The results are shown in tab. 1.

The comprehensive scores of two open loop schemes obtained according to the Delphi method are almost the same, so the accurate decision results cannot be made. That is

TABLE 1. Index weights and scheme scores of different decision methods.

decision method		index eight										score
		Q	L_{cur}	H_T	I_{SC}	K_p	R_1	R_2	P_{loss}	P_p	T_P	
Delphi method	Scheme I	0.048	0.152	0.098	0.106	0.084	0.166	0.148	0.099	0.047	0.052	0.504
	Scheme II											0.496
coefficient of variation method	Scheme I	0.071	0.032	0.172	0.176	0.016	0.264	0.040	0.032	0.109	0.088	0.511
	Scheme II											0.489
incentive-type variable weight	Scheme I	0.049	0.017	0.278	0.293	0.013	0.123	0.031	0.029	0.116	0.051	0.553
	Scheme II	0.048	0.022	0.142	0.145	0.015	0.382	0.032	0.041	0.092	0.081	0.510

because the Delphi method is completely based on subjective willingness to assign weights to the index. When there are various evaluation indexes, it is impossible to calculate the weights by referring to the change law of the index values, which bring errors to decision conclusions. Both the coefficient of variation method and the incentive-type variable weight multi-attribute decision model can ensure the objectivity of the weights and the decision conclusions are consistent, scheme II is better than scheme I. However, the incentive-type variable weight multi-attribute decision model further highlights the advantages and disadvantages of the schemes by adjusting the constant weights, and achieves a more accurate decision conclusion.

Through the simulation, the highest bus short circuit current is 45.083 kA in the scheme I, and 44.078 kA in scheme II, and the whole short circuit current level of the scheme II is lower than that of scheme I. When the power grid is operating in the scheme II, the load rate of eight 500 kV transformers is concentrated between 40%-50%. While the load rate of eight 500 kV transformers is 63.3% at the highest and 30.8% at the lowest in scheme I, the load rate of scheme I is more discrete. After changing the weights, the index weights of the power flow equilibrium and short circuit current in the scheme I are changed from 0.215 and 0.223 to 0.278 and 0.293 respectively, which increases the comprehensive score of this scheme. It is obvious that incentive-type variable weight multi-attribute decision model avoids the problem of decision failure and improves the accuracy and effectiveness of decision conclusions.

VI. CONCLUSION

The decomposed 500/220kV received electromagnetic looped grid evaluation index established in this article, which comprehensively considering topology structure, power grid operation security, power supply reliability, economy and planning adaptability, can quantitatively describe the overall characteristics of the power grid. In terms of constant weight decision shortage, incentive-type variable weight multi-attribute decision model is raised by various weight theory. The accuracy and effectiveness of the conclusion obtained by this decision model is verified

by real decomposed 500/220kV electromagnetic looped grid case. Consequently, the proposed evaluation index and decision model can provide technology reference and enhance efficiency when electromagnetic looped grid has to decompose. Meanwhile, incentive-type variable weight multi-attribute decision model proposed in this article can avoid decision failure, and finally promote decision effect, which can be applied in different engineering complex decision problem domain.

REFERENCES

- [1] Y. Dong, X. Xie, B. Zhou, W. Shi, and Q. Jiang, "An integrated high side var-voltage control strategy to improve short-term voltage stability of receiving-end power systems," *IEEE Trans. Power Syst.*, vol. 31, no. 3, pp. 2105–2115, May 2016, doi: [10.1109/TPWRS.2015.2464695](https://doi.org/10.1109/TPWRS.2015.2464695).
- [2] G. Li, X. R. Liu, and J. B. Sun, "Characteristics and case analysis of extra-high voltage electromagnetic loop networks," *Autom. Electr. Power Syst.*, vol. 41, no. 6, pp. 147–153, May 2017, doi: [10.7500/AEPS20160522008](https://doi.org/10.7500/AEPS20160522008).
- [3] X. J. Tang, Y. Xie, H. M. Luo, L. Cheng, S. J. Cao, and Y. Cao, "Assessment method and instance of provincial grid adaptation after UHV line connection," *Power Syst. Technol.*, vol. 41, no. 5, pp. 1476–1483, May 2017, doi: [10.13335/j.1000-3673.pst.2016.2896](https://doi.org/10.13335/j.1000-3673.pst.2016.2896).
- [4] Y. Tang, G. Q. Bu, and J. Yi, "Analysis and lessons of the blackout in Indian power grid on July 30 and 31, 2012," *Proc. CSEE*, vol. 35, no. 25, pp. 167–174, Sep. 2012, doi: [10.13334/j.0258-8013.psee.2012.25.012](https://doi.org/10.13334/j.0258-8013.psee.2012.25.012).
- [5] Y. Liu, "Analysis on out-of-step separation in Brazilian power grid and its inspiration," *Power Syst. Technol.*, vol. 43, no. 4, pp. 1111–1121, Apr. 2019, doi: [10.13335/j.1000-3673.pst.2019.0018](https://doi.org/10.13335/j.1000-3673.pst.2019.0018).
- [6] A. A. Razi-Kazemi, M. Vakilian, K. Niayesh, and M. Lehtonen, "Priority assessment of online monitoring investment for power system circuit breakers—Part I: Qualitative-quantitative approach," *IEEE Trans. Power Del.*, vol. 28, no. 2, pp. 928–938, Apr. 2013, doi: [10.1109/TPWRD.2013.2243921](https://doi.org/10.1109/TPWRD.2013.2243921).
- [7] X. Jin, W. Qiao, Y. Peng, F. Cheng, and L. Qu, "Quantitative evaluation of wind turbine faults under variable operational conditions," *IEEE Trans. Ind. Appl.*, vol. 52, no. 3, pp. 2061–2069, May 2016, doi: [10.1109/TIA.2016.2519412](https://doi.org/10.1109/TIA.2016.2519412).
- [8] Y. Yang and Z. Guo, "Sufficient condition for the parallel flow problem of electromagnetic loop networks," *Math. Problems Eng.*, vol. 2018, no. 3, pp. 1–8, 2018, doi: [10.1155/2018/8192710](https://doi.org/10.1155/2018/8192710).
- [9] H. Wu, L. Yuan, L. Sun, and X. Li, "Modeling of current-limiting circuit breakers for the calculation of short-circuit current," *IEEE Trans. Power Del.*, vol. 30, no. 2, pp. 652–656, Apr. 2015, doi: [10.1109/TPWRD.2014.2305166](https://doi.org/10.1109/TPWRD.2014.2305166).
- [10] F. Hu, K. Sun, D. Shi, and Z. Wang, "Measurement-based voltage stability assessment for load areas addressing $n - 1$ contingencies," *IET Gener., Transmiss. Distrib.*, vol. 11, no. 15, pp. 3731–3738, Oct. 2017, doi: [10.1049/iet-gtd.2016.1913](https://doi.org/10.1049/iet-gtd.2016.1913).
- [11] Y. Wang, V. Vittal, M. Abdi-Khorsand, and C. Singh, "Probabilistic reliability evaluation including adequacy and dynamic security assessment," *IEEE Trans. Power Syst.*, vol. 35, no. 1, pp. 551–559, Jan. 2020, doi: [10.1109/TPWRS.2019.2923844](https://doi.org/10.1109/TPWRS.2019.2923844).

- [12] M. E. J. Newman and M. Girvan, "Finding and evaluating community structure in networks," *Phys. Rev. E, Stat. Phys. Plasmas Fluids Relat. Interdiscip. Top.*, vol. 69, no. 2, pp. 1–15, Feb. 2004, doi: [10.1103/PhysRevE.69.026113](https://doi.org/10.1103/PhysRevE.69.026113).
- [13] D. Wu, N. Zhang, C. Kang, Y. Ge, Z. Xie, and J. Huang, "Techno-economic analysis of contingency reserve allocation scheme for combined UHV DC and AC receiving-end power system," *CSEE J. Power Energy Syst.*, vol. 2, no. 2, pp. 62–70, Jun. 2016, doi: [10.17775/CSEEJPES.2016.00023](https://doi.org/10.17775/CSEEJPES.2016.00023).
- [14] L. Zhu, D. Chen, J. Zhang, and Q. Li, "Dynamic equivalent scheme for main grid of China Southern power grid considering feature constraints," *Electr. Power Autom. Equip.*, vol. 39, no. 9, pp. 206–212, Sep. 2019, doi: [10.16081/j.epae.201909008](https://doi.org/10.16081/j.epae.201909008).
- [15] P. Xu, S. C. Yang, F. Li, S. H. Feng, K. Wang, and F. Shi, "Power grid security index calculation and display method based on AHP and variable weight mechanism," *Autom. Electr. Power Syst.*, vol. 39, no. 8, pp. 133–140, Apr. 2015, doi: [10.7500/AEPS20140728014](https://doi.org/10.7500/AEPS20140728014).
- [16] W. H. Middendorf, "A modified delphi method of solving business problems," *IEEE Trans. Eng. Manag.*, vol. EM-20, no. 4, pp. 130–133, Nov. 1973, doi: [10.1109/TEM.1973.6448448](https://doi.org/10.1109/TEM.1973.6448448).
- [17] G. Tian, H. Zhang, M. Zhou, and Z. Li, "AHP, gray correlation, and TOPSIS combined approach to green performance evaluation of design alternatives," *IEEE Trans. Syst., Man, Cybern. Syst.*, vol. 48, no. 7, pp. 1093–1105, Jul. 2018, doi: [10.1109/TSMC.2016.2640179](https://doi.org/10.1109/TSMC.2016.2640179).
- [18] K. K. Anaparthi, B. Chaudhuri, N. F. Thornhill, and B. C. Pal, "Coherency identification in power systems through principal component analysis," *IEEE Trans. Power Syst.*, vol. 20, no. 3, pp. 1658–1660, Aug. 2005, doi: [10.1109/TPWRS.2005.852092](https://doi.org/10.1109/TPWRS.2005.852092).
- [19] J. Liu, B. B. Zhang, and C. C. Zhao, "Data-driven based active power distribution algorithm in wing farm," *Autom. Electr. Power Syst.*, vol. 43, no. 17, pp. 125–131, Sep. 2019, doi: [10.7500/AEPS20190110004](https://doi.org/10.7500/AEPS20190110004).
- [20] X. Chen, X. Xu, J. Z. Huang, and Y. Ye, "TW-k-means: Automated two-level variable weighting clustering algorithm for multiview data," *IEEE Trans. Knowl. Data Eng.*, vol. 25, no. 4, pp. 932–944, Apr. 2013, doi: [10.1109/TKDE.2011.262](https://doi.org/10.1109/TKDE.2011.262).
- [21] R. H. Zou, Y. C. Wang, Y. J. Deng and K. Q. Xia, "Condition assessment method for transmission line with multiple outputs based on variable weight principle and fuzzy comprehensive evaluation," *High Voltage Eng.*, vol. 43, no. 4, pp. 1289–1295, Apr. 2017, doi: [10.13336/j.1003-6520.hve.20170328028](https://doi.org/10.13336/j.1003-6520.hve.20170328028).
- [22] L. Li, L. J. Xie, D. Zhang, B. Yu, Y. F. Ge and F. H. Lin, "Condition assessment of power transformers using a synthetic analysis method based on association rule and variable weight coefficients," *IEEE Trans. Dielectr. Electr. Insul.*, vol. 20, no. 6, pp. 2052–2060, Dec. 2013, doi: [10.1109/TDEI.2013.6678853](https://doi.org/10.1109/TDEI.2013.6678853).
- [23] X. Qu, H. Chen, and G. Peng, "Novel detection method for infrared small targets using weighted information entropy," *J. Syst. Eng. Electron.*, vol. 23, no. 6, pp. 838–842, Dec. 2012, doi: [10.1109/JSEE.2012.00102](https://doi.org/10.1109/JSEE.2012.00102).
- [24] Y. Xue, T. Xu, B. Liu, and Y. Li, "Quantitative assessments for transient voltage security," *IEEE Trans. Power Syst.*, vol. 15, no. 3, pp. 1077–1083, Aug. 2000, doi: [10.1109/59.871736](https://doi.org/10.1109/59.871736).
- [25] Y. Xu and J. Zhi, "Directional control of the cut set interface power based on power sensitivity and generator Re-dispatch," *Power Syst. Technol.*, vol. 39, no. 8, pp. 2258–2263, Aug. 2015, doi: [10.13335/j.1000-3673.pst.2015.08.029](https://doi.org/10.13335/j.1000-3673.pst.2015.08.029).
- [26] J. K. Li, H. Teng, and N. Guo, "An optimal decision to restrain short circuit current for 500 kV power grids with combinatorial weighting method of relative entropy," *Power Syst. Technol.*, vol. 40, no. 6, pp. 1811–1817, Jun. 2016, doi: [10.13335/j.1000-3673.pst.2016.06.030](https://doi.org/10.13335/j.1000-3673.pst.2016.06.030).
- [27] G.-F. Yu, W. Fei, and D.-F. Li, "A compromise-typed variable weight decision method for hybrid multiattribute decision making," *IEEE Trans. Fuzzy Syst.*, vol. 27, no. 5, pp. 861–872, May 2019, doi: [10.1109/TFUZZ.2018.2880705](https://doi.org/10.1109/TFUZZ.2018.2880705).



HAIYUN WANG was born in Huanan, Heilongjiang, China, in 1988. She received the B.S. degree in power systems and automation from North China Electric Power University, Beijing, China, in 2010, and the M.S. degree in power systems from the University of Strathclyde, U.K., in 2011.

She is currently a Senior Engineer at Beijing Electric Power Company. Her research interests include large power grid operation and control and loss analysis.



ZHIJIAN ZHANG was born in Beijing, China, in 1974. She received the M.S. degree from North China Electric Power University, Beijing, in 2001. She is currently a Senior Engineer at Beijing Electric Power Company. Her research interests include large power grid operation and automation.

JINYANG DONG was born in Hebei, China, in 1986. He received the M.S. degree in electrical engineering from Tsinghua University, in 2011.

He is currently a Senior Engineer with the Electric Power Research Institute, State Grid Beijing Electric Power Company. His research interests include large power grid operation and large power grid planning technology.



YUXUAN ZHANG was born in Beijing, China, in 1993. She received the B.S. degree in electrical engineering from North China Electric Power University, Beijing, in 2015, and the M.S. degree in electrical engineering from The University of Manchester, Manchester, U.K., in 2016.

She is currently an Intermediate Engineer with the Electric Power Research Institute, State Grid Beijing Electric Power Company. Her research interests include large power grid operation and control and large power grid planning technology.



HAO WU was born in Shuozhou, Shanxi, China, in 1997. He received the B.S. degree in electrical engineering and automation from Northeast Electric Power University, Jilin City, China, in 2018. He is currently pursuing the M.S. degree with the Taiyuan University of Technology, China. His research interest includes power system operation and control.



WENCHAO ZHANG was born in Baoding, Hebei, China, in 1978. He received the B.S. degree in electrical engineering and the M.S. and Ph.D. degrees in power systems and automation from North China Electric Power University, Baoding, in 1999, 2002, and 2016, respectively.

He is currently a Professorate Senior Engineer at Beijing Kedong Electric Power Control System Company Ltd. His research interests include large power grid operation and control and large power grid planning technology.

• • •