

Received June 26, 2020, accepted July 21, 2020, date of publication July 27, 2020, date of current version August 7, 2020.

Digital Object Identifier 10.1109/ACCESS.2020.3012006

A New Frontier for IoT Security Emerging From Three Decades of Key Generation Relying on Wireless Channels

JUNQING ZHANG¹, GUYUE LI^{2,4}, (Member, IEEE),
ALAN MARSHALL¹, (Senior Member, IEEE), AIQUN HU^{3,4}, (Member, IEEE),
AND LAJOS HANZO⁵, (Fellow, IEEE)

¹Department of Electrical Engineering and Electronics, University of Liverpool, Liverpool L69 3GJ, U.K.

²School of Cyber Science and Engineering, Southeast University, Nanjing 210096, China

³National Mobile Communications Research Laboratory, Southeast University, Nanjing 210096, China

⁴The Purple Mountain Laboratories for Network and Communication Security, Nanjing 210096, China

⁵School of Electronics and Computer Science, University of Southampton, Southampton SO17 1BJ, U.K.

Corresponding author: Lajos Hanzo (lh@ecs.soton.ac.uk)

The work of Junqing Zhang was supported by the Royal Society Research Grants under Grant ID RGS/R1/191241. The work of Guyue Li and Aiqun Hu was supported in part by the National Natural Science Foundation of China under Grant 61801115 and Grant 61941115 and in part by the Zhishan Youth Scholar Program of Southeast University under Grant 3209012002A3. The work of Lajos Hanzo was supported in part by the EPSRC projects under Grant EP/N004558/1 and Grant EP/P034284/1; in part by the Royal Society's GCRF Grant; and in part by the European Research Council's Advanced Fellow Grant QuantCom.

ABSTRACT The Internet of Things (IoT) is a transformative technology, which is revolutionizing our everyday life by connecting everyone and everything together. The massive number of devices are preferably connected wirelessly because of the easy installment and flexible deployment. However, the broadcast nature of the wireless medium makes the information accessible to everyone including malicious users, which should hence be protected by encryption. Unfortunately, the secure and efficient provision of cryptographic keys for low-cost IoT devices is challenging; weak keys have resulted in severe security breaches, as evidenced by numerous notorious cyberattacks. This paper provides a comprehensive survey of lightweight security solutions conceived for IoT, relying on key generation from wireless channels. We first introduce the key generation fundamentals and protocols. We then examine how to apply this emerging technique to secure IoT and demonstrate that key generation relying on the randomness of wireless channels is eminently suitable for IoT. This paper reviews the extensive research efforts in the areas of theoretical modelling, simulation based validation and experimental exploration. We finally discuss the hurdles and challenges that key generation is facing and suggest future work to make key generation a reliable and secure solution to safeguard the IoT.

INDEX TERMS Internet of Things, wireless security, physical layer security, key generation.

I. INTRODUCTION

A. MOTIVATION

The Internet of Things (IoT) integrates people, things and the environment. As illustrated in Fig. 1, IoT will transform our daily life with the aid of exciting new applications, including smart homes, e-commerce, connected healthcare and smart cities, to name but a few [1], [2]. Hence the IoT has attracted massive research and development interests from both academia and industry, given its significant impact

The associate editor coordinating the review of this manuscript and approving it for publication was Alessandra De Benedictis.

on the economy and society. McKinsey estimated that by 2025 there would be 25 billion to 50 billion devices and the potential economic impact would be in the range of \$3.9 to \$11.1 trillion per year [3].

There are many tiny low-cost devices in IoT applications, e.g. sensor nodes, Fitbit and implantable medical devices. They are usually powered by batteries, which may be difficult to replace. For example, many Long Range (LoRa) sensor nodes are designed to work for ten years with two AAA batteries. The limited size and power supply facilitate to provide "just" sufficient computational resources and storage spaces. IoT design has hence been mainly focused on reducing energy

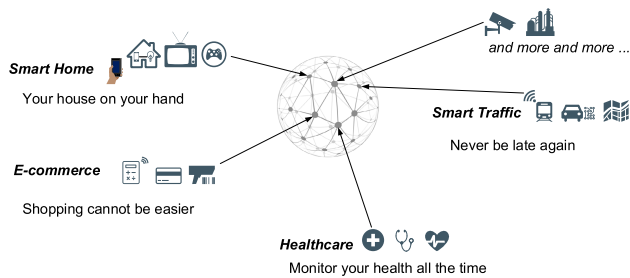

FIGURE 1. IoT applications.

and computational cost as well as improving the hardware efficiency. However, the security issues of the IoT have often been overlooked, treated as something “nice to have” rather than “must to have”.

On the other hand, the data transmitted in IoT applications can be sensitive, private and confidential, hence IoT security has significant societal and economic impacts. Healthcare devices and the data they generate are vital and private. For example, implantable devices such as a pacemaker are vital to patients’ life and their health-related data such as their heart rate is very private. Financial data should also be protected to the highest possible standard. Therefore, IoT security has been brought to the spotlight and has stimulated substantial research efforts [4]–[6].

Despite these efforts, there are still numerous security flaws and vulnerabilities [7], as evidenced by many notorious cyberattacks. Researchers have successfully hacked the latest generation of implantable medical devices using the widespread wireless devices referred to as the universal software radio peripheral (USRP) [8]. The automotive remote keyless entry system has also been cracked by very low-cost wireless modules (\$40), which exposes millions of cars to risk [9]. An implementation bug was found in the WiFi protected access (WPA) 2 [10], namely in the well-known WiFi encryption protocol, which affected almost everyone using smartphones and laptops.

In summary, the IoT is far from being secure, which is a major bottleneck on the road to trustworthy IoT applications. Numerous challenges arise because of the limited computational resources and energy supply. Hence, more research efforts should be invested in designing optimized security primitives, which are capable of providing tailored security for IoT applications.

B. WIRELESS SECURITY

1) A BRIEF HISTORY OF INFORMATION SECURITY

Information security can be mainly achieved by two approaches, namely *modern cryptography* and *physical layer security*. Cryptography protects information using mathematical algorithms and protocols. On the other hand, physical layer security techniques achieve information-theoretical security by exploiting the unpredictable features of the fading

channel. These techniques are summarized in Table 1 and will be introduced in detail.

Providing information security dates back to as early as 1919, when Venman proposed the “one-time pad” encryption of each message bit, by performing an exclusive-OR operation with different and truly random key bits [11]. In 1949, Shannon established the concept of perfect secrecy [12]. When the amount of information conveyed by the key sequence is higher than the information carried by the message, M , the message can be encoded into a codeword, C , which does not reveal any information about the message. This is formulated as

$$\mathbb{H}(M|C) = \mathbb{H}(M), \quad (1)$$

where $\mathbb{H}(\cdot)$ represents the entropy. However, because the keys cannot be reused at all, it is extremely challenging to provide a sufficiently high number of keys in an efficient manner.

Physical layer security research is pioneered by Wyner who presented his seminal work by designing the wiretap channel model in 1975 [13]. It is capable of achieving perfect secrecy without encrypting messages for transmission over a discrete memoryless channel, when the channel capacity of the legitimate channel is higher than that of the eavesdropping channel. His theory was then extended to the Gaussian wiretap channel in 1978 and the notion of secrecy capacity was defined [14]. Because no encryption is involved, these techniques are termed as keyless security in [15] and not affected by the computational capability of attackers. Wyner’s seminal work has inspired significant research efforts, dedicated to ensuring that the quality of the legitimate channel remains better than that of the eavesdropping channel (see [15]–[20] and references therein). This can be achieved for example by using artificial noise [21]–[24], beamforming [25]–[28] and on-off secure transmission [29]. However, keyless secure transmission usually requires complex code design and accurate channel state information (CSI) that may not be available. Additionally, having a better legitimate channel cannot always be guaranteed. Hence its practical applications remain rather limited at the time of writing.

As another design alternative, computational security achieved by modern cryptography has been one of the dominant information security solutions since the conception of the famous Diffie Hellman key exchange protocol in 1976 [30]. Cryptography does not achieve perfect secrecy, but it is capable of securing the information against attacks by using complex mathematical manipulations. Hence it is also often termed as computational security. Since cryptography imposes moderate complexity, it has become the *de facto* solution of securing information transmission. Depending on whether the two users have a pair of different keys or the same key, computational security-based schemes are termed as asymmetric and symmetric encryption [31]. In asymmetric encryption schemes, the parties have a pair of different public and private keys. The associated protocols are also known as public key cryptography (PKC). Relying on concepts inherited from number theory, such as discrete logarithm and

TABLE 1. Taxonomy of information security.

Security Route	Technique	Feature	Algorithm
Cryptography	Asymmetric Encryption (Public Key Cryptography)	Use same public key but different private keys; based on mathematical problems	Encryption: RSA Key distribution: Diffie Hellman key exchange Digital signature: ElGamal cryptosystem
	Symmetric Encryption	use the identical key at both users.	DES, RC4, AES
Physical Layer Security	Keyless Security Transmission	Confidential wireless transmission by employing the channel advantage	Beamforming, artificial noise
	Key Generation	Automatic key generation by leveraging unpredictable wireless fading	A four-stage protocol

integer factorization, PKC is eminently suitable for encryption such as Rivest–Shamir–Adleman (RSA) algorithm, key distribution such as Diffie Hellman key exchange and digital signatures such as ElGamal cryptosystem [31]. On the other hand, symmetric encryption schemes require the same key at both parties for encryption and decryption. The popular symmetric schemes include the RC4 (Section 7.5 of [31]), Data Encryption Standard (DES) [32] and the Advanced Encryption Standard (AES) [33], etc.¹

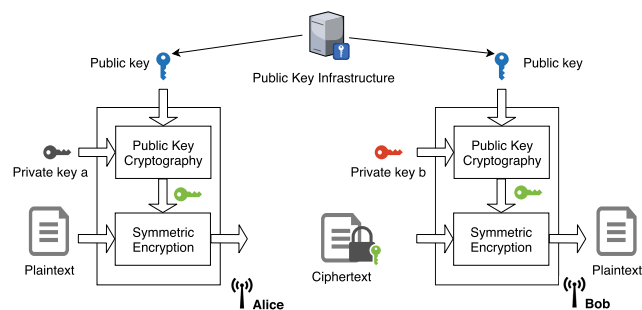

FIGURE 2. A classic encryption system. PKC distributes the same session key to Alice and Bob. They then use this session key for symmetric encryption to protect the data.

A classic encryption system is illustrated in Fig. 2, which includes key distribution by PKC and symmetric encryption. The public key infrastructure (PKI) first distributes the same public key to a pair of legitimate users, Alice and Bob. Alice and Bob have different private keys and they will be able to get the same session key based on some complex mathematical operations. The key is then used for the symmetric encryption to secure the transmissions.

2) CHALLENGES FOR IoT SECURITY

Since there is a huge number of IoT devices, wireless links are preferred for connecting these devices because of their convenient installation. There are many wireless IoT techniques, relying on cellular, IEEE 802.11/WiFi [34], IEEE 802.15.4 [35], Bluetooth [36], LoRa/LoRaWAN [37], Narrowband IoT (NB-IoT) [38], Sigfox [39] solutions, to name but a few.

The broadcast nature of wireless communications however exposes the information to all users within the communi-

cation range. Encryption is thus vital for ensuring message confidentiality and integrity. In particular, AES has been included in many IoT standards such as WiFi, IEEE 802.15.4, Bluetooth and LoRaWAN.

Taking LoRaWAN as an example. The latest LoRaWAN specification v1.1 [37] has defined a rigid security mechanism, as portrayed in Fig. 3. The end devices will be configured with the same network key, NwkKey and the same application key, AppKey, for the network and applications servers, respectively. These keys are used for generating the network session key and application session key to encrypt the payload using AES. While the LoRaWAN specification has explicitly defined the encryption mechanisms, unfortunately, it does not specify how to securely provide the cryptographic keys, namely NwkKey and AppKey. The LoRaWAN 1.1 specification states “secure provisioning, storage and usage of root keys NwkKey and AppKey on the end-device and the backend are intrinsic to the overall security of the solution. These are left to implementation and out of scope of this document.” (page 48 of [37]).

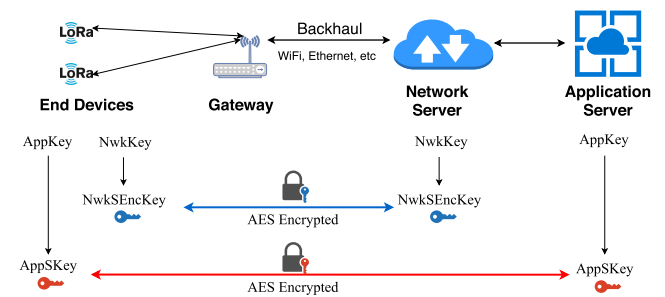

FIGURE 3. Security mechanism in the LoRaWAN protocol. AES is used to encrypt the network and application sessions. However, how to distribute the root keys, namely AppKey and NwkKey, is missing.

Similar to LoRaWAN, other IoT standards also refrain from specifying how to distribute keys for encryption to legitimate users. PKC is widely used in the Internet but may be challenged in the IoT context. Even though there exist lightweight implementations of PKC [40], e.g., TinyECC [41], NanoECC [42], some IoT devices still cannot afford the complexity. Many IoT devices have very limited computational resources and are powered by a battery. Additionally, PKI may not be readily available in device-to-device IoT communications. Finally, the security of cryptographic

¹RC4 and DES have been cracked, hence they are not used any more.

schemes, both symmetric encryption and PKC, are threatened by the emerging quantum computers [43]. Symmetric encryption can be enhanced by increasing the length of the keys; but PKC relies on complex mathematical algorithms that are not scalable, which will be broken by quantum computers [43].

Although neither secure nor efficient, pre-shared key is quite a common method for deploying keys for the IoT devices, as exemplified by programming keys into a device from a PC through a USB cable. However, it is challenging to update the keys for IoT devices once they are configured and deployed, given their huge population and typical locations.

Having a weak key/password will expose the entire network to risk and has indeed already resulted in serious cyberattacks [44]. As shown in Fig. 4, the Kaspersky Lab reported that there were more than 120,000 malware modifications during the first half of 2018, which is more than triple the amount in 2017 [45]. It is further revealed in the report that 93% of the attacks were caused by weak passwords. For example, “admin” is often used as the default password for many devices.

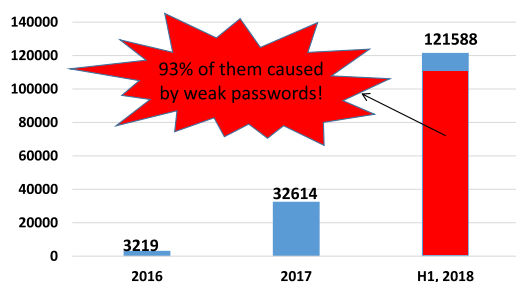

FIGURE 4. The number of IoT malwares. Data source: Kaspersky Lab [45].

Many IoT devices are eventually connected to the Internet, but they have become the “Achilles’ Heel” of the broad Internet network. The Dyn cyberattack is such a sad example, which occurred in the USA in October 2016 and affected millions of Internet users [44]. As illustrated in Fig. 5, the malware simply scanned all the connected IoT devices, including web cameras, building gateways, baby monitors, and tried a password for access. A massive number of devices were unfortunately configured with the default password and hacked. The Mirai malware then initialized a series of severe distributed denial of service (DDoS) attacks, which broke down the Dyn, the domain name system (DNS) provider in the USA. Internet services were thus disrupted and millions of Internet users were affected. Similarly, another DDoS attack was applied to the Philips smart lamps, which use ZigBee as the communication protocol [46]. The authors developed a novel side channel attack to deduce the global key that was used for each device type. Thus, the worm can be spread easily from an infected node to a bulb of the same type, because the same key was used.

In summary, the IoT and also the associated Internet are significantly threatened by the weak passwords of connected

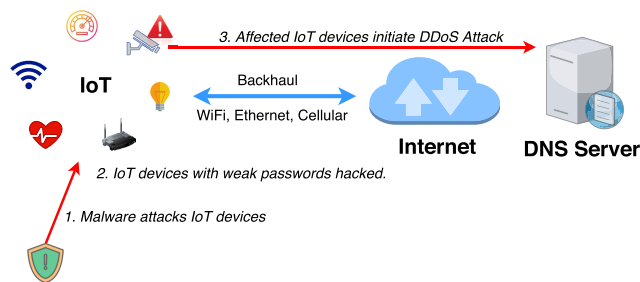

FIGURE 5. IoT cyberattacks. Connected IoT devices with weak password are compromised by the malware, which then results in severe DDoS attacks to the Internet.

devices. An efficient and lightweight key distribution scheme is urgently required for low-cost IoT devices.

C. KEY GENERATION

Apart from the above-mentioned security solutions, there is another popular technique of agreeing on a key extracted from wireless channels, which is termed as *secret key agreement*. Together with keyless security aided transmission, secret key agreement also falls under the umbrella of physical layer security, which achieves information-theoretical security by exploiting the unpredictable features of the random channel fading. Depending on the specific realization, secret key agreement has two models, namely the channel model and source model (Chapter 4 of [47]). The channel model-based key agreement operates similarly to the wiretap channel model, which intends to securely transmit keys from Alice to Bob, and agree on the same key via a two-way public channel [48]–[50]. However, it also faces the same challenges as keyless security in terms of its practical implementation.

The source model of secret key agreement works differently, namely by *generating* the keys from the wireless channel between Alice and Bob, rather than *transmitting* the keys, which is termed as *key generation from wireless channels*. The timeline is given in Fig. 6. The key generation philosophy dates back to 1993, when Ahlswede and Csiszar [51] and Maurer [52] laid down its information-theoretical foundations. Since then, the past three decades have witnessed the ever more sophisticated exploration of this promising technique. A practical key generation protocol was proposed in 1995 [53] and in 1996 [54]. There have been extensive interests on theoretical exploration [55], [56], modelling [57]–[61] and protocol design [62]–[65]. Thanks to the rapid development of the semiconductor industry and wireless technologies, wireless applications have become pervasive and lead to fruitful key generation prototyping and ultimately to its practical exploration. Key generation has then been applied to numerous wireless techniques, including IEEE 802.15.4/ZigBee (since 2005) [66]–[68], IEEE 802.11/WiFi (since 2008) [69]–[75], Bluetooth (since 2014) [76], LoRa/LoRaWAN (since 2018) [77]–[79].

The generated key can be used for one-time pad to achieve perfect secrecy, as explored in [80]. However, the key

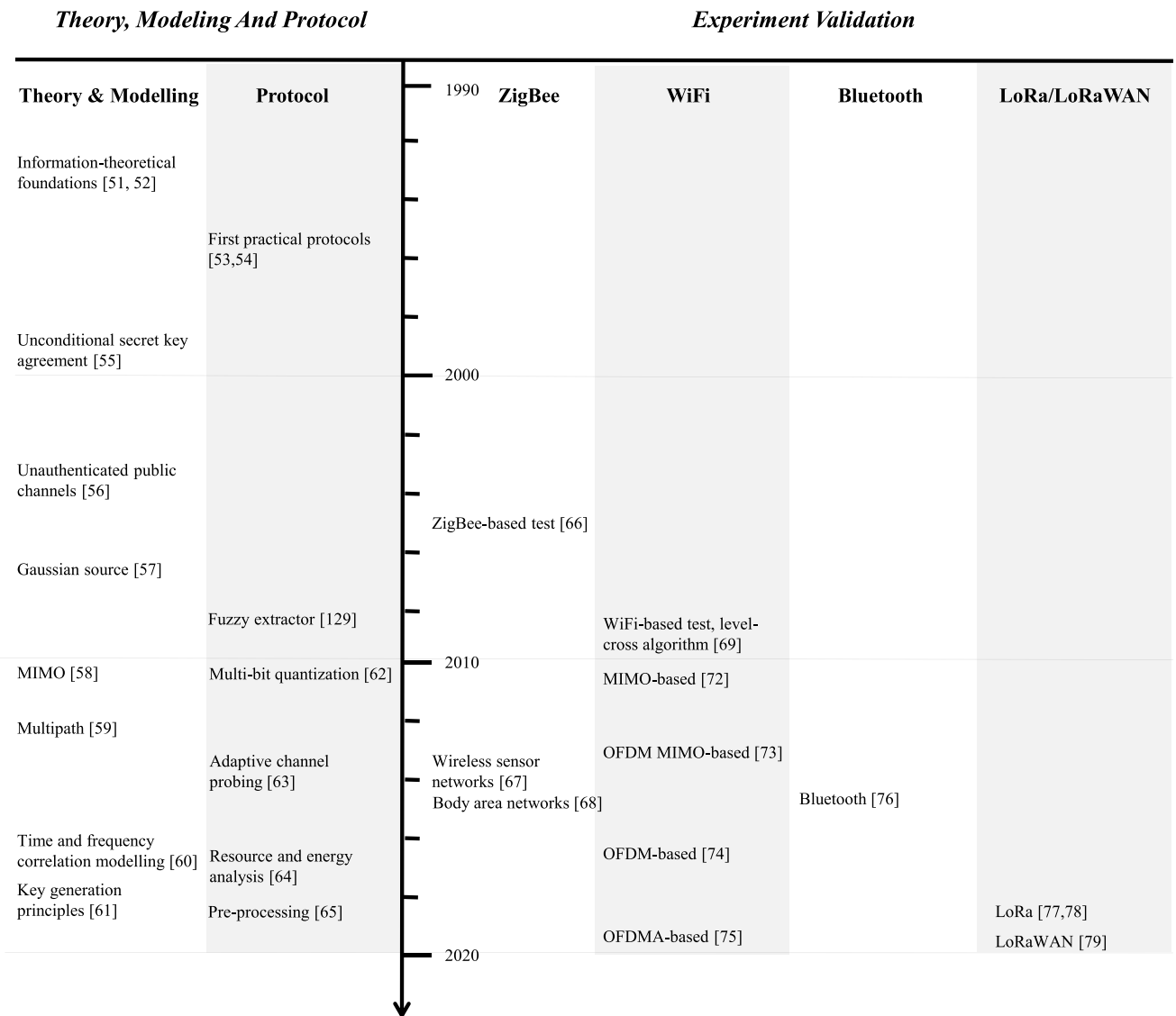

FIGURE 6. Timeline of key generation from wireless channels.

generation rate is not sufficiently high to support data communications. Hence, a more common application is constructing a hybrid cryptosystem using key generation and symmetric encryption, as shown in Fig. 7. Alice and Bob can generate the keys directly from their common wireless channel, without assistance from a third party, such as a PKI. Additionally, key generation is information-theoretically secure, hence it is not threatened by the emerging quantum computers. Finally, this technique is of lightweight nature, therefore it is eminently suitable for low-cost IoT devices. Therefore, key generation is an ideal alternative to PKC for the establishment of secure keys for the IoT.

This paper provides a comprehensive survey of random key generation from wireless channels. We introduce the key generation fundamentals, including the system modelling techniques and evaluation metrics. A full key generation protocol is proposed to exploit the common randomness of wireless channels between a pair of legitimate users. We then

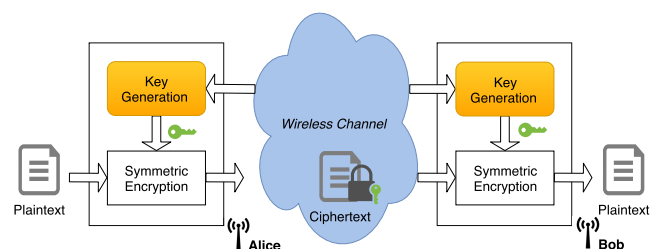

FIGURE 7. A key generation-based hybrid cryptosystem. Key generation establishes the same session key for Alice and Bob. They then use the key for symmetric encryption.

carefully review the associated design considerations of pairwise key generation by examining the channel parameters, signal domains, duplex modes and implementation aspects. We further extend the discussions from pairwise key generation to multiple players, which covers the multi-user and

cooperative key generation scenarios, as well as the associated security analysis. Finally, we review the scientific debate on this technique and identify a number of promising research directions. In a nutshell, we survey the entire suite of practical protocol designs and applications suitable for different wireless techniques and scenarios.

There have been several key generation surveys and tutorials published in [81]–[87]. A summary and comparison are given in Table 2. The most similar survey is the one that the authors published in 2016 [84]. This article significantly extends previous work by reviewing the exciting advances in the area since then.

D. ORGANIZATION

The rest of the article is organized as follows. Section II introduces the wireless IoT techniques. Key generation fundamentals, including random sources, principles, information-theoretic models and metrics, are covered in Section III. Section IV, Section V and Section VI review the family of key generation protocols, design considerations as well as their implementation and applications, respectively. Key generation designed for multiple parties/nodes is discussed in Section VII. Section VIII briefly introduces device authentication, conceived for ascertaining the identity of key generation parties. Section IX suggests future research while Section X concludes the article. The paper’s structure is given in Fig. 8 for the convenience of readers. The abbreviations used in this article are listed in Table 3.

II. WIRELESS IoT TECHNIQUES

Wireless connectivity has been widely used in the IoT, as a benefit of its convenient installation and flexible deployment [2]. Wireless networks can be divided into wireless local area networks (WLANs), wireless personal area networks (WPANs) and low power wide area networks (LPWANs). The same taxonomy is used in this paper as well. Naturally, the different wireless techniques have different communication ranges, data rates and energy consumption, since they are designed and optimized for particular applications. For example, WiFi has a high data rate in the order of 100 Mbps, but it is energy-hungry, which is widely used in smartphones and laptops. On the other hand, LoRa can only achieve a rate up to 50 kbps, but can operate for years using a battery, which is suitable for sensor nodes. A summary and comparison of several popular wireless techniques is provided in Table 4 and Fig. 9.

A. WIRELESS LOCAL AREA NETWORKS

IEEE 802.11 is the most popular and successful WLAN technique, which is used in laptops, smartphones, tablets, etc [34]. WiFi is the industrial alliance that adopts and promotes IEEE 802.11 technology. In this paper we use IEEE 802.11 and WiFi interchangeably.

Since its conception in 1997, the WiFi family has evolved quickly with the advances of wireless and semiconductor technologies. It has also had a number of successful

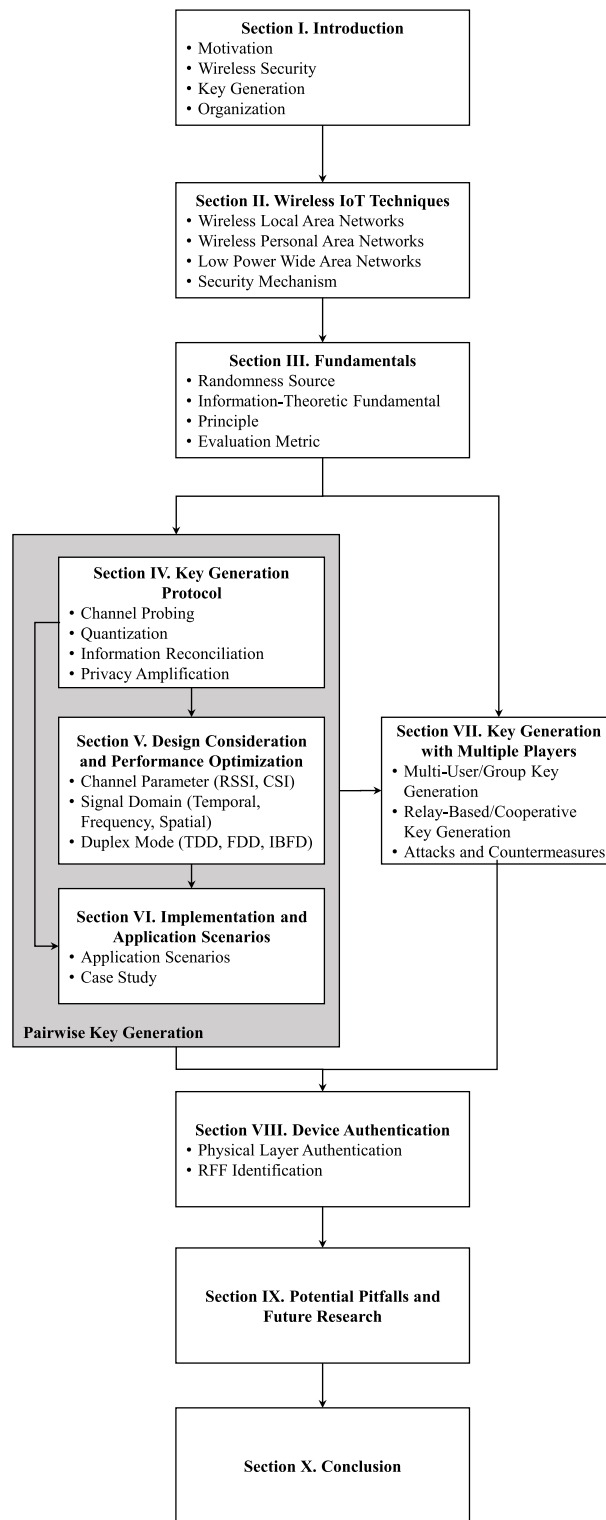

FIGURE 8. Paper structure.

amendments, including *a/b/g/n/ac/ah/ax*, as summarized in Table 5. Orthogonal frequency-division multiplexing (OFDM) is the main physical layer modulation scheme of WiFi, which was first used in IEEE 802.11a in 1999 and later

TABLE 2. Comparison with available surveys and tutorials.

Paper	Ren et al. [81]	Zeng et al. [82]	Wang et al. [83]	Zhang et al. [84]	Zhang et al. [85]	Li et al. [86]	Zhang et al. [87]	This work
Year	2011	2015	2015	2016	2017	2019	2019	2020
Type	Tutorial	Tutorial	Survey	Survey	Tutorial	Survey	Tutorial	Survey
Principle	✓			✓	✓			✓
Protocol	✓	✓	✓	✓	✓		✓	✓
Channel Parameter	✓		✓	✓				✓
Signal Domain			✓					✓
Duplex Mode		✓				✓	✓	✓
Applications				✓	✓	✓	✓	✓
Attack		✓	✓	✓	✓			✓
Relay								✓
Group/Multi-User Key Generation		✓	✓	✓	✓			✓
5G related						✓		✓
Device Authentication							✓	✓

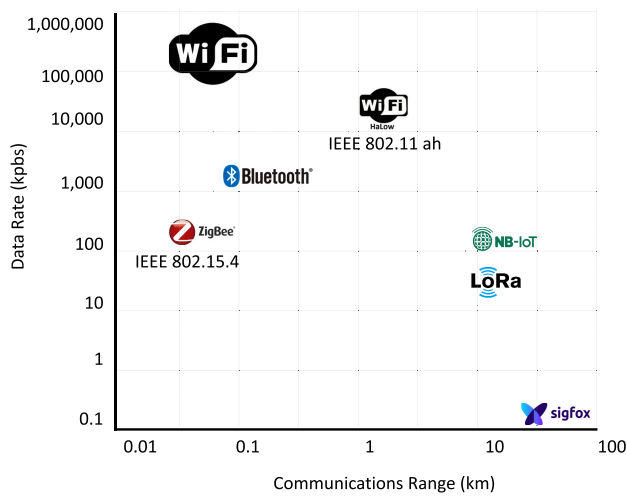

FIGURE 9. Wireless techniques for the IoT.

adopted by IEEE 802.11g/n/ac/ah/ax. OFDM exploits the available spectrum efficiently by transmitting on orthogonal subcarriers/frequencies and improves the communication rate. Following the introduction of IEEE 802.11n (2009), WiFi has been further enhanced by multi-antenna techniques for exploiting spatial diversity. Finally, because of the increased user density, IEEE 802.11ax employs multi-user access techniques for enabling simultaneous transmission between an access point (AP) and multiple stations.

IEEE 802.11 can be used in the smart home and diverse indoor applications, where large amounts of data transfer is required, as in residential camera-based monitoring. However, the communication range remains limited within 100 meters, but the IEEE 802.11ah amendment, also known as WiFi Halow, supports a longer range with coverage of one kilometer radius.

B. WIRELESS PERSONAL AREA NETWORKS

IEEE 802.15.4 defines the physical layer and medium access control (MAC) layer protocols [35] and serves as the basis for ZigBee, 6LoWPAN, WirelessHART, etc. It uses direct-sequence spread spectrum-based transmission of signals. It is particularly suitable for low-power, low-rate (up to 250 kbps) and short-distance (up to 100 meters) communications. It is the main technique used for WPANs and it has been widely used in wireless sensor networks (WSNs) (e.g., for environment monitoring), smart home, industrial automation, etc.

Bluetooth is a low-energy wireless technique for short range communications (50 to 100 m), with a data-rate of up to 1 Mbps. Bluetooth was conceived in 1989 and the latest version is v5.1 (January 2019) [36], which has been widely used in smartphones, laptops and Fitbits. Bluetooth also operates at 2.4 GHz but employs adaptive frequency hopping to avoid channel collision. In contrast to IEEE 802.15.4, Bluetooth uses a single-hop solution, which is suitable for healthcare devices and consumer electronics [88].

Ultra-wideband (UWB) is a low-energy technique conceived for short-range, high-bandwidth (> 500 MHz) communications [89]. It has been included in the IEEE 802.15.4-2015 standard for WPANs and IEEE 802.15.6-2012 standard for wireless body area networks (WBAN). Numerous solutions have been proposed for UWB systems, relying on impulse radio [89], OFDM [90] and multi-stage frequency hopping [91], just to name a few.

C. LOW POWER WIDE AREA NETWORKS

Many IoT applications rely on distributed devices in a wide area, thus will have to use long range communications, for example, for environmental monitoring and smart cities. These IoT devices should also be low power to support long operation. The wireless connection techniques are thus termed as *low power wide area networks*

TABLE 3. Abbreviation.

Abbreviation	Definition
ACF	Autocorrelation function
AES	Advanced encryption standard
CDF	Cumulative distribution function
CFR	Channel frequency response
CIR	Channel impulse response
COTS	Commercial off-the-shelf
CRC	Cyclic redundancy check
CSI	channel state information
DDoS	Distributed denial of service
DES	Data encryption standard
ECDH	Elliptic curves Diffie-Hellman
FDD	Frequency division duplex
FEC	Forward error correction
IBFD	In-band full-duplex
IoT	Internet of Things
KDR	Key disagreement rate
KGR	Key generation rate
LDPC	Low Density Parity Check
LOS	Line-of-sight
LPWAN	Low power wide area network
MIMO	Multiple-input and multiple-output
MITM	Man-in-the-middle
NB-IoT	Narrowband IoT
NIC	Network interface card
NIST	National Institute of Standards and Technology
OFDM	Orthogonal frequency-division multiplexing
PCA	Principal component analysis
PKC	Public key cryptography
PKI	Public key infrastructure
RFF	Radio frequency fingerprinting
RMS	Root mean squared
RNG	Random number generator
RSSI	Received signal strength indicator
SDR	Software defined radio
SIFS	Short interframe space
SKR	Secret key rate
TDD	Time division duplex
USRP	Universal Software Radio Peripheral
UAV	Unmanned aerial vehicles
UWB	Ultra-wideband
WBAN	Wireless body area networks
WLAN	Wireless local area networks
WPA	WiFi protected access
WPAN	Wireless personal area networks
WSN	Wireless sensor networks
WSSUS	Wide sense stationary uncorrelated scattering

(LPWAN) [92]. LPWAN techniques have become prevalent, including LoRa/LoRaWAN, Sigfox, and NB-IoT. Both LoRa/LoRaWAN and Sigfox operate in the unlicensed ISM bands, while NB-IoT is a cellular technique [38].

LoRa is a physical layer modulation technique patented by Semtech, which employs chirp spread spectrum transmission for distances as high as 15 km. LoRaWAN is proposed by the LoRa Alliance [37], which defines the MAC layer protocol and network architecture. The LoRaWAN scheme operates at sub-GHz carriers but the specific frequency plans of different countries vary [93]. SigFox uses an ultra-narrow band technique for supporting extremely long-range transmissions, namely up to 30 to 50 km in rural areas or 3 to 10 km in urban environments. Again, NB-IoT is a cellular technique operating in a licensed band. It works in the classic frequency division duplex (FDD) mode, which poses challenges for the key generation process, because the uplink and downlink channels are not necessarily similar at different frequencies.

D. SECURITY MECHANISM

IoT security has attracted extensive research interests in diverse fields, such as Internet of Vehicles [94], [95], smart homes [96], healthcare [97]–[99], etc. As summarized in Table 4, AES-based encryption is widely used for achieving data confidentiality and integrity in the IoT. AES can be implemented in a hardware-friendly manner, which is very suitable for low-cost IoT devices. For example, AES has been integrated into the popular Texas Instruments (TI) ZigBee chipset, cc253x [100].

While the IoT standards have defined the encryption mechanisms, a secure and efficient key distribution scheme is still currently missing. Key generation is an ideal candidate technique for establishing cryptographic keys for legitimate users in a lightweight and secure manner.

III. FUNDAMENTALS

This section will cover the randomness source, key generation principles, information-theoretical fundamentals and metrics. These aspects will be linked to each other.

A. RANDOMNESS SOURCE

Wireless communications undergo large-scale fading, including the path loss and shadow fading, as well as small scale multipath fading [101]. The path loss represents the power decay over the transmission path, which is a direct function of the transmission distance, whilst its steepness depends both on the carrier frequency and on the building patterns for example. However, the path loss is rather deterministic and thus is not secure for key generation [102]. On the other hand, shadow fading is a correlated random process caused by large obstacles in the environment, such as buildings, which has been used for key generation in [102]. However, shadow fading is changing relatively slowly, which limits the key generation performance. Experimental validation of key

TABLE 4. Wireless techniques for the IoT.

Wireless Technique	Frequency	Range	Data Rate	Security Mechanism
IEEE 802.15.4	2.4 GHz	10 to 100 m	250 kps	AES in MAC layer
Bluetooth Low Power	2.4 GHz	50 to 150 m	1 Mbps	AES in link layer
IEEE 802.11 a/b/g/n/ac/ax	2.4 or 5 GHz	50 m	> 100 Mbps	WPA in MAC layer (with AES implemented)
IEEE 802.11 ah	sub GHz	1 km	150 kbps	WPA in MAC layer (with AES implemented)
LoRa/LoRaWAN	sub GHz	15 km	0.3 kbps to 50 kbps	AES 128 Encryption at network and application layer
SigFox	sub GHz	30-50 km in rural areas or 3-10 km in urban area	200 bps	AES-based cryptography
NB-IoT	sub GHz, licensed band	18 - 21 km	200 kbps	Symmetric key cryptography, e.g., UEA2 and UIA2, AKA, etc.

generation based on shadow fading is not available at the time of writing.

Hence, the majority of key generation contributions focus on the small-scale fading. As shown in Fig. 10, the electromagnetic wave undergoes reflections, refraction and scattering in the environment. These effects are unpredictable and can be used as the random source of key generation.

TABLE 5. IEEE 802.11 Physical layer evolution.

Amendment	Release Year	Frequency (GHz)	Modulation
IEEE 802.11	1997	2.4	DSSS, FHSS
IEEE 802.11b	1999	2.4	DSSS
IEEE 802.11a	1999	5	OFDM
IEEE 802.11g	2003	2.4	OFDM
IEEE 802.11n	2009	2.4/5	MIMO OFDM
IEEE 802.11ac	2013	5	MIMO OFDM
IEEE 802.11ah	2016	sub GHz	MIMO OFDM
IEEE 802.11ax	Est. 2020	2.4/5	MIMO OFDM, multi user

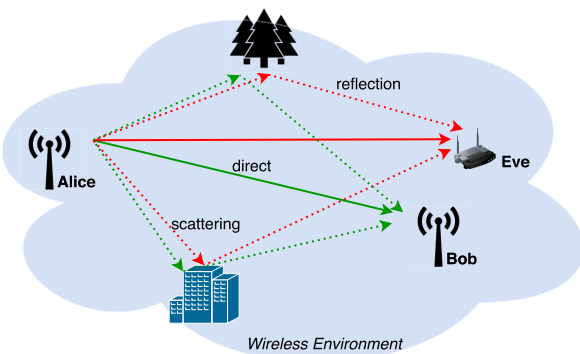

FIGURE 10. Multipath effects of wireless channels.

Channel modelling is essential for designing reliable and efficient key generation. A detailed channel model² for both

²From now on, channel model represents the modelling of wireless channels, but is not related to the channel model of secret key agreement.

narrowband and wideband channels can be found in Chapter 3 of [101]. This section will provide a brief introduction to the relevant channel effects. The multipath channel can be modelled by several resolvable path components. The corresponding channel impulse response (CIR), $h^{uv}(\tau, t)$, between the transmitter u and receiver v can be mathematically expressed as

$$h^{uv}(\tau, t) = \sum_{l=1}^{L^{uv}(t)} \alpha_l^{uv}(t) e^{-j\phi_l^{uv}(t)} \delta(\tau - \tau_l^{uv}(t)), \quad (2)$$

where $\alpha_l^{uv}(t)$, $\phi_l^{uv}(t)$ and $\tau_l^{uv}(t)$ are the amplitude attenuation, phase shift and time delay of the l^{th} tap, respectively, $L^{uv}(t)$ is the total number of paths and $\delta(\cdot)$ is the Dirac function.

When a signal $s(t)$ is transmitted via a multipath channel, the received signal is given by the convolution of

$$y(t) = \int_0^{\tau_{\max}} h^{uv}(\tau, t) s(t - \tau) d\tau + n^v(t), \quad (3)$$

where $n^v(t)$ is the noise at receiver v and τ_{\max} is the maximum channel delay. The received power of a packet having a duration of T_{pkt} is given as

$$P(t) = \frac{1}{T_{pkt}} \int_t^{t+T_{pkt}} |y(t')|^2 dt'. \quad (4)$$

The received signal can be converted to the frequency domain, which is given by

$$Y(f, t) = H^{uv}(f, t) S(f, t) + w^v(f, t), \quad (5)$$

where $H^{uv}(f, t)$ is the corresponding channel frequency response (CFR) given by

$$H^{uv}(f, t) = \int_0^{\tau_{\max}} h^{uv}(\tau, t) e^{-j2\pi f\tau} d\tau. \quad (6)$$

The CIR $h^{uv}(\tau, t)$ includes the intrinsic randomness source, which can be represented by the CFR $H^{uv}(f, t)$ and received power $P(t)$ as well. A detailed introduction to these parameters will be given in Section V-A. We use X^u to denote the channel observation of user u , which can be one of the above parameters. The channel effects are determined by the specific environment (indoor or outdoor), the reflector and scatterer material and distribution, which leads to unpredictable

fading of the wireless channels. Depending on the wireless technique adopted, key generation exploits these features by measuring X^u and extracts the common randomness as the key.

B. INFORMATION-THEORETIC FUNDAMENTAL

The source model of key generation is given in Fig. 11, which involves two legitimate users, Alice and Bob, and a passive eavesdropper, Eve [47]. Alice, Bob and Eve acquire the channel observations $X^A = [x^A(1), x^A(2), \dots, x^A(n)]$, $X^B = [x^B(1), x^B(2), \dots, x^B(n)]$, and $X^E = [x^E(1), x^E(2), \dots, x^E(n)]$, respectively.

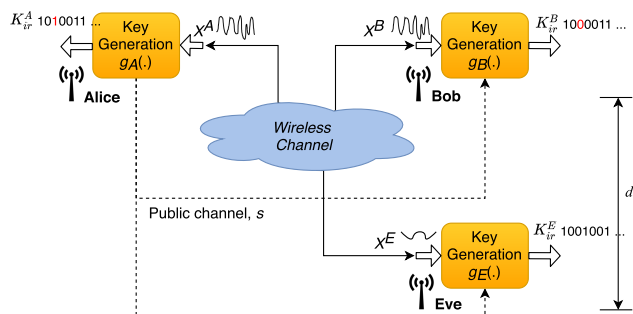

FIGURE 11. Key generation source model.

Key generation is information-theoretically secure, which has been shown in the pair of seminal papers [51], [52]. In order to agree on using the same key, Alice and Bob will have to exchange some information s over the public channel, which can be overheard by Eve as well. For any ϵ and sufficiently large n , there exists a key generation protocol, $K_{ir}^A = g_A(X^A)$ and $K_{ir}^B = g_B(X^B, s)$, which satisfies

$$\Pr(K_{ir}^A \neq K_{ir}^B) < \epsilon, \tag{7}$$

$$\frac{1}{n} I(K_{ir}^A; s, X^E) < \epsilon, \tag{8}$$

$$\frac{1}{n} \mathbb{H}(K_{ir}^A) > R - \epsilon, \tag{9}$$

$$\frac{1}{n} \log |\mathcal{K}| < \frac{1}{n} \mathbb{H}(K_{ir}^A) + \epsilon, \tag{10}$$

where $I(\cdot)$ denotes mutual information and \mathcal{K} represents the key's alphabet. (7) is about the channel reciprocity, which indicates that Alice and Bob can get the same keys with a high probability. Furthermore, (8) is based on the spatial decorrelation, which means that Eve cannot infer the keys based on her observation and the public discussion s . Finally, (10) describes the temporal variation, which ensures having a uniformly distributed key.

A detailed introduction of the information-theoretical model of key generation can be found in Chapter 4 of [47].

C. PRINCIPLE

The above information-theoretical modelling can be described by three key generation principles.

1) CHANNEL RECIPROCITY

Channel reciprocity indicates that the channel gains and phases are the same at both ends of the link. As seen in (7), Alice and Bob can then generate the same keys, K_{ir}^A and K_{ir}^B , from their channel observations, namely X^A and X^B , respectively. However, the channel reciprocity is impacted in practice by the specific duplex mode used, the hardware imbalance, interference and noise, which will be further discussed in Section IV-A1 and Section V-C.

2) SPATIAL DECORRELATION

According to Jakes' Doppler model [103], the correlation function is represented by the Bessel function of zeroth order and first kind in a rich multipath environment with infinite and uniformly distributed scatterers. Thus the eavesdroppers will experience uncorrelated fading, when they are located at least 0.4λ (approximately half wavelength) away from the legitimate users [101]. This feature is termed as spatial decorrelation, which is essential to the security of key generation. As seen in (8), based on the uncorrelated channel observation and the public messages received, Eve is unable to extract the key. However, the condition is quite rigid, which may not hold in a real environment. More detailed discussions will be presented in Section VII-C1.

3) TEMPORAL VARIATION

Temporal variation describes the channel variation over time, which can be caused by the movement of the transmitter, receiver and any objects within the environment. Having temporal variations is essential for generating random uniformly distributed keys, as seen in (10), which are desired by cryptographic applications. A detailed study will be given in Section V-B1.

D. EVALUATION METRIC

There are a number of metrics in the key generation area for evaluating the quality of the keys generated.

1) CROSS-CORRELATION

The signal similarity can be quantified by the cross-correlation coefficient between the measurements of user u and user v , i.e. X^u and X^v , which is formulated as

$$\rho^{uv} = \frac{E\{X^u X^v\} - E\{X^u\}E\{X^v\}}{\sigma^u \sigma^v}, \tag{11}$$

where $E\{\cdot\}$ denotes the expectation operation and σ_u is the standard deviation of X^u .

2) KEY DISAGREEMENT RATE (KDR)

The KDR quantifies the difference between the raw keys generated at user u and user v after the quantization, i.e., K_q^u and K_q^v , which is mathematically expressed as

$$KDR^{uv} = \frac{\sum_{i=1}^{n_k} |K_q^u(i) - K_q^v(i)|}{n_k}, \tag{12}$$

where n_k is the length of keys. A KDR modelling technique was formulated for OFDM systems and was also validated by measurements in [104].

3) SECRET KEY RATE (SKR)

SKR is the upper bound on the number of bits per channel observation that Alice and Bob can generate, about which Eve cannot obtain any useful information based on her own observation. Maurer proved the following lower bound and upper bound on the key rate in [52], which are given as

$$R(X^A, X^B \| X^E) \geq \max\{I(X^A; X^B) - I(X^A; X^E), I(X^A; X^B) - I(X^B; X^E)\}, \quad (13)$$

and

$$R(X^A, X^B \| X^E) \leq \min\{I(X^A; X^B), I(X^A; X^B | X^E)\}, \quad (14)$$

respectively. The maximum attainable SKR of a Nakagami m fading channel was quantified in [105].

4) KEY GENERATION RATE (KGR)

KGR describes the number of key bits generated in each unit time interval, e.g., bit per second or bit per measurement. Note that KGR represents the actual rate of the key produced by a key generation system, while the SKR indicates the theoretical maximum rate that the system can achieve. Alice and Bob can get a KGR approaching the SKR with the aid of well-designed protocols.

5) AUTOCORRELATION FUNCTION

The signal variation can be quantified by the autocorrelation function (ACF) of the signal, which is given by

$$r^u(t, \Delta t) = \frac{E\{(X^u(t) - \mu^u)(X^u(t + \Delta t) - \mu^u)\}}{\sigma_u^2}, \quad (15)$$

where μ^u represents the mean value of the random variable X^u . The ACF of the channel responses is theoretically modelled in [60], for a wide sense stationary uncorrelated scattering (WSSUS) channel.

6) RANDOMNESS

Because the keys generated are used for cryptographic applications, they are exposed to the risk of brute-force attack, unless the key is truly random. The National Institute of Standards and Technology (NIST) random test suite is widely used to evaluate the randomness for random number generators (RNG) and pseudo random number generators (PRNG) [106]. Key generation is a RNG therefore this test suite can also be used for this purpose.

The suite includes a total of 15 tests, each evaluating a specific feature, as shown in Table 6. Each test returns a P -value, which is compared to a statistical significance level α , typically in the range of [0.001 0.01]. When the P -value $> \alpha$, the sequence passes the test. Some tests require a long sequence with e.g., 10^6 bits, which cannot be readily gleaned from key generation simulations and experiments. Therefore,

only a subset of tests are used for evaluating whether the keys generated possess these features.

TABLE 6. NIST random test suite [106].

Test	Purpose	Recommended key size n_k
Frequency (monobit) test	Proportion of zeros and ones for the entire sequence	100
Frequency test within a block	To determine whether the frequency of ones in an M -bit block is approximately $M/2$	100
Runs test	Total number of runs in the sequence, where a run is an uninterrupted sequence of identical bits	100
Longest run of ones in a block test	Longest run of ones within M -bit blocks	$n_k=128, M=8$
Binary matrix rank test	Check linear dependence among fixed length substrings of the original sequence	38,912
Discrete fourier transform (Spectral) test	To detect periodic features(i.e., repetitive patterns that are near each other)	1000
Non-overlapping template matching test	To detect generators that produce too many occurrences of a given non-periodic (aperiodic) pattern	Not specified
Overlapping template matching test	To detect generators that produce too many occurrences of a given non-periodic (aperiodic) pattern	10^6
Maurer's universal statistical test	To detect whether or not the sequence can be significantly compressed without loss of information	387,840
Linear complexity test	To determine whether or not the sequence is complex enough to be considered random	10^6
Serial test	The frequency of all possible overlapping m -bit patterns across the entire sequence	Choose m and n such that $m < \lfloor (\log_2 n_k - 2) \rfloor$
Approximate entropy test	To compare the frequency of overlapping blocks of two consecutive/adjacent lengths(m and $m+1$) against the expected result for a random sequence	Choose m and n such that $m < \lfloor (\log_2 n_k - 5) \rfloor$
Cumulative Sums test	The maximal excursion (from zero) of the random walk defined by the cumulative sum of adjusted (-1, +1) digits in the sequence	100
Random excursions test	The number of cycles having exactly K visits in a cumulative sum random walk	10^6
Random excursions variant test	To detect deviations from the expected number of visits to various states in the random walk	10^6

An official C implementation is provided for download at [107] and a Python implementation is also available at github [108].

E. SUMMARY

The key generation principles, information-theoretic fundamentals and the evaluation metrics are intricately linked to each other, which is summarized in Table 7. The metrics evaluate both the quality of analog measurements (cross-correlation and ACF, SKR) and the performance metrics such as the KDR, KGR and randomness.

TABLE 7. Relationships among principle, information-theoretic fundamental and metric.

Principle	Information-Theoretic Fundamental	Metric
Channel reciprocity	$\Pr(K_{ir}^A \neq K_{ir}^B) < \epsilon$	Cross CorrCoeff, KDR
Spatial decorrelation	$\frac{1}{n} I(K_{ir}^A; s, Z^n) < \epsilon$	Cross CorrCoeff, KDR
Temporal variation	$\frac{1}{n} H(K_{ir}^A) > R - \epsilon$	Randomness, ACF, KGR, SKR

IV. KEY GENERATION PROTOCOL

A key generation protocol typically relies on four stages, including channel probing, quantization, information reconciliation and privacy amplification, which are portrayed in Fig. 12 and will be detailed later in this Section. Alice and Bob first carry out channel probing, which involves bidirectional measurements, and will obtain the measurements X^A and X^B , respectively. They then convert the analog measurements into digital binaries, namely K_q^A and K_q^B . There will probably be mismatch between K_q^A and K_q^B , hence information reconciliation has to be adopted to correct the mismatch; Alice and Bob will then obtain K_{ir}^A and K_{ir}^B , respectively. Finally, privacy amplification is employed and the legitimate users acquire K^A and K^B . Again, this section will introduce each of these stages in detail.

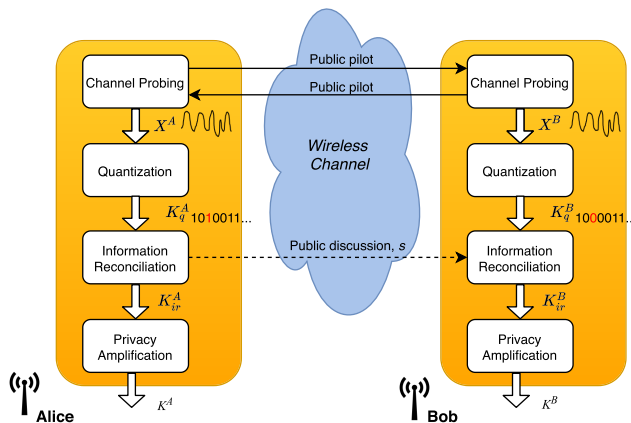

FIGURE 12. Key generation protocol.

A. CHANNEL PROBING

Channel probing is the most essential step of key generation from wireless channels. The users will sample the channel via packet transmissions, which may be subject to all typical channel effects, such as sampling delay, interference and noise. Signal preprocessing can thus be adopted for improving the measurement quality.

1) CHANNEL SAMPLING

Key generation requires bi-directional measurements, so that both users can glean the reciprocal channel information. Here, we describe the channel sampling process of time division duplex (TDD) systems as an example, while channel

sampling associated with other duplex modes will be discussed in Section V-C.

The timing of the TDD-based channel sampling is illustrated in Fig. 13. At the i^{th} sampling instant $t_a(i)$, Alice sends a request packet to Bob, who will obtain the measurement $X^B(i)$. After a time delay Δt , Bob replies with a packet to Alice, who will also measure the same parameter and get $X^A(i)$. Because in TDD schemes both directions use the same carrier frequency, unless strong frequency-selective fading and different co-channel interference are encountered, the complex-valued channel envelope remains near-constant during the coherence time T_c (defined in (23)). Hence, Alice and Bob can get highly correlated measurements. Alice and Bob will repeat the above sampling every T_s time interval, where $T_s > T_c$, in order to avoid having correlated samples. Figs. 14(a) and 14(b) show the received power sampled by using WiFi in an indoor environment and using LoRa in an urban environment, respectively.

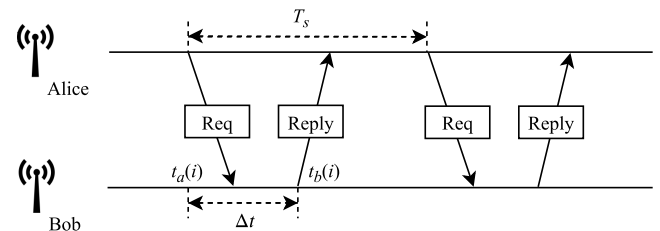

FIGURE 13. Channel probing/sampling in TDD systems. Request and reply packets serve as the two-way measurements.

It is worth noting that at this early stage of their communications, Alice and Bob do not intend to decrypt the received messages, they simply aim to measure the channel using these sampling pilots and public links. Additionally, the legitimate users may also rely on payload data packets to sample the channel, if extra packet transmissions have to be avoided [68]. For example, each DATA packet will be confirmed by an Acknowledgement packet in classic WiFi transmissions, which jointly constitute a perfect pair for key generation. Therefore key generation does not impose additional energy consumption, which is beneficial for IoT devices.

2) SIGNAL PREPROCESSING

Signal preprocessing mainly deals with two problems of the raw channel measurements, i.e., the channel reciprocity impairment and sample autocorrelation.

Channel reciprocity impairments are caused by hardware imbalance, fading, interference imbalance and noise.

- Different duplex modes have different impacts, e.g., sampling delay in TDD systems, independent fading caused by frequency separation of the uplink and downlink carriers in FDD systems and self interference in in-band full-duplex (IBFD) systems.

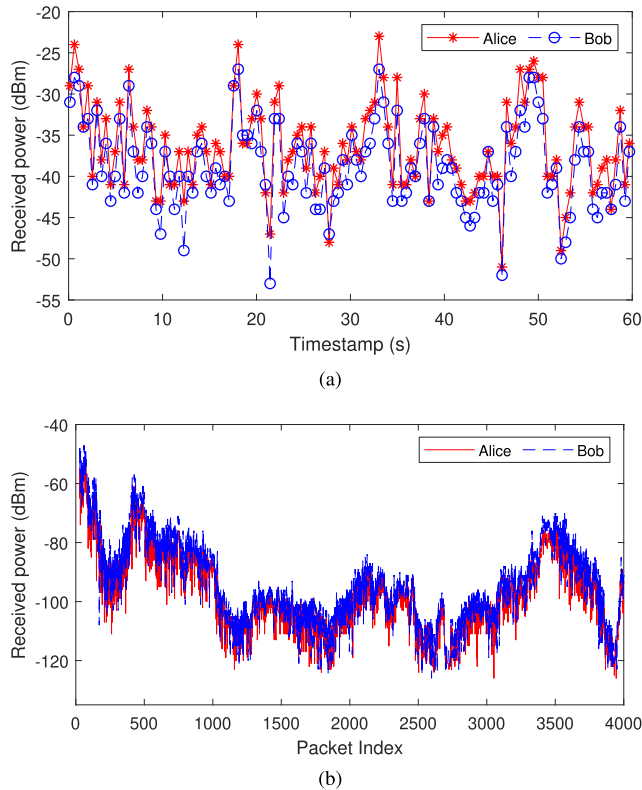

FIGURE 14. (a) Channel sampling using Wi-Fi in an indoor office environment. (b) Channel sampling using LoRa in an urban environment.

- Hardware imbalance implies that the transmit and receive radio frequency chains in transceivers are not identical.
- Both inter-symbol and multi-user interference may be inflicted by the network. Fading is caused by mobility, while thermal noise is owing to the Brownian motion of electrons in the receiver.

As observed from the results in Figs. 14(a) and 14(b), the received powers of Alice and Bob are highly correlated, but not exactly the same in both scenarios. The received power variation is as high as 70 dBm in the LoRa-based large scale experiments, compared to the more moderate 25 dBm variation in the WiFi-based indoor environment.

The undesired autocorrelation manifests itself between the adjacent measurements, when the two probes are within the same coherence time and/or coherence bandwidth, which will introduce redundancy. This correlation may be introduced in the temporal, frequency and spatial domains, when employing for example OFDM techniques [60], [73], [109] or multiple antennas [58], [72], [110].

Various signal preprocessing algorithms have been proposed to address the above issues, which are summarized as follows.

- The countermeasures of mitigating the correlation of duplex modes will be given in Section V-C.
- Hardware asymmetry can be mitigated by calibration in advance [111]. As another innovative technique,

a real-time transform based on the time-invariant nature of hardware imbalance was proposed for time-varying TDD channels without involving any calibration [112].

- Interference, noise and autocorrelation reduction are usually addressed by transform domain algorithms, relying on principal component analysis (PCA) [62], [65], [110], discrete cosine transform (DCT) [113], [114] and wavelet transform (WT) [115], [116]. These preprocessing schemes are summarized and compared in [117]. Raw channel measurements may be readily mapped into transform domains and typically only the low-frequency components are used for key establishment to reduce KDR. Li *et al.* constructed a general mathematical model for various linear signal processing transforms and proved that PCA achieves the optimal SKR [65].

B. QUANTIZATION

Following the above channel probing process, Alice and Bob obtain a series of analog channel measurements, X^A and X^B , respectively, but binary keys are required for cryptographic schemes. The quantization stage converts the analog channel measurements into digital binary sequences, K_q^A and K_q^B . We refer to the quantized binary sequence as the preliminary key material. Quantization can be categorized into absolute value-based and difference value-based quantization, which will be introduced.

1) ABSOLUTE VALUE-BASED QUANTIZATION

An absolute value-based quantizer converts the analog values into binary representations by comparing the measurements to thresholds. The key design parameters include the threshold value selection and the number of quantization levels.

Mean and standard deviation-based quantization is the most popular one, which is summarized by the pseudo code given in Algorithm 1. An example is shown in Fig. 15, in conjunction with $\alpha = 0$, which corresponds to mean value-based quantization. The quantizer is simple to implement, since it only requires the mean and variance of the samples for calculating the threshold. However, it is not robust to burst errors, which are quite common in wireless communications. Explicitly, the burst errors may significantly affect the threshold and result in unbalance between the proportions of 1s and 0s.

Cumulative distribution function (CDF)-based quantization operates differently from the above quantizer in terms of its threshold selection procedure [62], as detailed in Algorithm 2. The threshold is calculated based on the distribution of measurements, and as a benefit an even proportion between 1s and 0s can be ensured. It can also be designed for multi-bit quantization by assigning more quantization levels and thresholds [62], [73]. Usually, a Gray code is adopted for ensuring that similar samples result in similar binary strings having only a single different bit position, hence yielding a Hamming distance of one. However, CDF-based quantizers are more complex, requiring more resources.

Algorithm 1 Mean and Standard Deviation-Based Quantization

INPUT: X^u % Channel measurement
INPUT: α % Tuning parameter
OUTPUT: K_q^u % Generated key sequence of user u

- 1: $\eta_+^u = \mu_{X^u} + \alpha \times \sigma_{X^u}$ % η_+^u is the positive threshold.
- 2: $\eta_-^u = \mu_{X^u} - \alpha \times \sigma_{X^u}$ % η_-^u is the negative threshold.
- 3: **for** $i \leftarrow 1$ **to** N_p **do**
- 4: **if** $X^u(i) > \eta_+^u$ **then**
- 5: $K_q^u(i) = 1$
- 6: **else if** $X^u(i) < \eta_-^u$ **then**
- 7: $K_q^u(i) = 0$
- 8: **else**
- 9: $X^u(i)$ dropped
- 10: **end if**
- 11: **end for**

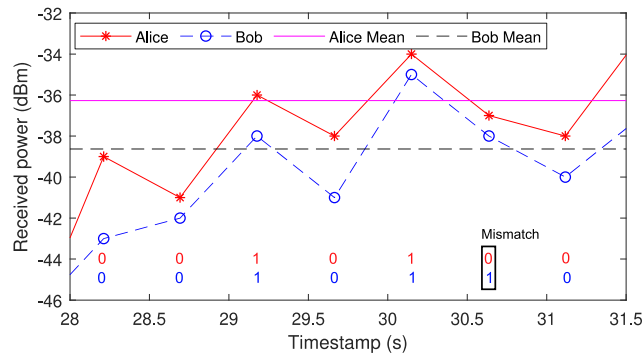

FIGURE 15. Mean value-based quantization with received power sampled by using WiFi in an indoor office environment. The mean values are calculated based on all the received power in Fig. 14(a).

Algorithm 2 CDF-Based Quantization

INPUT: X^u % Channel measurement
INPUT: QL % Quantization level
OUTPUT: K_q^u % Generated key sequence of user u

- 1: $F(x) = \Pr(X^u < x)$ % CDF calculation
- 2: $\eta_0^u = -\infty$ % Threshold
- 3: **for** $j \leftarrow 1$ **to** $2^{QL} - 1$ **do**
- 4: $\eta_j^u = F^{-1}(\frac{j}{2^{QL}})$ % Threshold
- 5: **end for**
- 6: $\eta_{2^{QL}}^u = \infty$
- 7: Construct Gray code b_j and assign them to different intervals $[\eta_{j-1}^u, \eta_j^u]$
- 8: **for** $i \leftarrow 1$ **to** N_p **do**
- 9: **if** $\eta_{j-1}^u \leq X^u(i) < \eta_j^u$ **then**
- 10: $K_q^u(i, QL) = b_j$
- 11: **end if**
- 12: **end for**

2) DIFFERENTIAL VALUE-BASED QUANTIZATION

In contrast to absolute value-based quantizers, a differential value-based quantizer generates keys by comparing a pair of

Algorithm 3 Differential-Based Quantization

INPUT: X^u % Channel measurement
INPUT: ϵ % Parameter resolution
OUTPUT: K_q^u % Generated key sequence of user u

- 1: **for** $i \leftarrow 1$ **to** $N_p - 1$ **do**
- 2: **if** $X^u(i+1) > X^u(i) + \epsilon$ **then**
- 3: $K_q^u(i) = 1$
- 4: **else if** $X^u(i+1) < X^u(i) - \epsilon$ **then**
- 5: $K_q^u(i) = 0$
- 6: **else**
- 7: $X^u(i)$ dropped
- 8: **end if**
- 9: **end for**

the adjacent measurements [118], as seen in Algorithm 3. The difference threshold of ϵ is introduced to ensure that minor fluctuations caused by hardware noise are ignored. An example is given in Fig. 16 in conjunction with $\epsilon = 0$.

This quantizer is eminently suitable for large-scale outdoor environments, where the channel variation is high but changing slowly. A case study can be found in [77], where LoRa-based key generation experiments were carried out in an urban environment. As shown in Fig. 16, the mean value-based quantizer may result in large chunks of 1s (or 0s), because the signal variation is not high enough compared to the global mean value. This can be improved by block-wise quantization, i.e. by partitioning the measurements into small blocks and quantizing individual blocks [70]. However, the block-based quantizer has to learn the environment in order to determine and adjust the length of the blocks.

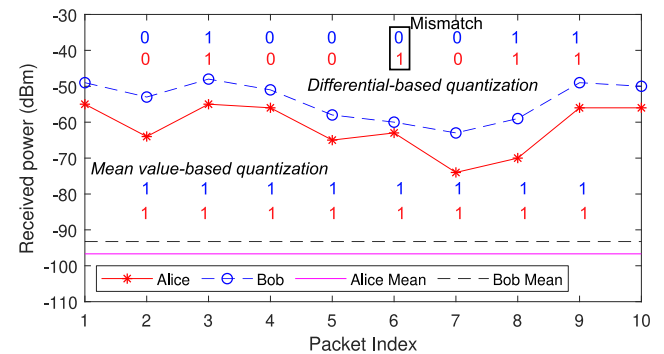

FIGURE 16. Differential-based quantization with received power sampled by using LoRa in an urban environment. The mean value-based quantizer does not work in this case. The mean values are calculated based on all the received power in Fig. 14(b).

3) SUMMARY

Quantization determines the KGR, as it directly controls the number of key bits that can be generated per measurement. To this end, a number of quantizer variants of the above two main approaches have been designed and tested. A comparison among different quantizers can be found in [119], [120].

Different from the above quantizers, the work in [121] employed the machine learning clustering algorithms, namely the k-means, for quantization. The authors used the real and imaginary parts of the channel coefficients as the clustering features, calculated a number of cluster centers, and assigned gray codes to these centers.

C. INFORMATION RECONCILIATION

The objective of key generation is to generate a pair of identical symmetric keys at Alice and Bob for cryptographic applications. Even a single bit difference would result in decryption failure, due to the avalanche-like effects. As shown in Fig. 15 and Fig. 16, even when the absolute values of the received power of Alice and Bob are very close, Alice and Bob may still quantize them differently.

To address this issue, information reconciliation has to be used for detecting and correcting the errors in the preliminary key material between a pair of legitimate parties, i.e., K_q^A and K_q^B . A survey of the information reconciliation techniques can be found in [122]. Information reconciliation tends to rely on a pair of approaches, i.e., error detection protocol based approaches (EDPA) and error correction code based approaches (ECCA).

It is worth mentioning that many of the information reconciliation and privacy amplification methods used in wireless key generation are borrowed from the field of quantum key distribution (QKD) [123].

1) EDPA

As described in Fig. 17, Alice first partitions the preliminary key material gleaned from the signals received from Bob into small blocks and sends parity information of each block to Bob. Similarly, Bob also partitions his key material in the same way, derives parity check bits and checks for mismatches between his own parity bits and those received from Alice. For each mismatch, Bob performs a binary search right across the block to find a correction vector, which may fix the errors. These steps may be repeated a number of times to eliminate mismatches and to obtain a high probability of success.

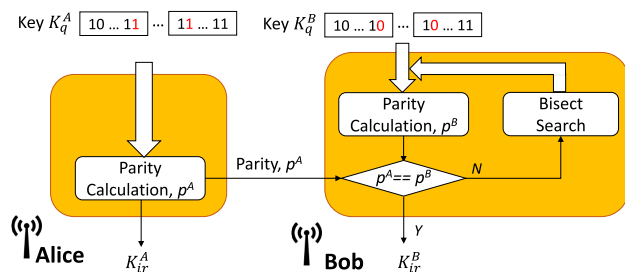

FIGURE 17. Information reconciliation, EDPA.

Specific examples of EDPA schemes include BBBSS [124], Cascade [125] and Winnow [126]. To elaborate a little further, Bennett et al. proposed the permute-and-bisect method for the

first implementation of QKD in [124]. As a further advance conceived for reducing the information leakage, Brassard and Salvail proposed an improved scheme termed as Cascade in [125], which exploits the information gleaned from the preceding iterations for correcting errors during the current pass. A more efficient implementation of Cascade exploits some inherent information already available in the protocol, such as exactly known bits and/or already known parities [127]. In contrast to BBBSS and Cascade, Buttler et al. [126] proposed to correct the errors in the block using syndrome-based error correction in the context of Hamming codes. The parity bits and syndromes can be calculated and exchanged in parallel. However, Winnow may introduce new errors if the error count per block is more than two. A modified one-way error reconciliation protocol using a Hamming code-based concatenated scheme was proposed to study the relationship between the error correction capability and the key generation efficiency in [128].

2) ECCA

Information reconciliation may also be viewed as a special case of channel coding and correction. Therefore, literally the entire family of forward error correction (FEC) codes can be adapted for reconciliation. Hence numerous error correction codes have been used for information reconciliation, including BCH codes [129]–[131], Reed-Solomon codes [132], Golay codes [133]–[135], turbo [136], polar [137] and low density parity check (LDPC) codes [16], [59], [71], [138].

The ECCA algorithm is described in Fig. 18. Again, Alice and Bob first partition the preliminary key material into blocks. Then, by relying on an error correction code, Alice encodes the key materials, K_q^A , calculates and sends the syndrome to Bob. Bob applies the corresponding decoder, whereby the required codeword is composed of Bob’s key, K_q^B and the received syndrome. When the number of bit disagreements is smaller than the code’s error correcting capability, having synchronized key material is guaranteed by this single-round interaction. Following the error correction procedure, the key agreement can be confirmed by employing CRC. If the check values of Alice and Bob match, i.e., $p^A = p^B$, Alice and Bob generate the same keys and they will proceed to the privacy amplification stage. Otherwise, they will have to start over from the channel probing stage.

To elaborate a little further, secure sketch is a widely used ECCA information reconciliation protocol [129], which is described in Algorithm 4 and illustrated in Fig. 19. We use BCH coding as an example. A BCH (n, k, t) code has an n -bit codeword and k -bit message; it can correct up to t -bit errors. As shown in Fig. 19, Alice first randomly selects a codeword c from the BCH code set C . Alice then calculates the syndrome based on the exclusive-OR operation, given as $s = \text{XOR}(K_q^A, c)$. It should be noted that the syndrome calculation here is different from that of classic FEC. After that, she transmits the syndrome s to Bob. Assuming Bob receives the syndrome correctly, he calculates a codeword

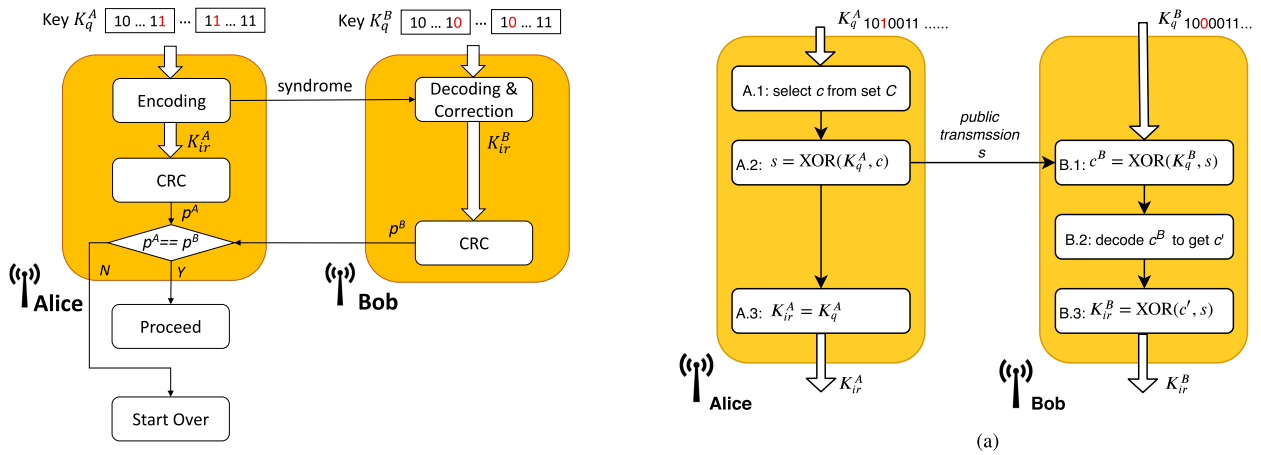

FIGURE 18. Information reconciliation, ECCA.

Algorithm 4 Information Reconciliation, Secure Sketch

INPUT: K_q^A, K_q^B % Quantized keys of Alice and Bob
INPUT: C % ECC set shared by Alice and Bob
OUTPUT: K_{ir}^A, K_{ir}^B % Reconciled key

- 1: A.1: Alice randomly selects a code c from an ECC set C
- 2: A.2: Alice calculates the syndrome $s = \text{XOR}(K_q^A, c)$ and transmits s to Bob through a public channel
- 3: A.3: Alice assigns $K_{ir}^A = K_q^A$
- 4: B.1: Bob receives s and calculates $c^B = \text{XOR}(K_q^B, s)$
- 5: B.2: Bob decodes c^B to get c'
- 6: B.3: Bob calculates $K_{ir}^B = \text{XOR}(c', s)$

as $c^B = \text{XOR}(K_q^B, s)$. When the errors are correctable, Bob can get c' by decoding c^B , and arrives at $c' = c$. Finally, he will get a new key by exclusive-OR operation, namely $K_{ir}^B = \text{XOR}(c', s)$. Fig. 19(b) exemplifies the error correction process by using the BCH (7,4,1) code as an example, which has a codeword length of $n = 7$ and can correct $t = 1$ bit error. Let us consider $K_q^A = [1010011]$ and $K_q^B = [1000011]$ as an example, where there is a single bit difference between them. This will result in one bit difference between c^B and c , which is within the code's correction capacity.

There are also other FEC-based information reconciliation techniques. Treeviriyapap *et al.* used the syndromes of a BCH code for error correction and a one-bit feedback to report successful decoding [130]. An information reconciliation protocol based on a rate compatible LDPC code construction was proposed in [139].

3) SUMMARY

Reconciliation efficiency is one of the most commonly used metrics, which is inversely proportional to the bit leakage rate. However, there is a paucity of literature on the interaction delay and computational complexity, which should be considered, in particular in case of IoT devices having limited resources.

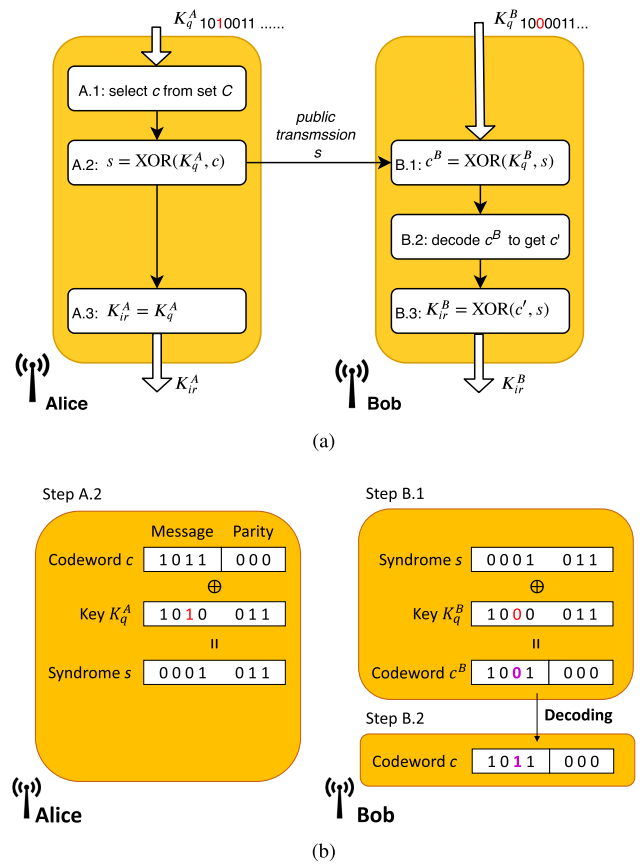

FIGURE 19. Information reconciliation, secure sketch. (a) Flow chart. (b) Error correction process.

Li *et al.* proposed a new hybrid information reconciliation protocol integrating the BBBSS protocol and BCH codes [140]. Their objective was that of maximizing the proportion of corrected bits per unit time, whilst making a trade-off amongst the conflicting performance indicators of information leakage, interaction delay and computational complexity. Future work should take into consideration these metrics and improve reconciliation performance.

On the other hand, the work in [141], [142] designed key generation protocols without using information reconciliation. Alice encrypted the information bits with the unreconciled keys using XOR operation. The encrypted bits received by Bob may be affected by the transmissions errors and channel coding and decoding are usually used to achieve successful transmission. The concept is inspired that the FEC is used to correct the transmission errors anyway and the key mismatch between Alice and Bob can be corrected together with the transmission errors. However, this approach is not applicable when a non-XOR encryption is used.

D. PRIVACY AMPLIFICATION

Alice and Bob have to exchange information over a public channel during the previous steps, including preprocessing, quantization and information reconciliation. Unfortunately,

Eve may be able to infer the secret key from these interactions. For example, a 2-bit syndrome leaked during the information reconciliation phase will narrow the search space to be explored by Eve by a factor of four. Hence Eve may find the key much quicker. As a countermeasure, privacy amplification allows Alice and Bob to distill a shorter but almost completely secret key from a common random variable about which Eve has acquired partial information [143]. This process is commonly implemented by using so-called universal hash families, which can be used for compressing keys, such as the leftover hash lemma of [70], [144], the cryptographic hash functions (e.g., secure hash algorithm) of [132], [145] and the Merkle-Damgard hash function [63].

According to the leftover hash lemma [70], [144], when an adversary knows t_k bits of a n_k -bit sequence, Alice and Bob can produce a key of length $L = n_k - t_k$ bits, over which Eve has almost no knowledge [146]. Considering the MD5 protocol as an example that maps a data string of arbitrary length to a data string of $L = 128$ bits, we have

$$\Phi : \{0, 1\}^{n_k} \rightarrow \{0, 1\}^L. \quad (16)$$

In order to apply the MD5 hash function Φ , Alice and Bob have to calculate the input sequence length n_k . Assuming that the information leakage ratio is η , the length of the secret key, L , is given by definition as

$$L = n_k(1 - \eta). \quad (17)$$

Thus, in order to produce a secret key having a length of L bits, Alice and Bob should generate at least

$$n_k = \lfloor \frac{L}{(1 - \eta)} \rfloor \quad (18)$$

bits as their common random sequence, where $\lfloor \cdot \rfloor$ represents the floor operation.

The input sequence of the privacy amplification should have a uniform random distribution, otherwise, it will result in a weak key. Considering again MD5 as an example, the output of the MD5 function may pass the random test even when there are long runs of 0s and 1s in the input. However, this property leaves MD5 vulnerable to so-called dictionary attack. This can be enhanced by randomness extractors, i.e. by transforming biased probability distributions representing weak random sources into near-uniform probability distributions [147]–[149].

For high-speed real-time key generation systems, the imposed delay by privacy amplification is one of the limitations, which may be reduced by resorting to the techniques advocated in [150]–[152].

E. SUMMARY

Having completed the four stages in Fig. 12, Alice and Bob will generate the same key. The key generated can then be used, wherever a common session key/password is required. Some applications of these techniques have been reported, including physical layer encryption [153], building a so-called 1-out-of-2 oblivious transfer [154], a cross-layer

password-authenticated group key exchange protocol [155], [156], the design of spreading codes for spread spectrum communications [157], assisting the preloading of 6LoWPAN nodes wirelessly [158], [159] and a hybrid Merkle Puzzle-based key agreement scheme conceived for smart home applications [160].

V. DESIGN CONSIDERATIONS AND PERFORMANCE OPTIMIZATION

This section will introduce the relevant design considerations and possible methods to optimize key generation performance. We will first introduce the pertinent channel parameters, including the received signal strength indicator (RSSI) and CSI. We then review the different signal domains, namely the temporal, frequency and spatial domains. Finally, the duplex modes such as TDD, FDD and IBFD modes will be discussed.

A. CHANNEL PARAMETERS

The channel parameters are the most important characteristics used for key generation, since they represent the channel's randomness. The most popular parameters are the RSSI and CSI. The latter can also be further divided into CIR and CFR.

1) RECEIVED POWER/RSS/RSSI

These three terms, namely the received power, received signal strength (RSS) and RSSI, are used interchangeably in this paper. RSSI is used in almost all the wireless techniques to represent the link quality and it is also made public to the users, for example in the IEEE 802.11, IEEE 802.15.4, Bluetooth and LoRa, etc. This section will reveal the technical details of the RSSI-based solutions in different standards and their calculation in the real transceivers.

The received power is mathematically defined in (4), but its calculation is more complicated in real transceivers. For example, the IEEE 802.16 standard specifies RSSI as (Section 8.3.9.2, [161])

$$RSSI = 10^{-\frac{G_{rf}}{10}} \frac{1.2567 \times 10^4 V_c^2}{(2^{2B})R_i} \left(\frac{1}{N} \sum_{n=0}^{N-1} |y_I[n]| \right)^2, \quad (19)$$

where B , R_i and V_c are the ADC precision, input resistance and input clip level, respectively. Furthermore, G_{rf} is the analog gain between the antenna connector and the ADC input, $y_I[n]$ is the n^{th} sample of the inphase branch of the signal, and N is the number of samples.

IEEE 802.11 defines RSSI as a relative measure of the received power, with a range spanning from 0 to RSSI maximum (Section 18.2.3.3, [34]). However, different manufacturers may interpret the RSSI in different manners. For example, the RSSI maximum values of Cisco and Atheros are 100 and 60, respectively. Additionally, MAX2829, a WiFi transceiver, reports the RSSI in voltage [162]. It is very common in practice that the transmitter and receiver use different NICs and transceivers. However, because Alice and Bob quantize the measurements individually and independently,

their heterogeneous devices are unlikely to have an impact on their key generation [163].

The RSSI is also available in the IEEE 802.15.4 standard. The CC253x, a TI ZigBee radio, calculates the RSSI by averaging the power received over eight symbol periods (128 μ s) [100]. The RSSI reflects the signal strength, but not necessarily the link quality, since both the interference and noise will increase the signal strength. Therefore, IEEE 802.15.4 defines the link quality indicator (LQI), which characterizes both the signal strength and signal quality [35]. The CC253x calculates the LQI by

$$LQI = (CORR - a) \times b, \quad (20)$$

where CORR is calculated by correlating the incoming frame with the first eight symbols following the start of the frame delimiter field, which ranges from 50 (lowest quality) to 110 (best quality), while a and b is chosen empirically. It would be interesting to explore how the LQI parameter may be exploited for improving the key generation performance.

The LoRa standard specifies a very high receiving sensitivity level of -148 dBm. The Semtech LoRa family of $sx127x$ exploits both the instantaneous RSSI value in the register RegRssiValue ($Rssi$) and the packet RSSI value in the register RegPktRssiValue ($PktRssi$) (Section 5.5.5, [164]). The latter is an averaged version of the former. Additionally, the RegRssiValue is usually smoother than the RegPktRssiValue. When LoRa operates above 779 MHz, the RSSI is calculated as [164]

$$RSSI = \begin{cases} -157 + Rssi, & SNR \geq 0; \\ -157 + PktRssi + PktSnr * 0.25, & SNR < 0. \end{cases} \quad (21)$$

As discussed above, the RSSI is available in almost all the wireless techniques and it is provided by the COTS transceivers. However, it is left to the vendors to decide about its specific calculation method. Additionally, since the RSSI is averaged over the entire packet, it is a coarse-grained parameter. Hence the resultant KGR is usually limited. Finally, Jana *et al.* [70] found that the RSS-based key generation is vulnerable to predictable channel attacks.

2) CSI

Compared to the RSSI, CSI is a fine-grained parameter, which can provide more valuable channel information. The CSI can be categorized into CIR, $h(\tau, t)$, and CFR, $H(f, t)$. Both are complex-valued, hence they have phase and amplitude, or real and imaginary parts. A multipath channel modelling technique was proposed for key generation in [59], which demonstrates that both CIR and CFR are beneficial sources of randomness. An entropy extraction technique based on the CIR was conceived in [165].

The amplitude of the complex-valued CIR is exploited by the UWB systems [166]–[171]. By contrast, the channel phase was used for key generation both in wideband systems [172], [173] and in narrowband systems [133], [174],

[175]. Compared to the amplitude, the phase has an extra pair of more attractive key generation features. Firstly, the phase is accumulative, which has inspired interesting applications, such as group and cooperative key generation [174], [175]. Secondly, the phases of all the channel paths, namely ϕ_l^{uv} in (2), are distributed uniformly across $[0, 2\pi]$, regardless of the power. Yet, the phase is vulnerable to noise, carrier frequency offset and asynchronous clocks/clock drift at the receiver, hence it is less suitable for practical applications [176]. The study in [133] is the only one on a practical phase-based key generation system, which is implemented on the USRP [177].

As shown in (6), the CFR represents the channel response in the frequency domain, which can be readily estimated by OFDM systems. An example is given in Fig. 20, and the CFR is generated based on the configuration of the IEEE 802.11 OFDM system with 20 MHz channel spacing. Based on (5), the channel estimation can be formulated as

$$\hat{H}^{uv}(f, t) = \frac{Y(f, t)}{S(f, t)} = H^{uv}(f, t) + \hat{w}^v(f, t). \quad (22)$$

As mentioned earlier, OFDM has been widely used in the IEEE 802.11a/g/n/ac/ax standard family. Taking IEEE 802.11 OFDM with 20 MHz channel spacing as an example, there are 52 subcarriers out of 64 subcarriers in the long training symbol; the training symbols use publicly known pilot sequences, thus the receiver can use them for channel estimation. The channel responses of individual subcarriers are modelled in [60], which analyzes its autocorrelation and cross-correlation relationship.

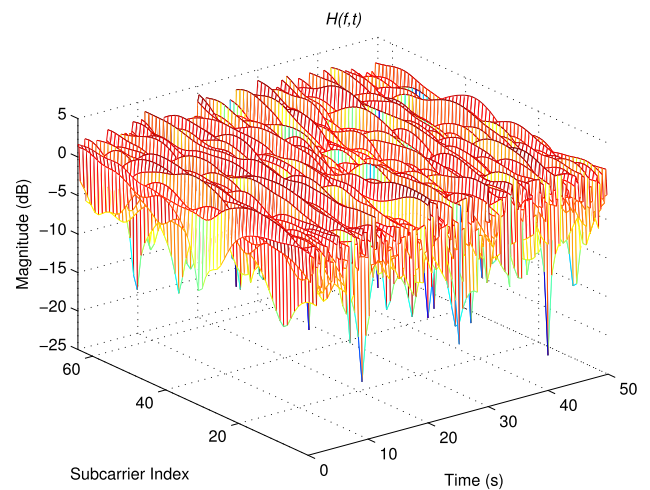

FIGURE 20. CFR with time and frequency variation in IEEE 802.11 OFDM systems.

The CSI represents fine-grained channel information, which can significantly improve the KGR [73], [178]. It is also immune to predictable channel attacks. However, the majority of the COTS NICs do not make the CSI publicly available, which limits its current adoption. There are two exceptions, however, namely the Linux CSI tools for the Intel

5300 NIC [179] and the Atheros NICs [180].³ Alternatively, specialized hardware platforms can be used, such as USRP, WARP, etc. However, these platforms are expensive, therefore they are only used for prototyping and experimenting.

Apart from the above OFDM-based applications, a chaotic signal-based key generation was proposed in [181] for transmissions over frequency-selective fading channels. The channel effects are characterized by the difference between the spectrum of the received signal and that of the transmitted chaotic signal. After the initial synchronization, both users can indeed generate the same transmitted signal, albeit it is not clear how to share the initial value for the first time.

3) SUMMARY

A summary of RSSI-based and CSI-based key generation techniques is given in Table 8, including the channel parameters, the related wireless techniques and testbeds, as well as the representative contributions, advantages and disadvantages. Generally speaking, the RSSI is usually readily available, but it tends to result in a low KGR due to its coarse-grained nature. On the other hand, solutions relying on the CSI typically have a better performance, but the application is usually limited to a few NICs and specialized devices.

B. SIGNAL DOMAIN

As shown in Fig. 21, the characterization of the wireless channel relies on three domains, namely the temporal, frequency and spatial domains. Each domain tends to exhibit randomness, which can be exploited for key generation.

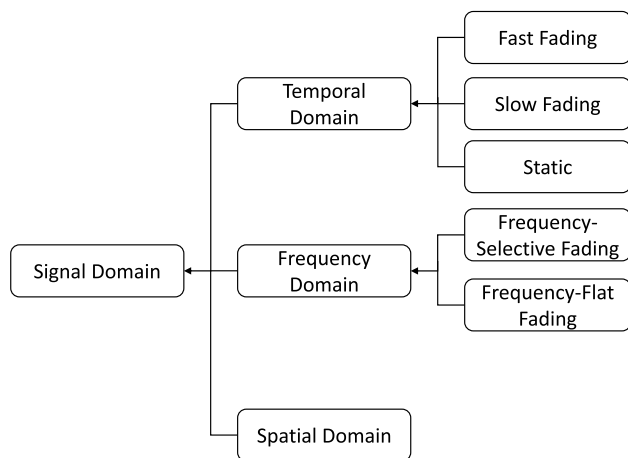

FIGURE 21. Signal domains.

1) TEMPORAL DOMAIN

The movement of objects and any reflectors as well as scatterers in the environment will affect the propagation path, which will cause unpredictable channel variation. The coherence time is defined as the duration over which the channel envelope remains near-constant, which was found empirically to

be [182]

$$T_c = \frac{0.423}{f_d} = \frac{0.423c}{vf_c}, \quad (23)$$

where f_d is the Doppler spread, c is the speed of light and v is the moving speed. When the coherence time is longer than the symbol period, the channel undergoes slow fading; otherwise, fast fading will occur.

a: SLOW FADING

Considering a pedestrian scenario at a walking speed of $v = 1$ m/s, and a 20 MHz WiFi system operating at $f_c = 2.4$ GHz, the coherence time is $T_c = 52.6$ ms, while the symbol length of is $\frac{1}{20 \times 10^6} = 0.05 \mu\text{s}$. The symbol length is much lower than the coherence time, which indicates a slow fading channel. This is often the case for many WiFi-based and IEEE 802.15.4-based key generation applications.

When the channel is fluctuating at a near-constant rate, it obeys a *wide sense stationary* (WSS) random process. Zhang *et al.* modelled the autocorrelation function of the CIR and CFR based on a WSSUS channel model [60], and found that the frequency response of individual OFDM subcarriers is also a WSS random process. This indicates that a fixed sampling interval can be used for both the CIR and CFR in WSS channels. Their findings were experimentally validated in different environments in [74].

However, the channel is not necessarily fluctuating at a fixed rate, hence a constant probing rate tends to result in inefficiency. Therefore, adaptive probing was proposed for addressing this issue by adjusting the channel probing rate for accommodating the channel variations in real-time [63]. Explicitly, a proportional-integral-derivative-based algorithm was designed for exploiting the RSSI variation. Channel probing is first mathematically modelled in [63] and it is then validated by experiments conducted at different speeds, mobility types and sites, using COTS WiFi hardware.

b: FAST FADING

Key generation requires correlated two-way measurements, which will be adversely impacted by fast fading. Hence research efforts have to be invested in conceiving key generation techniques for fast fading environments, in particular vehicular communications [183]–[185]. Considering a vehicle driving at $v = 60$ km/h and $f_c = 5.9$ GHz as an example, the coherence time is 1.3 ms. The shortest airtime of a 20 MHz channel spacing IEEE 802.11 packet is $34 \mu\text{s}$. The sampling interval, consisting of the packet airtime and short interframe space (SIFS) (more details can be found in Section VI-A1), is not negligible any more compared to the coherence time, which adversely affects the cross-correlation of measurements.

Zhu *et al.* tested key generation in vehicular scenarios at speeds up to 80 km/h using a WiFi Atheros chipset-based testbed [184]. They found the RSSI measurements very noisy, therefore, smoothing and level-crossing algorithms were used. They furthermore proposed an online parameter

³PCI-e interface is required for these NICs.

TABLE 8. RSSI-based and CSI-based key generation systems.

Parameter	Technique	Testbed	Representative Contribution	Advantage	Disadvantage	
RSS	IEEE 802.11	All COTS WiFi NICs	[63], [69], [70], [72], [144], [163]	Availability in most standards and transceivers	Various interpretation by manufacturers Vulnerable to predictable channel attacks Coarse-grained channel information	
	IEEE 802.15.4	Sensor nodes such as MICAz, TelosB	[62], [67], [68], [134], [135]			
	LoRa	LoRa transceivers	[77]–[79]			
	Bluetooth	Smartphone	[76]			
CSI	CIR, amplitude	UWB	Constructed by oscilloscope and waveform generator	[166]–[170]	Immune to the predictable channel attack Fine-grained channel information	NOT currently available in most commercial transceivers
	CIR, phase	Simulation	NA	Wideband systems [172], [173]; Narrowband systems [174], [175]		
		FM radio signals	Customized platforms, USRP	[133]		
	CFR, amplitude	IEEE 802.11 OFDM	Intel 5300 NIC	[73], [178]		
Customized platforms, USRP and WARP			[74]			

learning mechanism for adjusting the level crossing to the channel conditions. A KGR of 5 bps was finally achieved.

c: STATIC ENVIRONMENT

Another extreme case is the static environment, where the channel remains near-constant over time and no randomness can be provided. The limited randomness renders key generation challenging, hence innovative solutions have been proposed for introducing artificial randomness or using reconfigurable antennas.

Artificial randomness can be introduced by either the keying parties or by helpers [131], [186], [187]. A virtual channel is created in [186]. Alice is equipped with two antennas and controls the amplitude and phase of each symbol on each antenna. A helper node is introduced to broadcast jamming signals for varying the channel status in a static environment, but the jamming information is shared with Alice through a secure channel [131].

Using a reconfigurable antenna is another potential solution [66], [188]. An electronically steerable parasitic array radiator (ESPAR) antenna was designed having $N_a = 7$ elements [66]. The number of available beam patterns was $(2^8)^{N_a-1} = 2^{48}$. The RSSI profile will change when a beam pattern is randomly selected to provide suitable randomness even in static environments.

However, the above solutions are not entirely general, because either helpers or additional reconfigurable resources or multiple antennas are required.

Gollakota and Katabi [189] designed a friendly jamming-based key exchange system, termed as iJam. The transmitter generates a random sequence referred to as a *salt*, which is modulated onto OFDM symbols. The transmitter will send two copies of the OFDM symbol back-to-back. The receiver will randomly jam one of the symbols, namely either the original one or its repetition. Because the receiver knows

which symbol it has deliberately jammed, it can still decode the salt, but eavesdroppers cannot. The system has achieved 3 - 18 kbps KGR at a low KDR. However, the iJam system is different from the key generation concept, as it is not generating keys from the channel any more.

2) FREQUENCY DOMAIN

In a multipath environment, the signals undergo frequency selective fading. The coherence bandwidth, B_c , is defined as [190]

$$B_c \approx \frac{1}{\sigma_\tau}, \tag{24}$$

where σ_τ is the root mean squared (RMS) delay spread imposed by the multipath propagation. When the signal bandwidth, B_s , is higher than B_c , it is a frequency selective fading channel. Otherwise, it is a frequency flat fading channel. For example, experimental results indicate that the RMS delay is above 100 ns in the 2.4 GHz indoor environment [191], hence the coherence bandwidth is

$$B_c \approx \frac{1}{\sigma_\tau} < 10 \text{ MHz}. \tag{25}$$

For an IEEE 802.11 20 MHz channel spacing OFDM system, the signal bandwidth of $B_s = 20 \text{ MHz}$ is wider than B_c , and thus the channel is frequency selective. Frequency selective channels exhibit increased randomness, which is desirable for key generation.

The randomness of the frequency domain can be exploited by wideband systems. A number of OFDM-based key generation systems have been reported in [59], [60], [73], [109], [178]. The multipath channel is modelled in [59], [60] while the frequency domain autocorrelation is also modelled in [60], where nine out of 52 subcarriers can be used for producing random keys. Liu *et al.* [73] designed an IEEE

802.11n-based key generation technique and achieved a substantial KGR, namely 90 bits per packet.

The frequency domain randomness can also be exploited in narrowband systems by channel hopping [67], [192], [193]. For example, the bandwidth of IEEE 802.15.4 is much narrower than that of IEEE 802.11 OFDM. However, it has 16 channels in the 2.4 GHz band, with 5 MHz channel spacing between adjacent channels. Wilhelm *et al.* generated 50 bits from 16 IEEE 802.15.4 channels in a static but frequency selective channel [67]. They proved that a 160-bit key can be generated if the number of IEEE 802.15.4 channels is increased to 40.

3) SPATIAL DOMAIN

Multiple antenna techniques exploit the spatial diversity and have significantly improved the attainable key generation performance.

The family of MIMO schemes may be used for improving the KGR by exploiting the channel randomness in the spatial domain. Wallace *et al.* [58] derived the SKR for MIMO-based key generation schemes and evaluated their attainable performance both by simulation and indoor measurements. Chen *et al.* [110] investigated the performance of decorrelation techniques in eliminating the temporal and spatial correlation in MIMO systems. Quist and Jensen [194]–[197] conducted a systematic study of SKR maximization for MIMO-based key generation by optimizing both the beamforming vectors and the power allocation of the antenna elements.

MIMO-based key generation has been prototyped for the IEEE 802.11n standard. Zeng *et al.* [72] specifically designed an RSS and MIMO-based key generation system, which achieved four times higher KGR with the aid of three antennas compared to a single antenna protocol. Liu *et al.* [73] exploited both the frequency and spatial domain diversities simultaneously by using MIMO OFDM.

Multiple antennas can also be used for creating directional beams for randomizing the channel directions to mitigate the temporal correlations in static environments [198]. An ESPAR antenna can also be used for beamforming [66]. Precoding is another method of randomizing the signal and assisting key generation [199].

It is worth mentioning that MIMO solutions can also be used for multi-user access. IEEE 802.11ac supports downlink multi-user access, while IEEE 802.11ax enables both uplink and downlink multi-user access. Zhang and Knightly [200] demonstrated that the CSI in multi-user MIMO systems can be inferred either using explicit or implicit feedback. However, special techniques are required for multi-user MIMO-based key generation.

C. DUPLEX MODE

There are three basic duplex modes for wireless communication systems, namely TDD, FDD and IBFD, as illustrated in Fig. 22. Key generation meets different challenges when it is applied to practical communication systems operating in these modes.

1) TDD MODE

TDD refers to duplex communication links, where the uplink is separated from the downlink by the allocation of different time slots in the same frequency band. It is widely used in many systems, including WiFi, ZigBee, Bluetooth, LoRa, Long Term Evolution (LTE)-Advanced, and in the emerging 5G new radio mobile networks. In TDD systems, channel reciprocity is exploited for facilitating adaptive transmission to improve the system performance without any feedback overhead.

Fig. 22(a) illustrates the TDD-based channel sampling procedure, where Alice and Bob are allocated different time slots namely t_a and t_b for uplink and downlink channel probing at the same frequency f_1 . Eve observes the channel between her and Alice at time t_a over frequency f_1 and observes the channel between her and Bob at time t_b over frequency f_1 . The time delay Δt includes the time of packet transmission and the time of switching from transmitting to receiving.

The sampling delay affects the cross-correlation of the measurements in TDD systems. Zhang *et al.* [61] systematically study a practical scenario by taking into account all relevant parameters including the sampling delay, the eavesdroppers' location, the qualities of the legitimate and eavesdropping channels, the Doppler spread and pilot length. Their findings indicate that it is possible to tune the SKR by carefully designing the sampling delay and pilot length. For fixed sampling delays, interpolation filters can be employed to interpolate the value of a signal at unobserved points that lie in between two known samples [62], [134]. The reciprocity of interpolated measurements is typically improved and the effect of the normalized Doppler frequency on the correlation coefficient is also reduced.

The effect of sampling delay imposed on the channel correlation relies on whether the sampling time delay Δt is smaller than the coherence time T_c . In a slow fading channel with pedestrian walking, the coherence time is about 50 ms. By contrast, Δt can be configured to be on the order of μs . For example, $\Delta t = 60 \mu s$ is achieved in a WiFi system [60], [201], hence the channel's cross-correlation is only modestly impacted by non-simultaneous measurements in this case. Thanks to the channel reciprocity of TDD, most of the existing key generation implementations are realized in the TDD mode, as exemplified by employing WiFi [201]–[203], ZigBee [204], Bluetooth [76], UWB [166], and LoRa [77]–[79].

However, the sampling delay may have a significant impact, when it becomes comparable to the coherence time. In fast fading channels associated with high mobility objects, the coherence time becomes very short. For example, the terminals move fast in scenarios associated with moving robots, vehicles, high speed trains, drones, etc. Additionally, since the sampling time delay increases with the number of antennas and users, it might become longer in multi-antenna and multi-user scenarios. Finally, this could occur even in slow fading channels. For example, LoRaWAN specifies a one second delay between the uplink and downlink transmissions, which is much longer than the coherence time in slow fading

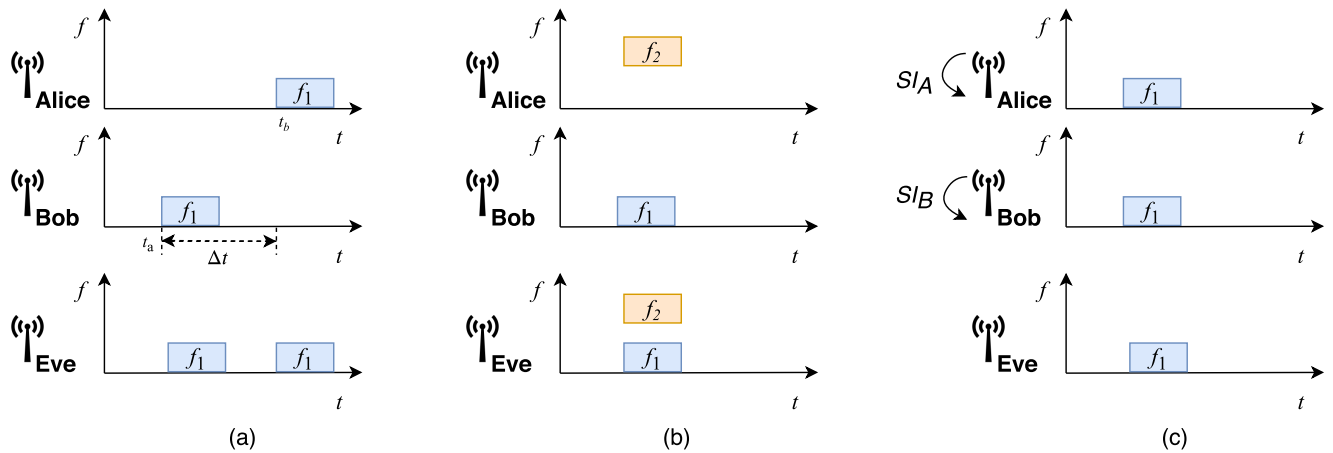

FIGURE 22. Key generation channel sampling with the (a) TDD mode, (b) FDD mode and (c) IBFD mode. The packet represents the received packet at users.

channels (about 50 ms). Further theoretical and experimental investigations are required to address this issue.

2) FDD MODE

In the FDD mode, the uplink and downlink transmissions operate at different carrier frequencies simultaneously. Fig. 22(b) illustrates the FDD-based key generation, where Alice and Bob probe the channel at the same time at the carrier frequencies of f_1 and f_2 . Eve can observe both transmissions and then estimate the channel between her and Alice over frequency f_1 and the channel between her and Bob over frequency f_2 . In contrast to TDD systems, FDD systems are not affected by non-simultaneous sampling, hence they are eminently suitable for supporting high mobility communications.

However, the frequency separation between the uplink and downlink results in non-reciprocal channels in FDD systems. Most of the reciprocal channel parameters used in TDD systems, such as the RSSI, channel gains, envelope and phase, can be quite different in FDD systems, depending on the channel's coherence bandwidth.

The existing FDD-based key generation solutions can be broadly classified into two categories: loopback-based protocols and frequency-invariant parameter-based approaches. Loopback-based protocols establish combinatorial channels with reciprocal channel gains with the aid of an additional reverse channel training phase [205]–[207]. Alice and Bob use combinatorial observations, such as $X^A X^B$, to generate secret keys. However, these protocols may complicate the channel sounding process and have potential security issues, since passive eavesdroppers might succeed in capturing the entire transmissions [208].

Another family of solutions relies on frequency-invariant parameters, including the eigenvalue of the channel's covariance matrices [209], the multipath angle and delay [210], and the reconstructed CFR [211]. The channel's covariance matrices represent second-order statistics, which differ by

a fixed constant for the uplink and downlink [209]. However, they change slowly and the KGR is rather limited. The other two algorithms provide instantaneous reciprocal channel parameters, which are inspired by the fact that the propagation paths in the uplink and downlink are reciprocal in most FDD systems. The frequency spacing between the uplink and downlink sub-bands of LTE systems is much lower than the center frequency. For example, the center frequency of Band 1 (IMT) is 2100 MHz, while the duplex spacing is 190 MHz; the center frequency of Band 30 (WCS) used by AT&T in the United States is 2300 MHz, while the frequency spacing is only 45 MHz [212]. Field measurements disseminated in the literature have shown that the uplink and downlink transmissions travel along the same propagation paths and experience similar multipath clusters [213], [214]. If the channel parameters, such as the complex path gain, path delay and the angle of each individual path is accurately estimated from the pilot signals in one frequency band, the channel state in another frequency band can be calculated from these parameters based on the FDD channel model provided in [211].

However, the estimation accuracy is quite critical, because even small estimation errors may be magnified by the multiplication of the frequency difference between the bands. The required accuracy is not readily achievable for narrow bands and for single antenna systems. Nevertheless, both the operational and future wireless systems rely on increasingly higher bandwidths and more antennas, hence it becomes more suitable for key generation in FDD systems. But given the plethora of open issues, further studies are still required for accurately modelling and prototyping FDD key generation schemes.

3) IBFD MODE

IBFD has emerged as an attractive technique of increasing the throughput of next-generation wireless communication systems. Upon using IBFD, a wireless device is allowed to

transmit and receive simultaneously in the same frequency band. Fig. 22(c) illustrates the key generation relying on the IBFD mode, in which Alice and Bob probe the channel at the same time at the same carrier frequency. The self-interferences (SI) of Alice and Bob are denoted as SI_A and SI_B , respectively, which can be reduced close to the noise level using multi-domain SI suppression techniques [215]. Eve can only observe the superposition of messages between Alice and Bob.

The IBFD mode brings about some advantages for key generation. Firstly, it is not restricted by encountering the aforementioned non-simultaneous sampling in TDD systems and frequency separation in FDD modes. Secondly, it may provide a higher KGR given the same time- and frequency-domain resources. Finally, IBFD provides additional protection against Eve, because she will be confused by observing the superposition of simultaneous transmissions from Alice and Bob.

Several authors have studied key generation in the IBFD mode. Theoretical key generation approaches have been proposed for IBFD mode in [216], [217]. Practical key generation testbeds relying on the IBFD capability of USRP devices and near field communication (NFC) devices are demonstrated in [218] and [219], respectively.

4) SUMMARY

In TDD systems, the channel reciprocity is adversely impacted by non-simultaneous sampling. Under FDD operation, the channel responses are generally not similar, due to encountering different propagation paths. Although IBFD enables wireless users to transmit and receive simultaneously over the same frequency band, it imposes new challenges due to excessive self-interference. Table 9 lists the factors influencing the reciprocity and their countermeasures, the representative contributions, advantages and disadvantages of the TDD, FDD and IBFD modes for key generation.

VI. IMPLEMENTATION AND APPLICATION SCENARIOS

A number of key generation prototypes have been implemented in the context of IEEE 802.11, IEEE 802.15.4, Bluetooth, UWB, LoRa, etc. This section will review these key generation applications. Three case studies are then used for exemplifying the key generation resource requirement and its implementation details.

A. APPLICATION SCENARIOS

As discussed, the wireless transceivers measure the RSSI and SNR, which can be readily used for key generation. Hence, many key generation prototypes have been built for IEEE 802.11, IEEE 802.15.4 and LoRa. Some of the most representative contributions are summarized in Table 10.

1) IEEE 802.11

IEEE 802.11 is the most popular technique adopted for characterizing key generation. According to the IEEE 802.11 distributed coordination function-based MAC protocol, when

the receiver successfully receives a DATA packet, it should reply with an ACKnowledgement (ACK) packet after waiting for a SIFS time interval. This interval is $10 \mu\text{s}$ in the 2.4 GHz band and $16 \mu\text{s}$ in the 5 GHz band. The DATA and ACK packets are thus perfect for probing, since their transmission time interval is on the order of μs [74], which is very desirable to get a high measurements correlation between these instances.

All the WiFi features, namely the frequency diversity of OFDM [60], spatial diversity of MIMO [72] and multi-user access capability of OFDMA [75], have been leveraged to enhance the key generation performance. Explicitly, [69], [70] represent the seminal key generation research, which uses IEEE 802.11a/g and extracts keys from the RSSI. However, the KGR is rather limited, on the order of 1 bit per second (bps). Because the RSSI is coarse-grained, the KGR can be improved by exploiting diversity both in the frequency and spatial domains. Zeng *et al.* [72] designed a three-antenna key generation system based on IEEE 802.11n, which achieves four times higher KGR than a single-antenna system. The KGR can be further enhanced by using OFDM for exploiting the frequency diversity [73], [178]; Liu *et al.* achieved a KGR as high as 360 bit/pkt employing a 2×2 MIMO OFDM system (3-bit quantization is used) [73]. Finally, Zhang *et al.* [75] leveraged the multi-user access feature in the latest IEEE 802.11ax amendment, which enables the AP to simultaneously establish keys with multiple users.

2) IEEE 802.15.4

Similarly to the IEEE 802.11, IEEE 802.15.4 also uses the acknowledgement frame to confirm a successful reception, after waiting for the duration of an acknowledgement inter-frame spacing (AIFS). The length of AIFS is specified as 12 symbols in the standard (Section 10.1.3, [35]). For a data rate of 250 kps, each symbol contains 4 bits, and lasts $\frac{1}{250 \times 10^3} \times 4 = 16 \mu\text{s}$; AIFS thus lasts $192 \mu\text{s}$. The length of a typical IEEE 802.15.4 payload is between 30 to 60 bytes. The time interval is thus in the order of milliseconds and a high measurement correlation can be expected in a slow fading channel. Therefore, several prototypes and experiments are relying on IEEE 802.15.4 [221].

WSNs can be used for industrial and environmental monitoring. The sensors remain at the same place once deployed, hence the channel variation is very limited. Kreiser *et al.* [204] investigated key generation in an industrial environment associated with two moveable robot arms and a milling machine. Based on the experiments, the authors concluded that key generation does not work well in this kind of demanding scenarios. However, their conclusion is not entirely convincing, as it does not exploit the frequency selectivity of the channel at all. IEEE 802.15.4 is capable of operating across 16 channels at 2.4 GHz and legitimate users can switch their channel for exploiting randomness in the frequency domain [67], [222], as discussed in Section V-B2.

IEEE 802.15.4 is also widely used for body area networks (BAN) [223], [224], where the sensor nodes are mounted on the body. Hence in contrast to WSNs, usually sensor

TABLE 9. Key Generation for Different Duplex Modes.

Duplex Mode	Reciprocity Influence Factor	Countermeasures	Representative Contribution	Advantage	Disadvantage
TDD	Non-simultaneous sampling	Probing design, interpolation filter	[61], [62], [134]	Most of existing key generation implementations are realized in TDD	Low performance for faster moving scenarios
FDD	Frequency separation	Loopback based protocols, frequency-invariant parameters based approaches	[205]–[207], [209]–[211]	Support high speed scenarios	No experimental results
IBFD	Self-interference	Multi-domain SI suppression techniques	[216]–[219]	Full duplex, Higher key generation rate, Security	Potential debilitating effects of self interference

TABLE 10. Key generation prototypes and applications with different wireless techniques.

Paper	Year	Wireless Technique	Testbed	Parameter	Contribution
[69]	2008	IEEE 802.11a	FPGA-based platform and Atheros NIC	CIR, RSS	One of the first key papers to apply key generation with IEEE 802.11
[70]	2009	IEEE 802.11g	Intel 3945ABG NIC	RSS	Extensive experiments in different environments and mobility modes
[72]	2010	IEEE 802.11n	Intel 5300 NIC	RSS	Improving KGR by employing spatial diversity with multi-antenna
[73]	2013	IEEE 802.11n	Intel 5300 NIC	CSI	Improving key generation performance by using MIMO OFDM
[74]	2016	IEEE 802.11g	WARP	CSI, RSS	Evaluating key generation principles in different multipath environments including anechoic chamber, reverberation chamber and indoor office
[75]	2019	IEEE 802.11ax	Simulation only	CSI	Improving the efficiency of multi-user key generation by employing multi-user OFDMA
[66]	2005	IEEE 802.15.4	CC2420	RSS	One of the first key papers to apply key generation with IEEE 802.15.4; used a reconfigurable antenna (ESPAR)
[62]	2010	IEEE 802.15.4	TelosB	RSS	Investigating multi-bit quantization and signal preprocessing algorithms (filtering and decorrelation)
[67]	2013	IEEE 802.15.4	MicaZ sensor mote	RSS	Exploiting channel responses of a frequency-selective environment in a static wireless sensor network
[68]	2014	IEEE 802.15.4	MicaZ sensor mote	RSS	Evaluating key generation feasibility in body area network with different channel variations
[76]	2014	Bluetooth	Smartphones with Broadcom chips	RSS	The first paper to apply key generation with Bluetooth; Investigating key generation performance with Bluetooth under heavy WiFi traffic by using a very wide bandwidth and random frequency hopping
[166]	2007	UWB	Simulation	CIR	The first key paper to apply key generation with UWB; investigating the feasibility such as reciprocity and secret key rate
[169]	2010	UWB	Waveform generator and oscilloscope	CIR	Evaluating channel reciprocity and spatial decorrelation of UWB-based key generation
[171]	2015	UWB	Vector network analyzer	CIR	Evaluating key generation performance in indoor environment with LOS/NLOS
[220]	2016	UWB	Integrated IR-UWB devices	CIR	A UWB-based key generation prototype on a platform with the full protocol stack; Performance evaluation in the static, occupied and mobile scenarios
[77]	2018	LoRa	LoRa/GPS Shield with sx1276	RSS	Experiments in urban environment and deep in-building penetration; Using differential-based quantization to automatically adjust the channel variation
[78]	2019	LoRa	Multitech mDot with sx1272	RSS	Extensive experiments with different setups, such as mobile and static scenarios, indoor and outdoor environment
[79]	2019	LoRa	SX1276RF1JAS evaluation boards with sx1276	RSS	Experimentally evaluating effects of different LoRa parameters, such as spreading factor and bandwidth. Key generation validation with LoRaWAN protocol.

mobility is introduced by the host human. Hanlen *et al.* [225] demonstrated the randomness incurred by human activities, such as their movement in an office or running on a treadmill, which is sufficiently random for key generation. They achieved a KGR of 4 bps in theory and 2 bps by simulation. Ali *et al.* [68] evaluated the key generation performance in different scenarios. They considered

- high activity, where the host is working and walking,

- low activity, where the host is mainly sitting but occasionally moving,
- dynamic environment, where the devices are stationary but the surrounding channel is changing due to people walking around.

Their experiments demonstrate that key generation is feasible in all these three scenarios. They also show that it takes 15 to 35 minutes to generate a 128-bit key, when channel sampling is combined with the regular data transmissions but does

not require any dedicated communications. Li *et al.* [226] investigated the issues of group key generation in BANs. Four group models were proposed and then one of them was selected as an example for experimental evaluation.

3) BLUETOOTH

Bluetooth is operating at 2.4 GHz, which is an ISM band crowded by WiFi, ZigBee, etc. Therefore, Bluetooth divides the 2.4 GHz band into 79 channels and uses adaptive channel hopping (AFH) to avoid access collision. According to the specification, the slave will have to respond to the master on the same RF channel that is used by the master-to-slave transmission, which is known as the same channel mechanism of AFH (page 401, [36]). Additionally, the specification divides the physical channel into time slots, each with 625 μ s and each packet can occupy up to five time slots, namely 3.125 ms (page 387, [36]); thus the maximum transmission delay between the master-to-slave and slave-to-master phases is 3.125 ms. These two features are desirable and beneficial for key generation, as the bidirectional transmissions operate at the same carrier frequency and the sampling delay is small. A high correlation of the measurements can thus be obtained.

Surprisingly, there are very few papers that design key generation for Bluetooth and [76] is the first one. In this work, Premnath *et al.* considered a three-node scenario where Alice and Bob are exchanging information using WiFi and a node C wants to generate key with Alice. When the key generation probing is using Bluetooth, Node C first estimates the channel usage and then generates the frequency hopping sequence. Frequency hopping is beneficial, because in a wideband fading scenario, the different carriers may be deemed to fluctuate independently, hence a faded channel is followed by an unfaded one. The keying parties, Alice and the node C, will then exchange probing packets based on the hopping sequence. The authors also compared that of WiFi-based probing. They implemented both key extraction schemes on typical smartphones and carried out extensive experiments. Their results demonstrated that under heavy WiFi traffic Bluetooth key generation outperforms WiFi key generation, when Alice conveys heavy WiFi traffic.

4) UWB

Wilson *et al.* [166] are the first authors to apply key generation for UWB systems and they derived the SKR. The majority of the practical UWB-based key generation solutions in the literature relied on a system consisting of a waveform generator and an oscilloscope [167]–[170] or a vector network analyzer [171]. Nevertheless, these sophisticated facilities are quite expensive, thus they are only suitable for experimental verification. Researchers have carried out extensive experiments both in indoor and outdoor LOS and non-line-of-sight (NLOS) scenarios for validating the channel reciprocity and spatial decorrelation characteristics of UWB systems [167]–[171]. However, to avoid practical pitfalls, it is important to note that typically the higher the bandwidth, the less valid the reciprocity becomes.

There is an exception that uses an integrated IR-UWB device [220]. The device operates in the band of [4.25 4.75] GHz and can provide CIR estimation (real part) in the resolution of 1 ns. The device adopts the classical slotted ALOHA MAC protocol. In particular, the sampling delay between the pair of bidirectional measurements is 7.5 ms and the sampling interval can be 150.7 ms. The authors used a quantization algorithm for representing the CIR. Based on their evaluation in the static, occupied and mobile scenarios, the authors demonstrate that their system achieves a high grade of reciprocity as well as randomness and an acceptable KGR of 18 bps.

5) LoRa/LoRaWAN

In this specific context, key generation was only applied for short range communications, because the ranges of WiFi, ZigBee and Bluetooth are below 100 meters. Long range key generation was first reported in 2018 [77]–[79], [227] using LoRa, even though LoRa was standardized in 2015.

In contrast to WiFi or IEEE 802.15.4, several special issues are affecting key generation in LoRa/LoRaWAN, which are listed as follows.

- The packet duration of LoRa is much longer than that of WiFi, ZigBee and Bluetooth, ranging from milliseconds to seconds. Additionally, LoRaWAN specifies a Receive Delay parameter between the uplink and downlink, which is one or two seconds. These two factors result in a high sampling delay between the bidirectional measurements, which degrades the measurements' correlation.
- Because LoRaWAN uses the classic ALOHA MAC protocol without any channel sensing, there is usually an unavoidable duty cycle limitation for the LoRaWAN band. For example, the European Telecommunications Standards Institute regulates the ISM band's channel utilization and hence the duty cycle of the LoRaWAN band in Europe is limited to 1%. This will significantly decrease the number of exchanged packets, hence the average KGR is extremely limited.

For example, considering a 10-byte payload and a LoRa configuration associated with spreading factor of 7, bandwidth of 125 kHz and code rate of 4/5, the packet airtime is 41.22 ms [228]. Therefore, the (minimum) sampling delay is 1.04122 ms; the LoRaWAN end devices can only transmit a single packet every 4.122 seconds, in order to meet the duty cycle regulation.

LoRa/LoRaWAN-based key generation is still in its early stage of development. In order to evaluate the LoRa key generation performance, Xu *et al.* [78] carried out extensive experiments in different mobility modes (static or mobile), environments (indoor or outdoor), distances (up to 4 km), data rates and motion types (walking, biking, or driving). Their results demonstrated the feasibility of LoRa-based key generation.

Ruotsalainen *et al.* [79] evaluated the attainable key generation performance for different LoRa modulation parameters, including spreading factors and bandwidths. These parameters will determine the airtime of the LoRa packets, which is directly related to the measurement correlation. They found that the KDR will be too high for $SF > 10$. Additionally, both the instantaneous RSSI and packet RSSI are used and the former is found to have a better performance in terms of its cross-correlation and KDR. They have then further extended their work by implementing key generation for the LoRaWAN protocol. They experimentally demonstrated that LoRaWAN-based key generation is indeed feasible, even when Alice and Bob are located seven km away from each other with both devices static, hence only experiencing environmental variation.

Zhang *et al.* [77] applied differential value-based quantization to capture the channel variation both in an urban environment and deep in-building penetration. More explicitly, as shown in Fig. 14(b), the channel envelope may be varying from -123 dBm to -49 dBm in an urban test, but the consecutive samples are likely to be similar. Hence differential value-based quantization may be adopted for producing key sequences with high randomness and low KDR.

6) SUMMARY

Key generation benefits from TDD-based techniques because of the channel reciprocity. Fortunately, the majority of the wireless techniques support the TDD mode, including IEEE 802.11/WiFi, IEEE 802.15.4, LoRa, etc.

There are also some wireless techniques with no or very few key generation applications reported at the time of writing.

- *Cellular Networks*: There is one paper reporting LTE-based key generation with some preliminary results [229]. This is partly because fewer open platforms are supporting cellular networks.
- *FDD Systems*: FDD LTE and NB-IoT operate in FDD mode. As discussed in Section V-C2, the channel reciprocity in such systems is challenged and correlated measurements are difficult to obtain.
- *SigFox*: Key generation requires bidirectional measurements between Alice and Bob. However, SigFox, for example, only allows up to 140 messages per day, which results in very inefficient sampling; there will also be a delay of 20 seconds between the uplink and downlink messages [230], which significantly degrades the channel's correlation.

B. CASE STUDY

1) RESOURCE AND ENERGY ANALYSIS OF A ZigBee-BASED KEY GENERATION PROTOCOL

The key generation protocol of Zenger *et al.* [64] only involves low-complexity operations, leading to low energy consumption. Explicitly, Zenger *et al.* implemented their full ZigBee-based key generation protocol on both a 32-bit ARM

Cortex-M3 platform (EFM32GG-STK3700) as well as an 8-bit Intel MCS-51 (CC2531) chip, and calculated the resource and energy consumption. Additionally, a 32-bit [231] and an 8-bit [232] reference implementation of the elliptic curve Diffie Hellman (ECDH) key exchange, known as one of the most efficient PKC, were also realized for comparison.

The resources and energy consumption results are given in Table 11, where their key generation is seen to outperform ECDH. In particular, key generation requires much less computational resources than ECDH and it is much more energy-efficient. For example, when they are implemented in an 8-bit platform, ECDH requires about 8 times more code size, imposes 1289 times higher complexity, and consumes 98 times more energy than that of the key generation procedure of [64]. Since the key generation design is not optimized, it is expected that its resource and energy consumption can even be further reduced. Key generation is hence eminently suitable for IoT devices, constrained by their computational capability and battery power.

2) A WiFi-BASED DEMO WITH SPECIALIZED WARP HARDWARE

A key generation demonstration and testbed has been created at the University of Liverpool, UK. A demonstration video is included as the multimedia supplement material for this paper.⁴ The experimental setup and the associated graphical user interface are shown in Fig. 23 and Fig. 24, respectively. The demo is based on a specialized hardware platform, namely WARP boards [233], but it may also be readily ported to other wireless testbeds with the necessary changes made to the channel probing part. The protocol is implemented using the Python language.

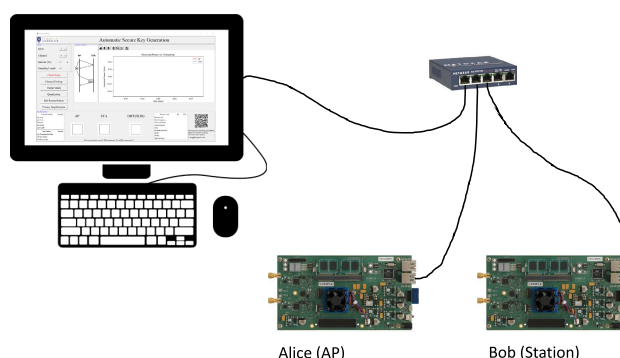

FIGURE 23. The setup of the key generation demonstration at the University of Liverpool, UK. Antennas for WARP boards are not shown for brevity.

The protocol implementation is detailed as follows.

- *Channel Sampling*: The WARP 802.11 Reference Design, which is compatible with commercial WiFi,

⁴This paper has supplementary downloadable material available at <http://ieeexplore.ieee.org>, provided by the authors. This includes an mp4 format video, which shows a WiFi-based key generation demonstration. This material is 58.8 MB in size.

TABLE 11. Energy and resources requirements of key generation protocols and ECDH.

Protocol	Platform	Resources		Energy		
		Code Size (kb)	# of Cycles	Computation (mJ)	Communication (mJ)	Total (mJ)
Key generation	32-bit ARM Cortex-M3	1.033	302,297	2.24	0.18	2.43
Key generation	8-bit Intel MCS-51	1.137	1,345,205	5.20	0.18	5.39
ECDH	32-bit ARM Cortex-M3	5.918	38,774,000	100.96	0.06	101.02
ECDH	8-bit Intel MCS-51	8.749	1,734,400,000	528.45	0.06	528.51

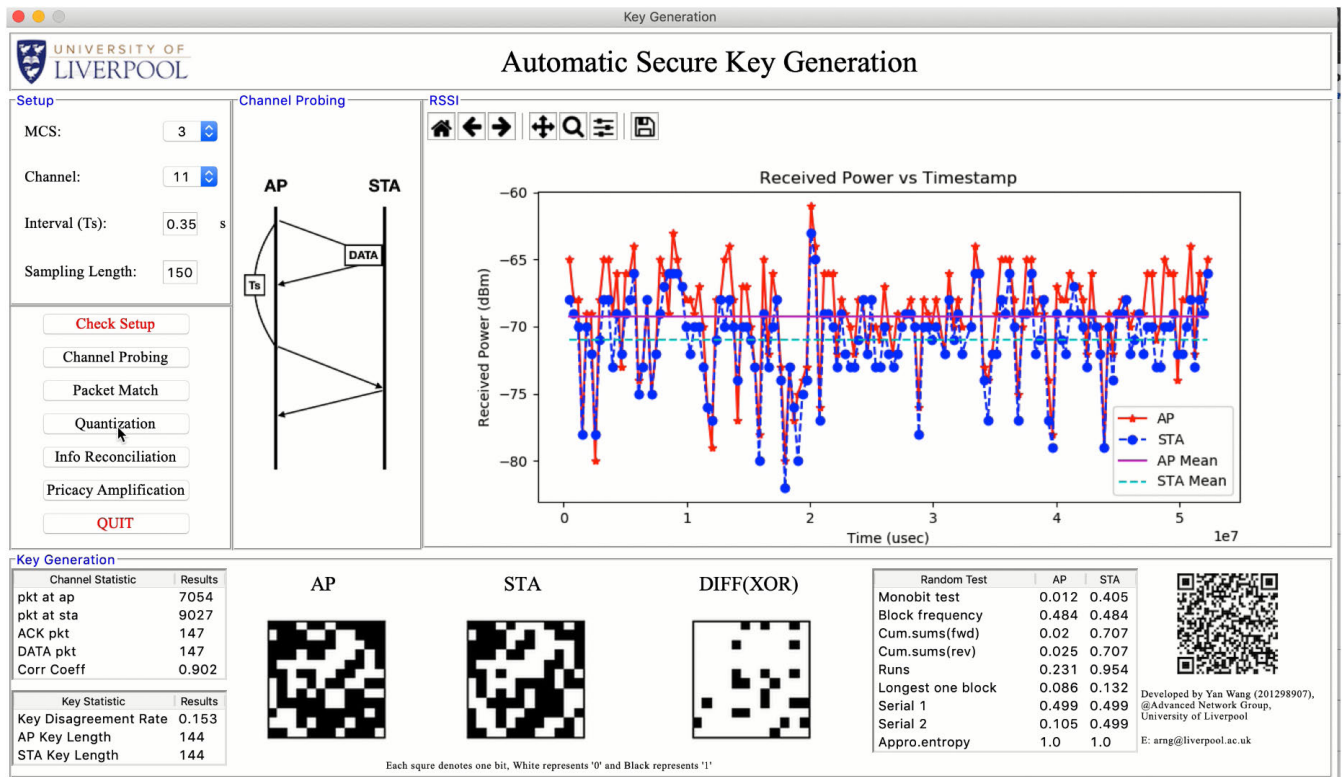

FIGURE 24. The graphical user interface of the key generation demonstration at the University of Liverpool, UK.

is used for accessing the WARP hardware [234]. The DATA packet and its corresponding ACK packet, which are standard WiFi packets, are used for bidirectional probing. The sampling delay between the DATA and ACK packets is configured as 64 μ s, therefore highly correlated received power measurements can be obtained.

- Packet Match: Because the testbeds will receive all the WiFi broadcast transmissions in the air, such as the Beacon frames of other WiFi networks, reliable packet selection is required for capturing the packets having the correct receiver MAC address. In addition, there may be packet loss events during the transmissions, resulting in inconsistency between the packets received by Alice and Bob. The difference between the timestamps of the paired DATA and ACK packets is 64 μ s in this demo. The packets are further refined by comparing their timestamps of the packets at Alice and Bob.

- Quantization: Mean value-based quantization is used as an example of converting the analog measurements into a binary sequence.
- Information Reconciliation & Privacy amplification: The BCH-based secure sketch [129] is adopted. The SHA256 hash function [235] is used for privacy amplification.
- Randomness Test: A python-based implementation of the NIST randomness test suite is used [108].

3) A WiFi-BASED IMPLEMENTATION USING COTS HARDWARE

Prophylaxe [236] is a German project aiming for creating practical wireless physical layer security for IoT, which was completed with great success.

Zenger et al. [237] created a key generation implementation using COTS WiFi platforms, namely a WRT54GL WiFi router and a Nexus 4 smartphone. The WRT54GL router is an open source hardware platform and SoftMAC [238] is

used for enabling channel measurements on a per frame basis. The NIC should also support a virtual monitor mode and raw packet injection, which will allow devices to perform communications even when they are not associated with a particular network. Radiotap header [239] is a particular header that is designed for some WiFi NICs to report the characteristics of the frames, including timestamps, channel, RSSI, etc.

Nexus 4 is partly open source hardware, which is produced by LG and Google. Root access to the file systems is required. An open-source WiFi FullMAC driver [240] is supported, but it is very complex. Fortunately, there is an experimental open-source project based on the SoftMAC driver, WCN36xx [241]. This is beneficial, since it allows the developer to integrate their manipulation in the same manner as for the router.

A full implementation is then performed. The channel measurements are carried out by using IEEE 802.11 management frames, namely the probe request and probe response frames [242]. Graphical user interfaces are created for both the router and the smartphone. It is also integrated into the WiFi WPA/WPS protocol. Experiments have been carried out both in stationary and mobile environments.

4) SUMMARY

The results and implementation aspects portrayed in this case study section are generally applicable to all the key generation protocols. However, when applied in different wireless techniques, such as WiFi or ZigBee, the channel probing will differ. By contrast, the remaining three steps, namely the quantization, information reconciliation and privacy amplification can be the same.

VII. KEY GENERATION WITH MULTIPLE PLAYERS

The previous sections only involved a pair of legitimate users, Alice and Bob. This section will extend these concepts to scenarios with multiple players, involving Alice, Bob and third parties. The third parties may act as

- keying parties that wish to establish a common group key.
- relays that assist the key generation process;
- attackers that passively eavesdrop or actively disrupt the key generation process;

This section will cover all the above three scenarios.

A. MULTI-USER/GROUP KEY GENERATION

Key generation usually works between a pair of users by establishing a pairwise key between them. However, there is a clear need to establish keys among multiple nodes in some scenarios, where a number of users have to exchange confidential information.

1) STAR TOPOLOGY

Star topology-based networks are the most well investigated scenarios of multi-user/group key generation. Ye and Reznik [243] studied the SKR of group key generation

using graph theory. The existing protocols can be categorized into reference-channel based schemes and OFDMA-based schemes, as portrayed in Fig. 25.

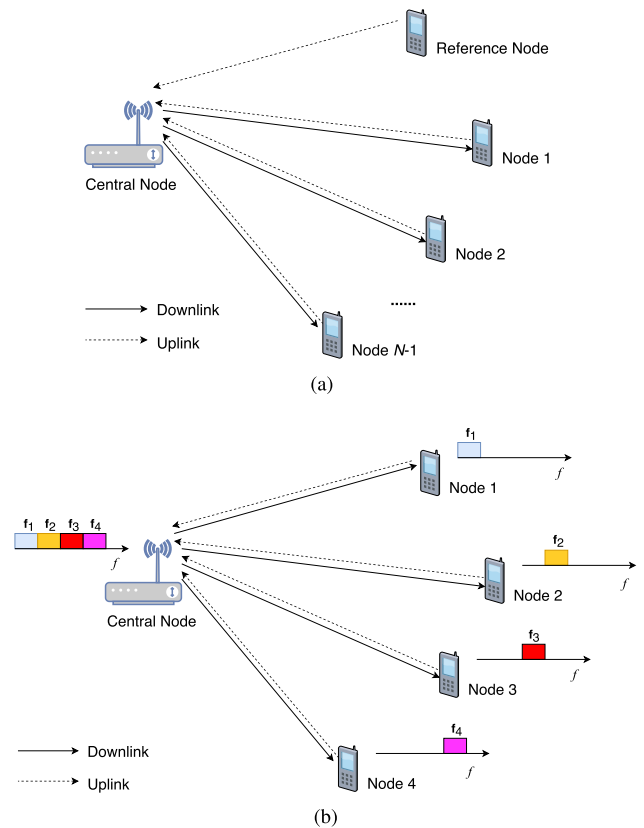

FIGURE 25. Group key generation in star topology-based networks. (a) Reference channel-based scheme. (b) OFDMA-based scheme. Four stations are given as an example.

As shown in Fig. 25(a), Liu *et al.* [135] proposed a reference-channel based scheme, which first randomly selects a central node, n_c , and then a reference node, n_{ref} . The RSS between the central and reference nodes, p_{ref} , is calculated and defined as the reference channel. By performing the bidirectional probing, the RSS of the downlink and uplink channels between the central node and the u^{th} node can be measured, which are denoted as p_{dl}^u and p_{ul}^u , respectively. After completing all the probing, the central node will calculate the difference of the signal strengths (DOSS) between the u^{th} uplink channel and the reference channel, namely

$$\Delta p^u = p_{ul}^u - p_{ref} \quad (26)$$

and then transmits Δp^u to the node. The u^{th} node then calculates

$$p_{dl}^u - \Delta p^u = p_{dl}^u - p_{ul}^u + p_{ref} \approx p_{ref}. \quad (27)$$

Thus, all the participating nodes will extract the common secret, namely p_{ref} . Xiao *et al.* [244] designed a similar scheme. They converted all the RSS values to binary keys first, k_{ul}^u and k_{dl}^u . Instead of calculating their DOSS, the central

node then calculates

$$\Delta k^u = k_{ul}^u \oplus p_{ref}. \quad (28)$$

The other operations are the same as those of the scheme in [135].

The reference-channel based scheme has to carry out pairwise channel probing between two users, which was found inefficient by the study of Jin *et al.* in pairwise-based multi-user key generation [245]. A pair of scheduling algorithms were discussed, namely serial and parallel probing.

Inspired by the desire of conceiving secure multi-user access, Zhang *et al.* [75] designed an efficient OFDMA-based multi-user key generation protocol and applied it to the latest IEEE 802.11ax standard as a case study. As shown in Fig. 25(b), the central controller and the nodes will share the subcarrier allocation information in advance. The central controller first broadcasts a downlink packet to all the stations, which carry out channel estimation. All the nodes will then commence their uplink transmissions simultaneously on their pre-allocated subcarriers, which will not cause inter-user interference. The central controller can then carry out uplink channel estimation for each user. A common key, k^u , can be generated between the AP and the u^{th} node. This scheme intelligently exploits the multi-user access technique and significantly reduces the channel probing overhead.

Once an individual key has been setup in multi-user key generation, Wei *et al.* [246] designed a group key distribution algorithm. The AP will generate the group key as

$$k_G = k^1 \oplus \dots \oplus k^N. \quad (29)$$

It will then mask the group key as $k_G \oplus k^u$ and transmit it to the u^{th} user. Finally, the u^{th} user extracts the group key by the exclusive-OR operation.

2) OTHER TOPOLOGIES

Group key generation protocols have also been conceived for other network topologies. Thai *et al.* [247] proposed a protocol for mesh topologies, but a pairwise channel probing was performed between different nodes. Wang *et al.* [174] designed a roundtrip-based protocol, where the nodes form a circle. Channel sounding was again carried out on a pairwise basis. However, the protocol relied on employing the channel phase, which limited its practical application. because accurate phase estimation is rather challenging. Xu *et al.* [248] maximized the group key rate for a ring network by studying the time required for channel estimation among all the users.

B. RELAY-BASED/COOPERATIVE KEY GENERATION

Key generation usually supports the interactions of a pair of users and thus it can only exploit the randomness of the link between them, which limits the amount of randomness and the communication range. In this scenario, the attainable performance can be improved by employing relaying/cooperating nodes for reaping the randomness between the legitimate users and relay, as shown in Fig. 26. For

example, there is typically a dominant LOS link between a pair of unmanned aerial vehicles (UAVs), resulting in a near-constant channel. A ground station can act as the relay and whilst still LOS-oriented, this relay-UAV channel usually has higher entropy than the direct LOS UAV-UAV channel, which can be exploited for key generation [249].

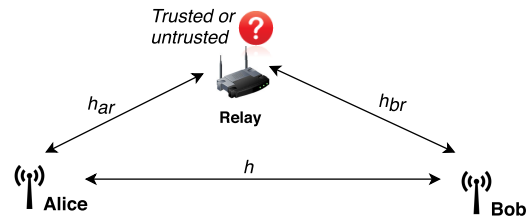

FIGURE 26. Key generation with a relay.

1) TRUSTED RELAY

Trusted relays will actively participate in the key generation process and share the randomness with legitimate users, which can thus significantly improve the key generation performance.

Lai *et al.* [250] proposed a cooperative key generation solution, where Alice, Bob and the relay node exchange packets with each other and separate keys can be established between each pair of users, namely k^{ab} , k^{ar} and k^{br} . The relay will then broadcast $k^{ar} \oplus k^{br}$; Alice and Bob can then get k^{br} and k^{ar} , respectively. Since Eve also gets $k^{ar} \oplus k^{br}$, Alice and Bob will use either (k^{ab}, k^{ar}) or (k^{ab}, k^{br}) as their key. The channels between the relay and the legitimate users are then exploited. The scheme was then also further extended to multiple relays.

Based on the same cooperative model, Wang *et al.* [251] derived the upper and lower bounds of the SKR in the face of a passive eavesdropper. The authors investigated a practical system relying on classic modulation schemes, such as PSK or QAM. Finally, they optimized the protocol for achieving tight bound of the SKR.

Shimizu *et al.* [252] designed relaying-aided schemes, namely an amplify-and-forward scheme, a signal-combining amplify-and-forward scheme, a multiple-access amplify-and-forward (MA-AF) scheme, and an amplify-and-forward with artificial noise scheme. They showed by their simulations that the MA-AF scheme has the best performance of SKR.

However, the above body of literature was based on single antenna systems. The authors of [253] and [254] further extended these ideas to MIMO relays and investigated the power sharing amongst the antennas. In particular, Chen *et al.* [254] found that their proposed power allocation scheme improves the SKR from 15% to 30% at low power, when compared to equal power allocation.

In some special cases, the node is not directly participating but only assisting in the key generation process, for example, by transmitting artificial interference for improving the

channel's randomness. This is particularly helpful in static environments [131], as mentioned in Section V-B1.

2) UNTRUSTED RELAY

On the other hand, security concerns arise when the relay is untrusted. An untrusted relay will help the key generation process, for example by forwarding messages, but potentially only owing to its desire to reveal the keys generated. Special measures should thus be taken.

Thai *et al.* [255] investigated scenarios with non-colluding, partially colluding and fully colluding relays, where all the users are equipped with multiple antennas. They concluded that key generation is feasible even in the face of fully colluding relays. They also found that there exists an optimal number of antennas for the untrusted relays.

Waqas *et al.* [256] borrowed the concept of social relationships to model the relay nodes. In particular, they modelled the actions of an untrusted relay as the social reciprocity relationship, where the user cooperation should be based on the mutual benefit. Coalition game theory was used to select the optimal relays.

In order to tackle the malicious actions of untrusted relays, a retrodirective array (RDA) was used by the relay nodes in [257]. Since the RDA acts similarly to a mirror, it will reflect the incoming signal by appropriately adjusting the phase conjugation, but it will not be able to store or decode the signal. Key generation will therefore be enhanced by the RDA owing to forwarding the messages, but imposing no threat.

C. ATTACKS AND COUNTERMEASURES

Similarly to classic wireless communications systems, key generation is also vulnerable both to passive eavesdropping and to active attacks. Passive eavesdroppers listen to all the key generation transmissions and endeavor to generate the same keys as legitimate users. On the other hand, active attackers aim for disrupting the key generation process. Some attacks are summarized in [82], but key generation attacks have received relatively limited research attention. This section will review the known attacks and their countermeasures.

1) PASSIVE EAVESDROPPING

The spatial decorrelation of received signals is based on Jakes' model, which indicates that the channel will be uncorrelated when a third party is located half-wavelength away [101]. The key generation performance under the Jakes' model can serve as a benchmark [61]. However, this model requires infinite and uniformly distributed scatterers around the user, which may not be the case in real environments.

Substantial research efforts have been invested into evaluating key generation security against passive eavesdropping both by simulation and experimental studies [74], [258]–[262]. He *et al.* [258] carried out comprehensive investigations on the link signature (LS)-based security, which mainly includes secret key generation and physical layer authentication [263]. They first investigated different

channel correlation models, including one-ring model, two-ring model, elliptical ring model and a far scatterer-ring model. These models were then evaluated by simulations. They have also carried out the experimental verification of the simulation results both in indoor and outdoor environments. Based on the simulation and experimental results, it was found that half-wavelength distance decorrelation is only valid in rich scattering environments.

Zenger *et al.* [260] created an automated antenna positioning platform for repeatable experiments, in order to evaluate both the cross-correlation and the mutual information of the legitimate users and eavesdroppers. Testbeds of the IEEE 802.15.4 standard operating at 2.4 GHz were used and the RSS was relied upon as the keying parameter. The authors found that cross-correlation between Alice and Bob is affected by Eve's antenna position when Eve is located within three wavelengths. This will help legitimate users to detect the presence of eavesdroppers by evaluating their channel correlation.

To expound further, Zhang *et al.* [74] carried out extensive IEEE 802.11 OFDM-based experiments at 2.4 GHz and at different multipath levels, including those conducted in an anechoic chamber (no multipath), in an indoor office (typical multipath) and in a reverberation chamber (very strong multipath). They found that neither CSI-based nor RSS-based key generation is secure, when there is no multipath propagation. On the other hand, key generation is quite secure in the face of strong multipath, as the eavesdroppers experience a channel that is uncorrelated with the legitimate link even when they are only a few centimeters away. Furthermore, it was observed that the eavesdropper's channel response varies significantly versus the distance, when they are within about two wavelength from the legitimate users in an environment having strong LOS (anechoic chamber). This observation indicates a limited validity of Jakes' model, which may due to the mutual coupling [264] and near field effects. Similar effects were also observed in UWB measurements [169]. Their experimental results indicated that it may not be optimal for eavesdroppers to locate too close to legitimate users.

2) ACTIVE ATTACK

In contrast to passive eavesdropping, active attackers aim for interrupting the key generation process by injecting jamming signals [265], man-in-the-middle (MITM) attack [266] and manipulative attack [267], [268].

Zafer *et al.* [265] introduced both a simple jammer transmitting at a fixed power and a smart jammer that can estimate channel. They defined a new efficiency metric that quantifies the minimum number of messages to be exchanged per secret key bit. They found that the key generation efficiency is dramatically reduced as a function of the jamming power. In terms of countermeasure, Belmega and Chorti [269] proposed to use channel hopping or power spreading; they also equipped the key generation parties with energy harvesting capabilities, which will harvest energy from the malicious jamming power.

Ebert *et al.* [266] designed a MITM attack poisoning the quantization stage and carried out the experimental validation of their solution using off-the-shelf hardware. They demonstrated that an intentional sabotage attack may indeed result in a high KDR and that Eve may acquire up to 47% of the generated key bits.

Jin and Zeng [267], [268] took a further step by conceiving a manipulative attack, which aims for forcing legitimate users to agree on some manipulated keys. More particularly, they designed a signal inject attack and a channel control attack. The authors later proposed a practical countermeasure, namely the PHYsical layer key agreement with User Introduced Randomness (PHY-UIR). The effectiveness of the method was validated both by simulations and experiments. However, the protocol was later found vulnerable in [270] to a session hijacking attack.

VIII. DEVICE AUTHENTICATION

A complete security system should meet the requirements of authentication, confidentiality and integrity. Confidentiality and integrity can be handled by encryption, which is assisted by the key generation process. However, key generation itself usually cannot be used for the authentication, hence existing key generation research simply assumes that both Alice and Bob are legitimate users.

Research attempts have been made to achieve both device authentication and key generation simultaneously in [271], [272]. However, the scheme proposed is only applicable to wireless BANs, where the devices should be mounted on the same person, which is not generally applicable.

Therefore, authentication techniques are necessary and this section introduces a complete wireless security architecture, which will achieve both device authentication and confidential transmission, as portrayed in Fig. 27. Some candidate techniques in this context are physical layer authentication and radio frequency fingerprinting (RFF)-based identification, as illustrated in Fig. 28. The former relies on the channel variations, while the latter is based on the random hardware features of wireless transceivers.

A. PHYSICAL LAYER AUTHENTICATION

Physical layer authentication constitutes another branch of physical layer security, which identifies the wireless devices based on the channel characteristics [273].

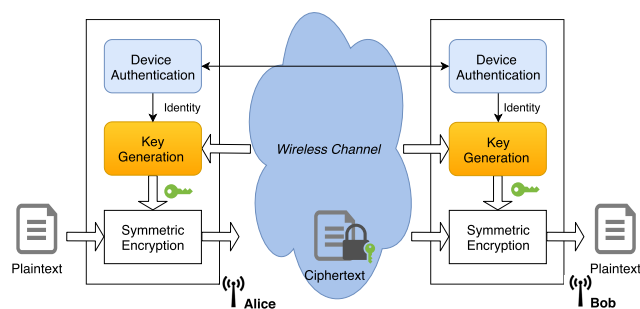

FIGURE 27. A full wireless security architecture consisted of device authentication, key generation and symmetric encryption.

Fig. 28(a) considers a scenario, where Alice is the transmitter and Bob is the receiver, who tries to authenticate if the signal is transmitted by Alice. Alice will transmit at a rate lower than coherence time, while Bob will continuously estimate the channel attributes, and compare their values to his previous records. When a pair of consecutive channel estimates are similar to each other, Bob concludes that the signal is indeed transmitted from Alice [274]. A spoofer, Eve, may impersonate Alice. According to the spatial decorrelation, the Eve-Bob link will have different channel features from the Alice-Bob link, when Eve is located at a certain distance away from Alice. Therefore, when Bob detects any anomaly of the received signal, it declares a potential hijack [275].

Similar to the key generation process, physical layer authentication has also been designed for exploiting different channel parameters, including the RSS [276], the CIR [277], the CFR [263]. Again, the CIR and CFR usually provide better authentication reliability, because they are fine-grained. Since the channel fluctuates unpredictably, machine learning was introduced for adaptively learning and processing the complex-valued time-varying channel [278].

Although substantial research advances have been made, there are still numerous challenges preventing physical layer authentication from practical deployment [273], some of which are listed below:

- *Low reliability.* Frequent and continuous sampling of the channel attributes is required for physical layer authentication. This may be difficult for many IoT devices, since sensor nodes may turn into sleep mode and the wireless connection is lost. The channel will have changed significantly over the dormant period and the reliability of this technique will be significantly impacted [279].
- *Integration with upper-layer authentication schemes and network infrastructure.* The principle of upper-layer authentication is quite different from its PHY counterparts. Additionally, physical layer authentication mainly operates in device-to-device mode, but wireless networks are usually large scale, with many devices not directly connected.
- *Complex heterogeneous networks.* The mobile devices will roam across the coverage area of different base stations, which requires a frequent handover. This will introduce additional complexity and latency, which may not meet the timing requirements.

B. RFF IDENTIFICATION

RFF identification authenticates the wireless devices based on their hardware imperfections resulting from the manufacturing process (see [280]–[282] and references therein). These hardware features are unique, permanent and cannot be tampered with, which are ideal for device authentication.

As shown in Fig. 28(b), RFF identification consists of two stages, namely training and classification. During the training stage, the authenticator, Bob, will collect wireless signals from a device, extracts some features and saves them in a

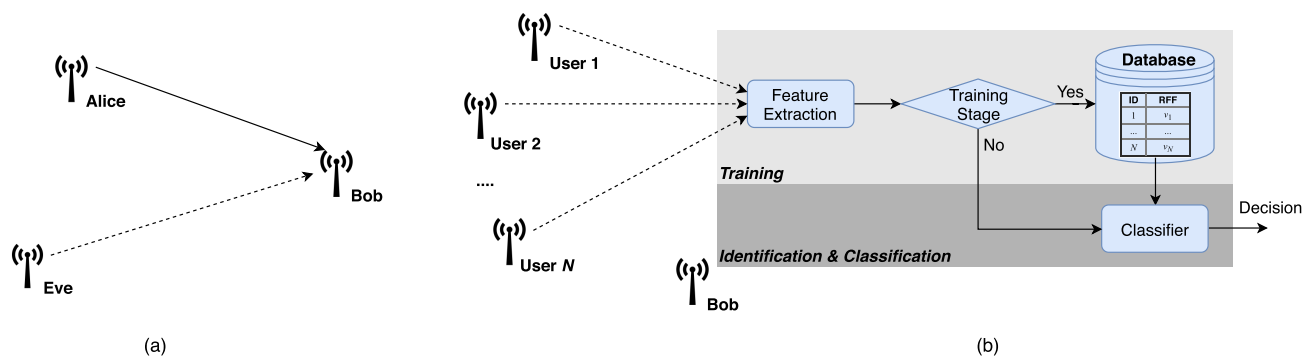

FIGURE 28. Device authentication. (a) Physical layer authentication. (b) RFF identification.

database. When the device wishes to join the network again, Bob will extract the same features from the received wireless signals, compare them against the database, and then classify the device identity.

RFF can be categorized into transient features and modulation features [280].

- Transient features represent the turn-on/off transient or signal variation, such as the envelope of the transient signals [283]. However, it is very sensitive to both the device position and to the antenna polarization.
- The modulation features are stable and extracted from the baseband signal, such as the amplifier’s non-linear characteristics [284], the carrier frequency offset [285], etc. These features can be captured by SDR platforms, such as USRP.

The classifier is designed for differentiating the devices based on the features extracted. The classification performance can be enhanced by combining multiple features [285]–[287]. Machine learning algorithms, such as support vector machine (SVM), may also be readily exploited [286]. Sometimes it is challenging to identify and extract the best feature. Hence, deep learning may be adopted to directly process the raw I/Q samples without using a particular feature [282], [288], [289].

RFF identification has been prototyped in conjunction with a number of wireless techniques, such as WiFi [285], [290], ZigBee [287], [291], Bluetooth [292] and LoRa [293]–[295], just to name a few. Because RFF identification exploits the features of wireless transceivers, it is a perfect candidate for key generation in an integrated security framework [87]. However, there are also some challenges to be tackled, when designing a reliable and robust classification system.

- *Rigorous modelling.* The transceiver hardware chain has many hardware components, such as the oscillator, mixer, power amplifier, analog-to-digital converter, filter, etc. Many of them may exhibit nonlinear characteristics. Despite some research attempts [296], a rigorous RFF modelling is challenging. On the other hand, it is desirable to gain a comprehensive understanding of the hardware effects.

- *Channel effect.* The RFF is extracted from wireless signals, which are affected by the channel fading. Since the training and classification usually do not occur at the same place, the classification performance is impaired by the different multipath fading.
- *Expensive authenticator.* RFF identification requires raw I/Q samples to extract fingerprint, which is usually not available in the COTS devices. Therefore, expensive devices such as oscilloscopes and spectrum analyzers are used in the testbed, but unfortunately, they cannot be used in operational networks. SDR platforms such as USRP are also often used, which still cost hundreds or thousands of US dollars.
- *Classification capacity.* A single gateway of IoT networks may serve thousands of end devices. Intuitively, the more devices have to be authenticated, the more complex classification algorithm and the higher requirements on the authenticator hardware specification. The capacity of the RFF identification thus requires more research [297].

IX. POTENTIAL PITFALLS AND FUTURE RESEARCH

This section first covers the ongoing debate on how attractive key generation is as a practical security solution. We then provide a number of future research directions in order to bridge the gaps.

A. IS KEY GENERATION AN ATTRACTIVE SECURITY SOLUTION?

Although there have been a number of key generation prototypes relying on various wireless techniques, a natural question arises, *is key generation really an attractive security solution?*

Trappe [279] discussed a number of challenges that physical layer security is facing before it can be adopted to protect operational communications systems. In terms of key generation, he identified the following hurdles:

- *Weak adversary model.* The key generation research community often only considers passive eavesdropping but underestimates the capabilities of active attackers.

These weak models are not recognized by the cryptographic community.

- *Idea assumption of wireless channels.* The assumption of the WSSUS and Jakes's model may not be valid in real scenarios. A sufficiently random and dynamic channel may not be available.
- *Transceiver imperfection.* Practical impairments of the transceivers will impact channel reciprocity, such as the amplifier discrepancies and transceiver burn-in and frequency drift.

Robyns *et al.* [298] discredit physical layer security, including keyless transmission, key generation and physical layer identification. In particular, the authors criticize that key generation requires an uncorrelated eavesdropping channel and the public discussion leaks information to eavesdroppers. Indeed, we concur that many of these issues have to be resolved when we consider realistic systems.

As a counter-argument, it was argued by Trappe [279] and Trappe *et al.* [299] that physical layer security/key generation will be indeed an ideal candidate to complement the classic cryptography for securing low-cost IoT devices. This is because IoT devices use the majority of their resources for supporting their core functions and there is very few of them left for security, which makes them vulnerable to attacks. On the other hand, key generation aims for exploiting existing radio resources and communications without imposing substantial additional energy consumption [299]. In addition, as demonstrated in Section VI-B1, key generation implementation costs very few computational resources. Therefore, it is deemed to be suitable for the low cost IoT devices with limited energy and computational resources.

B. VISION FOR FUTURE DIRECTIONS

Despite this promise, there are still numerous research challenges to be addressed for adopting key generation as a practical and reliable security solution. Some suggestions for future research are given below.

Key generation for 5G. 5G has adopted numerous physical layer techniques, such as massive MIMO and mmwave communications. These technologies provide more flexibility for supporting multiple users. However, the research of multi-user key generation in mmwave massive MIMO wireless communications is fairly open. Since the pilot overhead scales linearly with the number of antennas, it becomes impractical for Alice and Bob to complete their channel probing within the coherence time of massive MIMO TDD systems [86]. Furthermore, when the base station generates secret keys with multiple users in sequence, the complexity escalates with the number of users. Jiao *et al.* [300] proposed a key generation scheme for single user mmwave massive MIMO systems. Explicitly, they exploited the virtual angle of arrival (AoA) and angle of departure (AoD) characteristics of the channel to reduce both the probing time and the complexity. They imposed a small perturbation angle on the AoA as the common randomness for improving the SKR [301].

However, both the theoretical analysis of the SKR and the design of practical protocols require further investigations for multi-user key generation in mmwave massive MIMO systems.

Key generation with non-reciprocal channel. Key generation is particularly challenging in scenarios where channel reciprocity and randomness may not be readily achieved, for example in FDD systems, static environments, and vehicular communications, etc. These scenarios, however, are very common in the IoT. For example, NB-IoT is a popular IoT standard operating in FDD mode. Many IoT devices are stationary and the environment is usually static or quasi-static. Although there are some research attempts to circumvent this problem, unfortunately, the existing solutions are not general and they all need additional hardware or other resources.

Key generation in large scale fading channels. As discussed in Section II-C the communication ranges of LPWAN are on the order of km, and the channel is subject to large scale fading. Different from small scale multipath fading, large scale fading changes much slower, which limits the randomness. While there is some preliminary work on key generation for LoRa presented in Section VI-A5 and some theoretical exploration on key generation in large scale fading channels [102], it requires more investigation. It will be quite important as numerous IoT applications operate in such environments.

Key generation security analysis. As mentioned above, the attack model is weak. It is strongly recommended to enhance the security analysis and the investigation of both passive and active attacks. Since the keys generated support the cryptographic schemes, it is necessary to carry out the associated crypto-analysis, rather than pure wireless-based attack analysis.

Bridging cryptography and wireless communities. The concepts of classical cryptography and key generation are rather different, resulting in different evaluation metrics for their security levels. A common language bridging both communities is extremely desirable for unveiling the pros and cons of these techniques [299]. The hybrid cryptosystem relying on the amalgam of key generation and symmetric encryption may be deemed to be an intriguing starting point.

A final positive perspective offered by the authors of this treatise is that the Chinese Micius experiment demonstrated QKD over satellites across a distance of 1200 km [123], [302]. Hence key distillation in the classical domain is also a promising frontier research area.

X. CONCLUSION

This article provided a comprehensive survey of random key generation from wireless channels, systematically reviewing the topics of key generation fundamentals, protocol, design considerations, implementational case studies, multi-player key generation and device authentication. We first introduced the fundamentals, including random sources, principles, and followed by information-theoretic modelling and pertinent evaluation metrics. A four-stage protocol was then proposed,

including channel probing, quantization, information reconciliation and privacy amplification. We then examined the relevant design aspects, such as the channel parameter selection, the temporal, frequency and spatial signal domains, as well as duplex mode including the TDD, FDD and IBFD modes. Efforts dedicated to implementing and prototyping key generation protocols were also included. The key generation was then extended to multi-player scenarios where the third parties act as keying parties, attackers, or relays. Device authentication was briefly introduced, which can assist in identifying the keying parties in key generation. The article concluded with suggestions for future research and a list of potential pitfalls as well as scientific arguments concerning the pros and cons of this alluring frontier research subject.

ACKNOWLEDGMENT

The authors would like to thank Mr Yan Wang for his hard work implementing the key generation demonstration system during his final year project.

REFERENCES

- [1] A. Al-Fuqaha, M. Guizani, M. Mohammadi, M. Aledhari, and M. Ayyash, "Internet of Things: A survey on enabling technologies, protocols, and applications," *IEEE Commun. Surveys Tuts.*, vol. 17, no. 4, pp. 2347–2376, 4th Quart., 2015.
- [2] A. Burg, A. Chattopadhyay, and K.-Y. Lam, "Wireless communication and security issues for cyber-physical systems and the Internet-of-Things," *Proc. IEEE*, vol. 106, no. 1, pp. 38–60, Jan. 2018.
- [3] J. Manyika, M. Chui, P. Bisson, J. Woetzel, R. Dobbs, J. Bughin, and D. Aharon, *The Internet of Things: Mapping the Value Beyond the Hype*. San Francisco, CA, USA: McKinsey Global Institute, 2015.
- [4] J. Granjal, E. Monteiro, and J. Sa Silva, "Security for the Internet of Things: A survey of existing protocols and open research issues," *IEEE Commun. Surveys Tuts.*, vol. 17, no. 3, pp. 1294–1312, 3rd Quart., 2015.
- [5] A. Mukherjee, "Physical-layer security in the Internet of Things: Sensing and communication confidentiality under resource constraints," *Proc. IEEE*, vol. 103, no. 10, pp. 1747–1761, Oct. 2015.
- [6] Y. Zou, J. Zhu, X. Wang, and L. Hanzo, "A survey on wireless security: Technical challenges, recent advances, and future trends," *Proc. IEEE*, vol. 104, no. 9, pp. 1727–1765, Sep. 2016.
- [7] A. Grau. (Feb. 2015). *How to Build a Safer Internet of Things*. Accessed: Apr. 21, 2020. [Online]. Available: <http://spectrum.ieee.org/telecom/security/how-to-build-a-safer-internet-of-things>
- [8] E. Marin, D. Singelée, F. D. Garcia, T. Chothia, R. Willems, and B. Preneel, "On the (in) security of the latest generation implantable cardiac defibrillators and how to secure them," in *Proc. 32nd Annu. Conf. Comput. Secur. Appl.*, Los Angeles, CA, USA, Dec. 2016, pp. 226–236.
- [9] F. D. Garcia, D. Oswald, T. Kasper, and P. Pavlidès, "Lock it and still lose it—On the (in)security of automotive remote keyless entry systems," in *Proc. 25th USENIX Secur. Symp.*, Austin, TX, USA, Aug. 2016, pp. 929–944.
- [10] M. Vanhoef and F. Piessens, "Key reinstallation attacks: Forcing nonce reuse in WPA2," in *Proc. ACM SIGSAC Conf. Comput. Commun. Secur.*, Dallas, USA, Oct/Nov. 2017, pp. 1313–1328.
- [11] G. S. Vernam, "Secret signaling system," U.S. Patent 1310719, Jul. 12, 1919.
- [12] C. E. Shannon, "Communication theory of secrecy Systems," *Bell Syst. Tech. J.*, vol. 28, no. 4, pp. 656–715, Oct. 1949.
- [13] A. D. Wyner, "The wire-tap channel," *Bell Syst. Tech. J.*, vol. 54, no. 8, pp. 1355–1387, Oct. 1975.
- [14] S. Leung-Yan-Cheong and M. Hellman, "The Gaussian wire-tap channel," *IEEE Trans. Inf. Theory*, vol. IT-24, no. 4, pp. 451–456, Jul. 1978.
- [15] A. Mukherjee, S. A. A. Fakoorian, J. Huang, and A. L. Swindlehurst, "Principles of physical layer security in multiuser wireless networks: A survey," *IEEE Commun. Surveys Tuts.*, vol. 16, no. 3, pp. 1550–1573, 3rd Quart., 2014.
- [16] M. Bloch, J. Barros, M. R. D. Rodrigues, and S. W. McLaughlin, "Wireless information-theoretic security," *IEEE Trans. Inf. Theory*, vol. 54, no. 6, pp. 2515–2534, Jun. 2008.
- [17] Y. Liu, H.-H. Chen, and L. Wang, "Physical layer security for next generation wireless networks: Theories, technologies, and challenges," *IEEE Commun. Surveys Tuts.*, vol. 19, no. 1, pp. 347–376, 1st Quart., 2017.
- [18] H. V. Poor and R. F. Schaefer, "Wireless physical layer security," *Proc. Nat. Acad. Sci. USA*, vol. 114, no. 1, pp. 19–26, Jan. 2017.
- [19] Y. Wu, A. Khisti, C. Xiao, G. Caire, K.-K. Wong, and X. Gao, "A survey of physical layer security techniques for 5G wireless networks and challenges ahead," *IEEE J. Sel. Areas Commun.*, vol. 36, no. 4, pp. 679–695, Apr. 2018.
- [20] J. M. Hamamreh, H. M. Furqan, and H. Arslan, "Classifications and applications of physical layer security techniques for confidentiality: A comprehensive survey," *IEEE Commun. Surveys Tuts.*, vol. 21, no. 2, pp. 1773–1828, 2nd Quart., 2019.
- [21] S. Goel and R. Negi, "Guaranteeing secrecy using artificial noise," *IEEE Trans. Wireless Commun.*, vol. 7, no. 6, pp. 2180–2189, Jun. 2008.
- [22] X. Ding, T. Song, Y. Zou, X. Chen, and L. Hanzo, "Security-reliability tradeoff analysis of artificial noise aided two-way opportunistic relay selection," *IEEE Trans. Veh. Technol.*, vol. 66, no. 5, pp. 3930–3941, May 2017.
- [23] F. Zhou, Z. Chu, H. Sun, R. Q. Hu, and L. Hanzo, "Artificial noise aided secure cognitive beamforming for cooperative MISO-NOMA using SWIPT," *IEEE J. Sel. Areas Commun.*, vol. 36, no. 4, pp. 918–931, Apr. 2018.
- [24] Y. Wen, M. Yoshida, J. Zhang, Z. Chu, P. Xiao, and R. Tafazolli, "Machine learning based attack against artificial noise-aided secure communication," in *Proc. IEEE Int. Conf. Commun. (ICC)*, Shanghai, China, May 2019, pp. 1–6.
- [25] A. Mukherjee and A. L. Swindlehurst, "Robust beamforming for security in MIMO wiretap channels with imperfect CSI," *IEEE Trans. Signal Process.*, vol. 59, no. 1, pp. 351–361, Jan. 2011.
- [26] Y. Zhang, Y. Ko, R. Woods, and A. Marshall, "Defining spatial secrecy outage probability for exposure region-based beamforming," *IEEE Trans. Wireless Commun.*, vol. 16, no. 2, pp. 900–912, Feb. 2017.
- [27] Y. Zhang, R. Woods, Y. Ko, A. Marshall, and J. Zhang, "Security optimization of exposure region-based beamforming with a uniform circular array," *IEEE Trans. Commun.*, vol. 66, no. 6, pp. 2630–2641, Jun. 2018.
- [28] Z. Kong, S. Yang, D. Wang, and L. Hanzo, "Robust beamforming and jamming for enhancing the physical layer security of full duplex radios," *IEEE Trans. Inf. Forensics Security*, vol. 14, no. 12, pp. 3151–3159, Dec. 2019.
- [29] B. He and X. Zhou, "Secure on-off transmission design with channel estimation errors," *IEEE Trans. Inf. Forensics Security*, vol. 8, no. 12, pp. 1923–1936, Dec. 2013.
- [30] W. Diffie and M. Hellman, "New directions in cryptography," *IEEE Trans. Inf. Theory*, vol. IT-22, no. 6, pp. 644–654, Nov. 1976.
- [31] W. Stallings, *Cryptography and Network Security: Principles and Practice*, 5th ed. Upper Saddle River, NJ, USA: Pearson, 2017.
- [32] *Data Encryption Standard (DES)*, Federal Information Processing Standards Publication Standard FIPS PUB 46-3, 1999. Accessed: Apr. 21, 2020. [Online]. Available: <http://gocs.info/pages/chiffrierverfahren/archiv/1-fips46-3.pdf>
- [33] *Advanced Encryption Standard*, Federal Information Processing Standards Publication Standard FIPS PUB 197, 2001. Accessed: Apr. 21, 2020. [Online]. Available: <http://csrc.nist.gov/publications/fips/fips197/fips-197.pdf>
- [34] *Wireless LAN Medium Access Control (MAC) and Physical Layer (PHY) Specification*, IEEE Standard 802.11, 2012.
- [35] *IEEE Standard for Low-Rate Wireless Networks*, IEEE Standard 802.15.4, 2015.
- [36] *Bluetooth Core Specification*, Bluetooth SIG Proprietary Standard 5.1, 2019. Accessed: Apr. 21, 2020. [Online]. Available: <https://www.bluetooth.com/specifications/bluetooth-core-specification/>
- [37] *LoRaWAN 1.1 Specification*, LoRa Alliance, Fremont, CA, USA, 2017.
- [38] J.-P.-E. Wang, X. Lin, A. Adhikary, A. Grovlen, Y. Sui, Y. Blankenship, Y. Bergman, and H. S. Razaghi, "A primer on 3GPP narrowband Internet of Things," *IEEE Commun. Mag.*, vol. 55, no. 3, pp. 117–123, Mar. 2017.
- [39] *Sigfox*. Accessed: Apr. 21, 2020. [Online]. Available: <https://www.sigfox.com/en/what-sigfox/technology>
- [40] K.-A. Shim, "A survey of public-key cryptographic primitives in wireless sensor networks," *IEEE Commun. Surveys Tuts.*, vol. 18, no. 1, pp. 577–601, 1st Quart., 2016.

- [41] A. Liu and P. Ning, "TinyECC: A configurable library for elliptic curve cryptography in wireless sensor networks," in *Proc. 7th Int. Conf. Inf. Process. Sensor Netw.*, St. Louis, MI, USA, Apr. 2008, pp. 245–256.
- [42] P. Szczechowiak, L. B. Oliveira, M. Scott, M. Collier, and R. Dahab, "NanoECC: Testing the limits of elliptic curve cryptography in sensor networks," in *Proc. Eur. Conf. Wireless Sensor Netw.*, vol. 2008, pp. 305–320.
- [43] C. Cheng, R. Lu, A. Peltzoldt, and T. Takagi, "Securing the Internet of Things in a quantum world," *IEEE Commun. Mag.*, vol. 55, no. 2, pp. 116–120, Feb. 2017.
- [44] M. Antonakakis, T. April, M. Bailey, M. Bernhard, E. Bursztein, J. Cochran, Z. Durumeric, J. A. Halderman, L. Invernizzi, M. Kallitsis, D. Kumar, C. Lever, Z. Ma, J. Mason, D. Menscher, C. Seaman, N. Sullivan, K. Thomas, and Y. Zhou, "Understanding the Mirai Botnet," in *Proc. 26th USENIX Secur. Symp.*, 2017, pp. 1093–1110.
- [45] (2018). *New IoT-Malware Grew Three-Fold in H1*. Accessed: Apr. 21, 2020. [Online]. Available: https://www.kaspersky.com/about/press-releases/2018_new-iot-malware-gre%w-three-fold-in-h1-2018
- [46] E. Ronen, A. Shamir, A.-O. Weingarten, and C. O'Flynn, "IoT goes nuclear: Creating a ZigBee chain reaction," in *Proc. IEEE Symp. Secur. Privacy*, San Jose, CA, USA, May 2017, pp. 195–212.
- [47] M. Bloch and J. Barros, *Physical-Layer Security: From Information Theory to Security Engineering*. Cambridge, U.K.: Cambridge Univ. Press, 2011.
- [48] L. Lai, Y. Liang, and H. V. Poor, "A unified framework for key agreement over wireless fading channels," *IEEE Trans. Inf. Forensics Security*, vol. 7, no. 2, pp. 480–490, Apr. 2012.
- [49] S. Tomasin and A. Dall'Arche, "Resource allocation for secret key agreement over parallel channels with full and partial eavesdropper CSI," *IEEE Trans. Inf. Forensics Security*, vol. 10, no. 11, pp. 2314–2324, Nov. 2015.
- [50] Z. Rezki, M. Zorghi, B. Alomair, and M.-S. Alouini, "Secret key agreement: Fundamental limits and practical challenges," *IEEE Wireless Commun.*, vol. 24, no. 3, pp. 72–79, Jun. 2017.
- [51] R. Ahlswede and I. Csiszar, "Common randomness in information theory and cryptography. I. Secret sharing," *IEEE Trans. Inf. Theory*, vol. 39, no. 4, pp. 1121–1132, Jul. 1993.
- [52] U. M. Maurer, "Secret key agreement by public discussion from common information," *IEEE Trans. Inf. Theory*, vol. 39, no. 3, pp. 733–742, May 1993.
- [53] J. E. Hershey, A. A. Hassan, and R. Yarlagadda, "Unconventional cryptographic keying variable management," *IEEE Trans. Commun.*, vol. 43, no. 1, pp. 3–6, Jan. 1995.
- [54] A. A. Hassan, W. E. Stark, J. E. Hershey, and S. Chennakeshu, "Cryptographic key agreement for mobile radio," *Digit. Signal Process.*, vol. 6, no. 4, pp. 207–212, Oct. 1996.
- [55] U. M. Maurer and S. Wolf, "Unconditionally secure key agreement and the intrinsic conditional information," *IEEE Trans. Inf. Theory*, vol. 45, no. 2, pp. 499–514, Mar. 1999.
- [56] U. Maurer and S. Wolf, "Secret-key agreement over unauthenticated public channels—Part I: Definitions and a completeness result," *IEEE Trans. Inf. Theory*, vol. 49, no. 4, pp. 822–831, Apr. 2003.
- [57] C. Ye, A. Reznik, and Y. Shah, "Extracting secrecy from jointly Gaussian random variables," in *Proc. IEEE Int. Symp. Inf. Theory*, Seattle, WA, USA, Jul. 2006, pp. 2593–2597.
- [58] J. W. Wal and R. K. Sharma, "Automatic secret keys from reciprocal MIMO wireless channels: Measurement and analysis," *IEEE Trans. Inf. Forensics Security*, vol. 5, no. 3, pp. 381–392, Sep. 2010.
- [59] Y. Liu, S. C. Draper, and A. M. Sayeed, "Exploiting channel diversity in secret key generation from multipath fading randomness," *IEEE Trans. Inf. Forensics Security*, vol. 7, no. 5, pp. 1484–1497, Oct. 2012.
- [60] J. Zhang, A. Marshall, R. Woods, and T. Q. Duong, "Efficient key generation by exploiting randomness from channel responses of individual OFDM subcarriers," *IEEE Trans. Commun.*, vol. 64, no. 6, pp. 2578–2588, Jun. 2016.
- [61] J. Zhang, B. He, T. Q. Duong, and R. Woods, "On the key generation from correlated wireless channels," *IEEE Commun. Lett.*, vol. 21, no. 4, pp. 961–964, Apr. 2017.
- [62] N. Patwari, J. Croft, S. Jana, and S. K. Kaspera, "High-rate uncorrelated bit extraction for shared secret key generation from channel measurements," *IEEE Trans. Mobile Comput.*, vol. 9, no. 1, pp. 17–30, Jan. 2010.
- [63] Y. Wei, K. Zeng, and P. Mohapatra, "Adaptive wireless channel probing for shared key generation based on PID controller," *IEEE Trans. Mobile Comput.*, vol. 12, no. 9, pp. 1842–1852, Sep. 2013.
- [64] C. T. Zenger, M. Pietersz, J. Zimmer, J.-F. Posielek, T. Lenze, and C. Paar, "Authenticated key establishment for low-resource devices exploiting correlated random channels," *Comput. Netw.*, vol. 109, pp. 105–123, Nov. 2016.
- [65] G. Li, A. Hu, J. Zhang, L. Peng, C. Sun, and D. Cao, "High-agreement uncorrelated secret key generation based on principal component analysis preprocessing," *IEEE Trans. Commun.*, vol. 66, no. 7, pp. 3022–3034, Jul. 2018.
- [66] T. Aono, K. Higuchi, T. Ohira, B. Komiyama, and H. Sasaoka, "Wireless secret key generation exploiting reactance-domain scalar response of multipath fading channels," *IEEE Trans. Antennas Propag.*, vol. 53, no. 11, pp. 3776–3784, Nov. 2005.
- [67] M. Wilhelm, I. Martinovic, and J. B. Schmitt, "Secure key generation in sensor networks based on frequency-selective channels," *IEEE J. Sel. Areas Commun.*, vol. 31, no. 9, pp. 1779–1790, Sep. 2013.
- [68] S. T. Ali, V. Sivaraman, and D. Ostry, "Eliminating reconciliation cost in secret key generation for body-worn health monitoring devices," *IEEE Trans. Mobile Comput.*, vol. 13, no. 12, pp. 2763–2776, Dec. 2014.
- [69] S. Mathur, W. Trappe, N. Mandayam, C. Ye, and A. Reznik, "Radio-telepathy: Extracting a secret key from an unauthenticated wireless channel," in *Proc. 14th Annu. Int. Conf. Mobile Comput. Netw. (MobiCom)*, San Francisco, CA, USA, Sep. 2008, pp. 128–139.
- [70] S. Jana, S. N. Premnath, M. Clark, S. K. Kaspera, N. Patwari, and S. V. Krishnamurthy, "On the effectiveness of secret key extraction from wireless signal strength in real environments," in *Proc. 15th Annu. Int. Conf. Mobile Comput. Netw. (MobiCom)*, Beijing, China, Sep. 2009, pp. 321–332.
- [71] C. Ye, S. Mathur, A. Reznik, Y. Shah, W. Trappe, and N. B. Mandayam, "Information-theoretically secret key generation for fading wireless channels," *IEEE Trans. Inf. Forensics Security*, vol. 5, no. 2, pp. 240–254, Jun. 2010.
- [72] K. Zeng, D. Wu, A. Chan, and P. Mohapatra, "Exploiting multiple-antenna diversity for shared secret key generation in wireless networks," in *Proc. 29th IEEE Int. Conf. Comput. Commun. (INFOCOM)*, San Diego, CA, USA, Mar. 2010, pp. 1–9.
- [73] H. Liu, Y. Wang, J. Yang, and Y. Chen, "Fast and practical secret key extraction by exploiting channel response," in *Proc. 32nd IEEE Int. Conf. Comput. Commun. (INFOCOM)*, Turin, Italy, Apr. 2013, pp. 3048–3056.
- [74] J. Zhang, R. Woods, T. Q. Duong, A. Marshall, Y. Ding, Y. Huang, and Q. Xu, "Experimental study on key generation for physical layer security in wireless communications," *IEEE Access*, vol. 4, pp. 4464–4477, Aug. 2016.
- [75] J. Zhang, M. Ding, D. López-Pérez, A. Marshall, and L. Hanzo, "Design of an efficient OFDMA-based multi-user key generation protocol," *IEEE Trans. Veh. Technol.*, vol. 68, no. 9, pp. 8842–8852, Sep. 2019.
- [76] S. N. Premnath, P. L. Gowda, S. K. Kaspera, N. Patwari, and R. Ricci, "Secret key extraction using Bluetooth wireless signal strength measurements," in *Proc. 11th Annu. IEEE Int. Conf. Sens., Commun., Netw. (SECON)*, Singapore, Jun. 2014, pp. 293–301.
- [77] J. Zhang, A. Marshall, and L. Hanzo, "Channel-envelope differencing eliminates secret key correlation: LoRa-based key generation in low power wide area networks," *IEEE Trans. Veh. Technol.*, vol. 67, no. 12, pp. 12462–12466, Dec. 2018.
- [78] W. Xu, S. Jha, and W. Hu, "LoRa-key: Secure key generation system for LoRa-based network," *IEEE Internet Things J.*, vol. 6, no. 4, pp. 6404–6416, Aug. 2019.
- [79] H. Ruotsalainen, J. Zhang, and S. Grebeniuk, "Experimental investigation on wireless key generation for low-power wide-area networks," *IEEE Internet Things J.*, vol. 7, no. 3, pp. 1745–1755, Mar. 2020.
- [80] G. Li, Z. Zhang, J. Zhang, and A. Hu, "Encrypting wireless communications on the fly using one-time pad and key generation," *IEEE Internet Things J.*, early access, Jun. 23, 2020, doi: 10.1109/JIOT.2020.3004451.
- [81] K. Ren, H. Su, and Q. Wang, "Secret key generation exploiting channel characteristics in wireless communications," *IEEE Wireless Commun.*, vol. 18, no. 4, pp. 6–12, Aug. 2011.
- [82] K. Zeng, "Physical layer key generation in wireless networks: Challenges and opportunities," *IEEE Commun. Mag.*, vol. 53, no. 6, pp. 33–39, Jun. 2015.
- [83] T. Wang, Y. Liu, and A. V. Vasilakos, "Survey on channel reciprocity based key establishment techniques for wireless systems," *Wireless Netw.*, vol. 21, pp. 1835–1846, Jan. 2015.
- [84] J. Zhang, T. Q. Duong, A. Marshall, and R. Woods, "Key generation from wireless channels: A review," *IEEE Access*, vol. 4, pp. 614–626, Mar. 2016.

- [85] J. Zhang, T. Duong, R. Woods, and A. Marshall, "Securing wireless communications of the Internet of Things from the physical layer, an overview," *Entropy*, vol. 19, no. 8, p. 420, Aug. 2017.
- [86] G. Li, C. Sun, J. Zhang, E. Jorswieck, B. Xiao, and A. Hu, "Physical layer key generation in 5G and beyond wireless communications: Challenges and opportunities," *Entropy*, vol. 21, no. 5, p. 497, May 2019.
- [87] J. Zhang, S. Rajendran, Z. Sun, R. Woods, and L. Hanzo, "Physical layer security for the Internet of Things: Authentication and key generation," *IEEE Wireless Commun.*, vol. 26, no. 5, pp. 92–98, Oct. 2019.
- [88] C. Gomez, J. Oller, and J. Paradells, "Overview and evaluation of Bluetooth low energy: An emerging low-power wireless technology," *Sensors*, vol. 12, no. 9, pp. 11734–11753, 2012.
- [89] V. Niemelä, J. Haapola, M. Hämäläinen, and J. Iinatti, "An ultra wide-band survey: Global regulations and impulse radio research based on standards," *IEEE Commun. Surveys Tuts.*, vol. 19, no. 2, pp. 874–890, 2nd Quart., 2017.
- [90] Y. Li, H. Minn, T. Jacobs, and M. Win, "Frequency offset estimation for MB-OFDM-based UWB systems," *IEEE Trans. Commun.*, vol. 56, no. 6, pp. 968–979, Jun. 2008.
- [91] L.-L. Yang and L. Hanzo, "Residue number system assisted fast frequency-hopped synchronous ultra-wideband spread-spectrum multiple-access: A design alternative to impulse radio," *IEEE J. Sel. Areas Commun.*, vol. 20, no. 9, pp. 1652–1663, Dec. 2002.
- [92] U. Raza, P. Kulkarni, and M. Sooriyabandara, "Low power wide area networks: An overview," *IEEE Commun. Surveys Tuts.*, vol. 19, no. 2, pp. 855–873, 2nd Quart., 2017.
- [93] *LoRaWAN 1.1 Regional Parameters*. Accessed: Apr. 21, 2020. [Online]. Available: <https://loro-alliance.org/resource-hub/lorawanm-regional-parameters-v1%1rb>
- [94] A. H. Sodhro, J. J. P. C. Rodrigues, S. Pirbhulal, N. Zahid, A. Roberto L. de Macedo, and V. H. C. de Albuquerque, "Link optimization in software defined IoT driven autonomous transportation system," *IEEE Trans. Intell. Transp. Syst.*, early access, Feb. 26, 2020, doi: [10.1109/TITS.2020.2973878](https://doi.org/10.1109/TITS.2020.2973878).
- [95] S. Pirbhulal, W. Wu, K. Muhammad, I. Mehmood, G. Li, and V. H. C. de Albuquerque, "Mobility enabled security for optimizing IoT based intelligent applications," *IEEE Netw.*, vol. 34, no. 2, pp. 72–77, Mar. 2020.
- [96] S. Pirbhulal, H. Zhang, M. El Alahi, H. Ghayvat, S. Mukhopadhyay, Y.-T. Zhang, and W. Wu, "A novel secure IoT-based smart home automation system using a wireless sensor network," *Sensors*, vol. 17, no. 12, p. 69, Dec. 2016.
- [97] M. Almulhim and N. Zaman, "Proposing secure and lightweight authentication scheme for IoT based E-health applications," in *Proc. 20th Int. Conf. Adv. Commun. Technol.*, Chuncheon-si Gangwon-do, South Korea, Feb. 2018, pp. 481–487.
- [98] M. Almulhim, N. Islam, and N. Zaman, "A lightweight and secure authentication scheme for IoT based e-health applications," *Int. J. Comput. Sci. Netw. Secur.*, vol. 19, no. 1, pp. 107–120, 2019.
- [99] S. Pirbhulal, W. Wu, G. Li, and A. K. Sangaiah, "Medical information security for wearable body sensor networks in smart healthcare," *IEEE Consum. Electron. Mag.*, vol. 8, no. 5, pp. 37–41, Sep. 2019.
- [100] *CC253x System-on-Chip Solution for 2.4-GHz IEEE 802.15.4, and Zig-Bee Applications*, IEEE Standard 802.15.4, 2014.
- [101] A. Goldsmith, *Wireless Communications*. Cambridge, U.K.: Cambridge Univ. Press, 2005.
- [102] J. Zhang, M. Ding, G. Li, and A. Marshall, "Key generation based on large scale fading," *IEEE Trans. Veh. Technol.*, vol. 68, no. 8, pp. 8222–8226, Aug. 2019.
- [103] W. C. Jakes and D. C. Cox, *Microwave Mobile Communications*. Hoboken, NJ, USA: Wiley, 1994.
- [104] O. A. Topal, G. K. Kurt, and B. Özbek, "Key error rates in physical layer key generation: Theoretical analysis and measurement-based verification," *IEEE Wireless Commun. Lett.*, vol. 6, no. 6, pp. 766–769, Dec. 2017.
- [105] A. Albehadili, K. Al Shamaileh, A. Javaid, J. Oluoch, and V. Devabhaktuni, "An upper bound on phy-layer key generation for secure communications over a Nakagami-m fading channel with asymmetric additive noise," *IEEE Access*, vol. 6, pp. 28137–28149, 2018.
- [106] A. Rukhin, J. Soto, J. Nechvatal, M. Smid, E. Barker, S. Leigh, M. Levenson, M. Vangel, D. Banks, A. Heckert, J. Dray, and S. Vo, "A statistical test suite for random and pseudorandom number generators for cryptographic applications," Nat. Inst. Standards Technol., Gaithersburg, MD, USA, Tech. Rep. Special Publication 800-22 Revision 1a, Apr. 2010.
- [107] National Institute of Standards and Technology. *NIST SP 800-22: Download Documentation and Software*. Accessed: Apr. 21, 2020. [Online]. Available: <https://csrc.nist.gov/projects/random-bit-generation/documentation-and-%software>
- [108] K. A. Steven. Randomness Test suite. GitHub Repository. Accessed: Apr. 21, 2020. [Online]. Available: https://github.com/stevenang/randomness_testsuite
- [109] Y. Peng, P. Wang, W. Xiang, and Y. Li, "Secret key generation based on estimated channel state information for TDD-OFDM systems over fading channels," *IEEE Trans. Wireless Commun.*, vol. 16, no. 8, pp. 5176–5186, Aug. 2017.
- [110] C. Chen and M. A. Jensen, "Secret key establishment using temporally and spatially correlated wireless channel coefficients," *IEEE Trans. Mobile Comput.*, vol. 10, no. 2, pp. 205–215, Feb. 2011.
- [111] X. Jiang, M. Čirkčić, F. Kaltenberger, E. G. Larsson, L. Deneire, and R. Knopp, "MIMO-TDD reciprocity under hardware imbalances: Experimental results," in *Proc. IEEE Int. Conf. Commun. (ICC)*, London, U.K., Jun. 2015, pp. 4949–4953.
- [112] G. Li, A. Hu, Y. Zou, L. Peng, and M. Valkama, "A novel transform for secret key generation in time-varying TDD channel under hardware fingerprint deviation," in *Proc. IEEE 82nd Veh. Technol. Conf. (VTC-Fall)*, Boston, MA, USA, Sep. 2015, pp. 1–5.
- [113] S. Yasukawa, H. Iwai, and H. Sasaoka, "Adaptive key generation in secret key agreement scheme based on the channel characteristics in OFDM," in *Proc. Int. Symp. Inf. Theory Appl.*, Auckland, New Zealand, Dec. 2008, pp. 1–6.
- [114] G. Margelis, X. Fafoutis, G. Oikonomou, R. Piechocki, T. Tryfonas, and P. Thomas, "Physical layer secret-key generation with discreet cosine transform for the Internet of Things," in *Proc. IEEE Int. Conf. Commun. (ICC)*, Paris, France, May 2017.
- [115] Y. Wu, Y. Sun, L. Zhan, and Y. Ji, "Low mismatch key agreement based on wavelet-transform trend and fuzzy vault in body area network," *Int. J. Distrib. Sensor Netw.*, vol. 2013, no. 2, pp. 1–16, 2013.
- [116] F. Zhan and N. Yao, "On the using of discrete wavelet transform for physical layer key generation," *Ad Hoc Netw.*, vol. 64, pp. 22–32, Sep. 2017.
- [117] S. Gopinath, R. Guillaume, P. Duplys, and A. Czylwik, "Reciprocity enhancement and decorrelation schemes for phy-based key generation," in *Proc. IEEE GLOBECOM Workshop Trusted Commun. Phys. Layer Secur. (TCPLS)*, Austin, TX, USA, Dec. 2014, pp. 1367–1372.
- [118] B. Zan, M. Gruteser, and F. Hu, "Key agreement algorithms for vehicular communication networks based on reciprocity and diversity theorems," *IEEE Trans. Veh. Technol.*, vol. 62, no. 8, pp. 4020–4027, Oct. 2013.
- [119] R. Guillaume, A. Mueller, C. T. Zenger, C. Paar, and A. Czylwik, "Fair comparison and evaluation of quantization schemes for PHY-based key generation," in *Proc. 18th Int. OFDM Workshop (InOWo)*, Essen, Germany, Aug. 2014, pp. 1–5.
- [120] C. T. Zenger, J. Zimmer, and C. Paar, "Security analysis of quantization schemes for channel-based key extraction," in *Proc. Workshop Wireless Commun. Secur. Phys. Layer*, Coimbra, Portugal, Jul. 2015, pp. 1–6.
- [121] Q. Han, J. Liu, Z. Shen, J. Liu, and F. Gong, "Vector partitioning quantization utilizing k-means clustering for physical layer secret key generation," *Inf. Sci.*, vol. 512, pp. 137–160, Feb. 2020.
- [122] C. Huth, R. Guillaume, T. Strohm, P. Duplys, I. A. Samuel, and T. Güneysu, "Information reconciliation schemes in physical-layer security: A survey," *Comput. Netw.*, vol. 109, pp. 84–104, Nov. 2016.
- [123] N. Hosseini-dehaj, Z. Babar, R. Malaney, S. X. Ng, and L. Hanzo, "Satellite-based continuous-variable quantum communications: State-of-the-art and a predictive outlook," *IEEE Commun. Surveys Tuts.*, vol. 21, no. 1, pp. 881–919, 1st Quart., 2019.
- [124] C. H. Bennett, F. Bessette, G. Brassard, L. Salvail, and J. Smolin, "Experimental quantum cryptography," *J. Cryptol.*, vol. 5, no. 1, pp. 3–28, Jan. 1992.
- [125] G. Brassard and L. Salvail, "Secret-key reconciliation by public discussion," in *Proc. Adv. Cryptol.-Eurocrypt*, vol. 765, 1993, pp. 410–423.
- [126] W. T. Buttler, S. K. Lamoreaux, J. R. Torgerson, G. H. Nickel, C. H. Donahue, and C. G. Peterson, "Fast, efficient error reconciliation for quantum cryptography," *Phys. Rev. A, Gen. Phys.*, vol. 67, no. 5, pp. 125–128, May 2003.

- [127] M. Toyran, "More efficient implementations of cascade information reconciliation protocol," in *Proc. 24th Signal Process. Commun. Appl. Conf. (SIU)*, 2016, pp. 161–164.
- [128] Z. Feng and L. Jingling, "Performance of an improved one-way error reconciliation protocol based on key redistribution," *China Commun.*, vol. 11, no. 6, pp. 63–70, Jun. 2014.
- [129] Y. Dodis, R. Ostrovsky, L. Reyzin, and A. Smith, "Fuzzy extractors: How to generate strong keys from biometrics and other noisy data," *SIAM J. Comput.*, vol. 38, no. 1, pp. 97–139, Jan. 2008.
- [130] P. Treeviriyapab, P. Sangwongngam, K. Sripimanwat, and O. Sangaroon, "BCH-based Slepian-Wolf coding with feedback syndrome decoding for quantum key reconciliation," in *Proc. Int. Conf. Electr. Eng./Electron.*, Phetchaburi, Thailand, May 2012, pp. 1–4.
- [131] D. Chen, Z. Qin, X. Mao, P. Yang, Z. Qin, and R. Wang, "SmokeGrenade: An efficient key generation protocol with artificial interference," *IEEE Trans. Inf. Forensics Security*, vol. 8, no. 11, pp. 1731–1745, Nov. 2013.
- [132] J. Zhang, S. K. Kasera, and N. Patwari, "Mobility assisted secret key generation using wireless link signatures," in *Proc. 32nd IEEE Int. Conf. Comput. Commun. (INFOCOM)*, San Diego, CA, USA, Mar. 2010, pp. 1–5.
- [133] S. Mathur, R. Miller, A. Varshavsky, W. Trappe, and N. Mandayam, "Proximate: Proximity-based secure pairing using ambient wireless signals," in *Proc. 9th Int. Conf. Mobile Syst., Appl., Services (MobiSys)*, Washington, DC, USA, Jul. 2011, pp. 211–224.
- [134] H. Liu, J. Yang, Y. Wang, and Y. Chen, "Collaborative secret key extraction leveraging received signal strength in mobile wireless networks," in *Proc. 31st IEEE Int. Conf. Comput. Commun. (INFOCOM)*, Orlando, FL, USA, Mar. 2012, pp. 927–935.
- [135] H. Liu, J. Yang, Y. Wang, Y. Chen, and C. E. Koksal, "Group secret key generation via received signal strength: Protocols, achievable rates, and implementation," *IEEE Trans. Mobile Comput.*, vol. 13, no. 12, pp. 2820–2835, Dec. 2014.
- [136] G. Epihianou, P. Karadimas, D. K. B. Ismail, H. Al-Khateeb, A. Deghantanha, and K.-K.-R. Choo, "Nonreciprocity compensation combined with turbo codes for secret key generation in vehicular ad hoc social IoT networks," *IEEE Internet Things J.*, vol. 5, no. 4, pp. 2496–2505, Aug. 2018.
- [137] S. Zhang, L. Jin, S. Zhu, K. Huang, and Z. Zhong, "Information reconciliation based on systematic secure polar code for secret key generation," in *Proc. IEEE 88th Veh. Technol. Conf. (VTC-Fall)*, Aug. 2018, pp. 1–6.
- [138] T. Tian and C. R. Jones, "Construction of rate-compatible LDPC codes utilizing information shortening and parity puncturing," *EURASIP J. Wireless Commun. Netw.*, vol. 2005, no. 5, pp. 789–795, Dec. 2005.
- [139] D. Elkouss, J. Martinez, D. Lancho, and V. Martin, "Rate compatible protocol for information reconciliation: An application to QKD," in *Proc. IEEE Inf. Theory Workshop*, Jan. 2010, pp. 1–5.
- [140] G. Li, Z. Zhang, Y. Yu, and A. Hu, "A hybrid information reconciliation method for physical layer key generation," *Entropy*, vol. 21, no. 7, p. 688, Jul. 2019.
- [141] L. Peng, G. Li, J. Zhang, and A. Hu, "Securing M2M transmissions using nonreconciled secret keys generated from wireless channels," in *Proc. IEEE Globecom Workshops*, Abu Dhabi, United Arab Emirates, Dec. 2018, pp. 1–6.
- [142] G. Li, L. Hu, and A. Hu, "Lightweight group secret key generation leveraging non-reconciled received signal strength in mobile wireless networks," in *Proc. IEEE Int. Conf. Commun. Workshops*, Shanghai, China, May 2019, pp. 1–6.
- [143] C. Cachin and U. M. Maurer, "Linking information reconciliation and privacy amplification," *J. Cryptol.*, vol. 10, no. 2, pp. 97–110, Mar. 1997.
- [144] S. N. Premnath, S. Jana, J. Croft, P. L. Gowda, M. Clark, S. K. Kasera, N. Patwari, and S. V. Krishnamurthy, "Secret key extraction from wireless signal strength in real environments," *IEEE Trans. Mobile Comput.*, vol. 12, no. 5, pp. 917–930, May 2013.
- [145] A. Ambekar, M. Hassan, and H. D. Schotten, "Improving channel reciprocity for effective key management systems," in *Proc. Int. Symp. Signals, Syst., Electron. (ISSSE)*, Potsdam, Germany, Oct. 2012, pp. 1–4.
- [146] R. Impagliazzo, L. A. Levin, and M. Luby, "Pseudo-random generation from one-way functions," in *Proc. 21st Annu. ACM Symp. Theory Comput.*, Seattle, WA, USA, May 1989, pp. 12–24.
- [147] Z. Dvir, S. Kopparty, S. Saraf, and M. Sudan, "Extensions to the method of multiplicities, with applications to kakeya sets and mergers," *SIAM J. Comput.*, vol. 42, no. 6, pp. 2305–2328, Jan. 2013.
- [148] V. Guruswami, C. Umans, and S. Vadhan, "Unbalanced expanders and randomness extractors from Parvaresh–Vardy codes," *J. ACM*, vol. 56, no. 4, p. 20, 2009.
- [149] C.-J. Lu, O. Reingold, S. Vadhan, and A. Wigderson, "Extractors: Optimal up to constant factors," in *Proc. 35th Annu. ACM Symp. Theory Comput.*, 2003, pp. 602–611.
- [150] C.-M. Zhang, M. Li, J.-Z. Huang, H.-W. Li, F.-Y. Li, C. Wang, Z.-Q. Yin, W. Chen, Z.-F. Han, P. Treeviriyapab, and K. Sripimanwat, "Fast implementation of length-adaptive privacy amplification in quantum key distribution," *Chin. Phys. B*, vol. 23, no. 9, Sep. 2014, Art. no. 090310.
- [151] R. Takahashi, Y. Tanizawa, and A. R. Dixon, "High-speed implementation of privacy amplification in quantum key distribution," in *Proc. 6th Int. Conf. Quantum Cryptograp.*, 2016, p. 1.
- [152] S.-S. Yang, Z.-L. Bai, X.-Y. Wang, and Y.-M. Li, "FPGA-based implementation of size-adaptive privacy amplification in quantum key distribution," *IEEE Photon. J.*, vol. 9, no. 6, pp. 1–8, Dec. 2017.
- [153] J. Zhang, A. Marshall, R. Woods, and T. Q. Duong, "Design of an OFDM physical layer encryption scheme," *IEEE Trans. Veh. Technol.*, vol. 66, no. 3, pp. 2114–2127, Mar. 2017.
- [154] Z. Hao, Y. Mao, S. Zhong, L. E. Li, H. Yao, and N. Yu, "Toward wireless security without computational assumptions—Oblivious transfer based on wireless channel characteristics," *IEEE Trans. Comput.*, vol. 63, no. 6, pp. 1580–1593, Jun. 2014.
- [155] Y. Zhang, Y. Xiang, and X. Huang, "Password-authenticated group key exchange: A cross-layer design," *ACM Trans. Internet Technol.*, vol. 16, no. 4, p. 24, 2016.
- [156] Y. Zhang, Y. Xiang, and X. Huang, "A cross-layer key establishment model for wireless devices in cyber-physical systems," in *Proc. 3rd ACM Workshop Cyber-Phys. Syst. Secur.*, 2017, pp. 43–53.
- [157] A. J. Majid, H. Moradi, and B. Farhang-Boroujeny, "Fault tolerant key generation and secure spread spectrum communication," *IEEE Trans. Wireless Commun.*, vol. 16, no. 8, pp. 5467–5480, Aug. 2017.
- [158] M. Wilhelm, I. Martinovic, E. Uzun, and J. B. Schmitt, "SUDOKU: Secure and usable deployment of keys on wireless sensors," in *Proc. 6th IEEE Workshop Secure Netw. Protocols*, Kyoto, Japan, Oct. 2010, pp. 1–6.
- [159] K.-F. Krentz and G. Wunder, "6doku: Towards secure over-the-air preloading of 6LoWPAN nodes using phy key generation," in *Proc. Eur. Conf. Smart Objects, Syst. Technol.*, Aachen, Germany, Jul. 2015, pp. 1–11.
- [160] Y. Zhang, X. Huang, X. Chen, L. Y. Zhang, J. Zhang, and Y. Xiang, "A hybrid key agreement scheme for smart homes using the merkle puzzle," *IEEE Internet Things J.*, vol. 7, no. 2, pp. 1061–1071, Feb. 2020.
- [161] *IEEE Standard for Air Interface for Broadband Wireless Access Systems*, IEEE Standard 802.16, 2012.
- [162] (2004). *MAX2828/MX2829 Single-/Dual-Band 802.11 A/B/G World-Band Transceiver ICs*. Accessed: Apr. 21, 2020. [Online]. Available: <http://datasheets.maximintegrated.com/en/ds/MAX2828-MAX2829.pdf>
- [163] R. Guillaume, F. Winzer, A. Czylwik, C. T. Zenger, and C. Paar, "Bringing PHY-based key generation into the field: An evaluation for practical scenarios," in *Proc. IEEE 82nd Veh. Technol. Conf. (VTC-Fall)*, Boston, MA, USA, Sep. 2015, pp. 1–5.
- [164] (2015). *SX1276/77/78/79-137 MHz to 1020 MHz Low Power Long Range Transceiver*. Accessed: Apr. 21, 2020. [Online]. Available: <https://www.semtech.com/products/wireless-rf/loras-transceivers/sx1276>
- [165] H. Li, C. Shen, Y. Zhao, G. Sahin, H.-A. Choi, and Y. Shah, "High entropy secrecy generation from wireless CIR," *J. Commun. Netw.*, vol. 21, no. 2, pp. 177–191, Apr. 2019.
- [166] R. Wilson, D. Tse, and R. A. Scholtz, "Channel identification: Secret sharing using reciprocity in ultrawideband channels," *IEEE Trans. Inf. Forensics Security*, vol. 2, no. 3, pp. 364–375, Sep. 2007.
- [167] M. Ghoreishi Madiseh, S. He, M. L. Mcguire, S. W. Neville, and X. Dong, "Verification of secret key generation from UWB channel observations," in *Proc. IEEE Int. Conf. Commun. (ICC)*, Dresden, Germany, Jun. 2009, pp. 1–5.
- [168] S. T.-B. Hamida, J.-B.-I. Pierrot, and C. Castelluccia, "An adaptive quantization algorithm for secret key generation using radio channel measurements," in *Proc. 3rd Int. Conf. New Technol., Mobility Secur. (NTMS)*, Cairo, Egypt, Dec. 2009, pp. 1–5.
- [169] S. T.-B. Hamida, J.-B. Pierrot, and C. Castelluccia, "Empirical analysis of UWB channel characteristics for secret key generation in indoor environments," in *Proc. 21st Annu. IEEE Int. Symp. Pers., Indoor Mobile Radio Commun.*, Istanbul, Turkey, Sep. 2010, pp. 1984–1989.

- [170] F. Marino, E. Paolini, and M. Chiani, "Secret key extraction from a UWB channel: Analysis in a real environment," in *Proc. IEEE Int. Conf. Ultra-WideBand (ICUWB)*, Paris, France, Sep. 2014, pp. 80–85.
- [171] J. Huang and T. Jiang, "Secret key generation exploiting ultra-wideband indoor wireless channel characteristics," *Secur. Commun. Netw.*, vol. 8, no. 13, pp. 2329–2337, Sep. 2015.
- [172] H. Koorapaty, A. A. Hassan, and S. Chennakeshu, "Secure information transmission for mobile radio," *IEEE Commun. Lett.*, vol. 4, no. 2, pp. 52–55, Feb. 2000.
- [173] A. Sayeed and A. Perrig, "Secure wireless communications: Secret keys through multipath," in *Proc. IEEE Int. Conf. Acoust., Speech Signal Process. (ICASSP)*, Las Vegas, NV, USA, Apr. 2008, pp. 3013–3016.
- [174] Q. Wang, H. Su, K. Ren, and K. Kim, "Fast and scalable secret key generation exploiting channel phase randomness in wireless networks," in *Proc. 30th IEEE Int. Conf. Comput. Commun. (INFOCOM)*, Shanghai, China, Apr. 2011, pp. 1422–1430.
- [175] Q. Wang, K. Xu, and K. Ren, "Cooperative secret key generation from phase estimation in narrowband fading channels," *IEEE J. Sel. Areas Commun.*, vol. 30, no. 9, pp. 1666–1674, Oct. 2012.
- [176] H. Zhu, Y. Zhuo, Q. Liu, and S. Chang, "[J]-Splicer: Perceiving accurate CSI phases with commodity WiFi devices," *IEEE Trans. Mobile Comput.*, vol. 17, no. 9, pp. 2155–2165, Sep. 2018.
- [177] Ettus Research. Accessed: Apr. 21, 2020. [Online]. Available: <http://www.ettus.com>
- [178] W. Xi, X.-Y. Li, C. Qian, J. Han, S. Tang, J. Zhao, and K. Zhao, "KEEP: Fast secret key extraction protocol for D2D communication," in *Proc. IEEE 22nd Int. Symp. Qual. Service (IWQoS)*, Hong Kong, May 2014, pp. 350–359.
- [179] D. Halperin, W. Hu, A. Sheth, and D. Wetherall, "Tool release: Gathering 802.11N traces with channel state information," *ACM SIGCOMM Comput. Commun. Rev.*, vol. 41, no. 1, p. 53, 2011.
- [180] Y. Xie, Z. Li, and M. Li, "Precise power delay profiling with commodity WiFi," in *Proc. 21st Annu. Int. Conf. Mobile Comput. Netw. (MobiCom)*, Paris, France, 2015, p. 53–64.
- [181] M. F. Haroun and T. A. Gulliver, "Secret key generation using chaotic signals over frequency selective fading channels," *IEEE Trans. Inf. Forensics Security*, vol. 10, no. 8, pp. 1764–1775, Aug. 2015.
- [182] T. S. Rappaport, *Wireless Communications: Principles and Practice*, 2nd ed. Upper Saddle River, NJ, USA: Prentice-Hall, 2001.
- [183] O. Gungor, F. Chen, and C. E. Koksal, "Secret key generation via localization and mobility," *IEEE Trans. Veh. Technol.*, vol. 64, no. 6, pp. 2214–2230, Jun. 2015.
- [184] X. Zhu, F. Xu, E. Novak, C. C. Tan, Q. Li, and G. Chen, "Using wireless link dynamics to extract a secret key in vehicular scenarios," *IEEE Trans. Mobile Comput.*, vol. 16, no. 7, pp. 2065–2078, Jul. 2017.
- [185] J. Wan, A. Lopez, and M. A. A. Faruque, "Physical layer key generation: Securing wireless communication in automotive cyber-physical systems," *ACM Trans. Cyber-Phys. Syst.*, vol. 3, no. 2, p. 13, 2019.
- [186] P. Huang and X. Wang, "Fast secret key generation in static wireless networks: A virtual channel approach," in *Proc. 32nd IEEE Int. Conf. Comput. Commun. (INFOCOM)*, Turin, Italy, Apr. 2013, pp. 2292–2300.
- [187] G. Li, A. Hu, J. Zhang, and B. Xiao, "Security analysis of a novel artificial randomness approach for fast key generation," in *Proc. IEEE GLOBECOM*, Singapore, 2017, pp. 1–6.
- [188] R. Mehmood, J. W. Wallace, and M. A. Jensen, "Key establishment employing reconfigurable antennas: Impact of antenna complexity," *IEEE Trans. Wireless Commun.*, vol. 13, no. 11, pp. 6300–6310, Nov. 2014.
- [189] S. Gollakota and D. Katabi, "Physical layer wireless security made fast and channel independent," in *Proc. 30th IEEE Int. Conf. Comput. Commun. (INFOCOM)*, Shanghai, China, Apr. 2011, pp. 1125–1133.
- [190] Y. S. Cho, J. Kim, W. Y. Yang, and C. G. Kang, *MIMO-OFDM Wireless Communications With*. Hoboken, NJ, USA: Wiley, 2010.
- [191] H. MacLeod, C. Loadman, and Z. Chen, "Experimental studies of the 2.4-GHz ISM wireless indoor channel," in *Proc. IEEE 3rd Annu. Commun. Netw. Services Res. Conf.*, 2005, pp. 63–68.
- [192] L. Yao, S. T. Ali, V. Sivaraman, and D. Ostry, "Decorrelating secret bit extraction via channel hopping in body area networks," in *Proc. IEEE 23rd Int. Symp. Pers., Indoor Mobile Radio Commun. (PIMRC)*, Sydney, Australia, Sep. 2012, pp. 1454–1459.
- [193] S. N. Premnath, J. Croft, N. Patwari, and S. K. Kaseria, "Efficient high-rate secret key extraction in wireless sensor networks using collaboration," *ACM Trans. Sensor Netw.*, vol. 11, no. 1, pp. 1–32, Nov. 2014.
- [194] B. T. Quist and M. A. Jensen, "Maximizing the secret key rate for informed radios under different channel conditions," *IEEE Trans. Wireless Commun.*, vol. 12, no. 10, pp. 5146–5153, Oct. 2013.
- [195] B. T. Quist and M. A. Jensen, "Bound on the key establishment rate for multi-antenna reciprocal electromagnetic channels," *IEEE Trans. Antennas Propag.*, vol. 62, no. 3, pp. 1378–1385, Mar. 2014.
- [196] B. T. Quist and M. A. Jensen, "Optimal channel estimation in beam-formed systems for common-randomness-based secret key establishment," *IEEE Trans. Inf. Forensics Security*, vol. 8, no. 7, pp. 1211–1220, Jul. 2013.
- [197] B. T. Quist and M. A. Jensen, "Maximization of the channel-based key establishment rate in MIMO systems," *IEEE Trans. Wireless Commun.*, vol. 14, no. 10, pp. 5565–5573, Oct. 2015.
- [198] M. G. Madiseh, S. W. Neville, and M. L. McGuire, "Applying beamforming to address temporal correlation in wireless channel characterization-based secret key generation," *IEEE Trans. Inf. Forensics Security*, vol. 7, no. 4, pp. 1278–1287, Aug. 2012.
- [199] S. Baksi and D. C. Popescu, "Secret key generation with precoding and role reversal in MIMO wireless systems," *IEEE Trans. Wireless Commun.*, vol. 18, no. 6, pp. 3104–3112, Jun. 2019.
- [200] X. Zhang and E. W. Knightly, "CSISnoop: Inferring channel state information in multi-user MIMO WLANs," *IEEE/ACM Trans. Netw.*, vol. 27, no. 1, pp. 231–244, Feb. 2019.
- [201] J. Zhang, R. Woods, T. Q. Duong, A. Marshall, and Y. Ding, "Experimental study on channel reciprocity in wireless key generation," in *Proc. IEEE 17th Int. Workshop Signal Process. Adv. Wireless Commun. (SPAWC)*, Edinburgh, U.K., Jul. 2016, pp. 1–5.
- [202] A. J. Pierrot, R. A. Chou, and M. R. Bloch, "Experimental aspects of secret key generation in indoor wireless environments," in *Proc. IEEE 14th Workshop Signal Process. Adv. Wireless Commun. (SPAWC)*, Darmstadt, Germany, Jun. 2013, pp. 669–673.
- [203] C. L. K. Ngassa, R. Molière, F. Delaveau, A. Sibille, and N. Shapira, "Secret key generation scheme from WiFi and LTE reference signals," *Anal. Integr. Circuits Signal Process.*, vol. 91, no. 2, pp. 277–292, May 2017.
- [204] D. Kreiser, Z. Dyka, S. Kornemann, C. Wittke, I. Kabin, O. Stecklina, and P. Langendoerfer, "On wireless channel parameters for key generation in industrial environments," *IEEE Access*, vol. 5, pp. 79010–79025, 2017.
- [205] A. M. Allam, "Channel-based secret key establishment for FDD wireless communication systems," *Commun. Appl. Electron.*, vol. 7, no. 9, pp. 27–31, 2017.
- [206] X. Wu, Y. Peng, C. Hu, H. Zhao, and L. Shu, "A secret key generation method based on CSI in OFDM-FDD system," in *Proc. IEEE GLOBECOM Workshop Trusted Commun. Phys. Layer Secur. (TCPLS)*, Atlanta, GA, USA, Dec. 2013, pp. 1297–1302.
- [207] S. J. Goldberg, Y. C. Shah, and A. Reznik, "Method and apparatus for performing JRNSO in FDD, TDD and MIMO communications," U.S. Patent 8401196, Mar. 19, 2013. Accessed: Apr. 21, 2020. [Online]. Available: <https://www.google.com/patents/US8401196>
- [208] L. Peng, G. Li, J. Zhang, R. Woods, M. Liu, and A. Hu, "An investigation of using loop-back mechanism for channel reciprocity enhancement in secret key generation," *IEEE Trans. Mobile Comput.*, vol. 18, no. 3, pp. 507–519, Mar. 2019.
- [209] B. Liu, A. Hu, and G. Li, "Secret key generation scheme based on the channel covariance matrix eigenvalues in FDD systems," *IEEE Commun. Lett.*, vol. 23, no. 9, pp. 1493–1496, Sep. 2019.
- [210] W. Wang, H. Jiang, X. Xia, P. Mu, and Q. Yin, "A wireless secret key generation method based on chinese remainder theorem in FDD systems," *Sci. China Inf. Sci.*, vol. 55, no. 7, pp. 1605–1616, Jul. 2012.
- [211] G. Li, A. Hu, C. Sun, and J. Zhang, "Constructing reciprocal channel coefficients for secret key generation in FDD systems," *IEEE Commun. Lett.*, vol. 22, no. 12, pp. 2487–2490, Dec. 2018.
- [212] *Evolved Universal Terrestrial Radio Access (E-UTRA); User Equipment (UE) Radio Transmission and Reception*, document Technical Specification 36.101 Release 10, 3GPP, 2017.
- [213] D. Vasisht, S. Kumar, H. Rahul, and D. Katabi, "Eliminating channel feedback in next-generation cellular networks," in *Proc. ACM SIGCOMM Conf.*, Florianopolis, Brazil, Aug. 2016, pp. 398–411.
- [214] D. S. Baum, J. Hansen, and J. Salo, "An interim channel model for beyond-3G systems: Extending the 3GPP spatial channel model (SCM)," in *Proc. IEEE VTC-Spring*, Stockholm, Sweden, vol. 5, Dec. 2005, pp. 3132–3136.

- [215] A. Sabharwal, P. Schniter, D. Guo, D. W. Bliss, S. Rangarajan, and R. Wichman, "In-band full-duplex wireless: Challenges and opportunities," *IEEE J. Sel. Areas Commun.*, vol. 32, no. 9, pp. 1637–1652, Sep. 2014.
- [216] H. Vogt and A. Sezgin, "Full-duplex vs. Half-duplex secret-key generation," in *Proc. IEEE Int. Workshop Inf. Forensics Secur. (WIFS)*, Nov. 2015, pp. 1–6.
- [217] H. Vogt, Z. H. Awan, and A. Sezgin, "Secret-key generation: Full-duplex versus half-duplex probing," *IEEE Trans. Commun.*, vol. 67, no. 1, pp. 639–652, Jan. 2019.
- [218] H. Vogt, K. Ramm, and A. Sezgin, "Practical secret-key generation by full-duplex nodes with residual self-interference," in *Proc. Smart Antennas*, Munich, Germany, Mar. 2016, pp. 1–5.
- [219] R. Jin, X. Du, Z. Deng, K. Zeng, and J. Xu, "Practical secret key agreement for full-duplex near field communications," *IEEE Trans. Mobile Comput.*, vol. 15, no. 4, pp. 938–951, Apr. 2016.
- [220] M. Bulenok, I. Tunaru, L. Biard, B. Denis, and B. Uguen, "Experimental channel-based secret key generation with integrated ultra wideband devices," in *Proc. IEEE 27th Annu. Int. Symp. Pers., Indoor, Mobile Radio Commun. (PIMRC)*, Valencia, Spain, Sep. 2016, pp. 1–6.
- [221] Z. Li, Q. Pei, I. Markwood, Y. Liu, and H. Zhu, "Secret key establishment via RSS trajectory matching between wearable devices," *IEEE Trans. Inf. Forensics Security*, vol. 13, no. 3, pp. 802–817, Mar. 2018.
- [222] K. Moara-Nkwe, Q. Shi, G. M. Lee, and M. H. Eiza, "A novel physical layer secure key generation and refreshment scheme for wireless sensor networks," *IEEE Access*, vol. 6, pp. 11374–11387, 2018.
- [223] R. Cavallari, F. Martelli, R. Rosini, C. Buratti, and R. Verdone, "A survey on wireless body area networks: Technologies and design challenges," *IEEE Commun. Surveys Tuts.*, vol. 16, no. 3, pp. 1635–1657, 3rd Quart., 2014.
- [224] S. Movassaghi, M. Abolhasan, J. Lipman, D. Smith, and A. Jamalipour, "Wireless body area networks: A survey," *IEEE Commun. Surveys Tuts.*, vol. 16, no. 3, pp. 1658–1686, Jan. 2014.
- [225] L. W. Hanlen, D. Smith, J. A. Zhang, and D. Lewis, "Key-sharing via channel randomness in narrowband body area networks: Is everyday movement sufficient?" in *Proc. 4th Int. Conf. Body Area Netw.*, 2009, pp. 1–6.
- [226] Z. Li, H. Wang, and H. Fang, "Group-based cooperation on symmetric key generation for wireless body area networks," *IEEE Internet Things J.*, vol. 4, no. 6, pp. 1955–1963, Dec. 2017.
- [227] B. Han, S. Peng, C. Wu, X. Wang, and B. Wang, "LoRa-based physical layer key generation for secure V2 V/V2I communications," *Sensors*, vol. 20, no. 3, p. 682, Jan. 2020.
- [228] *LoRa Tools, Air Time Calculator*. Accessed: Apr. 21, 2020. [Online]. Available: <https://www.loratools.nl/#airtime>
- [229] C. Lipps, M. Strufe, S. B. Mallikarjun, and H. D. Schotten, "Physical layer security for IIoT and CPPS: A cellular-network security approach," in *Proc. Mobile Commun.-Technol. Appl. ITG-Symp.*, Osnabrueck, Germany, May 2019, pp. 1–5.
- [230] *Sigfox Technical Overview*, 2017.
- [231] *ECDH and ECDSA for 8-Bit, 32-Bit, and 64-Bit Processors*. Accessed: Apr. 21, 2020. [Online]. Available: <https://github.com/kmackay/micro-ecc>
- [232] *A Very Small ECC Implementation for 8-Bit Microcontrollers*. Accessed: Apr. 21, 2020. [Online]. Available: <https://github.com/iSECPartners/nano-ecc>
- [233] *WARP Project*. Accessed: Apr. 21, 2020. [Online]. Available: <http://warpproject.org>
- [234] *WARP 802.11 Reference Design: Experiments Framework*. Accessed: Apr. 21, 2020. [Online]. Available: http://warpproject.org/trac/wiki/802.11/wlan_exp
- [235] Hash Functions. *National Institute of Standards and Technology*. Accessed: Apr. 21, 2020. [Online]. Available: <https://csrc.nist.gov/projects/hash-functions>
- [236] *Prophylaxe Project*. Accessed: Apr. 21, 2020. [Online]. Available: <https://www.ict-prophylaxe.de/>
- [237] C. Zenger, "Physical-layer security for the Internet of Things," Ph.D. dissertation, Ruhr Univ. Bochum, Bochum, Germany, 2017. Accessed: Apr. 21, 2020. [Online]. Available: <https://d-nb.info/1127335170/34>
- [238] *SoftMAC*. Accessed: Apr. 21, 2020. [Online]. Available: <https://wireless.wiki.kernel.org/en/developers/documentation/glossary#softmac>
- [239] *Radiotap*. Accessed: Apr. 21, 2020. [Online]. Available: <https://www.radiotap.org/>
- [240] *FullMAC*. Accessed: Apr. 21, 2020. [Online]. Available: <https://wireless.wiki.kernel.org/en/developers/documentation/glossary#fullmac>
- [241] *Wcn36xx*. Accessed: Apr. 21, 2020. [Online]. Available: <https://wireless.wiki.kernel.org/en/users/drivers/wcn36xx>
- [242] M. Gast, *802.11 Wireless Networks: The Definitive Guide*. Newton, MA, USA: O'Reilly Media, 2005. Accessed: Apr. 21, 2020. [Online]. Available: <https://www.oreilly.com/library/view/80211-wireless-networks/0596100523%2fch04.html>
- [243] C. Ye and A. Reznik, "Group secret key generation algorithms," in *Proc. IEEE Int. Symp. Inf. Theory (ISIT)*, Nice, France, Jun. 2007, pp. 2596–2600.
- [244] S. Xiao, Y. Guo, K. Huang, and L. Jin, "Cooperative group secret key generation based on secure network coding," *IEEE Commun. Lett.*, vol. 22, no. 7, pp. 1466–1469, Jul. 2018.
- [245] R. Jin, X. Du, K. Zeng, L. Huang, L. Xiao, and J. Xu, "Delay analysis of physical-layer key generation in dynamic roadside-to-vehicle networks," *IEEE Trans. Veh. Technol.*, vol. 66, no. 3, pp. 2526–2535, Mar. 2017.
- [246] Y. Wei, C. Zhu, and J. Ni, "Group secret key generation algorithm from wireless signal strength," in *Proc. 6th Int. Conf. Internet Comput. Sci. Eng.*, Apr. 2012, pp. 239–245.
- [247] C. D. T. Thai, J. Lee, J. Prakash, and T. Q. S. Quek, "Secret group-key generation at physical layer for multi-antenna mesh topology," *IEEE Trans. Inf. Forensics Security*, vol. 14, no. 1, pp. 18–33, Jan. 2019.
- [248] P. Xu, K. Cumanan, Z. Ding, X. Dai, and K. K. Leung, "Group secret key generation in wireless networks: Algorithms and rate optimization," *IEEE Trans. Inf. Forensics Security*, vol. 11, no. 8, pp. 1831–1846, Aug. 2016.
- [249] H. Nagubandi and J. Harshan, "RASI: Relay-assisted physical-layer key generation in unmanned aerial vehicles," in *Proc. IEEE 87th Veh. Technol. Conf. (VTC Spring)*, Jun. 2018, pp. 1–5.
- [250] L. Lai, Y. Liang, and W. Du, "Cooperative key generation in wireless networks," *IEEE J. Sel. Areas Commun.*, vol. 30, no. 8, pp. 1578–1588, Sep. 2012.
- [251] N. Wang, N. Zhang, and T. A. Gulliver, "Cooperative key agreement for wireless networking: Key rates and practical protocol design," *IEEE Trans. Inf. Forensics Security*, vol. 9, no. 2, pp. 272–284, Feb. 2014.
- [252] T. Shimizu, H. Iwai, and H. Sasaoka, "Physical-layer secret key agreement in two-way wireless relaying systems," *IEEE Trans. Inf. Forensics Security*, vol. 6, no. 3, pp. 650–660, Sep. 2011.
- [253] H. Zhou, L. M. Huie, and L. Lai, "Secret key generation in the two-way relay channel with active attackers," *IEEE Trans. Inf. Forensics Security*, vol. 9, no. 3, pp. 476–488, Mar. 2014.
- [254] K. Chen, B. B. Natarajan, and S. Shattil, "Secret key generation rate with power allocation in relay-based LTE-A networks," *IEEE Trans. Inf. Forensics Security*, vol. 10, no. 11, pp. 2424–2434, Nov. 2015.
- [255] C. D. T. Thai, J. Lee, and T. Q. S. Quek, "Physical-layer secret key generation with colluding untrusted relays," *IEEE Trans. Wireless Commun.*, vol. 15, no. 2, pp. 1517–1530, Feb. 2016.
- [256] M. Waqas, M. Ahmed, Y. Li, D. Jin, and S. Chen, "Social-aware secret key generation for secure Device-to-Device communication via trusted and non-trusted relays," *IEEE Trans. Wireless Commun.*, vol. 17, no. 6, pp. 3918–3930, Jun. 2018.
- [257] Y. Ding, J. Zhang, and V. F. Fusco, "Retrodirective-assisted secure wireless key establishment," *IEEE Trans. Commun.*, vol. 65, no. 1, pp. 320–334, Jan. 2017.
- [258] X. He, H. Dai, W. Shen, P. Ning, and R. Dutta, "Toward proper guard zones for link signature," *IEEE Trans. Wireless Commun.*, vol. 15, no. 3, pp. 2104–2117, Mar. 2016.
- [259] M. Edman, A. Kiayias, Q. Tang, and B. Yener, "On the security of key extraction from measuring physical quantities," *IEEE Trans. Inf. Forensics Security*, vol. 11, no. 8, pp. 1796–1806, Aug. 2016.
- [260] C. Zenger, H. Vogt, J. Zimmer, A. Sezgin, and C. Paar, "The passive eavesdropper affects my channel: Secret-key rates under real-world conditions," in *Proc. IEEE Globecom Workshops (GC Wkshps)*, Dec. 2016, pp. 1–6.
- [261] R. Dautov and G. R. Tsouri, "Effects of passive negative correlation attack on sensors utilizing physical key extraction in indoor wireless body area networks," *IEEE Sensors Lett.*, vol. 3, no. 7, pp. 1–4, Jul. 2019.
- [262] Z. Ji, Y. Zhang, Z. He, K. Lin, B. Li, P. L. Yeoh, and H. Yin, "Vulnerabilities of physical layer secret key generation against environment reconstruction based attacks," *IEEE Wireless Commun. Lett.*, vol. 9, no. 5, pp. 693–697, May 2020.

- [263] H. Liu, Y. Wang, J. Liu, J. Yang, Y. Chen, and H. V. Poor, "Authenticating users through fine-grained channel information," *IEEE Trans. Mobile Comput.*, vol. 17, no. 2, pp. 251–264, Feb. 2018.
- [264] A. Mahmood and M. A. Jensen, "Impact of array mutual coupling on multiantenna propagation-based key establishment," *IEEE Trans. Antennas Propag.*, vol. 63, no. 11, pp. 5063–5071, Nov. 2015.
- [265] M. Zafer, D. Agrawal, and M. Srivatsa, "Limitations of generating a secret key using wireless fading under active adversary," *IEEE/ACM Trans. Netw.*, vol. 20, no. 5, pp. 1440–1451, Oct. 2012.
- [266] S. Eberz, M. Strohmeier, M. Wilhelm, and I. Martinovic, "A practical man-in-the-middle attack on signal-based key generation protocols," in *Proc. Eur. Symp. Res. Comput. Secur.*, 2012, pp. 235–252.
- [267] R. Jin and K. Zeng, "Physical layer key agreement under signal injection attacks," in *Proc. IEEE Conf. Commun. Netw. Secur. (CNS)*, Florence, Italy, Sep. 2015, pp. 254–262.
- [268] R. Jin and K. Zeng, "Manipulative attack against physical layer key agreement and countermeasure," *IEEE Trans. Dependable Secure Comput.*, early access, Jan. 25, 2019, doi: 10.1109/TDSC.2019.2895325.
- [269] E. V. Belmega and A. Chorti, "Protecting secret key generation systems against jamming: Energy harvesting and channel hopping approaches," *IEEE Trans. Inf. Forensics Security*, vol. 12, no. 11, pp. 2611–2626, Nov. 2017.
- [270] Q. Hu, B. Du, K. Markantonakis, and G. P. Hancke, "A session hijacking attack against a device-assisted physical-layer key agreement," *IEEE Trans. Ind. Informat.*, vol. 16, no. 1, pp. 691–702, Jan. 2020.
- [271] L. Shi, J. Yuan, S. Yu, and M. Li, "ASK-BAN: Authenticated secret key extraction utilizing channel characteristics for body area networks," in *Proc. 6th ACM Conf. Secur. Privacy Wireless Mobile Netw.*, 2013, pp. 155–166.
- [272] L. Shi, J. Yuan, S. Yu, and M. Li, "MASK-BAN: Movement-aided authenticated secret key extraction utilizing channel characteristics in body area networks," *IEEE Internet Things J.*, vol. 2, no. 1, pp. 52–62, Feb. 2015.
- [273] X. Wang, P. Hao, and L. Hanzo, "Physical-layer authentication for wireless security enhancement: Current challenges and future developments," *IEEE Commun. Mag.*, vol. 54, no. 6, pp. 152–158, Jun. 2016.
- [274] L. Xiao, L. Greenstein, N. Mandayam, and W. Trappe, "Using the physical layer for wireless authentication in time-variant channels," *IEEE Trans. Wireless Commun.*, vol. 7, no. 7, pp. 2571–2579, Jul. 2008.
- [275] Y. Chen, J. Yang, W. Trappe, and R. P. Martin, "Detecting and localizing identity-based attacks in wireless and sensor networks," *IEEE Trans. Veh. Technol.*, vol. 59, no. 5, pp. 2418–2434, Jun. 2010.
- [276] Q. Li, H. Fan, W. Sun, J. Li, L. Chen, and Z. Liu, "Fingerprints in the air: Unique identification of wireless devices using RF RSS fingerprints," *IEEE Sensors J.*, vol. 17, no. 11, pp. 3568–3579, Jun. 2017.
- [277] J. Liu and X. Wang, "Physical layer authentication enhancement using two-dimensional channel quantization," *IEEE Trans. Wireless Commun.*, vol. 15, no. 6, pp. 4171–4182, Jun. 2016.
- [278] H. Fang, X. Wang, and L. Hanzo, "Learning-aided physical layer authentication as an intelligent process," *IEEE Trans. Commun.*, vol. 67, no. 3, pp. 2260–2273, Mar. 2019.
- [279] W. Trappe, "The challenges facing physical layer security," *IEEE Commun. Mag.*, vol. 53, no. 6, pp. 16–20, Jun. 2015.
- [280] B. Danev, D. Zanetti, and S. Capkun, "On physical-layer identification of wireless devices," *ACM Comput. Surveys*, vol. 45, no. 1, pp. 1–29, Nov. 2012.
- [281] Q. Xu, R. Zheng, W. Saad, and Z. Han, "Device fingerprinting in wireless networks: Challenges and opportunities," *IEEE Commun. Surveys Tuts.*, vol. 18, no. 1, pp. 94–104, 1st Quart., 2016.
- [282] S. Riyaz, K. Sankhe, S. Ioannidis, and K. Chowdhury, "Deep learning convolutional neural networks for radio identification," *IEEE Commun. Mag.*, vol. 56, no. 9, pp. 146–152, Sep. 2018.
- [283] H. J. Patel, M. A. Temple, and R. O. Baldwin, "Improving ZigBee device network authentication using ensemble decision tree classifiers with radio frequency distinct native attribute fingerprinting," *IEEE Trans. Rel.*, vol. 64, no. 1, pp. 221–233, Mar. 2015.
- [284] G. Huang, Y. Yuan, X. Wang, and Z. Huang, "Specific emitter identification based on nonlinear dynamical characteristics," *Can. J. Electr. Comput. Eng.*, vol. 39, no. 1, pp. 34–41, 2016.
- [285] T. D. Vo-Huu, T. D. Vo-Huu, and G. Noubir, "Fingerprinting Wi-Fi devices using software defined radios," in *Proc. 9th ACM Conf. Secur. Privacy Wireless Mobile Netw.*, 2016, pp. 3–14.
- [286] V. Brik, S. Banerjee, M. Gruteser, and S. Oh, "Wireless device identification with radiometric signatures," in *Proc. ACM Int. Conf. Mobile Comput. Netw. (MobiCOM)*, San Francisco, USA, Sep. 2008, pp. 116–127.
- [287] L. Peng, A. Hu, J. Zhang, Y. Jiang, J. Yu, and Y. Yan, "Design of a hybrid RF fingerprint extraction and device classification scheme," *IEEE Internet Things J.*, vol. 6, no. 1, pp. 349–360, Feb. 2019.
- [288] L. Peng, J. Zhang, M. Liu, and A. Hu, "Deep learning based RF fingerprint identification using differential constellation trace figure," *IEEE Trans. Veh. Technol.*, vol. 69, no. 1, pp. 1091–1095, Jan. 2020.
- [289] J. Yu, A. Hu, G. Li, and L. Peng, "A robust RF fingerprinting approach using multisampling convolutional neural network," *IEEE Internet Things J.*, vol. 6, no. 4, pp. 6786–6799, Aug. 2019.
- [290] G. Li, J. Yu, Y. Xing, and A. Hu, "Location-invariant physical layer identification approach for WiFi devices," *IEEE Access*, vol. 7, pp. 106974–106986, 2019.
- [291] Y. Xing, A. Hu, J. Zhang, L. Peng, and G. Li, "On radio frequency fingerprint identification for DSSS systems in low SNR scenarios," *IEEE Commun. Lett.*, vol. 22, no. 11, pp. 2326–2329, Nov. 2018.
- [292] J. Huang, W. Albazraq, and G. Xing, "BlueID: A practical system for Bluetooth device identification," in *Proc. IEEE INFOCOM*, Apr. 2014, pp. 2849–2857.
- [293] P. Robyns, E. Marin, W. Lamotte, P. Quax, D. Singelée, and B. Preneel, "Physical-layer fingerprinting of LoRa devices using supervised and zero-shot learning," in *Proc. 10th ACM Conf. Secur. Privacy Wireless Mobile Netw.*, 2017, pp. 58–63.
- [294] R. Das, A. Gadre, S. Zhang, S. Kumar, and J. M. Moura, "A deep learning approach to IoT authentication," in *Proc. IEEE ICC*, Kansas City, MO, USA, May 2018, pp. 1–6.
- [295] Y. Jiang, L. Peng, A. Hu, S. Wang, Y. Huang, and L. Zhang, "Physical layer identification of LoRa devices using constellation trace figure," *EURASIP J. Wireless Commun. Netw.*, vol. 2019, no. 1, p. 223, Dec. 2019.
- [296] W. Wang, Z. Sun, S. Piao, B. Zhu, and K. Ren, "Wireless physical-layer identification: Modeling and validation," *IEEE Trans. Inf. Forensics Security*, vol. 11, no. 9, pp. 2091–2106, Sep. 2016.
- [297] W. Wang, Z. Sun, K. Ren, and B. Zhu, "User capacity of wireless physical-layer identification," *IEEE Access*, vol. 5, pp. 3353–3368, 2017.
- [298] P. Robyns, P. Quax, and W. Lamotte, "PHY-layer security is no alternative to cryptography," in *Proc. 10th ACM Conf. Secur. Privacy Wireless Mobile Netw.*, 2017, pp. 160–162.
- [299] W. Trappe, R. Howard, and R. S. Moore, "Low-energy security: Limits and opportunities in the Internet of Things," *IEEE Secur. Privacy*, vol. 13, no. 1, pp. 14–21, Jan. 2015.
- [300] L. Jiao, J. Tang, and K. Zeng, "Physical layer key generation using virtual AoA and AoD of mmwave massive MIMO channel," in *Proc. IEEE Conf. Commun. Netw. Secur. (CNS)*, Beijing, China, May 2018, pp. 1–9.
- [301] L. Jiao, N. Wang, and K. Zeng, "Secret beam: Robust secret key agreement for mmWave massive MIMO 5G communication," in *Proc. IEEE GLOBECOM*, Abu Dhabi, United Arab Emirates, Dec. 2018, pp. 1–6.
- [302] S.-K. Liao et al., "Satellite-to-ground quantum key distribution," *Nature*, vol. 549, no. 7670, pp. 43–47, 2017.



JUNQING ZHANG received the B.Eng. and M.Eng. degrees in electrical engineering from Tianjin University, China, in 2009 and 2012, respectively, and the Ph.D. degree in electronics and electrical engineering from Queen's University Belfast, U.K., in 2016. He is currently a Lecturer (Assistant Professor) with the University of Liverpool, U.K. His research interests include the Internet of Things, wireless security, physical layer security, key generation, and radio-frequency fingerprinting identification.



GUYUE LI (Member, IEEE) received the B.S. degree in information science and technology and the Ph.D. degree in information security from Southeast University, Nanjing, China, in 2011 and 2017, respectively. She is currently a Lecturer at Southeast University. Her research interests include physical layer security, secret key generation, radio-frequency fingerprint, and link signature.



AIQUN HU (Member, IEEE) received the B.Sc.(Eng.), M.Eng.Sc., and Ph.D. degrees from Southeast University, in 1987, 1990, and 1993, respectively. He was invited as a Postdoctoral Research Fellow at The University of Hong Kong, from 1997 to 1998, and a TCT Fellow at Nanyang Technological University, in 2006. His research interests include data transmission and secure communication technology. He has published two books and over 100 technical articles in the wireless communications field.



ALAN MARSHALL (Senior Member, IEEE) has spent over 25 years working in the telecommunications and defense industries and in Academia. He currently holds the Chair in Communications Networks at the University of Liverpool, where he is also the Head of the Department of Electrical Engineering and Electronics and the Director of the Advanced Networks Group. He has published over 250 scientific articles and holds a number of joint patents in the areas of communications and network security. He formed a successful spin-out company Traffic Observation & Management (TOM) Ltd., specializing in intrusion detection and prevention for wireless networks. His research interests include network architectures and protocols, mobile and wireless networks, network security, machine-to-machine communications and trust systems, high-speed packet switching, quality of service and experience (QoS/QoE), and distributed haptics and multi-sensory communications. He is a Section Editor (Section B: Computer and Communications Networks and Systems) of the *Computer Journal* of the British Computer Society and sits on the program committees of a number of the IEEE conferences. He is the U.K. Lead for the UK-Jiangsu 20+20 world-class universities initiative.



LAJOS HANZO (Fellow, IEEE) received the master's and Ph.D. degrees from the Technical University (TU) of Budapest, in 1976 and 1983, respectively. He was also awarded the Honorary Doctorates by the TU of Budapest, in 2009, and by The University of Edinburgh, in 2015. He is a Foreign Member of the Hungarian Academy of Sciences and the former Editor-in-Chief of the IEEE Press. He has served as the Governor of the IEEE ComSoc and VTS. He has published over 1900 contributions at the IEEE Xplore and 19 Wiley-IEEE Press books and has helped the fast-track career of 119 Ph.D. students. Over 40 of them are professors at various stages of their careers in academia, and many of them are leading scientists in the wireless industry. He is a Fellow of the REng, IET, and EURASIP. More information can be found in <http://www-mobile.ecs.soton.ac.uk> and https://en.wikipedia.org/wiki/Lajos_Hanzo.

...