

Received June 7, 2020, accepted June 23, 2020, date of publication July 3, 2020, date of current version July 16, 2020.

Digital Object Identifier 10.1109/ACCESS.2020.3006887

A Comprehensive Study on IoT Based Accident Detection Systems for Smart Vehicles

UNAIZA ALVI¹, MUAZZAM A. KHAN KHATTAK², (Senior Member, IEEE),
BALAWAL SHABIR¹, ASAD WAQAR MALIK¹, (Senior Member, IEEE),
AND SHER RAMZAN MUHAMMAD³

¹Department of Computing, School of Electrical Engineering and Computer Science (SECS), National University of Sciences and Technology (NUST), Islamabad 44000, Pakistan

²Department of Computer Science, Quaid-i-Azam University, Islamabad 45320, Pakistan

³Faculty of Computing and Information Technology (FCIT), King Abdulaziz University, Jeddah 21589, Saudi Arabia

Corresponding author: Muazzam A. Khan Khattak (khattakmuazzam@gmail.com)

ABSTRACT With population growth, the demand for vehicles has increased tremendously, which has created an alarming situation in terms of traffic hazards and road accidents. The road accidents percentage is growing exponentially and so are the fatalities caused due to accidents. However, the primary cause of the increased rate of fatalities is due to the delay in emergency services. Many lives could be saved with efficient rescue services. The delay happens due to traffic congestion or unstable communication to the medical units. The implementation of automatic road accident detection systems to provide timely aid is crucial. Many solutions have been proposed in the literature for automatic accident detection. The techniques include crash prediction using smartphones, vehicular ad-hoc networks, GPS/GSM based systems, and various machine learning techniques. With such high rates of deaths associated with road accidents, road safety is the most critical sector that demands significant exploration. In this paper, we present a critical analysis of various existing methodologies used for predicting and preventing road accidents, highlighting their strengths, limitations, and challenges that need to be addressed to ensure road safety and save valuable lives.

INDEX TERMS GSM, GPS, accident detection, IoT, smart cities.

NOMENCLATURE

AC	Alcohol Check
Acc	Accuracy
Accel	Accelerometer
ADANN	Accident Detection using Artificial Neural Network
ADFL	Accident Detection using Fuzzy Logic
AL	Alcohol
APSVM	Accident Prediction using Support Vector Machine
AR	Automatic Reporting
D	Distance
DBA	Driver Behaviour Analysis
DBT	Deceleration Based on Traffic signals
DC	Drowsiness Check
DDDD	Drowsy and Drunk Driving Detection

DDRL	Drowsiness Detection using Representation Learning
DIDCNN	Distraction Identification with Deep Convolutional Neural Network
DLC	Driver License Check
FPR	False Positive Rate
H	High
IR	Infrared Sensor
L	Low
LS	Limit Switches
M	Medium
MC	Micro-controller
ML/AI	Machine Learning/Artificial Intelligence
N	No
N/A	Not Applicable
P	Pressure
PDCNN	Pedestrian Detection with Convolutional Neural Network
RF	Radio Frequency
RP	Raspberry Pi

The associate editor coordinating the review of this manuscript and approving it for publication was Alessandra De Benedictis.

S	Speed
SB	Seat Belt
SBC	Seat Belt Check
SC	Speed Check
SDO	Safe distance from Obstacles
SH	Smart Helmet
STF	Switch to Terminate False alarm
Temp	Temperature
UAS	Using Accelerometer Sensors
UCSA	Using Cell phone, Speed and Accelerometer sensors
UDS	Using Distance Sensors
UGG	Using GPS and GSM
UGGARFT	Using Gyroscope, GPS, android app and RF transmitter
ULS	Using Limit Switches
UPS	Using Piezoelectric Sensors
UPST	Using Pressure Sensor and Tilt angle
USSG	Using Shock Sensors and GPS
UVS	Using Vibration Sensors
V	Vibration
VBA	Vehicle Behaviour Analysis
Y	Yes

I. INTRODUCTION

Due to rapid growth of world population, the demand for vehicles has increased tremendously, resultantly problems of traffic congestion and road accidents has also increased. The general population's life is under high risk, if any accident occurs there's a long reaction time which increments the number of deaths, therefore an automatic accident detection system must exist to overcome this situation. Statistics show that leading cause of death by injury is road accidents [1]. There can be multiple causes of road accidents, some of them are, driver negligence due to drowsiness [2], driving while intoxicated [3], over speeding [4], [5] etc. Some studies show that weather conditions can also contribute towards the severity of an accident such as fog, rain, high winds. High winds can directly influence the vehicle which may deviate the vehicle from road, or indirectly due to obstruction dangers present on the roads such as trees, walls etc., [6].

Road crashes can be seen as a collision between any on-road vehicles, obstacles or pedestrians. The survival rate of victim is highly reliant on how long an ambulance takes to reach the site of the accident and then carry the patient to the hospital. In most cases of road accidents, the injuries are not severe and the life of the victim can be rescued, however due to late arrival of the rescue teams, the injuries turn deadly. Thus, the main goal is to identify where the accident occurred, send the information to the rescue teams in considerably less time, so that they can take the necessary actions, to save the life of victim [7].

Intelligent Transport Systems (ITS) based on Internet of Things (IoT) are getting popular and can be seen as a solution to improve the road safety. One effective technique to reduce traffic hazards and save precious lives could be to reduce

the response time after an accident has occurred. Significant research has been carried out to address this issue and to minimize the response time following an accident [1]. Different approaches are used for this purpose. In this context, VANET (Vehicular Ad-hoc Network) can be utilized [8], [9], in which every moving vehicle acts as a node. On occurrence of accident, the alert messages are communicated via RF (Radio Frequency) module [10]. One approach uses limit switches to detect an accident, GSM (Global System for Mobile Communications) is used to send an alert message and location of accident is traced by GPS (Global Positioning System) module [11]. Smartphone based systems that use an android app to detect vehicle crash are also proposed. These systems measure change of tilt angle by means of an accelerometer sensor, speed by means of GPS and send an alert on detection of accident [12]. Some systems focus on preventive strategy because at the end, goal is to save lives. This system particularly focuses on the safety of two wheelers and checks if the driver is drowsy [2]. One technique focuses on using the accelerometer sensor, by monitoring the vehicle speed and report an accident as it reaches below the threshold point [13]. Another approach aims on preventing drunken driving by installing alcohol sensors on the steering wheel and not allowing the driver to drive if he's intoxicated by measuring the alcohol content in his oxygen [3], [14].

In this approach, data is obtained from various sensors and event logs to extract prominent features for collision detection model. Various intelligent computational models are used to detect accidents. These models include nearest neighbor, neural networks and regression trees [15]. Vehicle behaviors can be analyzed given its position and velocity values, and can be helpful in the detection of accidents. To detect an accident and to distinguish it from normal cases, different machine learning algorithms like Support Vector Machine (SVM), Artificial Neural Network (ANN) and Random Forests (RF) are implemented on traffic data [16]. Machine learning techniques can also be utilized to determine the severity of accident. Different algorithms such as k-means clustering, SVM under reinforcement learning by fetching real time data like velocity which is obtained by means of vibration sensors installed in vehicle and distance which is obtained by means of ultrasonic sensors [17]. Accidents can also be detected by pre-trained surveillance cameras installed on the highways [18], as illustrated in Figure 1. Another machine learning approach uses fuzzy logic. Data like number of vehicles in each zone, speed of cars in particular lanes etc. is collected and then decisions are made accordingly. In this technique, a situation is detected as an accident whenever there's some sort of disturbance in surrounding lanes [19].

Many systems focused on taking preventive measures, along with detection to avoid accidents such as controlling the speed, checking driver license etc. Various approaches have been used for this such as smartphones, VANETs, vibration sensors, pressure sensors, GPS, GSM and various machine learning algorithms. Even though there is literature available on various strategies for accident detection and prevention;

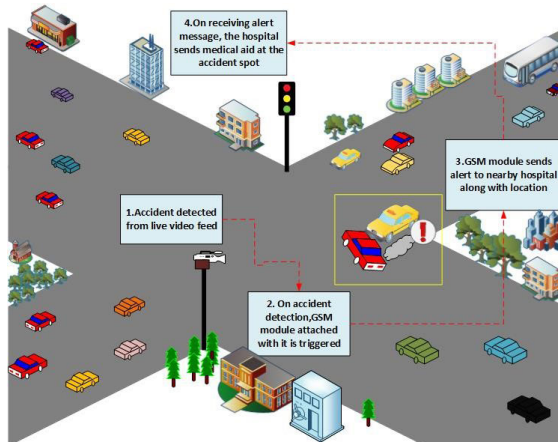

FIGURE 1. Real time accident detection using surveillance cameras.

however, no comprehensive survey exists. This paper aims to fill this gap by critically reviewing the literature related to accident detection, prevention, and reporting systems, to provide a broader perspective of existing techniques so that effective systems can be developed that can utilize the strengths while addressing the challenges in the current systems.

The rest of this article is arranged as follows. Motivation behind this work is discussed in Section II, Section III covers the IoT characteristics, IoT applications in various domains are discussed in Section IV, Section V covers the typical challenges in an IoT environment, the emerging IoT technologies are discussed in Section VI, Section VII covers the literature review of various accident detection and prevention techniques, Section VIII presents a comparative study of different techniques, Section IX presents recommendations based on the analysis and finally the paper is concluded in Section X.

II. MOTIVATION BEHIND THIS STUDY

According to the World Health Organization (WHO) report, nearly 1.35 million people died in road accidents, making road traffic injuries the eight leading cause of death globally [20]. The number of fatalities associated with road accidents is extremely high, thus, measures must be taken to improve road safety. Most injuries incurred by accidents are not serious, and the victim's life can be saved if rescued timely. However, it takes additional delay to manually notify the emergency teams due to poor communication mechanisms, thus, victims are left unattended for a long time, resulting in an increased death rate.

The consequences of road accidents are not just constrained to the loss of human lives yet, also incorporate the destruction of property, traffic blockages, and immense economic loss. Thus automatic accident detection systems are the need of time, which can speed up the rescue operations and limit the casualties after the mishap and numerous lives can be saved. This paper features existing mechanisms to detect accidents, its working, and limitations. Furthermore, accident prevention methodologies, accident contributing factors are highlighted as well. This study critically reviews existing

literature on accident detection and prevention techniques, with the objective that smart systems can be developed with improved accuracy and better strategies to control accident causing factors while watching out for the existing challenges in the current systems.

III. INTERNET OF THINGS CHARACTERISTICS

Internet of Things (IoT) refers to a network of things. These things could be any object that we see in our daily life. These objects are not limited to electronic devices or some high end technology products but could include objects that we won't normally think of them as electronic like dustbins, chairs, clothes etc., [21]. It's a network of smart objects in which the objects are capable of sharing resources and data with other objects. The data collected from the objects is further analyzed to extract the useful information [22]. The smart objects are equipped with some sort of sensors, processing powers and an ability to communicate to other objects. IoT has provided many benefits to improve the quality of life, where smart objects are used to simplify our daily errands [23]. The major characteristics of IoT are as follows:

A. INTER CONNECTIVITY AND SERVICES

As long as IoT is concerned, IoT devices can be inter-linked with the worldwide information and communication foundation [21], [24]. Things-related services such as privacy protection, semantic consistency between physical things and their virtual interlinked items within the constraints of objects are offered by IoT. Technologies continue to develop both in the real world and in the information world to provide things-related services [21], [24].

B. HETEROGENEITY

The IoT devices are heterogeneous in nature. Various devices can communicate with each other due to this property. The devices that make use of different hardware platforms, networks, technologies can communicate with each other due to this feature [21], [24]. IoT system includes connectivity of various devices, platforms and operating systems inter-linked by different protocols [25]. IoT provides connectivity between different devices which have different power constraints, vendors and are designed for different purposes. The goal of IoT is to provide seamless machine to machine, machine to human and human to human connectivity, so it must be able to connect different things and networks [26].

C. DYNAMIC CHANGES

The IoT devices are dynamic i.e. rapidly changing in nature. The state of devices varies with time. For example, the devices may be in sleep/wake state, connected/disconnected. The number of devices at a time can also change [21], [24]. Some new devices can be added in the network, while other might leave the network. IoT devices are able to adapt to the changing needs. For instance, security cameras can adapt their modes according to the time of the day [25]. The device's connectivity with other devices may vary during different time intervals such that it's connected

to one set of devices at one instance, and to another set at another instance, so to ensure security, efficient cryptography systems and good security protocols are needed [26].

D. ENORMOUS SCALE

The number of devices that are inter connected and need to be tracked and handled would be at least an order of magnitude greater than the internet devices currently connected. It'll become even more complex to manage the massive amount of data produced by these devices and using this data and it's interpretation for different application purposes [21], [24].

E. SAFETY

While we avail numerous benefits from IoT, an important concern 'safety' should also be considered. Whether we are creators or receivers of IoT, we must ensure safety. It includes the safety of our physical well-being as well as our private data. This also includes ensuring the safety of communication endpoints, networks, data being communicated across the paths, thus creating a security standard that will be able to scale [21], [24].

F. CONNECTIVITY

Connectivity entitles attainability and compatibility. Network availability refers to be able to receive on the network and compatibility refers to be able to use and produce data [21], [24]. New possibilities for IoT can be generated by bringing together the routine objects and connecting the smart gadgets and applications [25].

IV. IoT APPLICATIONS

IoT has numerous and diverse applications which cover almost all areas in our day to day tasks. It covers many domains such as transportation, agriculture, healthcare, waste management, supply chain, environment and energy as shown in Figure 2. Some of the applications of IoT are as follows:

A. IoT IN HEALTHCARE

IoT has numerous applications in healthcare. It can be used to monitor and indicate various health indicators.

Patient Monitoring – Patients can be monitored for various conditions like heart rate, blood pressure, glucose level etc. inside hospitals.

Medical Cold Storage – Various medicines, vaccines could be stored and their conditions can be monitored, like when they'll expire etc.

Fall Detection – Assistance could be provided for elderly or handicapped people if they fall, timely assistance could be provided to them.

Dental – Toothbrush connected by means of Bluetooth to a Smartphone app can analyze brushing habits.

Physical Activity Monitoring – Sensors placed on some gadget like watch, that a person could wear, it can monitor how many steps he walked, heart rate etc., [21], [22], [24], [27].

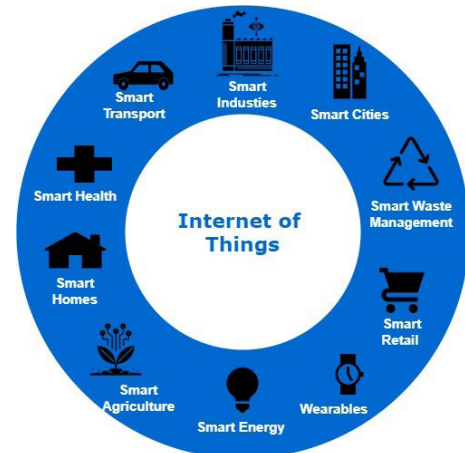

FIGURE 2. IoT applications.

B. IoT IN SMART ENVIRONMENT

Weather monitoring – Climate changes such as humidity, pressure, temperature and rain can be monitored.

Water Quality Monitoring – Quality of water can be monitored, that is, whether it's safe for humans to consume it.

Prevention of Natural Disasters – River levels could be monitored for early flood detection, similarly land slides and other natural disasters could be predicted.

Air Quality Monitoring – Quality of air can be monitored and measures could be taken to control the emission of CO₂ and other toxic gases by vehicles, factories and industries.

Forest Fire Detection – Different fire conditions such as combustion gases can be monitored to generate an early alert.

Protecting Wildlife – Wild animals can be traced and their location can be determined through tracking collars, which use GPS to track location and GSM for communication [21], [22], [24], [27].

C. ROLE OF IoT IN INDUSTRIES

Explosive and Dangerous Gases – IoT can be utilized to detect gas leakages in manufacturing areas, in the vicinity of chemical plants and indoor mines. Harmful gases and oxygen levels in chemical plants can be monitored and controlled to ensure safety for both workers and products [21].

Water, Oil and Gas levels Monitoring – The levels of oxygen, water and oil can be monitored in storage tanks and containers.

Maintenance and Repair – Early predictions can be made for component malfunctions and maintenance service can be set automatically before the actual component failure [21].

Managing fleet of cars – The fleet of cars can be monitored for any corporation. It can monitor it's performance and can process the data to choose the one that needs maintenance [27].

Temperature Monitoring – The temperature inside industries, mines and other work places can be monitored to generate an alert, if the temperature exceeds to ensure the overall safety of workers and workplace.

Ozone Detection – The presence of ozone levels could be detected in food industries during the process of drying meat.

Indoor Air Quality Surveillance – The quality of air can be monitored inside workplaces to ensure general safety of workers and goods [28].

Rescue Operations – Factory workers who may have been stuck in underground units due to natural disasters such as earthquake, land slides, explosion or some other natural calamity may be saved, thorough deployment of IoT resources that can accurately track their location [29].

D. IoT IN AGRICULTURE

IoT has vast applications in agriculture, some of them are as follows:

Green House Monitoring – The climate conditions can be monitored and controlled for green house to maximize the production of vegetables and fruits, and their quality can also be monitored by providing favorable environmental conditions.

Animal Tracking – Animals grazing in open fields and pastures can be identified and located.

Air Quality Monitoring – The quality of air can be monitored to detect any harmful or toxic gases that may emit from waste material [21].

Field Monitoring – The condition of fields can be monitored via different sensors, the data can then be processed, and the farmer could be informed that a particular piece of land requires special care.

Pest Control – Different mechanisms can be incorporated to control the pests in crops, to ensure quality of crops [27].

Water Management – The water can be managed efficiently to minimize water wastage by making use of different sensors.

Soil Management – The condition of soil can be monitored such as measuring the PH levels, salinity, moisture content etc. so that the farmer sow the seeds according to the soil level.

RFID tags and Sensors – Using RFID (Radio-Frequency Identification) tags and sensors will help identifying and recognizing the diseases that occurred in plants or crops. The farmer can access the information from a remote location and can take the necessary actions, to save the crops [30].

E. IoT IN AUTOMOTIVE INDUSTRY

Vehicle maintenance – The on board units installed on cars can provide diagnosis of the car condition and can help the driver to find faults in the engine or some other parts. The safety measures could also be ensured, like seat belt check, drowsiness detection, over speeding etc.

Vehicle Tracking – The locations of vehicles can be tracked easily by simply installing IoT based trackers on the vehicles.

Entertainment with Connected cars – The connected cars become a center of Infotainment. It creates a pleasant experience for the user. The apps on dash board can provide updates on traffic conditions, information about the current

trip, latest games and internet add the fun element to the trip [31].

Collision Detection – In case of a vehicular mishap or accident, vibration sensors installed in the cars can detect the accident. The information can then be communicated to provide aid to the victims.

Fire detection – The fire sensors installed in the vehicles can be used to detect the presence of flame or fire. On detection of fire the fire rescue system could be triggered or concerned authorities can be notified.

Automated toll and fine payments – Every vehicle will have an RFID tag and on every toll booth, the sensors will scan the car and a predefined amount will be deducted from the owner's bank account associated with that automobile [32].

Driving Insights – Different sensors like accelerometer, Gyroscope, GPS etc. can be used to analyze the driving patterns of the driver.

Geo Fencing and Speed Monitoring – The system could indicate the driver if he has gone out of the bounds of predefined geographical area or is over speeding by comparing it with the predefined threshold limit.

Driver Identification – Bio metrics can be used to authenticate the driver. Bio metrics may include, fingerprints, face recognition or voice. The driver voice could also be used to provide voice commands to the navigation systems. Bio metric data can also be used for anti-theft protection to ensure maximum security [33].

V. IoT CHALLENGES

IoT improves the quality of our life, due to its numerous applications. However due to its security and privacy issues, it's likely that it'll be less adopted by the users [34]. IoT has vast uses and benefits in different sectors and solves many problems, but still it has various challenges and limitations. One of the main challenge faced by IoT is maintaining privacy and security of users's data [35], [36]. IoT is a large scale network, which includes many manufacturers, industries, and it may vary in different applications according to the user's need. Such large scale deployment of service, needs to be in the boundaries of a certain standard. IoT will be developed in a step by step procedure. Various challenges faced by IoT need to be addressed [37]. These challenges may include power consumption, architecture challenge, heterogeneity, mobility, interoperability etc., [35]–[37]. Some of the challenges of IoT are discussed below:

A. MOBILITY

One of the major issue to implement IoT is mobility, because IoT is expected to offer services to the mobile users as well. It continuously needs to connect the users, in order to provide better services. It is unable to provide the services to the mobile users when it needs to transfer from one gate to another [35]. Mobility is one of the prominent characteristic of IoT devices, thus the devices need to join the nearby networks without any previous configuration. Thus, good

security mechanisms need to be implemented to make the IoT devices compatible with mobility [36].

B. POWER CONSUMPTION

Power drainage of devices is one important challenge in IoT. IoT is concerned with how it can interlink things in a compatible fashion, while watching out for the energy constraints because communication is one of the most power consuming task [21]. Computing is involved in every aspect of human lives, so power consumption becomes an unavoidable issue. Some mechanisms should be introduced to have IoT devices which consume less energy. In order to use the IoT devices, it's need of time that problem of storing power in devices should be solved [38]. The energy capacity of IoT devices is limited and they have to be replaced after some time, however some devices consume a lot of power and they can't be recharged. Low bandwidth connections should be used, in order to extend the battery life [36].

C. SECURITY AND PRIVACY

To provide and avail services through out the day in an IoT environment, the things and people are connected with each other. However, the communication over internet is prone to security breaches, since the devices are not equipped with good security mechanisms. Different devices are connected with each other and data is shared among them instantly, thus a mechanism is needed to ensure data integrity and confidentiality [39]. The network of IoT not only consists of things, but also crucial data and high value gadgets which further creates hurdles to ensure security. The main issues arise due to implementation through remote clouds which are connected with other interlinked systems, user's personal data etc., [40]. In order to make IoT more usable in real world it's security issues must be solved. The IoT network is estimated to deal with a exponentially growing number of interconnected devices. These objects will exchange information; thus their interactions must be secure to ensure data integrity. The heterogeneous nature of IoT, where different types of devices, located at different places will interact, further makes it complex for the deployment of an efficient and scalable security algorithm [41].

D. INTEROPERABILITY IN HETEROGENEOUS ARCHITECTURE

Interoperability is prominent challenge as far as IoT network is concerned. This is mainly due to heterogeneous nature of the IoT devices which have varying protocols, data formats, platforms etc., [42]. Internet connectivity requires that the connected devices are able to communicate in the language understood by all of them, thus IoT systems need to handle the interoperability issues [21]. IoT platforms connect various devices that may include different sensors, access points etc. Each platform may make use of different formats for availing different services and resources. Therefore, it's quite a challenge to provide services via such diverse platforms [43]. IoT interoperability can be classified into device

interoperability, syntactic interoperability, networking interoperability, semantic interoperability and platform interoperability. Many approaches have been proposed by researchers and industry to handle the interoperability issues, but still these approaches don't cover all aspects of interoperability. The collaboration between different vendors could also help in solving the interoperability issues [42].

VI. PROMINENT IoT TECHNOLOGIES

IoT consists of a large network of interconnected things that communicate and exchange data. IoT is able to transform any real life object into a computing device that can sense and communicate [44]. It consists of a large network of heterogeneous devices consisting different sensors and actuators attached to various daily life objects [45]. IoT has turned the traditional internet where only human to human services were offered into a network where real life objects can communicate and exchange data [46]. Different wireless and wired platforms can be used by the smart devices for communication purpose. Wireless IoT utilizes different wireless protocols for communication [47]. These technologies include LoRaWAN, Near Field Communication (NFC), ZigBee, 6LoWPAN, Bluetooth Low Energy (BLE) and Z-Wave [44], [45], [47]. Some prominent wireless communication protocols used in IoT are discussed below:

A. LPWAN

Low Power Wide Area Network (LPWAN) is a wireless communication technology. The main characteristics of LPWAN technologies are large communication range, long battery life and low cost devices [44]. In the LPWAN technology, there are two categories, namely, Long Range (LoRa) and narrow band (NB-IoT) [48]. Lora is an unlicensed long range low power wireless technology which improves network performance, reduces device cost and supports large number of devices [46]. NB-IoT is a licensed narrowband technology which provides improved performance in terms of range, reliability, QoS (Quality of Service) and latency [49].

B. LoRaWAN

Long Range Wide-Area Network (LoRaWAN) is a Low-Power, Wide-Area Network (LPWAN) which has adequate capacity and communication range with low power consumption and cost [44]. It offers core IoT requirements such as secure communication, mobility etc. It also reduces the complexity involved in communication due to heterogeneous nature of IoT by providing seamless interoperability [45]. It's a wireless communication protocol developed by Lora Alliance [46]. LoRaWAN standard supports two security layers, to ensure application and network security. Device authentication is supported by network layer security, whereas security of application data is ensured by application layer security [44]. LoRaWAN classifies end devices into three categories namely A, B and C. Class A devices are in sleep mode most of the time and are energy efficient. LoRa gateway sends time synchronized beacons to

Class B devices which enables them to open extra receive windows. Class C devices are able to receive data at any time except for the time when data is being transmitted [45]. A typical LoRaWAN network has three types of entities, namely, Gateways (GWs), End Devices (EDs), and Network Server (NS). LoRaWAN proved efficient in typical IoT applications such as smart metering and environmental monitoring [50]. LoRaWAN provides high flexibility, scalability, security and throughput [48].

C. NB-IoT

NB-IoT is a licensed narrowband technology and is time slotted synchronous protocol [49]. It supports low complexity and low throughput Internet of Things. NB-IoT is built using existing LTE (Long Term Evolution) characteristics. Its network architecture is based on LTE network with little modifications to cater the needs of large network of users. NB-IoT requires a minimum bandwidth of 180 kHz to perform [51]. It has four downlink physical layer channels, namely, broadcast channel, synchronization channel, control channel and the data channel [52]. NB-IoT is preferred by applications that require high QoS and low latency [49].

D. BLUETOOTH LOW ENERGY (BLE)

Bluetooth Special Interest Group (SIG) developed Bluetooth Low Energy (BLE) technology in the 4.0 version of the Bluetooth. It's also called Bluetooth Smart. It's energy efficient and has low device costs [44]. It's main characteristics include low energy consumption, easier setup and installation, and supporting star topology [47]. It's protocol stack consists link layer, physical layer and Logical Link Control and Adaptation Protocol (L2CAP). The stack is classified into Controller and Host. The Controller is responsible to implement the link and physical layer, whereas the Host is responsible to implement the upper layers [44]. The low energy consumption feature of BLE makes it a suitable protocol for many applications such as wearables, health monitoring apps, home appliances etc. [45].

E. ZigBee

ZigBee is a wireless communication technology defined by the ZigBee Alliance. It provides seamless interoperability between devices from different vendors. The ZigBee protocol stack is build up on IEEE 802.15.4 standard. To ensure secure communication it provides two types of keys namely, network key and multiple link key. The network key is shared by all the nodes in network, whereas the multiple link key is only shared among the communicating nodes [44]. ZigBee supports different types of topologies like tree, star and mesh network topology. It's suitable for those applications and devices that require low data consumption, good battery life and maximum security [47].

F. NFC

Near Field Communication (NFC) is a short-range communication technology, which operates on electromagnetic fields

at a frequency of 13.56 MHz and a distance of about 10cm. The devices in a NFC network communicate by generating fields [44]. NFC contains a tag which has data that can be read only or the device can rewrite it later on. NFC operates in three modes [47]. NFC technology makes it simpler to exchange digital content, making transactions and connecting electronic gadgets with a simple touch. It's configuration and setup is easier to implement and it does not require line of sight [53].

VII. LITERATURE SURVEY

In this section different techniques for collision detection and reporting are discussed. Most of the systems focused primarily on mechanisms for accident detection, while some systems also focused on taking preventive measures to prevent accidents, so the strategies used to detect and prevent accidents are discussed separately. Figure 3 summarizes the accident detection and prevention techniques discussed in this study.

A. ACCIDENT DETECTION TECHNIQUES

Millions of people die in road accidents every year, most of the time accidents are not serious, but there is still a huge loss of life due to delay of emergency services. So a system capable of analyzing a situation and able to detect it as an accident would be very helpful in providing timely assistance. Various strategies used to detect accidents are discussed in this section.

1) CONVENTIONAL ACCIDENT DETECTION TECHNIQUES

a: USING VANET (VEHICULAR AD-HOC NETWORK)

Manuja et al. [10] proposed that problems of traffic congestion arise due to vehicle failure or due to accidents in no network area. They proposed a system to solve this problem based on VANET. In this system every moving vehicle is considered as a node. The alert messages are transmitted using RF module, and alert messages are received by the moving vehicles that are in the range of RF module. Finally, the vehicle in the network area receives the message, then the received message is transmitted to the base station. The alert message contains four types of messages. These are detected by piezo electric sensor, MEMS (Micro-electro-mechanical systems) sensor, flame sensor, and temperature sensor.

The system identifies vehicular mishap in considerably less time and alerts the rescue teams along with the location of mishap. A switch is also added in the system, which the driver can use to stop sending alert message in case when injuries are minimum or there's no serious loss. The controller gets the input from sensors and sends the accident alert information to the road side unit and then message is sent to the rescue team. WIFI and GPS are used to find the location of vehicle. In previous systems, GSM module failed to communicate in no network area, it'll provide coverage in network and no network area. A switch is also available to stop sending of message in case of no serious damage.

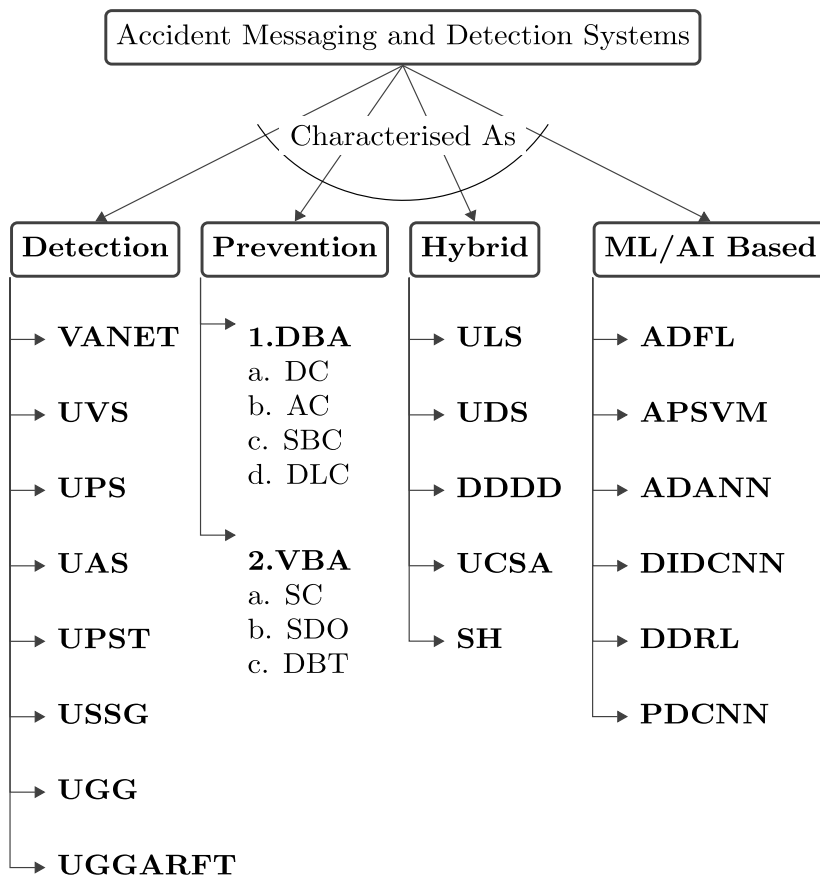

FIGURE 3. A taxonomy of accident detection and prevention techniques.

However, the major limitations that could be addressed in the future are VANETs have security and privacy issues, also they have highly dynamic topology due to which routing issues may arise.

Shabir *et al.* [54] presented a survey of different congestion control techniques for VANETs. To address the network congestion issue in VANETs three different approaches are discussed which are proactive, reactive and hybrid congestion control strategies. To address network congestion, latency and throughput are two important parameters. The techniques are categorized in six major categories which include rate-based, power based, hybrid strategies, CSMA/CA (Carrier Sense Multiple Access with Collision Avoidance) based, prioritizing and clustering-based strategies. The discussions show that proactive techniques are best to control congestion in VANETs since they proactively handle the congestion in network, moreover priority based approaches also show better performance if they are used along with hybrid congestion control techniques.

In [55] its discussed that network congestion is a severe issue in VANETs, since VANETs have highly dynamic topology. Congestion in VANETs can really affect the performance of applications using them, especially emergency

services like rescue teams, ambulances who need to communicate timely in case of emergency situations like road accidents, mishaps, security alerts etc. The main applications of VANETs include safety and non-safety applications. The safety applications can reduce the chance of accidents by providing early warnings to the vehicles. Time criticality is one of the main concern in safety applications, however the congestion in network can degrade it's performance.

A VANET is a type of MANET (Mobile ad hoc network) which considers vehicles as mobile nodes. VANETs can be used in ITS to ensure convenience and road safety. A typical scenario for reporting emergency situations in a VANET environment is demonstrated in Figure 4. The main issue in VANETs is, it's highly dynamic topology due, to which different problems like network congestion, frequent disconnections etc. may arise. To address these issues, multicast routing techniques can be used in VANET protocols. Different VANET multicast routing protocols are reviewed in this study. The performance of routing protocols is analyzed based on the routing techniques used by the protocols. The multicast routing techniques are classified as proactive, reactive and flooding techniques. The goal behind development of multicast routing methods in VANETs is to address issues like

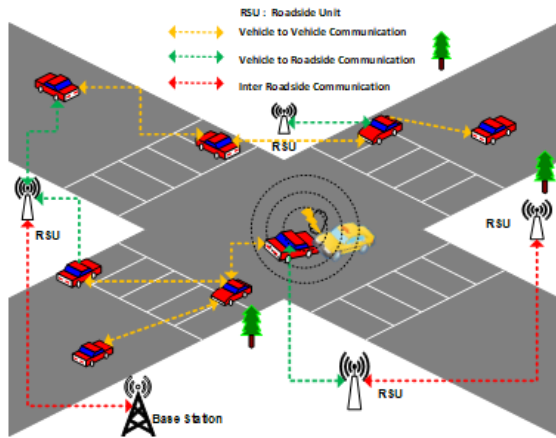

FIGURE 4. Accident reporting scenario in VANET.

network overhead, avoiding loops and adaptability in highly dynamic topology. The VANET multicast routing protocols are categorized into geocast and cluster-based routing. The multicast routing protocols for VANETs are compared on various parameters such as real time, location based, map based and spatiotemporal. The study shows that use of multicasting in VANET routing protocols reduces fragmentation, power consumption and transmission overhead. The setup for multicast routing protocol for VANET may vary according to different environments, hence a single protocol may not be suitable for every type of VANET environment, because the design may change according to the needs and functionality of that particular environment.

b: USING VIBRATION SENSORS

Tushara and Vardhini [56] proposed a solution for accident detection that uses a micro controller to control operations like detecting and reporting. The system focuses on minimizing the action time after an accident has occurred. A number is pre-fetched on the system, to which an alert is sent on occurrence of accident. The accident is detected using a vibration sensor. The system has high probability of generating wrong output because of its reliance on single sensor only. The weakness of the system is that it generates an alert message on occurrence of accident but accident location is not shared.

c: USING PIEZOELECTRIC SENSORS

Patil et al. [57] put forward a solution in which the system will sense accidents and will inform the nearest police station and rescue teams. GSM technology is used to communicate alert messages to the emergency services. The system continuously tracks the vehicle and can immediately alert the emergency services in case of any mishap. Renessa's microcontroller is used in conjunction with GSM modem and GPS receiver. GSM is used for communication purpose which sends an alert message containing the location which is provided by GPS. It's main modules consist of piezoelectric sensor, GSM and GPS. The system tracks the location

continuously so in case of mishap the location is communicated timely. The primary drawback of this approach is that, no switch is available to cancel sending of alert messages in case of no serious damage, secondly location is continuously monitored, so it might drain a lot of battery.

d: USING ACCELEROMETER SENSORS

In [4] its discussed that, "one fourth of the people involved in accidents are motorcyclists". Rash and careless driving are the primary causes of casualties in bike riders. A system is proposed which uses helmet as an apparatus for accident detection and reporting. Sensors, processors and cloud computing infrastructure are used to build the system. On accident detection details are sent to the emergency contacts using Cloud based service. GPS tracks the location of vehicle. A GPS, microcontroller and an tri-axial accelerometer are present on the helmet. The probability of accident is calculated by continuously monitoring orientation of head and helmet's position. If the pre-fetched speed limit is exceeded, a text message as an alert is sent to the emergency contacts. The system on the helmet connects with the cloud server using RESTful architecture communicating through HTTP (HyperText Transfer Protocol). The system is cost effective as compared to other systems, also on occurrence of accident, text messages are repeatedly initiated until acknowledged. The major drawback of this approach is that there is a possibility of false alarm if the driver drops the helmet by mistake, additionally, more storage and computational capabilities are needed because the system needs to communicate with the cloud services.

Anil et al. [58] presented a solution for collision detection. The system detects the accident using flex and accelerometer sensors and the location of accident is communicated via GSM modem to the emergency services. Alert message contains information about location, vehicle number and time of accident occurrence. The current situation of passengers is monitored through real time video transferred by the in mounted camera. Accelerometer monitors speed of vehicle. Sensor's output is compared with the pre-fetched value and if it exceeds the defined threshold value, it indicates the occurrence of accident. The camera on the receiver module is connected with a screen, on which live situation of vehicle can be seen. The major advantage of this approach is that the accident severity could be known and medical aid could be provided accordingly due to in mounted cameras in the vehicle. However, this also has privacy concerns due to live video feed transmission.

Megalingam et al. [59] proposed a solution to smartly detect vehicle collision and alert the rescue teams. The system can be placed inside a vehicle in which an accelerometer sensor detects an accident, this output of sensor is monitored by a microcontroller. The RF (Radio Frequency) transmitter module is interfaced with the microcontroller which transmits the information to the emergency services. The RF receiver module at the emergency service will receive this information. The emergency services on receiving the information

would take appropriate actions to provide timely medical aid. The major drawback of this approach is that RF module has limited range, moreover it relies only on one sensor, so it has single point of failure.

e: USING PRESSURE SENSOR, TILT ANGLE

In [12] a solution based on android application for accident detection and reporting is presented. Outward force experienced by the vehicle is monitored by means of an external pressure sensor, speed and tilt angles are measured by GPS and accelerometer sensors of the phone. Bluetooth on the phone receives the data from sensors. As accident occurs the speed of vehicle decreases abruptly. So an accident will be detected if vehicle speed changes abruptly and values of pressure and tilt angle exceed the pre-fetched threshold limit. A switch which the driver can use to stop sending of alert message in case when the accident isn't severe or in case of false alarm is also present. A smartphone based accident detection system is demonstrated in Figure 5. However, the research is subject to some limitations such as magnitude of force experienced by the smartphone would not be the same as of the magnitude of force experienced by the vehicle, moreover smartphones have battery constraints.

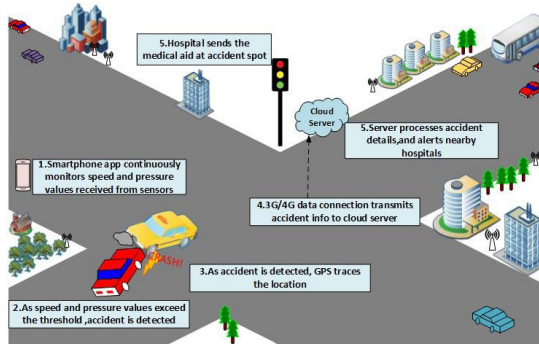

FIGURE 5. Smartphone based accident detection system.

f: USING GYROSCOPE, GPS, ANDROID APP AND RF TRANSMITTER

Kumar and Deepak [60] proposed a solution for accident detection and reporting which requires no manual interaction of human before or after the occurrence of accident. Its main module consists of GPS, Raspberry Pi, android application and Gyroscope. The system also stores the blood group of the driver. As soon as the vehicle meets an accident, the gyro which is placed in the vehicle measures the rotation angle and if it exceeds the threshold limit, it will send an alert to the active server. The app is placed in the ambulance which continuously receives the information from server, the app helps the ambulance to navigate to the accident spot using the route which has less traffic by using Google maps API (Application Programming Interface). To avoid traffic congestion, the ambulance transmits RF signal time to time, the RF receiver is present in the traffic lights. When the traffic

lights sense RF signal, they turn green to allow the ambulance reach the accident spot as fast as it could. The emergency message is also sent to the victim's family.

g: USING SHOCK SENSORS, GPS

Nasr *et al.* [61] presented a solution in which the system informs the PSO (Public Safety Organization) on occurrence of accident. Shock Sensor detects occurrence of accident, the signal is processed and then sends the geographic location to PSO. The system has different phases which are as follows:

- (a) Registration of vehicle
- (b) Registration of passenger
- (c) Accident monitoring through PSO headquarters

In Vehicle Registration phase, the person's vehicle is registered. An IoT device is installed on the system. After installation of device, the person gives the vehicle ID to the person who's responsible for registration of vehicles in the PSO headquarters' database. Its main modules consist of NFC reader, shock sensor, GPS, and cellular IoT. These modules communicate with each other to identify an accident and report it to the PSO headquarters with the exact location of accident. As the shock sensor detects accident, an alert through HTTP request is sent along with the location.

h: USING GPS, GSM

In [5] a system is proposed, that considers the speed as one of the major cause of accident. It uses a GPS receiver to monitor the speed and detects an accident based on monitored speed. The GPS module continuously monitors the speed and compares with the previously monitored speed every second using a micro-controller unit.

Whenever the system identifies that the speed is less than the pre-fetched threshold limit it will detect the situation as an accident. The location is detected by using a GPS module. An alert message is sent to the emergency services using a GSM module. Figure 6 illustrates a GPS/GSM based accident detection system. The problem of the system is that it relies only on a single sensor for accident detection which has high chance of generating false positives.

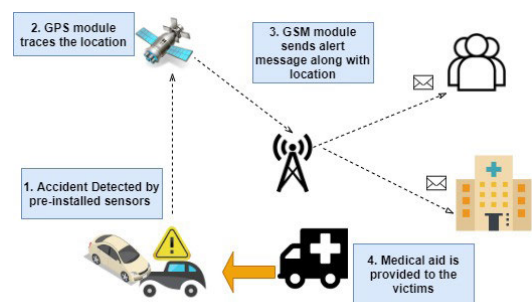

FIGURE 6. An accident detection system using GPS and GSM.

In [62] a solution to find the position of vehicle based on ARM micro controller is presented. To get the position of vehicle, the intended person initiates a request via SMS.

The request is received by the GSM module and is acknowledged. The request is then processed by the Spartan processor. The processor sends the command to GPS module of the system. The GPS module tracks the location of vehicle and replies the request with location coordinates of the vehicle. Vehicle's location is sent to the user with longitude and latitude's values. The weakness in the literature lies in the fact that external environmental factors can have greater impact on the performance of system.

2) ML/AI BASED ACCIDENT DETECTION TECHNIQUES

Transportation system plays an important role in human life; however, where it provides many facilities, it has many risks associated with it as well [63]. The road traffic accidents are increasing every year, so an effective mechanism is needed to minimize its frequency [16]. Crash prediction models have been very famous to ensure road safety particularly on highways [64]. Different models have been presented for crash prediction in the domain of Machine Learning (ML) and Artificial Intelligence (AI), namely, Artificial Neural Networks (ANN) [65], Support Vector Machine (SVM) [64], [66], fuzzy logic [19], [63], Genetic Programming [67], Random Forest Classifiers [16] etc. The real time data is fetched in the models and is compared with the previously collected accident data, which helps in differentiating a normal situation from an accident [17]. The key approaches for accident prediction in the ML/AI domain are discussed below:

a: ACCIDENT DETECTION USING FUZZY LOGIC

Alkandari *et al.* [19] proposed a solution to detect accidents in range of traffic lights using fuzzy logic technique which detects accidents. The system consists of two sub systems namely, Detection System and Action System. The system is based on Webster Method with a little variation. The system collects data about different zones including number of cars in a lane, speed of cars in particular lanes etc. The disturbance in normal traffic flow is the main indicator that an accident has occurred. The main elements of the system are crisp inputs/outputs, membership functions, fuzzy rules and linguistic variables. The linguistic variables which are, cross ratio, zone status, accident status and section speed help in determining a situation as an accident. The output of the system is generated by applying the fuzzy rules to the linguistic inputs, depending upon the input and rules a suitable action would be taken to improve the traffic flow. The results show that the system is able to identify most of the accident scenarios with good accuracy.

In [63] an accident prediction model using fuzzy logic is presented. The relation between accidents and the factors contributing it are non-linear thus using fuzzy logic is a preferable choice for non-linear relationships. Many factors like traffic conditions, human negligence etc. contribute towards road accidents. The major inputs to the model are number of vehicles passing in a lane, speed, road width and road surface condition. Accident data used in the model was

obtained from the authorities, for the road that had increasing accidents in the past years, to improve the accuracy of the model. The model maps the crisp inputs to corresponding crisp outputs using fuzzy rules based on conditions. Every input variable is defined by the membership functions. In fuzzification process the fuzzy variables are constructed by deriving membership function for inputs and outputs and linguistic representation of these membership functions. Triangular and trapezoidal functions are used in this model. The results of the model show good accuracy in predicting accidents. The factors like road lighting and weather conditions were ignored in this study.

b: ACCIDENT PREDICTION USING SUPPORT VECTOR MACHINE (SVM)

B. Pan and H. Wu [66] proposed an approach to detect accidents by means of mobile sensors and SVM. Their approach particularly focused on detecting accidents occurring in urban roads, since they are more prone to accidents, due to involvement of many flow disruptive entities like bus stops, traffic signals etc. as compared to freeways where the traffic flow is not disturbed. This approach uses VANETs in which every vehicle is able to collect its own traffic data like location, identity, speed, lane state with the help of mounted sensors on vehicles. The traffic data is then collected by RSU (Road Side Unit) for further processing which is sent by On Board Units. Three traffic variables are considered to detect accident which are vehicle's speed, acceleration and lane-changing state. Wider range of monitoring can be provided by means of on-board mobile sensors.

c: ACCIDENT DETECTION USING ARTIFICIAL NEURAL NETWORK

In [18] a system is proposed that can detect an accident from the video footage obtained from the CCTV cameras installed on highways. Each frame of video is given as an input to the Convolutional Neural Network (CNN) model, which is able to distinguish frames of video into accident and non-accident. Raspberry Pi 3 B+ Model is used as a remote computer that can be placed on the CCTV cameras. A Pi Camera is used in the system for the purpose of demonstration to obtain the video data. Inception v3 model is used to detect accidents by prior training it, on two different set of video data consisting of accident and non-accident frames. The model is based on CNN which is useful for image classification, object detection etc. The proposed model uses both CNN and Long Short-Term Memory (LSTM) layers. The inception v3 can work on heterogeneous convolutions which enables it to extract more features from the images. The model is implemented on Raspberry Pi by using Tensor Flow, Open CV and Keras. Each video frame is run through the model and then prediction is given whether the frame is accident frame or not. A threshold limit is set and if the prediction limit exceeds 60%, the GSM module is triggered by the Raspberry Pi, which sends an alert message to the nearest hospitals along with the location coordinates. The results show good

accuracy of the system for the trained set of data, moreover the system is also cost effective. The limitation of the study is that, the model was trained for severe accident conditions data, thus the model may not cover all the accident scenarios where accident may be moderate or minor.

B. ACCIDENT PREVENTION TECHNIQUES

Accident prevention can be defined as the strategy or an approach, or actions taken to avoid or stop an accident before it occurs. Majority of the accidents occur due to human negligence. These factors are over speeding, traffic law violations, drunk driving etc. So controlling these factors can help to avoid accidents and save the precious lives. Different approaches used to prevent accidents are discussed in this section.

1) CONVENTIONAL ACCIDENT PREVENTION TECHNIQUES

a: DRIVER DROWSINESS CHECK

Eduku et al. [68] presented a solution to prevent traffic hazards by proposing a system which uses eye blink sensor and automatic braking system to slow down the car and bring it in the state of halt, if drowsiness is detected in driver. A RF module routs the information to the nearby vehicles to alert them that a halt car is there. IR sensors are used to monitor the eye blink and detect the state of drowsiness. Infra-red rays are transmitted to the eyes by means of a IR transmitter, the IR receiver on the other hand receives the reflected rays from the eye. If the output of IR receiver tends to be high, it implies that the eyes are closed. Thus the drowsiness is detected by means of monitoring this high/low output. Its main modules consist of an alarm that warns the driver if drowsiness is detected, automatic breaking systems to slow down the car, and bring it to halt state and RF module to send alert messages to the nearby vehicles in range. The main limitation of the system is that the range of RF module is low.

b: USING ALCOHOL SENSORS, GPS, GSM

Rao and Yellu [3] proposed a system to prevent accidents using alcohol sensors to prevent drunken driving, since 70% of the cases of accidents are due to “drunk and drive”. An alcohol sensor placed in the system, is used to monitor the contents of alcohol in blood. A workflow of such a system is illustrated in Figure 7. Sensor is placed above the steering so that, as the driver breathes the sensor could determine the alcohol level. A threshold is set and if the contents are more than the pre fetched limit, the car doesn’t move. GPS detects the location of the vehicle. Messages are sent by means of GSM to the pre-fetched mobile numbers and inform them that the person is highly intoxicated and can’t drive. The system focuses on the preventive measures to avoid any hazardous situation. The system would be helpful to public in general as well, since it won’t allow drunk person to drive. However, its main limitation is that there could be a false alarm in case when the person sitting next to driver is drunk but the driver

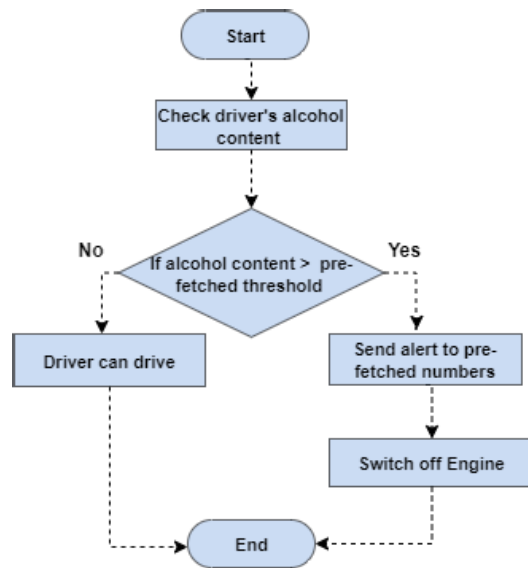

FIGURE 7. Workflow of alcohol sensor based systems to prevent drunk driving.

is not drunk, moreover external interference of air can also affect the performance of alcohol sensor.

c: MAINTAINING SAFE DISTANCE USING ULTRASONIC SENSORS

Kasera [69] presented a system to prevent accidents while driving in hilly areas. Since the roads on the hilly areas are very steep and curvy. To implement this mechanism, the system uses ultrasonic sensors. The system alerts the driver going on one side of the road about the vehicle coming from the opposite direction of the road. The ultrasonic sensors are placed along one side of the road before curve and a LED light after the curve, so if the vehicle comes from one end of the curve the sensor will detect it and LED light lights up on the opposite side of the road. Two ultrasonic sensors and two LED lights are installed on both sides of the curve. As soon as the vehicle reaches one end of the curve, the RED light on the opposite side will automatically light up and will remain on, unless and until the sensor on the other side of the curve detects it. It’s a low power consumption system, moreover its implementation is very cost effective.

2) ML/AI BASED ACCIDENT PREVENTION TECHNIQUES

a: DRIVER DISTRACTION IDENTIFICATION WITH DEEP CONVOLUTIONAL NEURAL NETWORK (CNN)

In [70] it’s discussed that, distracted driving is leading cause of road collisions. Distracted driving can be any activity which makes the driver lose his attention and focus while driving. Some of these activities include talking on phone, texting, adjusting the radio etc. The proposed technique identifies distracted driving using CNN. Driver distraction can be classified into different categories namely, visual, manual and cognitive. Multiple types of distraction can exist together in an activity. Distracted drivers can be identified using

various measures, this technique particularly focuses on using visual data to identify distracted driver. A camera is installed inside the car cabin to identify the driver's behavior. Deep learning model is used to classify distracted driving from normal driving. In this study, a comparison of pre-trained deep CNN is presented. The data set is divided into 10 distinct classes to identify different distraction behaviors like texting, drinking, talking to other passenger etc. The comparison shows that VGG16 with S2 shows good performance in terms of accuracy. The models were pre-trained on the Image net data set, and then retrained on State Farm data set to identify distracted driving behaviours.

b: DRIVER DROWSINESS DETECTION USING REPRESENTATION LEARNING

Dwivedi *et al.* [71] proposed a methodology to detect drowsy state of a driver using representation learning to prevent accidents caused by sleep. The model extracts the visual features from the data, the features are learnt by using CNN. The input image is combined with the learned weights to produce feature maps. A soft-max classifier layer uses these set of features to classify the frames into drowsy and non-drowsy. The facial features are derived using CNN based representation learning technique by which the complex relationships of raw data can be represented by combining features of features. The model consists of two convolutional layers along with a hidden layer of sigmoid function which is linked with regression layer for classification purpose. The frames are extracted from the video and are fed to a face detector. The detected faces are then cropped to square images and then the images are normalized, which are then fed to a convolutional neural network. The classifier shows good performance on diverse data set. The major advantage of the approach is that, representation learning can capture more intelligent features from raw input data as compared to manual methods.

c: PEDESTRIAN DETECTION WITH CNN

A considerable amount of pedestrians die every year in road crashes. Szarvas *et al.* [72] proposed the use of CNN as a classifier in a pedestrian detection system, to identify the pedestrians that could help in reducing the number of accidents. The algorithm is tested on pedestrians in an urban environment. CNN classifier is compared with the SVM (Support Vector Machine) classifier and results show that CNN wins over SVM in terms of accuracy using classic image features. The candidates' images are given as an input to the classifier. A classification score is given to each candidate by the CNN, candidates with higher scores than the threshold are saved in the raw detection list. The list is then sorted by classification scores.

Multiple detection merging operation is used to remove redundant results for the same pedestrian. The evaluation data set consists of positive samples (pedestrians) and negative samples (background) obtained from the camera mounted on the top of car. In order to consider variety of lighting conditions, the data set was equally distributed in different

time zones namely, morning, noon, and evening time. After the merging algorithm terminates, final detection list contains the final results of the detection system. If the height and position are within the margin of tolerance, the result was considered correct. This approach achieves high accuracy through automatic optimization of the features and regularization of neural network. The accuracy of the classifier is improved by using Haar wavelet features.

C. HYBRID TECHNIQUES

Road collisions are one of the leading cause of fatalities. In most cases, injuries are not serious and if victims are rescued in time, lives may be saved. Many factors contribute to accidents, including driver negligence, drowsy and drunk driving etc. Thus a system that can detect as well as controls the factors contributing to accidents will be helpful in preventing accidents and saving lives. Hybrid techniques are techniques which use both accident detection and prevention mechanisms, as shown in Figure 8. Some of the systems based on hybrid techniques are discussed below.

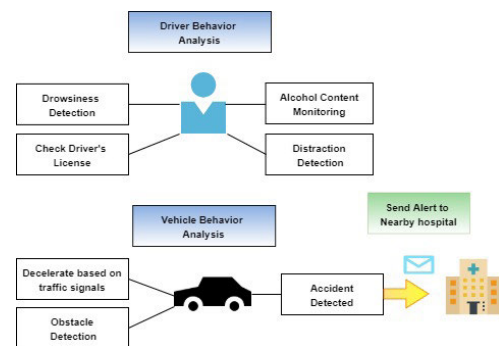

FIGURE 8. An accident detection and prevention system.

1) USING LIMIT SWITCHES

Berade *et al.* [11] put forward a solution for vehicular mishap detection by means of GPS to determine the mishap location and GSM to communicate the information to the pre-fetched number. Additionally, the system also identifies if the driver isn't wearing seat belt or if he is intoxicated. The sensor detects the accident and then PIC (Programmable Interface Controllers) microcontrollers send signals to GPS, GPS tracks the location and then the alert message is sent through GPS module. Limit switches are used for accident detection. Seat belt test will ensure that the driver is wearing seat belt and alcohol sensor placed on steering will check if driver is drunk. The accident is detected via limit switches placed at the back and front of the car. A LCD screen displays messages, in case of seat belt is not worn, or if driver has consumed alcohol, LCD screen gives warnings. System not only focuses on accident detection but also on its prevention by introducing seat belt and alcohol sensors. The use of PIC micro controllers in this system is very effective since they consume very less power as compared to other micro

controllers and are also very fast. The findings of this study have to be seen in light of some limitations, as no switch is included to cut off the signal to the rescue teams in case the driver is safe.

2) DROWSY AND DRUNK DRIVING DETECTION

Nanda *et al.* [2] presented a system which detects accidents by means of vibration sensors. The solution kept in mind the needs of bike riders as they are more prone to serious harm as bikes aren't equipped with preventive measures as compared to other vehicles. GPS tracks the location and for communication purpose GSM is used. The system also has a mechanism for checking if the driver is sleepy. The system also checks if the rider has driving license. The system also makes sure that the driver hasn't consumed alcohol. The camera placed on the front of bike monitors the traffic signals and automatically lessens the speed. It makes use of many measures like traffic signal detection, checking driver license and checking the state of driver to prevent accidents. The system not only detects but also focuses on preventive measures to avoid accidents thus, saving precious lives. The major limitation of this approach is, an inexperienced person can use another person's license to drive, since the system does not authenticate if the license belongs to the person driving.

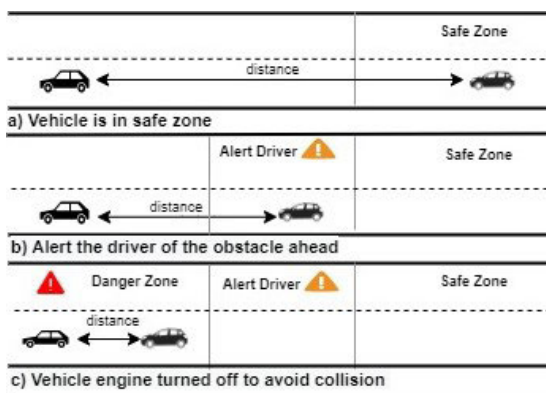

FIGURE 9. Obstacle distance based collision prevention system.

3) USING DISTANCE SENSORS

In [73] a system is proposed that always monitors the distance between vehicles and obstacles that are in front, using distance sensors. A system maintaining safe distance from obstacles is demonstrated in Figure 9. The proposed system alerts the driver to control the speed and reduce the speed by itself when a critical distance comes. Whenever an accident takes place for uncertain condition, an email alert will be sent to the accountable individual with car details. The system automatically controls the speed in case when critical point is reached. Vehicle's distance is measured by ultrasonic sensors. The system makes use of Raspberry Pi, Ultrasonic Sensor, Led Buzzer and Servo motor. On occurrence of accident the alert message is sent using Raspberry Pi. It prevents accidents

by controlling speed when a critical point is reached. Email alerts are sent in case of accident, which are slow means of communication, and providing medical aid could take time.

4) USING CELL PHONE, SPEED AND ACCELEROMETER SENSORS

Ahmed and Jawarkar [13] presented a solution for accident detection and prevention. A system based on microcontroller and an accelerometer sensor along with a recycled cell phone. The system warns the user in case of unsafe driving and sends alerts in case of abnormal conditions of engine temperature or accelerometer. It also has a feature to capture image after accident occurrence and send the multimedia messages to pre-fetched numbers. Its main components include speed sensor, accelerometer sensor, cell phone interface, temperature sensor and Real Time Calendar (RTC) chip. It's environment friendly since junk cell phones are recycled. It can be easily implemented on existing vehicles. The major limitation of this approach is that on occurrence of accidents, alert messages have to be sent manually by the user.

5) SMART HELMET

In [14] a system is presented, which uses smart helmet as an apparatus for accident detection and prevention. The system won't allow the rider to drive unless and until he wears a helmet. The pressure sensor and accelerometer sensor are used to check if helmet is worn by the rider or not. The alcohol sensors placed on the helmet check the alcohol content in the drivers breathe. If the contents are more than the pre-defined threshold limit, the bike won't start, thus preventing drunken driving. On occurrence of crash the helmet worn by the rider will hit the ground, the sensors will detect the motion and tilts of helmet, and will immediately send the site of crash to the emergency contact numbers and rescue teams. The system would be very helpful to the driver as well as the general public, since drunk driving not only risks the life of driver but also affects the safety of other people driving on the roads.

VIII. COMPARATIVE ANALYSIS

In this section, various systems discussed in the literature survey are compared according to the parameters defined in Table 1. The systems are compared in terms of accuracy, their implementation cost to incorporate them in existing vehicles, what's their communication mechanism to send alert messages to the rescue and emergency teams, are the messages sent automatically on detection of an accident or they have to be sent manually by the user etc. Since no system is perfectly accurate, there's always a chance of error in any system, so the systems are also compared against their chance of generating a false positive, i.e. triggering of alarm in non-accident circumstances.

Moreover, in some cases, the accident severity may not be serious and the driver may not need immediate medical aid, so in those cases a mechanism should be there to stop the

TABLE 1. Comparative analysis.

Techniques	FPR	Cost	CM	Acc	AR	STF
Nanda et al. [2]	L	H	GSM	M	Y	N
Rao et al. [3]	H	M	GSM	L	Y	N
Chandran et al. [4]	M	H	MC	M	Y	N
Amin et al. [5]	H	M	GSM	L	Y	N/A
Manuja M et al. [10]	L	H	GSM	H	Y	Y
Berade et al. [11]	L	M	GSM	M	Y	N
Faiz et al. [12]	H	M	GSM	M	Y	Y
Ahmed et al. [13]	H	L	GSM	L	N	N
Priyanka C et al. [14]	H	M	GSM	L	Y	N
Ghosh et al. [18]	L	H	GSM	H	Y	N/A
Alkandari et al. [19]	L	M	N/A	H	N/A	N/A
Tushara et al. [56]	H	L	GSM	L	Y	N
Patil et al. [57]	H	M	GSM	L	Y	N
Anil et al. [58]	M	M	GSM	M	Y	N
Megalingam et al. [59]	H	L	RF	L	Y	N
Kumar and Deepak [60]	L	H	GSM	H	Y	N
Nasr et al. [61]	H	M	GSM	L	Y	N
Wen and Meng [62]	N/A	M	GSM	M	N/A	N/A
Gaber et al. [63]	M	M	N/A	M	N/A	N/A
Pan and Wu [66]	M	H	RF	M	N/A	N/A
Eduku et al. [68]	L	M	RF	H	Y	N
Kasera et al. [69]	L	L	N/A	M	N/A	N
Basubeit et al. [70]	L	M	N/A	H	N/A	N/A
Dwivedi et al. [71]	M	M	N/A	M	N/A	N/A
Szarvas et al. [72]	L	H	N/A	H	N/A	N/A
Murshed et al. [73]	M	M	RP	M	Y	N

FPR:False Positive Rate
H: High
CM:Communication Mechanism
L: Low
N/A: Not Applicable
Acc:Accuracy
M: Medium
RP:Raspberry Pi
AR:Automatic Reporting
N: No
MC:Micro-controller
STF:Switch to Terminate False alarm
Y:Yes
RF: Radio Frequency

sending of an alert message, to save the time of rescue teams. So the presented systems are also compared if they've the mechanism to stop sending of an alert message or not.

It can be seen from Table.1 that many systems lack accuracy, and may not generate accurate results in every situation. Moreover, many systems did not have a mechanism to stop sending of alert messages in case of false alarm.

Most of the systems presented in the literature survey, relied on some sort of hardware based technologies like sensors for implementing accident detection and prevention mechanisms. A summary of different type of sensors such as alcohol, seat belt, vibration, pressure etc. used in these systems, for accident detection and prevention is presented in Table 2. It's quiet evident from the analysis that, most of the systems use GPS to detect location of accident, GSM as a communication mechanism to send alert messages and accelerometer and pressure sensors to detect accidents.

IX. RECOMMENDATIONS

Various methods for accident detection and prevention were discussed in this paper. The methods included warning the driver for over-speeding, maintaining safe distance from other vehicles, avoiding intoxicated and distracted driving etc. Integration of these systems with the vehicles would be very beneficial to the society. These systems would be effective in minimizing the casualties associated with road accidents. Additionally, patient history such as blood group, age, allergies etc. can also be included in these systems to provide medical aid accordingly. Moreover, data obtained from sensors after an accident has occurred, can be used in data mining to deduce important results. Performing analysis on the data can give us valuable insights on how most of the road accidents occur, which factors contribute the most in event of mishaps, which roads are dangerous and the time stamp in which most of the accidents occur. The data collected from these systems could also help police to find the crimes of hit and

TABLE 2. Summary of sensor types used for conventional accident detection and prevention techniques.

Techniques	Accel	S	GPS	P	D	V	RFID	SB	LS	AL	Temp	IR
Nanda et al. [2]	✓	×	✓	✓	✓	✓	✓	×	×	✓	×	×
Rao et al. [3]	×	×	✓	×	×	×	×	×	×	✓	×	×
Chandran et al. [4]	✓	×	✓	×	×	×	×	×	×	×	×	×
Amin et al. [5]	×	×	✓	×	×	×	×	×	×	×	×	×
Manuja M et al. [10]	×	×	✓	×	×	✓	×	×	×	×	✓	×
Berade et al. [11]	×	×	✓	×	×	×	×	✓	✓	✓	×	×
Faiz et al. [12]	✓	×	✓	✓	×	×	×	×	×	×	×	×
Ahmed et al. [13]	✓	✓	×	×	×	×	×	×	×	×	✓	×
Priyanka C et al. [14]	✓	×	✓	✓	×	×	×	×	×	✓	×	×
Tushara et al. [56]	×	×	×	×	×	✓	×	×	×	×	×	×
Patil et al. [57]	×	×	✓	✓	×	×	×	×	×	×	×	×
Anil et al. [58]	✓	×	✓	×	×	×	×	×	×	×	×	×
Megalingam et al. [59]	✓	×	×	×	×	×	×	×	×	×	×	×
Kumar and Deepak [60]	×	×	✓	✓	×	×	×	×	×	×	×	×
Nasr et al. [61]	×	×	✓	×	×	×	×	×	×	×	×	×
Wen and Meng [62]	×	×	✓	×	×	×	×	×	×	×	×	×
Eduku et al. [68]	×	×	×	×	×	×	×	×	×	×	×	✓
Kasera [69]	×	×	×	×	✓	×	×	×	×	×	×	×
Murshed et al. [73]	×	×	×	×	✓	×	×	×	×	×	×	×

Accel: Accelerometer S:Speed P:Pressure D:Distance V:Vibration SB:Seat Belt LS:Limit Switches AL: Alcohol Temp:Temperature IR:Infrared

run cases. In addition, the information about occurrence of accidents can be routed to the vehicles in range, to avoid any further mishaps, that can be helpful in reducing chain reaction accidents in which multiple vehicles are involved in the crash, creating a chaotic situation.

X. CONCLUSION AND FUTURE WORK

The number of casualties associated with road collisions is growing rapidly. If victims are rescued in due time, several lives may be saved. We discussed various strategies which focused not only on accident detection but also on its prevention. These strategies utilized various sensors such as accelerometer sensors, shock sensors, pressure sensors etc. and various machine learning techniques such as neural networks, support vector machines, representation learning etc. for accident detection. Various strategies for accident prevention were also addressed, which include detection of drunk and drowsy driver, regulating vehicle speed, maintaining safe distance from obstacles etc. Once the accident is detected, the information is communicated to emergency services to provide timely aid. Such systems provide many advantages such as mitigating road collisions, identifying precise accident locations and facilitating over all rescue operations. The integration of these systems with vehicles would be somehow expensive yet will give various advantages. However, the systems we discussed were all reliant on some kind of hardware or software based technology and there is a possibility

that those sensors or devices can themselves be destroyed in the accident and can generate erroneous readings and results. So such frameworks are required which are less reliant on some kind of hardware or software.

REFERENCES

- [1] F. Bhatti, M. A. Shah, C. Maple, and S. U. Islam, "A novel Internet of Things-enabled accident detection and reporting system for smart city environments," *Sensors*, vol. 19, no. 9, p. 2071, May 2019.
- [2] S. Nanda, H. Joshi, and S. Khairnar, "An IOT based smart system for accident prevention and detection," in *Proc. 4th Int. Conf. Comput. Commun. Control Autom. (ICCCUBEA)*, Aug. 2018, pp. 1–6.
- [3] T. V. N. Rao and K. R. Yellu, "Preventing drunken driving accidents using IoT," *Int. J. Adv. Res. Comput. Sci.*, vol. 8, no. 3, pp. 397–400, 2017.
- [4] S. Chandran, S. Chandrasekar, and N. E. Elizabeth, "Konnect: An Internet of Things(IoT) based smart helmet for accident detection and notification," in *Proc. IEEE Annu. India Conf. (INDICON)*, Dec. 2016, pp. 1–4.
- [5] M. Syedul Amin, J. Jalil, and M. B. I. Reaz, "Accident detection and reporting system using GPS, GPRS and GSM technology," in *Proc. Conf. Informat., Electron. Vis. (ICIEV)*, May 2012, pp. 640–643.
- [6] J. B. Edwards, "The relationship between road accident severity and recorded weather," *J. Saf. Res.*, vol. 29, no. 4, pp. 249–262, Dec. 1998.
- [7] R. N. Nayan Kumar, V. R. Navya, N. Ganashree, K. U. Pranav, and N. Ajay, "Intelligent vehicle accident detection and ambulance rescue system," *Int. J. Advance Res., Ideas Innov. Technol.*, vol. 5, no. 3, pp. 685–687, 2019.
- [8] M. U. Ghazi, M. A. Khan Khattak, B. Shabir, A. W. Malik, and M. S. Ramzan, "Emergency message dissemination in vehicular networks: A review," *IEEE Access*, vol. 8, pp. 38606–38621, 2020.
- [9] W. Farooq, M. Ali Khan, and S. Rehman, "A novel real time framework for cluster based multicast communication in vehicular ad hoc networks," *Int. J. Distrib. Sensor Netw.*, vol. 12, no. 4, Apr. 2016, Art. no. 8064908.
- [10] Manuja M, Kowshika S, Narmatha S, and G. Theresha W, "IoT based automatic accident detection and rescue management in Vanet," *SSRG Int. J. Comput. Sci. Eng.*, pp. 36–41, Feb. 2019.

- [11] P. Berade, K. Patil, P. Tawate, and M. U. Ghewari, "Intelligent accident identification and prevention system using GPS and GSM modem," *Int. Res. J. Eng. Technol.*, vol. 5, no. 2, pp. 1915–1919, 2018.
- [12] A. B. Faiz, A. Imteaj, and M. Chowdhury, "Smart vehicle accident detection and alarming system using a smartphone," in *Proc. Int. Conf. Comput. Inf. Eng. (ICCIIE)*, Rajshahi, Bangladesh, Nov. 2015, pp. 66–69.
- [13] V. Ahmed and N. P. Jawarkar, "Design of low cost versatile microcontroller based system using cell phone for accident detection and prevention," in *Proc. 6th Int. Conf. Emerg. Trends Eng. Technol.*, Nagpur, India, Dec. 2013, pp. 73–77.
- [14] C. Priyanka, P. Darshini C, V. G. Shavi, and S. Begum, "Two-wheeler safety system for accident prevention, detection and reporting," *Int. J. Eng. Comput. Sci.*, vol. 7, no. 03, pp. 23680–23682, Mar. 2018.
- [15] M. Ozbayoglu, G. Kucukayan, and E. Dogdu, "A real-time autonomous highway accident detection model based on big data processing and computational intelligence," in *Proc. IEEE Int. Conf. Big Data (Big Data)*, Dec. 2016, pp. 1807–1813.
- [16] N. Dogru and A. Subasi, "Traffic accident detection using random forest classifier," in *Proc. 15th Learn. Technol. Conf. (LT)*, Feb. 2018, pp. 40–45.
- [17] P. Amrith, E. Umamaheswari, R. U. Anitha, D. Mani, and D. M. Ajay, "Smart detection of vehicle accidents using object identification sensors with artificial intelligent systems," *Int. J. Recent Technol. Eng.*, vol. 7, no. 5, pp. 375–379, 2019.
- [18] S. Ghosh, S. J. Sunny, and R. Roney, "Accident detection using convolutional neural networks," in *Proc. Int. Conf. Data Sci. Commun. (IconDSC)*, Bengaluru, India, Mar. 2019, pp. 1–6.
- [19] A. Alkandari, I. F. Al-Shaikhli, A. Najaa, and M. Aljandal, "Accident detection and action system using fuzzy logic theory," in *Proc. Int. Conf. Fuzzy Theory Its Appl. (iFUZZY)*, Dec. 2013, pp. 385–390.
- [20] *Global Status Report on Road Safety 2018*. Geneva: World Health Organization; 2018. Licence: CC BY-NC-SA 3.0 IGO. Accessed: May 15, 2020. [Online]. Available: <https://www.who.int/publications-detail/global-status-report-on-road-safety-2018>
- [21] K. K. Patel, S. M. Patel, P. G. Scholar, and C. Salazar, "Internet of Things-IOT: Definition, characteristics, architecture, enabling technologies, application & future challenges," *Int. J. Eng. Sci. Comput.*, vol. 6, no. 5, pp. 6122–6131, 2016.
- [22] T. Mufti, N. Sami, and S. S. Sohail, "A review paper on Internet of Things (IoT)," *Indian J. Appl. Res.*, vol. 9, no. 8, pp. 24–25, 2019.
- [23] P. Asghari, A. M. Rahmani, and H. H. S. Javadi, "Internet of Things applications: A systematic review," *Comput. Netw.*, vol. 148, pp. 241–261, Jan. 2019.
- [24] S. Lakshmi Priya, "Exploring the nuances of Internet of Things in health care assisting system," *Int. Res. J. Eng. Technol.*, vol. 6, no. 2, pp. 1776–1780, 2019.
- [25] H. F. Atlam, R. J. Walters, and G. B. Wills, "Internet of Things: State-of-the-art, challenges, applications, and open issues," *Int. J. Intell. Comput. Res.*, vol. 9, no. 3, pp. 928–938, Sep. 2018.
- [26] R. Vignesh and A. Samyudurai, "Security on Internet of Things (IoT) with challenges and countermeasures," *Int. J. Eng. Develop. Res.*, vol. 5, no. 1, pp. 417–423, 2017.
- [27] R. Khan, S. U. Khan, R. Zaheer, and S. Khan, "Future Internet: The Internet of Things architecture, possible applications and key challenges," in *Proc. 10th Int. Conf. Frontiers Inf. Technol.*, Dec. 2012, pp. 257–260.
- [28] V. Sharma and R. Tiwari, "A review paper on 'IOT' & its smart applications," *Int. J. Sci., Eng. Technol. Res.*, vol. 5, no. 2, pp. 472–476, 2016.
- [29] M. A. Khan, M. A. Khan, A. U. Rahman, A. W. Malik, and S. A. Khan, "Exploiting cooperative sensing for accurate target tracking in industrial Internet of Things," *Int. J. Distrib. Sensor Netw.*, vol. 15, no. 12, Dec. 2019, Art. no. 155014771989220.
- [30] V. N. Malavade and P. K. Akulwar, "Role of IoT in agriculture," *IOSR J. Comput. Eng.*, vol. 1, no. 13, pp. 56–57, 2016.
- [31] V. Subrahmanyam and K. Aruna, "Future automobile an introduction of IoT," *Int. J. Trend Res. Develop.*, vol. 2, pp. 88–90, Apr. 2017.
- [32] S. Kawthankar and C. Raut, "A survey on smart automobiles using Internet of Things for digital India," *Int. J. Recent Trends Eng. Res.*, vol. 3, no. 5, pp. 27–33, 2017.
- [33] R. K. Bajaj, M. Rao, and H. Agrawal, "Internet of Things (IoT) in the smart automotive sector: A review," in *Proc. IOSR J. Comput. Eng. (IOSR-JCE), Conf. Recent Trends Comput. Eng. (CRTCE)*, 2018, pp. 36–44.
- [34] M. U. Farooq, M. Waseem, S. Mazhar, A. Khairi, and T. Kamal, "A review on Internet of Things (IoT)," *Int. J. Comput. Appl.*, vol. 113, no. 1, pp. 1–7, 2015.
- [35] O. Helmi, M. A. Sokeh, and G. Sepidnam, "The challenges facing with the Internet of Things," *Int. J. Sci. Study*, vol. 5, no. 4, pp. 527–533, 2017.
- [36] S. I. Al-Sharekh and K. H. A. Al-Shqeerat, "Security challenges and limitations in IoT environments," *Int. J. Comput. Sci. Netw. Secur.*, vol. 19, no. 2, pp. 193–199, 2019.
- [37] S. Chen, H. Xu, D. Liu, B. Hu, and H. Wang, "A vision of IoT: Applications, challenges, and opportunities with China perspective," *IEEE Internet Things J.*, vol. 1, no. 4, pp. 349–359, Aug. 2014.
- [38] P. Matta and B. Pant, "Internet-of-Things: Genesis, challenges and applications," *J. Eng. Sci. Technol.*, vol. 14, no. 3, pp. 1717–1750, 2019.
- [39] M. Abdur, S. Habib, M. Ali, and S. Ullah, "Security issues in the Internet of Things (IoT): A comprehensive study," *Int. J. Adv. Comput. Sci. Appl.*, vol. 8, no. 6, pp. 383–388, 2017.
- [40] Mandal K and G. S. P. Ghantasala, "A complete survey on technological challenges of iot in security and privacy," *Int. J. Recent Technol. Eng.*, vol. 7, no. 6S4, pp. 332–334, 2019.
- [41] R. Roman, J. Zhou, and J. Lopez, "On the features and challenges of security and privacy in distributed Internet of Things," *Comput. Netw.*, vol. 57, no. 10, pp. 2266–2279, Jul. 2013.
- [42] S. Jabbar, F. Ullah, S. Khalid, M. Khan, and K. Han, "Semantic interoperability in heterogeneous IoT infrastructure for healthcare," *Wireless Commun. Mobile Comput.*, vol. 2017, pp. 1–10, Mar. 2017.
- [43] J. Koo, S.-R. Oh, and Y.-G. Kim, "Device identification interoperability in heterogeneous IoT platforms," *Sensors*, vol. 19, no. 6, p. 1433, Mar. 2019.
- [44] D. Dragomir, L. Gheorghe, S. Costea, and A. Radovici, "A survey on secure communication protocols for IoT systems," in *Proc. Int. Workshop Secure Internet Things (SIoT)*, 2016, pp. 47–62.
- [45] M. Elkhodr, S. Shahrestani, and H. Cheung, "Emerging wireless technologies in the Internet of Things: A comparative study," *Int. J. Wireless Mobile Netw.*, vol. 8, no. 5, pp. 67–82, Oct. 2016.
- [46] O. Khutsoane, B. Isong, and A. M. Abu-Mahfouz, "IoT devices and applications based on LoRa/LoRaWAN," in *Proc. 43rd Annu. Conf. IEEE Ind. Electron. Soc. (IECON)*, Oct. 2017, pp. 6107–6112.
- [47] S. Al-Sarawi, M. Anbar, K. Alieyan, and M. Alzubaidi, "Internet of Things (IoT) communication protocols: Review," in *Proc. 8th Int. Conf. Inf. Technol. (ICIT)*, May 2017, pp. 685–690.
- [48] D. M. Ibrahim, "Internet of Things technology based on LoRaWAN revolution," in *Proc. 10th Int. Conf. Inf. Commun. Syst. (ICICS)*, Jun. 2019, pp. 234–237.
- [49] R. S. Sinha, Y. Wei, and S.-H. Hwang, "A survey on LPWA technology: LoRa and NB-IoT," *ICT Express*, vol. 3, no. 1, pp. 14–21, Mar. 2017.
- [50] M. Luvisotto, F. Tramarin, L. Vangelista, and S. Vitturi, "On the use of LoRaWAN for indoor industrial IoT applications," *Wireless Commun. Mobile Comput.*, vol. 2018, May 2018, Art. no. 3982646.
- [51] W. Ayoub, A. E. Samhat, F. Nouvel, M. Mroue, and J.-C. Prevotet, "Internet of mobile things: Overview of LoRaWAN, DASH7, and NB-IoT in LPWANs standards and supported mobility," *IEEE Commun. Surveys Tuts.*, vol. 21, no. 2, pp. 1561–1581, 2nd Quart., 2019.
- [52] A. Adhikary, X. Lin, and Y.-P.-E. Wang, "Performance evaluation of NB-IoT coverage," in *Proc. IEEE 84th Veh. Technol. Conf. (VTC-Fall)*, Sep. 2016, pp. 1–5.
- [53] S. Madakam, R. Ramaswamy, and S. Tripathi, "Internet of Things (IoT): A literature review," *J. Comput. Commun.*, vol. 3, pp. 164–173, Jan. 2015.
- [54] B. Shabir, M. A. Khan, A. U. Rahman, A. W. Malik, and A. Wahid, "Congestion avoidance in vehicular networks: A contemporary survey," *IEEE Access*, vol. 7, pp. 173196–173215, 2019.
- [55] W. Farooq, M. A. Khan, S. Rehman, and N. A. Saqib, "A survey of multicast routing protocols for vehicular ad hoc networks," *Int. J. Distrib. Sensor Netw.*, vol. 11, no. 8, 2015, Art. no. 923086.
- [56] D. B. Tushara and P. A. H. Vardhini, "Wireless vehicle alert and collision prevention system design using atmel microcontroller," in *Proc. Int. Conf. Electr., Electron., Optim. Techn. (ICEEOT)*, Chennai, India, Mar. 2016, pp. 2784–2787.
- [57] U. Patil, P. More, R. Pandey, and U. Patkar, "Tracking and recovery of the vehicle using GPS and GSM," *Int. Res. J. Eng. Technol.*, vol. 4, no. 3, pp. 2074–2077, 2017.
- [58] B. S. Anil, K. A. Vilas, and S. R. Jagtap, "Intelligent system for vehicular accident detection and notification," in *Proc. Int. Conf. Commun. Signal Process., Melmaruvathur*, India, Apr. 2014, pp. 1238–1240.
- [59] R. K. Megalingam, R. Nammily Nair, and S. Manoj Prakhya, "Wireless vehicular accident detection and reporting system," in *Proc. Int. Conf. Mech. Electr. Technol.*, Singapore, Sep. 2010, pp. 636–640.

[60] H. N. Kumar and G. Deepak, "Accident detection and intelligent navigation system for emergency vehicles in urban areas using IoT," *Int. J. Eng. Tech.*, vol. 3, no. 6, pp. 330–334, 2017.

[61] E. Nasr, E. Kfoury, and D. Khoury, "An IoT approach to vehicle accident detection, reporting, and navigation," in *Proc. IEEE Int. Multidisciplinary Conf. Eng. Technol. (IMCET)*, Beirut, Lebanon, Nov. 2016, pp. 231–236.

[62] Z. Wen and J. Meng, "Design of vehicle positioning system based on ARM," in *Proc. Int. Conf. Bus. Manage. Electron. Inf.*, Guangzhou, China, May 2011, pp. 395–397.

[63] M. Gaber, A. M. Wahaballa, A. M. Othman, and A. Diab, "Traffic accidents prediction model using fuzzy logic: Aswan desert road case study," *J. Eng. Sci. Assiut Univ.*, vol. 45, no. 1, pp. 28–44, 2017.

[64] X. Li, D. Lord, Y. Zhang, and Y. Xie, "Predicting motor vehicle crashes using support vector machine models," *Accident Anal. Prevention*, vol. 40, no. 4, pp. 1611–1618, Jul. 2008.

[65] I. Ohe, H. Kawashima, M. Kojima, and Y. Kaneko, "A method for automatic detection of traffic incidents using neural networks," in *Proc. Pacific Rim Technol. Conf. Vehicle Navigat. Inf. Syst. Conf. 6th Int. VNIS. Ride Future*, 1995, pp. 231–235.

[66] B. Pan and H. Wu, "Urban traffic incident detection with mobile sensors based on SVM," in *Proc. 32nd Gen. Assem. Sci. Symp. Int. Union Radio Sci. (URSI GASS)*, Aug. 2017, pp. 1–4.

[67] Z. Halim, R. Kalsoom, S. Bashir, and G. Abbas, "Artificial intelligence techniques for driving safety and vehicle crash prediction," *Artif. Intell. Rev.*, vol. 46, no. 3, pp. 351–387, Oct. 2016.

[68] S. Eduku, M. O. Alhassan, and J. Sekyi-Ansah, "Design of vehicle accident prevention system using wireless technology," *Int. J. Sci. Res. Publications*, vol. 7, no. 10, pp. 397–403, 2016.

[69] S. Kasera, "IoT based accident prevention system," *Int. J. Sci. Res. Develop.*, vol. 7, no. 5, pp. 832–835, 2019.

[70] O. G. Basubeit, D. N. T. How, Y. C. Hou, and K. S. M. Sahari, "Distracted driver detection with deep convolutional neural network," *Int. J. Recent Technol. Eng.*, vol. 8, no. 4, pp. 6159–6163, 2019.

[71] K. Dwivedi, K. Biswaranjan, and A. Sethi, "Drowsy driver detection using representation learning," in *Proc. IEEE Int. Advance Comput. Conf. (IACC)*, Feb. 2014, pp. 995–999.

[72] M. Szarvas, A. Yoshizawa, M. Yamamoto, and J. Ogata, "Pedestrian detection with convolutional neural networks," in *Proc. IEEE Intell. Vehicles Symp.*, Las Vegas, NV, USA, Jun. 2005, pp. 224–229.

[73] M. Murshed and M. S. Chowdhury, "An IoT based car accident prevention and detection system with smart brake control," in *Proc. Int. Conf. Appl. Techn. Inf. Sci. (iCATIS)*, 2019, p. 23.



MUAZZAM A. KHAN KHATTAK (Senior Member, IEEE) received the Ph.D. degree in computer sciences as a Sandwich Program from IUI and UMKC, Kansas City, USA, in 2011, and the Ph.D. degree from the University of Missouri, Kansas City, in 2016. He is currently working as a Tenured Associate Professor with the Department of Computer Science, Quaid-i-Azam University, Islamabad, Pakistan. He joined the School of Electrical Engineering and Computer Science (SEECS), NUST, Islamabad, as an Assistant Professor, in 2013, where he was promoted to the Associate Dean and a Tenured Associate Professor, in 2017. He has been with the School of Computer Science, University of Ulm, Germany, and the School of Computer and the Electrical Engineering, University of Missouri, as a Research Fellow. He has worked at the Networking and Multimedia Laboratory, University of Missouri Kansas City, as a Research Fellow. His research interests include the Internet of Things, next-generation intelligent networks, block chain-based information and network security, vehicular ad-hoc/sensor actor networks, and acoustic/multimedia networks.



BALAWAL SHABIR received the bachelor's degree in electrical engineering and the master's degree in information security from Air University Islamabad. He is currently pursuing the Ph.D. degree with NUST, Pakistan. His research interests include cryptography and network security, privacy, machine learning, vehicular ad-hoc networks, the Internet of Things, big data analytics, blockchain, bioinformatics, and cloud and fog computing.



ASAD WAQAR MALIK (Senior Member, IEEE) received the Ph.D. degree with majors in parallel and distributed simulation/systems from NUST, Pakistan, in 2012. He is currently an Assistant Professor with the SEECS, NUST. He is also working as a Senior Lecturer with the Department of Information Systems, Faculty of Computer Science and Information Technology, University of Malaya, Malaysia. His primary research interests include distributed simulation, cloud/fog computing, and the Internet of Things.



SHER RAMZAN MUHAMMAD received the Ph.D. degree from TU Berlin, Germany, in 2007. In 1998, he joined International Islamic University, Islamabad (IUI), as an Assistant Professor. From 2008 to 2012, he has served as a Professor, the Chairman, and the Dean FBAS, from 2017 to 2018. He is currently a Professor with the Faculty of Computing and Information Technology (FCIT), King Abdulaziz University Jeddah, Saudi Arabia. He has authored more than 100 publications. His research interests include information security, IP multimedia subsystem, WSN, healthcare, the IoT, and NGN.



UNAIZA ALVI received the bachelor's degree in information technology from the University of the Punjab, Lahore, in 2019. She is currently pursuing the master's degree in information technology with NUST, Islamabad. Her research interests include machine learning, the Internet of Things, vehicular ad-hoc networks, and artificial intelligence.

...